

# MX•COM, INC. MiXed Signal ICs

DATA BULLETIN

## MX651

Telephone  
Subscriber Pulse Metering &  
Anti Fraud Tone Processor

PRELIMINARY INFORMATION

### Features

- Rapid 18kHz tone encoder-decoder can transfer NRZ data
  - Tx up to 166bps
  - Rx up to 62bps
- 12kHz Subscriber Pulse Metering Detector

### Applications

- Meets European 12kHz SPM Frequency Specifications
- Payphone Applications
- Card Operated Telephone Installations
- Component Adjustable Input Sensitivity
- Low Power 3.3V/5.0V Operation

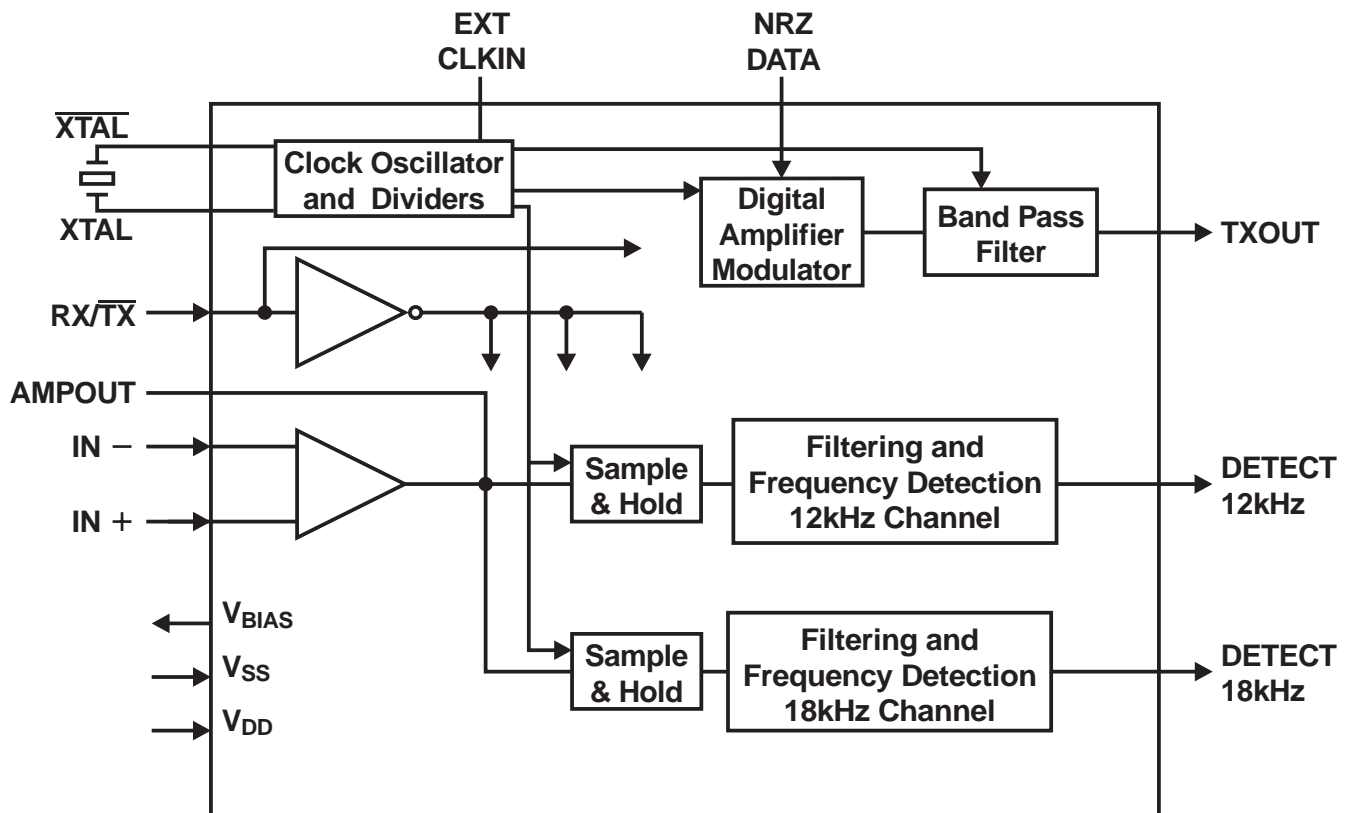

The MX651 is a low power integrated circuit which combines 12kHz Subscriber Pulse Metering (SPM) detection with 18kHz tone processing for anti-fraud purposes within a telephone system. Suitable for battery or line powered systems, the MX651 is protected from crosstalk and false decoding by employing high accuracy switched capacitor filters. By using simple logic or  $\mu$ Processor control the MX651 will:

- Decode 12kHz SPM pulses (in the presence of high level voice and 18kHz signaling) and provide a logic output.
- Transmit an NRZ amplitude modulated 18kHz security tone to line.
- Decode an incoming modulated 18kHz security tone (in the presence of high level voice and 12 kHz SPM tones) and provide a logic output.

The MX651 is available in a 16-pin SOIC (MX651DW) and a 16-pin PDIP (MX651P) package.

# CONTENTS

Section .....	Page
<b>1. Block Diagram .....</b>	<b>3</b>
<b>2. Signal List .....</b>	<b>4</b>
<b>3. External Components .....</b>	<b>5</b>
<b>4. General Description .....</b>	<b>6</b>
4.1 Overall Function .....	6
4.1.1 SPM (12kHz) Detector .....	6
4.1.2 Security Tone (18kHz) Detector (Rx Mode Only) .....	6
4.1.3 Security Tone Transmission (Tx Mode Only) .....	6
4.2 Description of Blocks (Reference Figure 1) .....	6
4.2.1 Input Amplifier .....	6
4.2.2 Sample and Hold (12kHz Channel) .....	6
4.2.3 Filtering and Frequency Detection (12kHz Channel) .....	6
4.2.4 Sample and Hold (18kHz Channel) .....	6
4.2.5 Filtering and Frequency Detection (18kHz Channel) .....	6
4.2.6 Clock Oscillator and Dividers .....	7
4.2.7 (Gate ON-OFF) (Tx Only) .....	7
4.2.8 Band Pass Filter (Tx Only) .....	7
<b>5. Application .....</b>	<b>7</b>
5.1 Device Sensitivity versus $V_{DD}$ - Input Amplifier Gain .....	7
5.2 Alias Responses - False Decodes .....	7
5.2.1 12kHz Channel .....	7
5.2.2 18kHz Channel .....	8
<b>6. Performance Specifications .....</b>	<b>8</b>
6.1 Electrical Performance .....	8
6.2 System Timing .....	11
6.2.1 Timing Diagrams .....	11
6.3 Packaging .....	12

MX•COM, Inc. reserves the right to change specifications at any time and without notice.
--

# 1. Block Diagram

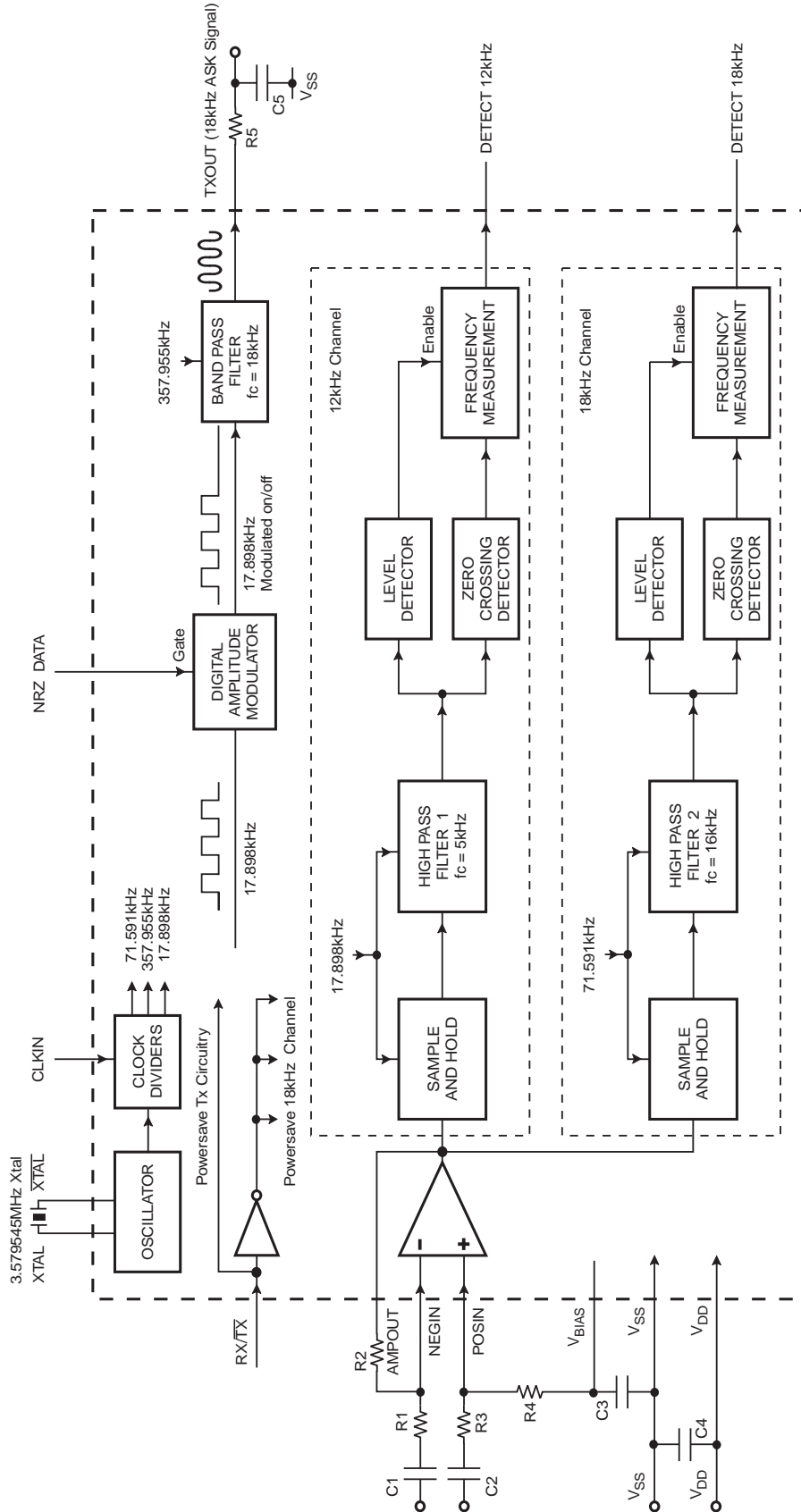
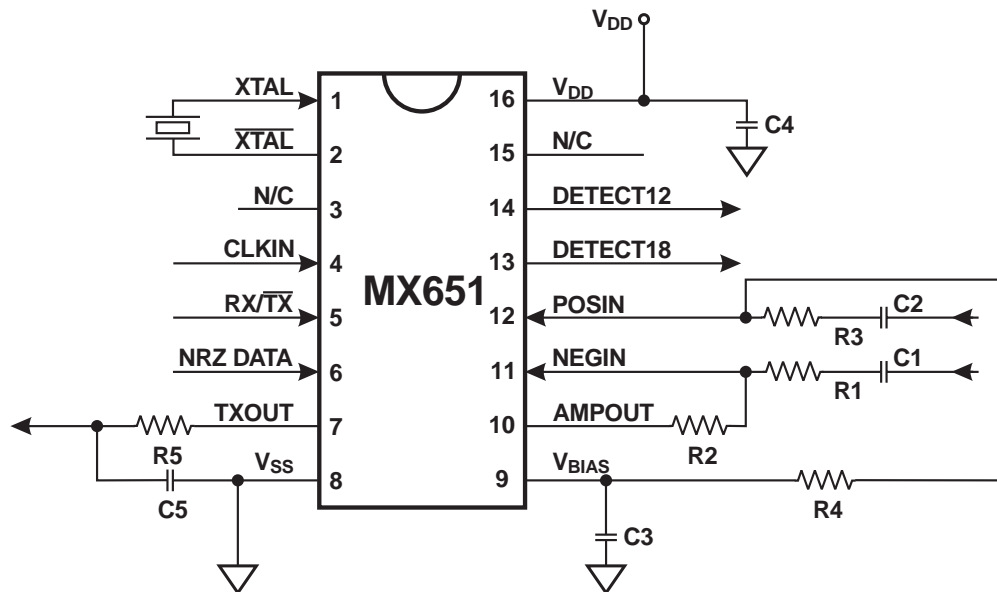

Figure 1: Block Diagram

## 2. Signal List

Pin No.	Signal	Type	Description
1	XTAL	input	Input to the on-chip oscillator inverter.
2	$\overline{\text{XTAL}}$	output	Inverted output of the on-chip oscillator.
4	CLKIN	input	A logic input which may be used when an external clock signal is available in place of a crystal. The external 3.579545MHz signal is applied to this pin and XTAL is tied to $V_{DD}$ . When not used, this pin should be tied to $V_{DD}$ .
5	RX/ $\overline{\text{TX}}$	input	A logic input which controls the operating mode of the device. In Rx, the device detects the presence of 12kHz and 18kHz tones. In Tx, the 18kHz detect function is disabled and 18kHz is transmitted from the TXOUT pin modulated ON -OFF by the NRZ Data pin.
6	NRZ DATA	input	A logic input used in Tx mode to ASK modulate the TXOUT pin. A logic high corresponds to no tone and logic low corresponds to 18kHz.
7	TXOUT	output	The Tx mode output. It is ASK modulated by the NRZ data input pin. It transmits 18kHz or no tone depending upon the state of the NRZ data input pin. This pin goes to a high impedance state when in Rx mode.
8	$V_{SS}$	power	Negative supply.
9	$V_{BIAS}$	output	A bias line for the internal circuitry, held at $V_{DD}/2$ . It also forms the analog ground for the input differential amplifier. This pin must be bypassed by a capacitor mounted close to the device pins (see Figure 1).
10	AMPOUT	output	Output of the input amplifier. External components are used in conjunction with the amplifier to couple the line signal into the device. Both inputs are available to allow a differential configuration because a two wire input is assumed.
11	NEGIN	input	Inverting input to the input amplifier.
12	POSIN	input	Non-inverting input to the input amplifier.
13	DETECT 18kHz	output	Logic output of the 18kHz channel. Logic 0 when a 18kHz tone (within specified frequency and amplitude limits) has been detected for a minimum length of time.
14	DETECT 12kHz	output	Logic output of the 12kHz channel. Logic 0 when a 12kHz tone (within specified frequency and amplitude limits) has been detected for a minimum length of time.
16	$V_{DD}$	power	Positive Supply. Levels and voltages are dependent upon this supply. This pin should be bypassed to $V_{SS}$ by a capacitor (see Figure 1).
3, 15	N/C		No internal connection: leave open circuit.

### 3. External Components



R1, R3	See Note 1	1.1M $\Omega$ @ 3.3V 1.0M $\Omega$ @ 5.0V	$\pm 1\%$ $\pm 1\%$
R2, R4	See Note 1	270k $\Omega$ @ 3.3V 330k $\Omega$ @ 5.0V	$\pm 1\%$ $\pm 1\%$
C1, C2	See Note 1	33pF @ 3.3V 68pF @ 5.0V	$\pm 10\%$ $\pm 10\%$
C3, C4		0.1 $\mu$ F	$\pm 20\%$
R5		51k $\Omega$	$\pm 1\%$
C5		100pF	$\pm 10\%$
XTAL	See Note 2	3.579545MHz	

**Figure 2: Recommended External Components**

#### External Components Notes

1. The device sensitivity is proportional to the power supply ( $V_{DD}$ ) voltage. The input gain must compensate for this and also prevent input circuitry saturation. It is recommended that amplifier components (R1 to R4, C1 and C2) be used to set the gain between -10dB (if  $V_{DD}$  is 5.0V) and -13dB (if  $V_{DD}$  is 3.3V).
2. For best results, a crystal oscillator design should drive the clock inverter input with signal levels of at least 40% of  $V_{DD}$ , peak-to-peak. Tuning fork type crystals generally cannot meet this requirement. To obtain crystal oscillator design assistance, consult your crystal manufacturer

## 4. General Description

### 4.1 Overall Function

The MX651 is a dual channel tone detector for use in European, French, and other payphone systems where 12kHz SPM and 18kHz security tones are used.

#### 4.1.1 SPM (12kHz) Detector

The SPM detector channel responds to a low level (50mV) 12kHz tone in the presence of a large security tone (16kHz - 20kHz) and speech.

The device responds after a period of continuous valid tone and so recognizes a valid SPM toneburst (minimum transmission duration, 40 - 50ms).

This function is permanently enabled.

#### 4.1.2 Security Tone (18kHz) Detector (Rx Mode Only)

This demodulates the 18kHz ASK signal in the presence of the SPM signaling.

#### 4.1.3 Security Tone Transmission (Tx Mode Only)

An 18kHz tone modulated ON - OFF by the NRZ data pin. A logic 0 gates the signal ON so that 18kHz is transmitted. A logic 1 gates the signal OFF so that no tone appears at the TXOUT pin.

## 4.2 Description of Blocks (Reference Figure 1)

### 4.2.1 Input Amplifier

This Input Amplifier is connected as a differential amplifier and is used to couple the signal into the device. It also attenuates the combined speech, SPM tone and security tone to prevent its output saturating. The signal gain should be -10dB at 5.0V supply and -13dB at 3.3V. (See Figure 2 for recommended component values).

### 4.2.2 Sample and Hold (12kHz Channel)

This samples the input signal at 17.898kHz and creates images of the incoming frequencies. The 12kHz SPM is translated to 5.898kHz and the security tone is translated to between 978Hz and 1182Hz. This simplifies the subsequent signal processing.

### 4.2.3 Filtering and Frequency Detection (12kHz Channel)

The output of the sample and hold circuit is passed to filter HPF1. This is a switched capacitor high pass filter which amplifies the frequency shifted SPM tone (about 5.9kHz) but rejects the frequency shifted security tone (about 1kHz). The filter also rejects any speech signals present. The filter output is passed to the level detect and frequency measurement circuitry which determines the presence or absence of a valid SPM signal on the line. A valid signal sends the "DETECT 12kHz" pin to logic low.

### 4.2.4 Sample and Hold (18kHz Channel)

This samples the input signal at 71.592kHz. It is synchronized with the following high pass filter, which is a switched capacitor circuit with the same sampling rate. The sample and hold circuit stores the value of the input waveform value between sampling instants so that it is a suitable input for the filter.

Without the sample and hold circuit, speech or SPM tone components which are large compared with the security tone would interfere with the level discrimination at the filter output.

### 4.2.5 Filtering and Frequency Detection (18kHz Channel)

The output of the sample and hold circuit is passed to filter HPF2. This is a switched capacitor high pass filter which amplifies the security tone (about 16.92kHz - 19.08kHz) but rejects the SPM tone.

The filter output signal is passed to the level detect and frequency measurement circuitry which determines the presence or absence of a valid security tone on the line. A valid signal sends the "DETECT 18kHz" pin to logic 0.

#### 4.2.6 Clock Oscillator and Dividers

These circuits generate the internal clocks by division of the oscillator reference frequency. The crystal is connected as shown in Figure 2 without any need for other external components. When a crystal is used, the CLKIN pin should be left open circuit.

Alternatively, when a frequency of 3.579545MHz is externally available, the use of a crystal is unnecessary. The external frequency is applied to the CLKIN pin. In this case, the XTAL pin should be tied to  $V_{DD}$ .

In Tx, the dividers also generate a pulse train, frequency 18kHz, which is passed to the Tx circuitry (Gate ON - OFF and Band Pass Filter) for digital modulation and filtering.

#### 4.2.7 (Gate ON-OFF) (Tx Only)

This circuit is a digital block. It performs ON - OFF modulation of the 18kHz pulse train generated from the crystal frequency by the digital dividers. It is controlled by the NRZ DATA pin and is used to encode NRZ data packets as pulsed 18kHz (ASK data). The modulated digital signal is passed to the Tx filter for wave shaping.

#### 4.2.8 Band Pass Filter (Tx Only)

This is a 4th order band pass filter with center frequency 18kHz. It shapes the modulated digital pulse train from the previous block into a low distortion pulsed sinusoidal waveform. The resulting signal is the system acknowledgment security tone. It is transmitted by the subscriber equipment, via the telephone link, to the local exchange.

## 5. Application

### 5.1 Device Sensitivity versus $V_{DD}$ - Input Amplifier Gain

The device sensitivity is proportional to  $V_{DD}$  because internal voltage references are derived from the power supply. Accordingly, input amplifier signal gain should be adjusted via external components. Figure 2 shows components recommended for 5.0V and 3.3V operation.

### 5.2 Alias Responses - False Decodes

The MX651 is designed to work in telephone systems where certain ranges of input frequencies are expected and other ranges are not. The 12kHz SPM channel works in the presence of speech and a tone in the range 16kHz - 20kHz. The security tone detector functions in the presence of an interfering tone in the range 11kHz - 13kHz. A significant tone at other frequencies may interfere with correct decoding of valid transmissions and should be avoided.

A small range of input frequencies could cause false decoding when no valid tone has been received. This is because of the frequency shifting property of the SPM channel and the sampled data filters in both channels.

The tone detectors in both the 12kHz and 18kHz channels will respond to 'other than normal' tones. Accordingly, such tones should be avoided.

#### 5.2.1 12kHz Channel

The 12kHz tone detector response frequencies are described by the following two equations:

$$f_{12\text{kHz plus}} = [(n \times 17.898\text{kHz}) + 5.893\text{kHz}] \pm 0.185\text{kHz}$$

$$f_{12\text{kHz minus}} = [(n \times 17.898\text{kHz}) - 5.893\text{kHz}] \pm 0.185\text{kHz}$$

n	nominal plus detect frequency (kHz)	nominal minus detect frequency (kHz)
0	5.893	N/A
1	23.791	12.005
2	41.689	29.903
...	...	...

**Note:** A valid SPM input, in the range 11.82kHz - 12.18kHz, is met when;  $n = 1$  and the nominal minus sign (-) detect frequency is calculated. The other inputs represent false decodes. The response time and level sensitivity for a false decode is the same as that for a valid decode, e.g. 42ms - 45ms of 5708Hz at 50mV could cause a false decode at the "DETECT 12kHz" pin.

### 5.2.2 18kHz Channel

The 18kHz tone detector response frequencies are described by the following two equations:

$$f_{18\text{kHz plus}} = [(n \times 71.591\text{kHz}) + 18.0\text{kHz}] \pm 1.08\text{kHz}$$

$$f_{18\text{kHz minus}} = [(n \times 71.591\text{kHz}) - 18.0\text{kHz}] \pm 1.08\text{kHz}$$

↙ sign

n	nominal plus detect frequency (kHz)	nominal minus detect frequency (kHz)
0	18	N/A
1	89.591	53.591
2	161.182	125.182
3	232.773	196.773
...	...	...

Note: A valid security tone input is met when,  $n = 0$  and the nominal plus sign (+) detect frequency is calculated. The other inputs represent false decodes. The response time and level sensitivity for a false decode is the same as that for a valid decode, e.g. 5.8ms of 52.511kHz at 40mV could cause a false response at "DETECT18kHz" pin.

## 6. Performance Specifications

### 6.1 Electrical Performance

#### Absolute Maximum Ratings

Exceeding these maximum ratings can result in damage to the device. Correct operation of the device outside these limits is not implied.

General	Min.	Max.	Units
Supply ( $V_{DD} - V_{SS}$ )	-0.3	7.0	V
Voltage on any pin (wrt $V_{SS}$ )	-0.3	$V_{DD} + 0.3$	V
Current			
$V_{DD}$	-30	30	mA
$V_{SS}$	-30	30	mA
Any other pins	-20	20	mA
<b>DW / P Packages</b>			
Total Allowable Power Dissipation at $T_{AMB} = 25^{\circ}\text{C}$		800	mW
Derating above $25^{\circ}\text{C}$		13	mW/ $^{\circ}\text{C}$ above $25^{\circ}\text{C}$
Operating Temperature	-40	85	$^{\circ}\text{C}$
Storage Temperature	-55	125	$^{\circ}\text{C}$



## Operating Limits

For the following conditions unless otherwise specified.

	Min.	Max.	Units
Supply ( $V_{DD} - V_{SS}$ )	3.0	5.5	V
Operating Temperature	-40	85	°C
Xtal Frequency	3.579008	3.580082	MHz

## Operating Characteristics

For the following conditions unless otherwise specified:

Xtal Frequency = 3.579545MHz, Noise and Distortion Measured in 50kHz Bandwidth

$V_{DD} = 3.3V$  to  $5.5V$  @  $T_{AMB} = 25^{\circ}C$ .

	Notes	Min.	Typ.	Max.	Units
<b>DC Parameters</b>					
$I_{DD}$	1		2.5	4.0	mA
$I_{DD}$	2		1.0	2.0	mA
Logic 1 Input Level	1, 3	3.5			V
Logic 0 Input Level	1, 3			1.5	V
Logic 1 Output Level at $I_{OH} = -120\mu A$	1	4.6			V
Logic 1 Output Level at $I_{OL} = 360\mu A$	1			0.4	V
<b>AC Parameters</b>					
<b>Tx Output</b>					
Tx Output Impedance (Tx mode)	4		1.0	2.5	k $\Omega$
Tx Output Impedance (Rx mode)	4	300	500		k $\Omega$
Output Frequency		17.82		18.18	kHz
Output Distortion	5			2	%
Signal Level	5, 6	3.0	3.4	3.7	V <sub>P-P</sub>
Signal Level	5, 7	2.0	2.2	2.4	V <sub>P-P</sub>
Response/De-response Times	8			100	$\mu s$
Rise/Fall Times	9			5	ms
<b>Rx Input</b>					
Rx Input Impedance		10.0			M $\Omega$
Rx Input Amp Voltage Gain			500		V/V
<b>12kHz (SPM) Channel Performance</b>					
<b>With Interfering Speech &amp; Security Tone</b>					
Input Signal Level	12			800	mV
Decode Min Signal Level	12			50	mV
No Decode Max Signal Level	12	25			mV
Response Delay	12, 13	40		50	ms
De-response Delay	12, 13	40		50	ms
Detect Bandwidth	12	11.82		12.18	kHz
Not Detect Frequencies (below 12kHz)	12			11.52	kHz
Not Detect Frequencies (above 12kHz)	12	12.48			kHz

	Notes	Min.	Typ.	Max.	Units
<b>18kHz (Security Tone) Channel Performance</b>	14				
<b>With Interfering Speech &amp; SPM Tone</b>	15				
Input Signal Level	15			1.2	V
Decode Min Signal Level	15			40	mV
No Decode Max Signal Level	15	10			mV
Response/De-response Times	15, 16			8	ms
Detect Bandwidth	15	16.92		19.08	kHz
Not Detect Frequencies (below 18kHz)	15			16.25	kHz
Not Detect Frequencies (above 18kHz)	15	19.75			kHz

### Operating Characteristics Notes:

- At  $V_{DD} = 5.0V$  only,  $I_{DD}$  specification does not include any current drawn from the device pins by external circuitry.
- At  $V_{DD} = 3.3V$  only,  $I_{DD}$  specification does not include any current drawn from the device pins by external circuitry.
- CLKIN input signal may be sinusoidal.
- Small signal impedance.
- At output of smoothing network.
- $V_{DD} = 5.0V$ .
- $V_{DD} = 3.3V$ .
- The time between a logic 1 - 0 transition at NRZ data input and the tone amplitude at TXOUT reaching 10% of its full value or between a 0 - 1 transition at NRZ data input and the tone amplitude falling to 90% of its full value.
- The time for the 18kHz tone amplitude at TXOUT to rise from 10% to 90% or to fall from 90% to 10% of its full value.
- Input amplifier signal gain set to -10dB for  $V_{DD} = 5.0V$ , -13dB for  $V_{DD} = 3.3V$ .
- Maximum 10% distortion for incoming SPM tone, not including interfering speech or security tone (16kHz - 20kHz). Minimum SNR 22dB for incoming SPM tone before the input capacitor.
- Signal levels at the amplifier input, i.e. before the input capacitor. 12kHz channel performance specified in the presence of the following interfering signals:
  - A 1.2V continuous tone in the frequency range 16kHz - 20kHz
  - An ordinary speech signal containing frequencies in the range 300Hz - 3400Hz of maximum instantaneous amplitude  $8.0V_{P-P}$
- The device responds after 40-50ms of continuous valid tone and de-responds after: a 40-50ms period of no-tone, tones less than 25mV or an out of band tone.
- Maximum 10% distortion for incoming security tone, not including interfering SPM tone (11kHz - 13kHz). Minimum 20dB SNR for incoming security tone.
- Signal level specified at the amplifier input, i.e. before the input capacitor. Performance specified in the presence of an interfering 800mV continuous tone in the frequency range 11kHz - 13kHz.
- The device responds after 8ms of continuous valid tone and de-responds after any of: an 8ms period of no-tone, tone of 10mV or less, or an out of band tone.

## 6.2 System Timing

		Notes	Min	Max	Unit
<b>Rx</b>					
12KHz	Response Delay		40	50	ms
	De-response Delay		40	50	ms
18KHz	Response Time			8	ms
	De-response Time			8	ms
<b>Tx</b>					
	Transmit 0 Time	Note 1, 2		5.1	ms
	Transmit 1 Time	Note 1, 2		5.1	ms

### Note:

1. Tx Transmit Times include both Response/De-response Times and Rise/Fall Times.
2. The Tx Transmit 0 and Transmit 1 Time must exceed 5.1ms.

### 6.2.1 Timing Diagrams

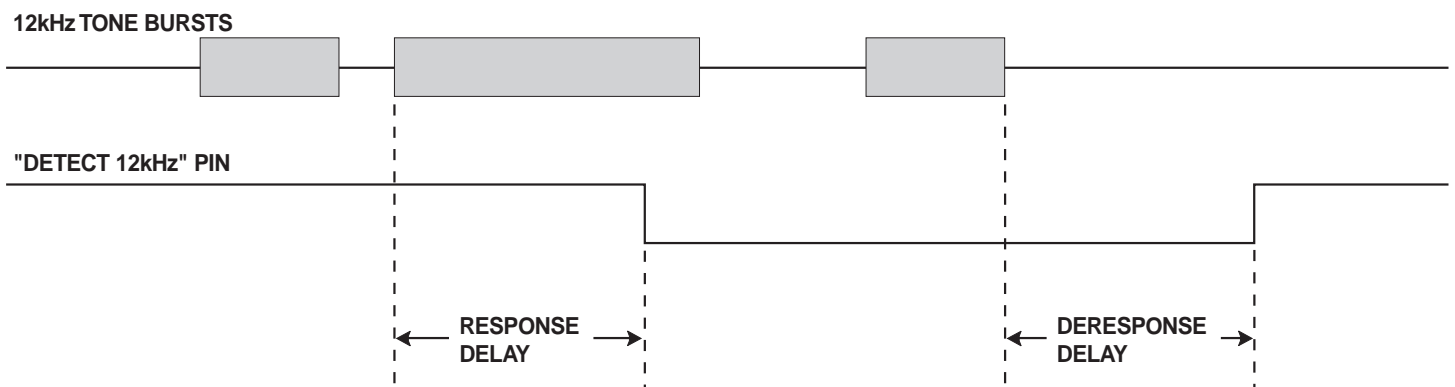

Figure 3: SPM (12kHz) channel. Toneburst and tonegaps < the response and de-response delays are ignored

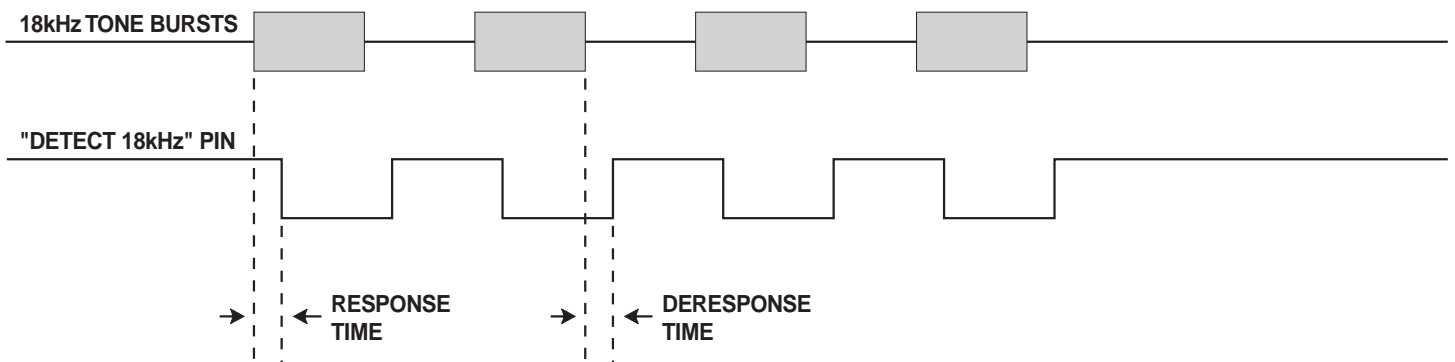

Figure 4: Security tone (18kHz) channel. The response and de-response times are short to enable the device to recognize short ON-OFF bursts (20ms each)

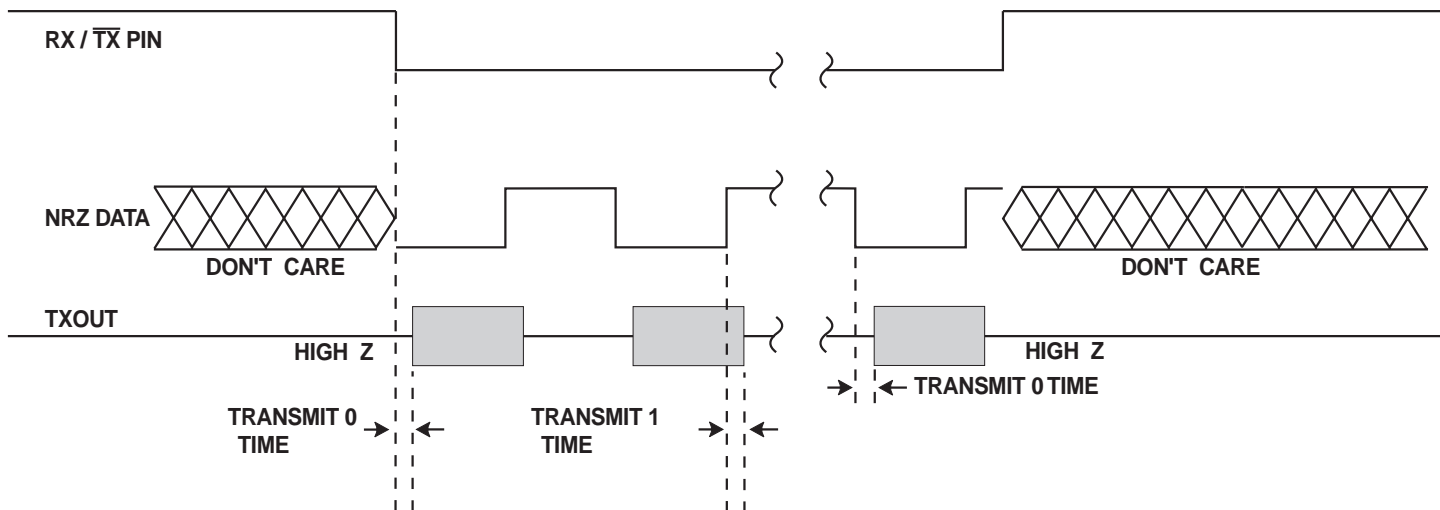

Figure 5: Transmit Mode. TXOUT is modulated by the NRZ DATA pin. An 18kHz toneburst represents logic 0 and "no tone" represents logic 1. Data packets with symbol periods  $\geq 6$ ms can be transmitted.

### 6.3 Packaging

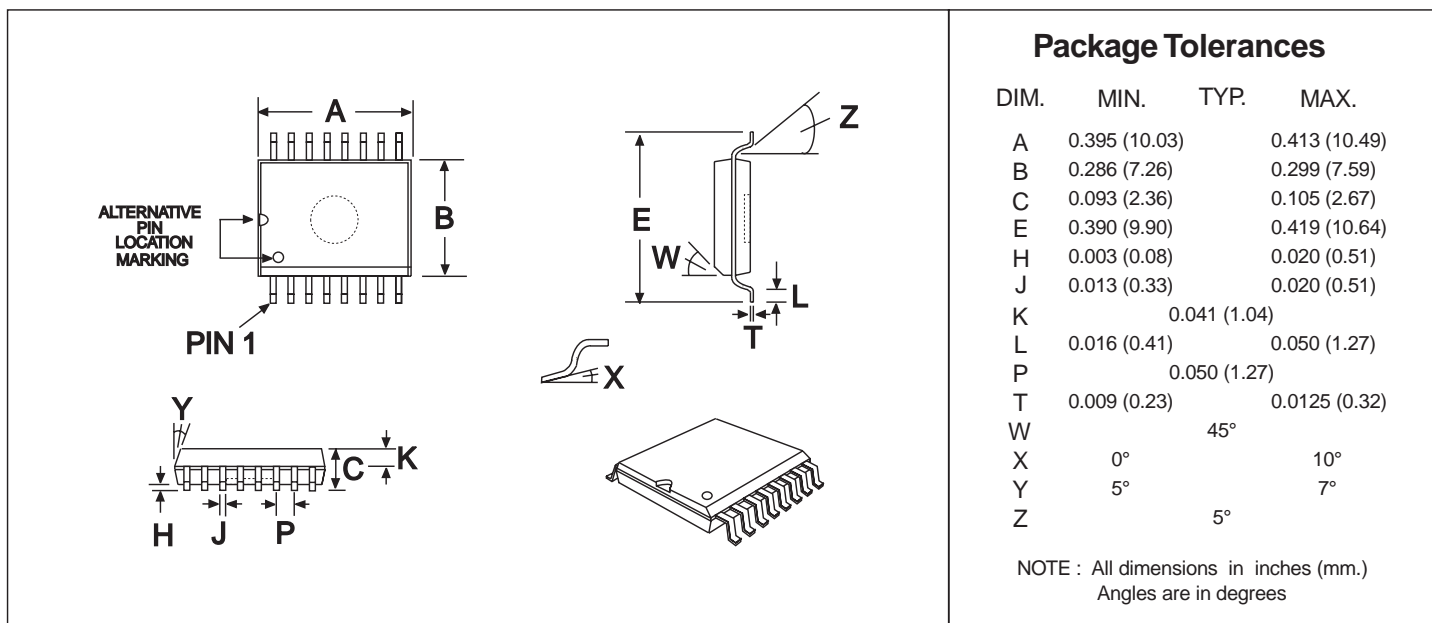

Figure 6: SOIC Mechanical Outline: Order as part no. MX651DW

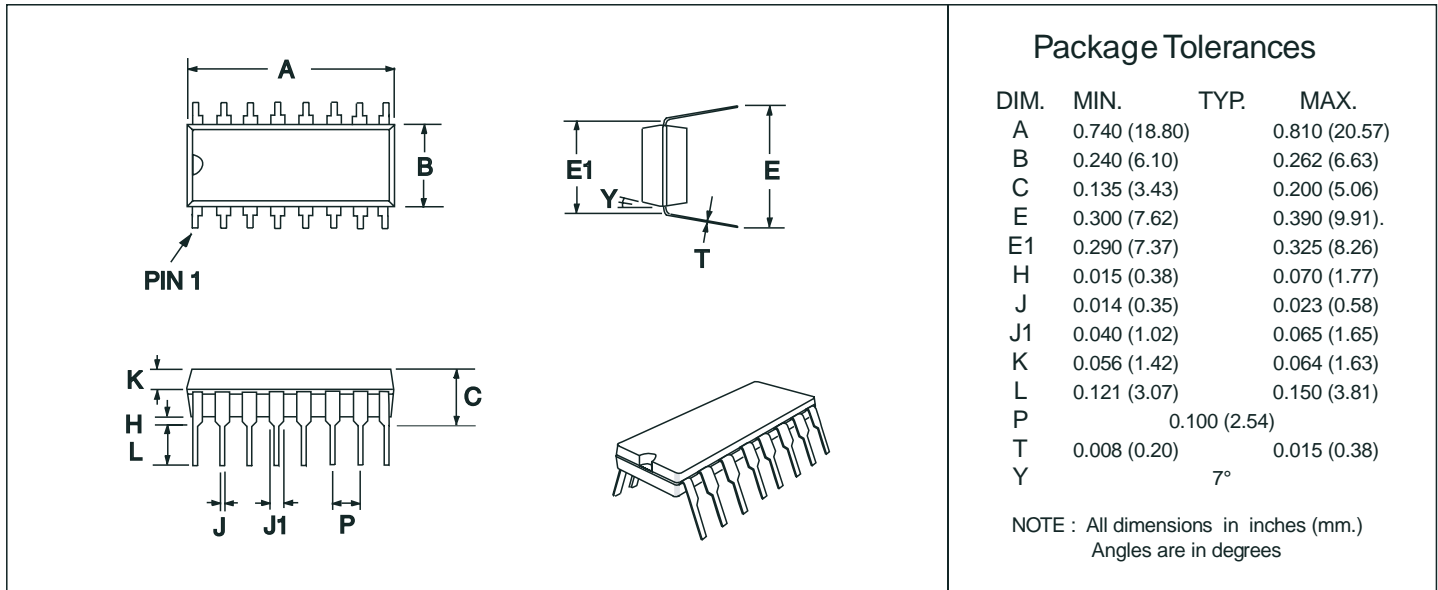

Figure 7: PDIP Mechanical Outline: *Order as part no. MX651P*