

# S29CD-G Flash Family

## S29CD032G, S29CD016G

32 Megabit (1M x 32-Bit), 16 Megabit (512K x 32-Bit)

2.5 Volt-only Burst Mode, Dual Boot, Simultaneous Read/  
Write Flash Memory with VersatileI/O™ featuring 170 nm  
Process Technology



*Data Sheet*

**PRELIMINARY**

**Notice to Readers:** This document states the current technical specifications regarding the Spansion product(s) described herein. The Preliminary status of this document indicates that product qualification has been completed, and that initial production has begun. Due to the phases of the manufacturing process that require maintaining efficiency and quality, this document may be revised by subsequent versions or modifications due to changes in technical specifications.

**Note:** This document supercedes datasheet information for the S29CD016G revision A4, and S29CD032G revision B0. The S29CD-G device is the factory-recommended migration path. Please refer to specifications and ordering information found in this document.

## Notice On Data Sheet Designations

SpanSion LLC issues data sheets with Advance Information or Preliminary designations to advise readers of product information or intended specifications throughout the product life cycle, including development, qualification, initial production, and full production. In all cases, however, readers are encouraged to verify that they have the latest information before finalizing their design. The following descriptions of SpanSion data sheet designations are presented here to highlight their presence and definitions.

### Advance Information

The Advance Information designation indicates that SpanSion LLC is developing one or more specific products, but has not committed any design to production. Information presented in a document with this designation is likely to change, and in some cases, development on the product may discontinue. SpanSion LLC therefore places the following conditions upon Advance Information content:

"This document contains information on one or more products under development at SpanSion LLC. The information is intended to help you evaluate this product. Do not design in this product without contacting the factory. SpanSion LLC reserves the right to change or discontinue work on this proposed product without notice."

### Preliminary

The Preliminary designation indicates that the product development has progressed such that a commitment to production has taken place. This designation covers several aspects of the product life cycle, including product qualification, initial production, and the subsequent phases in the manufacturing process that occur before full production is achieved. Changes to the technical specifications presented in a Preliminary document should be expected while keeping these aspects of production under consideration. SpanSion places the following conditions upon Preliminary content:

"This document states the current technical specifications regarding the SpanSion product(s) described herein. The Preliminary status of this document indicates that product qualification has been completed, and that initial production has begun. Due to the phases of the manufacturing process that require maintaining efficiency and quality, this document may be revised by subsequent versions or modifications due to changes in technical specifications."

### Combination

Some data sheets will contain a combination of products with different designations (Advance Information, Preliminary, or Full Production). This type of document will distinguish these products and their designations wherever necessary, typically on the first page, the ordering information page, and pages with DC Characteristics table and AC Erase and Program table (in the table notes). The disclaimer on the first page refers the reader to the notice on this page.

### Full Production (No Designation on Document)

When a product has been in production for a period of time such that no changes or only nominal changes are expected, the Preliminary designation is removed from the data sheet. Nominal changes may include those affecting the number of ordering part numbers available, such as the addition or deletion of a speed option, temperature range, package type, or  $V_{IO}$  range. Changes may also include those needed to clarify a description or to correct a typographical error or incorrect specification. SpanSion LLC applies the following conditions to documents in this category:

"This document states the current technical specifications regarding the SpanSion product(s) described herein. SpanSion LLC deems the products to have been in sufficient production volume such that subsequent versions of this document are not expected to change. However, typographical or specification corrections, or modifications to the valid combinations offered may occur."

Questions regarding these document designations may be directed to your local AMD or Fujitsu sales office.

# S29CD-G Flash Family

## S29CD032G, S29CD016G

32 Megabit (1M x 32-Bit), 16 Megabit (512K x 32-Bit)  
2.5 Volt-only Burst Mode, Dual Boot, Simultaneous Read/  
Write Flash Memory with VersatileI/O™ featuring 170 nm  
Process Technology



Data Sheet

PRELIMINARY

## Distinctive Characteristics

### Architecture Advantages

- **Simultaneous Read/Write operations**
  - Read data from one bank while executing erase/program functions in other bank
  - Zero latency between read and write operations
  - Two bank architecture: large bank/small bank 75%/25%
- **User-Defined x32 Data Bus**
- **Dual Boot Block**
  - Top and bottom boot sectors in the same device
- **Flexible sector architecture**
  - CD032G: Eight 2K Double Word, Sixty-two 16K Double Word, and Eight 2K Double Word sectors
  - CD016G: Eight 2K Double Word, Thirty-two 16K Double Word, and Eight 2K Double Word sectors
- **Secured Silicon Sector (256 Bytes)**
  - *Factory locked and identifiable*: 16 bytes for secure, random factory Electronic Serial Number; Also known as Electronic Marking
- **Manufactured on 170 nm Process Technology**
- **Programmable Burst interface**
  - Interfaces to any high performance processor
  - Linear Burst Read Operation: 2, 4, and 8 double word linear burst with or without wrap around
- **Program Operation**
  - Performs synchronous and asynchronous write operations of burst configuration register settings independently
- **Single power supply operation**
  - Optimized for 2.5 to 2.75 volt read, erase, and program operations
- **Compatibility with JEDEC standards (JC42.4)**
  - Software compatible with single-power supply Flash
  - Backward-compatible with AMD/Fujitsu Am29LV/MBM29LV and Am29F/MBM29F flash memories

### Performance Characteristics

- **High performance read access**
  - Initial/random access times of 48 ns (32 Mb) and 54 ns (16 Mb)
  - Burst access times of 7.5 ns (32 Mb) or 9 ns (16Mb)
- **Ultra low power consumption**
  - Burst Mode Read: 90 mA @ 75 MHz max
  - Program/Erase: 50 mA max

- Standby mode: CMOS: 60  $\mu$ A max
- **1 million write cycles per sector typical**
- **20 year data retention typical**
- **VersatileI/O™ control**
  - Generates data output voltages and tolerates data input voltages as determined by the voltage on the V<sub>IO</sub> pin
  - 1.65 V to 3.60 V compatible I/O signals

### Software Features

- **Persistent Sector Protection**
  - Locks combinations of individual sectors and sector groups to prevent program or erase operations within that sector (requires only V<sub>CC</sub> levels)
- **Password Sector Protection**
  - Locks combinations of individual sectors and sector groups to prevent program or erase operations within that sector using a user-definable 64-bit password
- **Supports Common Flash Interface (CFI)**
- **Unlock Bypass Program Command**
  - Reduces overall programming time when issuing multiple program command sequences
- **Data# Polling and toggle bits**
  - Provides a software method of detecting program or erase operation completion

### Hardware Features

- **Program Suspend/Resume & Erase Suspend/Resume**
  - Suspends program or erase operations to allow reading, programming, or erasing in same bank
- **Hardware Reset (RESET#), Ready/Busy# (RY/BY#), and Write Protect (WP#) inputs**
- **ACC input**
  - Accelerates programming time for higher throughput during system production
- **Package options**
  - 80-pin PQFP
  - 80-ball Fortified BGA
  - Pb-free package option also available
  - Known Good Die

## General Description

The S29CD-G Flash Family is a burst mode, Dual Boot, Simultaneous Read/Write family of Flash Memory with VersatileI/O™ manufactured on 170 nm Process Technology.

The S29CD032G is a 32 Megabit, 2.6 Volt-only (2.50 V - 2.75 V) single power supply burst mode flash memory device that can be configured for 1,048,576 double words.

The S29CD016G is a 16 Megabit, 2.6 Volt-only (2.50 V - 2.75 V) single power supply burst mode flash memory device that can be configured for 524,288 double words.

To eliminate bus contention, each device has separate chip enable (CE#), write enable (WE#) and output enable (OE#) controls. Additional control inputs are required for synchronous burst operations: Load Burst Address Valid (ADV#), and Clock (CLK).

Each device requires only a single 2.6 Volt-only (2.50 V – 2.75 V) for both read and write functions. A 12.0-volt  $V_{PP}$  is not required for program or erase operations, although an acceleration pin is available if faster programming performance is required.

The device is entirely command set compatible with the JEDEC single-power-supply Flash standard. The software command set is compatible with the command sets of the 5 V Am29F or MBM29F and 3 V Am29LV or MBM29LV Flash families. Commands are written to the command register using standard microprocessor write timing. Register contents serve as inputs to an internal state-machine that controls the erase and programming circuitry. Write cycles also internally latch addresses and data needed for the programming and erase operations. Reading data out of the device is similar to reading from other Flash or EPROM devices.

The **Unlock Bypass** mode facilitates faster programming times by requiring only two write cycles to program data instead of four.

The **Simultaneous Read/Write architecture** provides simultaneous operation by dividing the memory space into two banks. The device can begin programming or erasing in one bank, and then simultaneously read from the other bank, with zero latency. This releases the system from waiting for the completion of program or erase operations. See [Simultaneous Read/Write Operations Overview](#).

The device provides a 256-byte **Secured Silicon Sector** that contains Electronic Marking Information for easy device traceability.

In addition, the device features several levels of sector protection, which can disable both the program and erase operations in certain sectors or sector groups: **Persistent Sector Protection** is a command sector protection method that replaces the old 12 V controlled protection method; **Password Sector Protection** is a highly sophisticated protection method that requires a password before changes to certain sectors or sector groups are permitted; **WP# Hardware Protection** prevents program or erase in the two outermost 8 Kbytes sectors of the larger bank.

The device defaults to the Persistent Sector Protection mode. The customer must then choose if the Standard or Password Protection method is most desirable. The WP# Hardware Protection feature is always available, independent of the other protection method chosen.

The **VersatileI/O™ (V<sub>CCQ</sub>)** feature allows the output voltage generated on the device to be determined based on the  $V_{IO}$  level. This feature allows this device to operate in the 1.8 V I/O environment, driving and receiving signals to and from other 1.8 V devices on the same bus.

The host system can detect whether a program or erase operation is complete by observing the RY/BY# pin, by reading the DQ7 (Data# Polling), or DQ6 (toggle) **status bits**. After a program or erase cycle is completed, the device is ready to read array data or accept another command.

The **sector erase architecture** allows memory sectors to be erased and reprogrammed without affecting the data contents of other sectors. The device is fully erased when shipped from the factory.

**Hardware data protection** measures include a low  $V_{CC}$  detector that automatically inhibits write operations during power transitions. The **password and software sector protection** feature disables both program and erase operations in any combination of sectors of memory. This can be achieved in-system at  $V_{CC}$  level.

The **Program/Erase Suspend/Erase Resume** feature enables the user to put erase on hold for any period of time to read data from, or program data to, any sector that is not selected for erasure. True background erase can thus be achieved.

The **hardware RESET# pin** terminates any operation in progress and resets the internal state machine to reading array data.

The device offers two power-saving features. When addresses are stable for a specified amount of time, the device enters the **automatic sleep mode**. The system can also place the device into the **standby mode**. Power consumption is greatly reduced in both these modes.

AMD's Flash technology combines years of Flash memory manufacturing experience to produce the highest levels of quality, reliability and cost effectiveness. The device electrically erases all bits within a sector simultaneously via Fowler-Nordheim tunnelling. The data is programmed using hot electron injection.

## Table of Contents

<b>Product Selector Guide</b> .....	<b>9</b>
<b>Block Diagram</b> .....	<b>11</b>
<b>Block Diagram of Simultaneous Read/Write Circuit</b> .....	<b>12</b>
<b>Connection Diagrams</b> .....	<b>13</b>
<b>Physical Dimensions</b> .....	<b>14</b>
PRQ080–80-Lead Plastic Quad Flat Package .....	14
Special Package Handling Instructions .....	15
LAA080–80-ball Fortified Ball Grid Array (13 x 11 mm) .....	16
<b>Pin Configuration</b> .....	<b>17</b>
<b>Logic Symbols</b> .....	<b>18</b>
S29CD032G .....	18
S29CD016G .....	18
<b>Memory Map and Sector Protect Groups</b> .....	<b>19</b>
<b>Device Operations</b> .....	<b>23</b>
Versatile/O™ (V <sub>IO</sub> ) Control .....	23
Requirements for Reading Array Data .....	23
Simultaneous Read/Write Operations Overview .....	24
Overview .....	24
Program/Erase Suspend and Simultaneous Operation .....	24
Common Flash Interface (CFI) and Password Program/Verify and Simultaneous Operation .....	24
Writing Commands/Command Sequences .....	24
Accelerated Program and Erase Operations .....	25
Autoselect Functions .....	25
Automatic Sleep Mode (ASM) .....	25
Standby Mode .....	25
RESET#: Hardware Reset Pin .....	26
Output Disable Mode .....	26
Autoselect Mode .....	26
Asynchronous Read Operation (Non-Burst) .....	27
Synchronous (Burst) Read Operation .....	27
Linear Burst Read Operations .....	28
CE# Control in Linear Mode .....	28
ADV# Control In Linear Mode .....	28
RESET# Control in Linear Mode .....	29
OE# Control in Linear Mode .....	29
IND/WAIT# Operation in Linear Mode .....	29
Burst Access Timing Control .....	30
Initial Burst Access Delay Control .....	30
Burst CLK Edge Data Delivery .....	30
Burst Data Hold Control .....	30
Asserting RESET# During A Burst Access .....	31
Configuration Register .....	31
Initial Access Delay Configuration .....	33
<b>Sector Protection</b> .....	<b>33</b>
Sector and Sector Groups .....	33
Persistent Sector Protection .....	33
Password Sector Protection .....	33
WP# Hardware Protection .....	33
Persistent Sector Protection .....	34
Persistent Protection Bit (PPB) .....	34
Persistent Protection Bit Lock (PPB Lock) .....	34
Dynamic Protection Bit (DYB) .....	34
Persistent Sector Protection Mode Locking Bit .....	35

Password Protection Mode .....	36
Password and Password Mode Locking Bit .....	36
64-bit Password .....	36
Write Protect (WP#) .....	37
Secured Silicon OTP Sector and Simultaneous Operation .....	37
Persistent Protection Bit Lock .....	37
Hardware Data Protection .....	37
Low $V_{CC}$ Write Inhibit .....	37
Write Pulse <i>Glitch</i> Protection .....	38
Logical Inhibit .....	38
Power-Up Write Inhibit .....	38
$V_{CC}$ and $V_{IO}$ Power-up And Power-down Sequencing .....	38
<b>Command Definitions .....</b>	<b>42</b>
Reading Array Data in Non-burst Mode .....	42
Reading Array Data in Burst Mode .....	42
Read/Reset Command .....	43
Autoselect Command .....	43
Program Command Sequence .....	43
Accelerated Program Command .....	44
Unlock Bypass Command Sequence .....	44
Unlock Bypass Entry Command .....	45
Unlock Bypass Program Command .....	45
Unlock Bypass Chip Erase Command .....	46
Unlock Bypass CFI Command .....	46
Unlock Bypass Reset Command .....	46
Chip Erase Command .....	46
Sector Erase Command .....	46
Sector Erase and Program Suspend Command .....	47
Sector Erase and Program Suspend Operation Mechanics .....	47
Sector Erase and Program Resume Command .....	49
Configuration Register Read Command .....	49
Configuration Register Write Command .....	49
Common Flash Interface (CFI) Command .....	50
Password Program Command .....	50
Password Verify Command .....	50
Password Protection Mode Locking Bit Program Command .....	51
Persistent Sector Protection Mode Locking Bit Program Command .....	51
PPB Lock Bit Set Command .....	51
DYB Write Command .....	51
Password Unlock Command .....	51
PPB Program Command .....	52
All PPB Erase Command .....	52
DYB Write .....	52
PPB Lock Bit Set .....	53
DYB Status .....	53
PPB Status .....	53
PPB Lock Bit Status .....	53
Non-volatile Protection Bit Program And Erase Flow .....	53
<b>Write Operation Status .....</b>	<b>56</b>
DQ7: Data# Polling .....	56
RY/BY#: Ready/Busy# .....	56
DQ6: Toggle Bit I .....	58
DQ2: Toggle Bit II .....	58
Reading Toggle Bits DQ6/DQ2 .....	59
DQ5: Exceeded Timing Limits .....	60

DQ3: Sector Erase Timer .....	61
<b>Absolute Maximum Ratings</b> .....	<b>62</b>
<b>Operating Ranges</b> .....	<b>63</b>
Industrial (I) Devices .....	63
Extended (E) Devices .....	63
V <sub>CC</sub> Supply Voltages .....	63
V <sub>IO</sub> Supply Voltages .....	63
<b>DC Characteristics</b> .....	<b>64</b>
CMOS Compatible .....	64
Zero Power Flash .....	65
<b>Test Conditions</b> .....	<b>66</b>
<b>Test Specifications</b> .....	<b>66</b>
<b>Key to Switching Waveforms</b> .....	<b>66</b>
<b>Switching Waveforms</b> .....	<b>66</b>
<b>AC Characteristics</b> .....	<b>67</b>
V <sub>CC</sub> and V <sub>IO</sub> Power-up .....	67
Asynchronous Read Operations .....	68
Burst Mode Read for 32 Mb & 16 Mb .....	69
Hardware Reset (RESET#) .....	71
Erase/Program Operations .....	73
Alternate CE# Controlled Erase/Program Operations .....	77
<b>Erase and Programming Performance</b> .....	<b>79</b>
<b>Latchup Characteristics</b> .....	<b>79</b>
<b>PQFP and Fortified BGA Pin Capacitance</b> .....	<b>79</b>
<b>Revision Summary</b> .....	<b>80</b>



## Tables

Table 1.	32 Mb Memory Map and Sector Protect Groups for Ordering Option 00, Top Boot . . . . .	19
Table 2.	32 Mb Memory Map and Sector Protect Groups for Ordering Option 01, Bottom Boot . . . . .	20
Table 3.	16 Mb, Memory Map and Sector Protect Groups for Ordering Option 00, Top Boot . . . . .	21
Table 4.	16 Mb, Memory Map and Sector Protect Groups for Ordering Option 00, Bottom Boot . . . . .	22
Table 5.	Device Bus Operation. . . . .	23
Table 6.	Allowable Conditions for Simultaneous Operation . . . . .	24
Table 7.	S29CD-G Flash Family Autoselect Codes (High Voltage Method) . . . . .	27
Table 8.	32- Bit Linear and Burst Data Order. . . . .	28
Table 9.	Valid Configuration Register Bit Definition for IND/WAIT#. . . . .	29
Table 10.	Burst Initial Access Delay . . . . .	30
Table 11.	Configuration Register Definitions . . . . .	32
Table 12.	Configuration Register After Device Reset . . . . .	33
Table 13.	Sector Protection Schemes . . . . .	35
Table 14.	CFI Query Identification String. . . . .	39
Table 15.	CFI System Interface String. . . . .	39
Table 16.	Device Geometry Definition. . . . .	40
Table 17.	CFI Primary Vendor-Specific Extended Query. . . . .	41
Table 18.	Allowed Operations During Erase/Program Suspend . . . . .	48
Table 19.	Memory Array Command Definitions . . . . .	54
Table 20.	Sector Protection Command Definitions . . . . .	55
Table 21.	Write Operation Status. . . . .	61
Table 22.	Test Specifications. . . . .	66

## Figures

Figure 1.	Asynchronous Read Operation .....	27
Figure 2.	End of Burst Indicator (IND/WAIT#) Timing for Linear 8-Word Burst Operation .....	29
Figure 3.	Initial Burst Delay Control .....	30
Figure 4.	Program Operation .....	45
Figure 5.	Erase Operation .....	48
Figure 6.	Data# Polling Algorithm.....	57
Figure 7.	Toggle Bit Algorithm.....	60
Figure 8.	Maximum Negative Overshoot Waveform.....	62
Figure 9.	Maximum Positive Overshoot Waveform.....	62
Figure 10.	I <sub>CC1</sub> Current vs. Time (Showing Active and Automatic Sleep Currents).....	65
Figure 11.	Typical I <sub>CC1</sub> vs. Frequency .....	65
Figure 12.	Test Setup.....	66
Figure 13.	Input Waveforms and Measurement Levels .....	66
Figure 14.	V <sub>CC</sub> and V <sub>IO</sub> Power-up Diagram.....	67
Figure 15.	Conventional Read Operations Timings.....	68
Figure 16.	Burst Mode Read.....	70
Figure 17.	Asynchronous Command Write Timing.....	70
Figure 18.	Synchronous Command Write/Read Timing.....	71
Figure 19.	RESET# Timings.....	72
Figure 20.	WP# Timing.....	72
Figure 21.	Chip/Sector Erase Operation Timings.....	74
Figure 22.	Back-to-Back Cycle Timings .....	74
Figure 23.	Data# Polling Timings (During Embedded Algorithms) .....	75
Figure 24.	Toggle Bit Timings (During Embedded Algorithms).....	75
Figure 25.	DQ2 vs. DQ6 for Erase/Erase Suspend Operations .....	76
Figure 26.	Synchronous Data Polling Timing/Toggle Bit Timings.....	76
Figure 27.	Sector Protect/Unprotect Timing Diagram .....	77
Figure 28.	Alternate CE# Controlled Write Operation Timings.....	78

## Product Selector Guide

Part Number		S29CD-G Flash Family (S29CD032G, S29CD016G)			
Standard Voltage Range:	$V_{CC} = 2.5 - 2.75 \text{ V}$ $V_{IO} = 1.65 - 2.75 \text{ V}$	Synchronous/Burst or Asynchronous			
Speed Option (Clock Rate)		OR (75 MHz) (32 Mb Only)	OP (66 MHz)	OM (56 MHz)	OJ (40 MHz)
Max Initial/Asynchronous Access Time, ns ( $t_{ACC}$ )		48	54	64	67
Max Burst Access Delay (ns)		7.5 FBGA	9 FBGA/ 9.5 PQFP	10 FBGA/ 10 PQFP	17
Max Clock Rate (MHz)		75	66	56	40
Min Initial Clock Delay (clock cycles)		3	3	3	2
Max CE# Access, ns ( $t_{CE}$ )		52	58	69	71
Max OE# Access, ns ( $t_{OE}$ )			20		28



## Ordering Information

The order number (Valid Combination) is formed by the following:

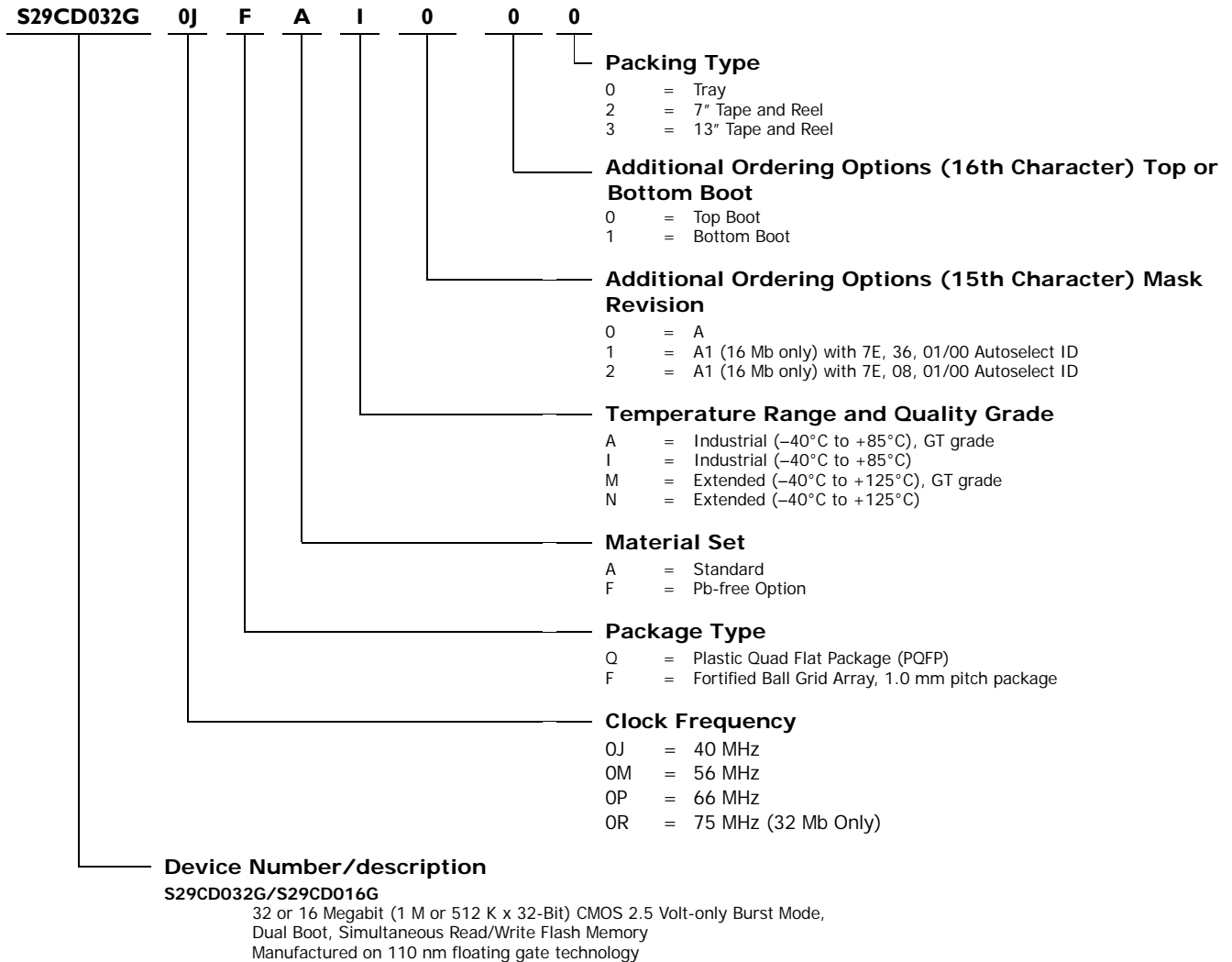

### Valid Combinations

Valid Combinations list configurations planned to be supported in volume for this device. Consult your local sales office to confirm availability of specific valid combinations and to check on newly released combinations.

Valid Combinations			
S29CD032G S29CD016G	OR (32 MB Only), OP, OM, OJ	QAI, QFI, QAN, QFN	00, 01
		FAI, FFI, FAN, FFN	

1. The ordering part number that appears on BGA packages omits the leading "S29".
2. Contact your local sales representative for GT grade options.
3. Refer to the KGD data sheet supplement for die/wafer sales.

## Block Diagram

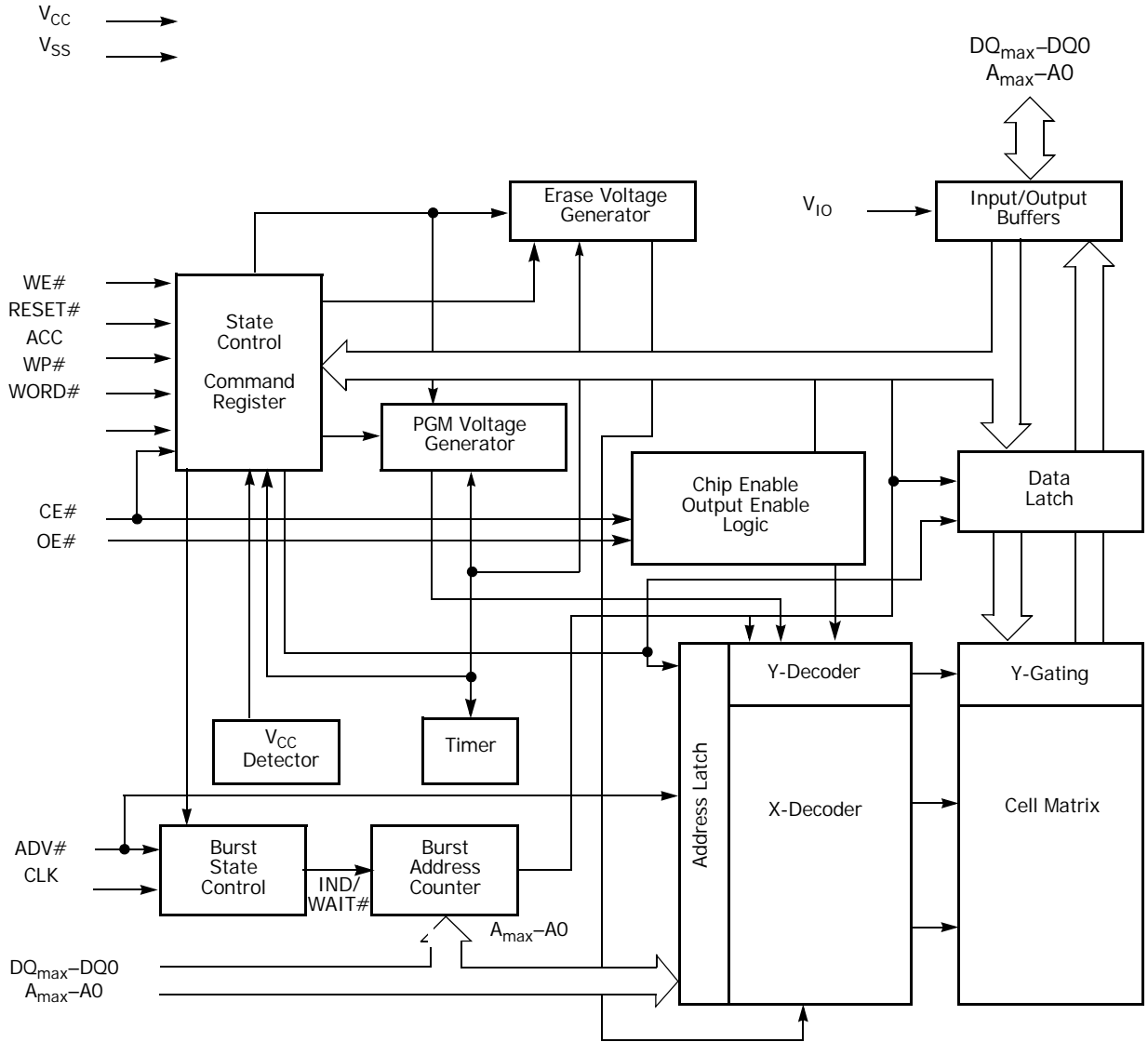

**Note:** Address bus is A19-A0 for 32 Mb device, A18-A0 for 16 Mb device. Data bus is D31-DQ0.

## Block Diagram of Simultaneous Read/Write Circuit

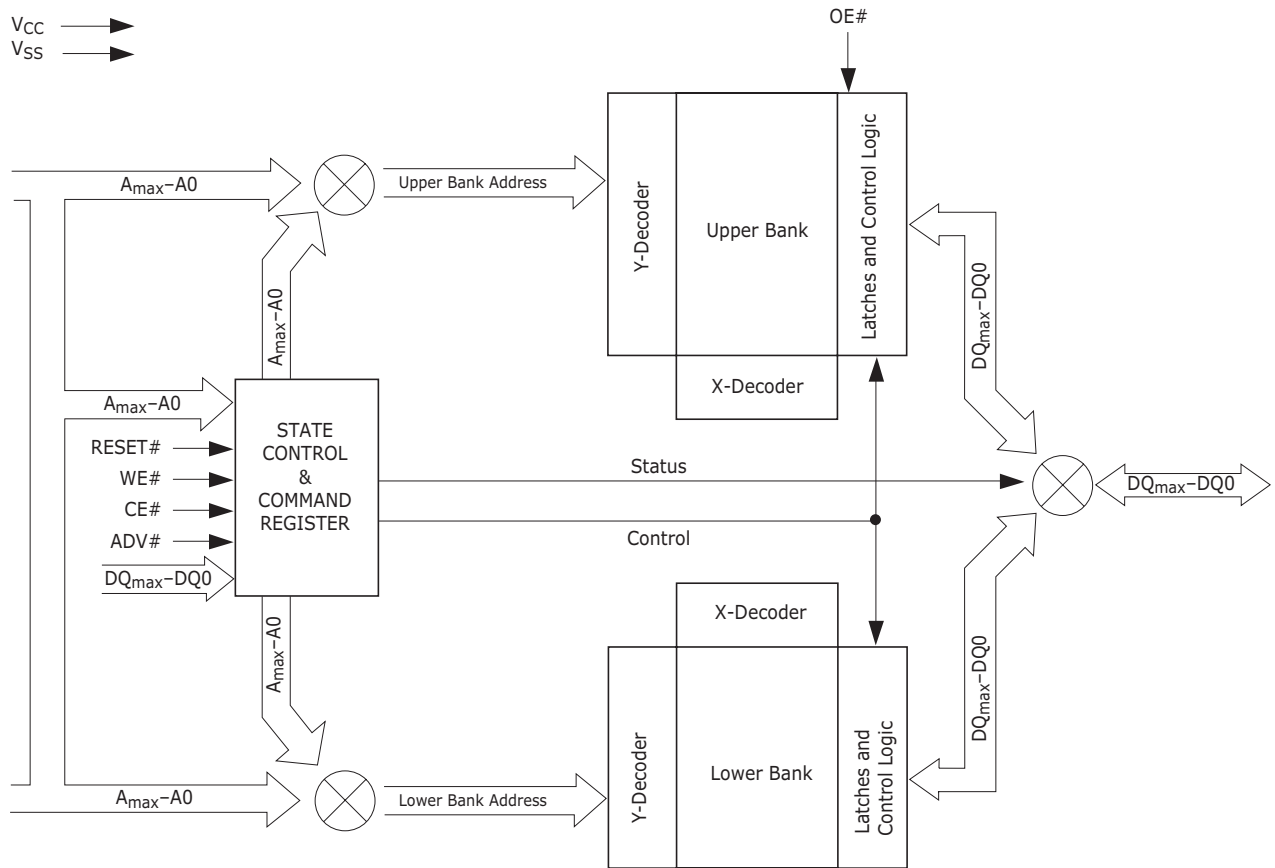

**Note:** Address bus is  $A_{19}-A_0$  for 32 Mb device,  $A_{18}-A_0$  for 16 Mb device. Data bus is  $D_{31}-DQ_0$ .

## Connection Diagrams

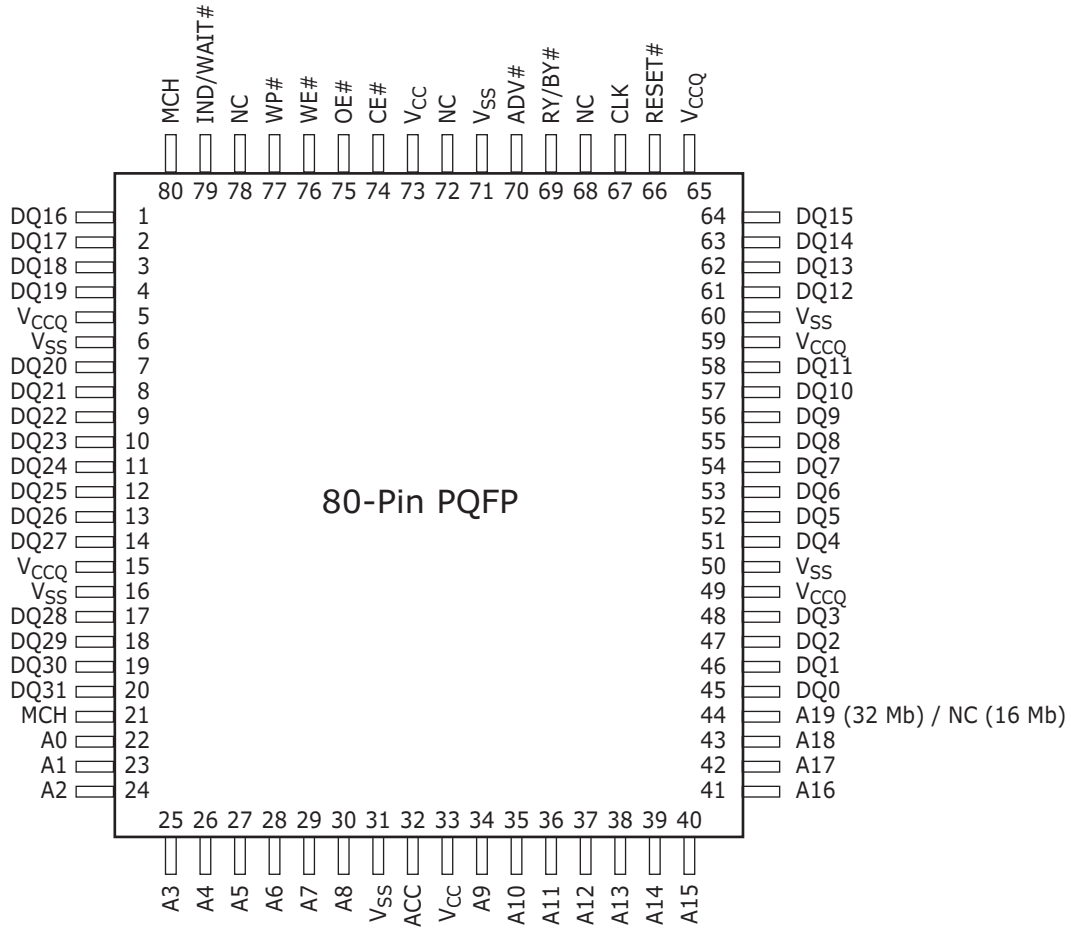

**Note:** On 16 Mb device, pin 44 (A19) is NC.

# Physical Dimensions

## PRQ080-80-Lead Plastic Quad Flat Package

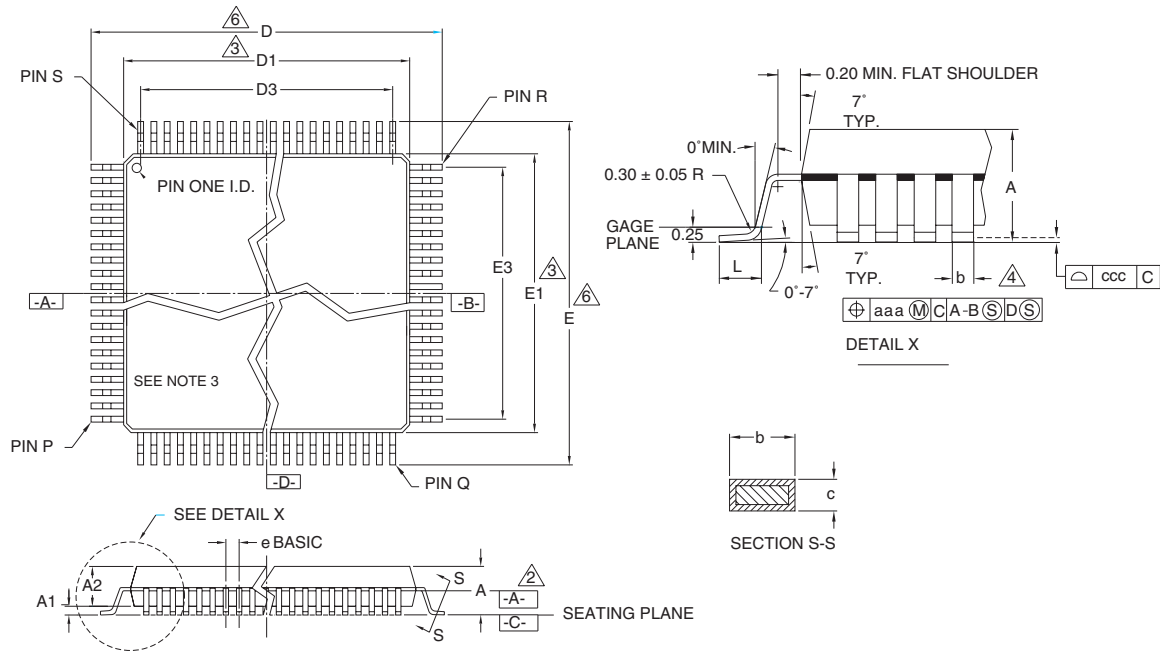

PACKAGE	PQR 080			NOTES
	MO-108(B)CB-1			
SYMBOL	MIN	NOM	MAX	
A	--	--	3.35	
A1	0.25	--	--	
A2	2.70	2.80	2.90	
b	0.30	--	0.45	SEE NOTE 4
c	0.15	--	0.23	
D	17.00	17.20	17.40	
D1	13.90	14.00	14.10	SEE NOTE 3
D3	--	12.0	--	REFERENCE
e	--	0.80	--	BASIC, SEE NOTE 7
E	23.00	23.20	23.40	
E1	19.90	20.00	20.10	SEE NOTE 3
E3	--	18.40	--	REFERENCE
aaa	---	0.20	---	
ccc		0.10		
L	0.73	0.88	1.03	
P		24		
Q		40		
R		64		
S		80		

**NOTES:**

- ALL DIMENSIONS AND TOLERANCES CONFORM TO ANSI Y14.5M-1982.
- DATUM PLANE [-A-] IS LOCATED AT THE MOLD PARTING LINE AND IS COINCIDENT WITH THE BOTTOM OF THE LEAD WHERE THE LEAD EXITS THE PLASTIC BODY.
- DIMENSIONS "D1" AND "E1" DO NOT INCLUDE MOLD PROTRUSION. ALLOWABLE PROTRUSION IS 0.25 mm PER SIDE. DIMENSIONS "D1" AND "E1" INCLUDE MOLD MISMATCH AND ARE DETERMINED AT DATUM PLANE [-A-].
- DIMENSION "B" DOES NOT INCLUDE DAMBAR PROTRUSION.
- CONTROLLING DIMENSIONS: MILLIMETER.
- DIMENSIONS "D" AND "E" ARE MEASURED FROM BOTH INNERMOST AND OUTERMOST POINTS.
- DEVIATION FROM LEAD-TIP TRUE POSITION SHALL BE WITHIN ±0.0076 mm FOR PITCH > 0.5 mm AND WITHIN ±0.04 FOR PITCH ≤ 0.5 mm.
- LEAD COPLANARITY SHALL BE WITHIN: (REFER TO 06-500)  
1 - 0.10 mm FOR DEVICES WITH LEAD PITCH OF 0.65 - 0.80 mm  
2 - 0.076 mm FOR DEVICES WITH LEAD PITCH OF 0.50 mm.  
COPLANARITY IS MEASURED PER SPECIFICATION 06-500.
- HALF SPAN (CENTER OF PACKAGE TO LEAD TIP) SHALL BE WITHIN ±0.0085".



## Connection Diagrams

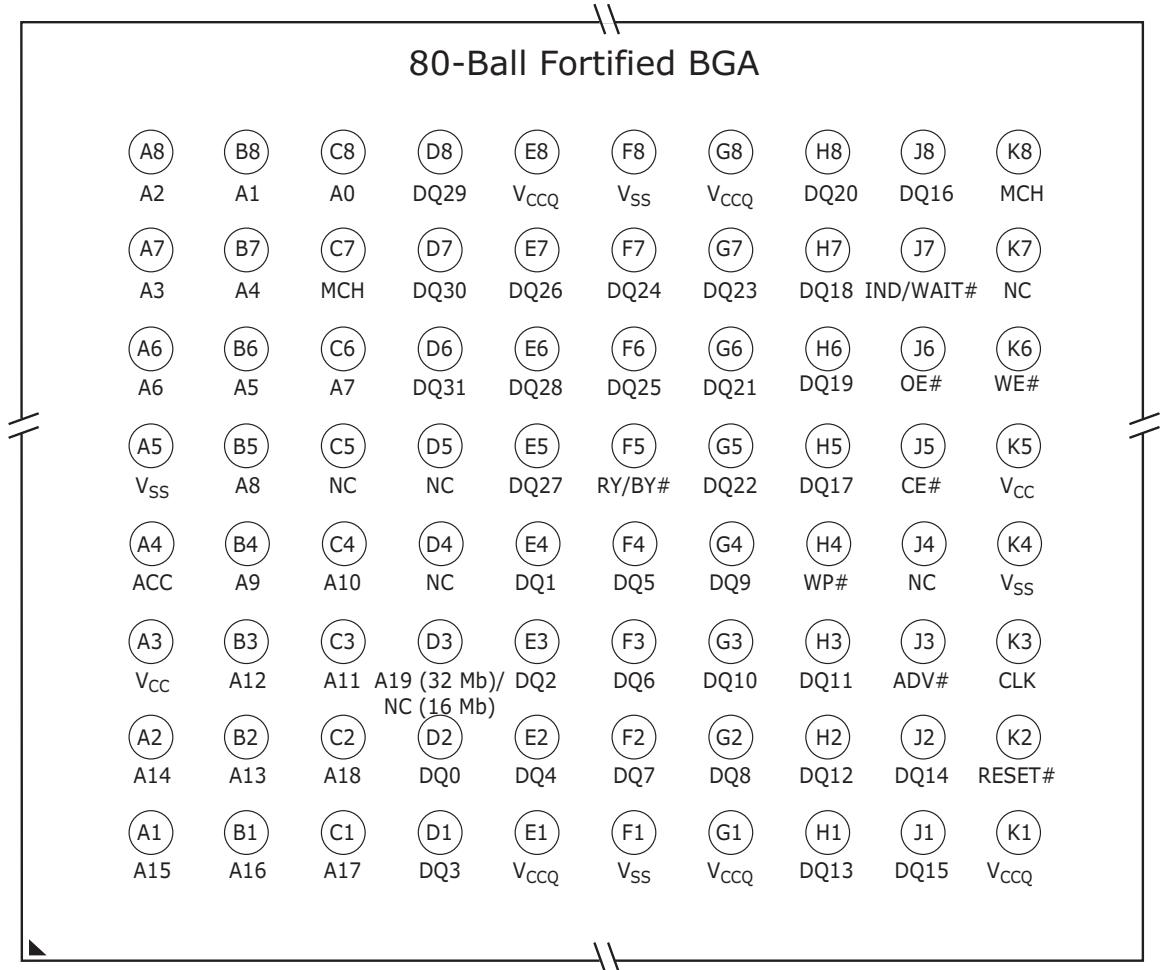

*Note:* On 16 Mb device, ball D3 (A19) is NC.

### Special Package Handling Instructions

Special handling is required for Flash Memory products in molded packages (BGA). The package and/or data integrity may be compromised if the package body is exposed to temperatures above 150°C for prolonged periods of time.

# Physical Dimensions

## LAA080-80-ball Fortified Ball Grid Array (13 x 11 mm)

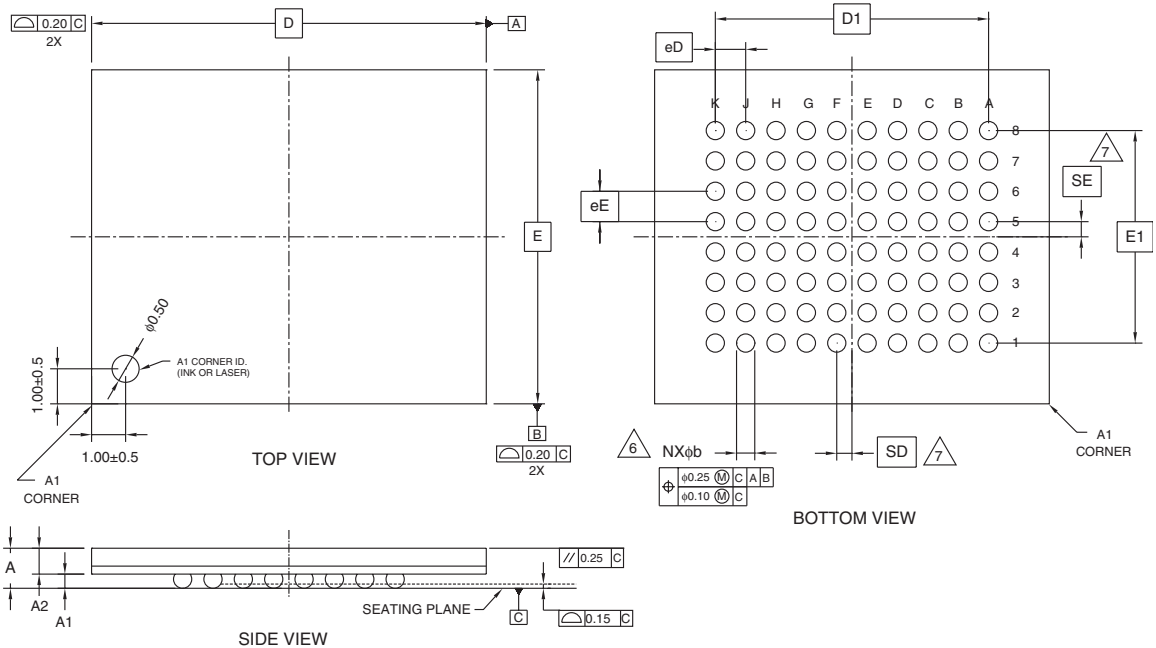

PACKAGE	LAA 080			NOTE
JEDEC	N/A			
	13.00 x 11.00 mm PACKAGE			
SYMBOL	MIN	NOM	MAX	
A	--	--	1.40	PROFILE HEIGHT
A1	0.40	--	--	STANDOFF
A2	0.60	--	--	BODY THICKNESS
D	13.00 BSC.			BODY SIZE
E	11.00 BSC.			BODY SIZE
D1	9.00 BSC.			MATRIX FOOTPRINT
E1	7.00 BSC.			MATRIX FOOTPRINT
MD	10			MATRIX SIZE D DIRECTION
ME	8			MATRIX SIZE E DIRECTION
N	80			BALL COUNT
φb	0.50	0.60	0.70	BALL DIAMETER
eD	1.00 BSC.			BALL PITCH - D DIRECTION
eE	1.00 BSC.			BALL PITCH - E DIRECTION
SD/SE	0.50 BSC			SOLDER BALL PLACEMENT

NOTES:

- DIMENSIONING AND TOLERANCING METHODS PER ASME Y14.5M-1994.
  - ALL DIMENSIONS ARE IN MILLIMETERS.
  - BALL POSITION DESIGNATION PER JESD 95-1, SPP-010 (EXCEPT AS NOTED).
  - [e] REPRESENTS THE SOLDER BALL GRID PITCH.
  - SYMBOL "MD" IS THE BALL ROW MATRIX SIZE IN THE "D" DIRECTION. SYMBOL "ME" IS THE BALL COLUMN MATRIX SIZE IN THE "E" DIRECTION. N IS THE TOTAL NUMBER OF SOLDER BALLS.
- ⚠ DIMENSION "b" IS MEASURED AT THE MAXIMUM BALL DIAMETER IN A PLANE PARALLEL TO DATUM C.
- ⚠ SD AND SE ARE MEASURED WITH RESPECT TO DATUMS A AND B AND DEFINE THE POSITION OF THE CENTER SOLDER BALL IN THE OUTER ROW. WHEN THERE IS AN ODD NUMBER OF SOLDER BALLS IN THE OUTER ROW PARALLEL TO THE D OR E DIMENSION, RESPECTIVELY, SD OR SE = 0.000. WHEN THERE IS AN EVEN NUMBER OF SOLDER BALLS IN THE OUTER ROW, SD OR SE = [e/2]
- N/A
  - "+" INDICATES THE THEORETICAL CENTER OF DEPOPULATED BALLS.

3214/38.12C

## Pin Configuration

A0–A19	=	20-bit address bus for 32 Mb device, (19-bit for 16 Mb). A9 supports 12 V autoselect inputs.
DQ0–DQ31	=	32-bit data inputs/outputs/float
CE#	=	Chip Enable Input. This signal is asynchronous relative to CLK for the burst mode.
OE#	=	Output Enable Input. This signal is asynchronous relative to CLK for the burst mode.
WE#	=	Write enable. This signal is asynchronous relative to CLK for the burst mode.
V <sub>SS</sub>	=	Device ground
NC	=	Pin not connected internally
RY/BY#	=	Ready/Busy output and open drain. When RY/BY# = V <sub>OH</sub> , the device is ready to accept read operations and commands. When RY/BY# = V <sub>OL</sub> , the device is either executing an embedded algorithm or the device is executing a hardware reset operation.
CLK	=	Clock Input that can be tied to the system or microprocessor clock and provides the fundamental timing and internal operating frequency.
ADV#	=	Load Burst Address input. Indicates that the valid address is present on the address inputs.
IND#	=	End of burst indicator for finite bursts only. IND is low when the last word in the burst sequence is at the data outputs.
WAIT#	=	Provides data valid feedback only when the burst length is set to continuous.
WP#	=	Write Protect input. When WP# = V <sub>OL</sub> , the two outermost bootblock sector in the 75% bank are write protected regardless of other sector protection configurations.
ACC	=	Acceleration input. When taken to 12 V, program and erase operations are accelerated. When not used for acceleration, ACC = V <sub>SS</sub> to V <sub>CC</sub> .
V <sub>IO</sub> (V <sub>CCQ</sub> )	=	Output Buffer Power Supply (1.65 V to 2.75 V)
V <sub>CC</sub>	=	Chip Power Supply (2.5 V to 2.75 V) or (3.00 V to 3.60 V)
RESET#	=	Hardware reset input
MCH	=	Must Connect High (to V <sub>CC</sub> )

## Logic Symbols

### S29CD032G

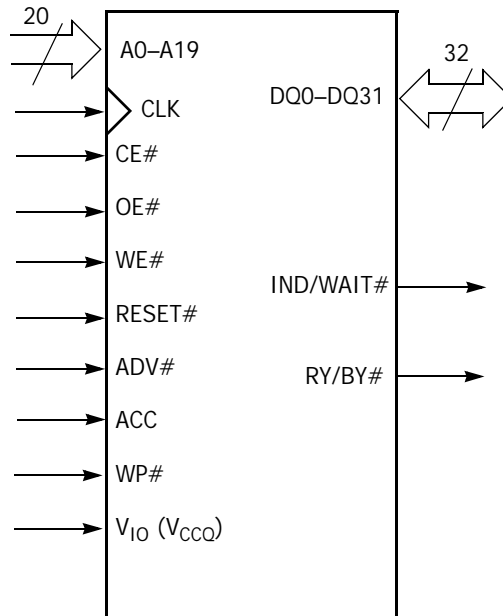

### S29CD016G

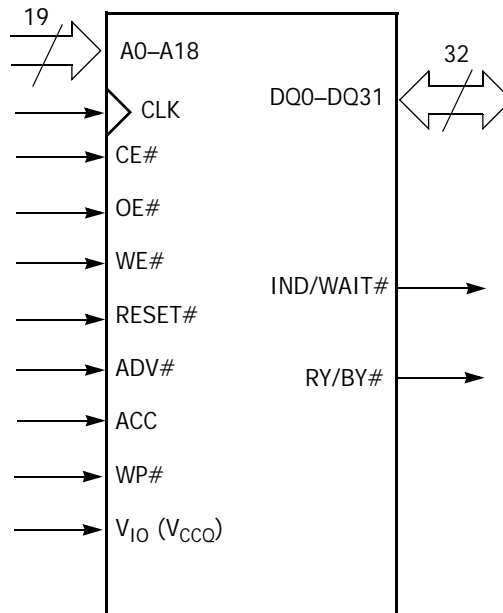

## Memory Map and Sector Protect Groups

The following tables lists the address ranges for all sectors and sector groups, and the sector sizes.

**Table 23. 32 Mb Memory Map and Sector Protect Groups for Ordering Option 00, Top Boot**

Sector	Sector Group Note 4	x32 Address Range (A19:A0)	Sector Size (KWords)	Sector	Sector Group Note 4	x32 Address Range (A19:A0)	Sector Size (KWords)
<b>Bank 0, Small Bank Note 2</b>				<b>Bank 1, Large Bank Note 2</b>			
SA0 Note 1	SG0	00000h–007FFh	2	SA23	SG12	40000h–43FFFh	16
SA1	SG1	00800h–00FFFh	2	SA24		44000h–47FFFh	16
SA2	SG2	01000h–017FFh	2	SA25		48000h–4BFFFh	16
SA3	SG3	01800h–01FFFh	2	SA26		4C000h–4FFFFh	16
SA4	SG4	02000h–027FFh	2	SA27	SG13	50000h–53FFFh	16
SA5	SG5	02800h–02FFFh	2	SA28		54000h–57FFFh	16
SA6	SG6	03000h–037FFh	2	SA29		58000h–5BFFFh	16
SA7	SG7	03800h–03FFFh	2	SA30		5C000h–5FFFFh	16
SA8	SG8	04000h–07FFFh	16	SA31	SG14	60000h–63FFFh	16
SA9		08000h–0BFFFh	16	SA32		64000h–67FFFh	16
SA10		0C000h–0FFFFh	16	SA33		68000h–6BFFFh	16
SA11	SG9	10000h–13FFFh	16	SA34		6C000h–6FFFFh	16
SA12		14000h–17FFFh	16	SA35	70000h–73FFFh	16	
SA13		18000h–1BFFFh	16	SA36	74000h–77FFFh	16	
SA14		1C000h–1FFFFh	16	SA37	78000h–7BFFFh	16	
SA15	SG10	20000h–23FFFh	16	SA38	7C000h–7FFFFh	16	
SA16		24000h–27FFFh	16	SA39	80000h–83FFFh	16	
SA17		28000h–2BFFFh	16	SA40	84000h–87FFFh	16	
SA18		2C000h–2FFFFh	16	SA41	88000h–8BFFFh	16	
SA19	SG11	30000h–33FFFh	16	SA42	8C000h–8FFFFh	16	
SA20		34000h–37FFFh	16	SA43	90000h–93FFFh	16	
SA21		38000h–3BFFFh	16	SA44	94000h–97FFFh	16	
SA22		3C000h–3FFFFh	16	SA45	98000h–9BFFFh	16	
				SA46	SG18	9C000h–9FFFFh	16
				SA47		A0000h–A3FFFh	16
				SA48		A4000h–A7FFFh	16
				SA49		A8000h–ABFFFh	16
				SA50	AC000h–AFFFFh	16	
				SA51	SG19	B0000h–B3FFFh	16
				SA52		B4000h–B7FFFh	16
				SA53		B8000h–BBFFFh	16
				SA54		BC000h–BFFFFh	16
				SA55	SG20	C0000h–C3FFFh	16
				SA56		C4000h–C7FFFh	16
				SA57		C8000h–CBFFFh	16
				SA58		CC000h–CFFFFh	16
				SA59	SG21	D0000h–D3FFFh	16
				SA60		D4000h–D7FFFh	16
				SA61		D8000h–DBFFFh	16
				SA62		DC000h–DFFFFh	16
				SA63	SG22	E0000h–E3FFFh	16
				SA64		E4000h–E7FFFh	16
				SA65		E8000h–EBFFFh	16
				SA66		EC000h–EFFFFh	16
				SA67	SG23	F0000h–F3FFFh	16
				SA68		F4000h–F7FFFh	16
				SA69		F8000h–FBFFFh	16
				SA70	SG24	FC000h–FC7FFh	2
				SA71	SG25	FC800h–FCFFFh	2
				SA72	SG26	FD000h–FD7FFh	2
				SA73	SG27	FD800h–FDFFFh	2
				SA74	SG28	FE000h–FE7FFh	2
				SA75	SG29	FE800h–FEFFFh	2
SA76 Note 3	SG30	FF000h–FF7FFh	2				
SA77 Note 3	SG31	FF800h–FFFFFh	2				

**Notes:**

1. Secured Silicon Sector overlays this sector when enabled.
2. The bank address is determined by A19 and A18. BA = 00 for Bank 0 and BA = 01, 10, or 11 for Bank 1.
3. This sector has the additional WP# pin sector protection feature.
4. Sector groups are for Sector Protection.

**Table 24. 32 Mb Memory Map and Sector Protect Groups for Ordering Option 0I, Bottom Boot**

Sector	Sector Group Note 4	x32 Address Range (A19:A0)	Sector Size (KDwords)	Sector	Sector Group Note 4	x32 Address Range (A19:A0)	Sector Size (KDwords)
<b>Bank 0, Large Bank Note 2</b>				<b>Bank 1, Small Bank (Note 2)</b>			
SA0 Note 1	SG0	00000h–00FFFh	2	SA55	SG20	C0000h–C3FFFh	16
SA1 Note 1	SG1	00800h–00FFFh	2	SA56		C4000h–C7FFFh	16
SA2	SG2	01000h–017FFFh	2	SA57		C8000h–CBFFFh	16
SA3	SG3	01800h–01FFFh	2	SA58		CC000h–CFFFFh	16
SA4	SG4	02000h–027FFFh	2	SA59	SG21	D0000h–D3FFFh	16
SA5	SG5	02800h–02FFFh	2	SA60		D4000h–D7FFFh	16
SA6	SG6	03000h–037FFFh	2	SA61		D8000h–DBFFFh	16
SA7	SG7	03800h–03FFFh	2	SA62		DC000h–DFFFFh	16
SA8	SG8	04000h–07FFFh	16	SA63	SG22	E0000h–E3FFFh	16
SA9		08000h–0BFFFh	16	SA64		E4000h–E7FFFh	16
SA10		0C000h–0FFFFh	16	SA65		E8000h–EBFFFh	16
SA11	SG9	10000h–13FFFh	16	SA66		EC000h–EFFFFh	16
SA12		14000h–17FFFh	16	SA67	F0000h–F3FFFh	16	
SA13		18000h–1BFFFh	16	SA68	F4000h–F7FFFh	16	
SA14		1C000h–1FFFFh	16	SA69	F8000h–FBFFFh	16	
SA15	SG10	20000h–23FFFh	16	SA70	SG24	FC000h–FC7FFFh	2
SA16		24000h–27FFFh	16	SA71	SG25	FC800h–FCFFFh	2
SA17		28000h–2BFFFh	16	SA72	SG26	FD000h–FD7FFFh	2
SA18		2C000h–2FFFFh	16	SA73	SG27	FD800h–FDFFFh	2
SA19	SG11	30000h–33FFFh	16	SA74	SG28	FE000h–FE7FFFh	2
SA20		34000h–37FFFh	16	SA75	SG29	FE800h–FEFFFh	2
SA21		38000h–3BFFFh	16	SA76	SG30	FF000h–FF7FFFh	2
SA22		3C000h–3FFFFh	16	SA77 Note 3	SG31	FF800h–FFFFFFh	2
SA23	SG12	40000h–43FFFh	16				
SA24		44000h–47FFFh	16				
SA25		48000h–4BFFFh	16				
SA26		4C000h–4FFFFh	16				
SA27	SG13	50000h–53FFFh	16				
SA28		54000h–57FFFh	16				
SA29		58000h–5BFFFh	16				
SA30		5C000h–5FFFFh	16				
SA31	SG14	60000h–63FFFh	16				
SA32		64000h–67FFFh	16				
SA33		68000h–6BFFFh	16				
SA35	SG15	70000h–73FFFh	16				
SA36		74000h–77FFFh	16				
SA37		78000h–7BFFFh	16				
SA38		7C000h–7FFFFh	16				
SA39	SG16	80000h–83FFFh	16				
SA40		84000h–87FFFh	16				
SA41		88000h–8BFFFh	16				
SA42		8C000h–8FFFFh	16				
SA43	SG17	90000h–93FFFh	16				
SA44		94000h–97FFFh	16				
SA45		98000h–9BFFFh	16				
SA46		9C000h–9FFFFh	16				
SA47	SG18	A0000h–A3FFFh	16				
SA48		A4000h–A7FFFh	16				
SA49		A8000h–ABFFFh	16				
SA50		AC000h–AFFFFh	16				
SA51	SG19	B0000h–B3FFFh	16				
SA52		B4000h–B7FFFh	16				
SA53		B8000h–BBFFFh	16				
SA54		BC000h–BFFFFh	16				

**Notes:**

1. This sector has the additional WP# pin sector protection feature.
2. The bank address is determined by A19 and A18. BA = 00, 01, or 10 for Bank 0 and BA = 11 for Bank 1.
3. Secured Silicon Sector overlays this sector when enabled.
4. Sector groups are for Sector Protection.

**Table 25. 16 Mb, Memory Map and Sector Protect Groups for Ordering Option 00, Top Boot**

Sector	Sector Group	x32 Address Range (A18:A0)	Sector Size (KDwords)	Sector	Sector Group	x32 Address Range (A18:A0)	Sector Size (KDwords)
<b>Bank 0, Small Bank <a href="#">Note 2</a></b>				<b>Bank 1, Large Bank <a href="#">Note 2</a></b>			
SA0 <a href="#">Note 1</a>	SG0	00000h–007FFh	2	SA15	SG10	20000h–23FFFh	16
SA1	SG1	00800h–00FFFh	2	SA16		24000h–27FFFh	16
SA2	SG2	01000h–017FFh	2	SA17		28000h–2BFFFh	16
SA3	SG3	01800h–01FFFh	2	SA18		2C000h–2FFFFh	16
SA4	SG4	02000h–027FFh	2	SA19	SG11	30000h–33FFFh	16
SA5	SG5	02800h–02FFFh	2	SA20		34000h–37FFFh	16
SA6	SG6	03000h–037FFh	2	SA21		38000h–3BFFFh	16
SA7	SG7	03800h–03FFFh	2	SA22		3C000h–3FFFFh	16
SA8	SG8	04000h–07FFFh	16	SA23	SG12	40000h–43FFFh	16
SA9		08000h–0BFFFh	16	SA24		44000h–47FFFh	16
SA10		0C000h–0FFFFh	16	SA25		48000h–4BFFFh	16
SA11	SG9	10000h–13FFFh	16	SA26		4C000h–4FFFFh	16
SA12		14000h–17FFFh	16	SA27	SG13	50000h–53FFFh	16
SA13		18000h–1BFFFh	16	SA28		54000h–57FFFh	16
SA14		1C000h–1FFFFh	16	SA29		58000h–5BFFFh	16
				SA30		5C000h–5FFFFh	16
				SA31	SG14	60000h–63FFFh	16
				SA32		64000h–67FFFh	16
				SA33		68000h–6BFFFh	16
				SA34		6C000h–6FFFFh	16
				SA35	SG15	70000h–73FFFh	16
				SA36		74000h–77FFFh	16
				SA37		78000h–7BFFFh	16
				SA38	SG16	7C000h–7C7FFh	2
				SA39	SG17	7C800h–7CFFFh	2
				SA40	SG18	7D000h–7D7FFh	2
				SA41	SG19	7D800h–7DFFFh	2
				SA42	SG20	7E000h–7E7FFh	2
				SA43	SG21	7E800h–7EFFFh	2
				SA44 <a href="#">Note 2</a>	SG22	7F000h–7F7FFh	2
				SA45 <a href="#">Note 2</a>	SG23	7F800h–7FFFFh	2

**Notes:**

1. Secured Silicon Sector overlays this sector when enabled.
2. The bank address is determined by A18 and A17. BA = 00 for Bank 1 and BA = 01, 10, or 11 for Bank 2.
3. This sector has the additional WP# pin sector protection feature.
4. Sector groups are for Sector Protection.

**Table 26. 16 Mb, Memory Map and Sector Protect Groups for Ordering Option 00, Bottom Boot**

Sector	Sector Group Note 4	x32 Address Range (A19:A0)	Sector Size (KDwords)
<b>Bank 0, Large Bank Note 2</b>			
SA0 Note 1	SG0	00000h–007FFh	2
SA1 Note 1	SG1	00800h–00FFFh	2
SA2	SG2	01000h–017FFh	2
SA3	SG3	01800h–01FFFh	2
SA4	SG4	02000h–027FFh	2
SA5	SG5	02800h–02FFFh	2
SA6	SG6	03000h–037FFh	2
SA7	SG7	03800h–03FFFh	2
SA8	SG8	04000h–07FFFh	16
SA9		08000h–0BFFFh	16
SA10		0C000h–0FFFFh	16
SA11	SG9	10000h–13FFFh	16
SA12		14000h–17FFFh	16
SA13		18000h–1BFFFh	16
SA14		1C000h–1FFFFh	16
SA15	SG10	20000h–23FFFh	16
SA16		24000h–27FFFh	16
SA17		28000h–2BFFFh	16
SA18		2C000h–2FFFFh	16
SA19	SG11	30000h–33FFFh	16
SA20		34000h–37FFFh	16
SA21		38000h–3BFFFh	16
SA22		3C000h–3FFFFh	16
SA23	SG12	40000h–43FFFh	16
SA24		44000h–47FFFh	16
SA25		48000h–4BFFFh	16
SA26		4C000h–4FFFFh	16
SA27	SG13	50000h–53FFFh	16
SA28		54000h–57FFFh	16
SA29		58000h–5BFFFh	16
SA30		5C000h–5FFFFh	16
SA31	SG14	60000h–63FFFh	16
SA32		64000h–67FFFh	16
SA33		68000h–6BFFFh	16
SA34		6C000h–6FFFFh	16

Sector	Sector Group Note 4	x32 Address Range (A19:A0)	Sector Size (KDwords)
<b>Bank 1, Small Bank Note 2</b>			
SA35	SG15	70000h–73FFFh	16
SA36		74000h–77FFFh	16
SA37		78000h–7BFFFh	16
SA38	SG16	7C000h–7C7FFh	2
SA39	SG17	7C800h–7CFFFh	2
SA40	SG18	7D000h–7D7FFh	2
SA41	SG19	7D800h–7DFFFh	2
SA42	SG20	7E000h–7E7FFh	2
SA43	SG21	7E800h–7EFFFh	2
SA44	SG22	7F000h–7F7FFh	2
SA45	SG23	7F800h–7FFFFh	2

**Notes:**









1. This sector has the additional WP# pin sector protection feature.
2. The bank address is determined by A18 and A17. BA = 00 for Bank 1 and BA = 01, 10, or 11 for Bank 2.
3. Secured Silicon Sector overlays this sector when enabled.
4. Sector groups are for Sector Protection.



## Device Operations

This section describes the requirements and use of the device bus operations, which are initiated through the internal command register. The command register itself does not occupy any addressable memory location. The register is composed of latches that store the commands, along with the address and data information needed to execute the command. The contents of the register serve as inputs to the internal state machine. The state machine outputs dictate the function of the device. Table 27 lists the device bus operations, the inputs and control levels they require, and the resulting output. The following subsections describe each of these operations in further detail.

**Table 27. Device Bus Operation**

Operation	CE#	OE#	WE#	RESET#	CLK	ADV#	Addresses	Data (DQ0–DQ31)
Read	L	L	H	H	X	X	A <sub>IN</sub>	D <sub>OUT</sub>
Asynchronous Write	L	H	L	H	X	X	A <sub>IN</sub>	D <sub>IN</sub>
Synchronous Write	L	H	L	H			A <sub>IN</sub>	D <sub>IN</sub>
Standby (CE#)	H	X	X	H	X	X	X	HIGH Z
Output Disable	L	H	H	H	X	X	HIGH Z	HIGH Z
Reset	X	X	X	L	X	X	X	HIGH Z
PPB Protection Status (Note 2)	L	L	H	H	X	X	Sector Address, A9 = V <sub>ID</sub> , A7 – A0 = 02h	00000001h, (protected) A6 = H
								00000000h (unprotect) A6 = L
Burst Read Operations								
Load Starting Burst Address	L	X	H	H			A <sub>IN</sub>	X
Advance Burst to next address with appropriate Data presented on the Data bus	L	L	H	H		H	X	Burst Data Out
Terminate Current Burst Read Cycle	H	X	H	H		X	X	HIGH Z
Terminate Current Burst Read Cycle with RESET#	X	X	H	L	X	X	X	HIGH Z
Terminate Current Burst Read Cycle; Start New Burst Read Cycle	L	H	H	H			A <sub>IN</sub>	X

**Legend:** L = Logic Low = V<sub>IL</sub>, H = Logic High = V<sub>IH</sub>, X = Don't care.

**Notes:**

1. WP# controls the two outermost sectors of the top boot block or the two outermost sectors of the bottom boot block.
2. DQ0 reflects the sector PPB (or sector group PPB) and DQ1 reflects the DYB

## VersatileI/O™ (V<sub>IO</sub>) Control

The VersatileI/O (V<sub>IO</sub>) control allows the host system to set the voltage levels that the device generates at its data outputs and the voltages tolerated at its data inputs to the same voltage level that is asserted on the V<sub>IO</sub> pin.

The output voltage generated on the device is determined based on the V<sub>IO</sub> (V<sub>CCQ</sub>) level. For the 2.6 V V<sub>CC</sub> Mask Option, a V<sub>IO</sub> of 1.65 V – 1.95 V allows the device to interface with I/Os lower than 2.5 V. V<sub>CC</sub> = V<sub>IO</sub> (2.5 V to 2.75V) make the device appear as a 2.5 V only.

## Requirements for Reading Array Data

To read array data from the outputs, the system must drive the CE# and OE# pins to V<sub>IL</sub>. CE# is the power control and selects the device. OE# is the output control and gates array data to the output pins. WE# should remain at V<sub>IH</sub>.

The internal state machine is set for reading array data upon device power-up, or after a hardware reset. This ensures that no spurious alteration of the memory content occurs during the power transition. No command is necessary in this mode to obtain array data. Standard microprocessor read cycles that assert valid addresses on the device address inputs produce valid data on the device data outputs. The device remains enabled for read access until the command register contents are altered.

Address access time ( $t_{ACC}$ ) is the delay from stable addresses to valid output data. The chip enable access time ( $t_{CE}$ ) is the delay from stable addresses and stable CE# to valid data at the output pins. The output enable access time ( $t_{OE}$ ) is the delay from the falling edge of OE# to valid data at the output pins (assuming the addresses were stable for at least  $t_{ACC}-t_{OE}$  time and CE# is asserted for at least  $t_{CE}-t_{OE}$  time).

See [Reading Array Data in Non-burst Mode](#) and [Reading Array Data in Burst Mode](#) for more information. Refer to the [Asynchronous Read Operations](#) table for timing specifications and to [Figure 15](#) for the timing diagram.  $I_{CC1}$  in the DC Characteristics table represents the active current specification for reading array data.

## Simultaneous Read/Write Operations Overview

### Overview

The Simultaneous Read/Write feature allows embedded program or embedded erase operation to be executed in the Small Bank, while reading from the Large Bank. The opposite case is not valid.

**Table 28. Allowable Conditions for Simultaneous Operation**

Small Bank	Large Bank
Embedded Erase	Burst (Synchronous) Read or Asynchronous Read
Embedded Program	Burst (Synchronous) Read or Asynchronous Read

**Note:**

Please refer to the Memory Map [Table 23](#), [Table 24](#), [Table 25](#), and [Table 26](#) for Small and Large Bank assignments.

### Program/Erase Suspend and Simultaneous Operation

There is no restriction to implementing a program-suspend or erase-suspend during a simultaneous operation.

### Common Flash Interface (CFI) and Password Program/Verify and Simultaneous Operation

Simultaneous read/write operation is disabled during the CFI and Password Program/Verify operation, including PPB program/erase and unlocking a password operation. Only array data can be read in the Large Bank during a simultaneous operation.

## Writing Commands/Command Sequences

To write a command or command sequence (which includes programming data to the device and erasing sectors of memory), the system must drive WE# and CE# to  $V_{IL}$ , and OE# to  $V_{IH}$ .

The device features an **Unlock Bypass** mode to facilitate faster programming. Once the device enters the Unlock Bypass mode, only two write cycles are required to program a word or byte, instead of four. See [Sector Erase and Program Suspend Command on page 47](#) for details on programming data to the device using both standard and Unlock Bypass command sequences.

An erase operation can erase one sector, multiple sectors, or the entire device. [Table 23](#), [Table 24](#), [Table 25](#), and [Table 26](#) indicate the address space that each sector occupies. A *sector address* consists of the address bits required to uniquely select a sector. See [Command Definitions on page 42](#) for details on erasing a sector or the entire chip, or suspending/resuming the erase operation.

When in Synchronous read mode configuration, the device is able to perform both asynchronous and synchronous write operations. CLK and ADV# address latch is supported in synchronous programming mode. During a synchronous write operation, to write a command or command sequence, (which includes programming data to the device and erasing sectors of memory), the system must drive ADV# and CE# to VIL, and OE# to VIH when providing an address to the device, and drive WE# and CE# to VIL, and CE# to VIH, when writing commands or data.

### Accelerated Program and Erase Operations

The device offers accelerated program/erase operations through the ACC pin. When the system asserts  $V_{HH}$  (12V) on the ACC pin, the device automatically enters the Unlock Bypass mode. The system may then write the two-cycle Unlock Bypass program command sequence to do accelerated programming. The device uses the higher voltage on the ACC pin to accelerate the operation. A sector that is being protected with the WP# pin is protected during accelerated program or Erase.

**Note:** The ACC pin must not be at  $V_{HH}$  during any operation other than accelerated programming, or device damage can result.

### Autoselect Functions

If the system writes the autoselect command sequence, the device enters the autoselect mode. The system can then read autoselect codes from the internal register (which is separate from the memory array) on DQ7–DQ0. Standard read cycle timings apply in this mode. See [Autoselect Mode on page 26](#) and [Autoselect Command on page 43](#) for more information.

## Automatic Sleep Mode (ASM)

The automatic sleep mode minimizes Flash device energy consumption. While in asynchronous mode, the device automatically enables this mode when addresses remain stable for  $t_{ACC} + 60$  ns. The automatic sleep mode is independent of the CE#, WE# and OE# control signals. Standard address access timings provide new data when addresses are changed. While in sleep mode, output data is latched and always available to the system. While in synchronous mode, the device automatically enables this mode when either the first active CLK level is greater than  $t_{ACC}$  or the CLK runs slower than 5 MHz. Note that a new burst operation is required to provide new data.

$I_{CC8}$  in [DC Characteristics on page 64](#) represents the automatic sleep mode current specification.

### Standby Mode

When the system is not responding or writing to the device, it can place the device in the standby mode. In this mode, current consumption is greatly reduced, and the outputs are placed in the high impedance state, independent of the OE# input.

The device enters the CMOS standby mode when the CE# and RESET# inputs are both held at  $V_{CC} \pm 0.2$  V. The device requires standard access time ( $t_{CE}$ ) for read access, before it is ready to read data.

If the device is deselected during erasure or programming, the device draws active current until the operation is completed.

$I_{CC5}$  in [DC Characteristics on page 64](#) represents the standby current specification.

**Caution:** entering the standby mode via the RESET# pin also resets the device to the read mode and floats the data I/O pins. Furthermore, entering  $I_{CC7}$  during a program or erase operation

leaves erroneous data in the address locations being operated on at the time of the RESET# pulse. These locations require updating after the device resumes standard operations. See [RESET#: Hardware Reset Pin on page 26](#) for further discussion of the RESET# pin and its functions.

## RESET#: Hardware Reset Pin

The RESET# pin is an active low signal that is used to reset the device under any circumstances. A logic 0 on this pin forces the device out of any mode that is currently executing back to the reset state. The RESET# pin may be tied to the system reset circuitry. A system reset would thus also reset the device. To avoid a potential bus contention during a system reset, the device is isolated from the DQ data bus by tristating the data output pins for the duration of the RESET pulse. All pins are *don't cares* during the reset operation.

If RESET# is asserted during a program or erase operation, the RY/BY# pin remains low until the reset operation is internally complete. This action requires between 1  $\mu$ s and 7  $\mu$ s for either Chip Erase or Sector Erase. The RY/BY# pin can be used to determine when the reset operation is complete. Otherwise, allow for the maximum reset time of 11  $\mu$ s. If RESET# is asserted when a program or erase operation is not executing (RY/BY# = 1), the reset operation completes within 500 ns. The Simultaneous Read/Write feature of this device allows the user to read a bank after 500 ns if the bank was in the read/reset mode at the time RESET# was asserted. If one of the banks was in the middle of either a program or erase operation when RESET# was asserted, the user must wait 11  $\mu$ s before accessing that bank.

Asserting RESET# during a program or erase operation leaves erroneous data stored in the address locations being operated on at the time of device reset. These locations need updating after the reset operation is complete. See [Figure 19, RESET# Timings, on page 72](#) for timing specifications.

Asserting RESET# active during  $V_{CC}$  and  $V_{IO}$  power up is required to guarantee proper device initialization until  $V_{CC}$  and  $V_{IO}$  reaches steady state voltages.

## Output Disable Mode

See [Table 27 on page 23](#) Device Bus Operation for OE# Operation in Output Disable Mode.

## Autoselect Mode

The autoselect mode provides manufacturer and device identification, and sector protection verification, through identifier codes output on DQ7–DQ0. This mode is primarily intended for programming equipment to automatically match a device to be programmed with its corresponding programming algorithm. However, the autoselect codes can also be accessed in-system through the command register.

When using programming equipment, the autoselect mode requires  $V_{ID}$  on address pin A9. Address pins A6, A1, and A0 must be as shown in [Table 24 on page 20](#) (top boot devices) or [Table 25 on page 21](#) (bottom boot devices). In addition, when verifying sector protection, the sector address must appear on the appropriate highest order address bits (see [Table 23 on page 19](#) through [Table 26 on page 22](#)). [Table 29](#) shows the remaining address bits that are don't care. When all necessary bits are set as required, the programming equipment may then read the corresponding identifier code on DQ7–DQ0.

To access the autoselect codes in-system, the host system can issue the autoselect command via the command. This method does not require  $V_{ID}$ . See [Command Definitions on page 42](#) for details on using the autoselect mode.

**Table 29. S29CD-G Flash Family Autoselect Codes (High Voltage Method)**

Description	CE#	OE#	WE#	A19 to A11	A10	A9	A8	A7	A6	A5 to A4	A3	A2	A1	A0	DQ7 to DQ0
Manufacturer ID: Spansion	L	L	H	X	X	V <sub>ID</sub>	X	X	L	X	X	X	L	L	0001h
Autoselect Device Code	Read Cycle 1	L	L	H	X	X	V <sub>ID</sub>	X	L	L	X	L	L	L	007Eh
															0036h (16Mb)
	Read Cycle 2	L	L	H	X	X	V <sub>ID</sub>	X	L	L	L	H	H	H	0009h (32Mb)
															0000h Ordering Option 00
Read Cycle 3	L	L	H	X	X	V <sub>ID</sub>	X	L	L	L	H	H	H	H	0001h Ordering Option 01
															0000h (unprotected)
PPB Protection Status	L	L	H	SA	X	V <sub>ID</sub>	X	L	L	L	L	L	H	L	0000h (protected)
															0001h (unprotected)

**Legend:** L = Logic Low = V<sub>IL</sub>, H = Logic High = V<sub>IH</sub>, SA = Sector Address, X = Don't care.

**Note:** The autoselect codes can also be accessed in-system via command sequences. See Table 40 on page 48 and Table 42 on page 55.

### Asynchronous Read Operation (Non-Burst)

The device has two control functions which must be satisfied in order to obtain data at the outputs. CE# is the power control and is used for device selection. OE# is the output control and is used to gate data to the output pins if the device is selected. The device is powered-up in an asynchronous read mode. In the asynchronous mode the device has two control functions which must be satisfied in order to obtain data at the outputs. CE# is the power control and is used for device selection. OE# is the output control and is used to gate data to the output pins if the device is selected.

Address access time (t<sub>ACC</sub>) is equal to the delay from stable addresses to valid output data. The chip enable access time (t<sub>CE</sub>) is the delay from the stable addresses and stable CE# to valid data at the output pins. The output enable access time is the delay from the falling edge of OE# to valid data at the output pins (assuming the addresses are stable for at least t<sub>ACC</sub>-t<sub>OE</sub> time).

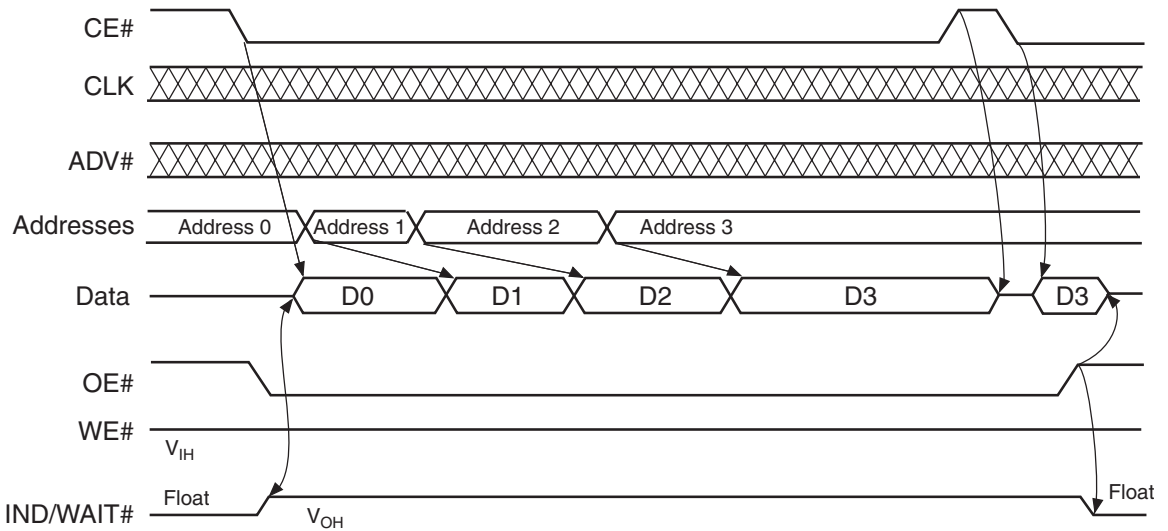

**Note:** Operation is shown for the 32-bit data bus. For the 16-bit data bus, A-1 is required.

**Figure 1. Asynchronous Read Operation**

### Synchronous (Burst) Read Operation

The device is capable of performing burst read operations to improve total system data throughput. The 2, 4, and 8 double word accesses are configurable as linear burst accesses. All burst

operations provide wrap around linear burst accesses. Additional options for all burst modes include initial access delay configurations (2–16 CLKs) Device configuration for burst mode operation is accomplished by writing the Configuration Register with the desired burst configuration information. Once the Configuration Register is written to enable burst mode operation, all subsequent reads from the array are returned using the burst mode protocols. Like the main memory access, the Secured Silicon Sector memory is accessed with the same burst or asynchronous timing as defined in the Configuration Register. However, the user must recognize burst operations past the 256 byte Secured Silicon boundary returns invalid data.

Burst read operations occur only to the main flash memory arrays. The Configuration Register and protection bits are treated as single cycle reads, even when burst mode is enabled. Read operations to these locations results in the data remaining valid while OE# is at V<sub>IL</sub>, regardless of the number of CLK cycles applied to the device.

### Linear Burst Read Operations

Linear burst read mode reads either 2, 4, or 8 double words (1 double word = 32 bits). (See Table 30 for all valid burst output sequences). The IND/WAIT# pin transitions active (V<sub>IL</sub>) during the last transfer of data during a linear burst read before a wrap around, indicating that the system should initiate another ADV# to start the next burst access. If the system continues to clock the device, the next access wraps around to the starting address of the previous burst access. The IND/WAIT# signal remains inactive (floating) when not active. See Table 30 for a complete 32 data bus interface order.

**Table 30. 32- Bit Linear and Burst Data Order**

Data Transfer Sequence (Independent of the WORD# pin)	Output Data Sequence (Initial Access Address)
Two Linear Data Transfers	0-1 (A0 = 0) 1-0 (A0 = 1)
Four Linear Data Transfers	0-1-2-3 (A0:A-1/A1-A0 = 00) 1-2-3-0 (A0:A-1/A1-A0 = 01) 2-3-0-1 (A:A-1/A1-A0 = 10) 3-0-1-2 (A0:A-1/A1-A0 = 11)
Eight Linear Data Transfers	0-1-2-3-4-5-6-7 (A1:A-1A2-A0 = 000) 1-2-3-4-5-6-7-0 (A1:A-1/A2-A0 = 001) 2-3-4-5-6-7-0-1 (A1:A-1/A2-A0 = 010) 3-4-5-6-7-0-1-2 (A1:A-1/A2-A0 = 011) 4-5-6-7-0-1-2-3 (A1:A-1/A2-A0 = 100) 5-6-7-0-1-2-3-4 (A1:A-1/A2-A0 = 101) 6-7-0-1-2-3-4-5 (A1:A-1/A2-A0 = 110) 7-0-1-2-3-4-5-6 (A1:A-1/A2-A0 = 111)

#### CE# Control in Linear Mode

The CE# (Chip Enable) pin enables the device during read mode operations. CE# must meet the required burst read setup times for burst cycle initiation. If CE# is taken to V<sub>IH</sub> at any time during the burst linear or burst cycle, the device immediately exits the burst sequence and floats the DQ bus signal. Restarting a burst cycle is accomplished by taking CE# and ADV# to V<sub>IL</sub>.

#### ADV# Control In Linear Mode

The ADV# (Address Valid) pin is used to initiate a linear burst cycle at the clock edge when CE# and ADV# are at V<sub>IL</sub> and the device is configured for either linear burst mode operation. A burst access is initiated and the address is latched on the first rising CLK edge when ADV# is active or upon a rising ADV# edge, whichever occurs first. If the ADV# signal is taken to V<sub>IL</sub> prior to the end of a linear burst sequence, the previous address is discarded and subsequent burst transfers are invalid until ADV# transitions to V<sub>IH</sub> before a clock edge, which initiates a new burst sequence.

### RESET# Control in Linear Mode

The RESET# pin immediately halts the linear burst access when taken to  $V_{IL}$ . The DQ data bus signal float. Additionally, the Configuration Register contents are reset back to the default condition where the device is placed in asynchronous access mode.

### OE# Control in Linear Mode

The OE# (Output Enable) pin is used to enable the linear burst data on the DQ data bus pin. De-asserting the OE# pin to  $V_{IH}$  during a burst operation floats the data bus. However, the device continues to operate internally as if the burst sequence continues until the linear burst is complete. The OE# pin does not halt the burst sequence, this is accomplished by either taking CE# to  $V_{IH}$  or re-issuing a new ADV# pulse. The DQ bus remains in the float state until OE# is taken to  $V_{IL}$ .

### IND/WAIT# Operation in Linear Mode

The IND/WAIT#, or End of Burst Indicator signal (when in linear modes), informs the system that the last address of a burst sequence is on the DQ data bus. For example, if a 2-double-word linear burst access is enabled using a 16-bit DQ bus ( $WORD# = V_{IL}$ ), the IND/WAIT# signal transitions active on the second access. If the same scenario is used, the IND/WAIT# signal has the same delay and setup timing as the DQ pins. Also, the IND/WAIT# signal is controlled by the OE# signal. If OE# is at  $V_{IH}$ , the IND/WAIT# signal floats and is not driven. If OE# is at  $V_{IL}$ , the IND/WAIT# signal is driven at  $V_{IH}$  until it transitions to  $V_{IL}$  indicating the end of burst sequence. The IND/WAIT# signal timing and duration is (See [Configuration Register on page 31](#) for more information). The following table lists the valid combinations of the Configuration Register bits that impact the IND/WAIT# timing.

**Table 31. Valid Configuration Register Bit Definition for IND/WAIT#**

DOC	WC	CC	Definition
0	0	1	IND/WAIT# = $V_{IL}$ for 1-CLK cycle, Active on last transfer, Driven on rising CLD edge
0	1	1	IND/WAIT# = $V_{IL}$ for 1-CLK cycle, Active on second to last transfer, Driven on rising CLK edge

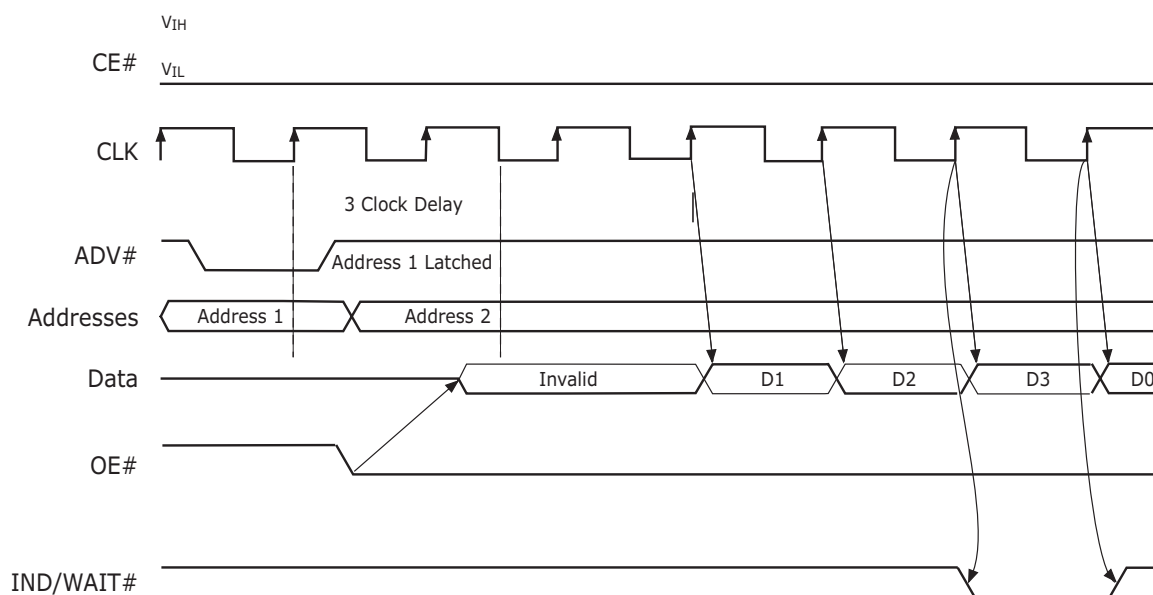

**Note:** Operation is shown for the 32-bit data bus. Figure shown with 3-CLK initial access delay configuration, linear address, 4-doubleword burst, output on rising CLD edge, data hold for 1-CLK, IND/WAIT# asserted on the last transfer before wrap-around.

**Figure 2. End of Burst Indicator (IND/WAIT#) Timing for Linear 8-Word Burst Operation**



### Burst Access Timing Control

In addition to the IND/WAIT# signal control, burst controls exist in the Control Register for initial access delay, delivery of data on the CLK edge, and the length of time data is held.

### Initial Burst Access Delay Control

The device contains options for initial access delay of a burst access. The initial access delay has no effect on asynchronous read operations.

Burst Initial Access Delay is defined as the number of clock cycles that must elapse from the first valid clock edge after ADV# assertion (or the rising edge of ADV#) until the first valid CLK edge when the data is valid.

The burst access is initiated and the address is latched on the first rising CLK edge when ADV# is active or upon a rising ADV# edge, whichever comes first. (Table 32 describes the initial access delay configurations.)

**Table 32. Burst Initial Access Delay**

CR13	CR12	CR11	CR10	Initial Burst Access (CLK cycles)
				40 MHz (OJ), 56 MHz (OM), 66 MHz (OP), 75 MHz (OR, 32 Mb only)
0	0	0	0	2
0	0	0	1	3
0	0	1	0	4
0	0	1	1	5
0	1	0	0	6
0	1	0	1	7
0	1	1	0	8
0	1	1	1	9

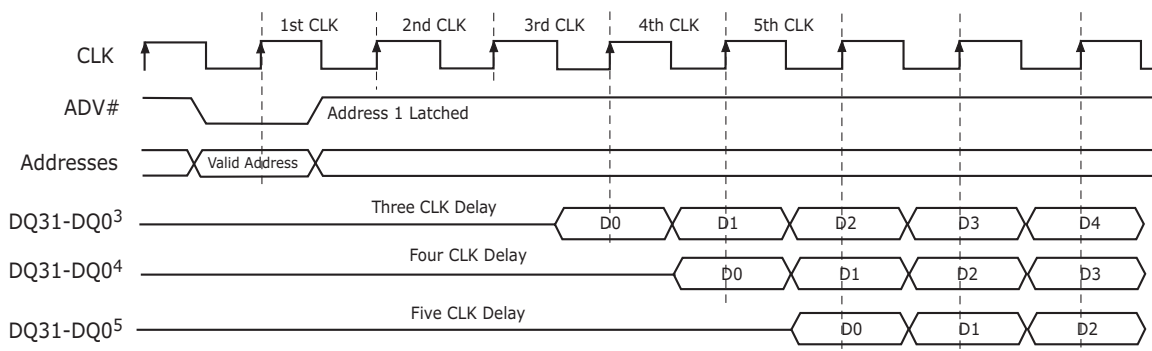

**Notes:**

1. Burst access starts with a rising CLK edge and when ADV# is active.
2. Configurations register 6 is always set to 1 (CR6 = 1). Burst starts and data outputs on the rising CLK edge.
3. CR [13-10] = 1 or three clock cycles
4. CR [13-10] = 2 or four clock cycles
5. CR [13-10] = 3 or five clock cycles

**Figure 3. Initial Burst Delay Control**

### Burst CLK Edge Data Delivery

The device delivers data on the rising of CLK. Bit 6 in the Control Register (CR6) is set to 1, and is the default configuration.

### Burst Data Hold Control

The device is capable of holding data for one CLKs. The default configuration is to hold data for one CLK and is the only valid state.



### Asserting RESET# During A Burst Access

If RESET# is asserted low during a burst access, the burst access is immediately terminated and the device defaults back to asynchronous read mode. See [Hardware Reset \(RESET#\)](#) on page 71 for more information on the RESET# function.

## Configuration Register

The device contains a Configuration Register for configuring read accesses. The Configuration Register is accessed by the Configuration Register Read and the Configuration Register Write commands. The Configuration Register does not occupy any addressable memory location, but rather, is accessed by the Configuration Register commands. The Configuration Register is readable any time, however, writing the Configuration Register is restricted to times when the Embedded Algorithm™ is not active. If the user attempts to write the Configuration Register while the Embedded Algorithm™ is active, the write operation is ignored and the contents of the Configuration Register remain unchanged.

The Configuration Register is a 16 bit data field which is accessed by DQ15–DQ0. During a read operation, DQ31–DQ16 returns all zeroes. [Table 33](#) shows the Configuration Register. Also, Configuration Register reads operate the same as Autoselect command reads. When the command is issued, the bank address is latched along with the command. Reads operations to the bank that was specified during the Configuration Register read command return Configuration Register contents. Read operations to the other bank return flash memory data. Either bank address is permitted when writing the Configuration Register read command.

**Table 33. Configuration Register Definitions**

CR15	CR14	CR13	CR12	CR11	CR10	CR9	CR8
<b>RM</b>	<b>ASD</b>	<b>IAD3</b>	<b>IAD2</b>	<b>IAD1</b>	<b>IAD0</b>	<b>DOC</b>	<b>WC</b>
CR7	CR6	CR5	CR4	CR3	CR2	CR1	CR0
<b>BS</b>	<b>CC</b>	<b>Reserved</b>	<b>Reserved</b>	<b>Reserved</b>	<b>BL2</b>	<b>BL1</b>	<b>BLO</b>

<b>Configuration Register</b>								
<p><b>CR15 = Read Mode (RM)</b>            0 = Synchronous Burst Reads Enabled            1 = Asynchronous Reads Enabled (Default)</p>								
<p><b>CR14 = Reserved for Future Enhancements</b>            0 = ASM enable            1 = ASM disable</p>								
<p><b>CR13–CR10 = Automatic Sleep Mode Disable</b>  <i>Speed Options 40, 56, and 66 MHz:</i></p> <table border="0"> <tr> <td>0000 = 2 CLK cycle initial burst access delay</td> <td>0100 = 6 CLK cycle initial burst access delay</td> </tr> <tr> <td>0001 = 3 CLK cycle initial burst access delay</td> <td>0101 = 7 CLK cycle initial burst access delay</td> </tr> <tr> <td>0010 = 4 CLK cycle initial burst access delay</td> <td>0110 = 8 CLK cycle initial burst access delay</td> </tr> <tr> <td>0011 = 5 CLK cycle initial burst access delay</td> <td>0111 = 9 CLK cycle initial burst access delay—Default</td> </tr> </table>	0000 = 2 CLK cycle initial burst access delay	0100 = 6 CLK cycle initial burst access delay	0001 = 3 CLK cycle initial burst access delay	0101 = 7 CLK cycle initial burst access delay	0010 = 4 CLK cycle initial burst access delay	0110 = 8 CLK cycle initial burst access delay	0011 = 5 CLK cycle initial burst access delay	0111 = 9 CLK cycle initial burst access delay—Default
0000 = 2 CLK cycle initial burst access delay	0100 = 6 CLK cycle initial burst access delay							
0001 = 3 CLK cycle initial burst access delay	0101 = 7 CLK cycle initial burst access delay							
0010 = 4 CLK cycle initial burst access delay	0110 = 8 CLK cycle initial burst access delay							
0011 = 5 CLK cycle initial burst access delay	0111 = 9 CLK cycle initial burst access delay—Default							
<p><b>CR9 = Data Output Configuration (DOC)</b>            0 = Hold Data for 1-CLK cycle—Default            1 = Reserved</p>								
<p><b>CR8 = IND/WAIT# Configuration (WC)</b>            0 = IND/WAIT# Asserted During Delay—Default            1 = IND/WAIT# Asserted One Data Cycle Before Delay</p>								
<p><b>CR7 = Burst Sequence (BS)</b>            0 = Reserved            1 = Linear Burst Order—Default</p>								
<p><b>CR6 = Clock Configuration (CC)</b>            0 = Reserved            1 = Burst Starts and Data Output on Rising Clock Edge—Default</p>								
<p><b>CR5–CR3 = Reserved For Future Enhancements (R)</b>            These bits are reserved for future use. Set these bits to 0.</p>								
<p><b>CR2–CR0 = Burst Length (BL2–BLO)</b></p> <table border="0"> <tr> <td>000 = Reserved, burst accesses disabled (asynchronous reads only)</td> </tr> <tr> <td>001 = 64 bit (8-byte) Burst Data Transfer - x32 Linear</td> </tr> <tr> <td>010 = 128 bit (16-byte) Burst Data Transfer - x32 Linear</td> </tr> <tr> <td>011 = 256 bit (32-byte) Burst Data Transfer - x32 Linear (device default)</td> </tr> <tr> <td>100 = Reserved, burst accesses disabled (asynchronous reads only)</td> </tr> <tr> <td>101 = Reserved, burst accesses disabled (asynchronous reads only)</td> </tr> <tr> <td>110 = Reserved, burst accesses disabled (asynchronous reads only)</td> </tr> </table>	000 = Reserved, burst accesses disabled (asynchronous reads only)	001 = 64 bit (8-byte) Burst Data Transfer - x32 Linear	010 = 128 bit (16-byte) Burst Data Transfer - x32 Linear	011 = 256 bit (32-byte) Burst Data Transfer - x32 Linear (device default)	100 = Reserved, burst accesses disabled (asynchronous reads only)	101 = Reserved, burst accesses disabled (asynchronous reads only)	110 = Reserved, burst accesses disabled (asynchronous reads only)	
000 = Reserved, burst accesses disabled (asynchronous reads only)								
001 = 64 bit (8-byte) Burst Data Transfer - x32 Linear								
010 = 128 bit (16-byte) Burst Data Transfer - x32 Linear								
011 = 256 bit (32-byte) Burst Data Transfer - x32 Linear (device default)								
100 = Reserved, burst accesses disabled (asynchronous reads only)								
101 = Reserved, burst accesses disabled (asynchronous reads only)								
110 = Reserved, burst accesses disabled (asynchronous reads only)								

**Table 34. Configuration Register After Device Reset**

CR15	CR14	CR13	CR12	CR11	CR10	CR9	CR8
<b>RM</b>	<b>Reserve</b>	<b>IAD3</b>	<b>IAD2</b>	<b>IAD1</b>	<b>IAD0</b>	<b>DOC</b>	<b>WC</b>
1	0	0	1	1	1	0	0
CR7	CR6	CR5	CR4	CR3	CR2	CR1	CR0
<b>BS</b>	<b>CC</b>	<b>Reserve</b>	<b>Reserve</b>	<b>Reserve</b>	<b>BL2</b>	<b>BL1</b>	<b>BLO</b>
1	1	0	0	0	1	0	0

## Initial Access Delay Configuration

The frequency configuration informs the device of the number of clocks that must elapse after ADV# is driven active before data is available. This value is determined by the input clock frequency.

## Sector Protection

The device features several levels of sector protection, which can disable both the program and erase operations in certain sectors or sector groups

### Sector and Sector Groups

The distinction between sectors and sector groups is fundamental to sector protection. Sectors are individual sectors that can be individually sector protected/unprotected. These are the outermost 4 Kword boot sectors, that is, SA0 to SA7 and SA70 to SA77. See [Table 35 on page 35](#), [Table 23 on page 19](#), [Table 24 on page 20](#), [Table 25 on page 21](#), and [Table 26 on page 22](#).

Sector groups are a collection of three or four adjacent 32 kword sectors. For example, sector group SG8 is comprised of sector SA8 to SA10. When any sector in a sector group is protected/unprotected, every sector in that group is protection/unprotected. See [Table 35](#), [Table 23](#), [Table 24](#), [Table 25](#), and [Table 26](#).

### Persistent Sector Protection

A command sector protection method that replaces the old 12 V controlled protection method.

### Password Sector Protection

A highly sophisticated protection method that requires a password before changes to certain sectors or sector groups are permitted.

### WP# Hardware Protection

A write protect pin that can prevent program or erase to the two outermost 8 Kbytes sectors in the 75% bank.

All parts default to operate in the Persistent Sector Protection mode. The customer must then choose if the Persistent or Password Protection method is most desirable. There are two one-time programmable non-volatile bits that define which sector protection method is used. If the customer decides to continue using the Persistent Sector Protection method, they must set the **Persistent Sector Protection Mode Locking Bit**. This permanently sets the part to operate only using Persistent Sector Protection. If the customer decides to use the password method, they must set the **Password Mode Locking Bit**. This permanently sets the part to operate only using password sector protection.

It is important to remember that setting either the **Persistent Sector Protection Mode Locking Bit** or the **Password Mode Locking Bit** permanently selects the protection mode. It is not possible to switch between the two methods once a locking bit is set. **It is important that one mode is explicitly selected when the device is first programmed, rather than relying on**

**the default mode alone.** This is so that it is not possible for a system program or virus to later set the Password Mode Locking Bit, which would cause an unexpected shift from the default Persistent Sector Protection Mode into the Password Protection Mode.

The WP# Hardware Protection feature is always available, independent of the software managed protection method chosen.

## Persistent Sector Protection

The Persistent Sector Protection method replaces the old 12 V controlled protection method while at the same time enhancing flexibility by providing three different sector protection states:

- **Persistently Locked**—A sector is protected and cannot be changed.
- **Dynamically Locked**—The sector is protected and can be changed by a simple command
- **Unlocked**—The sector is unprotected and can be changed by a simple command

In order to achieve these states, three types of *bits* are going to be used:

### Persistent Protection Bit (PPB)

A single Persistent (non-volatile) Protection Bit is assigned to a maximum of four sectors (see the sector address tables for specific sector protection groupings). All 8 Kbyte boot-block sectors have individual sector Persistent Protection Bits (PPBs) for greater flexibility. Each PPB is individually modifiable through the **PPB Write Command**.

*Note: If a PPB requires erasure, all of the sector PPBs must first be preprogrammed prior to PPB erasing. All PPBs erase in parallel, unlike programming where individual PPBs are programmable. It is the responsibility of the user to perform the preprogramming operation. Otherwise, an already erased sector PPBs has the potential of being over-erased. There is no hardware mechanism to prevent sector PPBs over-erasure.*

### Persistent Protection Bit Lock (PPB Lock)

A global volatile bit. When set to 1, the PPBs cannot be changed. When cleared (0), the PPBs are changeable. There is only one PPB Lock bit per device. The PPB Lock is cleared after power-up or hardware reset. There is no command sequence to unlock the PPB Lock.

### Dynamic Protection Bit (DYB)

A volatile protection bit is assigned for each sector. After power-up or hardware reset, the contents of all DYBs is 0. Each DYB is individually modifiable through the DYB Write Command.

When the parts are first shipped, the PPBs are cleared, the DYBs are cleared, and PPB Lock is defaulted to power up in the cleared state – meaning the PPBs are changeable.

When the device is first powered on the DYBs power up cleared (sectors not protected). The Protection State for each sector is determined by the logical OR of the PPB and the DYB related to that sector. For the sectors that have the PPBs cleared, the DYBs control whether or not the sector is protected or unprotected. By issuing the DYB Write command sequences, the DYBs is set or cleared, thus placing each sector in the protected or unprotected state. These are the so-called **Dynamic Locked or Unlocked** states. They are called dynamic states because it is very easy to switch back and forth between the protected and unprotected conditions. This allows software to easily protect sectors against inadvertent changes yet does not prevent the easy removal of protection when changes are needed. The DYBs maybe set or cleared as often as needed.

The PPBs allow for a more static, and difficult to change, level of protection. The PPBs retain state across power cycles because they are Non-Volatile. Individual PPBs are set with a command but must all be cleared as a group through a complex sequence of program and erasing commands. The PPBs are limited to 100 erase cycles.

The PPB Lock bit adds an additional level of protection. Once all PPBs are programmed to the desired settings, the PPB Lock may be set to 1. Setting the PPB Lock disables all program and erase

commands to the Non-Volatile PPBs. In effect, the PPB Lock Bit locks the PPBs into the current state. The only way to clear the PPB Lock is to go through a power cycle. System boot code can determine if any changes to the PPB are needed e.g. to allow new system code to be downloaded. If no changes are needed then the boot code can set the PPB Lock to disable any further changes to the PPBs during system operation.

The WP# write protect pin adds a final level of hardware protection to the two outermost 8 Kbytes sectors in the 75% bank. When this pin is low it is not possible to change the contents of these two sectors.

It is possible to have sectors that have been persistently locked, and sectors that are left in the dynamic state. The sectors in the dynamic state are all unprotected. If there is a need to protect some of them, a simple DYB Write command sequence is all that is necessary. The DYB write command for the dynamic sectors switch the DYBs to signify protected and unprotected, respectively. If there is a need to change the status of the persistently locked sectors, a few more steps are required. First, the PPB Lock bit must be disabled by either putting the device through a power-cycle, or hardware reset. The PPBs can then be changed to reflect the desired settings. Setting the PPB lock bit once again, locks the PPBs and the device operates normally again.

**Note:** To achieve the best protection, it's recommended to execute the PPB lock bit set command early in the boot code, and protect the boot code by holding  $WP\# = V_{IL}$ .

**Table 35. Sector Protection Schemes**

DYB	PPB	PPB Lock	Sector State
0	0	0	Unprotected—PPB and DYB are changeable
0	0	1	Unprotected—PPB not changeable, DYB is changeable
0	1	0	Protected—PPB and DYB are changeable
1	0	0	
1	1	0	Protected—PPB not changeable, DYB is changeable
0	1	1	
1	0	1	
1	1	1	

Table 35 contains all possible combinations of the DYB, PPB, and PPB lock relating to the status of the sector.

In summary, if the PPB is set, and the PPB lock is set, the sector is protected and the protection can not be removed until the next power cycle clears the PPB lock. If the PPB is cleared, the sector can be dynamically locked or unlocked. The DYB then controls whether or not the sector is protected or unprotected.

If the user attempts to program or erase a protected sector, the device ignores the command and returns to read mode. A program command to a protected sector enables status polling for approximately 1  $\mu$ s before the device returns to read mode without having modified the contents of the protected sector. An erase command to a protected sector enables status polling for approximately 50  $\mu$ s after which the device returns to read mode without having erased the protected sector.

The programming of the DYB, PPB, and PPB lock for a given sector can be verified by writing a DYB/PPB/PPB lock verify command to the device.

## Persistent Sector Protection Mode Locking Bit

Like the password mode locking bit, a Persistent Sector Protection mode locking bit exists to guarantee that the device remain in software sector protection. Once set, the Persistent Sector Protection locking bit prevents programming of the password protection mode locking bit. This guarantees that an unauthorized user could not place the device in password protection mode.

## Password Protection Mode

The Password Sector Protection Mode method allows an even higher level of security than the Persistent Sector Protection Mode. There are two main differences between the Persistent Sector Protection and the Password Sector Protection Mode:

- When the device is first powered on, or comes out of a reset cycle, the PPB Lock bit set to the **locked state**, rather than cleared to the unlocked state.
- The only means to clear the PPB Lock bit is by writing a unique **64-bit Password** to the device.

The Password Sector Protection method is otherwise identical to the Persistent Sector Protection method.

A 64-bit password is the only additional tool utilized in this method.

The password is stored in a **one-time programmable (OTP)** region of the flash memory. Once the Password Mode Locking Bit is set, the password is permanently set with no means to read, program, or erase it. The password is used to clear the PPB Lock bit. The Password Unlock command must be written to the flash, along with a password. The flash device internally compares the given password with the pre-programmed password. If they match, the PPB Lock bit is cleared, and the PPBs can be altered. If they do not match, the flash device does nothing. There is a built-in 2  $\mu$ s delay for each *password check*. This delay is intended to stop any efforts to run a program that tries all possible combinations in order to crack the password.

## Password and Password Mode Locking Bit

In order to select the Password sector protection scheme, the customer must first program the password. One method of choosing a password would be to correlate it to the unique Electronic Serial Number (ESN) of the particular flash device. Another method could generate a database where all the passwords are stored, each of which correlates to a serial number on the device. Each ESN is different for every flash device; therefore each password should be different for every flash device. While programming in the password region, the customer may perform Password Verify operations.

Once the desired password is programmed in, the customer must then set the Password Mode Locking Bit. This operation achieves two objectives:

- 1) It permanently sets the device to operate using the Password Protection Mode. It is not possible to reverse this function.
- 2) It also disables *all further commands* to the password region. All program, and read operations are ignored.

Both of these objectives are important, and if not carefully considered, may lead to unrecoverable errors. The user must be sure that the Password Protection method is desired when setting the Password Mode Locking Bit. More importantly, the user must be sure that the password is correct when the Password Mode Locking Bit is set. Due to the fact that read operations are disabled, there is no means to verify what the password is afterwards. If the password is lost after setting the Password Mode Locking Bit, there is no way to clear the PPB Lock bit.

The Password Mode Locking Bit, once set, prevents reading the 64-bit password on the DQ bus and further password programming. The Password Mode Locking Bit is not erasable. Once Password Mode Locking Bit is programmed, the Persistent Sector Protection Locking Bit is disabled from programming, guaranteeing that no changes to the protection scheme are allowed.

### 64-bit Password

The 64-bit Password is located in its own memory space and is accessible through the use of the Password Program and Verify commands (see [Password Verify Command](#)). The password function

works in conjunction with the Password Mode Locking Bit, which when set, prevents the Password Verify command from reading the contents of the password on the pins of the device.

## Write Protect (WP#)

The device features a hardware protection option using a write protect pin that prevents programming or erasing, regardless of the state of the sector's Persistent or Dynamic Protection Bits. The WP# pin is associated with the two outermost 8Kbytes sectors in the 75% bank. The WP# pin has no effect on any other sector. When WP# is taken to  $V_{IL}$ , programming and erase operations of the two outermost 8 Kbytes sectors in the 75% bank are disabled. By taking WP# back to  $V_{IH}$ , the two outermost 8 Kbytes sectors are enabled for program and erase operations, depending upon the status of the individual sector Persistent or Dynamic Protection Bits. If either of the two outermost sectors Persistent or Dynamic Protection Bits are programmed, program or erase operations are inhibited. If the sector Persistent or Dynamic Protection Bits are both erased, the two sectors are available for programming or erasing as long as WP# remains at  $V_{IH}$ . The user must hold the WP# pin at either  $V_{IH}$  or  $V_{IL}$  during the entire program or erase operation of the two outermost sectors in the 75% bank.

## Secured Silicon OTP Sector and Simultaneous Operation

The Secured Silicon Sector is 256 Kbytes and is located in the Small Bank. For S29CD016G and S29CD032G devices. Spansion programs and permanently locks the Secured Silicon sector with Unique device identification. Please contact your sales representative for the Electronic Marking information.

Since the Secured Silicon is permanent protected by Spansion, during Simultaneous Operation, the Secured Silicon sector cannot be erased or reprogrammed.

## Persistent Protection Bit Lock

The Persistent Protection Bit (PPB) Lock is a volatile bit that reflects the state of the Password Mode Locking Bit after power-up reset. If the Password Mode Locking Bit is set, which indicates the device is in Password Protection Mode, the PPB Lock Bit is also set after a hardware reset (RESET# asserted) or a power-up reset. The ONLY means for clearing the PPB Lock Bit in Password Protection Mode is to issue the Password Unlock command. Successful execution of the Password Unlock command clears the PPB Lock Bit, allowing for sector PPBs modifications. Asserting RESET#, taking the device through a power-on reset, or issuing the PPB Lock Bit Set command sets the PPB Lock Bit back to a 1.

If the Password Mode Locking Bit is not set, indicating Persistent Sector Protection Mode, the PPB Lock Bit is cleared after power-up or hardware reset. The PPB Lock Bit is set by issuing the PPB Lock Bit Set command. Once set the only means for clearing the PPB Lock Bit is by issuing a hardware or power-up reset. The Password Unlock command is ignored in Persistent Sector Protection Mode.

## Hardware Data Protection

The command sequence requirement of unlock cycles for programming or erasing provides data protection against inadvertent writes. In addition, the following hardware data protection measures prevent accidental erasure or programming, which might otherwise be caused by spurious system level signals during  $V_{CC}$  power-up and power-down transitions, or from system noise.

### Low $V_{CC}$ Write Inhibit

When  $V_{CC}$  is less than  $V_{LKO}$ , the device does not accept any write cycles. This protects data during  $V_{CC}$  power-up and power-down. The command register and all internal erase/program circuits are disabled, and the device resets. Subsequent writes are ignored until  $V_{CC}$  is greater than  $V_{LKO}$ . The

system must provide the proper signals to the control pins to prevent unintentional writes when  $V_{CC}$  is greater than  $V_{LKO}$ .

#### **Write Pulse *Glitch* Protection**

Noise pulses of less than 5 ns (typical) on OE#, CE#, or WE# do not initiate a write cycle.

#### **Logical Inhibit**

Write cycles are inhibited by holding any one of OE# =  $V_{IL}$ , CE# =  $V_{IH}$ , or WE# =  $V_{IH}$ . To initiate a write cycle, CE# and WE# must be a logical zero ( $V_{IL}$ ) while OE# is a logical one ( $V_{IH}$ ).

#### **Power-Up Write Inhibit**

If WE# = CE# =  $V_{IL}$  and OE# =  $V_{IH}$  during power-up, the device does not accept commands on the rising edge of WE#. The internal state machine is automatically reset to reading array data on power-up.

#### **$V_{CC}$ and $V_{IO}$ Power-up And Power-down Sequencing**

The device imposes no restrictions on  $V_{CC}$  and  $V_{IO}$  power-up or power-down sequencing. Asserting RESET# to  $V_{IL}$  is required during the entire  $V_{CC}$  and  $V_{IO}$  power sequence until the respective supplies reach the operating voltages. Once,  $V_{CC}$  and  $V_{IO}$  attain the operating voltages, de-assertion of RESET# to  $V_{IH}$  is permitted.



## Common Flash Memory Interface (CFI)

The Common Flash Interface (CFI) specification outlines device and host system software interrogation handshake, which allows specific vendor-specified software algorithms to be used for entire families of devices. Software support can then be device-independent, JEDEC ID-independent, and forward- and backward-compatible for the specified flash device families. Flash vendors can standardize existing interfaces for long-term compatibility.

This device enters the CFI Query mode when the system writes the CFI Query command, 98h, to address 55h in word mode (or address AAh in byte mode), any time the device is ready to read array data. The system can read CFI information at the addresses given in Tables 13–16. To terminate reading CFI data, the system must write the reset command.

The system can also write the CFI query command when the device is in the autoselect mode. The device enters the CFI query mode, and the system can read CFI data at the addresses given in Tables 13–16. The system must write the reset command to return the device to the autoselect mode.

For further information, please refer to the CFI Specification and CFI Publication 100, available via the World Wide Web at <http://www.spansion.com>. Alternatively, contact an AMD representative for copies of these documents.

**Table 36. CFI Query Identification String**

Addresses	Data	Description
10h 11h 12h	0051h 0052h 0059h	Query Unique ASCII string <i>QRY</i>
13h 14h	0002h 0000h	Primary OEM Command Set
15h 16h	0040h 0000h	Address for Primary Extended Table
17h 18h	0000h 0000h	Alternate OEM Command Set (00h = none exists)
19h 1Ah	0000h 0000h	Address for Alternate OEM Extended Table (00h = none exists)

**Table 37. CFI System Interface String**

Addresses	Data	Description
1Bh	0023h	$V_{CC}$ Min. (write/erase) DQ7–DQ4: volts, DQ3–DQ0: 100 millivolt
1Ch	0027h	$V_{CC}$ Max. (write/erase) DQ7–DQ4: volts, DQ3–DQ0: 100 millivolt
1Dh	0000h	$V_{PP}$ Min. voltage (00h = no $V_{PP}$ pin present)
1Eh	0000h	$V_{PP}$ Max. voltage (00h = no $V_{PP}$ pin present)
1Fh	0004h	Typical timeout per single word/doubleword program $2^n$ $\mu$ s
20h	0000h	Typical timeout for Min. size buffer program $2^n$ $\mu$ s (00h = not supported)
21h	0009h	Typical timeout per individual block erase $2^n$ ms
22h	0000h	Typical timeout for full chip erase $2^n$ ms (00h = not supported)
23h	0005h	Max. timeout for word/doubleword program $2^n$ times typical
24h	0000h	Max. timeout for buffer write $2^n$ times typical
25h	0007h	Max. timeout per individual block erase $2^n$ times typical
26h	0000h	Max. timeout for full chip erase $2^n$ times typical (00h = not supported)

**Table 38. Device Geometry Definition**

Addresses	Data	Description
27h	0016h	Device Size = 2 <sup>n</sup> byte
28h 29h	0005h 0000h	Flash Device Interface description (for complete description, please refer to CFI publication 100) 0000 = x8-only asynchronous interface 0001 = x16-only asynchronous interface 0002 = supports x8 and x16 via BYTE# with asynchronous interface 0003 = x 32-only asynchronous interface 0005 = supports x16 and x32 via WORD# with asynchronous interface
2Ah 2Bh	0000h 0000h	Max. number of byte in multi-byte program = 2 <sup>n</sup> (00h = not supported)
2Ch	0003h	Number of Erase Block Regions within device
2Dh 2Eh 2Fh 30h	0007h 0000h 0020h 0000h	Erase Block Region 1 Information (refer to the CFI specification or CFI publication 100)
31h 32h 33h 34h	003Dh* 0000h 0000h 0001h	Erase Block Region 2 Information (refer to the CFI specification or CFI publication 100)
35h 36h 37h 38h	0007h 0000h 0020h 0000h	Erase Block Region 3 Information (refer to the CFI specification or CFI publication 100)
39h 3Ah 3Bh 3Ch	0000h 0000h 0000h 0000h	Erase Block Region 4 Information (refer to the CFI specification or CFI publication 100)

\* On 16 Mb device, data at address 31h is 1Dh.

Table 39. CFI Primary Vendor-Specific Extended Query

Addresses	Data	Description
40h 41h 42h	0050h 0052h 0049h	Query-unique ASCII string <i>PR1</i>
43h	0031h	Major version number, ASCII (reflects modifications to the silicon)
44h	0033h	Minor version number, ASCII (reflects modifications to the CFI table)
45h	0004h	Address Sensitive Unlock (DQ1, DQ0) 00 = Required, 01 = Not Required Silicon Revision Number (DQ5–DQ2) 0000 = CS49 0001 = CS59 0010 = CS99 0011 = CS69 0100 = CS119
46h	0002h	Erase Suspend (1 byte) 00 = Not Supported 01 = To Read Only 02 = To Read and Write
47h	0001h	Sector Protect (1 byte) 00 = Not Supported, X = Number of sectors in per group
48h	0000h	Temporary Sector Unprotect 00h = Not Supported, 01h = Supported
49h	0006h	Sector Protect/Unprotect scheme (1 byte) 01 = 29F040 mode, 02 = 29F016 mode 03 = 29F400 mode, 04 = 29LV800 mode 05 = 29BDS640 mode (Software Command Locking) 06 = BDD160 mode (New Sector Protect) 07 = 29LV800 + PDL128 (New Sector Protect) mode
4Ah	0037h	Simultaneous Read/Write (1 byte) 00h = Not Supported, X = Number of sectors in all banks except Bank 1
4Bh	0001h	Burst Mode Type 00h = Not Supported, 01h = Supported
4Ch	0000h	Page Mode Type 00h = Not Supported, 01h = 4 Word Page, 02h = 8 Word Page
4Dh	00B5h	ACC (Acceleration) Supply Minimum 00h = Not Supported (DQ7–DQ4: volt in hex, DQ3–DQ0: 100 mV in BCD)
4Eh	00C5h	ACC (Acceleration) Supply Maximum 00h = Not Supported, (DQ7–DQ4: volt in hex, DQ3–DQ0: 100 mV in BCD)
4Fh	0001h	Top/Bottom Boot Sector Flag (1 byte) 00h = Uniform device, no WP# control, 01h = 8 x 8 Kb sectors at top and bottom with WP# control 02h = Bottom boot device 03h = Top boot device 04h = Uniform, Bottom WP# Protect 05h = Uniform, Top WP# Protect If the number of erase block regions = 1, then ignore this field
50h	0001h	Program Suspend 00 = Not Supported 01 = Supported
51h	0000h	Write Buffer Size $2^{(N+1)}$ word(s)
57h	0002h	Bank Organization (1 byte) 00 = If data at 4Ah is zero XX = Number of banks
58h	0017h	Bank 1 Region Information (1 byte) XX = Number of Sectors in Bank 1
59h	0037h	Bank 2 Region Information (1 byte) XX = Number of Sectors in Bank 2
5Ah	0000h	Bank 3 Region Information (1 byte) XX = Number of Sectors in Bank 3
5Bh	0000h	Bank 4 Region Information (1 byte) XX = Number of Sectors in Bank 4

## Command Definitions

Writing specific address and data commands or sequences into the command register initiates device operations. [Table 41 on page 54](#) and [Table 42 on page 55](#) define the valid register command sequences. Writing **incorrect address and data values** or writing them in the **improper sequence** resets the device to reading array data.

All addresses are latched on the falling edge of WE# or CE#, whichever happens later. All data is latched on the rising edge of WE# or CE#, whichever happens first. See [AC Characteristics on page 67](#) for timing diagrams.

### Reading Array Data in Non-burst Mode

The device is automatically set to reading array data after device power-up. No commands are required to retrieve data. The device is also ready to read array data after completing an Embedded Program or Embedded Erase algorithm.

After the device accepts an Erase Suspend command, the device enters the Erase Suspend mode. The system can read array data using the standard read timings, except that if it reads at an address within erase-suspended sectors, the device outputs status data. After completing a programming operation in the Erase Suspend mode, the system may once again read array data with the same exception. See [Sector Erase and Program Suspend Command on page 47](#) for more information on this mode.

The system *must* issue the reset command to re-enable the device for reading array data if DQ5 goes high, or while in the autoselect mode. See [PPB Lock Bit Set Command on page 51](#).

[Asynchronous Read Operation \(Non-Burst\) on page 27](#) for more information. See [Sector Erase and Program Resume Command on page 49](#) for more information on this mode.

### Reading Array Data in Burst Mode

The device is capable of very fast Burst mode read operations. The configuration register sets the read configuration, burst order, frequency configuration, and burst length.

Upon power on, the device defaults to the asynchronous mode. In this mode, CLK, and ADV# are ignored. The device operates like a conventional Flash device. Data is available  $t_{ACC}/t_{CE}$  nanoseconds after address becomes stable, CE# become asserted. The device enters the burst mode by enabling synchronous burst reads in the configuration register. The device exits burst mode by disabling synchronous burst reads in the configuration register. (See [Command Definitions on page 42](#)). The RESET# command does not terminate the Burst mode. System reset (power on reset) terminates the Burst mode.

The device has the regular control pins, i.e. Chip Enable (CE#), Write Enable (WE#), and Output Enable (OE#) to control normal read and write operations. Moreover, three additional control pins were added to allow easy interface with minimal glue logic to a wide range of microprocessors / microcontrollers for high performance Burst read capability. These additional pins are Address Valid (ADV#) and Clock (CLK). CE#, OE#, and WE# are asynchronous (relative to CLK). The Burst mode read operation is a synchronous operation tied to the edge of the clock. The microprocessor / microcontroller supplies only the initial address, all subsequent addresses are automatically generated by the device with a timing defined by the Configuration Register definition. The Burst read cycle consists of an address phase and a corresponding data phase.

During the address phase, the Address Valid (ADV#) pin is asserted (taken Low) for one clock period. Together with the edge of the CLK, the starting burst address is loaded into the internal Burst Address Counter. The internal Burst Address Counter can be configured to either 2, 4, and 8 double word linear burst, with or without wrap around. See [Initial Access Delay Configuration on page 33](#).

During the data phase, the first burst data is available after the initial access time delay defined in the Configuration Register. For subsequent burst data, every rising (or falling) edge of the CLK triggers the output data with the burst output delay and sequence defined in the Configuration Register.

[Table 41 on page 54](#) and [Table 42 on page 55](#) show all the commands executed by the device. The device automatically powers up in the read/reset state. It is not necessary to issue a read/reset command after power-up or hardware reset.

## Read/Reset Command

After power-up or hardware reset, the device automatically enter the read state. It is not necessary to issue the reset command after power-up or hardware reset. Standard microprocessor cycles retrieve array data, however, after power-up, only asynchronous accesses are permitted since the Configuration Register is at its reset state with burst accesses disabled.

The Reset command is executed when the user needs to exit any of the other user command sequences (such as autoselect, program, chip erase, etc.) to return to reading array data. There is no latency between executing the Reset command and reading array data.

The Reset command does not disable the Secured Silicon sector if it is enabled. This function is only accomplished by issuing the Secured Silicon Sector Exit command.

## Autoselect Command

Flash memories are intended for use in applications where the local CPU alters memory contents. As such, manufacturer and device codes must be accessible while the device resides in the target system. PROM programmers typically access the signature codes by raising A9 to V<sub>ID</sub>. However, multiplexing high voltage onto the address lines is not generally desired system design practice.

The device contains an Autoselect Command operation to supplement traditional PROM programming methodology. The operation is initiated by writing the Autoselect command sequence into the command register. The bank address (BA) is latched during the autoselect command sequence write operation to distinguish which bank the Autoselect command references. Reading the other bank after the Autoselect command is written results in reading array data from the other bank and the specified address. Following the command write, a read cycle from address (BA)XX00h retrieves the manufacturer code of (BA)XX01h. Three sequential read cycles at addresses (BA) XX01h, (BA) XX0Eh, and (BA) XX0Fh read the three-byte device ID (see [Table 41](#)).

(The Autoselect Command requires the user to execute the Read/Reset command to return the device back to reading the array contents.)

## Program Command Sequence

Programming is a four-bus-cycle operation. The program command sequence is initiated by writing two unlock write cycles, followed by the program set-up command. The program address and data are written next, which in turn initiate the Embedded Program algorithm. The system is *not* required to provide further controls or timings. The device automatically generates the program pulses and verifies the programmed cell margin. [Table 41 on page 54](#) and [Table 42 on page 55](#) show the address and data requirements for the program command sequence.

During the Embedded Program algorithm, the system can determine the status of the program operation by using DQ7, DQ6, or RY/BY#. (See [Write Operation Status on page 56](#) for information on these status bits.) When the Embedded Program algorithm is complete, the device returns to reading array data and addresses are no longer latched. Note that an address change is required to begin read valid array data.

Except for Program Suspend, any commands written to the device during the Embedded Program Algorithm are ignored. Note that a **hardware reset** immediately terminates the programming

operation. The command sequence should be reinitiated once that bank returns to reading array data, to ensure data integrity.

Programming is allowed in any sequence and across sector boundaries. **A bit cannot be programmed from a 0 back to a 1.** Attempting to do so may halt the operation and set DQ5 to 1, or cause the Data# Polling algorithm to indicate the operation was successful. However, a succeeding read shows that the data is still 0. Only erase operations can convert a 0 to a 1.

## Accelerated Program Command

The Accelerated Chip Program mode is designed to improve the Word or Double Word programming speed. Improving the programming speed is accomplished by using the ACC pin to supply both the wordline voltage and the bitline current instead of using the V<sub>PP</sub> pump and drain pump, which is limited to 2.5 mA. Because the external ACC pin is capable of supplying significantly large amounts of current compared to the drain pump, all 32 bits are available for programming with a single programming pulse. This is an enormous improvement over the standard 5-bit programming. If the user is able to supply an external power supply and connect it to the ACC pin, significant time savings are realized.

In order to enter the Accelerated Program mode, the ACC pin must first be taken to V<sub>HH</sub> (12 V ± 0.5 V) and followed by the one-cycle command with the program address and data to follow. The Accelerated Chip Program command is only executed when the device is in Unlock Bypass mode and during normal read/reset operating mode.

In this mode, the write protection function is bypassed unless the PPB Lock Bit = 1.

The Accelerated Program command is not permitted if the Secured Silicon sector is enabled.

## Unlock Bypass Command Sequence

The unlock bypass feature allows the system to program words to the device faster than using the standard program command sequence. The unlock bypass command sequence is initiated by first writing two unlock cycles. This is followed by a third write cycle containing the unlock bypass command, 20h. The device then enters the unlock bypass mode. A two-cycle unlock bypass program command sequence is all that is required to program in this mode. The first cycle in this sequence contains the unlock bypass program command, A0h; the second cycle contains the program address and data. Additional data is programmed in the same manner. This mode dispenses with the initial two unlock cycles required in the standard program command sequence, resulting in faster total programming time. [Table 39 on page 41](#) and [Table 41 on page 54](#) show the requirements for the command sequence.

During the unlock bypass mode, only the Unlock Bypass Program and Unlock Bypass Reset commands are valid. To exit the unlock bypass mode, the system must issue the two-cycle unlock bypass reset command sequence. The first cycle must contain the data 90h; the second cycle the data 00h. Addresses are don't care for both cycles. The device then returns to reading array data.

[Figure 4 on page 45](#) illustrates the algorithm for the program operation. See [Erase/Program Operations on page 73](#) for parameters, and to [Figure 21 on page 74](#) and [Figure 22 on page 74](#) for timing diagrams.

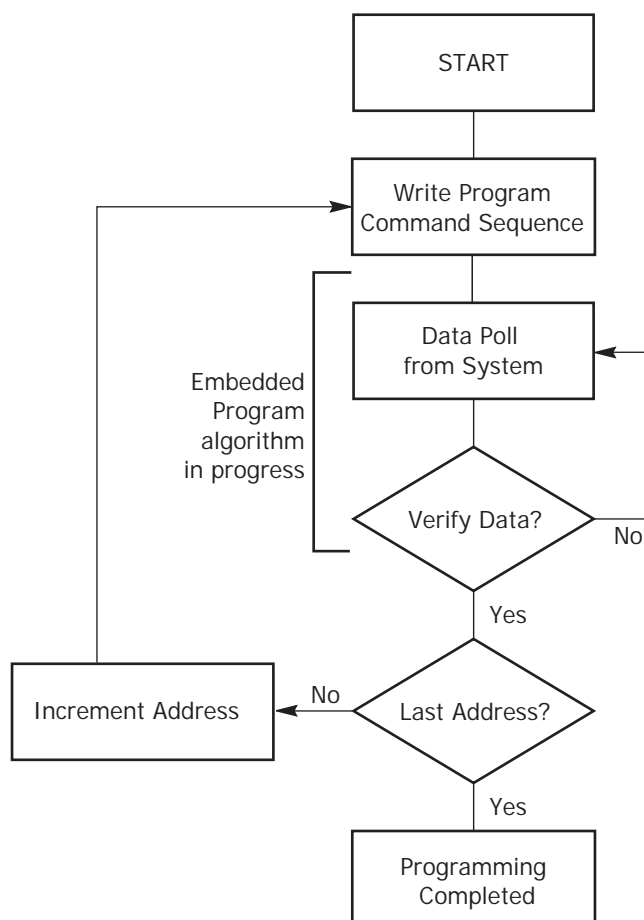

**Note:** See [Table 41](#) and [Table 42](#) for program command sequence.

**Figure 4. Program Operation**

### Unlock Bypass Entry Command

The Unlock Bypass command, once issued, is used to bypass the *unlock* sequence for program, chip erase, and CFI commands. This feature permits slow PROM programmers to significantly improve programming/erase throughput since the command sequence often requires microseconds to execute a single write operation. Therefore, once the Unlock Bypass command is issued, only the two-cycle program and erase bypass commands are required. The Unlock Bypass Command is ignored if the Secured Silicon sector is enabled. To return back to normal operation, the Unlock Bypass Reset Command must be issued.

The following four sections describe the commands that may be executed within the unlock bypass mode.

### Unlock Bypass Program Command

The Unlock Bypass Program command is a two-cycle command that consists of the actual program command (A0h) and the program address/data combination. This command does not require the two-cycle *unlock* sequence since the Unlock Bypass command was previously issued. As with the standard program command, multiple Unlock Bypass Program commands can be issued once the Unlock Bypass command is issued.

To return back to standard read operations, the Unlock Bypass Reset command must be issued.

The Unlock Bypass Program Command is ignored if the Secured Silicon sector is enabled.

### Unlock Bypass Chip Erase Command

The Unlock Bypass Chip Erase command is a 2-cycle command that consists of the erase setup command (80h) and the actual chip erase command (10h). This command does not require the two-cycle *unlock* sequence since the Unlock Bypass command was previously issued. Unlike the standard erase command, there is no Unlock Bypass Erase Suspend or Erase Resume commands.

To return back to standard read operations, the Unlock Bypass Reset command must be issued.

The Unlock Bypass Program Command is ignored if the Secured Silicon sector is enabled.

### Unlock Bypass CFI Command

The Unlock Bypass CFI command is available for PROM programmers and target systems to read the CFI codes while in Unlock Bypass mode. See [Common Flash Interface \(CFI\) Command on page 50](#) for specific CFI codes.

To return back to standard read operations, the Unlock Bypass Reset command must be issued.

The Unlock Bypass Program Command is ignored if the Secured Silicon sector is enabled.

### Unlock Bypass Reset Command

The Unlock Bypass Reset command places the device in standard read/reset operating mode. Once executed, normal read operations and user command sequences are available for execution.

The Unlock Bypass Program Command is ignored if the Secured Silicon sector is enabled.

## Chip Erase Command

The Chip Erase command is used to erase the entire flash memory contents of the chip by issuing a single command. Chip erase is a six-bus cycle operation. There are two *unlock* write cycles, followed by writing the erase *set-up* command. Two more *unlock* write cycles are followed by the chip erase command. Chip erase does not erase protected sectors.

The chip erase operation initiates the Embedded Erase algorithm, which automatically preprograms and verifies the entire memory to an all zero pattern prior to electrical erase. The system is not required to provide any controls or timings during these operations. Note that a **hardware reset** immediately terminates the programming operation. The command sequence should be reinitiated once that bank returns to reading array data, to ensure data integrity.

The Embedded Erase algorithm erase begins on the rising edge of the last WE# or CE# pulse (whichever occurs first) in the command sequence. The status of the erase operation is determined three ways:

- Data# polling of the DQ7 pin (See [DQ7: Data# Polling on page 56](#))
- Checking the status of the toggle bit DQ6 (See [DQ6: Toggle Bit I on page 58](#))
- Checking the status of the RY/BY# pin (See [RY/BY#: Ready/Busy# on page 56](#))

Once erasure begins, only the Erase Suspend command is valid. All other commands are ignored.

When the Embedded Erase algorithm is complete, the device returns to reading array data, and addresses are no longer latched. Note that an address change is required to begin read valid array data.

[Figure 5 on page 48](#) illustrates the Embedded Erase Algorithm. See the [Erase/Program Operations on page 73](#) for parameters, and [Figure 21](#) and [Figure 22](#) for timing diagrams.

## Sector Erase Command

The Sector Erase command is used to erase individual sectors or the entire flash memory contents. Sector erase is a six-bus cycle operation. There are two *unlock* write cycles, followed by writing the erase *set-up* command. Two more *unlock* write cycles are then followed by the erase command (30h). The sector address (any address location within the desired sector) is latched



on the falling edge of WE# or CE# (whichever occurs last) while the command (30h) is latched on the rising edge of WE# or CE# (whichever occurs first).

Specifying multiple sectors for erase is accomplished by writing the six bus cycle operation, as described above, and then following it by additional writes of only the last cycle of the Sector Erase command to addresses or other sectors to be erased. The time between Sector Erase command writes must be less than 80  $\mu$ s, otherwise the command is rejected. It is recommended that processor interrupts be disabled during this time to guarantee this critical timing condition. The interrupts can be re-enabled after the last Sector Erase command is written. A time-out of 80  $\mu$ s from the rising edge of the last WE# (or CE#) initiates the execution of the Sector Erase command(s). If another falling edge of the WE# (or CE#) occurs within the 80  $\mu$ s time-out window, the timer is reset. Once the 80  $\mu$ s window times out and erasure begins, only the Erase Suspend command is recognized (See [Sector Erase and Program Suspend Command on page 47](#) and [Sector Erase and Program Resume Command on page 49](#)). If that occurs, the sector erase command sequence should be reinitiated once that bank returns to reading array data, to ensure data integrity. Loading the sector erase registers may be done in any sequence and with any number of sectors.

Sector erase does not require the user to program the device prior to erase. The device automatically preprograms all memory locations, within sectors to be erased, prior to electrical erase. When erasing a sector or sectors, the remaining unselected sectors or the write protected sectors are unaffected. The system is not required to provide any controls or timings during sector erase operations. The Erase Suspend and Erase Resume commands may be written as often as required during a sector erase operation.

Automatic sector erase operations begin on the rising edge of the WE# or CE# pulse of the last sector erase command issued, and once the 80  $\mu$ s time-out window expires. The status of the sector erase operation is determined three ways:

- Data# polling of the DQ7 pin
- Checking the status of the toggle bit DQ6
- Checking the status of the RY/BY# pin

Further status of device activity during the sector erase operation is determined using toggle bit DQ2 (See [DQ2: Toggle Bit II on page 58](#)).

When the Embedded Erase algorithm is complete, the device returns to reading array data, and addresses are no longer latched. Note that an address change is required to begin read valid array data.

[Figure 5 on page 48](#) illustrates the Embedded™ Erase Algorithm, using a typical command sequence and bus operation. See the [Erase/Program Operations on page 73](#) for parameters, and to [Figure 21](#) and [Figure 22](#) for timing diagrams.

## Sector Erase and Program Suspend Command

The Sector Erase and Program Suspend command allows the user to interrupt a Sector Erase or Program operation and perform data read or programs in a sector that is not being erased or to the sector where a programming operation was initiated. This command is applicable only during the Sector Erase and Programming operation, which includes the time-out period for Sector Erase.

## Sector Erase and Program Suspend Operation Mechanics

The Sector Erase and Program Suspend command is ignored if written during the execution of the Chip Erase operation or Embedded Program Algorithm (but resets the chip if written improperly during the command sequences). Writing the Sector Erase and Program command during the Sector Erase time-out results in immediate termination of the time-out period and suspension of the erase operation. Once in Erase Suspend, the device is available for reading (note that in the

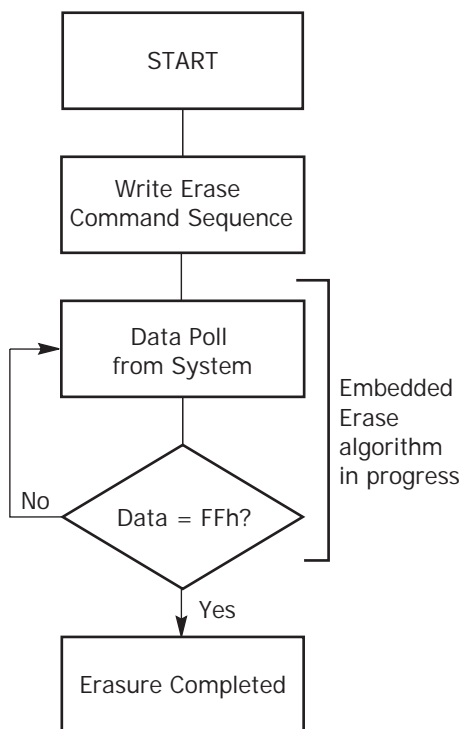

**Notes:**

- 1. See Table 41 and Table 42 for erase command sequence.
- 2. See DQ3: Sector Erase Timer for more information.

**Figure 5. Erase Operation**

Erase Suspend mode, the Reset command is not required for read operations and is ignored) or program operations in sectors not being erased. Any other command written during the Erase Suspend mode is ignored, except for the Sector Erase and Program Resume command. Writing the Erase and Program Resume command resumes the sector erase operation. The bank address of the erase suspended bank is required when writing this command

If the Sector Erase and Program Suspend command is written during a programming operation, the device suspends programming operations and allows only read operations in sectors not selected for programming. Further nesting of either erase or programming operations is not permitted. Table 40 summarizes permissible operations during Erase and Program Suspend. (A busy sector is one that is selected for programming or erasure.):

**Table 40. Allowed Operations During Erase/Program Suspend**

Sector	Program Suspend	Erase Suspend
Busy Sector	Program Resume	Erase Resume
Non-busy sectors	Read Only	Read or Program

When the Sector Erase and Program Suspend command is written during a Sector Erase operation, the chip takes between 0.1 μs and 20 μs to actually suspend the operation and go into the erase suspended read mode (pseudo-read mode), at which time the user can read or program from a sector that is not erase suspended. Reading data in this mode is the same as reading from the standard read mode, except that the data must be read from sectors that were not erase suspended.

Polling DQ6 on two immediately consecutive reads from a given address provides the system with the ability to determine if the device is in Erase or Program Suspend. Before the device enters Erase or Program Suspend, the DQ6 pin toggles between two immediately consecutive reads from the same address. After the device enters Erase suspend, DQ6 stops toggling between two im-

mediately consecutive reads to the same address. During the Sector Erase operation and also in Erase suspend mode, two immediately consecutive readings from the erase-suspended sector causes DQ2 to toggle. DQ2 does not toggle if reading from a non-busy (non-erasing) sector (stored data is read). No bits are toggled during program suspend mode. Software must keep track of the fact that the device is in a suspended mode.

After entering the erase-suspend-read mode, the system may read or program within any non-suspended sector:

- A read operation from the erase-suspended bank returns polling data during the first 8  $\mu$ s after the erase suspend command is issued; read operations thereafter return array data. Read operations from the other bank return array data with no latency.
- A program operation while in the erase suspend mode is the same as programming in the regular program mode, except that the data must be programmed to a sector that is not erase suspended. Write operation status is obtained in the same manner as a normal program operation.

## Sector Erase and Program Resume Command

The Sector Erase and Program Resume command (30h) resumes a Sector Erase or Program operation that was suspended. Any further writes of the Sector Erase and Program Resume command ignored. However, another Sector Erase and Program Suspend command can be written after the device resumes sector erase operations. Note that until a suspended program or erase operation resumes, the contents of that sector are unknown.

The Sector Erase and Program Resume Command is ignored if the Secured Silicon sector is enabled.

## Configuration Register Read Command

The Configuration Register Read command is used to verify the contents of the Configuration Register. Execution of this command is only allowed while in user mode and is not available during Unlock Bypass mode or during Security mode. The Configuration Register Read command is preceded by the standard two-cycle *unlock* sequence, followed by the Configuration Register Read command (C6h), and finally followed by performing a read operation to the bank address specified when the C6h command was written. Reading the other bank results in reading the flash memory contents. The contents of the Configuration Register are placed on DQ15–DQ0. Contents of DQ31–DQ16 are XXXXh and should be ignored. The user should execute the Read/Reset command to place the device back in standard user operation after executing the Configuration Register Read command.

The Configuration Register Read Command is fully operational if the Secured Silicon sector is enabled.

## Configuration Register Write Command

The Configuration Register Write command is used to modify the contents of the Configuration Register. Execution of this command is only allowed while in user mode and is not available during Unlock Bypass mode or during Security mode. The Configuration Register Write command is preceded by the standard two-cycle *unlock* sequence, followed by the Configuration Register Write command (D0h), and finally followed by writing the contents of the Configuration Register to any address. The contents of the Configuration Register are placed on DQ31–DQ0. The contents of DQ31–DQ16 are XXXXh and are ignored. Writing the Configuration Register while an Embedded Algorithm™ or Erase Suspend modes are executing results in the contents of the Configuration Register not being updated.

The Configuration Register Read Command is fully operational if the Secured Silicon sector is enabled.

## Common Flash Interface (CFI) Command

The Common Flash Interface (CFI) command provides device size, geometry, and capability information directly to the users system. Flash devices that support CFI, have a *Query Command* that returns information about the device to the system. The Query structure contents are read at the specific address locations following a single system write cycle where:

- A 98h query command code is written to 55h address location within the device's address space
- The device is initially in any valid read state, such as *Read Array* or *Read ID Data*

Other device statistics may exist within a long sequence of commands or data input; such sequences must first be completed or terminated before writing of the 98H Query command, otherwise invalid Query data structure output may result.

Note that for data bus bits greater than DQ7 (DQ31–DQ8), the valid Query access code contains all zeroes (0s) in the upper DQ bus locations. Thus, the 16-bit Query command code is 0098h and the 32-bit Query command code is 00000098h.

To terminate the CFI operation, it is necessary to execute the Read/Reset command.

The CFI command is not permitted if the Secured Silicon sector is enabled and Simultaneous Read/Write operation is disabled once the command is entered.

See [Common Flash Interface \(CFI\) Command on page 50](#) for the specific CFI command codes.

## Password Program Command

The Password Program Command permits programming the password that is used as part of the hardware protection scheme. The actual password is 64-bits long. Depending upon the state of the WORD# pin, multiple Password Program Commands are required. For a x32 bit data bus, 2 Password Program commands are required. The user must enter the unlock cycle, password program command (38h) and the program address/data for each portion of the password when programming. There are no provisions for entering the 2-cycle unlock cycle, the password program command, and all the password data. There is no special addressing order required for programming the password. Also, when the password is undergoing programming, Simultaneous Read/Write operation is disabled. Read operations to any memory location returns the programming status. Once programming is complete, the user must issue a Read/Reset command to return the device to normal operation. Once the Password is written and verified, the Password Mode Locking Bit must be set in order to prevent verification. The Password Program Command is only capable of programming 0s. Programming a 1 after a cell is programmed as a 0 results in a time-out by the Embedded Program Algorithm™ with the cell remaining as a 0. The password is all F's when shipped from the factory. All 64-bit password combinations are valid as a password.

Password Programming is permitted if the Secured Silicon sector is enabled.

## Password Verify Command

The Password Verify Command is used to verify the Password. The Password is verifiable only when the Password Mode Locking Bit is not programmed. If the Password Mode Locking Bit is programmed and the user attempts to verify the Password, the device always drives all F's onto the DQ data bus.

The Password Verify command is permitted if the Secured Silicon sector is enabled. Also, Simultaneous Read/Write operation is disabled when the Password Verify command is executed. Only the password is returned regardless of the bank address. The lower two address bits (A0:A-1) are valid during the Password Verify. Writing the Read/Reset command returns the device back to normal operation.

## Password Protection Mode Locking Bit Program Command

The Password Protection Mode Locking Bit Program Command programs the Password Protection Mode Locking Bit, which prevents further verifies or updates to the Password. Once programmed, the Password Protection Mode Locking Bit cannot be erased! If the Password Protection Mode Locking Bit is verified as program without margin, the Password Protection Mode Locking Bit Program command can be executed to improve the program margin. Once the Password Protection Mode Locking Bit is programmed, the Persistent Sector Protection Locking Bit program circuitry is disabled, thereby forcing the device to remain in the Password Protection mode. Exiting the Mode Locking Bit Program command is accomplished by writing the Read/Reset command.

The Password Protection Mode Locking Bit Program command is permitted if the Secured Silicon sector is enabled.

## Persistent Sector Protection Mode Locking Bit Program Command

The Persistent Sector Protection Mode Locking Bit Program Command programs the Persistent Sector Protection Mode Locking Bit, which prevents the Password Mode Locking Bit from ever being programmed. If the Persistent Sector Protection Mode Locking Bit is verified as programmed without margin, the Persistent Sector Protection Mode Locking Bit Program Command should be reissued to improve program margin. By disabling the program circuitry of the Password Mode Locking Bit, the device is forced to remain in the Persistent Sector Protection mode of operation, once this bit is set. Exiting the Persistent Protection Mode Locking Bit Program command is accomplished by writing the Read/Reset command.

The Persistent Sector Protection Mode Locking Bit Program command is permitted if the Secured Silicon sector is enabled.

## PPB Lock Bit Set Command

The PPB Lock Bit Set command is used to set the PPB Lock bit if it is cleared either at reset or if the Password Unlock command was successfully executed. There is no PPB Lock Bit Clear command. Once the PPB Lock Bit is set, it cannot be cleared unless the device is taken through a power-on clear or the Password Unlock command is executed. Upon setting the PPB Lock Bit, the PPBs are latched into the DYBs. If the Password Mode Locking Bit is set, the PPB Lock Bit status is reflected as set, even after a power-on reset cycle. Exiting the PPB Lock Bit Set command is accomplished by writing the Read/Reset command.

The PPB Lock Bit Set command is permitted if the Secured Silicon sector is enabled.

## DYB Write Command

The DYB Write command is used to set or clear a DYB for a given sector. The high order address bits (A19–A11) are issued at the same time as the code 01h or 00h on DQ7–DQ0. All other DQ data bus pins are ignored during the data write cycle. The DYBs are modifiable at any time, regardless of the state of the PPB or PPB Lock Bit. The DYBs are cleared at power-up or hardware reset. Exiting the DYB Write command is accomplished by writing the Read/Reset command.

The DYB Write command is permitted if the Secured Silicon sector is enabled.

## Password Unlock Command

The Password Unlock command is used to clear the PPB Lock Bit so that the PPBs can be unlocked for modification, thereby allowing the PPBs to become accessible for modification. The exact password must be entered in order for the unlocking function to occur. This command cannot be issued any faster than 2  $\mu$ s at a time to prevent a hacker from running through the all 64-bit combinations in an attempt to correctly match a password. If the command is issued before the 2  $\mu$ s execution window for each portion of the unlock, the command is ignored.

The Password Unlock function is accomplished by writing Password Unlock command and data to the device to perform the clearing of the PPB Lock Bit. The password is 64 bits long, so the user must write the Password Unlock command 2 times for a x32 bit data bus. A0 is used to determine whether the 32 bit data quantity is used to match the upper 32 bits or lower 32 bits. Writing the Password Unlock command is address order specific. In other words, for the x32 data bus configuration, the lower 32 bits of the password are written first and then the upper 32 bits of the password are written. Writing out of sequence results in the Password Unlock not returning a match with the password and the PPB Lock Bit remains set.

Once the Password Unlock command is entered, the RY/BY# pin goes LOW indicating that the device is busy. Also, reading the small bank (25% bank) results in the DQ6 pin toggling, indicating that the Password Unlock function is in progress. Reading the large bank (75% bank) returns actual array data. Approximately 1uSec is required for each portion of the unlock. Once the first portion of the password unlock completes (RY/BY# is not driven and DQ6 does not toggle when read), the Password Unlock command is issued again, only this time with the next part of the password. The second Password Unlock command is the final command before the PPB Lock Bit is cleared (assuming a valid password). As with the first Password Unlock command, the RY/BY# signal goes LOW and reading the device results in the DQ6 pin toggling on successive read operations until complete. It is the responsibility of the microprocessor to keep track of the number of Password Unlock commands (2 for x32 bus), the order, and when to read the PPB Lock bit to confirm successful password unlock

The Password Unlock command is permitted if the Secured Silicon sector is enabled.

## PPB Program Command

The PPB Program command is used to program, or set, a given PPB. Each PPB is individually programmed (but is bulk erased with the other PPBs). The specific sector address (A19–A11) are written at the same time as the program command 60h with A6 = 0. If the PPB Lock Bit is set and the corresponding PPB is set for the sector, the PPB Program command does not execute and the command times-out without programming the PPB.

The host system must determine whether a PPB is fully programmed by noting the status of DQ0 in the sixth cycle of the PPB Program command. If DQ0 = 0, the entire six-cycle PPB Program command sequence must be reissued until DQ0 = 1.

## All PPB Erase Command

The All PPB Erase command is used to erase all PPBs in bulk. There is no means for individually erasing a specific PPB. Unlike the PPB program, no specific sector address is required. However, when the PPB erase command is written (60h) and A6 = 1, all Sector PPBs are erased in parallel. If the PPB Lock Bit is set the ALL PPB Erase command does not execute and the command times-out without erasing the PPBs. The host system must determine whether all PPB was fully erased by noting the status of DQ0 in the sixth cycle of the All PPB Erase command. If DQ0 = 1, the entire six-cycle All PPB Erase command sequence must be reissued until DQ0 = 1.

It is the responsibility of the user to preprogram all PPBs prior to issuing the All PPB Erase command. If the user attempts to erase a cleared PPB, over-erasure may occur making it difficult to program the PPB at a later time. Also note that the total number of PPB program/erase cycles is limited to 100 cycles. Cycling the PPBs beyond 100 cycles is not guaranteed.

The All PPB Erase command is permitted if the Secured Silicon sector is enabled.

## DYB Write

The DYB Write command is used for setting the DYB, which is a volatile bit that is cleared at reset. There is one DYB per sector. If the PPB is set, the sector is protected regardless of the value of the DYB. If the PPB is cleared, setting the DYB to a 1 protects the sector from programs or erases.

Since this is a volatile bit, removing power or resetting the device clears the DYBs. The bank address is latched when the command is written.

The DYB Write command is permitted if the Secured Silicon sector is enabled.

## PPB Lock Bit Set

The PPB Lock Bit set command is used for setting the DYB, which is a volatile bit that is cleared at reset. There is one DYB per sector. If the PPB is set, the sector is protected regardless of the value of the DYB. If the PPB is cleared, setting the DYB to a 1 protects the sector from programs or erases. Since this is a volatile bit, removing power or resetting the device clears the DYBs. The bank address is latched when the command is written.

The PPB Lock command is permitted if the Secured Silicon sector is enabled.

## DYB Status

The programming of the DYB for a given sector can be verified by writing a DYB status verify command to the device.

## PPB Status

The programming of the PPB for a given sector can be verified by writing a PPB status verify command to the device.

## PPB Lock Bit Status

The programming of the PPB Lock Bit for a given sector can be verified by writing a PPB Lock Bit status verify command to the device.

## Non-volatile Protection Bit Program And Erase Flow

The device uses a standard command sequence for programming or erasing the Secured Silicon Sector Protection, Password Locking, Persistent Sector Protection Mode Locking, or Persistent Protection Bits. Unlike devices that have the Single High Voltage Sector Unprotect/Protect feature, the device has the standard two-cycle unlock followed by 60h, which places the device into non-volatile bit program or erase mode. Once the mode is entered, the specific non-volatile bit status is read on DQ0. [Figure 4 on page 45](#) shows a typical flow for programming the non-volatile bit and [Figure 5 on page 48](#) shows a typical flow for erasing the non-volatile bits. The Secured Silicon Sector Protection, Password Locking, Persistent Sector Protection Mode Locking bits are **not erasable** after they are programmed. However, the PPBs are both erasable and programmable (depending upon device security).

Unlike Single High Voltage Sector Protect/Unprotect, the A6 pin no longer functions as the program/erase selector nor the program/erase margin enable. Instead, this function is accomplished by issuing the specific command for either program (68h) or erase (60h).

In asynchronous mode, the DQ6 toggle bit indicates whether the program or erase sequence is active. (In synchronous mode, ADV# indicates the status.) If the DQ6 toggle bit toggles with either OE# or CE#, the non-volatile bit program or erase operation is in progress. When DQ6 stops toggling, the value of the non-volatile bit is available on DQ0.



**Table 4I. Memory Array Command Definitions**

Command (Notes)		Cycles	Bus Cycles (Notes 1–4)											
			First		Second		Third		Fourth		Fifth		Sixth	
			Addr	Data	Addr	Data	Addr	Data	Addr	Data	Addr	Data	Addr	Data
Read (5)		1	RA	RD										
Reset (6)		1	XXX	F0										
Autoselect (7)	Manufacturer ID	4	555	AA	2AA	55	555	90	BA+X00	01				
	Device ID (11)	6	555	AA	2AA	55	555	90	BA+X01	7E	BA+X0E	09 for 32 Mb 36 or 08 for 16 Mb	BA+X0F	00/01
Program		4	555	AA	2AA	55	555	A0	PA	PD				
Chip Erase		6	555	AA	2AA	55	555	80	555	AA	2AA	55	555	10
Sector Erase		6	555	AA	2AA	55	555	80	555	AA	2AA	55	SA	30
Program/Erase Suspend (12)		1	BA	B0										
Program/Erase Resume (13)		1	BA	30										
CFI Query (14, 15)		1	55	98										
Accelerated Program (16)		2	XX	A0	PA	PD								
Configuration Register Verify (15)		3	555	AA	2AA	55	BA+555	C6	BA+XX	RD				
Configuration Register Write (17)		4	555	AA	2AA	55	555	D0	XX	WD				
Unlock Bypass Entry (18)		3	555	AA	2AA	55	555	20						
Unlock Bypass Program (18)		2	XX	A0	PA	PD								
Unlock Bypass Erase (18)		2	XX	80	XX	10								
Unlock Bypass CFI (14, 18)		1	XX	98										
Unlock Bypass Reset (18)		2	XX	90	XX	00								

**Legend:**

BA = Bank Address. The set of addresses that comprise a bank. The system may write any address within a bank to identify that bank for a command.

PA = Program Address (Amax–A0). Addresses latch on the falling edge of the WE# or CE# pulse, whichever happens later.

PD = Program Data (DQmax–DQ0) written to location PA. Data latches on the rising edge of WE# or CE# pulse, whichever happens first.

**Notes:**

- See Table 27 on page 23 for description of bus operations.
- All values are in hexadecimal.
- Shaded cells in table denote read cycles. All other cycles are write operations.
- During unlock cycles, (lower address bits are 555 or 2AAh as shown in table) address bits higher than A11 (except where BA is required) and data bits higher than DQ7 are don't cares.
- No unlock or command cycles required when bank is reading array data.
- The Reset command is required to return to the read mode (or to the erase-suspend-read mode if previously in Erase Suspend) when a bank is in the autoselect mode, or if DQ5 goes high (while the bank is providing status information).
- The fourth cycle of the autoselect command sequence is a read cycle. The system must provide the bank address to obtain the manufacturer ID or device ID information. See Autoselect Command on page 43 for more information.
- This command cannot be executed until The Unlock Bypass command must be executed before writing this command sequence. The Unlock Bypass Reset command must be executed to return to normal operation.
- This command is ignored during any embedded program, erase or suspended operation.

RA = Read Address (Amax–A0).

RD = Read Data. Data DQmax–DQ0 at address location RA.

SA = Sector Address. The set of addresses that comprise a sector. The system may write any address within a sector to identify that sector for a command.

WD = Write Data. See Configuration Register on page 31 definition for specific write data. Data latched on rising edge of WE#.

X = Don't care

- Valid read operations include asynchronous and burst read mode operations.
- The device ID must be read across the fourth, fifth, and sixth cycles. 00h in the sixth cycle indicates ordering option 00, 01h indicates ordering option 01.
- The system may read and program in non-erasing sectors, or enter the autoselect mode, when in the Program/Erase Suspend mode. The Program/Erase Suspend command is valid only during a sector erase operation, and requires the bank address.
- The Program/Erase Resume command is valid only during the Erase Suspend mode, and requires the bank address.
- Command is valid when device is ready to read array data or when device is in autoselect mode.
- Asynchronous read operations.
- ACC must be at V<sub>ID</sub> during the entire operation of this command.
- Command is ignored during any Embedded Program, Embedded Erase, or Suspend operation.
- The Unlock Bypass Entry command is required prior to any Unlock Bypass operation. The Unlock Bypass Reset command is required to return to the read mode.



**Table 42. Sector Protection Command Definitions**

Command (Notes)	Cycles	Bus Cycles (Notes 1 – 4)											
		First		Second		Third		Fourth		Fifth		Sixth	
		Addr	Data	Addr	Data	Addr	Data	Addr	Data	Addr	Data	Addr	Data
Reset	1	XXX	F0										
Secured Silicon Sector Entry	3	555	AA	2AA	55	555	88						
Secured Silicon Sector Exit	4	555	AA	2AA	55	555	90	XX	00				
Secured Silicon Protection Bit Status	6	555	AA	2AA	55	555	60	OW	RD(0)				
Password Program (5, 7, 8)	4	555	AA	2AA	55	555	38	PWA[0-1]	PWD[0-1]				
Password Verify	4	555	AA	2AA	55	555	C8	PWA[0-1]	PWD[0-1]				
Password Unlock (7, 8)	5	555	AA	2AA	55	555	28	PWA[0-1]	PWD[0-1]				
PPB Program (5, 6)	6	555	AA	2AA	55	555	60	SG+WP	68	SG+WP	48	SG+WP	RD(0)
All PPB Erase (5, 9, 10)	6	555	AA	2AA	55	555	60	WP	60	WP	40	WP	RD(0)
PPB Status (11, 12)	4	555	AA	2AA	55	BA+555	90	SA+X02	00/01				
PPB Lock Bit Set	3	555	AA	2AA	55	555	78						
PPB Lock Bit Status	4	555	AA	2AA	55	BA+555	58	SA	RD(1)				
DYB Write (7)	4	555	AA	2AA	55	555	48	SA	X1				
DYB Erase (7)	4	555	AA	2AA	55	555	48	SA	X0				
DYB Status (12)	4	555	AA	2AA	55	BA+555	58	SA	RD(0)				
PPMLB Program (5, 6)	6	555	AA	2AA	55	555	60	PL	68	PL	48	PL	RD(0)
PPMLB Status (5)	6	555	AA	2AA	55	555	60	PL	RD(0)				
SPMLB Program (5, 6)	6	555	AA	2AA	55	555	60	SL	68	SL	48	SL	RD(0)
SPMLB Status (5)	6	555	AA	2AA	55	555	60	SL	RD(0)				

**Legend:**

DYB = Dynamic Protection Bit  
 OW = Address (A5–A0) is (011X10).  
 PPB = Persistent Protection Bit  
 PWA = Password Address. A0 selects between the low and high 32-bit portions of the 64-bit Password  
 PWD = Password Data. Must be written over two cycles.  
 PL = Password Protection Mode Lock Address (A5–A0) is (001X10)  
 RD(0) = Read Data DQ0 protection indicator bit. If protected, DQ0 = 1, if unprotected, DQ0 = 0.  
 RD(1) = Read Data DQ1 protection indicator bit. If protected, DQ1 = 1, if unprotected, DQ1 = 0.

SA = Sector Address. The set of addresses that comprise a sector. The system may write any address within a sector to identify that sector for a command.  
 SG = Sector Group Address  
 BA = Bank Address. The set of addresses that comprise a bank. The system may write any address within a bank to identify that bank for a command.  
 SL = Persistent Protection Mode Lock Address (A5–A0) is (010X10)  
 WP = PPB Address (A5–A0) is (111010)  
 X = Don't care  
 PPMLB = Password Protection Mode Locking Bit  
 SPMLB = Persistent Protection Mode Locking Bit

**Notes:**

- See Table 27 on page 23 for description of bus operations.
- All values are in hexadecimal.
- Shaded cells in table denote read cycles. All other cycles are write operations.
- During unlock cycles, (lower address bits are 555 or 2AAh as shown in table) address bits higher than A11 (except where BA is required) and data bits higher than DQ7 are don't cares.
- The reset command returns the device to reading the array.
- The fourth cycle programs the addressed locking bit. The fifth and sixth cycles are used to validate whether the bit is fully programmed. If DQ0 (in the sixth cycle) reads 0, the program command must be issued and verified again.
- Data is latched on the rising edge of WE#.
- The entire four bus-cycle sequence must be entered for each portion of the password.
- The fourth cycle erases all PPBs. The fifth and sixth cycles are used to validate whether the bits were fully erased. If DQ0 (in the sixth cycle) reads 1, the erase command must be issued and verified again.
- Before issuing the erase command, all PPBs should be programmed in order to prevent over-erasure of PPBs.
- In the fourth cycle, 00h indicates PPB set; 01h indicates PPB not set.
- The status of additional PPBs and DYBs may be read (following the fourth cycle) without reissuing the entire command sequence.

## Write Operation Status

The device provides several bits to determine the status of a write operation: DQ2, DQ3, DQ5, DQ6, DQ7, and RY/BY#. [Table 43](#) and the following subsections describe the functions of these bits. DQ7, RY/BY#, and DQ6 each offer a method for determining whether a program or erase operation is complete or in progress. These three bits are discussed first.

### DQ7: Data# Polling

The device features a Data# polling flag as a method to indicate to the host system whether the embedded algorithms are in progress or are complete. During the Embedded Program Algorithm, an attempt to read the bank in which programming was initiated produces the complement of the data last written to DQ7. Upon completion of the Embedded Program Algorithm, an attempt to read the device produces the true last data written to DQ7. Note that DATA# polling returns invalid data for the address being programmed or erased.

For example, the data read for an address programmed as 0000 0000 1000 0000b, returns XXXX XXXX 0XXX XXXXb during an Embedded Program operation. Once the Embedded Program Algorithm is complete, the true data is read back on DQ7. Note that at the instant when DQ7 switches to true data, the other bits may not yet be true. However, they are all true data on the next read from the device. Please note that Data# polling may give misleading status when an attempt is made to write to a protected sector.

For chip erase, the Data# polling flag is valid after the rising edge of the sixth WE# pulse in the six write pulse sequence. For sector erase, the Data# polling is valid after the last rising edge of the sector erase WE# pulse. Data# polling must be performed at sector addresses within any of the sectors being erased and not a sector that is a protected sector. Otherwise, the status may not be valid. DQ7 = 0 during an Embedded Erase Algorithm (chip erase or sector erase operation), but returns a 1 after the operation completes because it drops back into read mode.

In asynchronous mode, just prior to the completion of the Embedded Algorithm operations, DQ7 may change asynchronously while OE# is asserted low. (In synchronous mode, ADV# exhibits this behavior.) The status information may be invalid during the instance of transition from status information to array (memory) data. An extra validity check is therefore specified in the data polling algorithm. The valid array data on DQ31–DQ0 is available for reading on the next successive read attempt.

The Data# polling feature is only active during the Embedded Programming Algorithm, Embedded Erase Algorithm, Erase Suspend, Erase Suspend-Program mode, or sector erase time-out.

If the user attempts to write to a protected sector, Data# polling is activated for about 1  $\mu$ s: the device then returns to read mode, with the data from the protected sector unchanged. If the user attempts to erase a protected sector, Toggle Bit (DQ6) is activated for about 150  $\mu$ s; the device then returns to read mode, without having erased the protected sector.

[Table 43](#) shows the outputs for Data# Polling on DQ7. [Figure 6 on page 57](#) shows the Data# Polling algorithm. [Figure 23](#) shows the timing diagram for synchronous status DQ7 data polling.

### RY/BY#: Ready/Busy#

The device provides a RY/BY# open drain output pin as a way to indicate to the host system that the Embedded Algorithms are either in progress or completed. If the output is low, the device is busy with either a program, erase, or reset operation. If the output is floating, the device is ready to accept any read/write or erase operation. When the RY/BY# pin is low, the device does not accept any additional program or erase commands with the exception of the Erase suspend command. If the device enters Erase Suspend mode, the RY/BY# output is floating. For programming, the RY/BY# is valid (RY/BY# = 0) after the rising edge of the fourth WE# pulse in the four write pulse sequence. For chip erase, the RY/BY# is valid after the rising edge of the sixth WE# pulse

in the six write pulse sequence. For sector erase, the RY/BY# is also valid after the rising edge of the sixth WE# pulse.

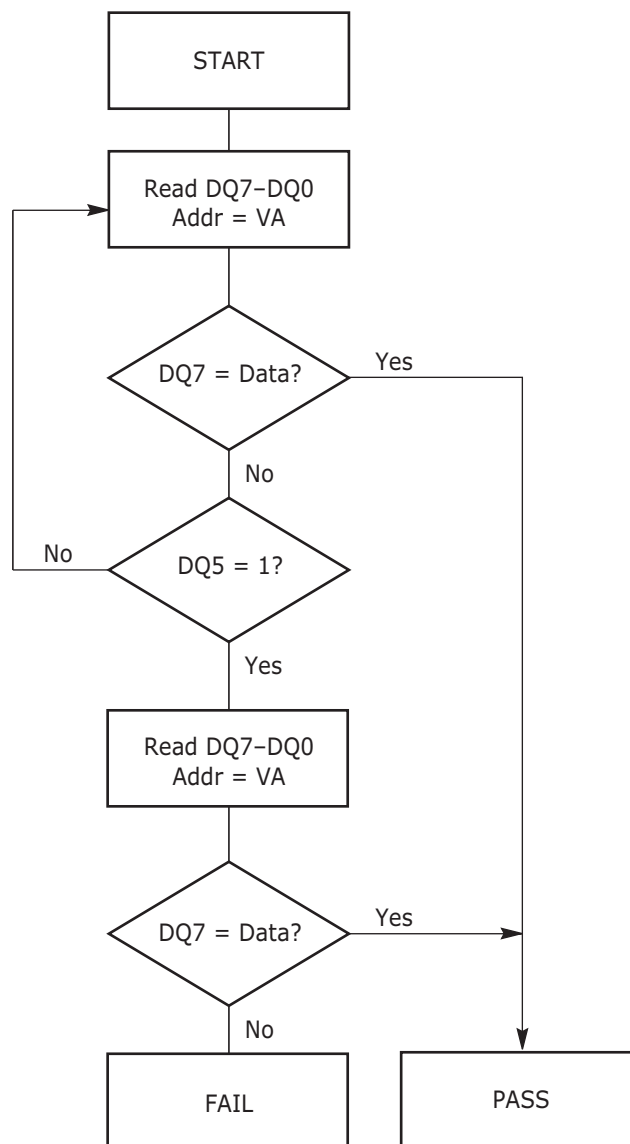

**Notes:**

1. VA = Valid address for programming. During a sector erase operation, a valid address is an address within any sector selected for erasure. During chip erase, a valid address is any non-protected sector address.
2. DQ7 should be rechecked even if DQ5 = 1 because DQ7 may change simultaneously with DQ5

**Figure 6. Data# Polling Algorithm**

If RESET# is asserted during a program or erase operation, the RY/BY# pin remains a 0 (busy) until the internal reset operation is complete, which requires a time of  $t_{\text{READY}}$  (during Embedded Algorithms). The system can thus monitor RY/BY# to determine whether the reset operation is complete. If RESET# is asserted when a program or erase operation is not executing (RY/BY# pin is *floating*), the reset operation is completed in a time of  $t_{\text{READY}}$  (not during Embedded Algorithms). The system can read data  $t_{\text{RH}}$  after the RESET# pin returns to  $V_{\text{IH}}$ .

Since the RY/BY# pin is an open-drain output, several RY/BY# pins can be tied together in parallel with a pull-up resistor to  $V_{\text{CC}}$ . An external pull-up resistor is required to take RY/BY# to a  $V_{\text{IH}}$  level since the output is an open drain.

Table 43 shows the outputs for RY/BY#. Figures 15, 19, and 21 show RY/BY# for read, reset, program, and erase operations, respectively.

## DQ6: Toggle Bit I

Toggle Bit I on DQ6 indicates whether an Embedded Program or Erase algorithm is in progress or complete, or whether the device entered the Erase Suspend mode. Toggle Bit I may be read at any address, and is valid after the rising edge of the final WE# pulse in the command sequence (prior to the program or erase operation), and during the sector erase time-out.

During an Embedded Program or Erase algorithm operation, two immediately consecutive read cycles to any address cause DQ6 to toggle. When the operation is complete, DQ6 stops toggling. For asynchronous mode, either OE# or CE# can be used to control the read cycles. For synchronous mode, the rising edge of ADV# is used or the rising edge of clock while ADV# is Low.

After an erase command sequence is written, if all sectors selected for erasing are protected, DQ6 toggles for approximately 100  $\mu$ s, then returns to reading array data. If not all selected sectors are protected, the Embedded Erase algorithm erases the unprotected sectors, and ignores the selected sectors that are protected.

The system can use DQ6 and DQ2 together to determine whether a sector is actively erasing or is erase-suspended. When the device is actively erasing (that is, the Embedded Erase algorithm is in progress), DQ6 toggles. When the device enters the Erase Suspend mode, DQ6 stops toggling. However, the system must also use DQ2 to determine which sectors are erasing or erase-suspended. Alternatively, the system can use DQ7 (See [DQ7: Data# Polling on page 56](#)).

If a program address falls within a protected sector, DQ6 toggles for approximately 1  $\mu$ s after the program command sequence is written, then returns to reading array data.

DQ6 also toggles during the erase-suspend-program mode, and stops toggling once the Embedded Program algorithm is complete.

Table 43 shows the outputs for Toggle Bit I on DQ6. Figure 7 shows the toggle bit algorithm in flowchart form, and [Reading Toggle Bits DQ6/DQ2 on page 59](#) explains the algorithm. Figure 24 shows the toggle bit timing diagrams. Figure 24 shows the differences between DQ2 and DQ6 in graphical form. Also see [DQ2: Toggle Bit II on page 58](#). Figure 24 shows the timing diagram for synchronous toggle bit status.

## DQ2: Toggle Bit II

The *Toggle Bit II* on DQ2, when used with DQ6, indicates whether a particular sector is actively erasing (that is, the Embedded Erase algorithm is in progress), or whether that sector is erase-suspended. Toggle Bit II is valid after the rising edge of the final WE# pulse in the command sequence.

DQ2 toggles when the system performs two immediately consecutive reads at addresses within those sectors that were selected for erasure. (For asynchronous mode, either OE# or CE# can be used to control the read cycles. For synchronous mode, ADV# is used.) But DQ2 cannot distinguish whether the sector is actively erasing or is erase-suspended. DQ6, by comparison, indicates whether the device is actively erasing, or is in Erase Suspend, but cannot distinguish which sectors are selected for erasure. Thus, both status bits are required for sector and mode information. Refer to Table 43 to compare outputs for DQ2 and DQ6.

Toggle bit algorithm in is shown in Figure 7 in flowchart form, and the algorithm is explained in [Reading Toggle Bits DQ6/DQ2 on page 59](#). Also see [DQ6: Toggle Bit I on page 58](#). Figure 24 shows the toggle bit timing diagram. Figure 25 shows the differences between DQ2 and DQ6 in graphical form. Figure 26 shows the timing diagram for synchronous DQ2 toggle bit status.

## Reading Toggle Bits DQ6/DQ2

Refer to [Figure 24](#) for the following discussion. Whenever the system initially begins reading toggle bit status, it must perform two immediately consecutive reads of DQ7–DQ0 to determine whether a toggle bit is toggling. Typically, the system would note and store the value of the toggle bit after the first read. After the second read, the system would compare the new value of the toggle bit with the first. If the toggle bit is not toggling, the device completed the program or erase operation. The system can read array data on DQ7–DQ0 on the following read cycle.

However, if after the initial two immediately consecutive read cycles, the system determines that the toggle bit is still toggling, the system also should note whether the value of DQ5 is high (See [DQ5: Exceeded Timing Limits on page 60](#)). If it is, the system should then determine again whether the toggle bit is toggling, since the toggle bit may have stopped toggling just as DQ5 went high. If the toggle bit is no longer toggling, the device successfully completed the program or erase operation. If it is still toggling, the device did not complete the operation successfully, and the system must write the reset command to return to reading array data.

The remaining scenario is that the system initially determines that the toggle bit is toggling and DQ5 has not gone high. The system may continue to monitor the toggle bit and DQ5 through successive read cycles, determining the status as described in the previous paragraph. Alternatively, it may choose to perform other system tasks. In this case, the system must start at the beginning of the algorithm when it returns to determine the status of the operation (top of [Figure 7](#)).

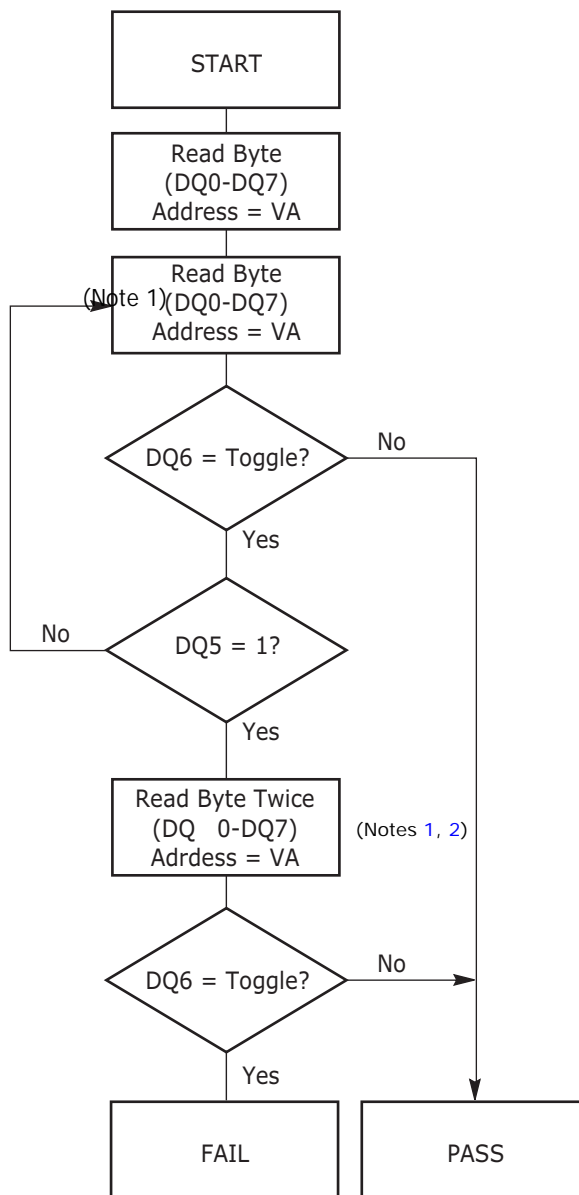

**Notes:**

1. Read toggle bit with two immediately consecutive reads to determine whether or not it is toggling.
2. Recheck toggle bit because it may stop toggling as DQ5 changes to 1.

**Figure 7. Toggle Bit Algorithm**

### DQ5: Exceeded Timing Limits

DQ5 indicates whether the program or erase time exceeded a specified internal pulse count limit. Under these conditions DQ5 produces a 1. This is a failure condition that indicates the program or erase cycle was not successfully completed.

The DQ5 failure condition may appear if the system tries to program a 1 to a location that is previously programmed to 0. **Only an erase operation can change a 0 back to a 1.** Under this condition, the device halts the operation, and when the operation exceeds the timing limits, DQ5 produces a 1.

Under both these conditions, the system must issue the reset command to return the device to reading array data.

## DQ3: Sector Erase Timer

After writing a sector erase command sequence, the system may read DQ3 to determine whether or not an erase operation started. (The sector erase timer does not apply to the chip erase command.) If additional sectors are selected for erasure, the entire time-out also applies after each additional sector erase command. When the time-out is complete, DQ3 switches from 0 to 1. The system may ignore DQ3 if the system can guarantee that the time between additional sector erase commands is always less than 50  $\mu$ s. Also see [Sector Erase Command on page 46](#).

After the sector erase command sequence is written, the system should read the status on DQ7 (Data# Polling) or DQ6 (Toggle Bit I) to ensure the device accepted the command sequence, and then read DQ3. If DQ3 is 1, the internally controlled erase cycle started; all further commands (other than Erase Suspend) are ignored until the erase operation is complete. If DQ3 is 0, the device accepts additional sector erase commands. To ensure the command is accepted, the system software should check the status of DQ3 prior to and following each subsequent sector erase command. If DQ3 is high on the second status check, the last command might not have been accepted. [Table 43](#) shows the outputs for DQ3.

**Table 43. Write Operation Status**

Operation		DQ7 (Note 2)	DQ6	DQ5 (Note 1)	DQ3	DQ2 (Note 2)	RY/BY#
Standard Mode	Embedded Program Algorithm	DQ7#	Toggle	0	N/A	No toggle	0
	Embedded Erase Algorithm	0	Toggle	0	1	Toggle	0
Erase Suspend Mode	Reading within Erase Suspended Sector	1	No toggle	0	N/A	Toggle	1
	Reading within Non-Erase Suspended Sector	Data	Data	Data	Data	Data	1
	Erase-Suspend-Program	DQ7#	Toggle	0	N/A	N/A	0

**Notes:**

1. DQ5 switches to 1 when an Embedded Program or Embedded Erase operation exceeds the maximum timing limits. See [DQ5: Exceeded Timing Limits](#) for more information.
2. DQ7 and DQ2 require a valid address when reading status information. See [DQ7: Data# Polling](#) and [DQ2: Toggle Bit II](#) for further details.

## Absolute Maximum Ratings

Storage Temperature, Plastic Packages . . . . .	-65°C to +150°C
Ambient Temperature with Power Applied . . . . .	-65°C to +145°C
V <sub>CC</sub> , V <sub>IO</sub> (Note 1, Note 5) . . . . .	-0.5 V to + 3.0V (16Mb), -0.5V to + 2.75V (32Mb)
ACC, A9, OE#, and RESET# (Note 2) . . . . .	-0.5 V to +13.0 V
Address, Data, Control Signals	
Except CLK (Note 1, Note 6) . . . . .	-0.5V to 3.6V (16 Mb), -0.5 V to 2.75 V (32 Mb)
All other pins (Note 1, Note 6) . . . . .	-0.5V to 3.6V (16 Mb), -0.5 V to 2.75 V (32 Mb)
Output Short Circuit Current (Note 3) . . . . .	200 mA

**Notes:**

1. Minimum DC voltage on input or I/O pins is -0.5 V. During voltage transitions, input at I/O pins may overshoot V<sub>SS</sub> to -2.0V for periods of up to 20 ns. See Figure 9. Maximum DC voltage on output and I/O pins is 3.6V (16Mb), 2.75V (32Mb). During voltage transitions output pins may overshoot to V<sub>CC</sub> + 2.0V for periods up to 20 ns. See Figure 9.
2. Minimum DC input voltage on pins ACC, A9, OE#, and RESET# is -0.5 V. During voltage transitions, A9, OE#, and RESET# may overshoot V<sub>SS</sub> to -2.0V for periods of up to 20 ns. See Figure 8. Maximum DC input voltage on pin A9 and OE# is +13.0 V which may overshoot to 14.0 V for periods up to 20 ns.
3. No more than one output may be shorted to ground at a time. Duration of the short circuit should not be greater than one second.
4. Stresses above those listed under *Absolute Maximum Ratings* may cause permanent damage to the device. This is a stress rating only; functional operation of the device at these or any other conditions above those indicated in the operational sections of this data sheet is not implied. Exposure of the device to absolute maximum rating conditions for extended periods may affect device reliability.
5. Parameter describes V<sub>IO</sub> power supply.
6. Parameter describes I/O pin voltage tolerances.

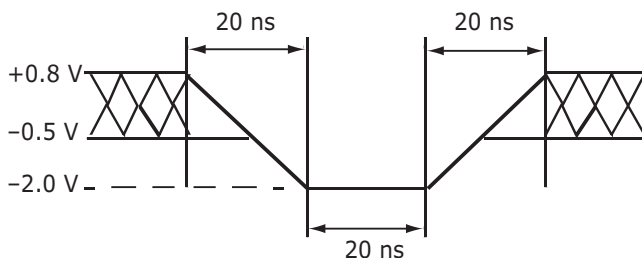

**Figure 8. Maximum Negative Overshoot Waveform**

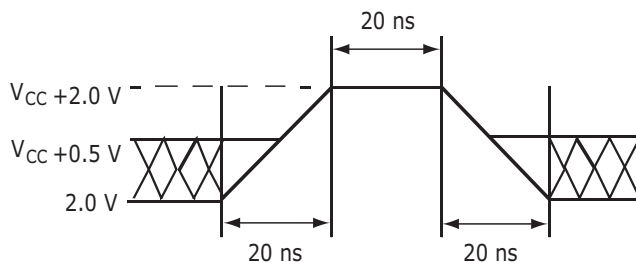

**Figure 9. Maximum Positive Overshoot Waveform**



## Operating Ranges

### Industrial (I) Devices

Ambient Temperature ( $T_A$ ) . . . . .  $-40^{\circ}\text{C}$  to  $+85^{\circ}\text{C}$

### Extended (E) Devices

Ambient Temperature ( $T_A$ ) . . . . .  $-40^{\circ}\text{C}$  to  $+125^{\circ}\text{C}$

### $V_{CC}$ Supply Voltages

$V_{CC}$  for 2.6 V regulated voltage range . . . . . 2.50 V to 2.75 V

### $V_{IO}$ Supply Voltages

$V_{IO}$  . . . . . 1.65 V to 3.6 V (16 Mb), 1.65 V to 2.75 V (32 Mb)

**Note:** Operating ranges define those limits between which the functionality of the device is guaranteed.

## DC Characteristics

### CMOS Compatible

Parameter	Description	Test Conditions	Min	Typ	Max	Unit
$I_{LI}$	Input Load Current	$V_{IN} = V_{SS}$ to $V_{IO}$ , $V_{IO} = V_{IO\ max}$			$\pm 1.0$	$\mu A$
$I_{LIWP}$	WP# Input Load Current	$V_{IN} = V_{SS}$ to $V_{IO}$ , $V_{IO} = V_{IO\ max}$			-25	
$I_{LIT}$	A9, ACC Input Load Current	$V_{CC} = V_{CC\ max}$ ; A9 = 12.5 V			35	
$I_{LO}$	Output Leakage Current	$V_{OUT} = V_{SS}$ to $V_{CC}$ , $V_{CC} = V_{CC\ max}$			$\pm 1.0$	
$I_{CCB}$	$V_{CC}$ Active Burst Read Current (1)	$CE\# = V_{IL}$ , OE# = $V_{IL}$	56 MHz 66, 75 MHz	8 Double Word	70 90	mA
$I_{CC1}$	$V_{CC}$ Active Asynchronous Read Current (1)	$CE\# = V_{IL}$ , OE# = $V_{IL}$	1 MHz		10	
$I_{CC3}$	$V_{CC}$ Active Program Current (2, 4)	$CE\# = V_{IL}$ , OE# = $V_{IH}$ , ACC = $V_{IH}$		40	50	
$I_{CC4}$	$V_{CC}$ Active Erase Current (2, 4)	$CE\# = V_{IL}$ , OE# = $V_{IH}$ , ACC = $V_{IH}$		20	50	
$I_{CC5}$	$V_{CC}$ Standby Current (CMOS)	$V_{CC} = V_{CC\ max}$ , CE# = $V_{CC} \pm 0.3\ V$			60	$\mu A$
$I_{CC6}$	$V_{CC}$ Active Current (Read While Write)	$CE\# = V_{IL}$ , OE# = $V_{IL}$		30	90	mA
$I_{CC7}$	$V_{CC}$ Reset Current ( )	RESET# = $V_{IL}$			60	$\mu A$
$I_{CC8}$	Automatic Sleep Mode Current	$V_{IH} = V_{CC} \pm 0.3\ V$ , $V_{IL} = V_{SS} \pm 0.3\ V$			60	$\mu A$
$I_{ACC}$	$V_{ACC}$ Acceleration Current	ACC = $V_{HH}$			20	mA
$V_{IL}$	Input Low Voltage		-0.5		$0.3 \times V_{IO}$	V
$V_{IH}$	Input High Voltage		$0.7 \times V_{IO}$		$V_{CC}$	
$V_{ILCLK}$	CLK Input Low Voltage		-0.2		$0.3 \times V_{IO}$	
$V_{IHCLK}$	CLK Input High Voltage		$0.7 \times V_{CC}$		2.75	
$V_{ID}$	Voltage for Autoselect	$V_{CC} = 2.5\ V$	11.5		12.5	
$V_{OL}$	Output Low Voltage	$I_{OL} = 4.0\ mA$ , $V_{CC} = V_{CC\ min}$			0.45	
$I_{OLRB}$	RY/BY#, Output Low Current	$V_{OL} = 0.4\ V$	8			mA
$V_{HH}$	Accelerated (ACC pin) High Voltage	$I_{OH} = -2.0\ mA$ , $V_{CC} = V_{CC\ min}$	$0.85 \times V_{CC}$			
$V_{OH}$	Output High Voltage	$I_{OH} = -100\ \mu A$ , $V_{CC} = V_{CC\ min}$	$V_{IO} - 0.1$			V
$V_{LKO}$	Low $V_{CC}$ Lock-Out Voltage (3)		1.6		2.0	

**Notes:**

1. The  $I_{CC}$  current listed includes both the DC operating current and the frequency dependent component.
2.  $I_{CC}$  active while Embedded Erase or Embedded Program is in progress.
3. Not 100% tested.
4. Maximum  $I_{CC}$  specifications are tested with  $V_{CC} = V_{CC\ max}$ .

## DC Characteristics

### Zero Power Flash

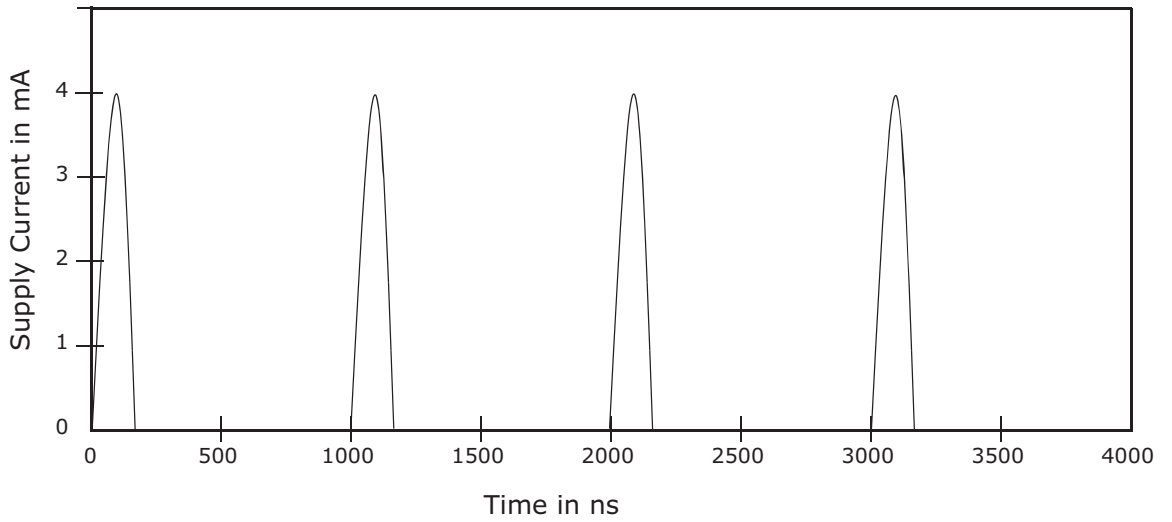

Note: Addresses are switching at 1 MHz

Figure 10.  $I_{CC1}$  Current vs. Time (Showing Active and Automatic Sleep Currents)

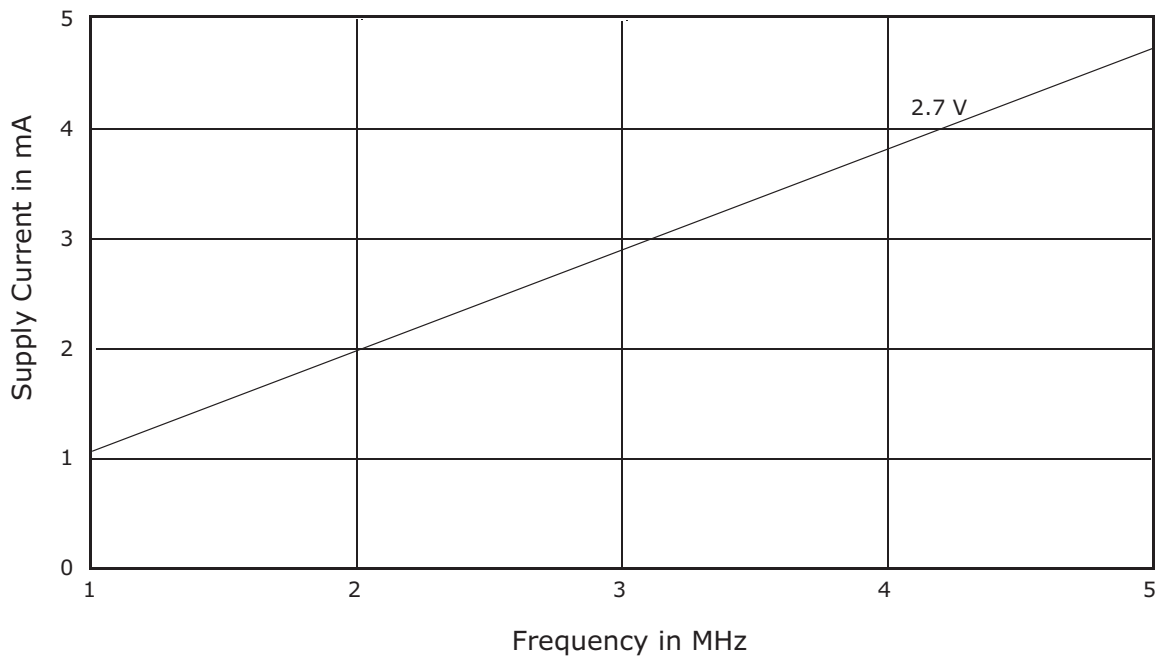
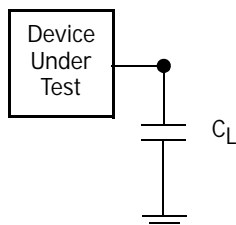

Figure 11. Typical  $I_{CC1}$  vs. Frequency

## Test Conditions



Note: Diodes are IN3064 or equivalent

Figure 12. Test Setup

## Test Specifications

Table 44. Test Specifications

Test Condition	40 MHz, 56 MHz	66 MHz, 75MHz	Unit
Output Load	1 TTL gate		
Output Load Capacitance, $C_L$ (including jig capacitance)	30	100	pF
Input Rise and Fall Times	5		ns
Input Pulse Levels	0.0 V – $V_{IO}$		V
Input timing measurement reference levels	$V_{IO}/2$		
Output timing measurement reference levels	$V_{IO}/2$		

## Key to Switching Waveforms

Waveform	Inputs	Outputs
	Steady	
	Changing from H to L	
	Changing from L to H	
	Don't Care, Any Change Permitted	Changing, State Unknown
	Does Not Apply	Center Line is High Impedance State (High Z)

## Switching Waveforms

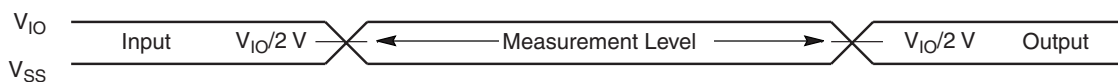

Figure 13. Input Waveforms and Measurement Levels

## AC Characteristics

### $V_{CC}$ and $V_{IO}$ Power-up

Parameter	Description	Test Setup	Speed	Unit
$t_{VCS}$	$V_{CC}$ Setup Time	Min	50	$\mu s$
$t_{VIOS}$	$V_{IO}$ Setup Time			
$t_{RSTH}$	RESET# Low Hold Time			

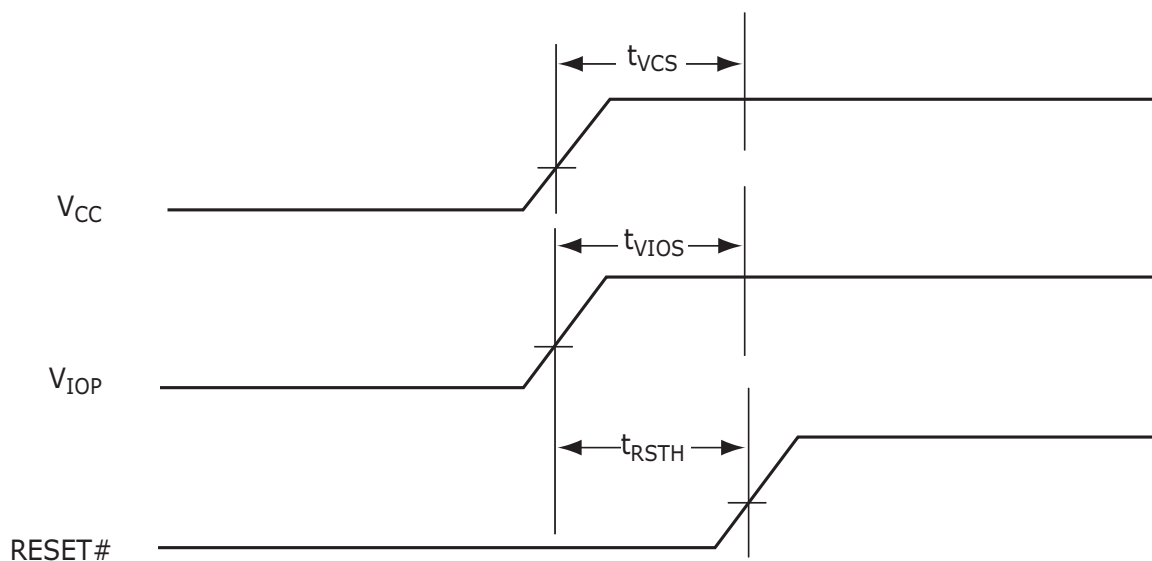

Figure 14.  $V_{CC}$  and  $V_{IO}$  Power-up Diagram

# AC Characteristics

## Asynchronous Read Operations

Parameter		Description	Test Setup	Speed Options				Unit
JEDEC	Std.			75 MHz, OR	66 MHz, OP	56 MHz, OM	40 MHz, OJ	
$t_{AVAV}$	$t_{RC}$	Read Cycle Time (Note 1)	Min	48	54	64	67	ns
$t_{AVQV}$	$t_{ACC}$	Address to Output Delay	CE# = $V_{IL}$ OE# = $V_{IL}$	Max	48	54	64	
$t_{ELQV}$	$t_{CE}$	Chip Enable to Output Delay	OE# = $V_{IL}$	Max	52	58	69	
$t_{GLOV}$	$t_{OE}$	Output Enable to Output Delay		Max	20		28	
$t_{EHOZ}$	$t_{DF}$	Chip Enable to Output High Z Note 1		Max	10			
$t_{GHOZ}$	$t_{DF}$	Output Enable to Output High Z Note 1	Min	2				
			Max	10				
	$t_{OEh}$	Output Enable Hold Time Note 1	Read	0				
			Toggle and Data# Polling	10				
$t_{AXQX}$	$t_{OH}$	Output Hold Time From Addresses, CE# or OE#, Whichever Occurs First Note 1	Min	2				

**Notes:**

1. Not 100% tested.
2. See Figure 12 and Table 44 for test specifications

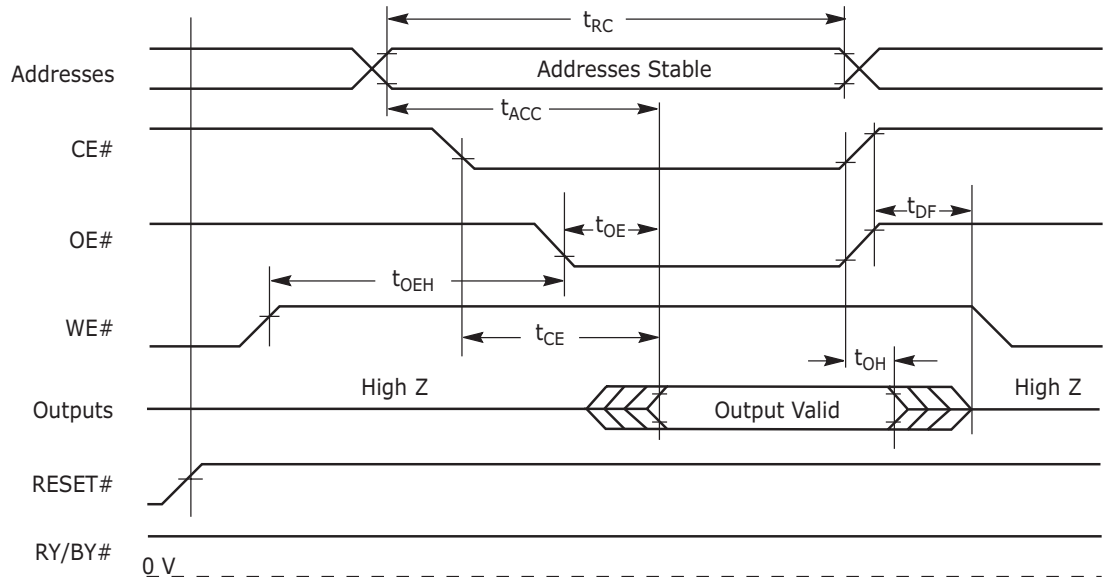

Figure 15. Conventional Read Operations Timings

## AC Characteristics

### Burst Mode Read for 32 Mb & 16 Mb

Parameter		Description		Speed Options				Unit
JEDEC	Std.			75 MHz, OR 32 MHz	66 MHz, OP	56 MHz, OM	40 MHz, OJ	
	t <sub>BACC</sub>	Burst Access Time Valid Clock to Output Delay	Max	7.5 FBGA	9 FBGA 9.5 PQFP	10 FBGA 10 PQFP	17	ns
	t <sub>ADVCS</sub>	ADV# Setup Time to Rising Edge of CLK	Min	5.75	6			
	t <sub>ADVCH</sub>	ADV# Hold Time from Rising Edge of CLK	Min	1.5	2			
	t <sub>ADVP</sub>	ADV# Pulse Width (32Mb, 75MHz)	Min	12	13	15	22	
	t <sub>DVCH</sub>	Valid Data Hold from CLK (Note Note:)	Min	2		3		
	t <sub>DIND</sub>	CLK to Valid IND/WAIT#	Max	7.5 FBGA	9 FBGA 9.5 PQFP	10 FBGA 10 PQFP	17	
	t <sub>INDH</sub>	IND/WAIT# Hold from CLK	Min	2		3		
	t <sub>IACC</sub>	CLK to Valid Data Out, Initial Burst Access	Max	48	54	64	67	
	t <sub>CLK</sub>	CLK Period	Min	13.	15	18	25	
			Max	60				
	t <sub>CLKR</sub>	CLK Rise Time	Max	3				
	t <sub>CLKF</sub>	CLK Fall Time	Max	3				
	t <sub>CKL</sub>	CLK Low Time	Min	2	2.5		3	
	t <sub>CLKH</sub>	CLK to High Time	Min	2	2.5		3	
	t <sub>CES</sub>	CE# Setup Time to Clock	Min	6				
	t <sub>CH</sub>	CE# Hold Time	Min	16 Mb = 3 32 Mb = 8				
	t <sub>ACS</sub>	Address Setup Time to CLK	Min	6				
	t <sub>ACH</sub>	Address Hold Time from ADV# Rising Edge of CLK while ADV# is Low	Min	5				
	t <sub>OE</sub>	Output Enable to Output Valid	Max	20			28	
	t <sub>DF</sub>	t <sub>OEZ</sub> Output Enable to Output High Z (Note Note:)	Min	2	2	3	3	
			Max	7.5	10	15	17	
	t <sub>EHOZ</sub>	t <sub>CEZ</sub> Chip Enable to Output High Z (Note Note:)	Max	7.5	10	15	17	
	t <sub>WADVH</sub>	WE hold time after ADV falling edge	Min	0				
	t <sub>WCKS</sub>	WE rising edge setup time to clock rising edge	Min	5				

**Note:** Not 100% tested.

## AC Characteristics

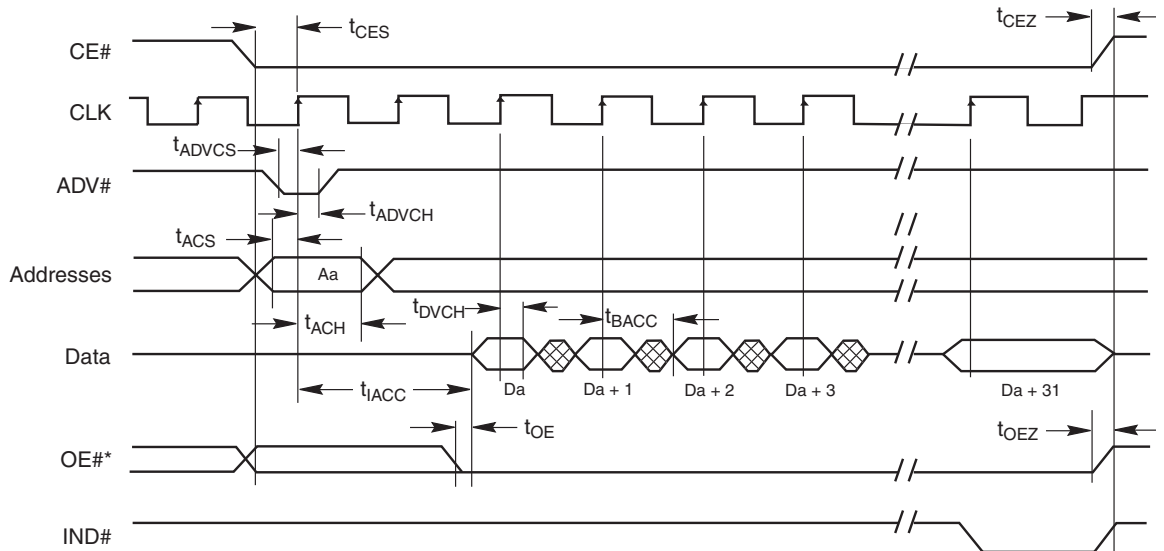

Figure 16. Burst Mode Read

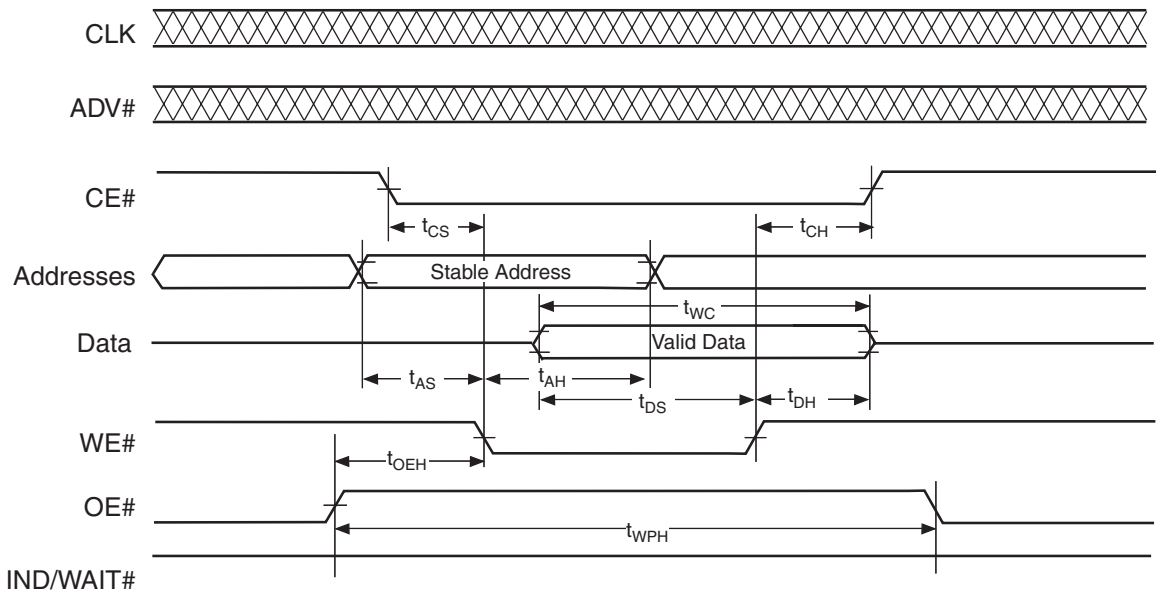
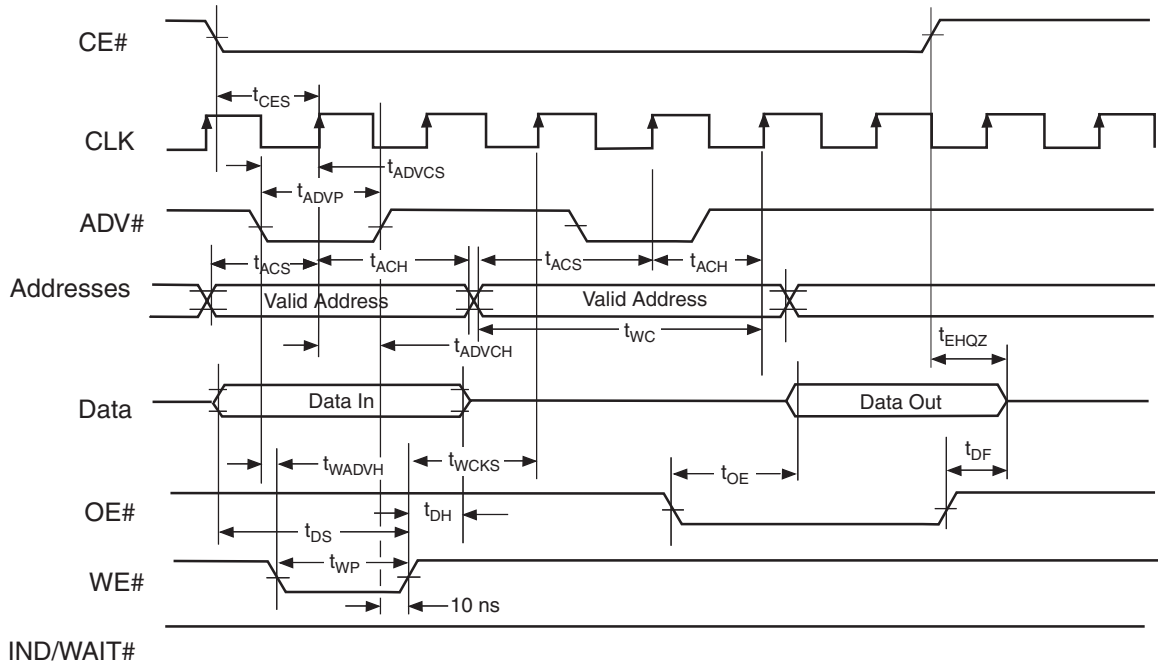

Figure 17. Asynchronous Command Write Timing

**Note:** All commands have the same number of cycles in both asynchronous and synchronous modes, including the READ/RESET command. Only a single array access occurs after the F0h command is entered. All subsequent accesses are burst mode when the burst mode option is enabled in the Configuration Register.



## AC Characteristics



**Figure 18. Synchronous Command Write/Read Timing**

**Note:** All commands have the same number of cycles in both asynchronous and synchronous modes, including the READ/RESET command. Only a single array access occurs after the F0h command is entered. All subsequent accesses are burst mode when the burst mode option is enabled in the Configuration Register.

## Hardware Reset (RESET#)

Parameter		Description	Test Setup	All Speed Options	Unit
JEDEC	Std.				
	$t_{READY}$	RESET# Pin Low (During Embedded Algorithms) to Read or Write (See Note)	Max	11	$\mu$ s
	$t_{READY}$	RESET# Pin Low (NOT During Embedded Algorithms) to Read or Write (See Note)	Max	500	ns
	$t_{RP}$	RESET# Pulse Width	Min	500	ns
	$t_{RH}$	RESET# High Time Before Read (See Note)	Min	50	ns
	$t_{RPD}$	RESET# Low to Standby Mode	Min	20	$\mu$ s
	$t_{RB}$	RY/BY# Recovery Time	Min	0	ns

**Note:** Not 100% tested.

## AC Characteristics

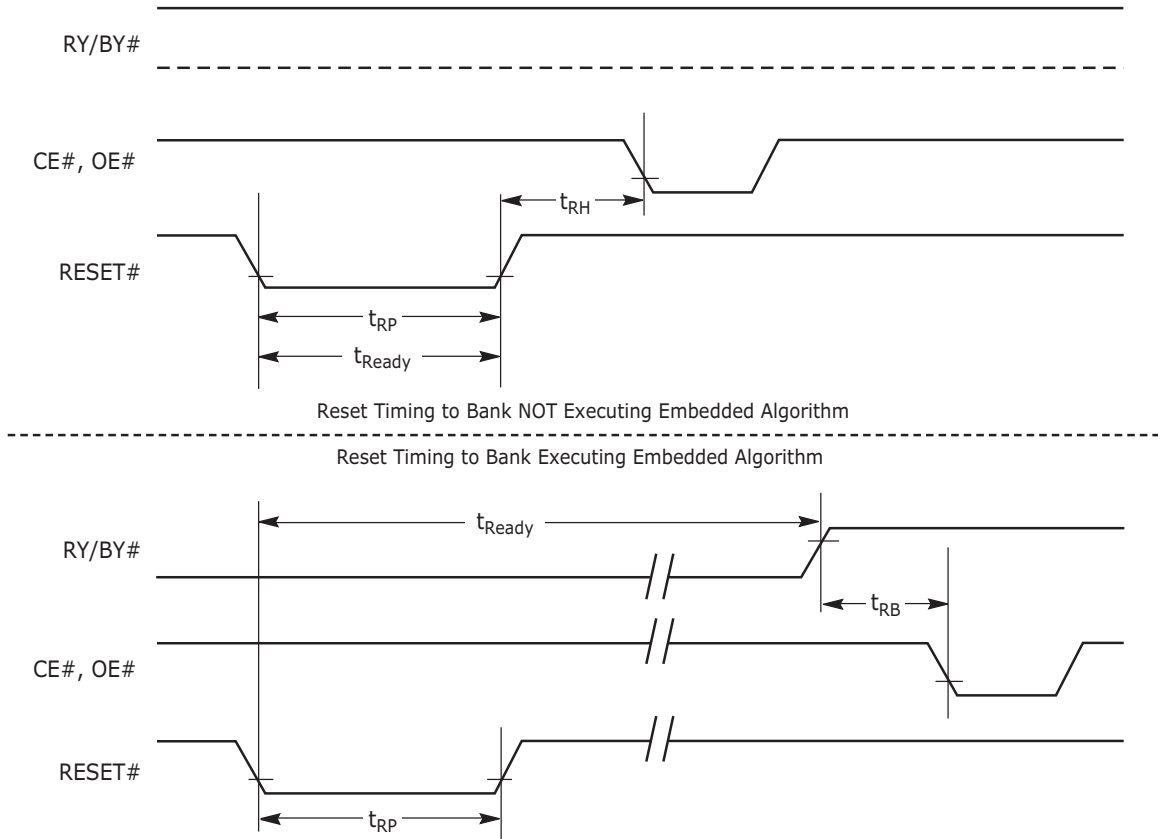

Figure 19. RESET# Timings

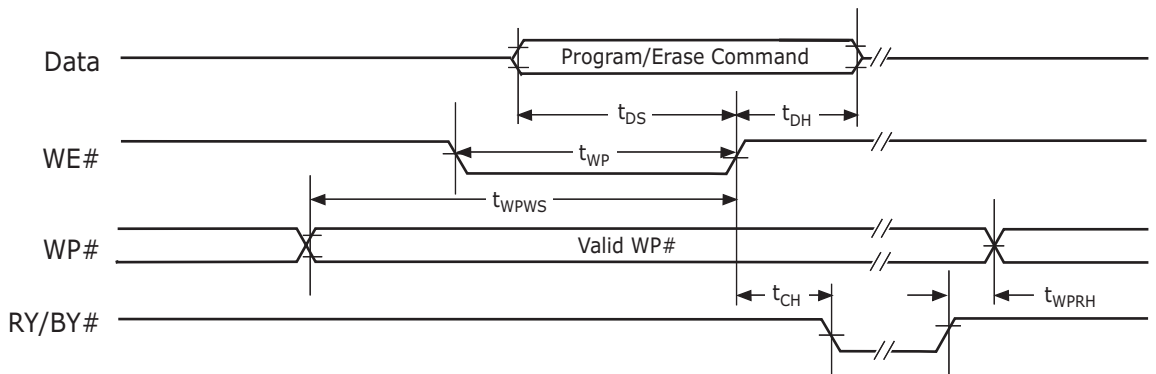

Figure 20. WP# Timing

# AC Characteristics

## Erase/Program Operations

Parameter		Description	All Speed Options		Unit	
JEDEC	Std.					
$t_{AVAV}$	$t_{WC}$	Write Cycle Time (Note 1)	Min	60	ns	
$t_{AVWL}$	$t_{AS}$	Address Setup Time	Min	0		
$t_{WLAX}$	$t_{AH}$	Address Hold Time	Min	25		
$t_{DVWH}$	$t_{DS}$	Data Setup to WE# Rising Edge	Min	18		
$t_{WHDX}$	$t_{DH}$	Data Hold from WE# Rising Edge	Min	2		
$t_{GHWL}$	$t_{GHWL}$	Read Recovery Time Before Write (OE# High to WE# Low)	Min	0		
$t_{ELWL}$	$t_{CS}$	CE# Setup Time	Min	0		
$t_{WHEH}$	$t_{CH}$	CE# Hold Time	Min	2		
$t_{WLWH}$	$t_{WP}$	WE# Width	Min	25		
$t_{WHWL}$	$t_{WPH}$	Write Pulse Width High	Min	30		
$t_{WHWH1}$	$t_{WHWH1}$	Programming Operation (Note 2)	Typ	18		$\mu$ s
$t_{WHWH2}$	$t_{WHWH2}$	Sector Erase Operation (Note 2)	Typ	1.0		sec.
	$t_{VCS}$	V <sub>CC</sub> Setup Time (Note 1)	Min	50		$\mu$ s
	$t_{RB}$	Recovery Time from RY/BY#	Min	0	ns	
	$t_{BUSY}$	RY/BY# Delay After WE# Rising Edge	Max	90		
	$t_{WPWS}$	WP# Setup to WE# Rising Edge with Command	Min	20		
	$t_{WPRH}$	WP# Hold after RY/BY# Rising Edge	Min	2		

**Notes:**

1. Not 100% tested.
2. See [Command Definitions](#) for more information.

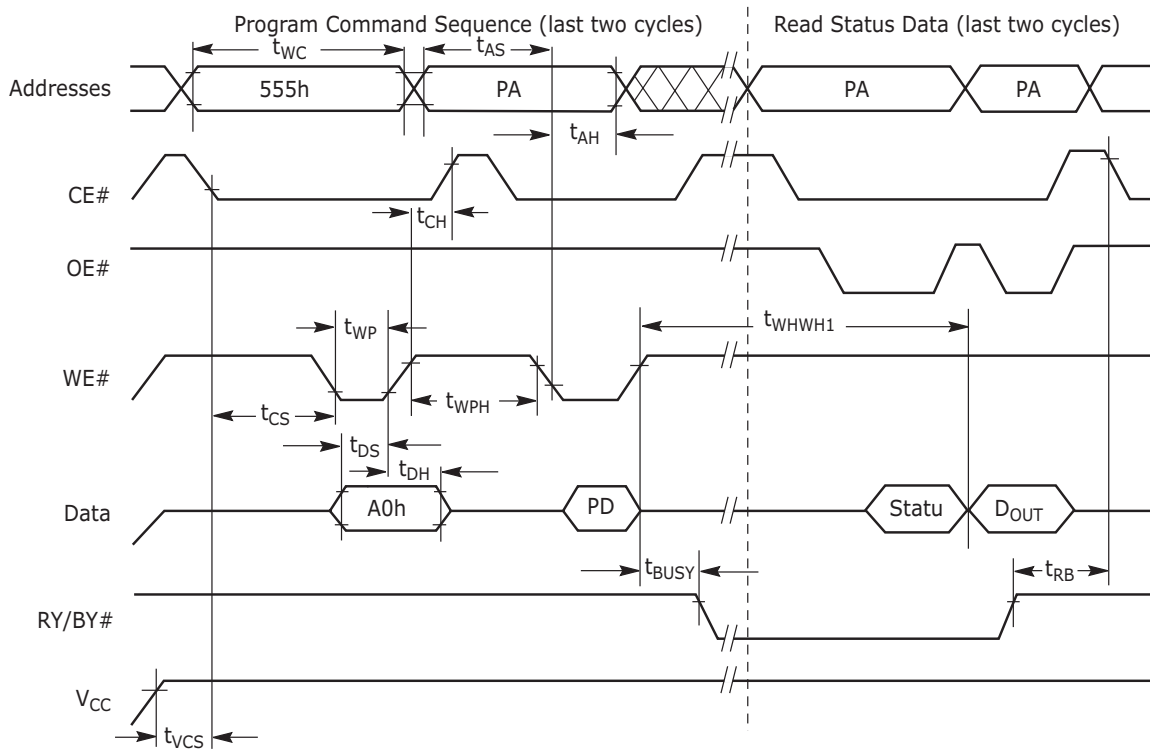

**Note:** PA = program address, PD = program data, D<sub>OUT</sub> is the true data at the program address.

## AC Characteristics

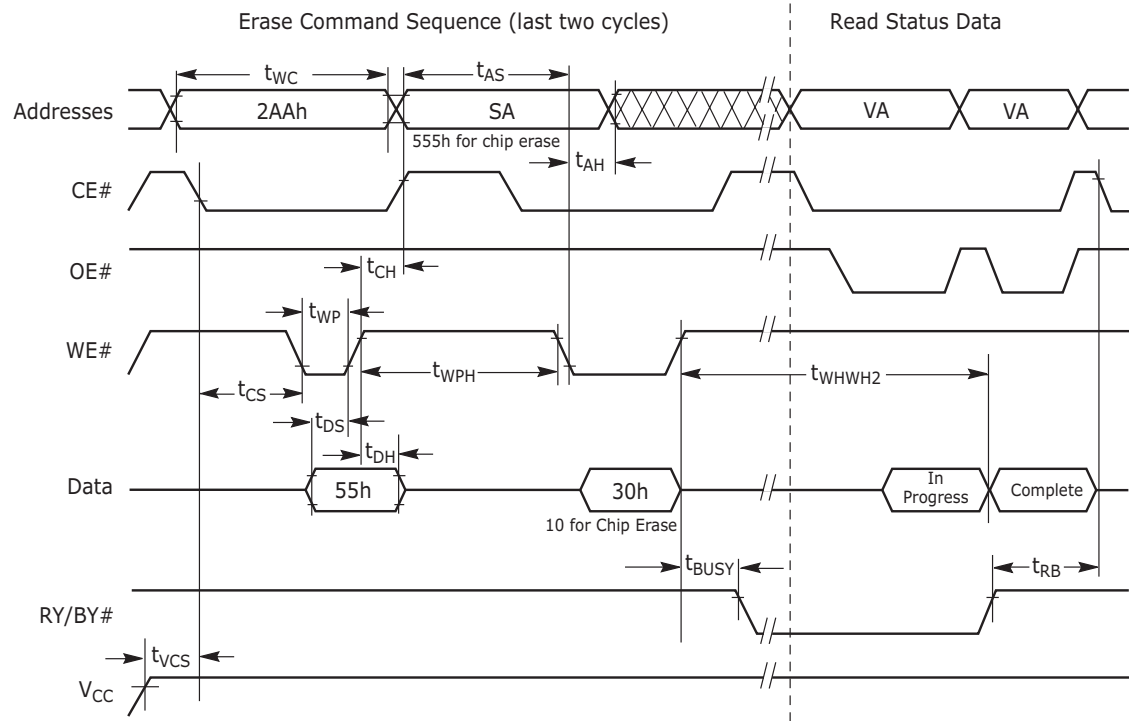

**Note:** SA = sector address (for Sector Erase), VA = Valid Address for reading status data (see [Write Operation Status](#)).

**Figure 21. Chip/Sector Erase Operation Timings**

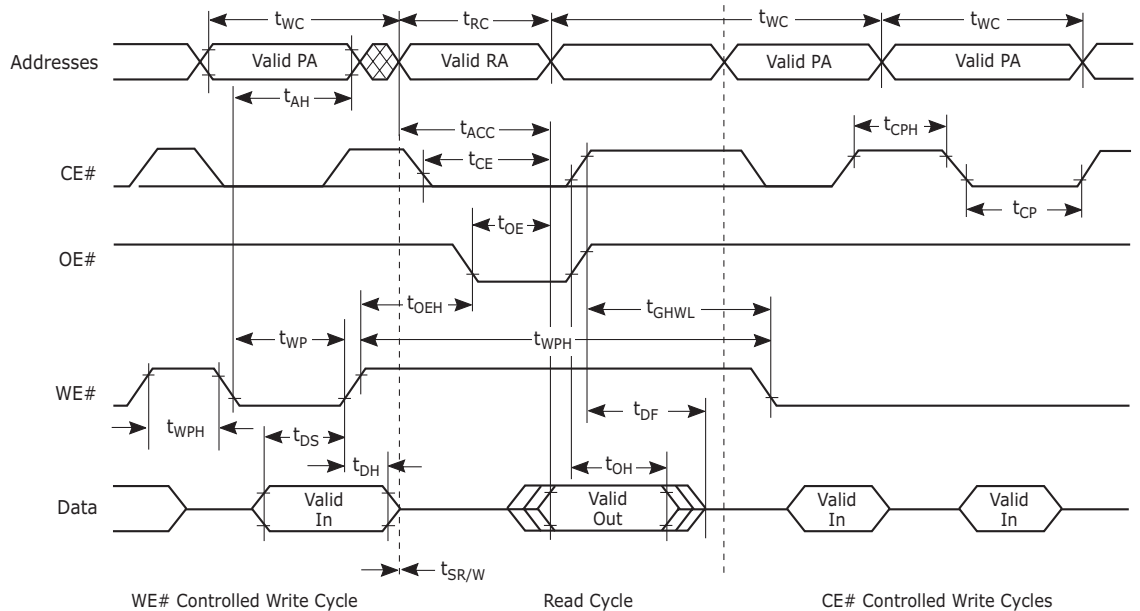

**Figure 22. Back-to-Back Cycle Timings**

## AC Characteristics

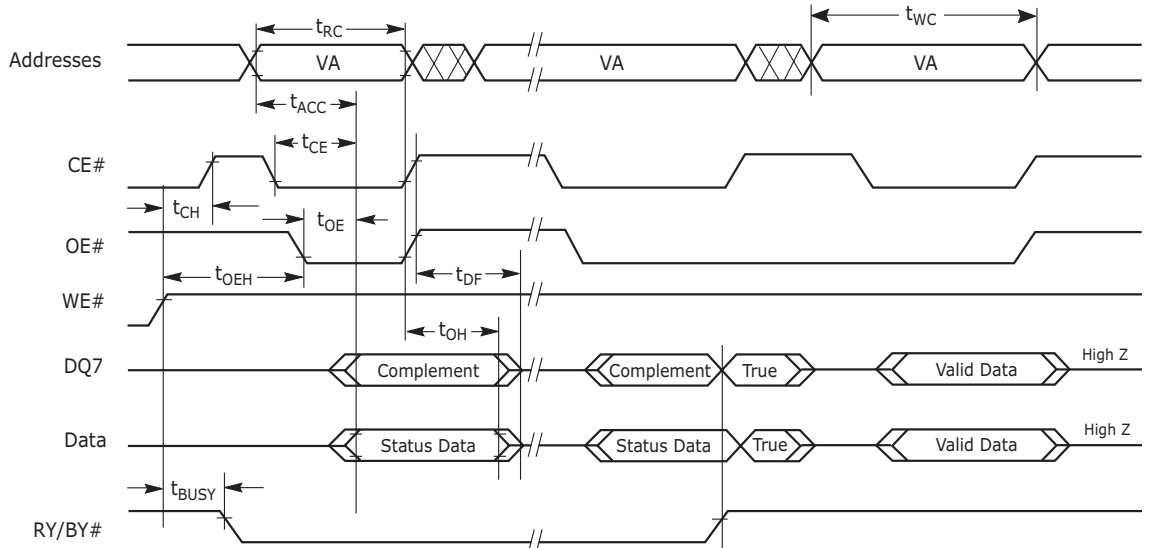

**Note:** VA = Valid address. Illustration shows first status cycle after command sequence, last status read cycle, and array data read cycle.

**Figure 23. Data# Polling Timings (During Embedded Algorithms)**

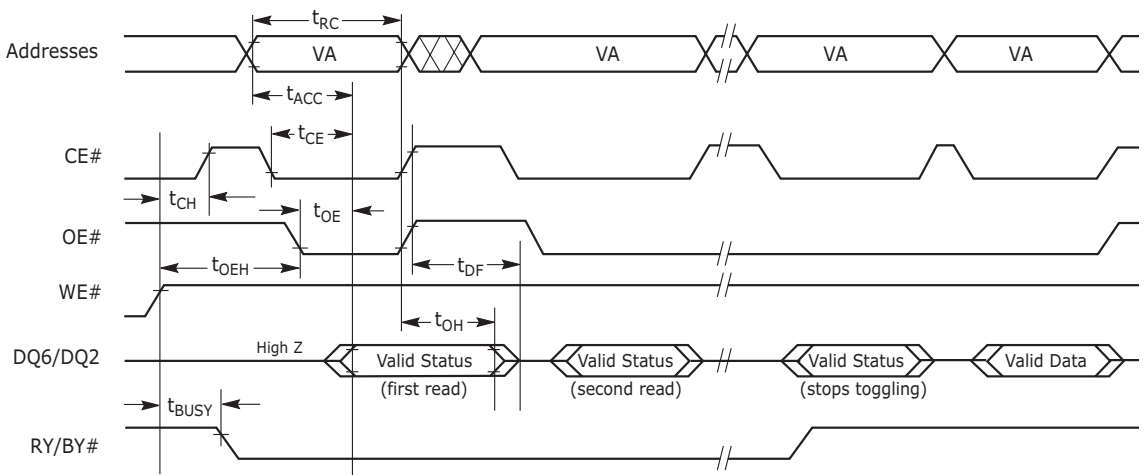

**Note:** VA = Valid address; not required for DQ6. Illustration shows first two status cycle after command sequence, last status read cycle, and array data read cycle.

**Figure 24. Toggle Bit Timings (During Embedded Algorithms)**

## AC Characteristics

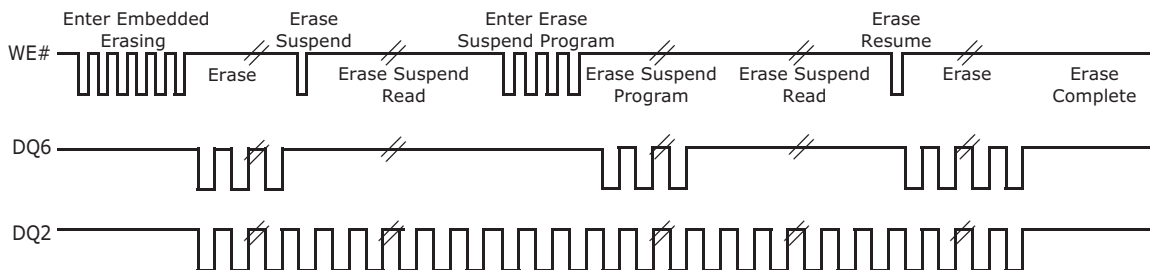

**Note:** The system may use CE# or OE# to toggle DQ2 and DQ6. DQ2 toggles only when read at an address within an erase-suspended sector.

**Figure 25. DQ2 vs. DQ6 for Erase/Erase Suspend Operations**

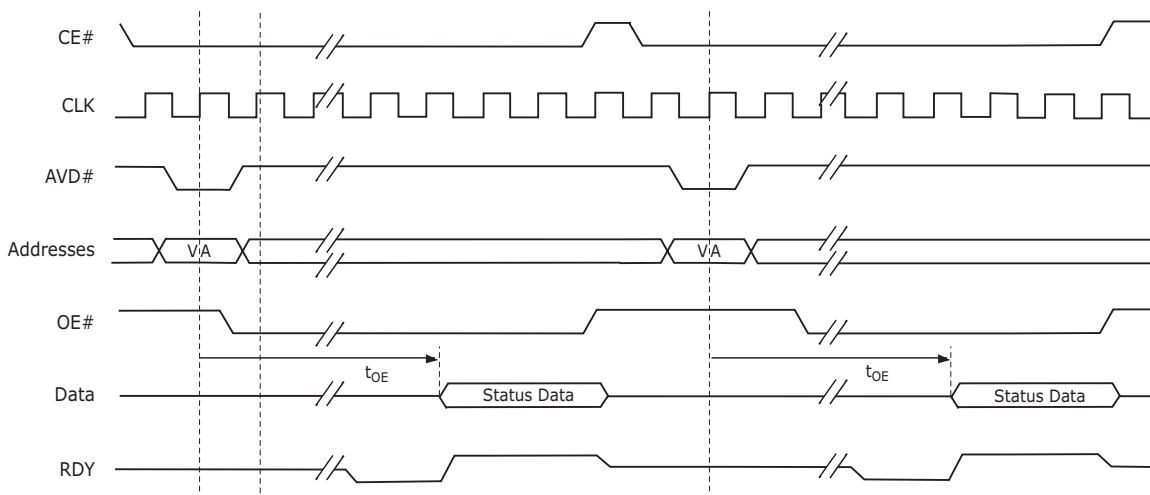

**Notes:**

1. The timings are similar to synchronous read timings and asynchronous data polling Timings/Toggle bit Timing.
2. VA = Valid Address. Two read cycles are required to determine status. When the Embedded Algorithm operation is complete, the toggle bits stop toggling.
3. RDY is active with data (A18 = 0 in the Configuration Register). When A18 = 1 in the Configuration Register, RDY is active one clock cycle before data.
4. Data polling requires burst access time delay.

**Figure 26. Synchronous Data Polling Timing/Toggle Bit Timings**

## AC Characteristics

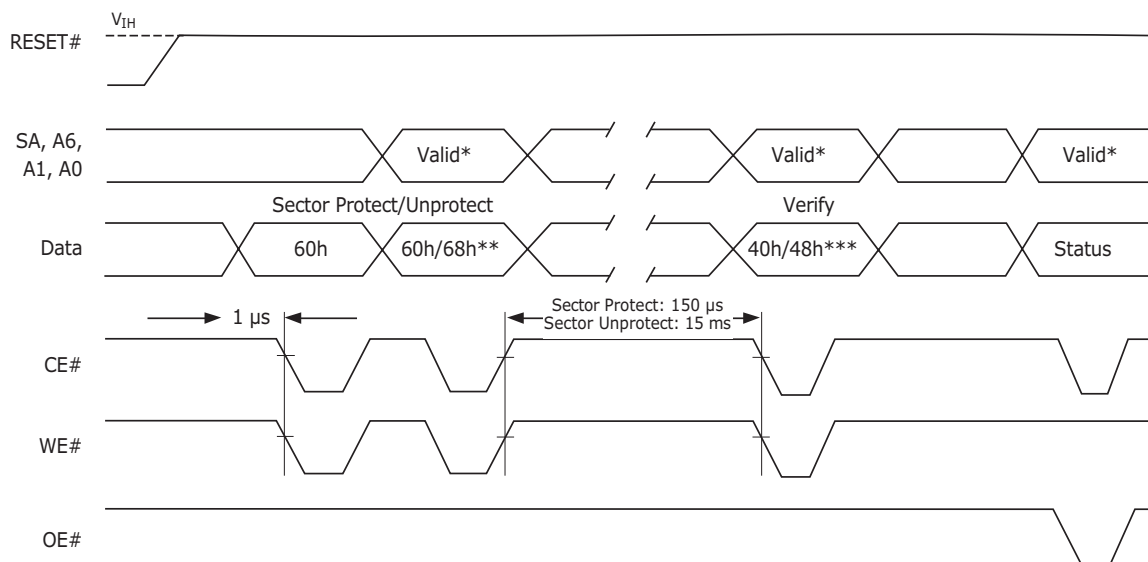

\* Valid address for sector protect: A[7:0] = 3Ah. Valid address for sector unprotect: A[7:0] = 3Ah.  
 \*\* Command for sector protect is 68h. Command for sector unprotect is 60h.  
 \*\*\* Command for sector protect verify is 48h. Command for sector unprotect verify is 40h.

Figure 27. Sector Protect/Unprotect Timing Diagram

## Alternate CE# Controlled Erase/Program Operations

Parameter		Description		All Speed Options	Unit
JEDEC	Std.				
$t_{AVAV}$	$t_{WC}$	Write Cycle Time (Note 1)	Min	65	ns
$t_{AVEL}$	$t_{AS}$	Address Setup Time	Min	0	
$t_{ELAX}$	$t_{AH}$	Address Hold Time	Min	45	
$t_{DVEH}$	$t_{DS}$	Data Setup Time	Min	35	
$t_{EHDX}$	$t_{DH}$	Data Hold Time	Min	2	
	$t_{OES}$	Output Enable Setup Time	Min		
$t_{GHLEL}$	$t_{GHLEL}$	Read Recovery Time Before Write (OE# High to WE# Low)	Min	0	
$t_{WLEL}$	$t_{WS}$	WE# Setup Time	Min		
$t_{EHWLH}$	$t_{WH}$	WE# Hold Time	Min		
	$t_{WP}$	WE# Width	Min	32	
$t_{ELEH}$	$t_{CP}$	CE# Pulse Width	Min	16	
$t_{EHEL}$	$t_{CPH}$	CE# Pulse Width High	Min	30	
$t_{WHWSH1}$	$t_{WHWH1}$	Programming Operation (Note 2)	Typ	18	
$t_{WHWH2}$	$t_{WHWH2}$	Sector Erase Operation (Note 2)	Typ	1	sec.

**Notes:**

1. Not 100% tested.
2. See [Command Definitions](#) for more information.

## AC Characteristics

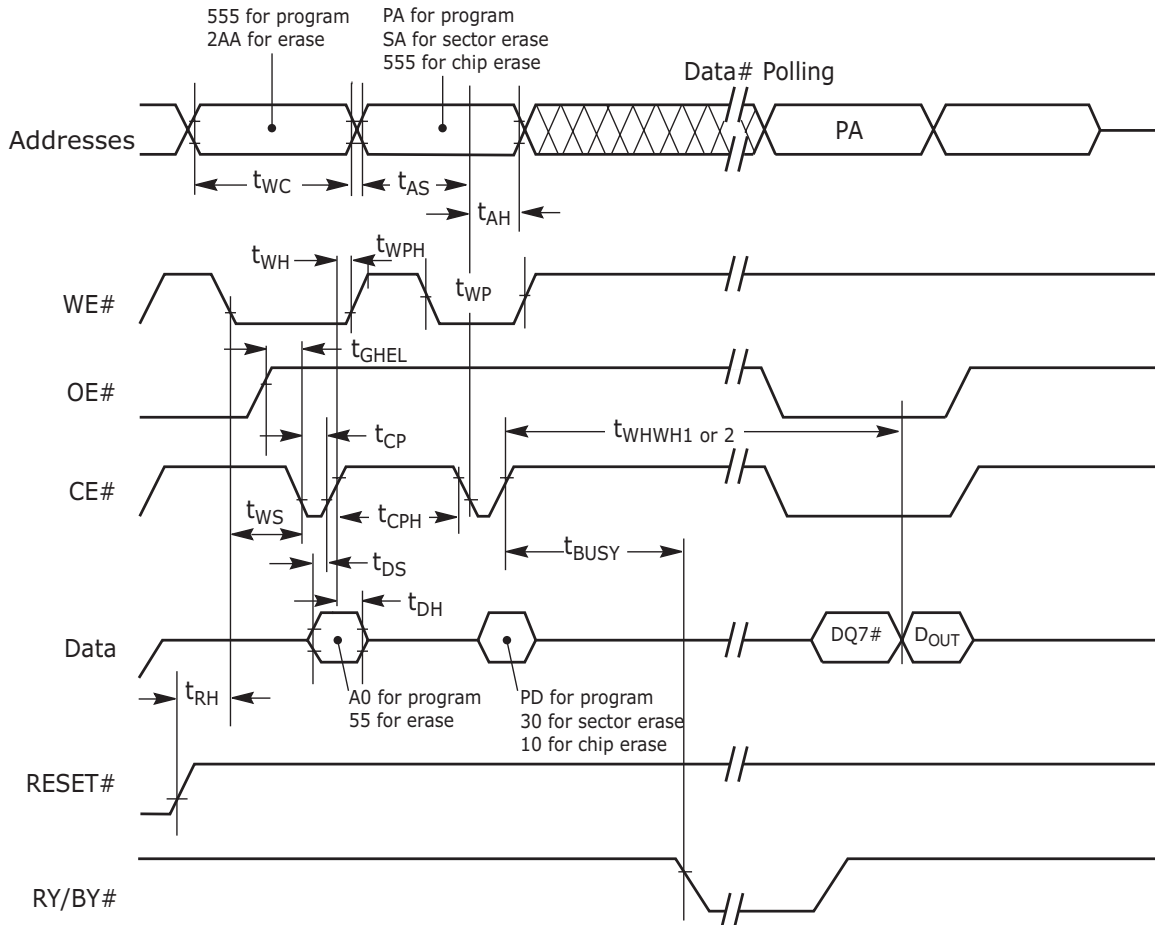

**Notes:**

1. PA = program address, PD = program data, DQ7# = complement of the data written to the device, D<sub>OUT</sub> = data written to the device.
2. Figure indicates the last two bus cycles of the command sequence.

**Figure 28. Alternate CE# Controlled Write Operation Timings**



## Erase and Programming Performance

Parameter	Typ (Note 1)	Max (Note 2)	Unit	Comments
Sector Erase Time	1.0	5	s	Excludes 00h programming prior to erasure (Note 4)
Chip Erase Time	16 Mb = 46 32 Mb = 78	16 Mb = 230 32 Mb = 460	s	
Double Word Program Time	18	250	μs	Excludes system level overhead (Note 5)
Accelerated Double Word Program Time	8	130	μs	
Accelerated Chip Program Time	16 Mb = 5 32 Mb = 10	16 Mb = 50 32 Mb = 100	s	
Chip Program Time (Note 3)	x32 16 Mb = 12 32 Mb = 24	16 Mb = 120 32 Mb = 240	s	

### Notes:

1. Typical program and erase times assume the following conditions: 25°C, 2.5 V  $V_{CC}$ , 100K cycles. Additionally, programming typicals assume checkerboard pattern.
2. Under worst case conditions of 145°C,  $V_{CC} = 2.5$  V, 1M cycles.
3. The typical chip programming time is considerably less than the maximum chip programming time listed.
4. In the pre-programming step of the Embedded Erase algorithm, all bytes are programmed to 00h before erasure.
5. System-level overhead is the time required to execute the two- or four-bus-cycle sequence for the program command. See [Table 41](#) and [Table 42](#) for further information on command definitions.
6. PPBs have a program/erase cycle endurance of 100 cycles.

## Latchup Characteristics

Description	Min	Max
Input voltage with respect to $V_{SS}$ on all pins except I/O pins (including A9, ACC, and WP#)	-1.0 V	12.5 V
Input voltage with respect to $V_{SS}$ on all I/O pins	-1.0 V	$V_{CC} + 1.0$ V
$V_{CC}$ Current	-100 mA	+100 mA

**Note:** Includes all pins except  $V_{CC}$ . Test conditions:  $V_{CC} = 3.0$  V, one pin at a time.

## PQFP and Fortified BGA Pin Capacitance

Parameter Symbol	Parameter Description	Test Setup	Typ	Max	Unit
$C_{IN}$	Input Capacitance	$V_{IN} = 0$	6	7.5	pF
$C_{OUT}$	Output Capacitance	$V_{OUT} = 0$	8.5	12	pF
$C_{IN2}$	Control Pin Capacitance	$V_{IN} = 0$	7.5	9	pF

### Notes:

1. Sampled, not 100% tested.
2. Test conditions  $T_A = 25^\circ\text{C}$ ,  $f = 1.0$  MHz.

## Revision Summary

### S29CD016G Revision History

#### Revision A1 (March 22, 2004)

##### Performance Characteristics

Burst Mode Read: changed to 66-MHz.

##### Ordering Information

Changed device number/description call out to show the two 16-Mbit configurations.

##### Table 12 and Table 13

Corrected which sectors report to which bank.

##### Asynchronous Read Operations Table

Removed the OR Speed option.

#### Revision A2 (May 24, 2004)

##### "Spansion" logo

Replaces AMD in bullet seven, first column.

##### Fujitsu MBM29LV and MBM129F

Added to bullet ten, first column.

##### Ultra Low Power Consumption Bullet

"capable of..." deleted from first bullet, second column.

##### Block diagram

Reset# moved, RY/BY added.

##### Simultaneous Read/Write Circuit Block Diagram

RY/BY added; Bank 1 added; Bank 0 added.

##### Pin Configuration

"A pull-up resistor of 10k..." added to RY/BY#.

##### Ordering Information

Additional ordering options updated to "protects sectors 44 and 45".

##### Device Number/Description

Bit description altered.

##### Simultaneous Read/Write Operation With Zero Latency

Table 3 and 4 Bank # change.

##### Auto Select Mode

Table 5: Manufacturer ID Row updated (A3, A2).

Table 5: DQ7 to DQ0 Column updated.

### **Linear Burst Read Operations**

Table 6: "(x16)" removed from header row.

### **IND/Wait# Operation in Linear Mode**

Figure 2 - "Address 2" removed.

### **Initial Burst Access Delay Control**

Figure 3 - Valid Address line changed.

Notes - Clock cycles updated.

### **Configuration Register**

Table 9: CR14 reserve bit assigned ASD.

Table 9: Speed options changed.

Table 10: CR14 reserve changed to ASD.

### **Table 12. Sector Addresses for Ordering Option 00**

Bank changed to 0.

Bank changed to 1.

### **Table 13. Sector Addresses for Ordering Option 01**

Bank changed to 0.

Bank changed to 1.

### **Table 16. Device Geometry Definition**

0005 = supports x16 and x32 via WORD#..." Removed.

### **Unlock Bypass Command Sequence**

Table "18" replaced with "19" in text.

### **Table 19. Memory Array Command Definitions (x32 Mode)**

Autoselect (7) - Device ID (11); Fifth/Data changed to "36".

### **Table 20. Sector Protection Command Definitions (x32 Mode)**

PBB Status (11,12) Third/Addr changed to "SG". PPB Lock Bit Status; Third/Addr "BA" removed. DYB Status; Third/Addr changed to "SA".

### **Absolute Maximum Ratings**

Address, Data... changed to 3.6v.

### **Table 22 CMOS Compatible**

Input High Voltage Max changed to 3.6. RY/BY#, Output Low Current Min removed, Max added (8).

### **Table 23. Test Specifications**

Test conditions changed to OJ,OM,OP.

### **AC Characteristics**

Figure 14 updated RESET#.

**Table number 24. Asynchronous Read Operations**

OM speed options; Output Enable to Output Delay "20" added.

**Table 26. Hardware Reset**

Last row deleted.

**Erase/Program Operations**

TWADVH row added. TWCKS row added.

**Table 27. Alternate CE# Controlled Erase/Program Operations**

TWPH row added, TWADVH row added, TWCKS row added.

**Physical Dimensions**

Latchup characteristics deleted.

**Pin Description**

"WAIT# Provides data valid feedback only when the burst length is set to continuous." Removed from document.

**Revision A3 (May 26, 2004)**

**Block Diagram on page 6**

Moved RESET# to point to the State Control/Command Register.

**Figure 2, on page 22**

Updated note added "Double-Word" to figure title.

**Table 9, "Configuration Register Definitions," on page 24**

Added "CR14 = Automatic Sleep Mode..." configurations.

**Table 1, "Sector Addresses for Ordering Option 00," on page 33**

Re-inserted previously missing data.

Removed "Note 1" from Sector SA1.

Added "Note 3" to Sector SA44 and SA45.

Moved Sectors SA15 - SA30 to Bank 1.

**Table on page 35**

Added "Note 3" to Sector SA45.

**Revision A4 (November 5, 2004)**

**Global**

Added reference links

Added Colophon

Updated Trademark

**Product Selector Guide**

Removed note from Product Selector Guide table

**Block Diagram**

Changed text on Input/Output buffers to show DQ0 to DQ31

**Pin Configuration**

Changed text in ACC description

**Accelerated Program and Erase Operations**

Changed text in this paragraph

**Table 5**

Change Address text column.

**SecSi Sector Entry Command**

Changed address text in this paragraph

**Figure 18**

Changed time spec call out from 10 ns to  $t_{WADVH2}$

**Table 27**

Added new row for  $t_{WADVH2}$

**Rev History Family Data sheet Rev A (July 18, 2005)****Global**

Merged S29CD016G and S29CD032G datasheets into one family CD-G datasheet

Changed datasheet status to "Preliminary Information"

Added in 75MHz parameters

**Ordering Information**

Model numbers (character 15th & 16th) changed to reflect mask revision, autoselect code and top/bottom boot

Added GT Grade under Temperature Range and Quality Grade

Added note to "Refer to the KGD Datasheet supplement for die/wafer sales"

**Product Selector Guide**

Changed Min. Initial clock Delay values

**Memory Map and Sector Protect Groups**

Modified Notes 1 & 3

Add in Note 4

**Simultaneous Read/Write Operation**

Removed Table 2: Bank Assignment for Boot Bank Sector Device

Removed Table 3: Ordering Option 00

Removed Table 4: Ordering Option 01

**Secured Silicon Sector**

Added in Electronic Marking

**Common Flash Memory Interface**

Updated website to reflect Spansion.com

Changed address 28h from 0003h to 0005h

**Command Definitions**

Remove Secured Silicon Protection Bit Program command

**Absolute Maximum Ratings**

Changed Overshoot/Undershoot to be  $\pm 0.7V$  from  $\pm 2.0V$

Changed Address, Data, Control Signals to  $-0.5V$  to  $3V$  for 16Mb

**Operating Ranges**

Changed VIO to 1.65V to 3.6V

**Burst Mode Read for 32Mb & 16 Mb**

Changed tADVCS = 5.75ns for 75MHz

Changed tADVCH to be 2ns for 66MHz, 56MHz, 40 MHz

Changed tIACC values

Rounded tCLK values

Changed tCR to tCLKR

Changed tCF to tCLKF

Changed tCL to tCLKL

Changed tCH to tCLKH and changed values

Removed tDS, tDH, tAS, tAH, tCS

Added tWADVH, tWCKS

**Erase/Program Operations**

Removed tWCKS

**Alternative CE# Controlled Erase/Program Operations**

Added tWADVH

Added tWCKS

**Rev History Family Datasheet Rev B0 (November 14, 2005)****Absolute Maximum Ratings**

Changed under/overshoot to  $\pm 2.0V$

Changed Vcc, VIO values

Changed Address, Data, Control Signal values

Note 5 & 6

**Revision History**

Added in previous revision histories.

**Erase/Program Operations**

Added Note 1 to tWC and tVCS

**Global**

Changed SecSi to Secured Silicon.

**Colophon**

The products described in this document are designed, developed and manufactured as contemplated for general use, including without limitation, ordinary industrial use, general office use, personal use, and household use, but are not designed, developed and manufactured as contemplated (1) for any use that includes fatal risks or dangers that, unless extremely high safety is secured, could have a serious effect to the public, and could lead directly to death, personal injury, severe physical damage or other loss (i.e., nuclear reaction control in nuclear facility, aircraft flight control, air traffic control, mass transport control, medical life support system, missile launch control in weapon system), or (2) for any use where chance of failure is intolerable (i.e., submersible repeater and artificial satellite). Please note that Spansion will not be liable to you and/or any third party for any claims or damages arising in connection with above-mentioned uses of the products. Any semiconductor device has an inherent chance of failure. You must protect against injury, damage or loss from such failures by incorporating safety design measures into your facility and equipment such as redundancy, fire protection, and prevention of over-current levels and other abnormal operating conditions. If any products described in this document represent goods or technologies subject to certain restrictions on export under the Foreign Exchange and Foreign Trade Law of Japan, the US Export Administration Regulations or the applicable laws of any other country, the prior authorization by the respective government entity will be required for export of those products.

**Trademarks and Notice**

The contents of this document are subject to change without notice. This document may contain information on a Spansion LLC product under development by Spansion LLC. Spansion LLC reserves the right to change or discontinue work on any product without notice. The information in this document is provided as is without warranty or guarantee of any kind as to its accuracy, completeness, operability, fitness for particular purpose, merchantability, non-infringement of third-party rights, or any other warranty, express, implied, or statutory. Spansion LLC assumes no liability for any damages of any kind arising out of the use of the information in this document.

Copyright ©2004-2005 Spansion LLC. All rights reserved. Spansion, the Spansion logo, and MirrorBit are trademarks of Spansion LLC. Other company and product names used in this publication are for identification purposes only and may be trademarks of their respective companies.