

**FEATURES**

- Can Replace Expensive High Frequency Oscillator
- Mask Programmable Analog Phase Locked Loop
- Low Power Single Supply 5 V or 3.3 V CMOS Technology
- 8 Pin DIP or SOIC Package
- Crystal Oscillator Circuit On Board

**GENERAL DESCRIPTION**

The ST49C101A-XX is a mask programmable monolithic analog CMOS device, designed to replace existing high frequency crystal/oscillator with single low frequency crystal. The ST49C101A-XX provides high speed and low jitter clock output.

The ST49C101A-XX is designed in a CMOS process to achieve up to 150 MHz speed for high end frequencies.

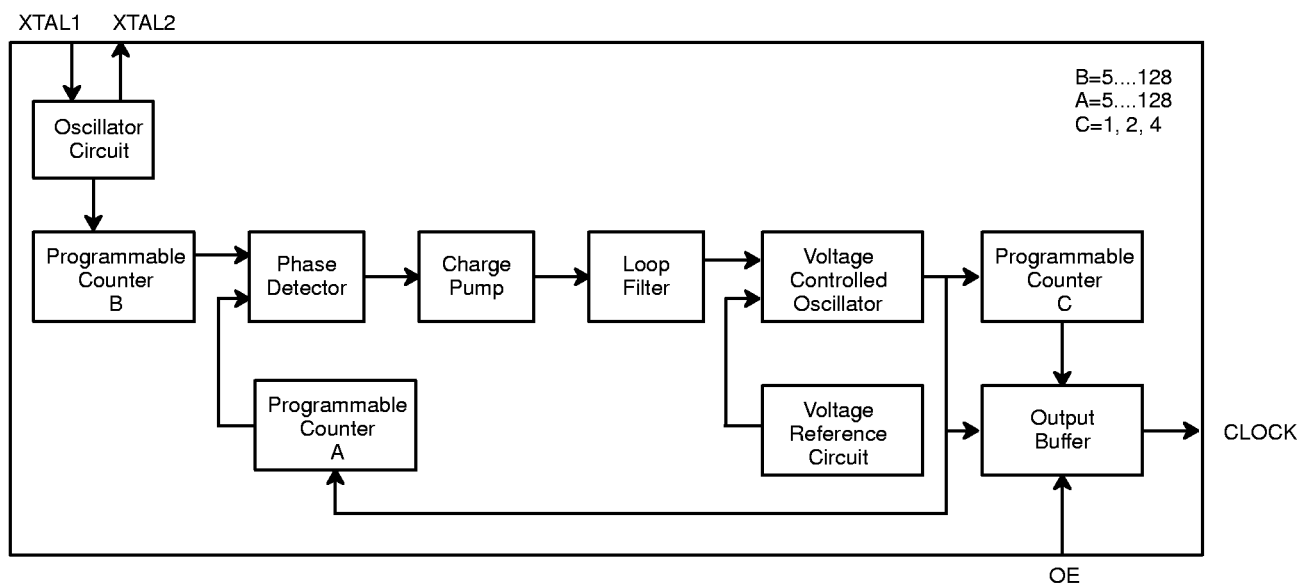
**ORDERING INFORMATION**

Part No.	Package	Operating Temperature Range
ST49C101ACP8-XX <sup>1</sup>	8 Lead 300 Mil PDIP	0°C to 70°C
ST49C101ACF8-XX <sup>1</sup>	8 Lead 150 Mil Jedec SOIC	0°C to 70°C

**Notes**

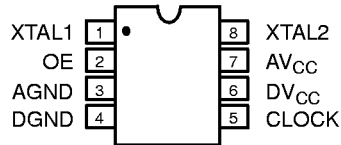
<sup>1</sup>“XX” See option table on page 5 (Table 1.)

**BLOCK DIAGRAM**

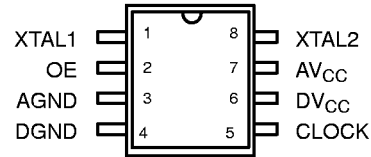


**Figure 1. Block Diagram**

## PIN CONFIGURATION



**8 Lead PDIP (0.300")**



**8 Pin SOIC (Jedec, 0.150")**

## PIN DESCRIPTION

Pin #	Symbol	Type	Description
1	XTAL1	I	Crystal or External Clock input. A crystal can be connected to this pin and XTAL2 pin to generate internal phase locked loop reference clock. For external clock, XTAL2 is left open or used as buffered clock output.
2 <sup>1</sup>	OE	I	Clock Output Enable (Active high). CLOCK output is three stated when this pin is low.
3	AGND	O	Analog ground.
4	DGND	O	Digital ground.
5	CLOCK	O	Programmed output clock.
6	DV <sub>CC</sub>	I	Positive supply voltage. Single +5 or 3.3 volts.
7	AV <sub>CC</sub>	I	Analog supply voltage. Single +5 or 3.3 volts.
8	XTAL2	O	Crystal output.

### Notes

<sup>1</sup>Has internal pull-up resistor

## DC ELECTRICAL CHARACTERISTICS

Test Conditions:  $T_A = 0$  to  $70^\circ\text{C}$ ,  $V_{CC} = 5.0\text{V} \pm 10\%$  Unless Otherwise Specified

SYMBOL	PARAMETER	MIN	TYP	MAX	UNIT	CONDITIONS
$V_{IL}$	Input low level			0.8	V	
$V_{IH}$	Input high level	2.0			V	
$V_{OL}$	Output low level			0.5	V	$I_{OL} = 8.0$ mA
$V_{OH}$	Output high level	2.8			V	$I_{OH} = 8.0$ mA
$I_{IL}$	Input low current			-100	$\mu\text{A}$	Pin 2 only
$I_{IH}$	Input high current			1	$\mu\text{A}$	$V_{IN}=V_{CC}$ Pin 2
$I_{CC}$	Operating current		35	50	mA	No load. CLOCK=100MHz
$R_{IN}$	Input pull-up resistance	50	75	100	k $\Omega$	

## AC ELECTRICAL CHARACTERISTICS

Test Conditions:  $T_A = 0$  to  $70^\circ\text{C}$ ,  $V_{CC} = 5.0\text{V} \pm 10\%$  Unless Otherwise Specified

SYMBOL	PARAMETER	MIN	TYP	MAX	UNIT	CONDITIONS
$T_{1,2}$	CLOCK rise/fall time		1.5	3	ns	Load=30 pF, $0.2 V_{CC} - 0.8 V_{CC}$
$T_4$	Duty cycle	45	50	55	%	$V_{CC}/2$ switch point up to 100 MHz, Load = 20 pF
$T_5$	Duty cycle	45	50	55	%	$V_{CC}/2$ switch point 100–150 MHz, 95 $\Omega$ (AC Terminated)
$T_3$	Jitter 1 sigma		$\pm 0.4$	$\pm 1$	%	of period
$T_3$	Jitter absolute		$\pm 1$	$\pm 3$	%	of period
$T_{IN}$	Input reference frequency	12	20	30	MHz	
$T_{OUT}$	Output frequency	50		150	MHz	ST49C101A-05
$T_{OUT}$	Output frequency	50		120	MHz	ST49C101A-06
$T_{OUT}$	Output frequency	25		80	MHz	ST49C101A-07, -08

## DC ELECTRICAL CHARACTERISTICS

Test Conditions:  $T_A = 0$  to  $70^\circ\text{C}$ ,  $V_{CC} = 3.3\text{V} \pm 10\%$  Unless Otherwise Specified

SYMBOL	PARAMETER	MIN	TYP	MAX	UNIT	CONDITIONS
$V_{IL}$	Input low level			0.8	V	
$V_{IH}$	Input high level	2.0			V	
$V_{OL}$	Output low level			0.5	V	$I_{OL} = 4.0$ mA
$V_{OH}$	Output high level	2.0			V	$I_{OH} = 4.0$ mA
$I_{IL}$	Input low current			-100	$\mu\text{A}$	Pin 2 only
$I_{IH}$	Input high current			1	$\mu\text{A}$	$V_{IN}=V_{CC}$ Pin 2
$I_{CC}$	Operating current		22	40	mA	No load. CLOCK=100 MHz
$R_{IN}$	Input pull-up resistance	50	75	100	k $\Omega$	

## AC ELECTRICAL CHARACTERISTICS

Test Conditions:  $T_A = 0$  to  $70^\circ\text{C}$ ,  $V_{CC} = 3.3\text{V} \pm 10\%$  Unless Otherwise Specified

SYMBOL	PARAMETER	MIN	TYP	MAX	UNIT	CONDITIONS
$T_{1,2}$	CLOCK rise/fall time		2	4	ns	Load=30 pF, $0.2 V_{CC} - 0.8 V_{CC}$
$\frac{T_4}{T_4 + T_5}$	Duty cycle	45	50	55	%	$V_{CC}/2$ switch point up to 100 MHz, Load = 30 pF
$\frac{T_4}{T_4 + T_5}$	Duty cycle	45	50	55	%	$V_{CC}/2$ switch point 100–150 MHz, $95\Omega$ (AC Terminated)
$T_3$	Jitter 1 sigma		$\pm 0.4$	$\pm 1$	%	of period
$T_3$	Jitter absolute		$\pm 1$	$\pm 3$	%	of period
$T_{IN}$	Input reference frequency	12	20	30	MHz	
$T_{OUT}$	Output frequency	50		140	MHz	ST49C101A-05
$T_{OUT}$	Output frequency	50		120	MHz	ST49C101A-06
$T_{OUT}$	Output frequency	25		70	MHz	ST49C101A-07, -08

Specifications are subject to change without notice

## ABSOLUTE MAXIMUM RATINGS

Supply Range ..... 7 Volts  
 Voltage at Any Pin ..... GND-0.3V to  $V_{CC} + 0.3\text{V}$

Operating Temperature .....  $0^\circ\text{C}$  to  $+70^\circ\text{C}$   
 Storage Temperature .....  $-40^\circ\text{C}$  to  $+150^\circ\text{C}$   
 Package Dissipation ..... 500 mW

**EXTERNAL CLOCK CONNECTION**

To minimize the noise pickup, it is recommended to connect 0.047µF capacitor to XTAL1, and keep the lead length of the capacitor to XTAL1 to a minimum to reduce noise susceptibility.

**FREQUENCY SELECT CALCULATION**

The ST49C101A-XX contains an analog phase locked loop circuit with digital closed loop dividers and a final output divider to achieve the desired dividing ratios for the clock output.

The accuracy of the frequencies produced by the ST49C101A-XX depends on the input frequency and divider ratios. The formula for calculating the exact output frequency is as follows (See Table 1.):

$$OutputClock = Factor \times Input Frequency$$

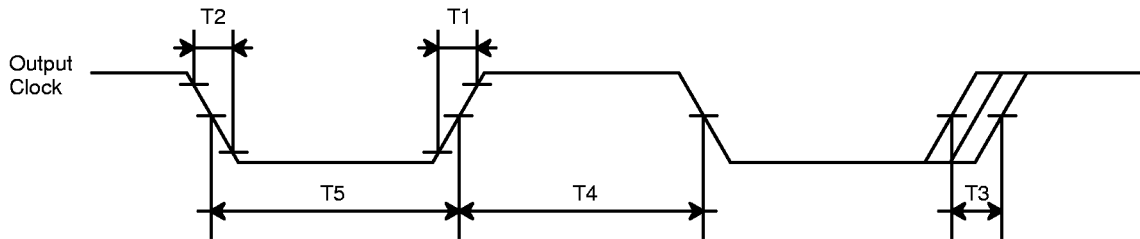
**Preprogrammed Options**

ST49C101A-XX	Factor	Max. Output Frequency <sup>1</sup>
ST49C101A-01	12	90 MHz
ST49C101A-02	6	90 MHz
ST49C101A-03	8	150 MHz
ST49C101A-04	4	90 MHz
ST49C101A-05	6	150 MHz
ST49C101A-06	4	120 MHz
ST49C101A-07	3	80 MHz
ST49C101A-08	2	80 MHz

**Notes**

<sup>1</sup>See AC electrical characteristics for max. frequency.

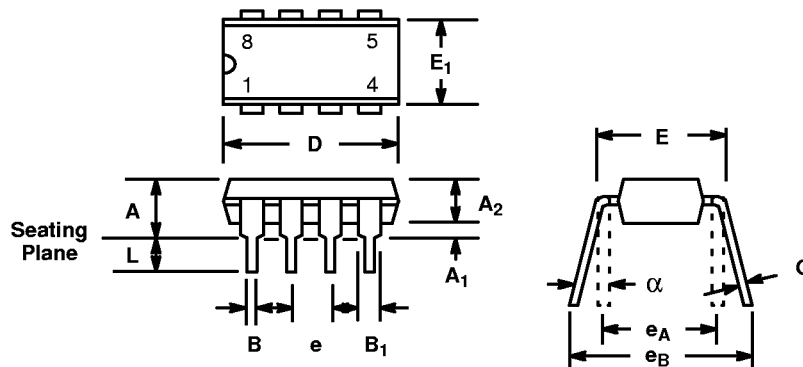
**Table 1. Options Selection**



**Figure 2. Timing Diagram**

## 8 LEAD PLASTIC DUAL-IN-LINE (300 MIL PDIP)

Rev. 1.00

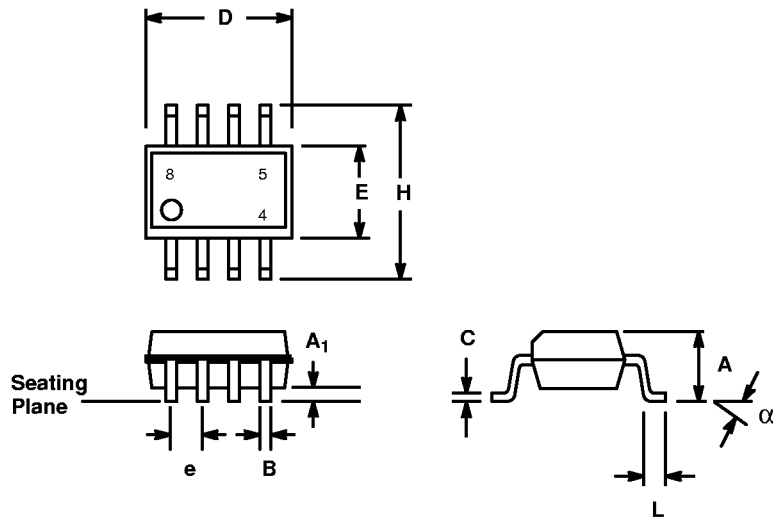


SYMBOL	INCHES		MILLIMETERS	
	MIN	MAX	MIN	MAX
A	0.145	0.210	3.68	5.33
A <sub>1</sub>	0.015	0.070	0.38	1.78
A <sub>2</sub>	0.015	0.195	2.92	4.95
B	0.014	0.024	0.36	0.56
B <sub>1</sub>	0.030	0.070	0.76	1.78
C	0.008	0.014	0.20	0.38
D	0.348	0.430	8.84	10.92
E	0.300	0.325	7.62	8.26
E <sub>1</sub>	0.240	0.280	6.10	7.11
e	0.100 BSC		2.54 BSC	
e <sub>A</sub>	0.300 BSC		7.62 BSC	
e <sub>B</sub>	0.310	0.430	7.87	10.92
L	0.115	0.160	2.92	4.06
α	0°	15°	0°	15°

Note: The control dimension is the inch column

**8 LEAD SMALL OUTLINE  
(150 MIL JEDEC SOIC)**

*Rev. 1.00*



SYMBOL	INCHES		MILLIMETERS	
	MIN	MAX	MIN	MAX
A	0.053	0.069	1.35	1.75
A <sub>1</sub>	0.004	0.010	0.10	0.25
B	0.013	0.020	0.33	0.51
C	0.007	0.010	0.19	0.25
D	0.189	0.197	4.80	5.00
E	0.150	0.157	3.80	4.00
e	0.050 BSC		1.27 BSC	
H	0.228	0.244	5.80	6.20
L	0.016	0.050	0.40	1.27
α	0°	8°	0°	8°

*Note: The control dimension is the millimeter column*

## NOTICE

EXAR Corporation reserves the right to make changes to the products contained in this publication in order to improve design, performance or reliability. EXAR Corporation assumes no responsibility for the use of any circuits described herein, conveys no license under any patent or other right, and makes no representation that the circuits are free of patent infringement. Charts and schedules contained here in are only for illustration purposes and may vary depending upon a user's specific application. While the information in this publication has been carefully checked; no responsibility, however, is assumed for inaccuracies.

EXAR Corporation does not recommend the use of any of its products in life support applications where the failure or malfunction of the product can reasonably be expected to cause failure of the life support system or to significantly affect its safety or effectiveness. Products are not authorized for use in such applications unless EXAR Corporation receives, in writing, assurances to its satisfaction that: (a) the risk of injury or damage has been minimized; (b) the user assumes all such risks; (c) potential liability of EXAR Corporation is adequately protected under the circumstances.

Copyright 1996 EXAR Corporation  
Datasheet February 1997

Reproduction, in part or whole, without the prior written consent of EXAR Corporation is prohibited.