



Integrated Device Technology, Inc.

**IDT79R3081  
RISController™**

**IDT 79R3081™, 79R3081E  
IDT 79R3081L, 79R3081LE**

T-49-17-38

**FEATURES**

- Instruction set compatible with IDT79R3000A, R3051, and R3500 RISC CPUs
- High level of integration minimizes system cost
  - R3000A Compatible CPU
  - R3010A Compatible Floating Point Accelerator
  - Optional R3000A compatible MMU
  - Large Instruction Cache
  - Large Data Cache
  - Read/Write Buffers
- 35 VUPS at 40MHz
  - 64,000 Dhrystones
  - 11 MFlops
- Flexible bus interface allows simple, low cost designs
- Optional 1x or 2x clock input
- 20 through 40MHz operation
- "L" version operates at 3.3V

- Large on-chip caches with user configurability
  - 16kB Instruction Cache, 4kB Data Cache
  - Dynamically configurable to 8kB Instruction Cache, 8kB Data Cache
  - Parity protection over data and tag fields
- Low cost 84-pin packaging
- Superset pin- and software-compatible with R3051
- Multiplexed bus interface with support for low-cost, low-speed memory systems with a high-speed CPU
- On-chip 4-deep write buffer eliminates memory write stalls
- On-chip 4-deep read buffer supports burst or simple block reads
- On-chip DMA arbiter
- Hardware-based Cache Coherency Support
- Programmable power reduction mode
- Bus Interface can operate at half-processor frequency

**R3081 BLOCK DIAGRAM**

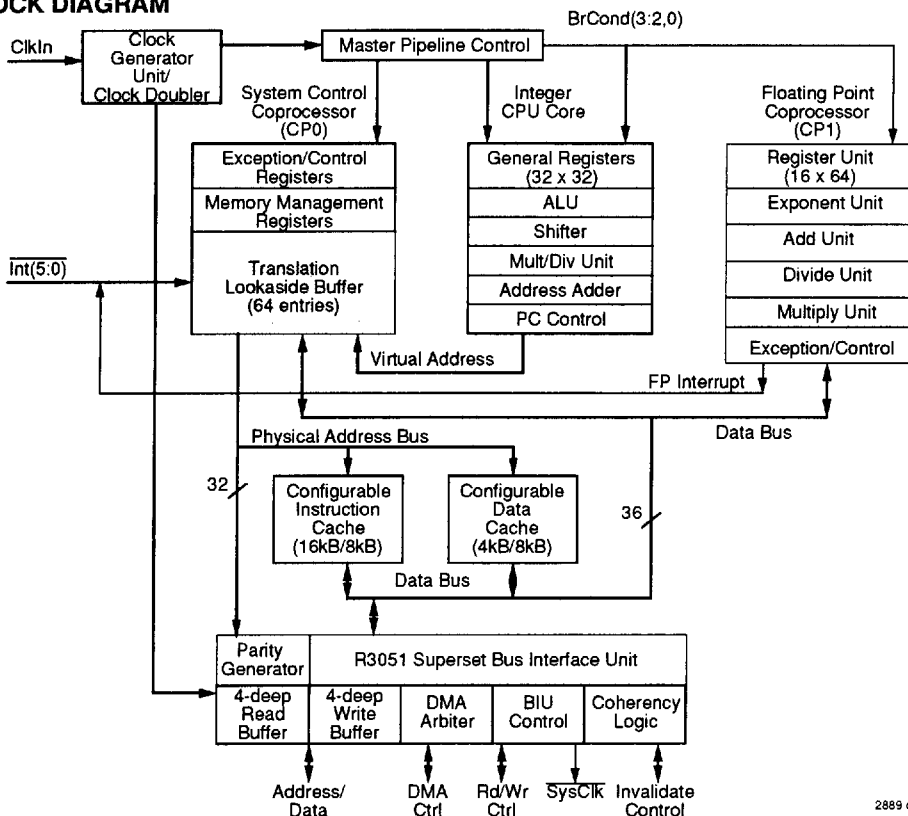

2899 orw 01

RISController, R3051, R3052, and R3081 are trademarks of Integrated Device Technology, Inc. All others are trademarks of their respective companies

**COMMERCIAL TEMPERATURE RANGE**

**OCTOBER 1992**

**INTRODUCTION**

The IDT R3051 family is a series of high-performance 32-bit microprocessors featuring a high-level of integration, and targeted to high-performance but cost sensitive processing applications. The R3051 family is designed to bring the high-performance inherent in the MIPS RISC architecture into low-cost, simplified, power sensitive applications.

Thus, functional units have been integrated onto the CPU core in order to reduce the total system cost, rather than to increase the inherent performance of the integer engine. Nevertheless, the R3051 family is able to offer 35 VUPS performance at 40MHz without requiring external SRAM or caches.

The R3081 extends the capabilities of the R3051 family, by integrating additional resources into the same pin-out. The R3081 thus extends the range of applications addressed by the R3051 family, and allows designers to implement a single, base system and software set capable of accepting a wide variety of CPUs, according to the price/performance goals of the end system.

In addition to the embedded applications served by the R3051 family, the R3081 allows low-cost, entry level computer systems to be constructed. These systems will offer many times the performance of traditional PC systems, yet cost approximately the same. The R3081 is able to run any standard R3000A operation system, including ACE UNIX. Thus, the R3081 can be used to build a low-cost ARC compliant system, further widening the range of performance solutions of the ACE Initiative.

An overview of this device, and quantitative electrical parameters and mechanical data, is found in this data sheet; consult the "R3081 Family Hardware User's Guide" for a complete description of this processor.

- The R3051, which incorporates 4kB of instruction cache and 2kB of data cache, but omits the TLB, and instead uses a simpler virtual to physical address mapping.
- The R3081E, which incorporates a 16kB instruction cache, a 4kB data cache, and full function memory management unit (MMU) including 64-entry fully associative Translation Lookaside Buffer (TLB). The cache on the R3081E is user configurable to an 8kB Instruction Cache and 8kB Data Cache.
- The R3081, which incorporates a 16kB instruction cache, a 4kB data cache, but uses the simpler memory mapping of the R3051/52, and thus omits the TLB. The cache on the R3081 is user configurable to an 8kB Instruction Cache and 8kB Data Cache.

Figure 1 shows a block level representation of the functional units within the R3081E. The R3081E could be viewed as the embodiment of a discrete solution built around the R3000A and R3010A. However, by integrating this functionality on a single chip, dramatic cost and power reductions are achieved.

**CPU Core**

The CPU core is a full 32-bit RISC integer execution engine, capable of sustaining close to single cycle execution. The CPU core contains a five stage pipeline, and 32 orthogonal 32-bit registers. The R3081 uses the same basic integer execution core as the entire R3051 family, which is the R3000A implementation of the MIPS instruction set. Thus, the R3081 family is binary compatible with the R3051, R3052, R3000A, R3001, and R3500 CPUs. In addition, the R4000 represents an upwardly software compatible migration path to still higher levels of performance.

The execution engine in the R3081 uses a five-stage pipeline to achieve near single-cycle instruction execution rates. A new instruction can be initiated in each clock cycle; the execution engine actually processes five instructions concurrently (in various pipeline stages). Figure 2 shows the concurrency achieved in the R3081 execution pipeline.

5

**DEVICE OVERVIEW**

As part of the R3051 family, the R3081 extends the offering of a wide range of functionality in a compatible interface. The R3051 family allows the system designer to implement a single base system, and utilize interface-compatible processors of various complexity to achieve the price-performance goals of the particular end system.

Differences among the various family members pertain to the on-chip resources of the processor. Current family members include:

- The R3052E, which incorporates an 8kB instruction cache, a 2kB data cache, and full function memory management unit (MMU) including 64-entry fully associative Translation Lookaside Buffer (TLB).
- The R3052, which also incorporates an 8kB instruction cache and 2kB data cache, but does not include the TLB, and instead uses a simpler virtual to physical address mapping.
- The R3051E, which incorporates 4kB of instruction cache and 2kB of data cache, along with the full function MMU/TLB of the R3000A.

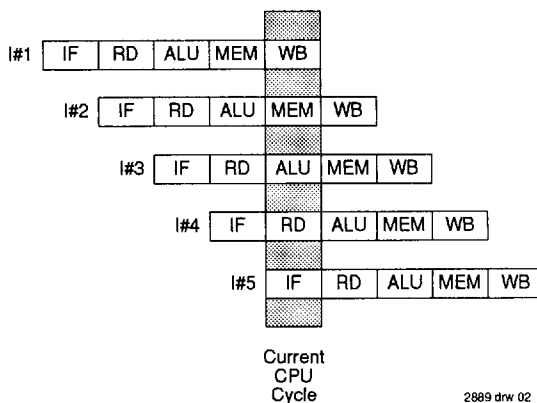

2889 drw 02

Figure 2. R3081 5-Stage Pipeline

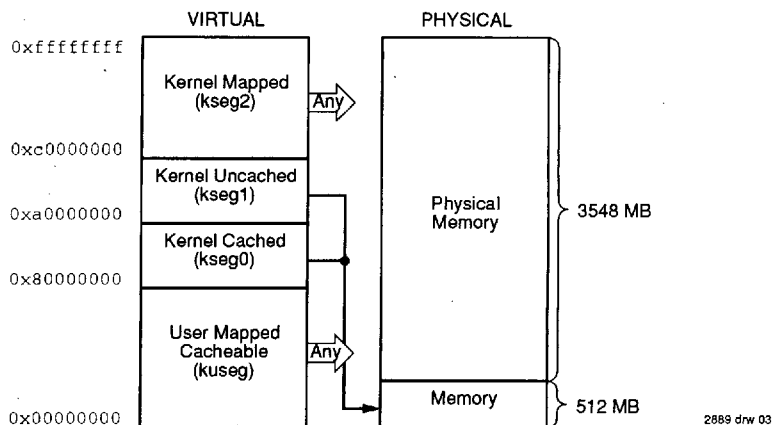

Figure 3. Virtual to Physical Mapping of Extended Architecture Versions

**System Control Co-Processor**

The R3081 family also integrates on-chip the System Control Co-processor, CP0. CP0 manages both the exception handling capability of the R3081, as well as the virtual to physical address mapping.

As with the R3051 and R3052, the R3081 offers two versions of memory management and virtual to physical address mapping: the extended architecture versions, the R3051E, R3052E, and R3081E, incorporate the same MMU as the R3000A. These versions contain a fully associative 64-entry TLB which maps 4kB virtual pages into the physical address space. The virtual to physical mapping thus includes kernel segments which are hard-mapped to physical addresses, and kernel and user segments which are mapped page by page by the TLB into anywhere in the 4GB physical address space. In this TLB, 8 pages can be "locked" by the kernel to insure deterministic response in real-time applications. Figure 3 illustrates the virtual to physical mapping found in the R3081E.

The Extended architecture versions of the R3051 family (the R3051E, R3052E, and R3081E) allow the system designer to implement kernel software which dynamically manages User task utilization of system resources, and also allows the Kernel to protect certain resources from User tasks. These capabilities are important in general computing applications such as ARC computers, and are also important in a variety of embedded applications, from process control (where protection may be important) to X-Window display systems (where virtual memory management can be used). The MMU can also be used to simplify system debug.

R3051 family base versions (the R3051, R3052, and R3081) remove the TLB and institute a fixed address mapping for the various segments of the virtual address space. These devices still support distinct kernel and user mode operation, but do not require page management software, leading to a simpler software model. The memory mapping used by these devices is shown in Figure 4. Note that the reserved spaces are for compatibility with future family members, which may

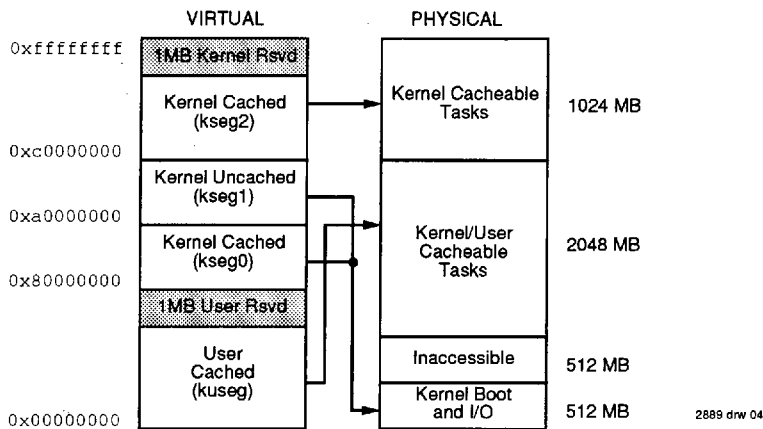

Figure 4. Virtual to Physical Mapping of Base Architecture Versions

map on-chip resources to these addresses. References to these addresses in the R3081 will be translated in the same fashion as the rest of their respective segments, with no traps or exceptions signalled.

When using the base versions of the architecture, the system designer can implement a distinction between the user tasks and the kernel tasks, without having to implement page management software. This distinction can be implemented by decoding the output physical address. In systems which do not need memory protection, and wish to have the kernel and user tasks operate out of the same memory space, high-order address lines can be ignored by the address decoder, and thus all references will be seen in the lower gigabyte of the physical address space.

**Floating Point Co-Processor**

The R3081 also integrates an R3010A compatible floating point accelerator on-chip. The FPA is a high performance co-processor (co-processor 1 to the CPU) providing separate add, multiply, and divide functional units for single and double precision floating point arithmetic. The floating point accelerator features low latency operations, and autonomous functional units which allow differing types of floating point operations to function concurrently with integer operations. The R3010A appears to the software programmer as a simple extension of the integer execution unit, with 16 dedicated 64-bit floating point registers (software references these as 32 32-bit registers when performing loads or stores). Figure 5 illustrates the functional block diagram of the on-chip FPA.

**Clock Generator Unit**

The R3081 is driven from a single input clock which can be either at the processor rated speed, or at twice that speed. On-chip, the clock generator unit is responsible for managing the interaction of the CPU core, caches, and bus interface. The R3081 includes an on-chip clock doubler to provide higher frequency signals to the internal execution core; if 1x clock mode is selected, the clock doubler will internally convert it to a double frequency clock. The 2x clock mode is provided for compatibility with the R3051. The clock generator unit replaces the external delay line required in R3000A based applications.

**Instruction Cache**

The R3081 implements a 16kB Instruction Cache. The system may choose to repartition the on-chip caches, so that the instruction cache is reduced to 8kB but the data cache is increased to 8kB. The instruction cache is organized with a line size of 16 bytes (four entries). This large cache achieves hit rates in excess of 98% in most applications, and substantially contributes to the performance inherent in the R3081. The cache is implemented as a direct mapped cache, and is capable of caching instructions from anywhere within the 4GB physical address space. The cache is implemented using physical addresses (rather than virtual addresses), and thus does not require flushing on context switch.

The instruction cache is parity protected over the instruction word and tag fields. Parity is generated by the read buffer during cache refill; during cache references, the parity is checked, and in the case of a parity error, a cache miss is processed.

5

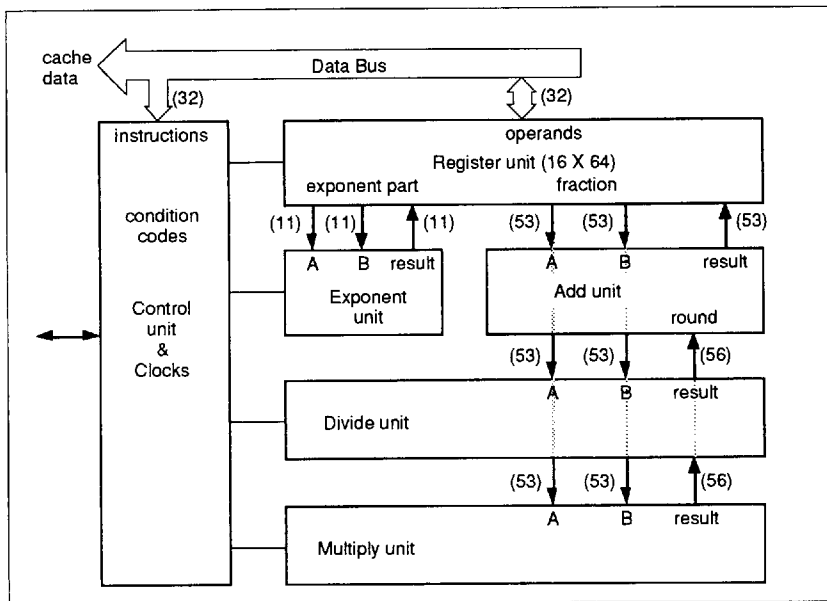

2889 drw 05

Figure 5. FPA Functional Block Diagram

### Data Cache

The R3081 incorporates an on-chip data cache of 4kB, organized as a line size of 4 bytes (one word). The R3081 allows the system to reconfigure the on-chip cache from the default 16kB I-Cache/4kB D-Cache to 8kB of Instruction and 8kB of Data caches.

The relatively large data cache achieves hit rates in excess of 95% in most applications, and contributes substantially to the performance inherent in the R3081. As with the instruction cache, the data cache is implemented as a direct mapped physical address cache. The cache is capable of mapping any word within the 4GB physical address space.

The data cache is implemented as a write-through cache, to insure that main memory is always consistent with the internal cache. In order to minimize processor stalls due to data write operations, the bus interface unit incorporates a 4-deep write buffer which captures address and data at the processor execution rate, allowing it to be retired to main memory at a much slower rate without impacting system performance. Further, support has been provided to allow hardware based data cache coherency in a multi-master environment, such as one utilizing DMA from I/O to memory.

The data cache is parity protected over the data and tag fields. Parity is generated by the read buffer during cache refill; during cache references, the parity is checked, and in the case of a parity error, a cache miss is processed.

### Bus Interface Unit

The R3081 uses its large internal caches to provide the majority of the bandwidth requirements of the execution engine, and thus can utilize a simple bus interface connected to slower memory devices. Alternately, a high-performance, low cost secondary cache can be implemented, allowing the processor to increase performance in systems where bus bandwidth is a performance limitation.

As part of the R3051 family, the R3081 bus interface utilizes a 32-bit address and data bus multiplexed onto a single set of pins. The bus interface unit also provides an ALE (Address

Latch Enable) output signal to de-multiplex the A/D bus, and simple handshake signals to process CPU read and write requests. In addition to the read and write interface, the R3051 family incorporates a DMA arbiter, to allow an external master to control the external bus.

The R3081 also supports hardware based cache coherency during DMA writes. The R3081 can invalidate a specified line of data cache, or in fact can perform burst invalidations during burst DMA writes.

The R3081 incorporates a 4-deep write buffer to decouple the speed of the execution engine from the speed of the memory system. The write buffers capture and FIFO processor address and data information in store operations, and present it to the bus interface as write transactions at the rate the memory system can accommodate.

The R3081 read interface performs both single datum reads and quad word reads. Single reads work with a simple handshake, and quad word reads can either utilize the simple handshake (in lower performance, simple systems) or utilize a tighter timing mode when the memory system can burst data at the processor clock rate. Thus, the system designer can choose to utilize page or nibble mode DRAMs (and possibly use interleaving, if desired, in high-performance systems), or use simpler techniques to reduce complexity.

In order to accommodate slower quad word reads, the R3081 incorporates a 4-deep read buffer FIFO, so that the external interface can queue up data within the processor before releasing it to perform a burst fill of the internal caches.

The R3081 is R3051 superset compatible in its bus interface. Specifically, the R3081 has additional support to simplify the design of very high frequency systems. This support includes the ability to run the bus interface at one-half the processor execution rate, as well as the ability to slow the transitions between reads and writes to provide extra buffer disable time for the memory interface. However, it is still possible to design a system which, with no modification to the PC Board or software, can accept either an R3051, R3052, or R3081.

**SYSTEM USAGE**

The IDT R3051 family has been specifically designed to allow a wide variety of memory systems. Low-cost systems can use slow speed memories and simple controllers, while other designers may choose to incorporate higher frequencies, faster memories, and techniques such as DMA to achieve maximum performance. The R3081 includes specific support for high performance systems, including signals necessary to implement external secondary caches, and the ability to perform hardware based cache coherency in multi-master systems.

Figure 6 shows a typical system implementation. Transparent latches are used to de-multiplex the R3081 address and data buses from the A/D bus. The data paths between the memory system elements and the A/D bus is managed by simple octal devices. A small set of simple PALs

is used to control the various data path elements, and to control the handshake between the memory devices and the CPU. IDT has implemented the R3720/21 support chip set specifically tailored to R3051 family systems. This chip set directly interfaces the processor to DRAM, simplifying design and eliminating discrete logic chips and PAL devices.

Depending on the cost vs. performance tradeoffs appropriate to a given application, the system design engineer could include true burst support from the DRAM to provide for high-performance cache miss processing, or utilize a simpler, lower performance memory system to reduce cost and simplify the design. Similarly, the system designer could choose to implement techniques such as external secondary cache, or DMA, to further improve system performance.

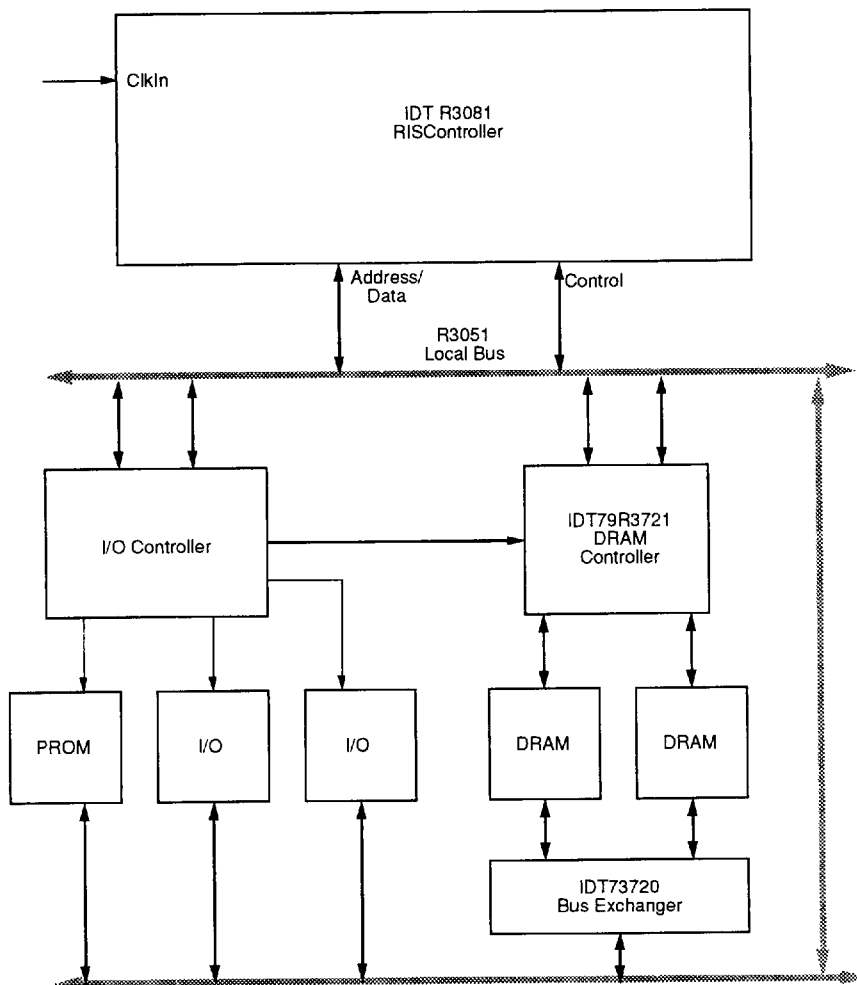

Figure 6. R3081 RISChipset Based System

2889 drw 06

5

**DEVELOPMENT SUPPORT**

The IDT R3051 family is supported by a rich set of development tools, ranging from system simulation tools through PROM monitor and debug support, applications software and utility libraries, logic analysis tools, sub-system modules, and shrink wrap operating systems. The R3081, which is pin and software compatible with the R3051, can directly utilize these existing tools to reduce time to market.

Figure 7 is an overview of the system development process typically used when developing R3051 family applications. The R3051 family is supported in all phases of project development. These tools allow timely, parallel development of hardware and software for R3051 family applications, and include tools such as:

- A program, Cache-R3051, which allows the performance of an R3051 family system to be modeled and understood without requiring actual hardware.
- Sable, an instruction set simulator.
- Optimizing compilers from MIPS, the acknowledged leader in optimizing compiler technology.

- Cross development tools, available in a variety of development environments.
- The high-performance IDT floating point library software, including transcendental functions and IEEE compliant exception handlers.
- The IDT Evaluation Board, which includes RAM, EPROM, I/O, and the IDT PROM Monitor.
- The IDT Laser Printer System board, which directly drives a low-cost print engine, and runs Microsoft TrueImage™ Page Description Language on top of PeerlessPage™ Advanced Printer Controller BIOS.
- Adobe PostScript™ Page Description Language, ported to the R3000 instruction set, runs on the IDT R3051 family.
- IDT/sim, which implements a full prom monitor (diagnostics, remote debug support, peek/poke, etc.).
- IDT/sae, which implements a run-time support package for R3051 family systems.
- ACE UNIX operating system; bringing ACE compatibility.

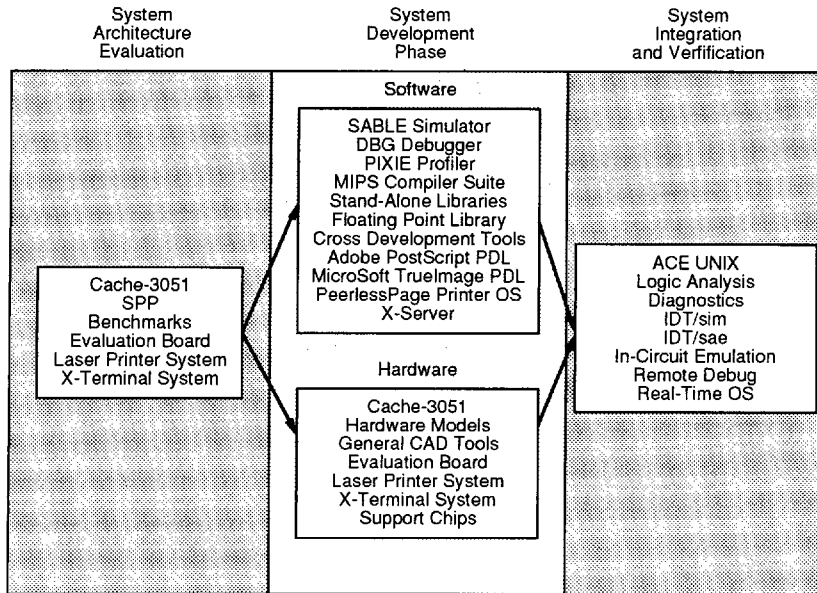

2889 drw 07

Figure 7. R3051 Family Development Toolchain

## PERFORMANCE OVERVIEW

The R3081 achieves a very high-level of performance. This performance is based on:

- An efficient execution engine. The CPU performs ALU operations and store operations in a single cycle, and has an effective load time of 1.3 cycles, and branch execution rate of 1.5 cycles (based on the ability of the compilers to avoid software interlocks). Thus, the execution engine achieves over 35 VUPS performance when operating out of cache.
  - A full featured floating point accelerator/co-processor. The R3081 incorporates an R3010A compatible floating point accelerator on-chip, with independent ALUs for floating point add, multiply, and divide. The floating point unit is fully hardware interlocked, and features overlapped operation and precise exceptions. The FPA allows floating point adds, multiplies, and divides to occur concurrently with each other, as well as concurrently with integer operations.
  - Large on-chip caches. The R3051 family contains caches which are substantially larger than those on the majority of today's microprocessors. These large caches minimize the number of bus transactions required, and allow the R3051 family to achieve actual sustained performance very close to its peak execution rate. The R3081 doubles the cache available on the R3052, making it a suitable engine for many general purpose computing applications, such as ARC compliant systems.
  - Autonomous multiply and divide operations. The R3051 family features an on-chip integer multiplier/divide unit which is separate from the other ALU. This allows the CPU to perform multiply or divide operations in parallel with other integer operations, using a single multiply or divide instruction rather than "step" operations.
  - Integrated write buffer. The R3081 features a four deep write buffer, which captures store target addresses and data at the processor execution rate and retires it to main memory at the slower main memory access rate. Use of on-chip write buffers eliminates the need for the processor to stall when performing store operations.
  - Burst read support. The R3051 family enables the system designer to utilize page mode or nibble mode RAMs when performing read operations to minimize the main memory read penalty and increase the effective cache hit rates.
- These techniques combine to allow the processor to achieve over 35 VUPS integer performance, 11MFlops of Linpack performance, and 64,000 dhrystones without the use of external caches or zero wait-state memory devices.

The performance differences between the various family members depends on the application software and the design

of the memory system. The impact of the various cache sizes, and the hardware floating point, can be accurately modeled using Cache-3051. Since the R3051, R3052, and R3081 are all pin and software compatible, the system designer has maximum freedom in trading between performance and cost. A system can be designed, and later the appropriate CPU inserted into the board, depending on the desired system performance.

## SELECTABLE FEATURES

The R3081 allows the system designer to configure certain aspects of operation. Some of these options are established when the device is reset, while others are enabled via the Config registers:

- BigEndian vs. LittleEndian Byte Ordering. The part can be configured to operate with either byte ordering. ACE/ARC systems typically use Little Endian byte ordering. However, various embedded applications, written originally for a Big Endian processor such as the MC680x0, are easier to port to a Big Endian system.
- Data Cache Refill of one or four words. The memory system must be capable of performing four word refills of instruction cache misses. The R3081 allows the system designer to enable D-Cache refill of one or four words dynamically. Thus, specialized algorithms can choose one refill size, while the rest of the system can operate with the other.
- Half-frequency bus mode. The processor can be configured such that the external bus interface is at one-half the frequency of the processor core. This simplifies system design; however, the large on-chip caches mitigate the performance impact of using a slower system bus clock.
- Slow bus turn-around. The R3081 allows the system designer to space processor operations, so that more time is allowed for transitions between memory and the processor on the multiplexed address/data bus.
- Configurable cache. The R3081 allows the system designer to use software to select either a 16kB Instruction Cache/4kB Data Cache organization, or an 8kB Instruction/8kB Data Cache organization.
- Cache Coherent Interface. The R3081 has an optional hardware based cache coherency interface intended to support multi-master systems such as those utilizing DMA between memory and I/O.
- Optional 1x or 2x clock input. The R3081 can be driven with an R3051 compatible 2x clock input, or a lower frequency 1x clock input.



## THERMAL CONSIDERATIONS

The R3081 utilizes special packaging techniques to improve the thermal properties of high-speed processors. Thus, the R3081 is packaged using cavity down packaging, with an embedded thermal slug to improve thermal transfer to the surrounding air.

The R3081 utilizes the 84-pin MQAD package (the "MJ" package), which is an all aluminum package with the die attached to a normal copper lead-frame mounted to the aluminum casing. The MQAD package allows for an efficient thermal transfer between the die and the case due to the heat spreading effect of the aluminum. The aluminum offers less internal resistance from one end of the package to the other, reducing the temperature gradient across the package and therefore presenting a greater area for convection and conduction to the PCB for a given temperature. Even nominal amounts of airflow will dramatically reduce the junction temperature of the die, resulting in cooler operation. The MQAD package is available at all frequencies, and is pin and form compatible with the PLCC used for the R3051. Thus, designers can inter-change R3081's and R3051's in a particular design, without changing their PC Board.

Finally, the R3081 is also available in a cavity-down PGA with exposed thermal slug. As with the MQAD package, this package is extremely thermal efficient, and is appropriate in extreme temperature conditions, such as military systems.

The R3081 is guaranteed in a case temperature range of 0°C to +85°C. The type of package, speed (power) of the device, and airflow conditions, affect the equivalent ambient temperature conditions which will meet this specification.

The equivalent allowable ambient temperature,  $T_A$ , can be calculated using the thermal resistance from case to ambient ( $\theta_{CA}$ ) of the given package. The following equation relates ambient and case temperatures:

$$T_A = T_C - P * \theta_{CA}$$

where P is the maximum power consumption at hot temperature, calculated by using the maximum Icc specification for the device.

Typical values for  $\theta_{CA}$  at various airflows are shown in Table 1.

Note that the R3081 allows the operational frequency to be turned down during idle periods to reduce power consumption. This operation is described in the *R3081 Hardware User's Guide*. Reducing the operation frequency dramatically reduces power consumption.

Airflow (ft/min)	$\theta_{CA}$					
	0	200	400	600	800	1000
"MJ" Package*	22	14	12	11	9	8
PGA Package	29	15	9	7	6	5

2889 tbl 01

Table 1. Thermal Resistance ( $\theta_{CA}$ ) at Various Airflows  
(\*estimated; final values tbd)

**PIN DESCRIPTION**

PIN NAME	I/O	DESCRIPTION
A/D(31:0)	I/O	<p><b>Address/Data:</b> A 32-bit time multiplexed bus which indicates the desired address for a bus transaction in one phase, and which is used to transmit data between the CPU and external memory resources during the rest of the transfer.</p> <p>Bus transactions on this bus are logically separated into two phases: during the first phase, information about the transfer is presented to the memory system to be captured using the ALE output. This information consists of:</p> <p><b>Address(31:4):</b> The high-order address for the transfer is presented on A/D(31:4).</p> <p><b><math>\overline{BE}</math>(3:0):</b> These strobes indicate which bytes of the 32-bit bus will be involved in the transfer, and are presented on A/D(3:0).</p> <p>During write cycles, the bus contains the data to be stored and is driven from the internal write buffer. On read cycles, the bus receives the data from the external resource, in either a single data transaction or in a burst of four words, and places it into the on-chip read buffer.</p> <p>During cache coherency operations, the R3081 monitors the A/D bus at the start of a DMA write to capture the write target address for potential data cache invalidates.</p>
Addr(3:2)	O	<p><b>Low Address (3:2)</b> A 2-bit bus which indicates which word is currently expected by the processor. Specifically, this two bit bus presents either the address bits for the single word to be transferred (writes or single datum reads) or functions as a two bit counter starting at '00' for burst read operations.</p> <p>During cache coherency operations, the R3081 monitors the Addr bus at the start of a DMA write to capture the write target address for potential data cache invalidates.</p>
Diag(1)	O	<p><b>Diagnostic Pin 1.</b> This output indicates whether the current bus read transaction is due to an on-chip cache miss, and also presents part of the miss address. The value output on this pin is time multiplexed:</p> <p><b>Cached:</b> During the phase in which the A/D bus presents address information, this pin is an active high output which indicates whether the current read is a result of a cache miss.</p> <p><b>Miss Address (3):</b> During the remainder of the read operation, this output presents address bit (3) of the address the processor was attempting to reference when the cache miss occurred. Regardless of whether a cache miss is being processed, this pin reports the transfer address during this time.</p> <p>On write cycles, this output signals whether the data being written is retained in the on-chip data cache. The value of this pin is time multiplexed during writes:</p> <p><b>Cached:</b> During the address phase of write transactions, this signal is an active high output which indicates that the store data was retained in the on-chip data cache.</p> <p><b>Reserved:</b> The value of this pin during the data phase of writes is reserved.</p>
Diag(0)	O	<p><b>Diagnostic Pin 0.</b> This output distinguishes cache misses due to instruction references from those due to data references, and presents the remaining bit of the miss address. The value output on this pin is also time multiplexed:</p> <p><b><math>\overline{ID}</math>:</b> If the "Cached" Pin indicates a cache miss, then a high on this pin at this time indicates an instruction reference, and a low indicates a data reference. If the read is not due to a cache miss but rather an uncached reference, then this pin is undefined during this phase.</p> <p><b>Miss Address (2):</b> During the remainder of the read operation, this output presents address bit (2) of the address the processor was attempting to reference when the cache miss occurred. Regardless of whether a cache miss is being processed, this pin reports the transfer address during this time.</p> <p>During write cycles, the value of this pin during both the address and data phases is reserved.</p>

5

**PIN DESCRIPTION (Continued):**

PIN NAME	I/O	DESCRIPTION
ALE	I/O	<b>Address Latch Enable:</b> Used to indicate that the A/D bus contains valid address information for the bus transaction. This signal is used by external logic to capture the address for the transfer, typically using transparent latches.  During cache coherency operations, the R3081 monitors ALE at the start of a DMA write, to capture the write target address for potential data cache invalidates.
$\overline{Rd}$	O	<b>Read:</b> An output which indicates that the current bus transaction is a read.
$\overline{Wr}$	I/O	<b>Write:</b> An output which indicates that the current bus transaction is a write.  During coherent DMA, this input indicates that the current transfer is a write.
$\overline{DataEn}$	O	<b>External Data Enable:</b> This signal indicates that the A/D bus is no longer being driven by the processor during read cycles, and thus the external memory system may enable the drivers of the memory system onto this bus without having a bus conflict occur. During write cycles, or when no bus transaction is occurring, this signal is negated, thus disabling the external memory drivers
$\overline{Burst}/\overline{WrNear}$	O	<b>Burst Transfer/Write Near:</b> On read transactions, the $\overline{Burst}$ signal indicates that the current bus read is requesting a block of four contiguous words from memory. This signal is asserted only in read cycles due to cache misses; it is asserted for all I-Cache miss read cycles, and for D-Cache miss read cycles if quad word refill is currently selected.  On write transactions, the $\overline{WrNear}$ output tells the external memory system that the bus interface unit is performing back-to-back write transactions to an address within the same 512 word page as the prior write transaction. This signal is useful in memory systems which employ page mode or static column DRAMs, and allows near writes to be retired quickly.
$\overline{Ack}$	I	<b>Acknowledge:</b> An input which indicates to the device that the memory system has sufficiently processed the bus transaction, and that the CPU may either terminate the write cycle or process the read data from this read transfer.  During Coherent DMA, this input indicates that the current write transfer is completed, and that the internal invalidation address counter should be incremented.
$\overline{RdCEn}$	I	<b>Read Buffer Clock Enable:</b> An input which indicates to the device that the memory system has placed valid data on the A/D bus, and that the processor may move the data into the on-chip Read Buffer.
SysClk	O	<b>System Reference Clock:</b> An output from the CPU which reflects the timing of the internal processor "Sys" clock. This clock is used to control state transitions in the read buffer, write buffer, memory controller, and bus interface unit. This clock will either be at the same frequency as the CPU execution rate clock, or at one-half that frequency, as selected during reset.
$\overline{BusReq}$	I	<b>DMA Arbiter Bus Request:</b> An input to the device which requests that the CPU tri-state its bus interface signals so that they may be driven by an external master.
$\overline{BusGnt}$	O	<b>DMA Arbiter Bus Grant:</b> An output from the CPU used to acknowledge that a $\overline{BusReq}$ has been detected, and that the bus is relinquished to the external master.
$\overline{IvdReq}$	I	<b>Invalidate Request.</b> An input provided by an external DMA controller to request that the CPU invalidate the Data Cache line corresponding to the current DMA write target address. This signal is the same pin as Diag(0)
$\overline{CohReq}$	I	<b>Coherent DMA Request.</b> An input used by the external DMA controller to indicate that the requested DMA operations could involve hardware cache coherency. This signal is the $\overline{Rsvd}(0)$ of the R3051.
SBrCond(3:2) BrCond(0)	I	<b>Branch Condition Port:</b> These external signals are internally connected to the CPU signals CpCond(3:0). These signals can be used by the branch on co-processor condition instructions as input ports. There are two types of Branch Condition inputs: the SBrCond inputs have special internal logic to synchronize the inputs, and thus may be driven by asynchronous agents. The direct Branch Condition inputs must be driven synchronously. Note that BrCond(1) is used by the internal FPA, and thus is not available on an external pin.
$\overline{BusError}$	I	<b>Bus Error:</b> Input to the bus interface unit to terminate a bus transaction due to an external bus error. This signal is only sampled during read and write operations. If the bus transaction is a read operation, then the CPU will take a bus error exception.

## PIN DESCRIPTION (Continued):

PIN NAME	I/O	DESCRIPTION
$\overline{\text{Int}}(5:3)$ $\overline{\text{Sint}}(2:0)$	I	<p><b>Processor Interrupt:</b> During normal operation, these signals are logically the same as the <math>\overline{\text{Int}}(5:0)</math> signals of the R3000. During processor reset, these signals perform mode initialization of the CPU, but in a different (simpler) fashion than the interrupt signals of the R3000.</p> <p>There are two types of interrupt inputs: the <math>\overline{\text{Sint}}</math> inputs are internally synchronized by the processor, and may be driven by an asynchronous external agent. The direct interrupt inputs are not internally synchronized, and thus must be externally synchronized to the CPU. The direct interrupt inputs have one cycle lower latency than the synchronized interrupts. Note that the interrupt used by the on-chip FPA will not be monitored externally.</p>
Clkin	I	<p><b>Master Clock Input:</b> This input clock can be provided at the execution frequency of the CPU (1x clock mode) or at twice that frequency (2x clock mode), as selected at reset..</p>
Reset	I	<p><b>Master Processor Reset:</b> This signal initializes the CPU. Mode selection is performed during the last cycle of <math>\overline{\text{Reset}}</math>.</p>
Rsvd(4:1)	I/O	<p><b>Reserved:</b> These four signal pins are reserved for testing and for future revisions of this device. Users must not connect these pins. Note that Rsvd(0) of the R3051 is now used for the CohReq input pin.</p>

2889 tbi 04

**ABSOLUTE MAXIMUM RATINGS<sup>(1, 3)</sup>**

Symbol	Rating	Commercial	Military	Unit
V <sub>TERM</sub>	Terminal Voltage with Respect to GND	-0.5 to +7.0	-0.5 to +7.0	V
T <sub>C</sub>	Operating Case Temperature	0 to +85	-55 to +125	°C
T <sub>BIAS</sub>	Temperature Under Bias	-55 to +125	-65 to +135	°C
T <sub>STG</sub>	Storage Temperature	-55 to +125	-65 to +155	°C
V <sub>IN</sub>	Input Voltage	-0.5 to +7.0	-0.5 to +7.0	V

2889 tbi 05

**NOTES:**

- Stresses greater than those listed under ABSOLUTE MAXIMUM RATINGS may cause permanent damage to the device. This is a stress rating only and functional operation of the device at these or any other conditions above those indicated in the operational sections of this specification is not implied. Exposure to absolute maximum rating conditions for extended periods may affect reliability.
- V<sub>IN</sub> minimum = -3.0V for pulse width less than 15ns. V<sub>IN</sub> should not exceed V<sub>CC</sub> +0.5V.
- Not more than one output should be shorted at a time. Duration of the short should not exceed 30 seconds.

**RECOMMENDED OPERATING TEMPERATURE AND SUPPLY VOLTAGE**

Grade	Temperature	GND	V <sub>CC</sub>
Military	-55°C to +125°C (Case)	0V	5.0 ±10%
Commercial	0°C to +85°C (Case)	0V	5.0 ±5%
Commercial	0°C to +85°C (Case)	0V	3.3 ±5%

2889 tbi 07

**OUTPUT LOADING FOR AC TESTING**

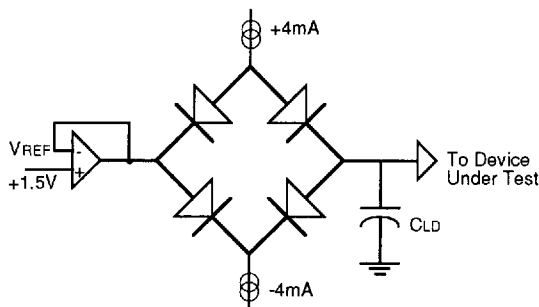

2889 drw 08

**AC TEST CONDITIONS—3081**

Symbol	Parameter	Min.	Max.	Unit
V <sub>IH</sub>	Input HIGH Voltage	3.0	—	V
V <sub>IL</sub>	Input LOW Voltage	—	0.4	V
V <sub>IHS</sub>	Input HIGH Voltage	3.5	—	V
V <sub>ILS</sub>	Input LOW Voltage	—	0.4	V

2889 tbi 06

**AC TEST CONDITIONS—3081L**

Symbol	Parameter	Min.	Max.	Unit
V <sub>IH</sub>	Input HIGH Voltage	3.0	—	V
V <sub>IL</sub>	Input LOW Voltage	—	0.4	V
V <sub>IHS</sub>	Input HIGH Voltage	3.5	—	V
V <sub>ILS</sub>	Input LOW Voltage	—	0.4	V

2889 tbi 06

Signal	C <sub>LD</sub>
SysClk	50 pf
All Others	25 pf

2889 tbi 08

**DC ELECTRICAL CHARACTERISTICS 3081—** (Tc = 0°C to +85°C, Vcc = +5.0V ±5%)

Symbol	Parameter	Test Conditions	20MHz		25MHz		33.33MHz		40MHz		Unit
			Min.	Max.	Min.	Max.	Min.	Max.	Min.	Max.	
VOH	Output HIGH Voltage	Vcc = Min., IOH = -4mA	3.5	—	3.5	—	3.5	—	3.5	—	V
VOL	Output LOW Voltage	Vcc = Min., IOL = 4mA	—	0.4	—	0.4	—	0.4	—	0.4	V
VIH	Input HIGH Voltage <sup>(3)</sup>	—	2.0	—	2.0	—	2.0	—	2.0	—	V
VIL	Input LOW Voltage <sup>(1)</sup>	—	—	0.8	—	0.8	—	0.8	—	0.8	V
VIHS	Input HIGH Voltage <sup>(2,3)</sup>	—	3.0	—	3.0	—	3.0	—	3.0	—	V
VILS	Input LOW Voltage <sup>(1,2)</sup>	—	—	0.4	—	0.4	—	0.4	—	0.4	V
CIN	Input Capacitance <sup>(4)</sup>	—	—	10	—	10	—	10	—	10	pF
COUT	Output Capacitance <sup>(4)</sup>	—	—	10	—	10	—	10	—	10	pF
ICC	Operating Current	Vcc = 5V, TA = 25°C	—	850	—	950	—	1050	—	1200	mA
IiH	Input HIGH Leakage	VIH = VCC	—	100	—	100	—	100	—	100	µA
IiL	Input LOW Leakage	VIL = GND	-100	—	-100	—	-100	—	-100	—	µA
IOZ	Output Tri-state Leakage	VOH = 2.4V, VOL = 0.5V	-100	100	-100	100	-100	100	-100	100	µA

2889 tbi 09

**NOTES:**

1. VIL Min. = -3.0V for pulse width less than 15ns. VIL should not fall below -0.5V for larger periods.
2. VIHS and VILS apply to ClkIn and Reset.
3. VIH should not be held above Vcc + 0.5V.
4. Guaranteed by design.

**DC ELECTRICAL CHARACTERISTICS 3081L—** (Tc = 0°C to +85°C, Vcc = +3.3V ±0.3V)

Symbol	Parameter	Test Conditions	20MHz		25MHz		33.33MHz		40MHz		Unit
			Min.	Max.	Min.	Max.	Min.	Max.	Min.	Max.	
VOH	Output HIGH Voltage	Vcc = Min., IOH = -4mA	2.4	—	2.4	—	2.4	—	2.4	—	V
VOL	Output LOW Voltage	Vcc = Min., IOL = 4mA	—	0.4	—	0.4	—	0.4	—	0.4	V
VIH	Input HIGH Voltage <sup>(3)</sup>	—	2.0	—	2.0	—	2.0	—	2.0	—	V
VIL	Input LOW Voltage <sup>(1)</sup>	—	—	0.8	—	0.8	—	0.8	—	0.8	V
VIHS	Input HIGH Voltage <sup>(2,3)</sup>	—	2.8	—	2.8	—	2.8	—	2.8	—	V
VILS	Input LOW Voltage <sup>(1,2)</sup>	—	—	0.4	—	0.4	—	0.4	—	0.4	V
CIN	Input Capacitance <sup>(4)</sup>	—	—	10	—	10	—	10	—	10	pF
COUT	Output Capacitance <sup>(4)</sup>	—	—	10	—	10	—	10	—	10	pF
ICC	Operating Current	Vcc = 3.3V, TA = 25°C	—	500	—	550	—	650	—	750	mA
IiH	Input HIGH Leakage	VIH = VCC	—	100	—	100	—	100	—	100	µA
IiL	Input LOW Leakage	VIL = GND	-100	—	-100	—	-100	—	-100	—	µA
IOZ	Output Tri-state Leakage	VOH = 2.4V, VOL = 0.5V	-100	100	-100	100	-100	100	-100	100	µA

2889 tbi 09

**NOTES:**

1. VIL Min. = -3.0V for pulse width less than 15ns. VIL should not fall below -0.5V for larger periods.
2. VIHS and VILS apply to ClkIn and Reset.
3. VIH should not be held above Vcc + 0.5V.
4. Guaranteed by design.

5

**AC ELECTRICAL CHARACTERISTICS 3081 (1, 2)** — (Tc = 0°C to +85°C, Vcc = +5.0V ±5%)

Symbol	Signals	Description	20MHz		25MHz		33.33MHz		40MHz		Unit
			Min.	Max.	Min.	Max.	Min.	Max.	Min.	Max.	
t1	BusReq, Ack, BusError, RdCEn, CohReq	Set-up to SysClk rising	6	—	5	—	4	—	3	—	ns
t1a	A/D	Set-up to SysClk falling	7	—	6	—	5	—	4.5	—	ns
t2	BusReq, Ack, BusError, RdCEn, CohReq	Hold from SysClk rising	4	—	4	—	3	—	3	—	ns
t2a	A/D	Hold from SysClk falling	2	—	2	—	1	—	1	—	ns
t3	A/D, Addr, Diag, ALE, Wr BurstWrNear, Rd, DataEn	Tri-state from SysClk rising	—	10	—	10	—	10	—	10	ns
t4	A/D, Addr, Diag, ALE, Wr BurstWrNear, Rd, DataEn	Driven from SysClk falling	—	10	—	10	—	10	—	10	ns
t5	BusGnt	Asserted from SysClk rising	—	8	—	7	—	6	—	5	ns
t6	BusGnt	Negated from SysClk falling	—	8	—	7	—	6	—	5	ns
t7	Wr, Rd, BurstWrNear, A/D	Valid from SysClk rising	—	5	—	5	—	4	—	3.5	ns
t8	ALE	Asserted from SysClk rising	—	4	—	4	—	3	—	3	ns
t9	ALE	Negated from SysClk falling	—	4	—	4	—	3	—	3	ns
t10	A/D	Hold from ALE negated	2	—	2	—	1.5	—	1.5	—	ns
t11	DataEn	Asserted from SysClk falling	—	15	—	15	—	13	—	12	ns
t12	DataEn	Asserted from A/D tri-state <sup>(3)</sup>	0	—	0	—	0	—	0	—	ns
t14	A/D	Driven from SysClk rising <sup>(3)</sup>	0	—	0	—	0	—	0	—	ns
t15	Wr, Rd, DataEn, BurstWrNear	Negated from SysClk falling	—	7	—	6	—	5	—	4	ns
t16	Addr(3:2)	Valid from SysClk	—	6	—	6	—	5	—	4.5	ns
t17	Diag	Valid from SysClk	—	12	—	11	—	10	—	9	ns
t18	A/D	Tri-state from SysClk falling	—	10	—	10	—	9	—	8	ns
t19	A/D	SysClk falling to data out	—	12	—	11	—	10	—	9	ns
t20	ClkIn (2x clock mode)	Pulse Width High	10	—	8	—	6.5	—	5.6	—	ns
t21	ClkIn (2x clock mode)	Pulse Width Low	10	—	8	—	6.5	—	5.6	—	ns
t22	ClkIn (2x clock mode)	Clock Period	25	250	20	250	15	250	12.5	250	ns
t23	Reset	Pulse Width from Vcc valid	200	—	200	—	200	—	200	—	µs
t24	Reset	Minimum Pulse Width	32	—	32	—	32	—	32	—	tsys
t25	Reset	Set-up to SysClk falling	6	—	5	—	4	—	3	—	ns
t26	int	Mode set-up to Reset rising	10	—	9	—	8	—	7	—	ns
t27	int	Mode hold from Reset rising	0	—	0	—	0	—	0	—	ns
t28	Sint, SBrCond	Set-up to SysClk falling	6	—	5	—	4	—	3	—	ns
t29	Sint, SBrCond	Hold from SysClk falling	3	—	3	—	2	—	2	—	ns
t30	int, BrCond	Set-up to SysClk falling	6	—	5	—	4	—	3	—	ns
t31	int, BrCond	Hold from SysClk falling	3	—	3	—	2	—	2	—	ns
tsys	SysClk (full frequency mode)	Pulse Width <sup>(5)</sup>	2*t22	2*t22	2*t22	2*t22	2*t22	2*t22	2*t22	2*t22	
t32	SysClk (full frequency mode)	Clock High Time <sup>(5)</sup>	t22-2	t22+2	t22-2	t22+2	t22-1	t22+1	t22-1	t22+1	ns

2889 tbl 10

**NOTES:**

1. All timings referenced to 1.5V.
2. The AC values listed here reference timing diagrams contained in the *R3081 Family Hardware User's Manual*.
3. Guaranteed by design.
4. This parameter is used to derate the AC timings according to the loading of the system. This parameter provides a deration for loads over the specified test condition; that is, the deration factor is applied for each 25pF over the specified test load condition.
5. In 1x clock mode, t22 is replaced by t44/2.

**AC ELECTRICAL CHARACTERISTICS 3081 (continued)<sup>(1, 2)</sup>** — (T<sub>C</sub> = 0°C to +85°C, V<sub>CC</sub> = +5.0V ±5%)

Symbol	Signals	Description	20MHz		25MHz		33.33MHz		40MHz		Unit
			Min.	Max.	Min.	Max.	Min.	Max.	Min.	Max.	
t33	SysClk (full frequency mode)	Clock Low Time <sup>(5)</sup>	t22-2	t22+2	t22-2	t22+2	t22-1	t22+1	t22-1	t22+1	ns
tsys/2	SysClk (half frequency mode)	Pulse Width <sup>(5)</sup>	4*t22	4*t22	4*t22	4*t22	4*t22	4*t22	4*t22	4*t22	
t34	SysClk (half frequency mode)	Clock High Time <sup>(5)</sup>	2*t22-2	2*t22+2	2*t22-2	2*t22+2	2*t22-1	2*t22+1	2*t22-1	2*t22+1	ns
t35	SysClk (half frequency mode)	Clock Low Time <sup>(5)</sup>	2*t22-2	2*t22+2	2*t22-2	2*t22+2	2*t22-1	2*t22+1	2*t22-1	2*t22+1	ns
t36	ALE	Set-up to SysClk falling	9	—	8	—	7	—	6	—	ns
t37	ALE	Hold from SysClk falling	2	—	2	—	1	—	1	—	ns
t38	A/D	Set-up to ALE falling	10	—	9	—	8	—	8	—	ns
t39	A/D	Hold from ALE falling	2	—	2	—	1	—	1	—	ns
t40	Wr	Set-up to SysClk rising	10	—	9	—	8	—	7	—	ns
t41	Wr	Hold from SysClk rising	3	—	3	—	3	—	3	—	ns
t42	ClkIn (1x clock mode)	Pulse Width High	20	—	16	—	13	—	11	—	ns
t43	ClkIn (1x clock mode)	Pulse Width Low	20	—	16	—	13	—	11	—	ns
t44	ClkIn (1x clock mode)	Clock Period	50	50	40	50	30	50	25	50	ns
tderate	All outputs	Timing deration for loading over C <sub>L</sub> <sup>(3, 4)</sup>	—	0.5	—	0.5	—	0.5	—	0.5	ns/ 25pF

2889 tbi 11

- NOTES:**
1. All timings referenced to 1.5V.
  2. The AC values listed here reference timing diagrams contained in the *R3081 Family Hardware User's Manual*.
  3. Guaranteed by design.
  4. This parameter is used to derate the AC timings according to the loading of the system. This parameter provides a deration for loads over the specified test condition; that is, the deration factor is applied for each 25pF over the specified test load condition.
  5. In 1x clock mode, t22 is replaced by t44/2.

5



**AC ELECTRICAL CHARACTERISTICS 3081L<sup>(1, 2)</sup>** — (T<sub>c</sub> = 0°C to +85°C, V<sub>cc</sub> = +3.3V ±5%)

Symbol	Signals	Description	20MHz		25MHz		33.33MHz		40MHz		Unit
			Min.	Max.	Min.	Max.	Min.	Max.	Min.	Max.	
t1	BusReq, Ack, BusError, RdCEn, CohReq	Set-up to SysClk rising	6	—	5	—	4	—	3	—	ns
t1a	A/D	Set-up to SysClk falling	7	—	6	—	5	—	4.5	—	ns
t2	BusReq, Ack, BusError, RdCEn, CohReq	Hold from SysClk rising	4	—	4	—	3	—	3	—	ns
t2a	A/D	Hold from SysClk falling	2	—	2	—	1	—	1	—	ns
t3	A/D, Addr, Diag, ALE, Wr Burst/WrNear, Rd, DataEn	Tri-state from SysClk rising	—	10	—	10	—	10	—	10	ns
t4	A/D, Addr, Diag, ALE, Wr Burst/WrNear, Rd, DataEn	Driven from SysClk falling	—	10	—	10	—	10	—	10	ns
t5	BusGnt	Asserted from SysClk rising	—	8	—	7	—	6	—	5	ns
t6	BusGnt	Negated from SysClk falling	—	8	—	7	—	6	—	5	ns
t7	Wr, Rd, Burst/WrNear, A/D	Valid from SysClk rising	—	5	—	5	—	4	—	3.5	ns
t8	ALE	Asserted from SysClk rising	—	4	—	4	—	3	—	3	ns
t9	ALE	Negated from SysClk falling	—	4	—	4	—	3	—	3	ns
t10	A/D	Hold from ALE negated	2	—	2	—	1.5	—	1.5	—	ns
t11	DataEn	Asserted from SysClk falling	—	15	—	15	—	13	—	12	ns
t12	DataEn	Asserted from A/D tri-state <sup>(3)</sup>	0	—	0	—	0	—	0	—	ns
t14	A/D	Driven from SysClk rising <sup>(3)</sup>	0	—	0	—	0	—	0	—	ns
t15	Wr, Rd, DataEn, Burst/WrNear	Negated from SysClk falling	—	7	—	6	—	5	—	4	ns
t16	Addr(3:2)	Valid from SysClk	—	6	—	6	—	5	—	4.5	ns
t17	Diag	Valid from SysClk	—	12	—	11	—	10	—	9	ns
t18	A/D	Tri-state from SysClk falling	—	10	—	10	—	9	—	8	ns
t19	A/D	SysClk falling to data out	—	12	—	11	—	10	—	9	ns
t20	ClkIn (2x clock mode)	Pulse Width High	10	—	8	—	6.5	—	5.5	—	ns
t21	ClkIn (2x clock mode)	Pulse Width Low	10	—	8	—	6.5	—	5.5	—	ns
t22	ClkIn (2x clock mode)	Clock Period	25	250	20	250	15	250	12.5	250	ns
t23	Reset	Pulse Width from Vcc valid	200	—	200	—	200	—	200	—	μs
t24	Reset	Minimum Pulse Width	32	—	32	—	32	—	32	—	tsys
t25	Reset	Set-up to SysClk falling	6	—	5	—	4	—	3	—	ns
t26	Int	Mode set-up to Reset rising	10	—	9	—	8	—	7	—	ns
t27	Int	Mode hold from Reset rising	0	—	0	—	0	—	0	—	ns
t28	SInt, SBrCond	Set-up to SysClk falling	6	—	5	—	4	—	3	—	ns
t29	SInt, SBrCond	Hold from SysClk falling	3	—	3	—	2	—	2	—	ns
t30	Int, BrCond	Set-up to SysClk falling	6	—	5	—	4	—	3	—	ns
t31	Int, BrCond	Hold from SysClk falling	3	—	3	—	2	—	2	—	ns
tsys	SysClk (full frequency mode)	Pulse Width <sup>(5)</sup>	2*t22	2*t22	2*t22	2*t22	2*t22	2*t22	2*t22	2*t22	
t32	SysClk (full frequency mode)	Clock High Time <sup>(5)</sup>	t22-2	t22+2	t22-2	t22+2	t22-1	t22+1	t22-1	t22+1	ns

2889 tbl 10

**NOTES:**

1. All timings referenced to 1.5V.
2. The AC values listed here reference timing diagrams contained in the *R3081 Family Hardware User's Manual*.
3. Guaranteed by design.
4. This parameter is used to derate the AC timings according to the loading of the system. This parameter provides a deration for loads over the specified test condition; that is, the deration factor is applied for each 25pF over the specified test load condition.
5. In 1x clock mode, t22 is replaced by t44/2.

AC ELECTRICAL CHARACTERISTICS 3081L (continued)<sup>(1, 2)</sup> (T<sub>c</sub> = 0°C to +85°C, V<sub>CC</sub> = +3.3V ±5%)

Symbol	Signals	Description	20MHz		25MHz		33.33MHz		40MHz		Unit
			Min.	Max.	Min.	Max.	Min.	Max.	Min.	Max.	
t33	$\overline{\text{SysClk}}$ (full frequency mode)	Clock Low Time <sup>(5)</sup>	t22-2	t22+2	t22-2	t22+2	t22-1	t22+1	t22-1	t22+1	ns
tsys/2	$\overline{\text{SysClk}}$ (half frequency mode)	Pulse Width <sup>(5)</sup>	4*t22	4*t22	4*t22	4*t22	4*t22	4*t22	4*t22	4*t22	ns
t34	$\overline{\text{SysClk}}$ (half frequency mode)	Clock High Time <sup>(5)</sup>	2*t22-2	2*t22+2	2*t22-2	2*t22+2	2*t22-1	2*t22+1	2*t22-1	2*t22+1	ns
t35	$\overline{\text{SysClk}}$ (half frequency mode)	Clock Low Time <sup>(5)</sup>	2*t22-2	2*t22+2	2*t22-2	2*t22+2	2*t22-1	2*t22+1	2*t22-1	2*t22+1	ns
t36	ALE	Set-up to $\overline{\text{SysClk}}$ falling	9	—	8	—	7	—	6	—	ns
t37	ALE	Hold from $\overline{\text{SysClk}}$ falling	2	—	2	—	1	—	1	—	ns
t38	A/D	Set-up to ALE falling	10	—	9	—	8	—	8	—	ns
t39	A/D	Hold from ALE falling	2	—	2	—	1	—	1	—	ns
t40	$\overline{\text{Wr}}$	Set-up to $\overline{\text{SysClk}}$ rising	10	—	9	—	8	—	7	—	ns
t41	$\overline{\text{Wr}}$	Hold from $\overline{\text{SysClk}}$ rising	3	—	3	—	3	—	3	—	ns
t42	Clkin (1x clock mode)	Pulse Width High	20	—	16	—	13	—	11	—	ns
t43	Clkin (1x clock mode)	Pulse Width Low	20	—	16	—	13	—	11	—	ns
t44	Clkin (1x clock mode)	Clock Period	50	50	40	50	30	50	25	50	ns
tderate	All outputs	Timing deration for loading over C <sub>LD</sub> <sup>(3, 4)</sup>	—	0.5	—	0.5	—	0.5	—	0.5	ns/ 25pF

2859 tbl 11

## NOTES:

- All timings referenced to 1.5V.
- The AC values listed here reference timing diagrams contained in the *R3081 Family Hardware User's Manual*.
- Guaranteed by design.
- This parameter is used to derate the AC timings according to the loading of the system. This parameter provides a deration for loads over the specified test condition; that is, the deration factor is applied for each 25pF over the specified test load condition.
- In 1x clock mode, t22 is replaced by t44/2.

**PIN CONFIGURATIONS**

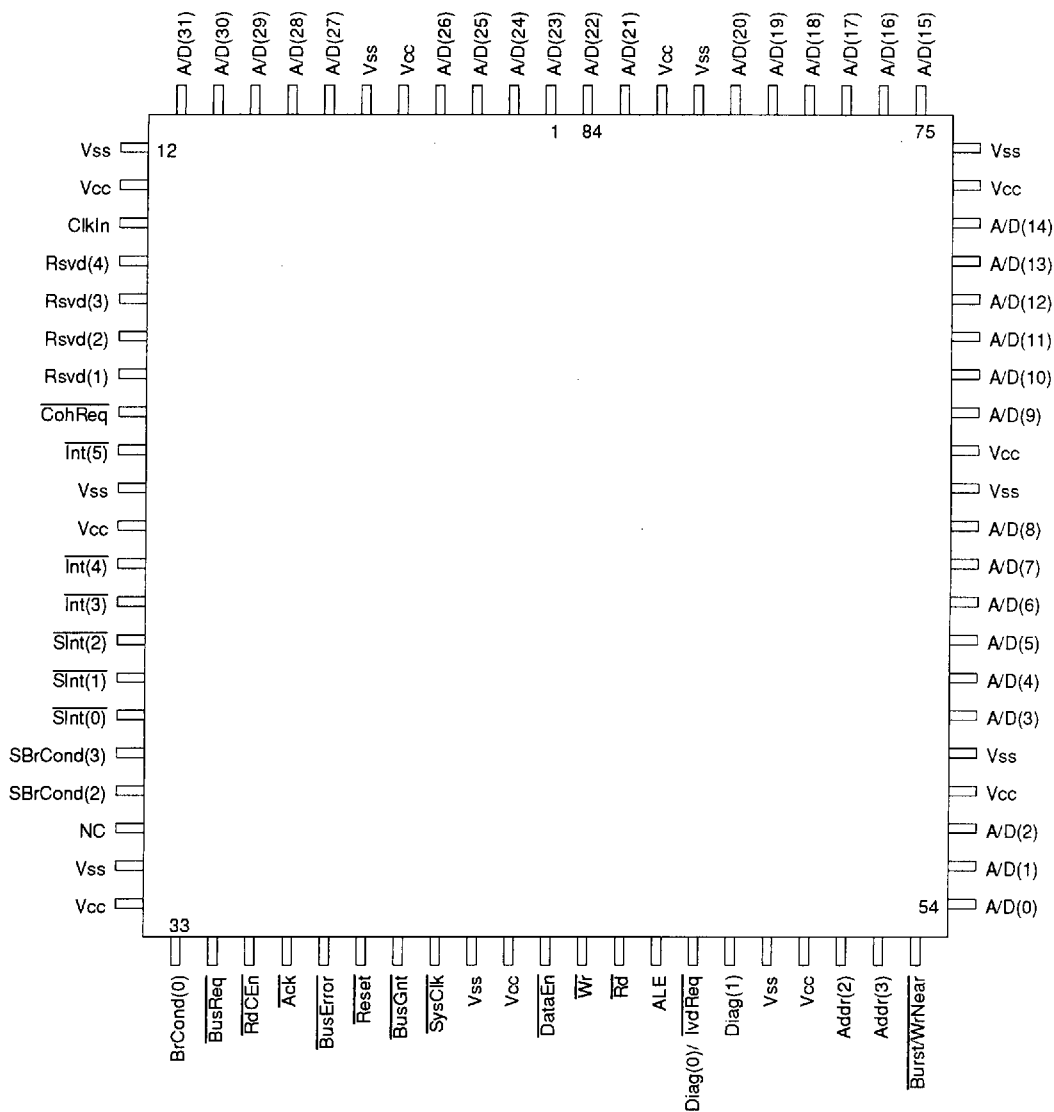

**84-Pin MQAD**  
**Top View**

**NOTE:**  
Reserved Pins must not be connected.

**PIN CONFIGURATIONS (CONTINUED)**

M	Vss	ClkIn	Rsvd (4)	Rsvd (2)	$\overline{\text{CohReq}}$	Vss	$\overline{\text{Int}}$ (4)	$\overline{\text{Int}}$ (3)	$\overline{\text{Slnt}}$ (1)	S BrCond (3)	S BrCond (2)	BrCond (0)							
L	A/D (28)	A/D (30)	Vcc	Rsvd (3)	Rsvd (1)	$\overline{\text{Int}}$ (5)	Vcc	$\overline{\text{Slnt}}$ (2)	$\overline{\text{Slnt}}$ (0)	NC	Vss	$\overline{\text{RdCEn}}$							
K	A/D (27)	A/D (29)	A/D (31)	<b>R3081</b> <b>84-Pin Ceramic Pin Grid Array</b> <b>(Cavity Down)</b> <b>Bottom View</b>							Vcc	$\overline{\text{BusReq}}$	$\overline{\text{Ack}}$						
J	Vcc	Vss									$\overline{\text{Bus}}$ Error	$\overline{\text{Reset}}$							
H	A/D (25)	A/D (26)									$\overline{\text{BusGnt}}$	SysClk							
G	A/D (23)	A/D (24)									Vcc	Vss							
F	A/D (21)	A/D (22)									$\overline{\text{Wr}}$	$\overline{\text{DataEn}}$							
E	Vcc	Vss									ALE	$\overline{\text{Rd}}$							
D	A/D (20)	A/D (19)									Diag (1)	Diag (0)/ IvdReq							
C	A/D (18)	A/D (16)	Vss								$\overline{\text{Burst/}}$ WrNear	Addr (2)	Vss						
B	A/D (17)	Vcc	A/D (14)								A/D (11)	A/D (9)	A/D (8)	A/D (6)	A/D (4)	Vss	A/D (1)	Addr (3)	Vcc
A	A/D (15)	A/D (13)	A/D (12)								A/D (10)	Vcc	Vss	A/D (7)	A/D (5)	A/D (3)	Vcc	A/D (2)	A/D (0)
	1	2	3	4	5	6	7	8	9	10	11	12							

**84-Pin PGA with Integral Thermal Slug**  
**BottomView**

2889 drw 10

**NOTE**  
Reserved Pins must not be connected.

**5**

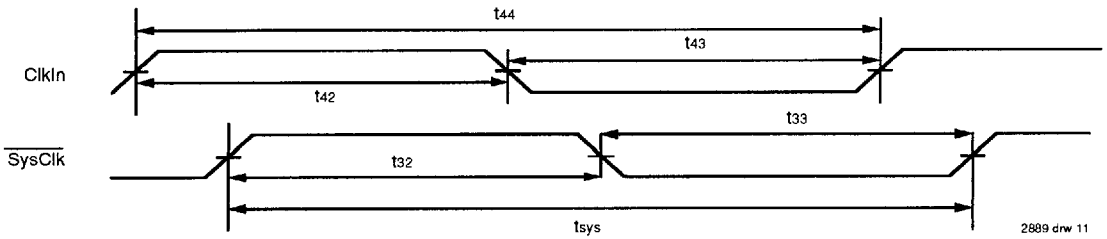

Figure 8 (a). R3081 Clocking (1x clock input mode, full frequency bus)

2889 drw 11

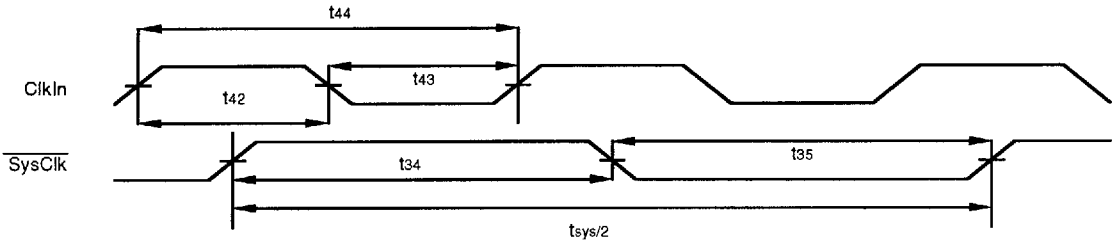

Figure 8 (b). R3081 Clocking (1x clock input mode, half-frequency bus)

2889 drw 12

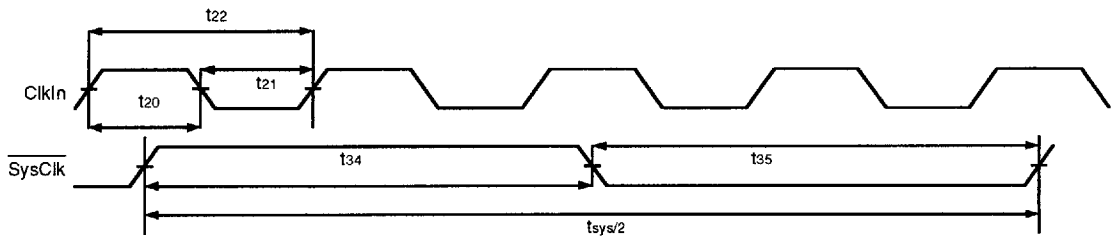

Figure 8 (c). R3081 Clocking (2x clock input mode, half-frequency bus)

2889 drw 13

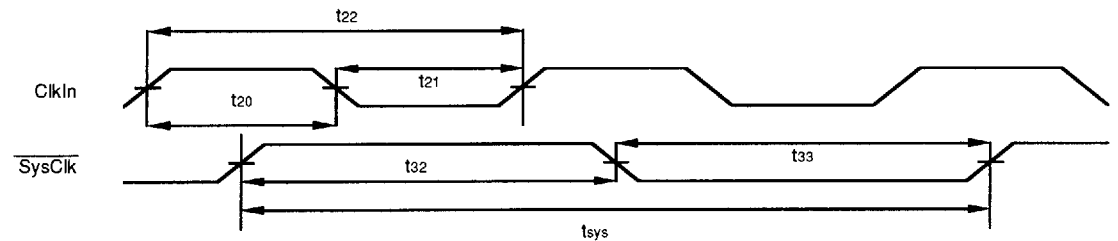

Figure 8 (d). R3081 Clocking (2x clock input mode, full-frequency bus)

2889 drw 14

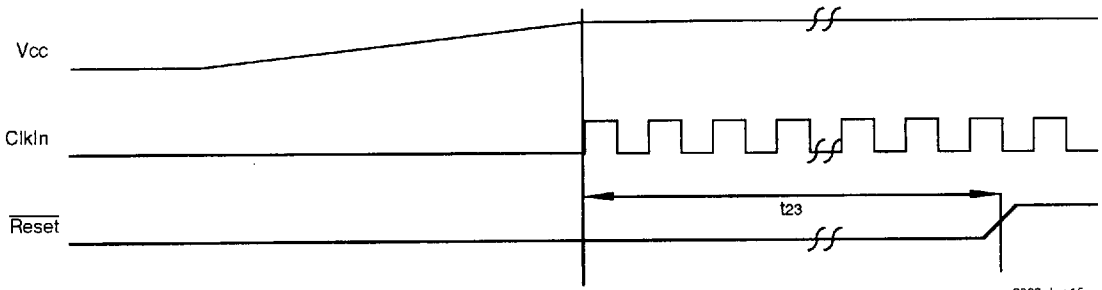

Figure 9. Power-On Reset Sequence

2889 drw 15

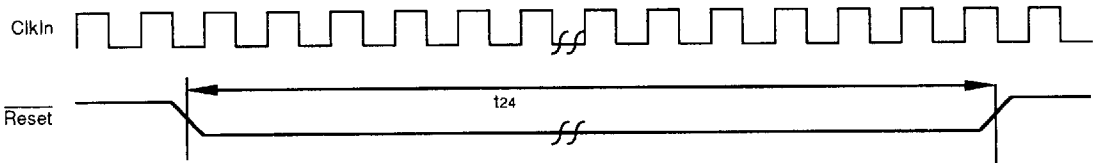

Figure 10. Warm Reset Sequence

2889 drw 16

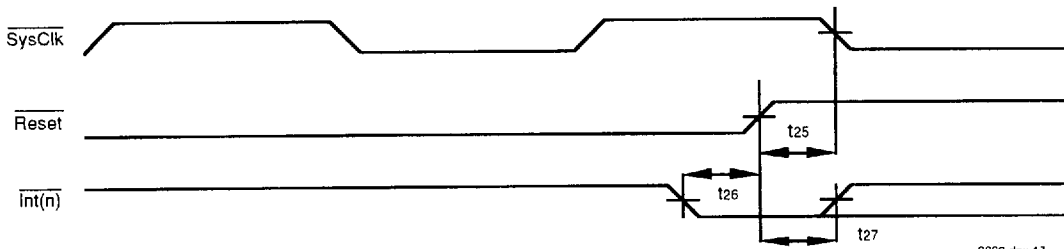
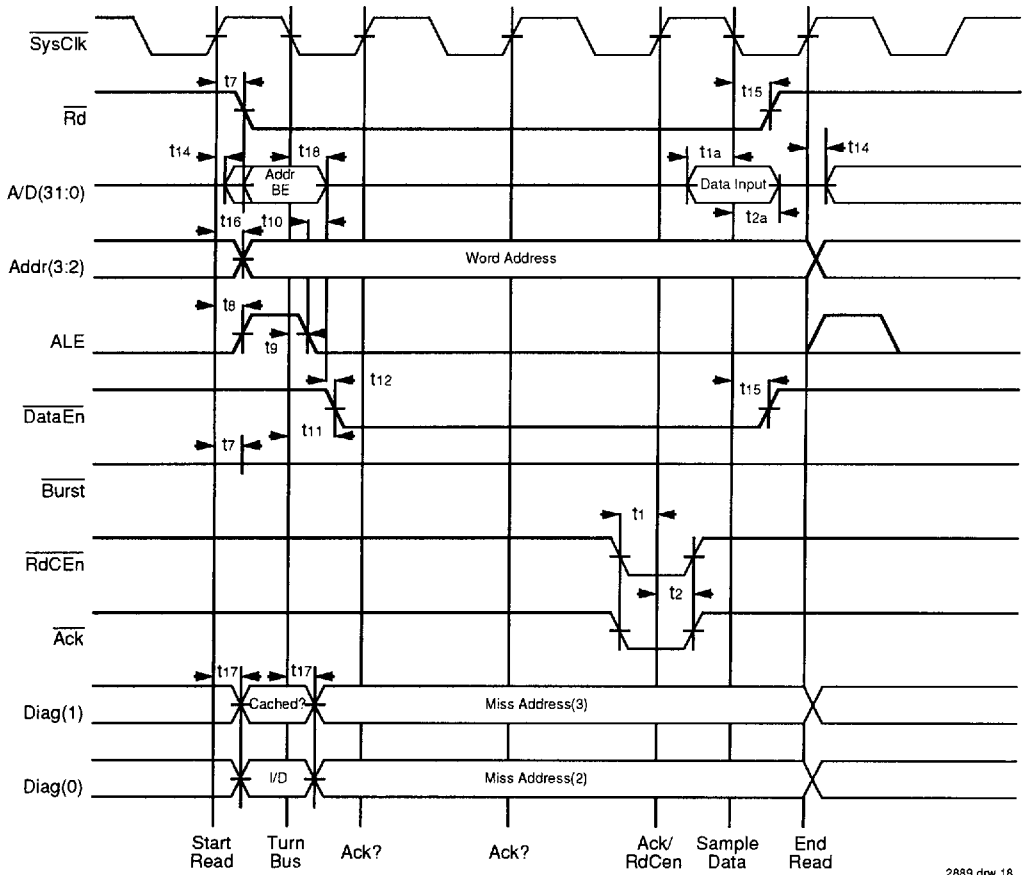

Figure 11. Mode Selection and Negation of Reset

2889 drw 17

5



2889 drw 18

Figure 12. Single Datum Read in R3081

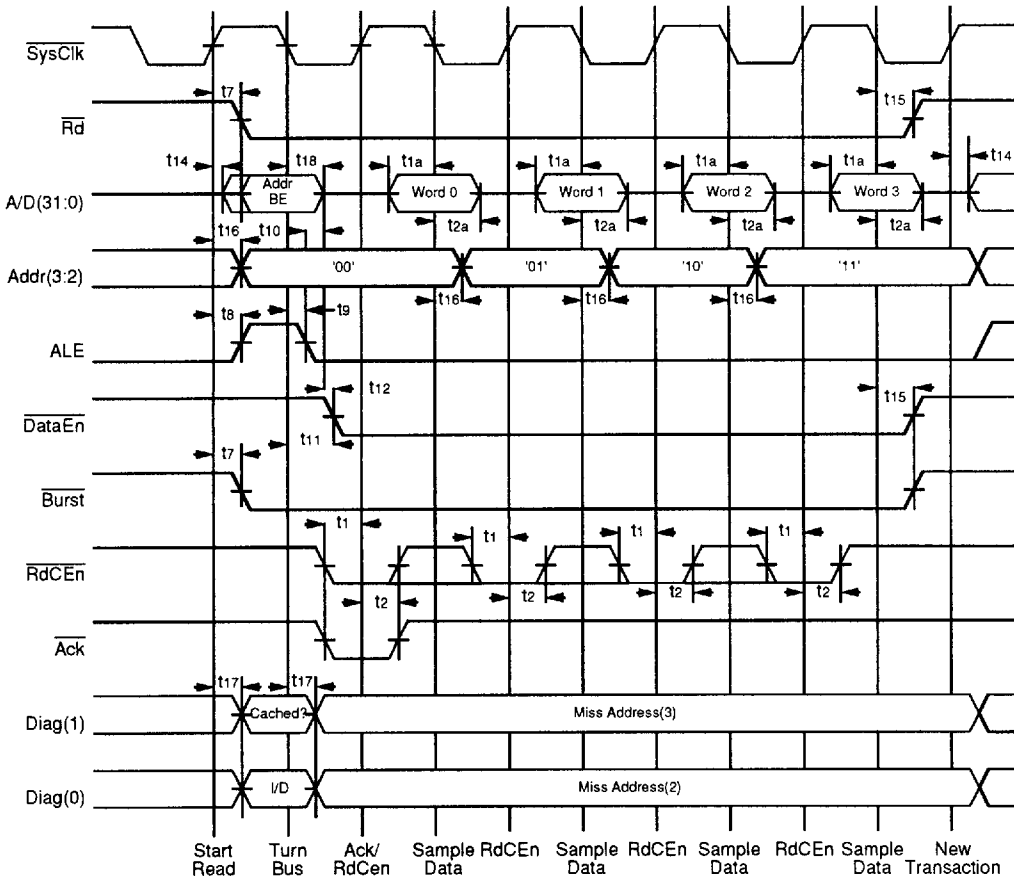

2889 dnr 19

Figure 13. R3081 Burst Read

5



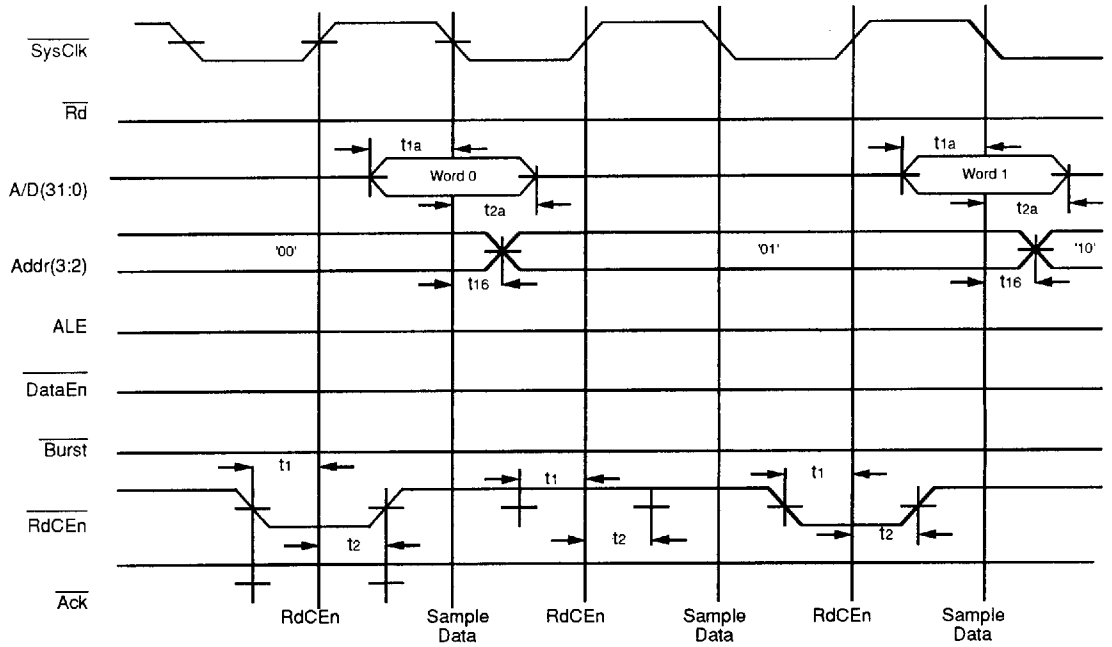

Figure 14 (a). Start of Throttled Quad Read

2889 drw 20

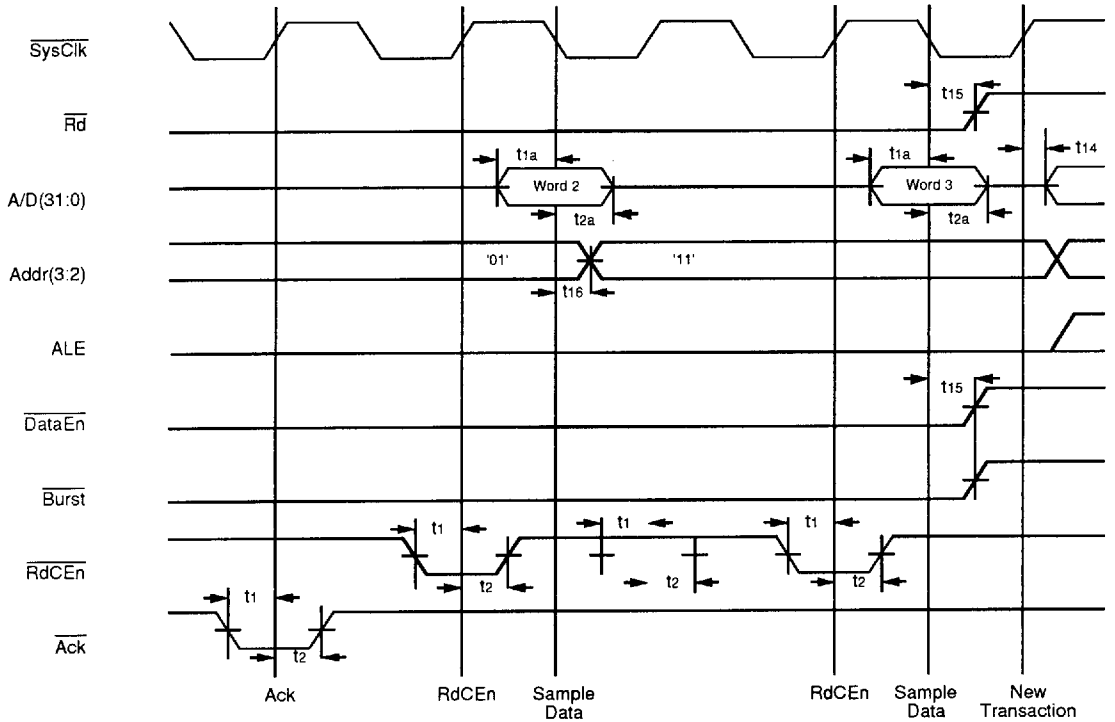

Figure 14 (b). End of Throttled Quad Read

2889 drw 21

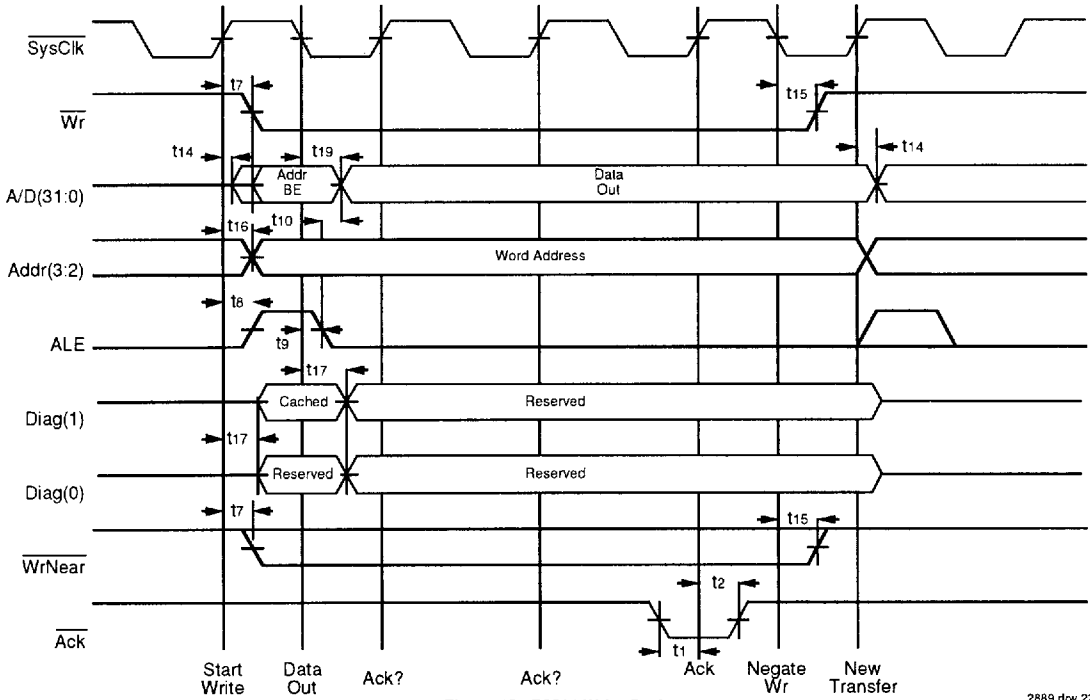

Figure 15. R3081 Write Cycle

2889 drw 22

5



Figure 16. Request and Relinquish of R3081 Bus to External Master

2889 drw 23

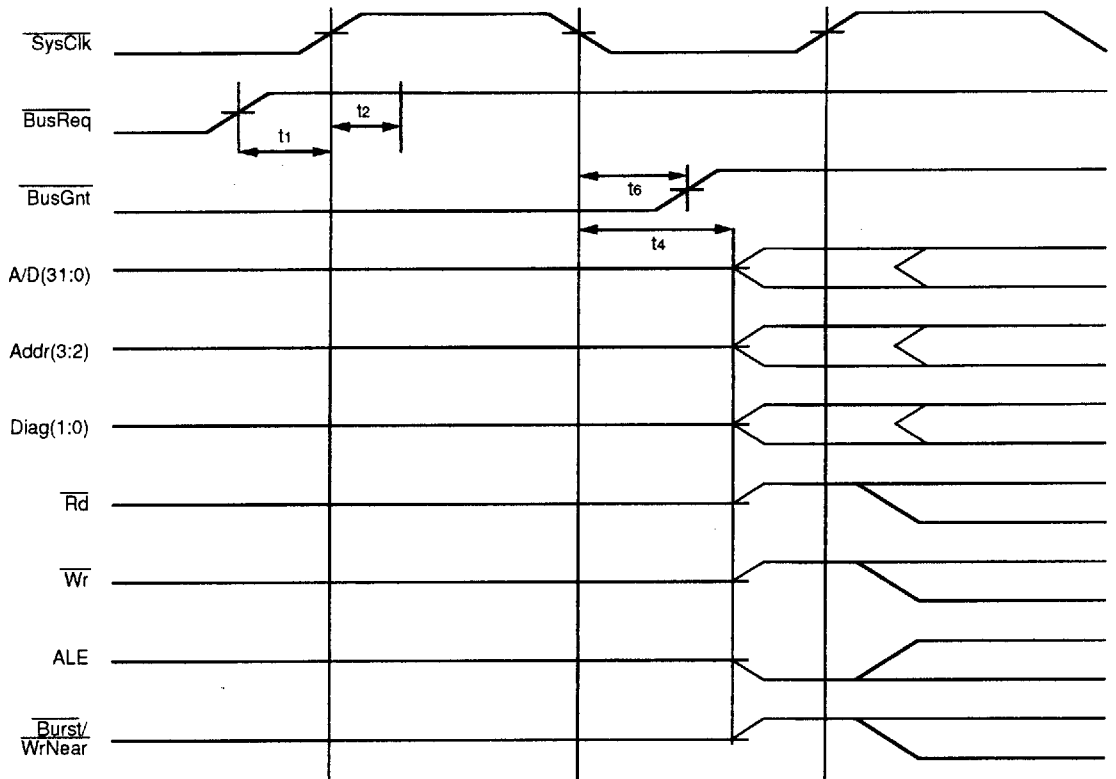

2889 drw 24

Figure 17. R3081 Regaining Bus Mastership

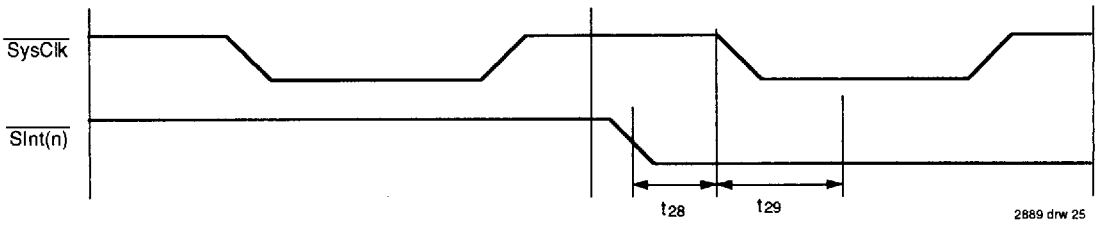

Figure 18. Synchronized Interrupt Input Timing

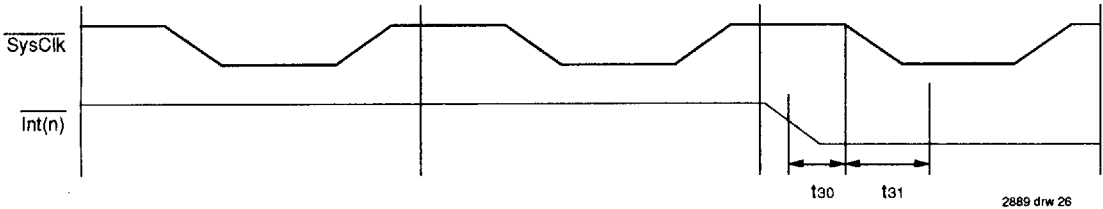

Figure 19. Direct Interrupt Input Timing

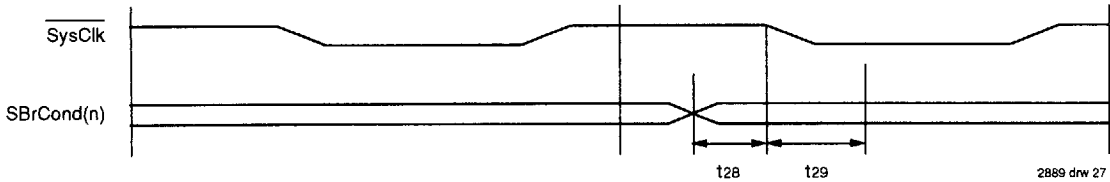

Figure 20. Synchronized Branch Condition Input Timing

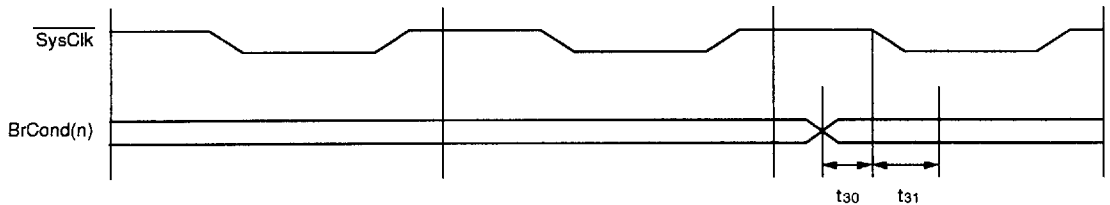
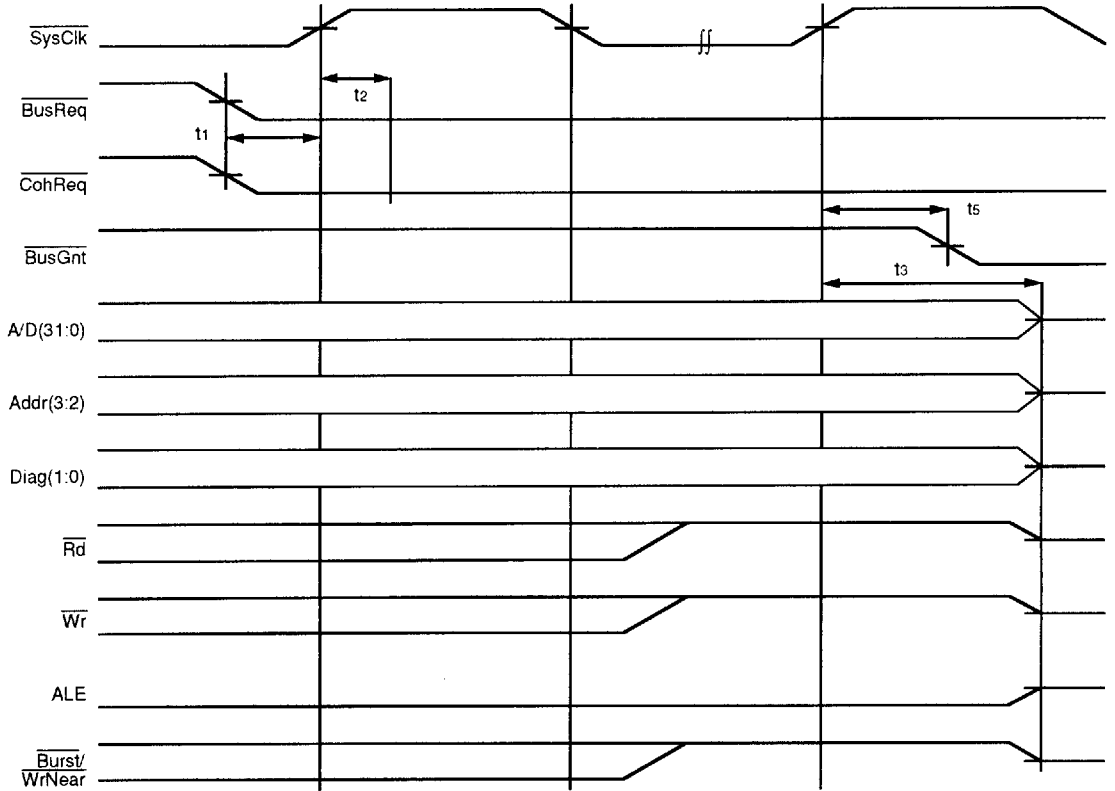

Figure 21. Direct Branch Condition Input Timing

5



2889 drw 29

Figure 22. Coherent DMA Request

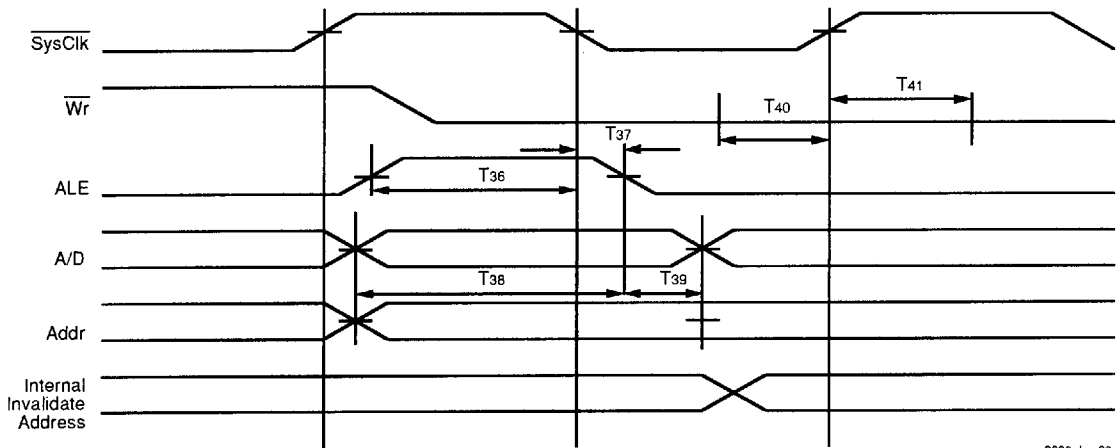

2889 drw 30

Figure 23. Beginning of Coherent DMA Write

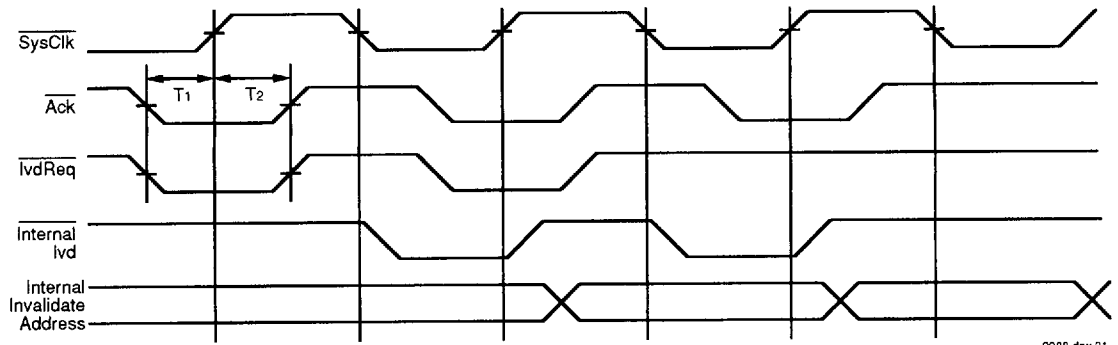

Figure 24. Cache Word Invalidation

2988 drw 31

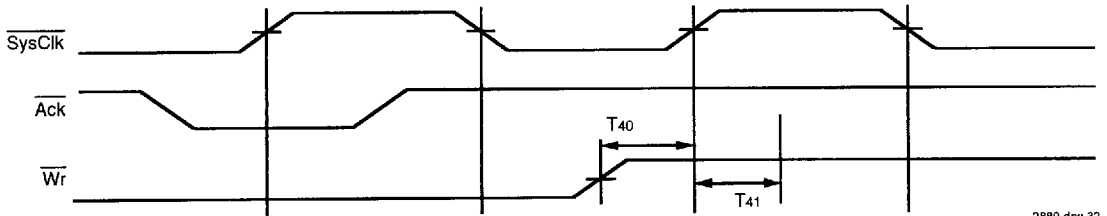

Figure 25. End of Coherent Write

2889 drw 32

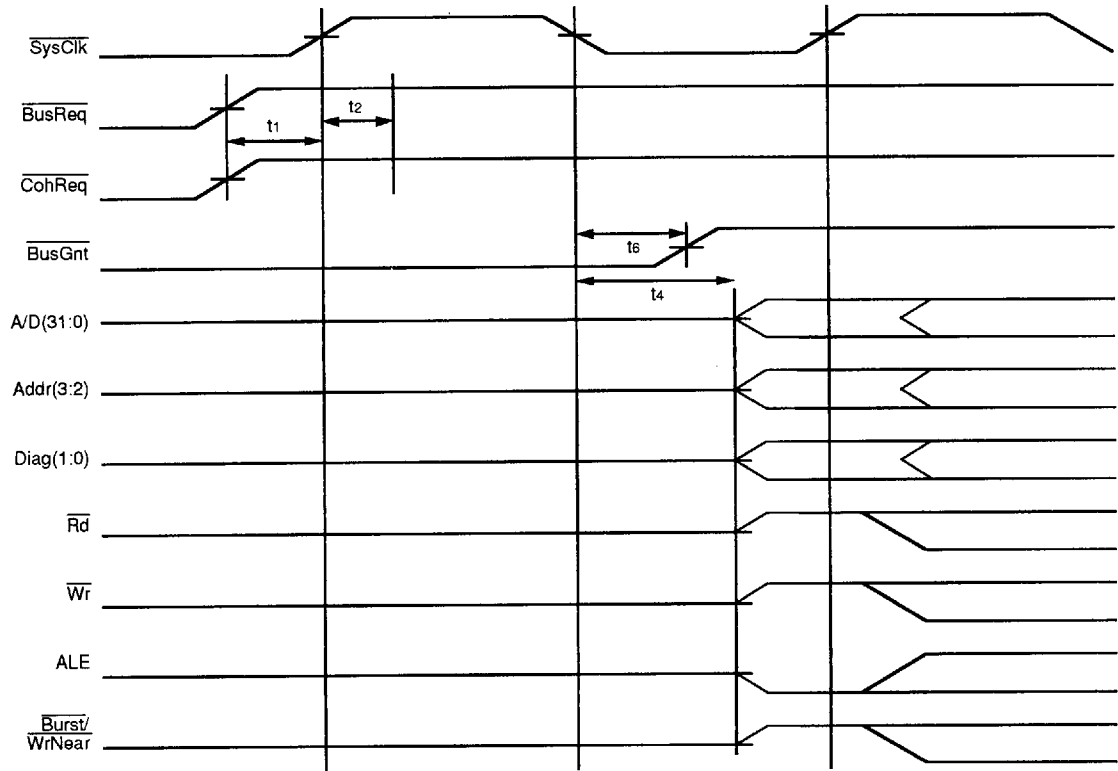
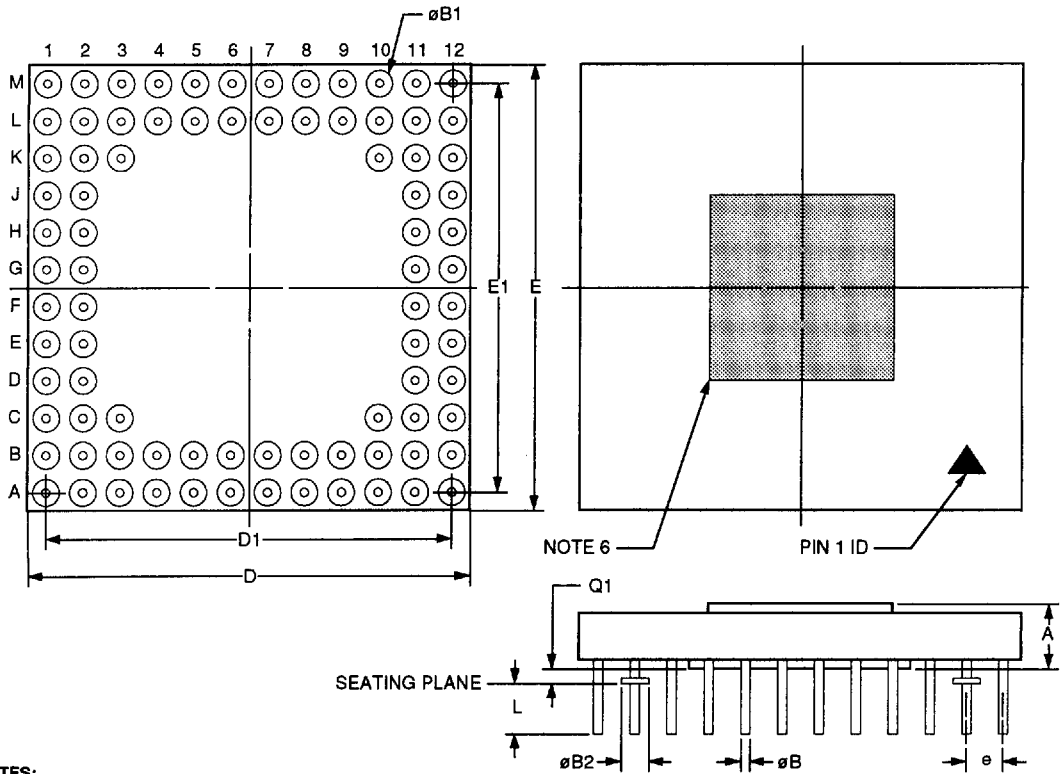

Figure 26. End of Coherent DMA Request

2889 drw 33

5

84-PIN PGA (CAVITY DOWN)



NOTES:

1. All dimensions are in inches, unless otherwise noted.
2. BSC—Basic lead Spacing between Centers
3. Symbol "M" represents the PGA matrix size.
4. Symbol "N" represents the number of pins.
5. Chamfered corners are IDT's option.
6. Shaded area indicates integral metallic heat sink.

2889 drw 34

Drawing #	G84-4	
Symbol	Min	Max
A	.077	.145
$\phi B$	.016	.020
$\phi B1$	.060	.080
$\phi B2$	.040	.060
D/E	1.180	1.235
D1/E1	1.100 BSC	
e	.100 BSC	
L	.120	.140
M	12	
N	84	
Q1	.025	.060

2889 tbl 12

84 LEAD MQUAD<sup>(7)</sup>

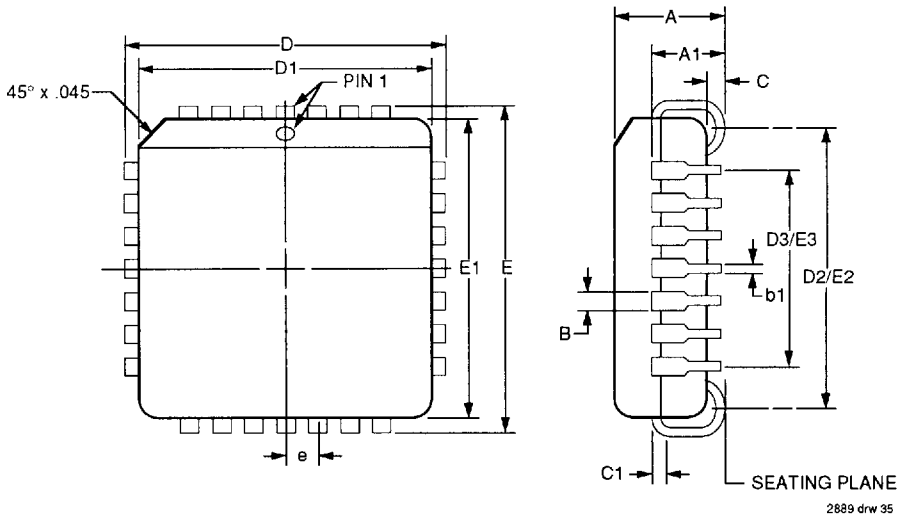

NOTES:

1. All dimensions are in inches, unless otherwise noted.
2. BSC—Basic lead Spacing between Centers.
3. D & E do not include mold flash or protutions.
4. Formed leads shall be planar with respect to one another and within .004" at the seating plane.
5. ND & NE represent the number of leads in the D & E directions respectively.
6. D1 & E1 should be measured from the bottom of the package.
7. 84-pin MQUAD is pin & form compatible with 84-pin PLCC of R3051/2

DWG #	MJ84-1	
# of Leads	84	
Symbol	Min.	Max.
A	.165	.180
A1	.094	.114
B	.026	.032
b1	.013	.021
C	.020	.040
C1	.008	.012
D	1.185	1.195
D1	1.140	1.150
D2/E2	1.090	1.130
D3/E3	1.000 REF	
E	1.185	1.195
E1	1.140	1.150
e	.050 BSC	
ND/NE	21	

2889 tbl 13

5



**ORDERING INFORMATION**

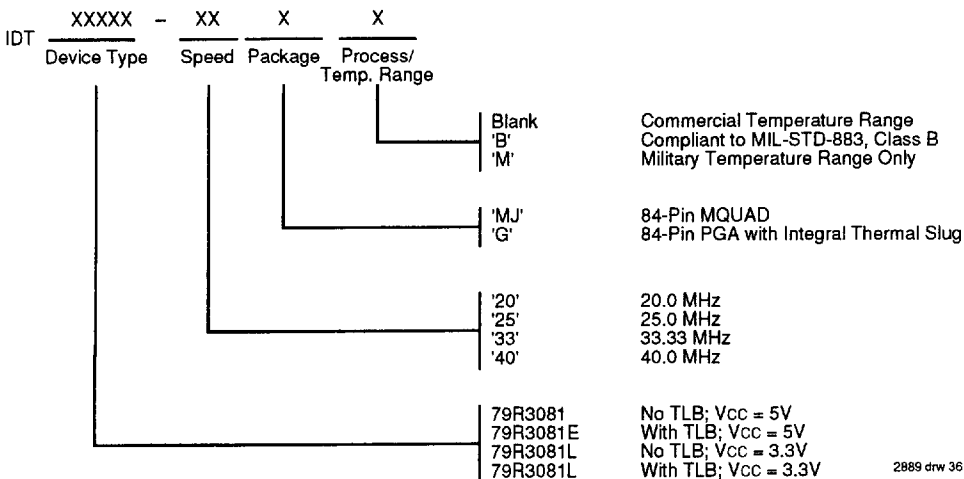

2889 drw 36

**VALID COMBINATIONS**

- |                              |                  |
|------------------------------|------------------|
| IDT 79R3081 - 20, 25, 33, 40 | All packages     |
| 79R3081E - 20, 25, 33, 40    | All packages     |
| 79R3081L - 20, 25, 33, 40    | All packages     |
| 79R3081LE - 20, 25, 33, 40   | All packages     |
| 79R3081M, B - 20, 25         | PGA Package Only |
| 79R3081EM, B - 20, 25        | PGA Package Only |