

## 16M-Bit (1Mx16 /512Kx32) CMOS MASK ROM

### FEATURES

- Switchable organization  
1,048,576 x 16(word mode)  
524,288 x 32(double word mode)
- Fast access time  
Random Access : 100ns(Max.)  
Page Access : 30ns(Max.)  
4 double Words / 8 Words page access
- Supply voltage : single +5V
- Current consumption  
Operating : 150mA(Max.)  
Standby : 50µA(Max.)
- Fully static operation
- All inputs and outputs TTL compatible
- Three state outputs
- Package  
-. K3P5C2000D-SC : 70-SSOP-500

### GENERAL DESCRIPTION

The K3P5C2000D-SC is a fully static mask programmable ROM fabricated using silicon gate CMOS process technology, and is organized either as 1,048,576 x 16 bit(word mode) or is 524,288 x 32 bit(double word mode) depending on WORD voltage level.(See mode selection table)

This device includes page read mode function, page read mode allows 4 double words (or 8 words) of data to read fast in the same page,  $\overline{CE}$  and  $A_2 \sim A_{18}$  should not be changed.

This device operates with a 5V single power supply, and all inputs and outputs are TTL compatible.

Because of its asynchronous operation, it requires no external clock assuring extremely easy operation.

It is suitable for use in program memory of microprocessor, and data memory, character generator. The K3P5C2000D-SC is packaged in a 70-SSOP.

### FUNCTIONAL BLOCK DIAGRAM

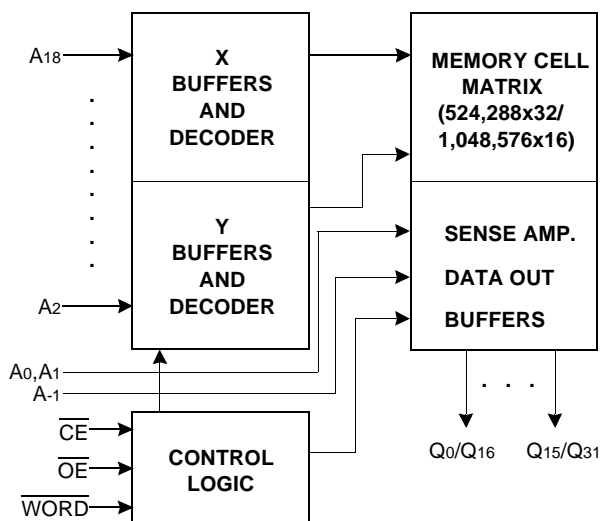

Pin Name	Pin Function
A <sub>0</sub> - A <sub>1</sub>	Page Address Inputs
A <sub>2</sub> - A <sub>18</sub>	Address Inputs
Q <sub>0</sub> - Q <sub>30</sub>	Data Outputs
Q <sub>31</sub> / A-1	Output 31(Double word mode)/ LSB Address(Word mode)
$\overline{WORD}$	Double word/Word mode selection
$\overline{CE}$	Chip Enable
$\overline{OE}$	Output Enable
V <sub>cc</sub>	Power (+5V)
V <sub>ss</sub>	Ground
N.C	No Connection

### PIN CONFIGURATION

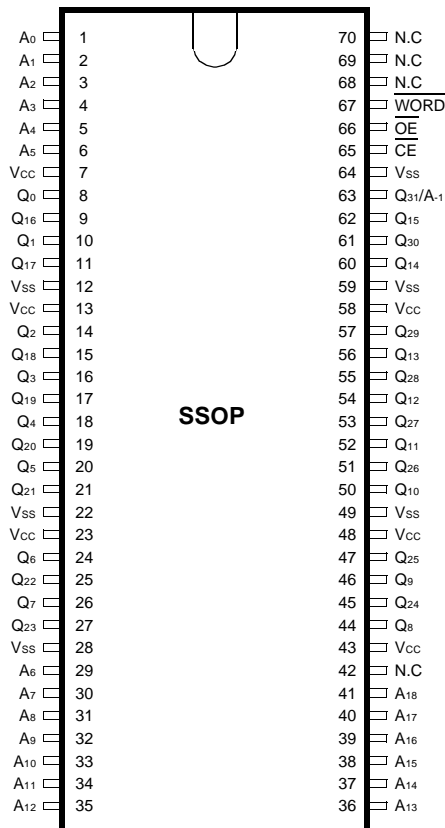

K3P5C2000D-SC

## ABSOLUTE MAXIMUM RATINGS

Item	Symbol	Rating	Unit
Voltage on Any Pin Relative to V <sub>SS</sub>	V <sub>IN</sub>	-0.3 to +7.0	V
Temperature Under Bias	T <sub>BIAS</sub>	-10 to +85	°C
Storage Temperature	T <sub>STG</sub>	-55 to +150	°C

**NOTE** : Permanent device damage may occur if "ABSOLUTE MAXIMUM RATINGS" are exceeded. Functional operation should be restricted to the conditions as detailed in the operational sections of this data sheet. Exposure to absolute maximum rating conditions for extended periods may affect device reliability.

RECOMMENDED OPERATING CONDITIONS (Voltage reference to V<sub>SS</sub>, T<sub>A</sub>=0 to 70°C)

Item	Symbol	Min	Typ	Max	Unit
Supply Voltage	V <sub>CC</sub>	4.5	5.0	5.5	V
Supply Voltage	V <sub>SS</sub>	0	0	0	V

## DC CHARACTERISTICS

Parameter	Symbol	Test Conditions	Min	Max	Unit
Operating Current	I <sub>CC</sub>	Cycle=5MHz, all outputs open $\overline{CE}=\overline{OE}=V_{IL}$ , V <sub>IN</sub> =0.6V to 2.4V (AC Test Condition)	-	150	mA
Standby Current(TTL)	I <sub>SB1</sub>	$\overline{CE}=V_{IH}$ , all outputs open	-	1	mA
Standby Current(CMOS)	I <sub>SB2</sub>	$\overline{CE}=V_{CC}$ , all outputs open	-	50	μA
Input Leakage Current	I <sub>LI</sub>	V <sub>IN</sub> =0 to V <sub>CC</sub>	-	10	μA
Output Leakage Current	I <sub>LO</sub>	V <sub>OUT</sub> =0 to V <sub>CC</sub>	-	10	μA
Input High Voltage, All Inputs	V <sub>IH</sub>		2.2	V <sub>CC</sub> +0.3	V
Input Low Voltage, All Inputs	V <sub>IL</sub>		-0.3	0.8	V
Output High Voltage Level	V <sub>OH</sub>	I <sub>OH</sub> =-400μA	2.4	-	V
Output Low Voltage Level	V <sub>OL</sub>	I <sub>OL</sub> =2.1mA	-	0.4	V

**NOTE** : Minimum DC Voltage(V<sub>IL</sub>) is -0.3V on input pins. During transitions, this level may undershoot to -2.0V for periods <20ns.  
Maximum DC voltage on input pins(V<sub>IH</sub>) is V<sub>CC</sub>+0.3V which, during transitions, may overshoot to V<sub>CC</sub>+2.0V for periods <20ns.

## MODE SELECTION

$\overline{CE}$	$\overline{OE}$	WORD	Q <sub>31/A-1</sub>	Mode	Data	Power
H	X	X	X	Standby	High-Z	Standby
L	H	X	X	Operating	High-Z	Active
L	L	H	Output	Operating	Q <sub>0</sub> -Q <sub>31</sub> :Dout	Active
		L	Input	Operating	Q <sub>0</sub> -Q <sub>15</sub> : Dout Q <sub>16</sub> -Q <sub>30</sub> : Hi-Z	Active

CAPACITANCE (T<sub>A</sub>=25°C, f=1.0MHz)

Item	Symbol	Test Conditions	Min	Max	Unit
Output Capacitance	C <sub>OUT</sub>	V <sub>OUT</sub> =0V	-	12	pF
Input Capacitance	C <sub>IN</sub>	V <sub>IN</sub> =0V	-	12	pF

**NOTE** : Capacitance is periodically sampled and not 100% tested.



**AC CHARACTERISTICS**( $T_A=0^{\circ}\text{C}$  to  $70^{\circ}\text{C}$ ,  $V_{CC}=5\text{V}\pm 10\%$ , unless otherwise noted.)**TEST CONDITIONS**

Item	Value
Input Pulse Levels	0.6V to 2.4V
Input Rise and Fall Times	10ns
Input and Output timing Levels	0.8V and 2.0V
Output Loads	1 TTL Gate and $C_L=100\text{pF}$

**READ CYCLE**

Item	Symbol	K3P5C2000D-SC10		K3P5C2000D-SC12		K3P5C2000D-SC15		Unit
		Min	Max	Min	Max	Min	Max	
Read Cycle Time	t <sub>RC</sub>	100		120		150		ns
Chip Enable Access Time	t <sub>ACE</sub>		100		120		150	ns
Address Access Time	t <sub>AA</sub>		100		120		150	ns
Page Address Access Time	t <sub>PA</sub>		30		50		70	ns
Output Enable Access Time	t <sub>OE</sub>		30		50		70	ns
Output or Chip Disable to Output High-Z	t <sub>DF</sub>		20		20		30	ns
Output Hold from Address Change	t <sub>OH</sub>	0		0		0		ns

**NOTE** : Page Address is determined as below.  
 Double Word mode (WORD=V<sub>IH</sub>) : A<sub>0</sub>, A<sub>1</sub>  
 Word mode (WORD=V<sub>IL</sub>) : A<sub>-1</sub>, A<sub>0</sub>, A<sub>1</sub>

TIMING DIAGRAM

READ

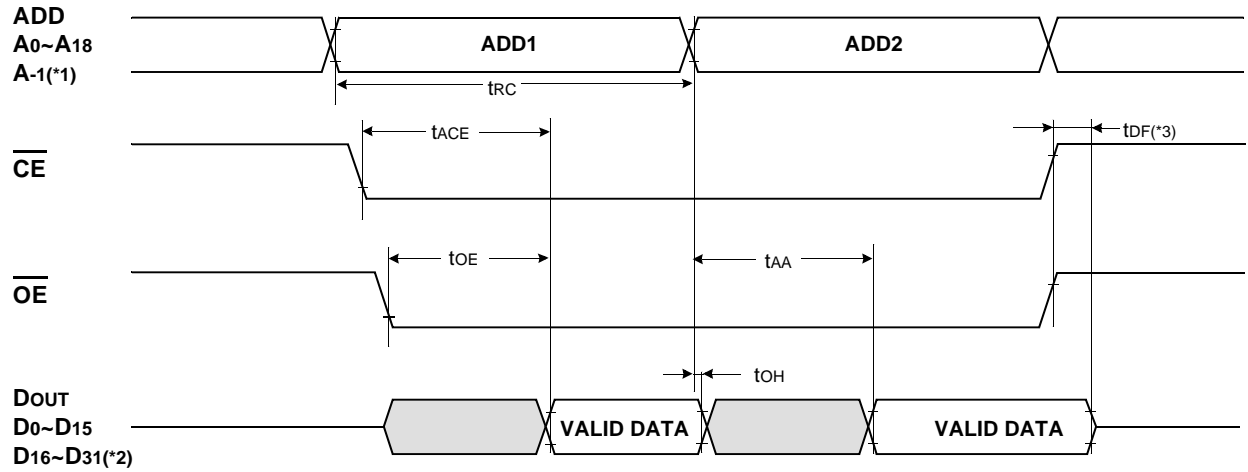

PAGE READ

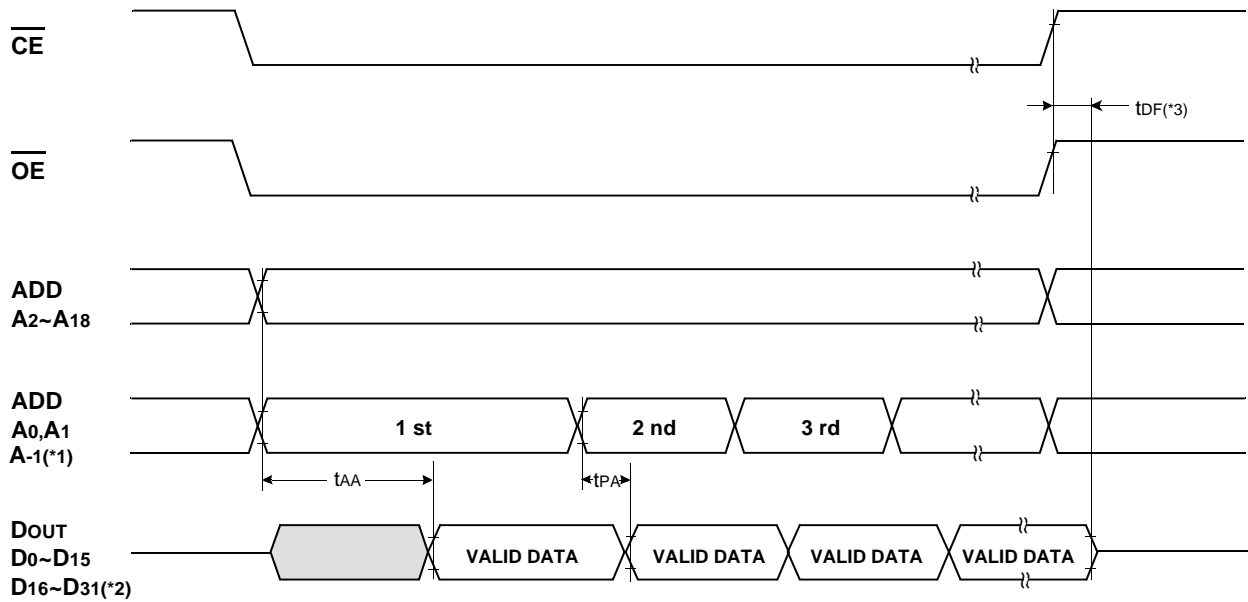

NOTES :

\*1. Word Mode only. A-1 is Least Significant Bit Address. ( $\overline{\text{WORD}} = V_{IL}$ )

\*2. Double Word Mode only. ( $\overline{\text{WORD}} = V_{IH}$ )

\*3. tDF is defined as the time at which the outputs achieve the open circuit condition and is not referenced to  $V_{OH}$  or  $V_{OL}$  level.

