

General Description

The AAT3183 is a high efficiency step-down charge pump converter providing up to 300mA of output current. The 1/2x (gain) charge pump converter topology provides enhanced efficiency over conventional LDO regulators and requires only three low cost ceramic capacitors. No inductor is required; saving space and cost when compared to inductive switching regulators.

The AAT3183 typically consumes 35µA of no load (zero output current) quiescent current, making it ideal for portable battery powered systems. Shutdown current is less than 1µA.

The AAT3183 soft-start prevents excessive inrush current while providing monotonic turn-on characteristics. The device includes integrated short-circuit and over-temperature (thermal) protection to safeguard system components.

The AAT3183 is available in a Pb-free 2.0x2.1mm SC70JW-8 package. Operating temperature range is -40°C to +85°C.

Features

- V_{IN} Range: 2.7V to 5.5V
- V_{OUT} : 1.5V
- 300mA Maximum Output Current
- Ultra-Small Solution for Portable Applications
 - Small Footprint
 - Only Three External Ceramic Capacitors Required
 - No Inductor
- High Efficiency over the Output Current Range
- Excellent Transient Performance
- 35µA Typical Quiescent Current
- <1.0µA Shutdown Current
- Up to 2MHz Switching Frequency
- Integrated Soft-Start
- Short-Circuit and Thermal Protection
- 2.0x2.1mm SC70JW-8 Package
- -40°C to 85°C Temperature Range

Applications

- Camcorders
- Digital Still Cameras
- DSP Core Supplies
- PDAs, Handheld Devices, Notebook PCs
- Smart Phones

Typical Application

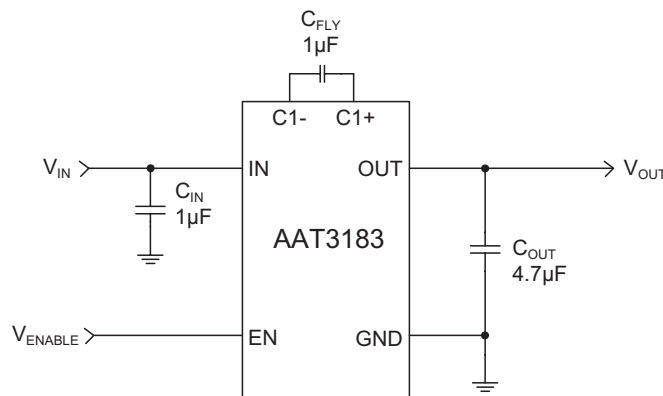

Pin Descriptions

Pin #	Symbol	Function
1	OUT	Charge pump converter output. Requires a ceramic capacitor to ground.
2	C1+	Flying capacitor positive terminal. Connect flying capacitor between C1+ and C1-.
3	C1-	Flying capacitor negative terminal. Connect flying capacitor between C1+ and C1-.
4	IN	Charge pump converter input. Requires a ceramic capacitor to ground.
5	EN	Enable pin. Active high.
6, 7, 8	GND	Ground.

Pin Configuration

SC70JW-8
(Top View)

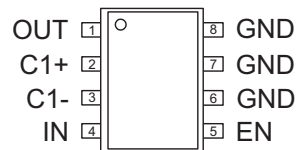

Absolute Maximum Ratings¹

Symbol	Description	Value	Units
V _{IN}	Input Voltage to Ground	-0.3 to 6.0	V
V _{EN}	Enable Voltage to Ground	-0.3 to 6.0	V
T _J	Operating Junction Temperature Range ²	-40 to 150	°C
T _S	Storage Temperature Range	-65 to 150	°C
T _{LEAD}	Maximum Soldering Temperature (at leads, 10 sec)	300	°C

Thermal Information

Symbol	Description	Value	Units
θ _{JA}	Thermal Resistance ³	160	°C/W
P _D	Maximum Power Dissipation at T _A = 25°C	625	mW

1. Stresses above those listed in Absolute Maximum Ratings may cause permanent damage to the device. Functional operation at conditions other than the operating conditions specified is not implied. Only one Absolute Maximum Rating should be applied at any one time.
2. T_J is calculated from the ambient temperature T_A and power dissipation P_D according to the following formula: T_J = T_A + P_D × θ_{JA}.
3. Mounted on an FR4 board.

Electrical Characteristics¹

$V_{IN} = 3.6V$, $C_{IN} = C_{FLY} = 1.0\mu F$, $C_{OUT} = 4.7\mu F$, $T_A = -40^{\circ}C$ to $+85^{\circ}C$, unless otherwise noted. Typical values are at $T_A = 25^{\circ}C$.

Symbol	Description	Conditions	Min	Typ	Max	Units
V_{IN}	Input Voltage		2.7		5.5	V
V_{OUT}	Output Voltage Accuracy	No Load, $T_A = 25^{\circ}C$	1.485	1.500	1.515	V
		No Load	1.470	1.500	1.530	
V_{UVLO}	Under-Voltage Lockout (UVLO)	V_{IN} Rising		1.5	2	V
		Hysteresis		0.15		
		V_{IN} Falling	1.3			
I_{OUT}	Output Current				300	mA
I_Q	Quiescent Current	$V_{EN} = V_{IN}$, No Load		35	60	μA
	Shutdown Current	$V_{EN} = GND$			1	
V_{PP}	Output Voltage Ripple	$I_{OUT} = 300mA$		12		mV
		$I_{OUT} = 150mA$		16		
		$I_{OUT} = 100mA$		17		
		$I_{OUT} = 10mA$		17		
$\frac{\Delta V_{OUT}}{\Delta V_{IN}}$	Line Regulation	$3.2V \leq V_{IN} \leq 5.5V$, $I_{OUT} = 50mA$		2.9		mV/V
$\frac{\Delta V_{OUT}}{\Delta I_{OUT}}$	Load Regulation	$0mA \leq I_{OUT} \leq 150mA$		0.053		mV/mA
T_{SS}	Soft-Start Time			100		μs
F_{CLK}	Clock Frequency	$I_{OUT} = 300mA$		2		MHz
$V_{EN(L)}$	Enable Threshold Low				0.4	V
$V_{EN(H)}$	Enable Threshold High		1.4			V
I_{EN}	EN Input Leakage				1	μA
R_{OUT}	Output Impedance			1		Ω
T_{SD}	Over-Temperature Shutdown Threshold			150		$^{\circ}C$
T_{HYS}	Over-Temperature Shutdown Hysteresis			15		$^{\circ}C$

1. The AAT3183 is guaranteed to meet performance specifications over the $-40^{\circ}C$ to $+85^{\circ}C$ operating temperature range and is assured by design, characterization, and correlation with statistical process controls.

Typical Characteristics

Efficiency vs. Output Current
($V_{OUT} = 1.5V$)

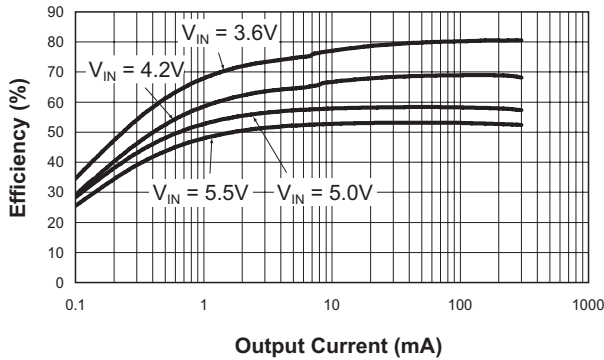

Output Error vs. Output Current
($V_{OUT} = 1.5V$)

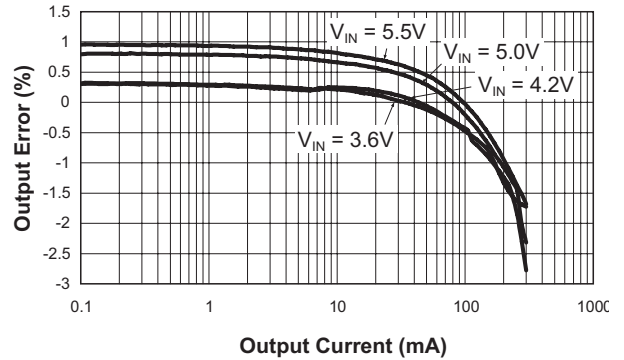

Output Voltage Error vs. Temperature
($V_{IN} = 3.6V$; $V_{OUT} = 1.5V$; $I_{OUT} = 150mA$)

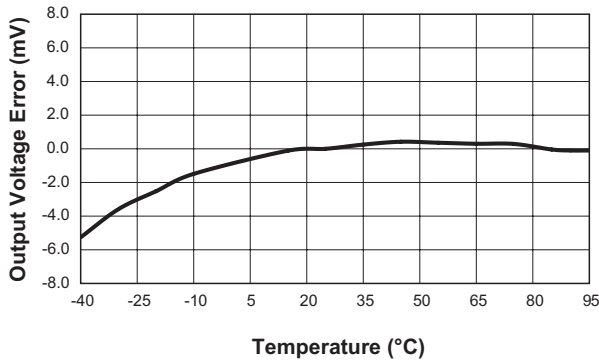

Efficiency vs. Input Voltage
($V_{OUT} = 1.5V$)

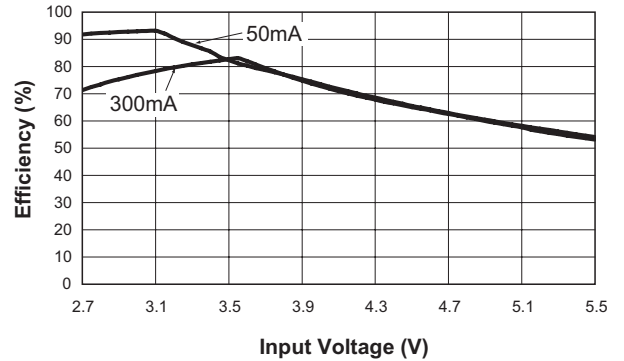

Output Error vs. Input Voltage
($V_{OUT} = 1.5V$)

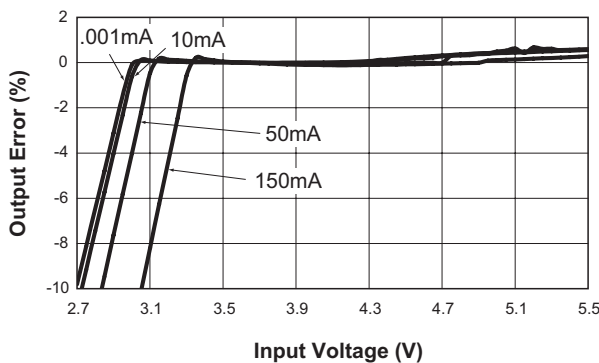

No Load Quiescent Current vs. Input Voltage
($V_{OUT} = 1.5V$; No Load)

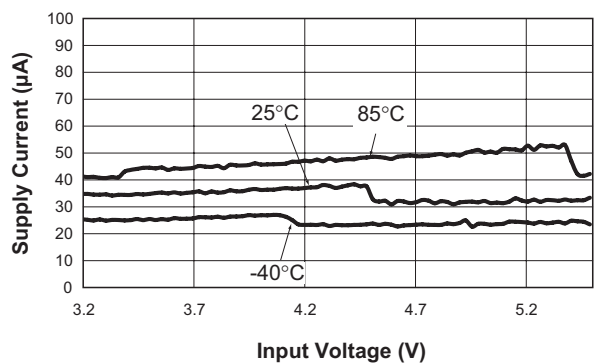

Typical Characteristics

Output Voltage Ripple vs. Input Voltage
($C_{IN}/C_{FLY} = 1\mu F$; $C_{OUT} = 4.7\mu F$; $I_{OUT} = 300mA$)

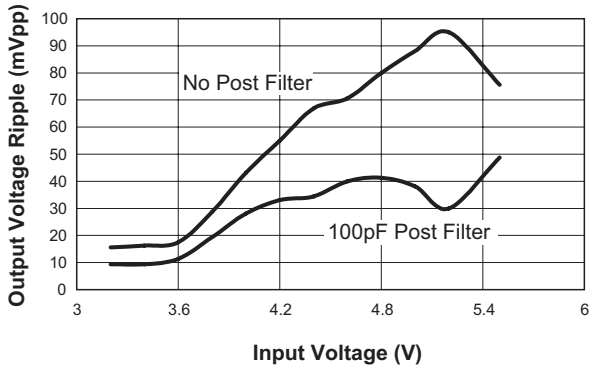

Output Impedance vs. Input Voltage

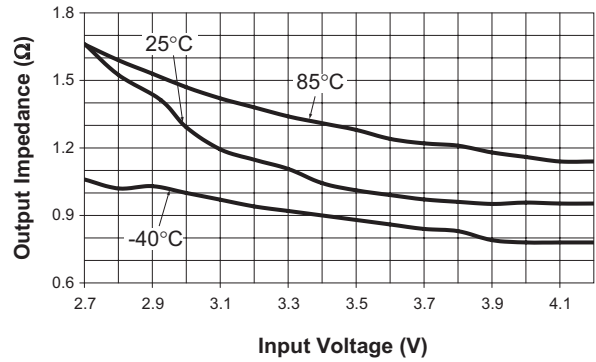

Load Transient Response
($V_{IN} = 3.6V$; $V_{OUT} = 1.5V$; $I_{OUT} = 5mA$ to $150mA$)

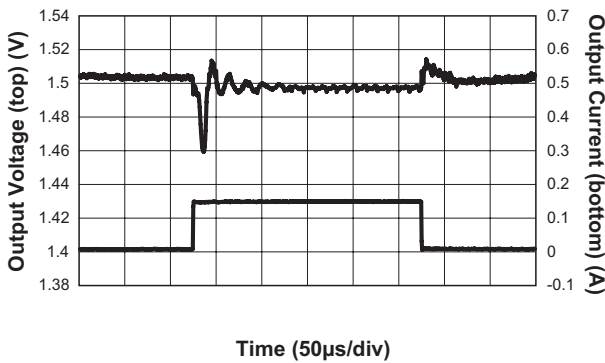

Line Transient
($V_{IN} = 3.6V$ to $4.2V$)

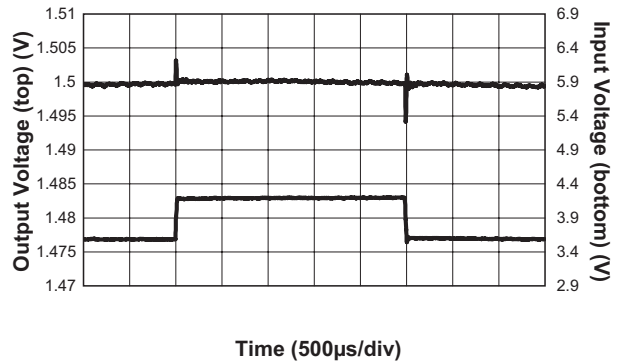

Output Ripple
($V_{OUT} = 1.5V$; $I_{OUT} = 300mA$)

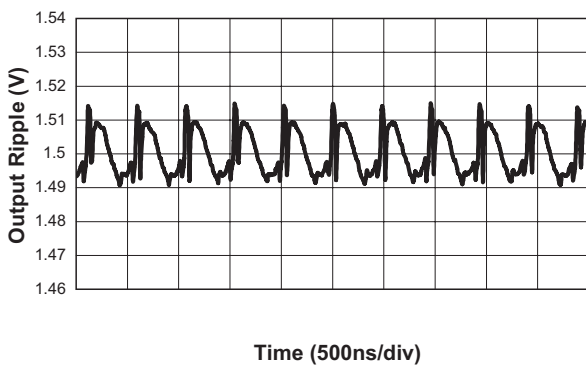

Output Ripple
($V_{OUT} = 1.5V$; $I_{OUT} = 150mA$)

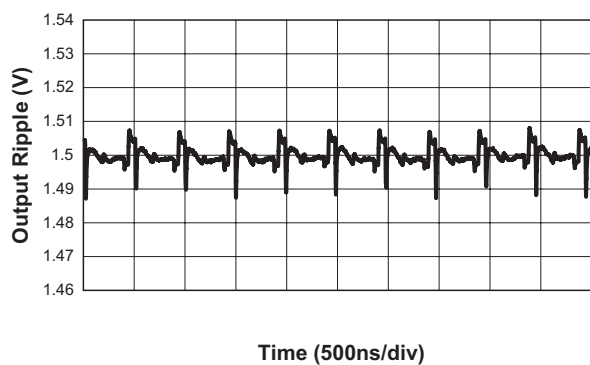

Typical Characteristics

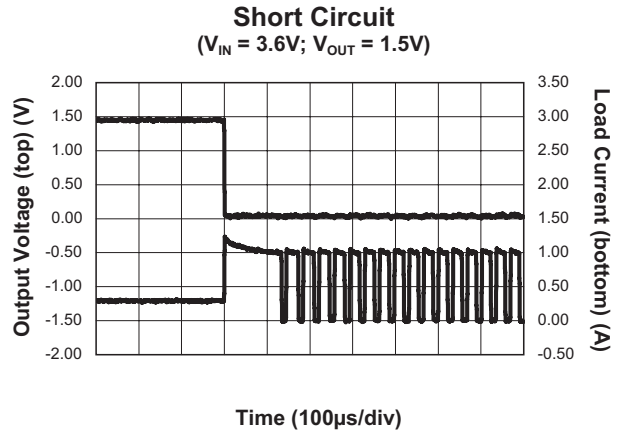
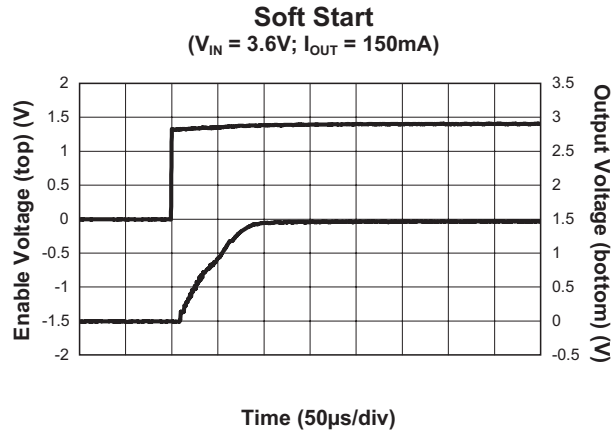

Functional Block Diagram

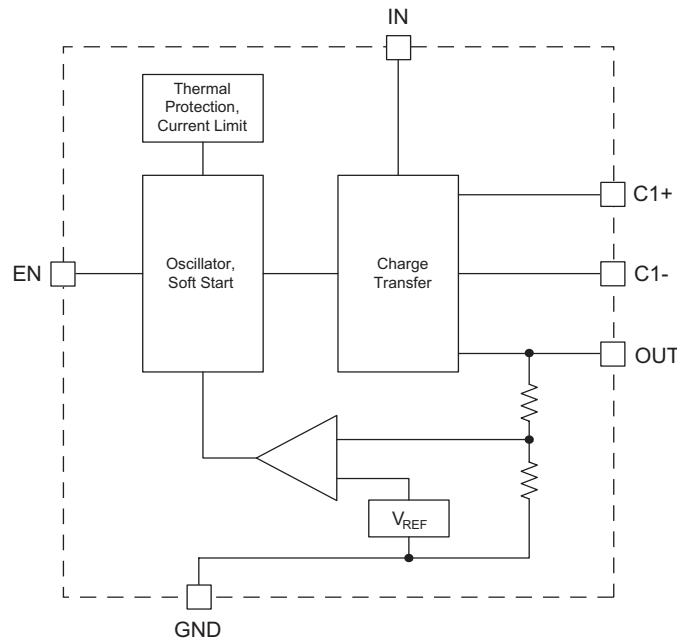

Functional Description

The AAT3183 is a 1/2x (gain) charge pump converter providing an output voltage which is less than the input voltage. The step-down (buck) charge pump converter provides a regulated output voltage for input voltages greater than 2x the output voltage plus the required input voltage headroom (see the Applications Information section for more details). The output current range is 0mA (no load) to 300mA.

The AAT3183 provides an ultra-small DC-DC solution achieving improved efficiency over LDO step-down regulators. The high switching frequency allows the use of small external capacitors. Only three ceramic capacitors are required to achieve a complete step-down converter solution.

Output regulation is maintained with a pulse frequency modulation (PFM) control scheme. PFM compensates for input voltage and output current variations by modulating the frequency of charge

pump switching intervals. Switching frequency increases with high output currents (heavy loads) and decreases with low output currents (light loads); with a maximum switching frequency of 2MHz. PFM control provides decreased switching losses and increased efficiency with light loads. This extends battery life under lightly loaded operating conditions.

The AAT3183 responds quickly to changes in line voltage and/or output current, providing stable operation with excellent line and load transient behavior.

No load (zero output current) quiescent current is 35 μ A (typical). When disabled, the device consumes less than 1 μ A of current (shutdown).

Integrated soft-start limits inrush current, maintains monotonic turn-on characteristics and eliminates output voltage overshoot. The device includes short-circuit protection and a self-recovering over-temperature (thermal) protection.

Charge Pump Operation

The AAT3183 step-down charge pump is implemented using a fixed 1/2x (gain) converter topology. This configuration allows efficient energy transfer with a single ceramic flying capacitor. The arrangement of the internal switches requires that the voltage on the flying capacitor is greater than the output voltage plus the input voltage headroom to account for a parasitic voltage drop.

Energy is transferred to the flying capacitor and output during alternate 'charge' and 'discharge' intervals. The amount of energy transferred from the input voltage source to flying capacitor is proportional to the differential voltage across the flying capacitor ($V_{DIFF} = V_{IN} - V_{OUT}$) which occurs during the 'charge' interval multiplied by the switching frequency. The step-down charge pump transfers energy to the output during both the 'charge' and 'discharge' intervals. Figure 1 illustrates the energy transfer mechanism during 'charge' and 'discharge' intervals.

PFM control compensates for changes in the input voltage and output current by modulating the frequency of switching intervals to maintain the desired output voltage. The output voltage is sensed through an internal resistor divider and compared against a reference voltage by an error amplifier. As the output voltage decreases, the voltage at the input to the error amplifier decreases.

es. The error signal increases the effective switching frequency; providing increased current to the output current thus maintaining the desired output voltage. At light loads, the effective switching frequency is greatly reduced which maintains output regulation while minimizing switching losses.

Operating efficiency (η) is defined as the output power divided by the input power.

$$\eta = \frac{P_{OUT}}{P_{IN}} = \frac{(V_{OUT} \cdot I_{OUT})}{(V_{IN} \cdot I_{IN})}$$

With a constant output current and 1/2x (gain) operation, the input current is constant regardless of input voltage. The input current is equal to 50% [1/2x (gain)] of the output current.

$$I_{IN} = \frac{1}{2} I_{OUT}$$

$$\eta = \frac{(V_{OUT} \cdot I_{OUT})}{(V_{IN} \cdot \frac{1}{2} I_{OUT})} = \frac{2 \cdot V_{OUT}}{V_{IN}}$$

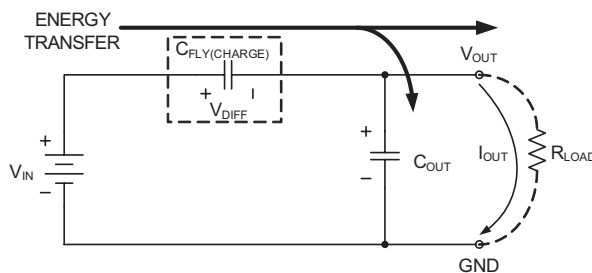

Figure 1a: Step-Down Charge Pump "CHARGE" Interval.

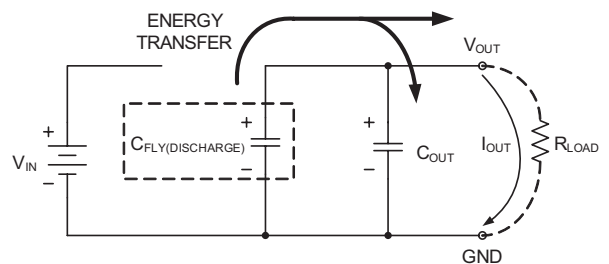

Figure 1b: Step-Down Charge Pump "DISCHARGE" Interval.

A conventional LDO regulator maintains input current which is equal to the output current. Operation efficiency (η) of an LDO regulator is as follows:

$$\begin{aligned} \eta &= \frac{P_{IN}}{P_{OUT}} \\ &= \frac{(V_{OUT} \cdot I_{OUT})}{(V_{IN} \cdot I_{IN})} \\ I_{IN} &= I_{OUT} \\ \eta &= \frac{(V_{OUT} \cdot I_{OUT})}{(V_{IN} \cdot I_{OUT})} \\ &= \frac{V_{OUT}}{V_{IN}} \end{aligned}$$

Therefore, the AAT3183 provides a 100% efficiency improvement over conventional LDO regulators; as illustrated in Figure 2.

Efficiency vs. Output Current
($V_{IN} = 3.6V$; $V_{OUT} = 1.5V$)

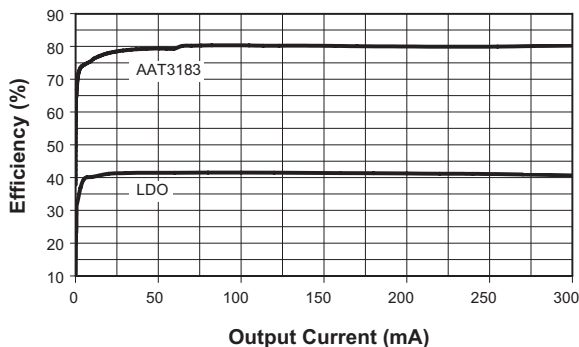

Figure 2: AAT3183 Efficiency Comparison vs. LDO.

Under-Voltage Lockout

Under-voltage lockout (UVLO) circuitry monitors the input voltage (V_{IN}) and ensures that the device will remain in standby ($V_{OUT} = 0V$) until a valid V_{IN} is present. When V_{IN} is less than 1.5V (typical), the input current is less than $1\mu A$ and the output voltage (V_{OUT}) remains at 0V, regardless of the status of the enable pin (EN). Typically, the UVLO turn-on thresh-

old is 150mV greater than the UVLO turn-off threshold. UVLO hysteresis minimizes spurious under-voltage detection and eliminates output glitches.

Shutdown and Soft-Start

The AAT3183 offers an enable pin (EN). When V_{EN} is below 0.4V (maximum), the device is in standby (shutdown) mode and draws less than $1\mu A$ of input current. The output will remain at 0V when EN voltage is low ($V_{EN} \leq 0.4V$). When EN is connected to a voltage greater than 1.4V (minimum), the AAT3183 will initiate soft-start and resume normal operation.

The product features built-in soft-start circuitry to reduce inrush current and eliminate output voltage overshoot. The soft-start circuitry is enabled when input UVLO conditions are satisfied and the EN voltage is high ($V_{EN} \geq 1.4V$). If EN is tied to IN, the soft start is initiated when UVLO conditions are satisfied. The soft-start circuitry ramps up the output voltage in a controlled manner and minimizes output overshoot. Start-up time from EN positive transitioning ($V_{EN}: \leq 0.4V$ to $\geq 1.4V$) to output (V_{OUT}) in regulation is 100 μs (typical).

Thermal and Short-Circuit Protection

High device temperature may result at elevated ambient temperatures or in cases where high output current causes self heating of the device. The device will disable all switching of the charge pump when the internal junction temperature exceeds 150°C (typical). The device will restart and enable the soft-start sequence when the temperature is reduced 15°C. This hysteresis ensures that the absolute device temperature is maintained below the over-temperature threshold and protects the device from damage.

In the event of a short circuit, an internal current limit is activated and limits the output current to 1A (typical). This current is maintained until the output fault condition is removed or device over-temperature is reached. Under sustained short-circuit conditions, the device will typically reach over-temperature and latch off. The device will cool down after a short period and continue to oscillate between active and over-temperature protection states until the fault is removed. Under these worst case conditions, the device average junction temperature will be less than 150°C.

Applications Information

Input Voltage Headroom

The input voltage headroom is the required minimum input voltage in excess of 2x the output voltage. The following equation can be used to calculate the required input voltage headroom:

$$V_{HR} = \frac{(I_{OUT} \cdot R_{OUT})}{M}$$

V_{HR} : Input Voltage Headroom

I_{OUT} : Output Current

R_{OUT} : Output Impedance (see “Output Impedance vs. Input Voltage” performance graph in the “Typical Characteristics” section of this datasheet)

M: Charge Pump Gain
[AAT3183: ½]

Design Example:

AAT3183 Application Conditions:

$I_{OUT} = 200\text{mA}$ (max)

$V_{OUT} = 1.5\text{V}$

What is the required minimum input voltage?

Analysis:

Minimum Input Voltage: $V_{IN(MIN)} = V_{HR} + 2 \cdot V_{OUT}$

$$\begin{aligned} \text{Input Voltage Headroom: } V_{HR} &= \frac{(I_{OUT} \cdot R_{OUT})}{M} \\ &= \frac{(0.2\text{A} \cdot 1)}{\frac{1}{2}} = 0.4\text{V} \end{aligned}$$

Output Voltage: $V_{OUT} = 1.5\text{V}$

Minimum Input Voltage:
 $V_{IN(MIN)} = 0.4\text{V} + 2 \cdot 1.5\text{V} = 3.4\text{V}$

Solution:

The required minimum input voltage is 3.4V.

Capacitor Selection

The AAT3183 requires three external capacitors; C_{IN} , C_{FLY} and C_{OUT} . The capacitor size and type can have a significant impact on charge pump performance, including input and output ripple, stability and operating efficiency.

Surface-mount X5R multi-layer ceramic (MLC) capacitors are a suitable choice due to their small size and $\pm 15\%$ capacitance tolerance over the operating temperature range -55°C to $+85^\circ\text{C}$. X7R MLC capacitors provide similar performance over the extended temperature range -55°C to $+125^\circ\text{C}$. Initial tolerance of $\pm 10\%$ is recommended. MLC capacitors offer superior size (high energy density), low equivalent series resistance (ESR), and low equivalent series inductance (ESL) when compared to tantalum and aluminum electrolytic capacitor varieties. In addition, MLC capacitors are not polarized which simplifies placement on the printed circuit board.

Negligible circuit losses and fast charge/discharge rates are possible with MLC capacitors due to their low ESR, which is typically less than $10\text{m}\Omega$. Switching noise is minimized due to their low ESL which produces voltage spikes due to the fast switching current events in charge pump converters. ESL is typically less than 1nH in MLC capacitors.

MLC capacitance is reduced with an increasing DC bias voltage. Capacitance derating varies with case size, voltage rating and vendor. It is recommended that circuit performance, including output current capability and input/output voltage ripple, be verified under worst-case operating conditions.

The capacitor combinations listed in Table 1 are suitable for output currents up to 220mA and 300mA . Smaller capacitors may be considered for applications requiring less than 300mA output current. Smaller solution size can be achieved at the cost of increased input and output voltage ripple and decreased output current capability.

C_{IN} , C_{FLY} and C_{OUT} should be located close to the AAT3183 device in order to minimize stray parasitics; specifically ESR and ESL due to PCB layout traces. See the “PCB Layout Guidelines” section of this datasheet for details.

The input capacitor (C_{IN}) is required to maintain low input voltage ripple as well as minimize noise coupling to nearby circuitry. The size of the required input capacitor can vary, and depends on the source impedance of the input voltage source. A small $1\mu\text{F}$ to $2.2\mu\text{F}$ MLC input capacitor is suitable in most applications. MLC capacitors sized as small as 0402 are available which meet these requirements.

The flying capacitor (C_{FLY}) transfers energy to the output during both 'charge' and 'discharge' intervals. C_{FLY} is sized to maintain the maximum output load and maintain acceptable output voltage ripple at the minimum input voltage.

The ratio C_{OUT} to C_{FLY} is determined by the input to output voltage ratio and should be maintained near 5:1 for best performance across the operating range.

Input Capacitor		Output Capacitor		Input [$1\mu\text{F}(\text{min})$] and Flying Capacitors		Maximum Output Current I_{OUT} (mA)
Size	C_{IN} ($\mu\text{F}/\text{V}$)	Size	C_{OUT} ($\mu\text{F}/\text{V}$)	Size	C_{FLY} ($\mu\text{F}/\text{V}$)	
0402	2.2/6.3	0603	2.2/6.3	0402	0.47/10	220
0603	4.7/6.3	0603	4.7/6.3	0402	1/10	300

Table 1: AAT3183 Capacitor Size Selection Chart
(see Table 2 for corresponding manufacturer part numbers).

Input and Output Capacitors				Input [$1\mu\text{F}(\text{min})$] and Flying Capacitors			
C_{IN}/C_{OUT} Value	Voltage (size)	Mfg	Part Number	C_{FLY} Value	Voltage (size)	Mfg	Part Number
2.2 μF	16V (0603)	TDK	C1608X5R1C225K	0.47 μF	10V (0402)	TDK	C1005X5R1A474K
4.7 μF	10V (0603)	TDK	C1608X5R1A475K	1 μF	10V (0402)	TDK	C1005X5R1A105K
2.2 μF	16V (0603)	Murata	GRM188R61C225K	0.47 μF	10V (0402)	Murata	GRM155R61A474K
4.7 μF	6.3V (0603)	Murata	GRM188R60J475K	1 μF	10V (0402)	Murata	GRM155R61A105K
2.2 μF	16V (0603)	Taiyo-Yuden	EMK107BJ225KA	0.47 μF	10V (0402)	Taiyo-Yuden	LMK105BJ474KV
4.7 μF	10V (0603)	Taiyo-Yuden	LMK107BJ475KA	1 μF	16V (0603)	Taiyo-Yuden	EMK107BJ105KA

Table 2: Ceramic Capacitors for the 300mA AAT3183 Step-Down Charge Pump Converter.

Input and Output Voltage Ripple: Charge Pump Operation

The AAT3183 minimizes switching noise with PFM control. PFM switches only when required to maintain the output load, reducing the total switching noise. PFM control generates a small amount of V_{IN} and V_{OUT} regulation ripple (ΔV_{PFM}) due to the charge and discharge of the input and output capacitors. Additional voltage ripple is due to the parasitic resistance and inductance distributed on circuit traces and within the input, fly, and output capacitors themselves; see Figure 3 for the graphic illustration of the AC parasitic components of a AAT3183 typical application circuit.

During the charge pump switching events, an AC current path (I_{AC}) is established from the voltage source (V_{IN}) and input capacitor (C_{IN}) through the flying capacitor (C_{FLY}) to the output capacitor (C_{OUT}) and returning through the ground plane (GND).

The AC voltage ripple signal is measured across C_{IN} and C_{OUT} and is highest at full load and high V_{IN} . These AC currents charge and discharge the flying capacitor and flow through the ESR and ESL, which are parasitic elements within the capacitors. Circuit board traces can add to ESR and ESL and will contribute to the AC voltage ripple. Proper component

selection and good layout practice are critical in providing low ripple, low EMI performance. These parasitic elements should be minimized to optimize loop transient response and achieve stable operation.

The I_{AC} current from the flying capacitor flows through parasitic ESR and ESL. Voltage ripple across the input and output capacitors due to ESR and ESL are approximated:

$$\Delta V_{ESR} = ESR_{TOT} \cdot I_{AC}$$

$$\Delta V_{ESL} = \frac{(ESL_{TOT} \cdot I_{AC})}{\Delta t_{RISE-FALL}}$$

The total AC voltage ripple (V_{RIPPLE}) is the sum of the individual AC voltage ripple signals.

$$V_{RIPPLE} = \Delta V_{ESR} + \Delta V_{ESL} + \Delta V_{PFM}$$

Due to fast switching, a large amount of AC switching noise due to the parasitic ESL within the C_{IN} and C_{OUT} ceramic capacitors is seen on the output ripple. This noise may be attenuated with a small amount of input and output filtering.

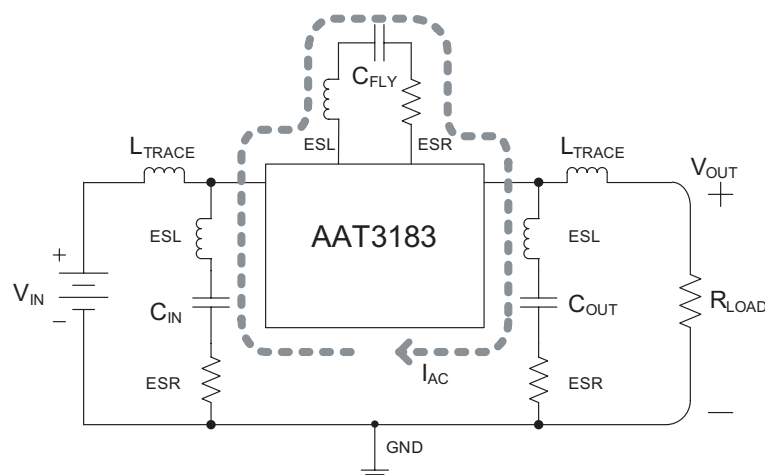

Figure 3: AC Parasitic Components of an AAT3183 Typical Application Circuit.

Thermal Performance

Power de-rating of the AAT3183 is not necessary in most cases due to the low thermal resistance of the SC70JW-8 package, and the limited device losses. Under operating conditions $V_{OUT} = 1.5V$ and $I_{OUT} = 300mA$, the estimated worst-case operating efficiency (η) is 68% ($V_{IN} = 4.2V$).

$$\begin{aligned}\eta &= \frac{P_{OUT}}{P_{IN}} \\ &= \frac{(V_{OUT} \cdot I_{OUT})}{(V_{IN} \cdot I_{IN})}\end{aligned}$$

Device power dissipation (P_D) can be estimated:

$$\begin{aligned}P_D &= P_{IN} - P_{OUT} \\ &= \frac{P_{OUT}}{\eta} - P_{OUT} \\ &= V_{OUT} \cdot I_{OUT} \cdot \frac{(1 - \eta)}{\eta} \\ &= 1.5V \cdot 0.3A \cdot \frac{(1 - 0.68)}{0.68} \\ &= 211.8mW\end{aligned}$$

The typical junction-to-ambient thermal resistance ($R_{\theta JA}$) of a SC70JW-8 package mounted on an FR4 board is $160^\circ C/W$. The maximum junction temperature ($T_{J(MAX)}$) of the device at $85^\circ C$ ambient is estimated: This is below the maximum recommended device junction temperature of $125^\circ C$.

$$\begin{aligned}T_{J(MAX)} &= T_{AMB(MAX)} + (P_D \cdot R_{\theta JA}) \\ &= 85^\circ C + (211.8mW \cdot 160^\circ C/W) \\ &= 119^\circ C\end{aligned}$$

PCB Layout Guidelines

Proper circuit board layout will maximize efficiency while minimizing switching noise and EMI. The following guidelines should be observed when designing the printed circuit board layout for the AAT3183 step-down converter:

1. Place the three external capacitors as close to the AAT3183 device as possible. Maintain the circuit board traces as short and wide as possible. This will minimize noise resulting from parasitic ESR and ESL in the AC current path.
2. Maintain short and wide traces from ground plane to circuit nodes. This will minimize stray parasitics.
3. A good example of an optimal layout for the AAT3183 is the AAT3183 evaluation board shown in Figures 4 and 5. The evaluation board schematic is shown in Figure 6.

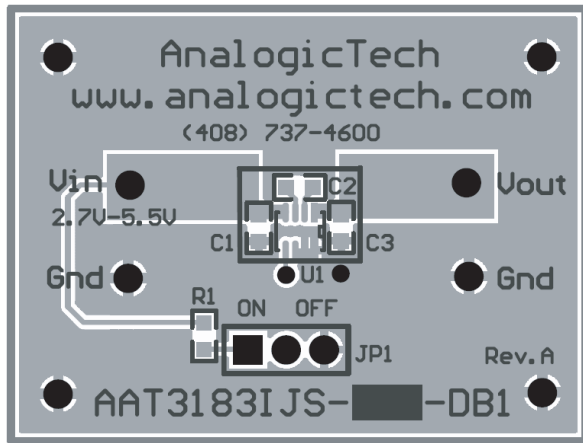

Figure 4: AAT3183 Evaluation Board Top Layer.

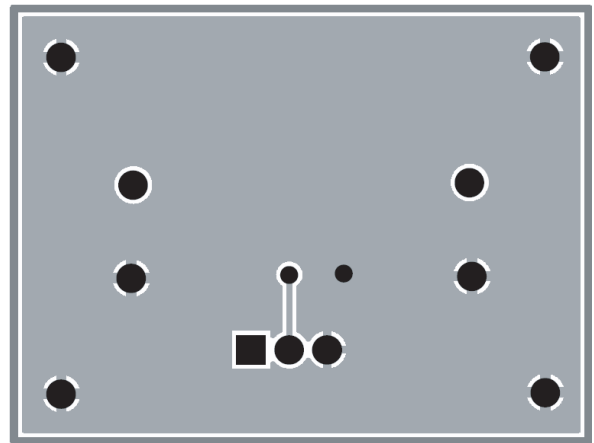

Figure 5: AAT3183 Evaluation Board Bottom Layer.

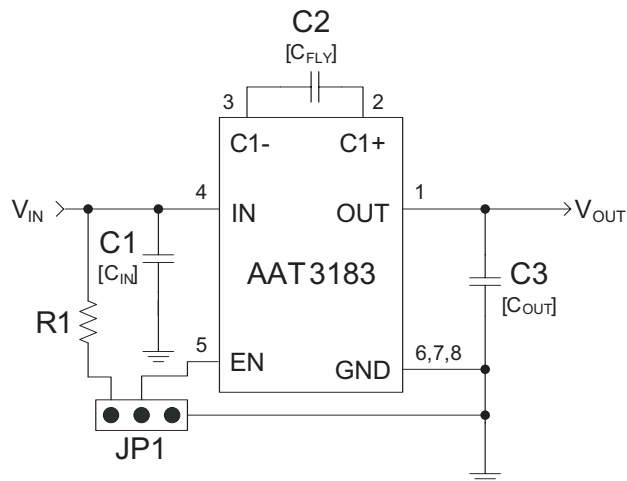

Figure 6: AAT3183 Evaluation Board Schematic.

Ordering Information

Output Voltage	Package	Marking ¹	Part Number (Tape and Reel) ²
1.5V	SC70JW-8	UJXY	AAT3183IJS-1.5-T1



All AnalogicTech products are offered in Pb-free packaging. The term “Pb-free” means semiconductor products that are in compliance with current RoHS standards, including the requirement that lead not exceed 0.1% by weight in homogeneous materials. For more information, please visit our website at <http://www.analogictech.com/pbfree>.

Packaging Information

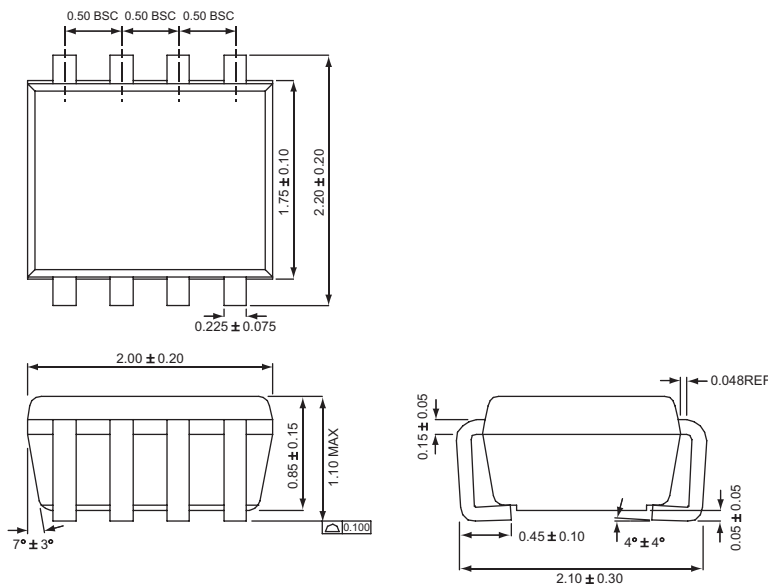

All dimensions in millimeters.

1. XYY = assembly and date code.
2. Sample stock is generally held on part numbers listed in **BOLD**.

© Advanced Analogic Technologies, Inc.

AnalogicTech cannot assume responsibility for use of any circuitry other than circuitry entirely embodied in an AnalogicTech product. No circuit patent licenses, copyrights, mask work rights, or other intellectual property rights are implied. AnalogicTech reserves the right to make changes to their products or specifications or to discontinue any product or service without notice. Except as provided in AnalogicTech's terms and conditions of sale, AnalogicTech assumes no liability whatsoever, and AnalogicTech disclaims any express or implied warranty relating to the sale and/or use of AnalogicTech products including liability or warranties relating to fitness for a particular purpose, merchantability, or infringement of any patent, copyright or other intellectual property right. In order to minimize risks associated with the customer's applications, adequate design and operating safeguards must be provided by the customer to minimize inherent or procedural hazards. Testing and other quality control techniques are utilized to the extent AnalogicTech deems necessary to support this warranty. Specific testing of all parameters of each device is not necessarily performed. AnalogicTech and the AnalogicTech logo are trademarks of Advanced Analogic Technologies Incorporated. All other brand and product names appearing in this document are registered trademarks or trademarks of their respective holders.

Advanced Analogic Technologies, Inc.
 830 E. Arques Avenue, Sunnyvale, CA 94085
 Phone (408) 737-4600
 Fax (408) 737-4611