

Input rectifier bridge +
Brake + 3 Phase Bridge
NPT IGBT Power Module

$V_{CES} = 600V$
 $I_C = 15A @ T_c = 80^\circ C$

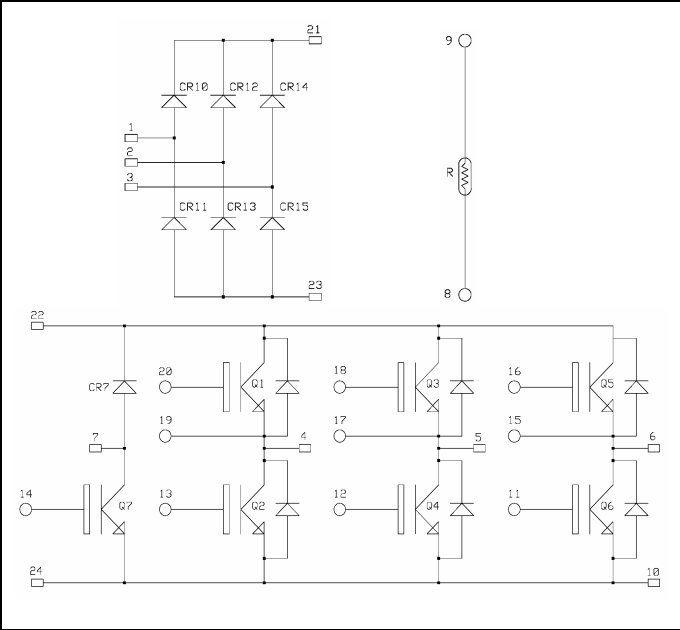

APTGF15X60RTP2: Without Brake (Pin 7 & 14 not connected)

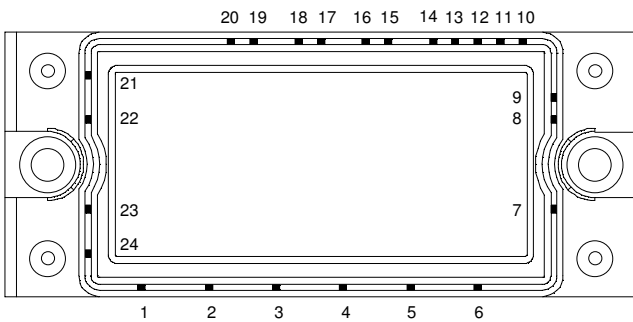

Application

- AC Motor control

Features

- Non Punch Through (NPT) Fast IGBT®
 - Low voltage drop
 - Low tail current
 - Switching frequency up to 50 kHz
 - Soft recovery parallel diodes
 - Low diode VF
 - Low leakage current
 - Avalanche energy rated
 - RBSOA and SCSOA rated
- Very low stray inductance
- High level of integration
- Internal thermistor for temperature monitoring

Benefits

- Low conduction losses
- Stable temperature behavior
- Very rugged
- Solderable terminals for easy PCB mounting
- Direct mounting to heatsink (isolated package)
- Low junction to case thermal resistance
- Easy paralleling due to positive TC of VCEsat
- Low profile

All ratings @ $T_j = 25^\circ C$ unless otherwise specified

1. Absolute maximum ratings

Diode rectifier Absolute maximum ratings

Symbol	Parameter	Max ratings	Unit
V_{RRM}	Repetitive Peak Reverse Voltage	1600	V
I_D	DC Forward Current	$T_c = 80^\circ C$ 15	A
I_{FSM}	Surge Forward Current	$T_j = 25^\circ C$ 300	
		$T_j = 150^\circ C$ 230	
	$t_p = 10ms$		

 **CAUTION:** These Devices are sensitive to Electrostatic Discharge. Proper Handling Procedures Should Be Followed.

IGBT & Diode Brake (only for APTGF15X60BTP2) Absolute maximum ratings

Symbol	Parameter	Max ratings	Unit
V _{CES}	Collector - Emitter Breakdown Voltage	600	V
I _C	Continuous Collector Current	T _C = 25°C	20
		T _C = 80°C	10
I _{CM}	Pulsed Collector Current	T _C = 25°C	25
V _{GE}	Gate – Emitter Voltage	±20	V
P _D	Maximum Power Dissipation	T _C = 25°C	80
I _F	DC Forward Current	T _C = 80°C	10

IGBT & Diode Inverter Absolute maximum ratings

Symbol	Parameter	Max ratings	Unit
V _{CES}	Collector - Emitter Breakdown Voltage	600	V
I _C	Continuous Collector Current	T _C = 25°C	25
		T _C = 80°C	15
I _{CM}	Pulsed Collector Current	T _C = 25°C	37
V _{GE}	Gate – Emitter Voltage	±20	V
P _D	Maximum Power Dissipation	T _C = 25°C	100
SCSOA	Short circuit Safe Operating Area	T _j = 125°C	65A @ 360V
I _F	DC Forward Current	T _C = 80°C	15
I _{FSM}	Surge Forward Current	t _p = 1ms T _C = 80°C	30

2. Electrical Characteristics

Diodes Rectifier Electrical Characteristics

Symbol	Characteristic	Test Conditions	Min	Typ	Max	Unit
I _R	Reverse Current	V _R = 1600V T _j = 150°C		2		mA
V _F	Forward Voltage	I _F = 30A T _j = 25°C		1.3	1.5	V
		I _F = 15A T _j = 150°C		0.95	1	
R _{thJC}	Junction to Case				1	°C/W

IGBT Brake & Diode (only for APTGF15X60BTP2) Electrical Characteristics

Symbol	Characteristic	Test Conditions	Min	Typ	Max	Unit
I _{CES}	Zero Gate Voltage Collector Current	V _{GE} = 0V V _{CE} = 600V	T _j = 25°C	0.5	500	µA
			T _j = 125°C	0.8		mA
V _{CE(on)}	Collector Emitter on Voltage	V _{GE} = 15V I _C = 10A	T _j = 25°C	1.95	2.35	V
			T _j = 125°C	2.2		
V _{GE(th)}	Gate Threshold Voltage	V _{GE} = V _{CE} , I _C = 0.35 mA	4.5	5.5	6.5	V
I _{GES}	Gate – Emitter Leakage Current	V _{GE} = 20V, V _{CE} = 0V			300	nA
C _{ies}	Input Capacitance	V _{GE} = 0V, V _{CE} = 25V f = 1MHz		600		pF
V _F	Forward Voltage	V _{GE} = 0V I _F = 15A	T _j = 25°C	1.25	1.70	V
			T _j = 125°C	1.2		
R _{thJC}	Junction to Case		IGBT		1.5	°C/W
			Diode		1.8	

IGBT & Diode Inverter Electrical Characteristics

Symbol	Characteristic	Test Conditions	Min	Typ	Max	Unit
BV _{CES}	Collector - Emitter Breakdown Voltage	V _{GE} = 0V, I _C = 500μA	600			V
I _{CES}	Zero Gate Voltage Collector Current	V _{GE} = 0V V _{CE} = 600V	T _j = 25°C	0.5	500	μA
			T _j = 125°C	0.8		mA
V _{CE(on)}	Collector Emitter on Voltage	V _{GE} = 15V I _C = 15A	T _j = 25°C	1.95	2.45	V
			T _j = 125°C	2.2		
V _{GE(th)}	Gate Threshold Voltage	V _{GE} = V _{CE} , I _C = 0.4 mA	4.5	5.5	6.5	V
I _{GES}	Gate – Emitter Leakage Current	V _{GE} = 20V, V _{CE} = 0V			300	nA
C _{ies}	Input Capacitance	V _{GE} = 0V, V _{CE} = 25V f = 1MHz		800		pF
T _{d(on)}	Turn-on Delay Time	Inductive Switching (25°C) V _{GE} = ±15V V _{Bus} = 300V I _C = 15A R _G = 67Ω		50		ns
T _r	Rise Time			50		
T _{d(off)}	Turn-off Delay Time			250		
T _f	Fall Time			30		
T _{d(on)}	Turn-on Delay Time	Inductive Switching (125°C) V _{GE} = ±15V V _{Bus} = 300V I _C = 15A R _G = 67Ω		50		ns
T _r	Rise Time			50		
T _{d(off)}	Turn-off Delay Time			270		
T _f	Fall Time			40		
E _{off}	Turn off Energy			0.5		
V _F	Forward Voltage	V _{GE} = 0V I _F = 15A	T _j = 25°C	1.25	1.7	V
			T _j = 125°C	1.2		
Q _{rr}	Reverse Recovery Charge	I _F = 15A V _R = 300V di/dt=550A/μs	T _j = 25°C	1.2		μC
			T _j = 125°C	2		
R _{thJC}	Junction to Case		IGBT		1.3	°C/W
			Diode		1.8	

Temperature sensor NTC

Symbol	Characteristic	Min	Typ	Max	Unit
R ₂₅	Resistance @ 25°C		5		kΩ
B _{25/50}	T ₂₅ = 298.16 K		3375		K

$$R_T = \frac{R_{25}}{\exp \left[B_{25/50} \left(\frac{1}{T_{25}} - \frac{1}{T} \right) \right]}$$

T: Thermistor temperature
R_T: Thermistor value at T

3. Thermal and package characteristics

Symbol	Characteristic	Min	Typ	Max	Unit
V _{ISOL}	RMS Isolation Voltage, any terminal to case t=1 min, I _{isol} <1mA, 50/60Hz	2500			V
T _J	Operating junction temperature range	-40		150	°C
T _{STG}	Storage Temperature Range	-40		125	
T _C	Operating Case Temperature	-40		125	
Torque	Mounting torque	To Heatsink	M5		3.3 N.m
Wt	Package Weight			185	g

4. Package outline

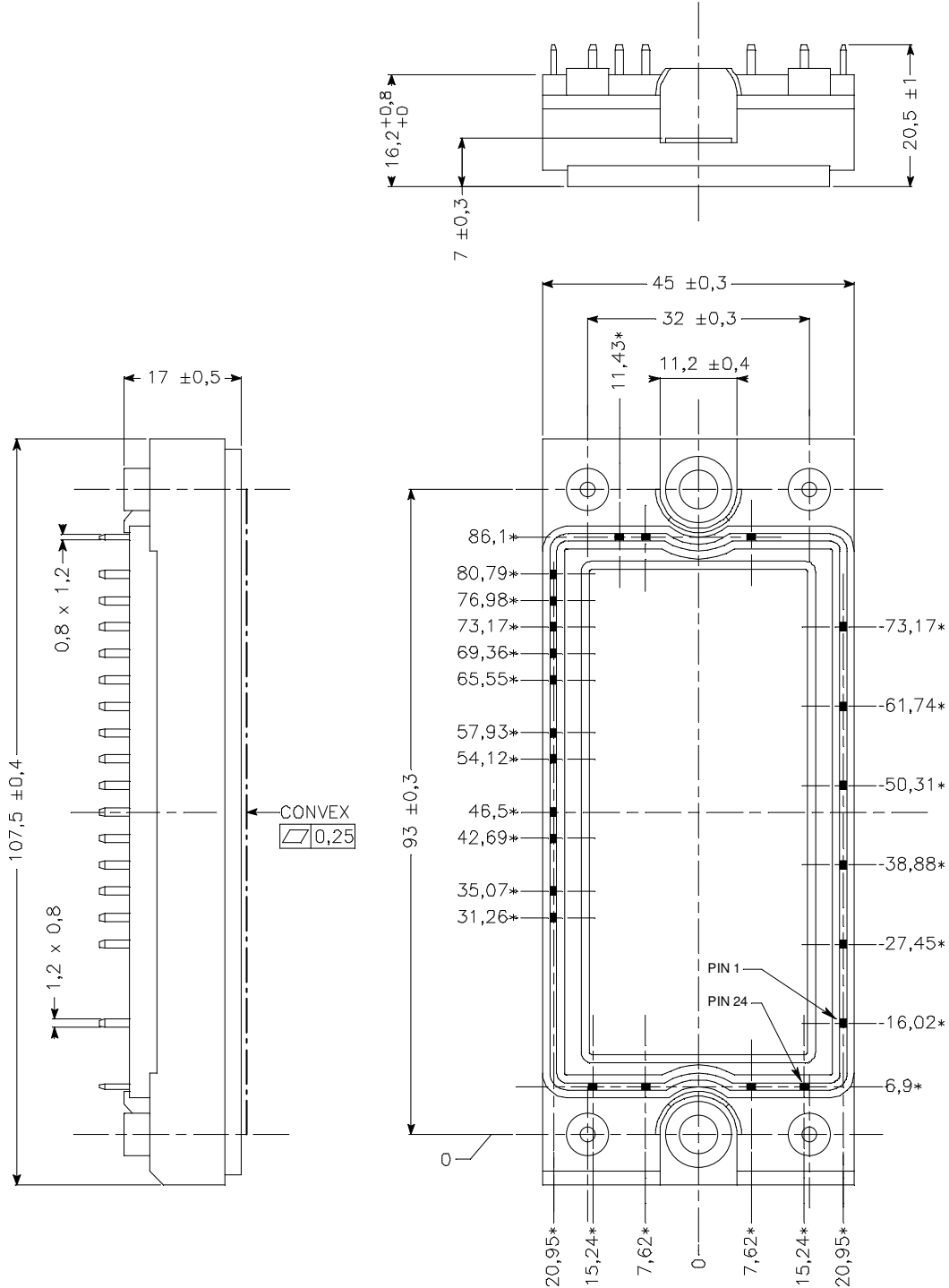

ALL DIMENSIONS MARKED "*" ARE TOLERENCED AS: $\oplus \ominus \varnothing 0,4$

APT reserves the right to change, without notice, the specifications and information contained herein

APT's products are covered by one or more of U.S. patents 4,895,810 5,045,903 5,089,434 5,182,234 5,019,522 5,262,336 6,503,786 5,256,583 4,748,103 5,283,202 5,231,474 5,434,095 5,528,058 and foreign patents. U.S and Foreign patents pending. All Rights Reserved.