

STRUCTURE	Silicon monolithic integrated circuits
PRODUCT SERIES	3-phase motor driver for VTR capstan
TYPE	<b>BA6878EFV</b>
FUNCTION	<ul style="list-style-type: none"> <li>▪ 180°, 3-phase full-wave pseudo-linear drive system</li> <li>▪ Built-in current limit and thermal shut down circuits</li> </ul>

○Absolute maximum ratings (Ta=25°C)

Parameter	Symbol	Limit	Unit
Supply voltage	VCC	7	V
	VM	23	V
Power dissipation	Pd	1.1 <sup>※1</sup>	W
Input voltage	VIN	0~VCC	V
Maximum output current	IOUT	1500 <sup>※2</sup>	mA
Operating temperature range	Topr	-25~+75	°C
Storage temperature range	Tstg	-55~+150	°C
Junction temperature	Tjmax	150	°C

※1 70mm × 70mm × 1.6mm glass epoxy board. Derating is done at 8.8mW/°C for operating above Ta=25°C.

※2 Do not, however exceed Pd, ASO and Tjmax=150°C.

○Recommended operating conditions (Ta= -25~+75°C)

Parameter	Symbol	Min	Typ	Max	Unit
Supply voltage	VCC	4.5	5.0	5.5	V
	VM	4.5	12	22.0	V
Hall amp in-phase input voltage range	VCH	1.5	-	VCC-1.5	V

This product described in this specification isn't judged whether it applies to COCOM regulations.

Please confirm in case of export.

This product isn't designed for protection against radioactive rays.

○Electrical characteristics (Unless otherwise specified, Ta=25°C, VCC=5V, VM=12V)

Parameter	Symbol	Limit			Unit	Conditions
		Min	Typ	Max		
<b>CAP Drv</b>						
Circuit current	Icc	-	7.4	11.0	mA	Ec=GND, input LLH
Hall input conversion offset	Heofs	-6	0	6	mV	
Torque reference start voltage	ECst	2.35	2.50	2.65	V	
Output idling voltage	ECidle	-	0	10	mV	EC=GND
Torque reference input gain	Gio	0.64	0.77	0.90	A/V	
Forward rotation reference voltage range	VEDF	-	-	2.2	V	
Reverse rotation reference voltage range	VEDR	2.8	-	-	V	
Torque limit current	ITL	0.89	1.00	1.11	A	RNF=0.5Ω
High output voltage	VOH	1.20	1.55	1.90	V	IOUT=-0.8A
Low output voltage 1	VOL	1.10	1.55	2.00	V	IOUT=0.8A, RNF=0.5Ω, EC<4.5V
Low output voltage 2	VOL2	1.05	1.50	1.95	V	IOUT=0.8A, RNF=0.5Ω, EC=Vcc
Low-side saturation prevention off voltage	Voff	4.5	4.7	4.9	V	
<b>FG Amp</b>						
FGin- input current	IFGin-	-21	-43	-65	μA	
FG Amp Gain1	GFG1	26	33	-	dB	f=500Hz
FG Amp Gain2	GFG2	26	33	-	dB	f=30KHz
DC bias voltage	VBFG	2.4	2.5	2.6	V	
High FG output voltage	VFGH	-	0.3	0.6	V	IFG=-0.2mA, VFGH=Vcc-FGout
Low FG output voltage	VFGL	-	0.2	0.5	V	IFG=1mA
<b>Hys Amp</b>						
Hysteresis width	Vhys	32	46	60	mV	
Low hysteresis output voltage	VhysL	-	0.17	0.39	V	Ihys=1mA
Output pull-up resistance	Rhys	15	20	25	kΩ	

OPackage outline

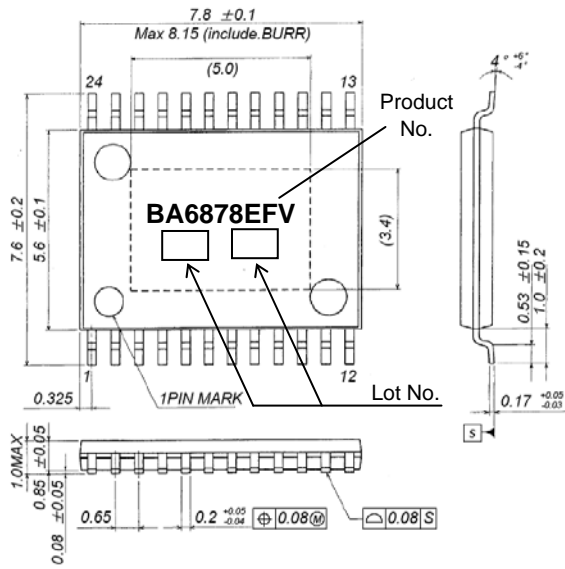

HTSSOP-B24 (Unit: mm)

OBlock diagram

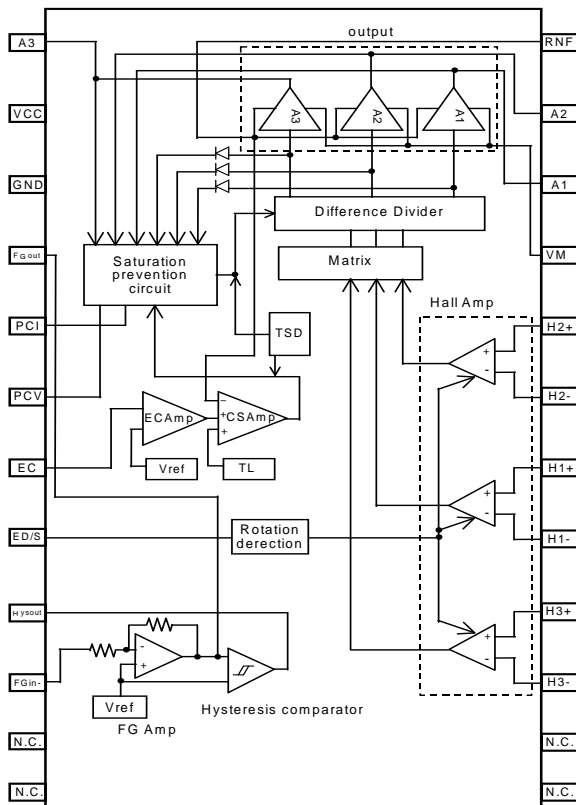

OPin No. / Pin name

Pin No.	Pin name
1	A3
2	Vcc
3	GND
4	FGout
5	PCI
6	PCV
7	EC
8	ED/S
9	Hysout
10	FGin-
11	N.C
12	N.C
13	N.C
14	N.C
15	H3-
16	H3+
17	H1-
18	H1+
19	H2-
20	H2+
21	VM
22	A1
23	A2
24	RNF

Operation Notes

(1) Absolute maximum ratings

Use of the IC in excess of absolute maximum ratings such as the applied voltage or operating temperature range (Topr) may result in IC damage. Assumptions should not be made regarding the state of the IC (short mode or open mode) when such damage is suffered. The implementation of a physical safety measure such as a fuse should be considered when use of the IC in a special mode where the absolute maximum ratings may be exceeded is anticipated.

(2) Power supply lines

Regenerated current may flow as a result of the motor's back electromotive force. Insert capacitors between the power supply and ground pins to serve as a route for regenerated current. Determine the capacitance in full consideration of all the characteristics of the electrolytic capacitor, because the electrolytic capacitor may lose some capacitance at low temperatures. If the connected power supply does not have sufficient current absorption capacity, regenerative current will cause the voltage on the power supply line to rise, which combined with the product and its peripheral circuitry may exceed the absolute maximum ratings. It is recommended to implement a physical safety measure such as the insertion of a voltage clamp diode between the power supply and GND pins.

(3) Ground potential

Ensure a minimum GND pin potential in all operating conditions.

(4) Setting of heat

Use a thermal design that allows for a sufficient margin in light of the power dissipation (Pd) in actual operating conditions. This IC exposes its frame of the backside of package. Note that this part is assumed to use after providing heat dissipation treatment to improve heat dissipation efficiency. Try to occupy as wide as possible with heat dissipation pattern not only on the board surface but also the backside.

(5) Actions in strong magnetic field

Use caution when using the IC in the presence of a strong magnetic field as doing so may cause the IC to malfunction.

(6) ASO

When using the IC, set the output transistor for the motor so that it does not exceed absolute maximum ratings or ASO.

(7) Thermal shutdown circuit

This IC incorporates a TSD (thermal shutdown) circuit (TSD circuit). If the temperature of the chip reaches the following temperature, the motor coil output will be opened. The thermal shutdown circuit (TSD circuit) is designed only to shut the IC off to prevent runaway thermal operation. It is not designed to protect the IC or guarantee its operation. Do not continue to use the IC after operating this circuit or use the IC in an environment where the operation of this circuit is assumed.

TSD on temperature [°C] (typ.)	Hysteresis temperature [°C] (typ.)
175	25

(8) Ground Wiring Pattern

When using both small signal and large current GND patterns, it is recommended to isolate the two ground patterns, placing a single ground point at the application's reference point so that the pattern wiring resistance and voltage variations caused by large currents do not cause variations in the small signal ground voltage. Be careful not to change the GND wiring pattern of any external components, either.

## Notes

No copying or reproduction of this document, in part or in whole, is permitted without the consent of ROHM Co.,Ltd.

The content specified herein is subject to change for improvement without notice.

The content specified herein is for the purpose of introducing ROHM's products (hereinafter "Products"). If you wish to use any such Product, please be sure to refer to the specifications, which can be obtained from ROHM upon request.

Examples of application circuits, circuit constants and any other information contained herein illustrate the standard usage and operations of the Products. The peripheral conditions must be taken into account when designing circuits for mass production.

Great care was taken in ensuring the accuracy of the information specified in this document. However, should you incur any damage arising from any inaccuracy or misprint of such information, ROHM shall bear no responsibility for such damage.

The technical information specified herein is intended only to show the typical functions of and examples of application circuits for the Products. ROHM does not grant you, explicitly or implicitly, any license to use or exercise intellectual property or other rights held by ROHM and other parties. ROHM shall bear no responsibility whatsoever for any dispute arising from the use of such technical information.

The Products specified in this document are intended to be used with general-use electronic equipment or devices (such as audio visual equipment, office-automation equipment, communication devices, electronic appliances and amusement devices).

The Products specified in this document are not designed to be radiation tolerant.

While ROHM always makes efforts to enhance the quality and reliability of its Products, a Product may fail or malfunction for a variety of reasons.

Please be sure to implement in your equipment using the Products safety measures to guard against the possibility of physical injury, fire or any other damage caused in the event of the failure of any Product, such as derating, redundancy, fire control and fail-safe designs. ROHM shall bear no responsibility whatsoever for your use of any Product outside of the prescribed scope or not in accordance with the instruction manual.

The Products are not designed or manufactured to be used with any equipment, device or system which requires an extremely high level of reliability the failure or malfunction of which may result in a direct threat to human life or create a risk of human injury (such as a medical instrument, transportation equipment, aerospace machinery, nuclear-reactor controller, fuel-controller or other safety device). ROHM shall bear no responsibility in any way for use of any of the Products for the above special purposes. If a Product is intended to be used for any such special purpose, please contact a ROHM sales representative before purchasing.

If you intend to export or ship overseas any Product or technology specified herein that may be controlled under the Foreign Exchange and the Foreign Trade Law, you will be required to obtain a license or permit under the Law.



Thank you for your accessing to ROHM product informations.  
More detail product informations and catalogs are available, please contact us.

### ROHM Customer Support System

<http://www.rohm.com/contact/>