

40V 3.0A QUAD POWER HALF BRIDGE

PRODUCT PREVIEW

1 FEATURES

- MULTIPOWER BCD TECHNOLOGY
- MINIMUM INPUT OUTPUT PULSE WIDTH DISTORTION
- 200mΩ R_{dsON} COMPLEMENTARY DMOS OUTPUT STAGE
- CMOS COMPATIBLE LOGIC INPUTS
- THERMAL PROTECTION
- THERMAL WARNING OUTPUT
- UNDER VOLTAGE PROTECTION
- SHORT CIRCUIT PROTECTION

2 DESCRIPTION

STA515 is a monolithic quad half bridge stage in Multipower BCD Technology. The device can be used also as dual bridge or reconfigured, by connecting CONFIG pin to V_{dd} pin, as single bridge with double current capability.

Figure 1. Package



Table 1. Order Codes

Part Number	Package
STA515	PSSO36 (slug up)

The device is particularly designed to make the output stage of a stereo All-Digital High Efficiency (DDX™) amplifier capable to deliver an output power of 20W x 4 channels @ THD = 10% at V_{CC} 26V on 4Ω load in single ended configuration.

It can also deliver 40 + 40W @ THD = 10% at V_{CC} 26V as output power on 8Ω load in BTL configuration and 60W @ THD = 10% at V_{CC} 32V on 8Ω in single parallel BTL configuration. The input pins have threshold proportional to V_L pin voltage.

Figure 2. AUDIO APPLICATION CIRCUIT (Quad single ended)

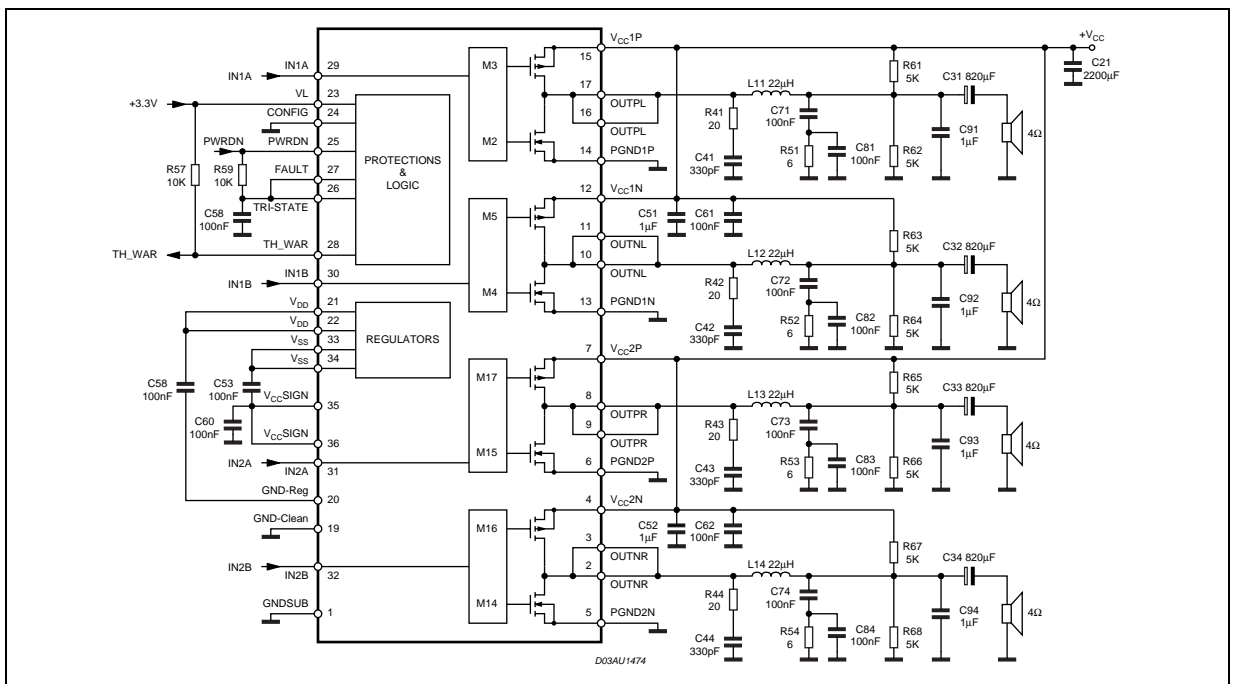

Table 2. PIN FUNCTION

N°	Pin	Description
1	GND-SUB	Substrate ground
2 ; 3	OUT2B	Output half bridge 2B
4	Vcc2B	Positive supply
5	GND2B	Negative Supply
6	GND2A	Negative Supply
7	Vcc2A	Positive supply
8 ; 9	OUT2A	Output half bridge 2A
10 ; 11	OUT1B	Output half bridge 1B
12	Vcc1B	Positive supply
13	GND1B	Negative Supply
14	GND1A	Negative Supply
15	Vcc1A	Positive supply
16 ; 17	OUT1A	Output half bridge 1A
18	NC	Not connected
19	GND-clean	Logical ground
20	GND-Reg	Ground for regulator Vdd
21 ; 22	Vdd	5V Regulator referred to ground
23	VL	Logic Reference Voltage
24	CONFIG	Configuration pin
25	PWRDN	Stand-by pin
26	TRI-STATE	Hi-Z pin
27	FAULT	Fault pin advisor
28	TH-WAR	Thermal warning advisor
29	IN1A	Input of half bridge 1A
30	IN1B	Input of half bridge 1B
31	IN2A	Input of half bridge 2A
32	IN2B	Input of half bridge 2B
33 ; 34	Vss	5V Regulator referred to +Vcc
35 ; 36	Vcc Sign	Signal Positive supply

Table 3. FUNCTIONAL PIN STATUS

www.DataSheet4U.com

PIN NAME	PIN N.	Logical value	IC -STATUS
FAULT	27	0	Fault detected (Short circuit, or Thermal ..)
FAULT *	27	1	Normal Operation
TRI-STATE	26	0	All powers in Hi-Z state
TRI-STATE	26	1	Normal operation
PWRDN	25	0	Low consumption
PWRDN	25	1	Normal operation
THWAR	28	0	Temperature of the IC =130C
THWAR ⁽¹⁾	28	1	Normal operation
CONFIG	24	0	Normal Operation
CONFIG ⁽²⁾	24	1	OUT1A=OUT1B ; OUT2A=OUT2B (IF IN1A = IN1B; IN2A = IN2B)

Note: 1. The pin is open collector. To have the high logic value, it needs to be pulled up by a resistor.
 2. To put CONFIG = 1 means connect Pin 24 (CONFIG) to Pins 21, 22 (Vdd) to implemented single BTL (MONO MODE) operation for high current.

Figure 3. PIN CONNECTION

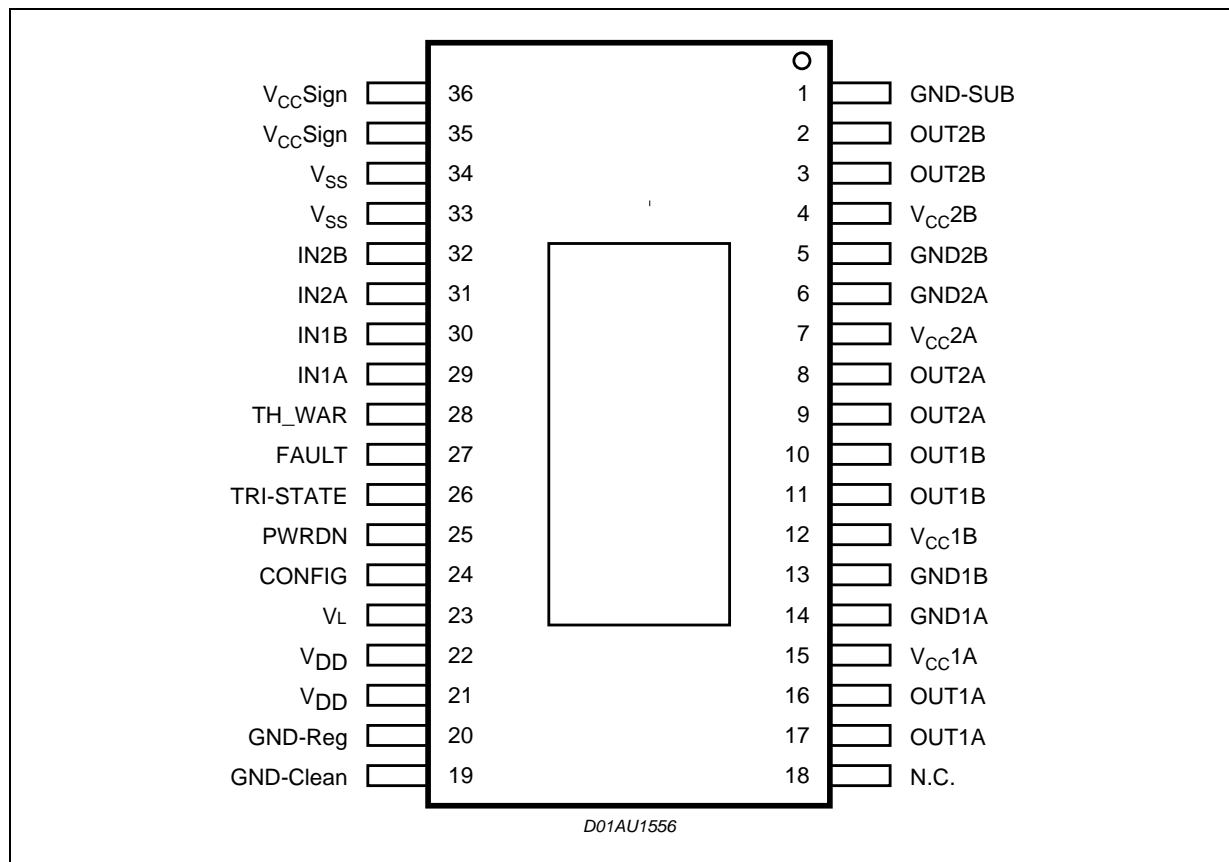

Table 4. ABSOLUTE MAXIMUM RATINGS

Symbol	Parameter	Value	Unit
V_{CE}	DC Supply Voltage (Pin 4,7,12,15)	40	V
V_{max}	Maximum Voltage on pins 23 to 32	5.5	V
T_{op}	Operating Temperature Range	0 to 70	°C
P_{tot}	Power Dissipation ($T_{case} = 70^{\circ}C$)	21	W
T_{stg}, T_j	Storage and Junction Temperature	-40 to 150	°C

Table 5. (*) RECOMMENDED OPERATING CONDITIONS

Symbol	Parameter	Min.	Typ.	Max.	Unit
V_{CC}	DC Supply Voltage	10		36.0	V
V_L	Input Logic Reference	2.7	3.3	5.0	v
T_{amb}	Ambient Temperature	0		70	°C

(*) performances not guaranteed beyond recommended operating conditions

Table 6. THERMAL DATA (*)

Symbol	Parameter	Min.	Typ.	Max.	Unit
T_{j-case}	Thermal Resistance Junction to Case (thermal pad)			1.5	°C/W
T_{jSD}	Thermal shut-down junction temperature		150		°C
T_{warn}	Thermal warning temperature		130		°C
t_{hSD}	Thermal shut-down hysteresis		25		°C

(*) see Thermal information

Table 7. ELECTRICAL CHARACTERISTICS refer to circuit in Fig.4 ($V_L = 3.3V$; $V_{CC} = 30V$; $R_L = 8\Omega$; $f_{sw} = 384KHz$; $T_{amb} = 25^{\circ}C$ unless otherwise specified)

Symbol	Parameter	Test conditions	Min.	Typ.	Max.	Unit
R_{dsON}	Power Pchannel/Nchannel MOSFET R_{dsON}	$I_d=1A; T=25^{\circ}C$		200	270	m Ω
I_{dss}	Power Pchannel/Nchannel leakage I_{dss}	$V_{cc}=35v; T=25^{\circ}C$			50	μA
g_N	Power Pchannel R_{dsON} Matching	$I_d=1A; T=25^{\circ}C$	95			%
g_P	Power Nchannel R_{dsON} Matching	$I_d=1A; T=25^{\circ}C$	95			%
Dt_s	Low current Dead Time (static)	see test circuit no.4; $T=25^{\circ}C$		10	20	ns
Dt_d	High current Dead Time (dynamic)	$L=22\mu H; C = 470nF; R_l = 8 \Omega$ $I_d=3.0A; T=25^{\circ}C$; see fig. 6			50	ns
t_{dON}	Turn-on delay time	Resistive load; $V_{cc}=30V; T=25^{\circ}C$			100	ns
t_{dOFF}	Turn-off delay time	Resistive load; $V_{cc}=30V; T=25^{\circ}C$			100	ns
t_r	Rise time	Resistive load; as fig.4; $T=25^{\circ}C$			25	ns
t_f	Fall time	Resistive load; as fig. 4; $T=25^{\circ}C$			25	ns
V_{CC}	Supply voltage operating voltage		10		36	V
V_{IN-H}	High level input voltage				$V_L/2 + 300mV$	V

TABLE 7. ELECTRICAL CHARACTERISTICS (continued)

www.DataSheet4U.com

Symbol	Parameter	Test conditions	Min.	Typ.	Max.	Unit
V_{IN-L}	Low level input voltage		$V_L/2 - 300mV$			V
I_{IN-H}	Hi level Input current	Pin voltage = V_L		1		μA
I_{IN-L}	Low level input current	Pin voltage = 0.3V		1		μA
$I_{PWRDN-H}$	Hi level PWRDN pin input current	$V_L = 3.3V$		35		μA
V_{LOW}	Low logical state voltage V_{Low} (pin PWRDN, TRISTATE) (note 1)	$V_L = 3.3V$	0.8			V
V_{HIGH}	High logical state voltage V_{High} (pin PWRDN, TRISTATE) (note 1)	$V_L = 3.3V$			1.7	V
$I_{VCC-PWRDN}$	Supply current from V_{cc} in Power Down	PWRDN = 0			3	mA
I_{FAULT}	Output Current pins FAULT -TH-WARN when FAULT CONDITIONS	$V_{pin} = 3.3V$		1		mA
$I_{VCC-hiz}$	Supply current from V_{cc} in Tri-state	$V_{cc}=30V$; Tri-state=0; $T=25^{\circ}C$		22		mA
I_{VCC}	Supply current from V_{cc} in operation (both channel switching)	$V_{cc}=30V$; Input pulse width = 50% Duty; Switching Frequency = 384Khz; No LC filters;		50		mA
I_{VCC-q}	I_{sc} (short circuit current limit) (note 2)	$V_{cc} = 30V$; $T = 25^{\circ}C$	3.0	6	8	A
I_{OUT-SH}	Undervoltage protection threshold	$T = 25^{\circ}C$		7		V
V_{OV}	Output minimum pulse width	No Load	70		150	ns

Notes: 1. The following table explains the V_{LOW} , V_{HIGH} variation with I_{bias}

V_L	$V_{Low\ min}$	$V_{High\ max}$	Unit
2.7	0.7	1.5	V
3.3	0.8	1.7	V
5	0.85	1.85	V

Note 2: See relevant Application Note AN1994

Table 8. LOGIC TRUTH TABLE (see fig. 5)

TRI-STATE	$INxA$	$INxB$	Q1	Q2	Q3	Q4	OUTPUT MODE
0	x	x	OFF	OFF	OFF	OFF	Hi-Z
1	0	0	OFF	OFF	ON	ON	DUMP
1	0	1	OFF	ON	ON	OFF	NEGATIVE
1	1	0	ON	OFF	OFF	ON	POSITIVE
1	1	1	ON	ON	OFF	OFF	Not used

Figure 4. Test Circuit.

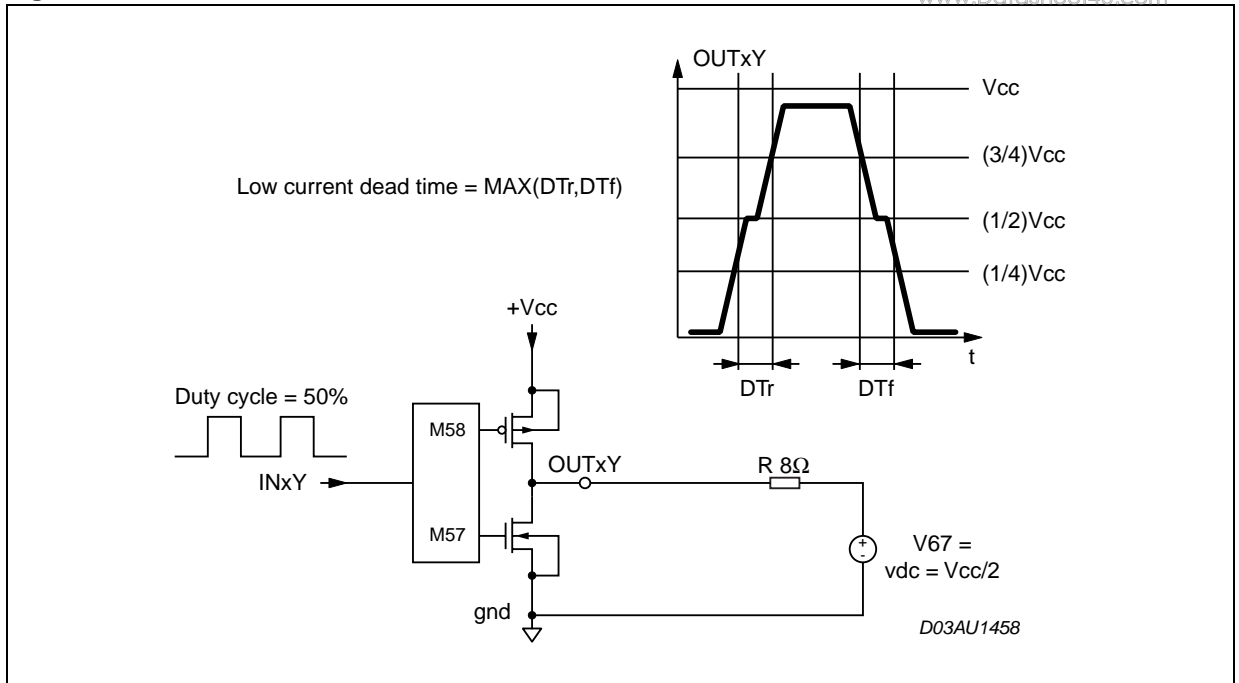

Figure 5.

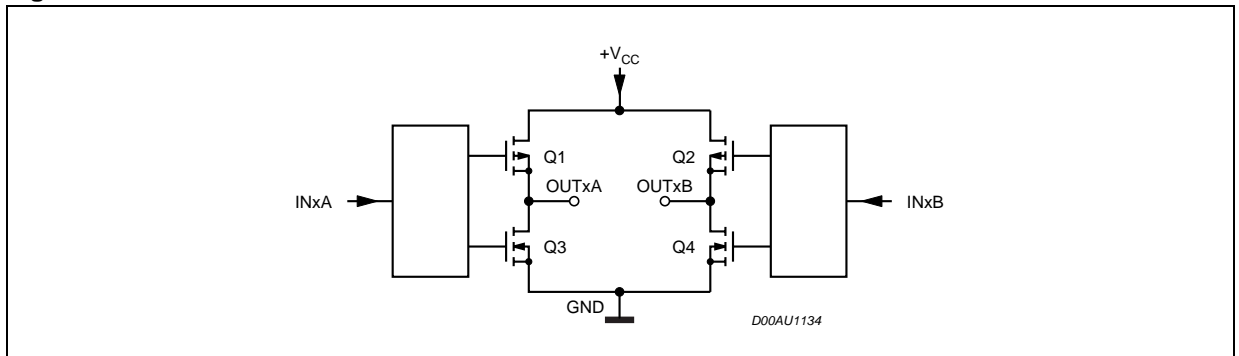
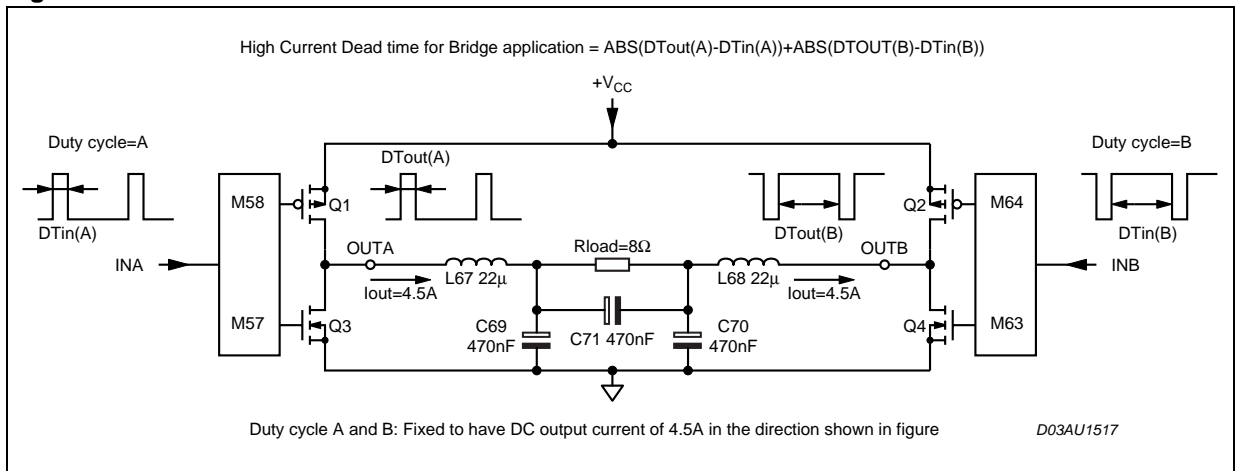

Figure 6.



3 TECHNICAL INFO:

www.DataSheet4U.com

The STA515 is a dual channel H-Bridge that is able to deliver 40W per channel (@ THD=10% $R_L = 8\Omega$, $V_{CC} = 26V$) of audio output power in high efficiency.

The STA515 converts both DDX and binary-controlled PWM signals into audio power at the load. It includes a logic interface, integrated bridge drivers, high efficiency MOSFET outputs and thermal and short circuit protection circuitry.

In DDX mode, two logic level signals per channel are used to control high-speed MOSFET switches to connect the speaker load to the input supply or to ground in a Bridge configuration, according to the damped ternary Modulation operation.

In Binary Mode operation, both Full Bridge and Half Bridge Modes are supported. The STA515 includes over-current and thermal protection as well as an under-voltage

Lockout with automatic recovery. A thermal warning status is also provided.

Figure 7. STA515 Block Diagram Full-Bridge DDX® or Binary Modes

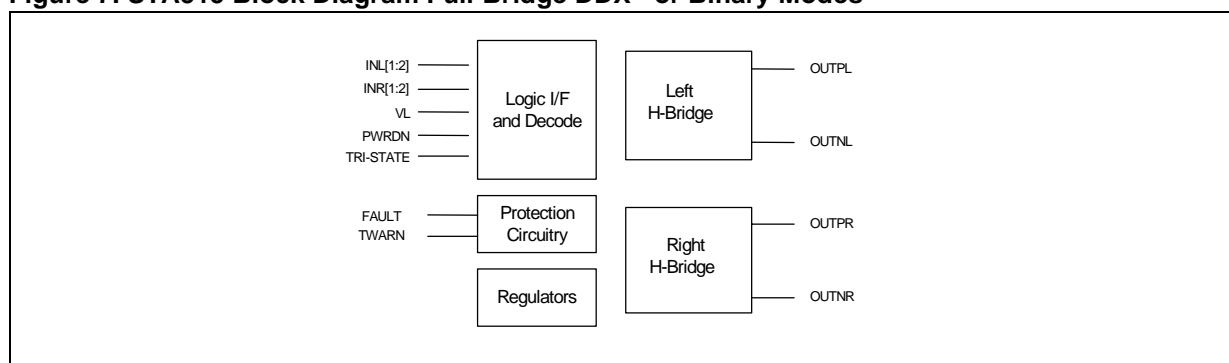
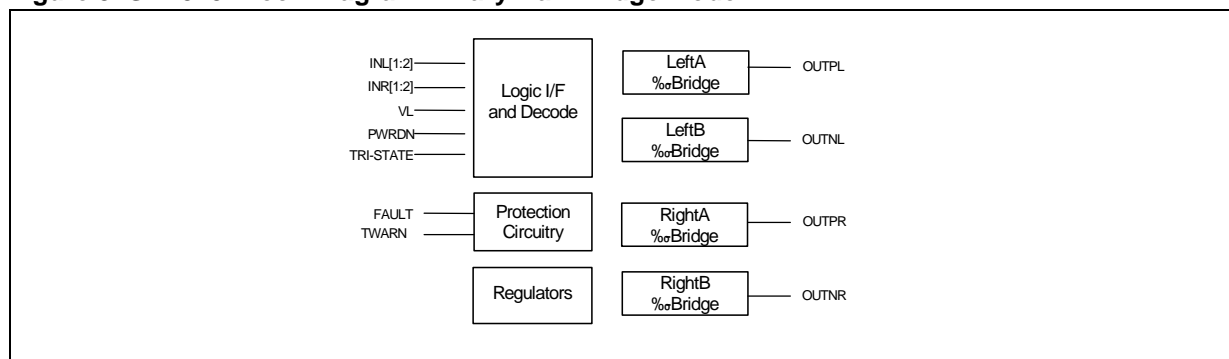

Figure 8. STA515 Block Diagram Binary Half-Bridge Mode



3.1 Logic Interface and Decode:

The STA515 power outputs are controlled using one or two logic level timing signals. In order to provide a proper logic interface, the Vbias input must operate at the same voltage as the DDX control logic supply.

3.2 Protection Circuitry:

The STA515 includes protection circuitry for over-current and thermal overload conditions. A thermal warning pin (pin.28) is activated low (open drain MOSFET) when the IC temperature exceeds 130C, in advance of the thermal shutdown protection. When a fault condition is detected, an internal fault signal acts to immediately disable the output power MOSFETs, placing both H-Bridges in high impedance state. At the same time an open-drain MOSFET connected to the fault pin (pin.27) is switched on.

There are two possible modes subsequent to activating a fault:

- **1) SHUTDOWN mode:** with FAULT (pull-up resistor) and TRI-STATE pins independent, an activated fault will disable the device, signaling low at the FAULT output.
The device may subsequently be reset to normal operation by toggling the TRI-STATE pin from High to Low to High using an external logic signal.

- **2) AUTOMATIC recovery mode:** This is shown in the Audio Application Circuit of Quad single Ended). The FAULT and TRI-STATE pins are shorted together and connected to a time constant circuit comprising R59 and C58.
An activated FAULT will force a reset on the TRI-STATE pin causing normal operation to resume following a delay determined by the time constant of the circuit.
If the fault condition is still present, the circuit operation will continue repeating until the fault condition is removed.
An increase in the time constant of the circuit will produce a longer recovery interval. Care must be taken in the overall system design as not to exceed the protection thresholds under normal operation.

3.3 Power Outputs:

The STA515 power and output pins are duplicated to provide a low impedance path for the device's bridged outputs.

All duplicate power, ground and output pins must be connected for proper operation.

The PWRDN or TRI-STATE pins should be used to set all MOSFETS to the Hi-Z state during power-up until the logic power supply, V_L , is settled.

3.4 Parallel Output / High Current Operation:

When using DDX Mode output, the STA515 outputs can be connected in parallel in order to increase the output current capability to a load.

In this configuration the STA515 can provide 60W into 8 ohm.

This mode of operation is enabled with the CONFIG pin (pin.24) connected to VREG1 and the inputs combined INLA=INLB, INRA=INRB and the outputs combined OUTLA=OTLB, OUTRA=OUTRB.

3.5 Additional Informations:

Output Filter: A passive 2nd-order passive filter is used on the STA515 power outputs to reconstruct an analog Audio Signal.

System performance can be significantly affected by the output filter design and choice of passive components. A filter design for 6ohm/8ohm loads is shown in the Typical Application circuit of fig.10.

Quad Single ended circuit (page 1) shows a filter for ½ bridge mode, 4 ohm loads.

Figure 9. Typical Stereo Full Bridge Configuration to obtain 40+40W @ THD = 10%, $R_L = 8\Omega$, $V_{CC} = 26V$

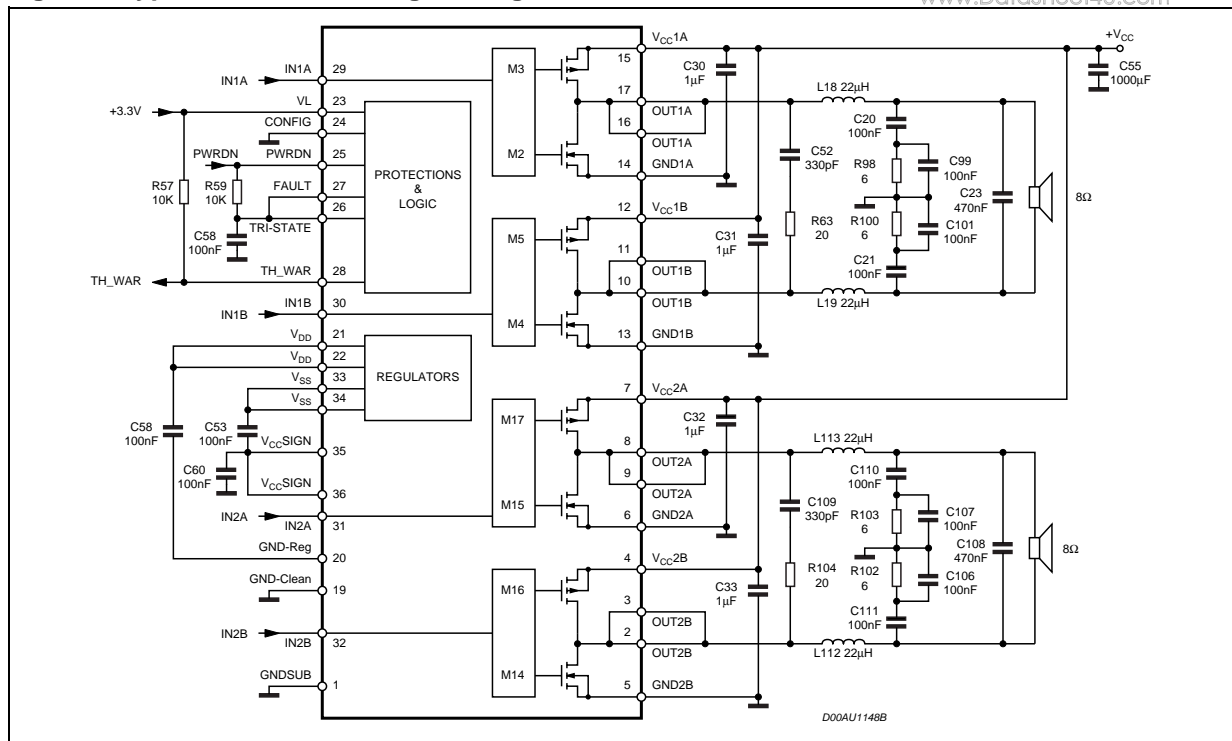
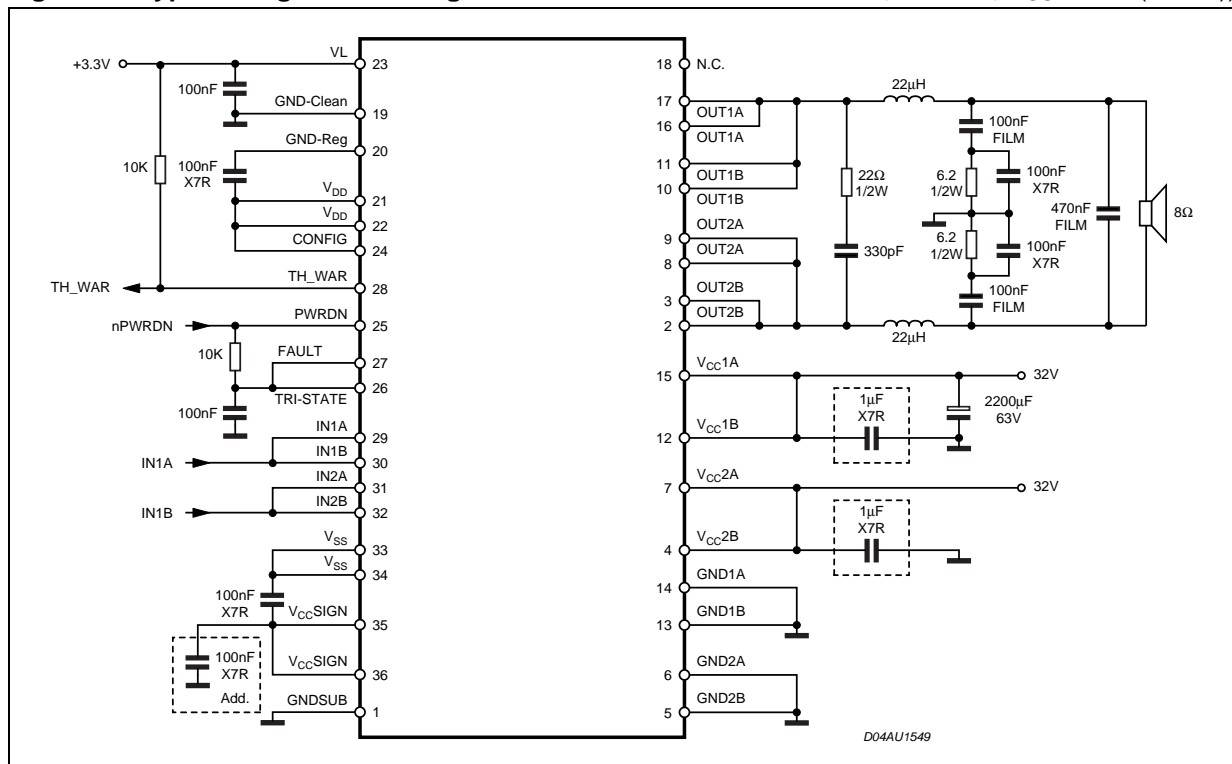

Figure 10. Typical Single BTL Configuration to obtain 60W @ THD 10%, $R_L = 8\Omega$, $V_{CC} = 32V$ (note 1))



Note: 1. "A PWM modulator as driver is needed . In particular, this result is performed using the STA308+STA515+STA50X demo board".
Peak Power for $t \leq 1\text{sec}$

4 THERMAL INFORMATION:

The power dissipated within the device depends primarily on the supply voltage, load impedance and output modulation level. The PSSO36 Package of the STA515 includes an exposed thermal slug on the top of the device to provide a direct thermal path from the IC to the heatsink.

For the Quad single ended application the Dissipated Power vs Output Power is shown in fig.11
 Considering that for the STA515 the Thermal resistance Junction to slug is 1.5°C/W and the estimated Thermal resistance due to the grease placed between slug and heat sink is 2.3°C/W (the use of thermal pads for this package is not recommended), the suitable Heat Sink Rth to be used can be drawn from the following graph fig 12, where is shown the Derating Power vs.Tambient for different heatsinkers.

5 CHARACTERIZATION CURVES

5.1 The following characterization are obtained using the quad single ended configuration (fig.2) with STA308A controller

Figure 11. Power Dissipation vs Output Power

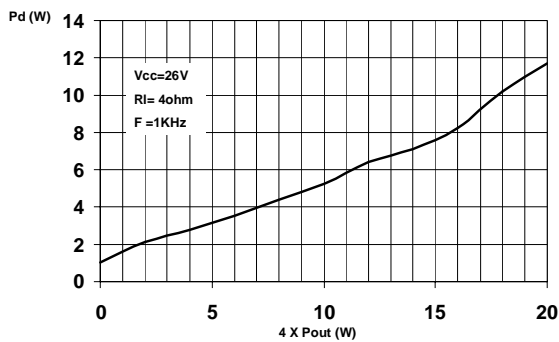

Figure 13. THD+N vs Output Power

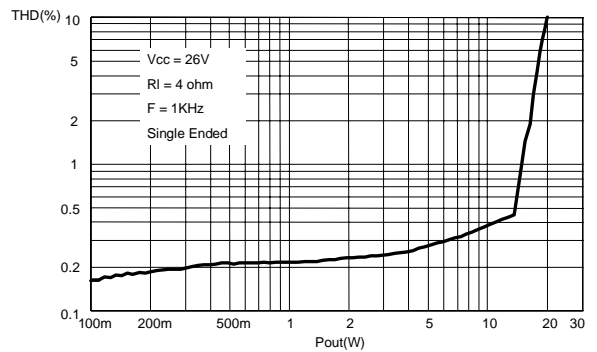

Figure 12. Power Derating Curve

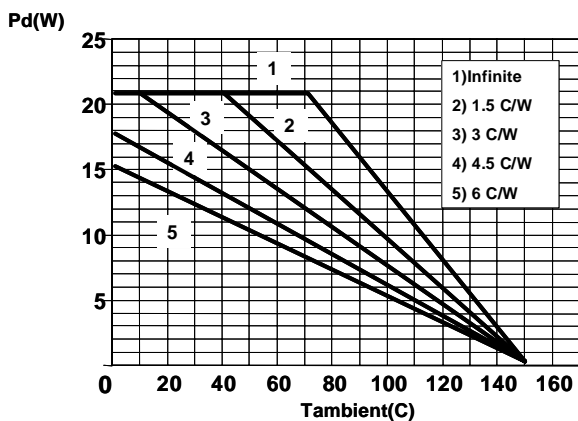

Figure 14. Output Power vs Supply Voltage

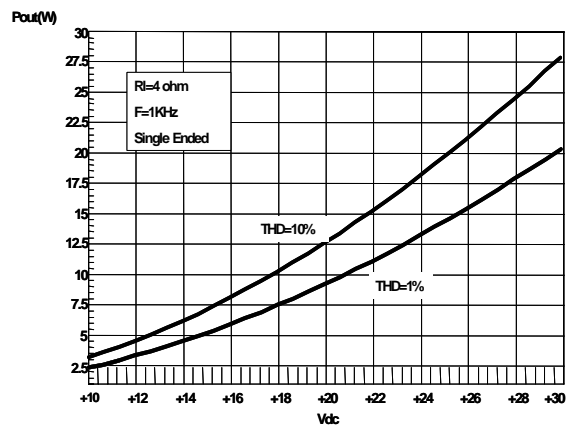
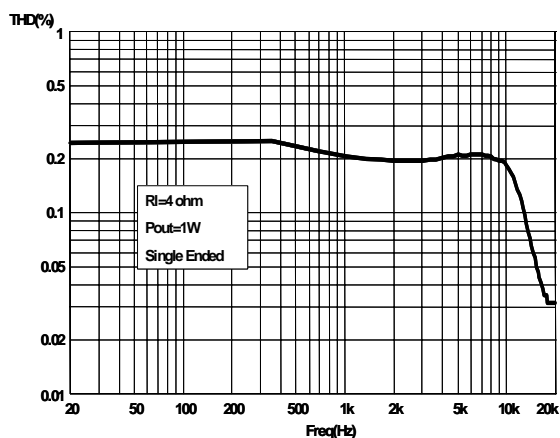

Figure 15. THD vs Frequency



5.2 The following characterizations are obtained using the stereo full bridge configuration (fig. 9) with STA308A controller

Figure 16. Output power vs Supply Voltage

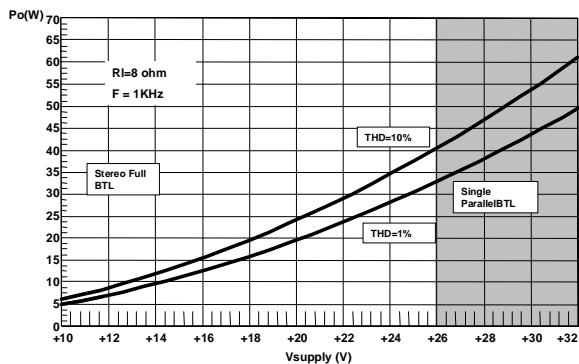

Figure 17. THD+N vs Output Power

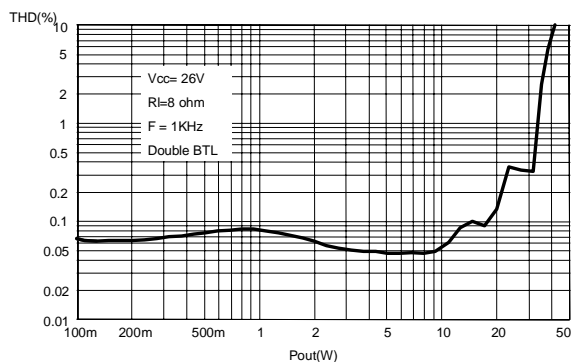
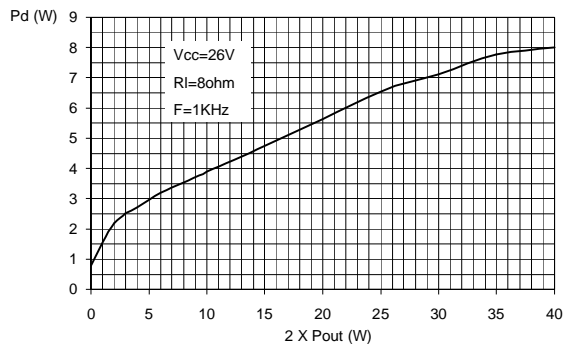

Figure 18. Power Dissipation vs Output Power



5.3 The following characterizations are obtained using the single BTL configuration (fig. 10) with STA308A controller

Figure 19. THD+N vs Output Power

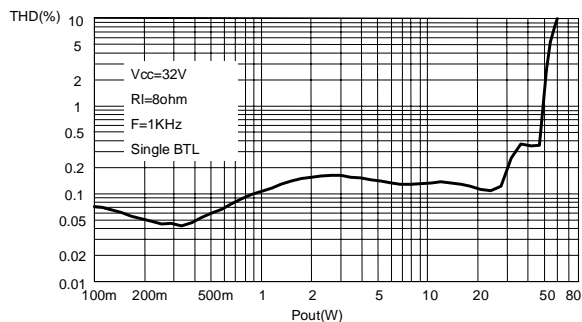
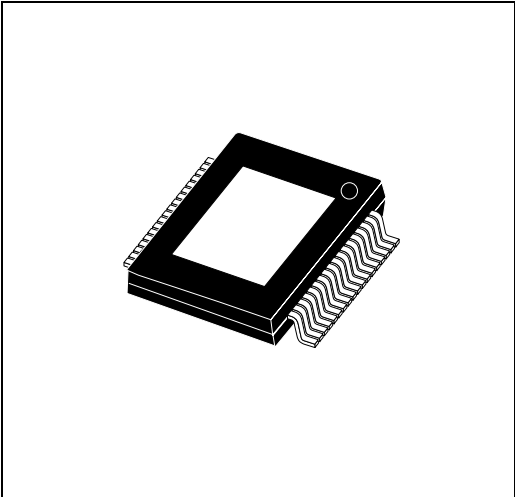

Figure 20. PowerSSO-36 (Slug Up) Mechanical Data & Package Dimensions www.DataSheet4U.com

DIM.	mm			inch		
	MIN.	TYP.	MAX.	MIN.	TYP.	MAX.
A	2.15		2.47	0.084		0.097
A2	2.15		2.40	0.084		0.094
a1	0		0.075	0		0.003
b	0.18		0.36	0.007		0.014
c	0.23		0.32	0.009		0.012
D (1)	10.10		10.50	0.398		0.413
E (1)	7.4		7.6	0.291		0.299
e		0.50			0.020	
e3		8.50			0.035	
F		2.3			0.090	
G			0.10			0.004
G1			0.06			0.002
H	10.10		10.50	0.398		0.413
h			0.40			0.016
L	0.55		0.85	0.022		0.033
M		4.3			0.169	
N	10° (max)					
O		1.2			0.047	
Q		0.8			0.031	
S		2.9			0.114	
T		3.65			0.144	
U		1.0			0.039	
X	4.10		4.70	0.161		0.185
Y	6.50		7.10	0.256		0.279

- (1) "D and E" do not include mold flash or protusions.
Mold flash or protusions shall not exceed 0.15mm (0.006")
- (2) No intrusion allowed inwards the leads.
- (3) Flash or bleeds on exposed die pad shall not exceed 0.4 mm per side

OUTLINE AND MECHANICAL DATA



PowerSSO-36 (slug-up)

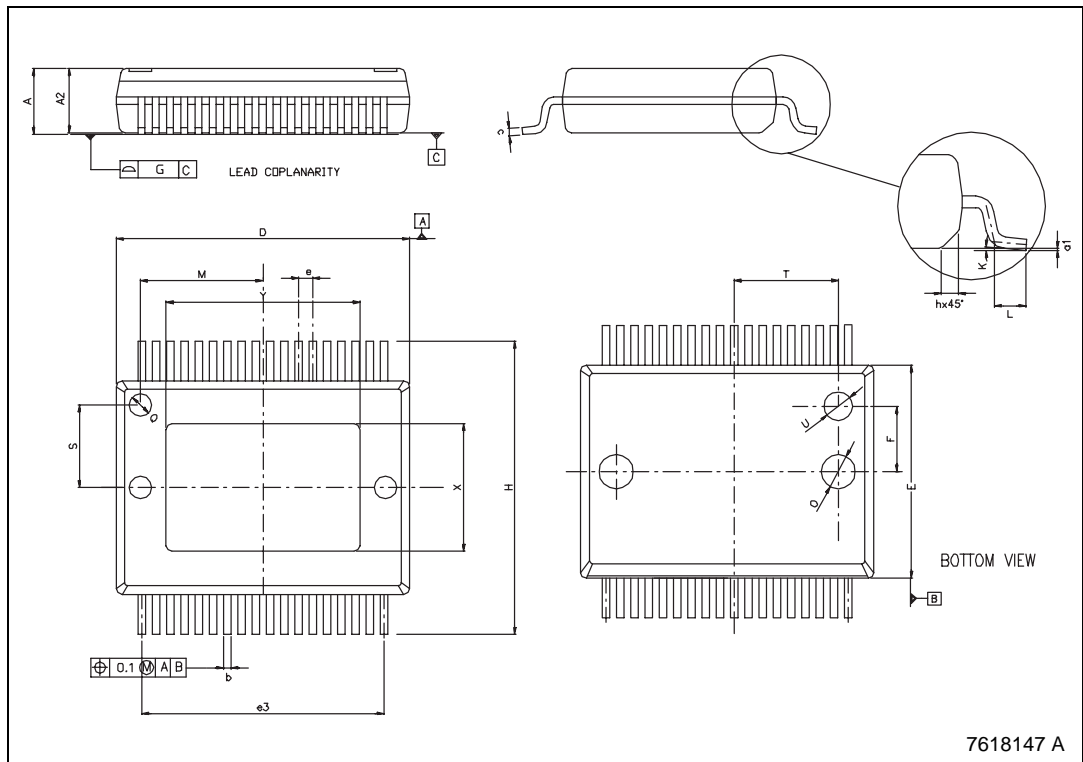

Table 9. Revision History

www.DataSheet4U.com

Date	Revision	Description of Changes
May 2004	1	First Issue
July 2004	2	Small change

Information furnished is believed to be accurate and reliable. However, STMicroelectronics assumes no responsibility for the consequences of use of such information nor for any infringement of patents or other rights of third parties which may result from its use. No license is granted by implication or otherwise under any patent or patent rights of STMicroelectronics. Specifications mentioned in this publication are subject to change without notice. This publication supersedes and replaces all information previously supplied. STMicroelectronics products are not authorized for use as critical components in life support devices or systems without express written approval of STMicroelectronics.

The ST logo is a registered trademark of STMicroelectronics.
All other names are the property of their respective owners

DDX is a trademark of Apogee technology inc.

© 2004 STMicroelectronics - All rights reserved

STMicroelectronics GROUP OF COMPANIES

Australia - Belgium - Brazil - Canada - China - Czech Republic - Finland - France - Germany - Hong Kong - India - Israel - Italy - Japan -
Malaysia - Malta - Morocco - Singapore - Spain - Sweden - Switzerland - United Kingdom - United States

www.st.com