

		REVISIONS										
		LTR	DESCRIPTION								DATE	APPROVED

REV	PAGE	REV STATUS OF PAGES	REV PAGES	1	2	3	4	5	6	7	8	9	10

Defense Electronics Supply Center Dayton, Ohio Original date of drawing: 3 October 1986 AMSC N/A	PREPARED BY <i>David W. Queenan</i>	MILITARY DRAWING This drawing is available for use by all Departments and Agencies of the Department of Defense
	CHECKED BY <i>DA DiConzo</i>	
	APPROVED BY <i>M. Hancock</i>	TITLE: MICROCIRCUIT, DIGITAL, ADVANCED SCHOTTKY TTL, MAGNITUDE COMPARATOR, MONOLITHIC SILICON
	SIZE A	CODE IDENT. NO. 14933
REV	PAGE 1 OF 10	

5962-E072-1

DISTRIBUTION STATEMENT A. Approved for public release; distribution is unlimited.

DESC FORM 193

1. SCOPE

1.1 Scope. This drawing describes device requirements for class B microcircuits in accordance with 1.2.1 of MIL-STD-883, "Provisions for the use of MIL-STD-883 in conjunction with compliant non-JAN devices".

1.2 Part number. The complete part number shall be as shown in the following example:

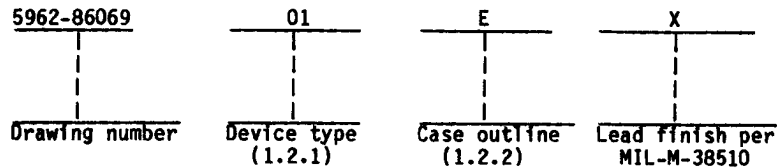

1.2.1 Device type. The device type shall identify the circuit function as follows:

Device type	Generic number	Circuit function
01	54F85	4-bit magnitude comparator

1.2.2 Case outlines. The case outlines shall be as designated in appendix C of MIL-M-38510, and as follows:

Outline letter	Case outline
E	D-2 (16-lead, 1/4" x 7/8"), dual-in-line package
F	F-5 (16-lead, 1/4" x 3/8"), flat package
2	C-2 (20-terminal, .350" x .350"), square chip carrier package

1.3 Absolute maximum ratings.

Supply voltage range - - - - -	-0.5 V dc to +7.0 V dc
Input voltage range- - - - -	-0.5 V dc at -18 mA to +7.0 V dc
Storage temperature- - - - -	-65°C to +150°C
Maximum power dissipation (P _D) per device ^{1/} - - - - -	297 mW
Lead temperature (soldering, 10 seconds) - - - - -	+300°C
Thermal resistance, junction-to-case (θ _{JC}):	
Cases E and F- - - - -	See MIL-M-38510, appendix C
Case 2 - - - - -	80°C/W ^{2/}
Junction temperature (T _J) - - - - -	+175°C

1.4 Recommended operating conditions.

Supply voltage (V _{CC}) - - - - -	4.5 V dc minimum to 5.5 V dc maximum
Minimum high level input voltage (V _{IH}) - - - - -	2.0 V dc
Maximum low level input voltage (V _{IL}) - - - - -	0.8 V dc
Case operating temperature range (T _C) - - - - -	-55°C to +125°C

^{1/} Must withstand the added P_D due to short circuit test (e.g., I_{GS}).

^{2/} When a thermal resistance for this case is specified in MIL-M-38510, appendix C, that value shall supersede the value specified herein.

MILITARY DRAWING DEFENSE ELECTRONICS SUPPLY CENTER DAYTON, OHIO	SIZE A	CODE IDENT. NO. 14933	DWG NO. 5962-86069
		REV	PAGE 2

DESC FORM 193A
FEB 86

2. APPLICABLE DOCUMENTS

2.1 Government specification and standard. Unless otherwise specified, the following specification and standard, of the issue listed in that issue of the Department of Defense Index of Specifications and Standards specified in the solicitation, form a part of this drawing to the extent specified herein.

SPECIFICATION

MILITARY

MIL-M-38510 - Microcircuits, General Specification for.

STANDARD

MILITARY

MIL-STD-883 - Test Methods and Procedures for Microelectronics.

(Copies of the specification and standard required by manufacturers in connection with specific acquisition functions should be obtained from the contracting activity or as directed by the contracting activity.)

2.2 Order of precedence. In the event of a conflict between the text of this drawing and the references cited herein, the text of this drawing shall take precedence.

3. REQUIREMENTS

3.1 Item requirements. The individual item requirements shall be in accordance with 1.2.1 of MIL-STD-883, "Provisions for the use of MIL-STD-883 in conjunction with compliant non-JAN devices" and as specified herein.

3.2 Design, construction, and physical dimensions. The design, construction, and physical dimensions shall be as specified in MIL-M-38510 and herein.

3.2.1 Terminal connections. The terminal connections shall be as specified on figure 1.

3.2.2 Truth table. The truth table shall be as specified on figure 2.

3.2.3 Logic diagram. The logic diagram shall be as specified on figure 3.

3.2.4 Case outlines. The case outlines shall be in accordance with 1.2.2 herein.

3.3 Electrical performance characteristics. Unless otherwise specified, the electrical performance characteristics are as specified in table I and apply over the full recommended case operating temperature range.

3.4 Marking. Marking shall be in accordance with MIL-STD-883 (see 3.1 herein). The part shall be marked with the part number listed in 1.2 herein. In addition, the manufacturer's part number may also be marked as listed in 6.4 herein.

MILITARY DRAWING DEFENSE ELECTRONICS SUPPLY CENTER DAYTON, OHIO	SIZE A	CODE IDENT. NO. 14933	DWG NO. 5962-86069
		REV	PAGE 3

DESC FORM 193A
FEB 86

TABLE I. Electrical performance characteristics.

Test	Symbol	Conditions -55°C < T _C < +125°C unless otherwise specified	Group A subgroups	Limits		Unit
				Min	Max	
High level output voltage	V _{OH}	V _{CC} = 4.5 V; I _{OH} = -1 mA V _{IN} = 0.8 V or 2.0 V	1,2,3	2.5		V
Low level output voltage	V _{OL}	V _{CC} = 4.5 V; I _{OL} = 20 mA V _{IN} = 0.8 V or 2.0 V	1,2,3		0.5	V
Input clamp voltage	V _{IC}	V _{CC} = 4.5 V I _{IN} = -18 mA; T _C = +25°C	1		-1.2	V
High level input current	I _{IH1}	V _{CC} = 5.5 V; V _{IN} = 7.0 V	1,2,3		100	μA
	I _{IH2}	V _{CC} = 5.5 V; V _{IN} = 2.7 V	1,2,3		20	μA
Low level input current	I _{IL}	V _{CC} = 5.5 V; V _{IN} = 0.5 V	1,2,3		-20	μA
Short circuit output current	I _{OS}	V _{CC} = 5.5 V; V _{OUT} = GND 1/	1,2,3	-60	-150	mA
Supply current	I _{CCH}	V _{CC} = 5.5 V	1,2,3		50	mA
	I _{CCL}		1,2,3		54	mA
Functional tests		See 4.4.1c	7			
Propagation delay time, A or B to A < B or A > B	t _{PLH1}	V _{CC} = 5.0 V R _L = 500Ω ±5% C _L = 50 pF ±10%	9		16	ns
			10,11		21	ns
	9			16	ns	
	10,11			21	ns	
Propagation delay time, A or B to A = B	t _{PLH2}	9		16	ns	
		10,11		21	ns	
	9		14	ns		
	10,11		17	ns		
Propagation delay time, 1A < B or 1A = B to A > B	t _{PLH3}	9		9	ns	
		10,11		12	ns	
	9		8	ns		
	10,11		10	ns		
Propagation delay time, 1A = B to A = B	t _{PLH4}	9		8	ns	
		10,11		14	ns	
	9		10	ns		
	10,11		12	ns		
Propagation delay time, 1A > B or 1A = B to A < B	t _{PLH5}	9		9	ns	
		10,11		14	ns	
	9		9	ns		
	10,11		10	ns		

1/ Not more than one output should be shorted at a time, and the duration of the short circuit condition should not exceed one second.

MILITARY DRAWING DEFENSE ELECTRONICS SUPPLY CENTER DAYTON, OHIO	SIZE A	CODE IDENT. NO. 14933	DWG NO. 5962-86069
		REV	PAGE 4

DESC FORM 183A
FEB 86

3.5 Certificate of compliance. A certificate of compliance shall be required from a manufacturer in order to be listed as an approved source of supply in 6.4. The certificate of compliance submitted to DESC-ECS prior to listing as an approved source of supply shall state that the manufacturer's product meets the requirements of MIL-STD-883 (see 3.1 herein) and the requirements herein.

3.6 Certificate of conformance. A certificate of conformance as required in MIL-STD-883 (see 3.1 herein) shall be provided with each lot of microcircuits delivered to this drawing.

3.7 Notification of change. Notification of change to DESC-ECS shall be required in accordance with MIL-STD-883 (see 3.1 herein).

3.8 Verification and review. DESC, DESC's agent, and the acquiring activity retain the option to review the manufacturer's facility and applicable required documentation. Offshore documentation shall be made available onshore at the option of the reviewer.

4. QUALITY ASSURANCE PROVISIONS

4.1 Sampling and inspection. Sampling and inspection procedures shall be in accordance with section 4 of MIL-M-38510 to the extent specified in MIL-STD-883 (see 3.1 herein).

4.2 Screening. Screening shall be in accordance with method 5004 of MIL-STD-883, and shall be conducted on all devices prior to quality conformance inspection. The following additional criteria shall apply:

a. Burn-in test (method 1015 of MIL-STD-883).

(1) Test condition A, B, C or D using the circuit submitted with the certificate of compliance (see 3.5 herein).

(2) $T_A = +125^\circ\text{C}$, minimum.

b. Interim and final electrical test parameters shall be as specified in table II herein, except interim electrical parameter tests prior to burn-in are optional at the discretion of the manufacturer.

4.3 Quality conformance inspection. Quality conformance inspection shall be in accordance with method 5005 of MIL-STD-883 including groups A, B, C, and D inspections. The following additional criteria shall apply.

4.3.1 Group A inspection.

a. Tests shall be as specified in table II herein.

b. Subgroups 4, 5, 6, and 8 in table I, method 5005 of MIL-STD-883 shall be omitted.

c. Subgroup 7 tests shall verify the truth table.

4.3.2 Groups C and D inspections.

a. End-point electrical parameters shall be as specified in table II herein.

b. Steady-state life test (method 1005 of MIL-STD-883) conditions:

(1) Test condition A, B, C or D using the circuit submitted with the certificate of compliance (see 3.5 herein).

(2) $T_A = +125^\circ\text{C}$, minimum.

(3) Test duration: 1,000 hours, except as permitted by appendix B of MIL-M-38510 and method 1005 of MIL-STD-883.

MILITARY DRAWING DEFENSE ELECTRONICS SUPPLY CENTER DAYTON, OHIO	SIZE A	CODE IDENT. NO. 14933	DWG NO. 5962-86069
		REV	PAGE 5

DESC FORM 193A
FEB 86

Cases E and F

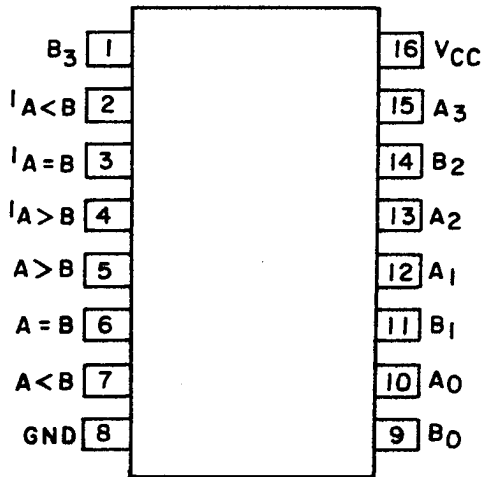

Case 2

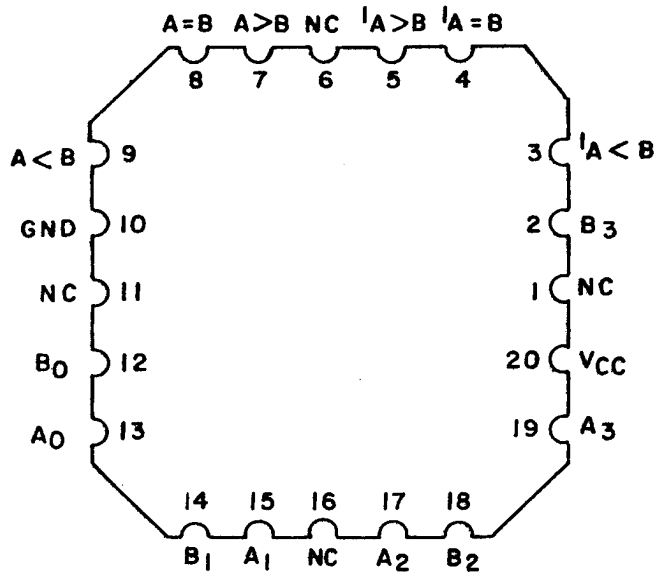

FIGURE 1. Terminal connections (top view).

MILITARY DRAWING DEFENSE ELECTRONICS SUPPLY CENTER DAYTON, OHIO	SIZE A	CODE IDENT. NO. 14933	DWG NO. 5962-86069
		REV	PAGE 6

DESC FORM 193A
FEB 86

Comparing inputs			Cascading inputs			Outputs			
A ₃ , B ₃	A ₂ , B ₁	A ₁ , B ₁	A ₀ , B ₀	A > B	A < B	A = B	A > B	A < B	A = B
A ₃ > B ₃	X	X	X	X	X	X	H	L	L
A ₃ < B ₃	X	X	X	X	X	X	L	H	L
A ₃ = B ₃				X	X	X	L	L	L
A ₃ > B ₃	A ₂ > B ₂	A ₁ > B ₁	A ₀ > B ₀	X	X	X	L	L	L
A ₃ < B ₃	A ₂ < B ₂	A ₁ < B ₁	A ₀ < B ₀	X	X	X	L	L	L
A ₃ = B ₃	A ₂ = B ₂	A ₁ = B ₁	A ₀ = B ₀	X	X	X	L	L	L
A ₃ > B ₃	A ₂ = B ₂	A ₁ = B ₁	A ₀ = B ₀	X	X	X	L	L	L
A ₃ < B ₃	A ₂ = B ₂	A ₁ = B ₁	A ₀ = B ₀	X	X	X	L	L	L
A ₃ = B ₃	A ₂ = B ₂	A ₁ = B ₁	A ₀ = B ₀	X	X	X	L	L	L
A ₃ > B ₃	A ₂ = B ₂	A ₁ = B ₁	A ₀ = B ₀	X	X	X	L	L	L
A ₃ < B ₃	A ₂ = B ₂	A ₁ = B ₁	A ₀ = B ₀	X	X	X	L	L	L
A ₃ = B ₃	A ₂ = B ₂	A ₁ = B ₁	A ₀ = B ₀	X	X	X	L	L	L
A ₃ > B ₃	A ₂ = B ₂	A ₁ = B ₁	A ₀ = B ₀	X	X	X	L	L	L
A ₃ < B ₃	A ₂ = B ₂	A ₁ = B ₁	A ₀ = B ₀	X	X	X	L	L	L
A ₃ = B ₃	A ₂ = B ₂	A ₁ = B ₁	A ₀ = B ₀	X	X	X	L	L	L
A ₃ > B ₃	A ₂ = B ₂	A ₁ = B ₁	A ₀ = B ₀	X	X	X	L	L	L
A ₃ < B ₃	A ₂ = B ₂	A ₁ = B ₁	A ₀ = B ₀	X	X	X	L	L	L
A ₃ = B ₃	A ₂ = B ₂	A ₁ = B ₁	A ₀ = B ₀	X	X	X	L	L	L

H = HIGH voltage level
 L = LOW voltage level
 X = Don't care

FIGURE 2. Truth table.

MILITARY DRAWING DEFENSE ELECTRONICS SUPPLY CENTER DAYTON, OHIO	SIZE	CODE IDENT. NO.	DWG NO.
	A	14933	5962-86069
	REV	PAGE 7	

DESC FORM 193A
 FEB 86

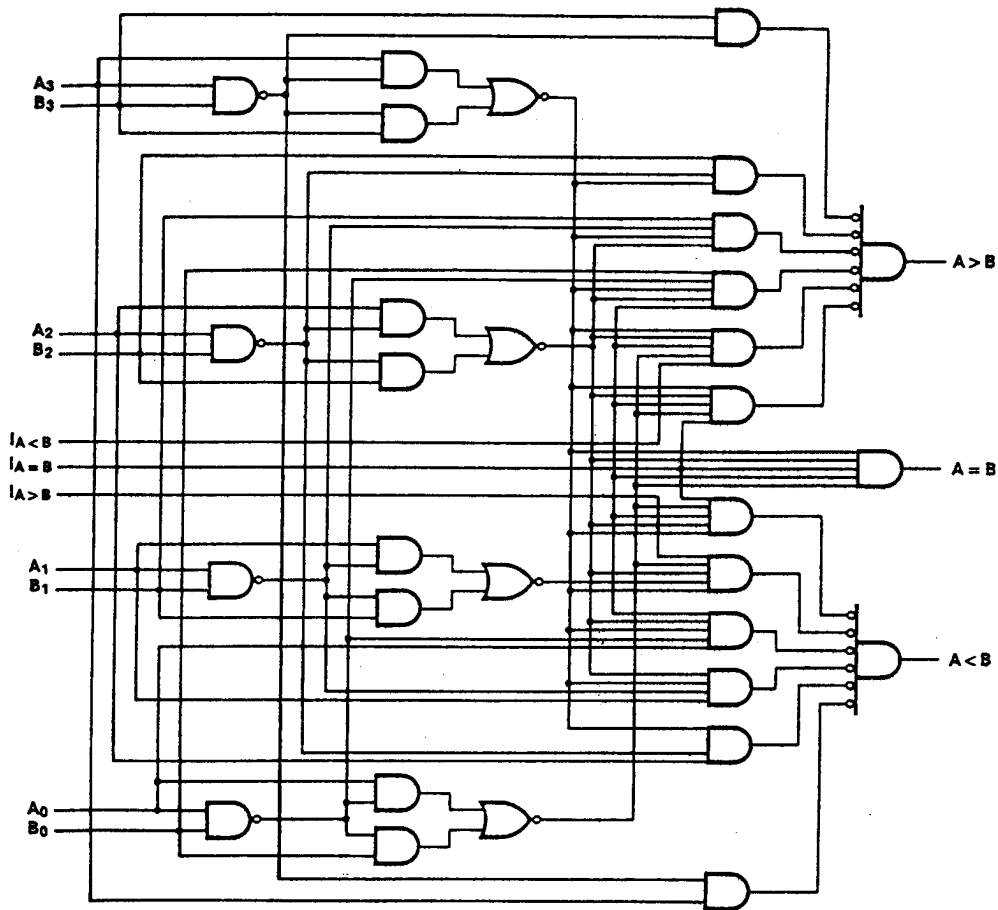

FIGURE 3. Logic diagram.

MILITARY DRAWING DEFENSE ELECTRONICS SUPPLY CENTER DAYTON, OHIO	SIZE A	CODE IDENT. NO. 14933	DWG NO. 5962-86069
		REV	PAGE 8

DESC FORM 183A
FEB 66

TABLE II. Electrical test requirements.

MIL-STD-883 test requirements	Subgroups (per method 5005, table I)
Interim electrical parameters (method 5004)	---
Final electrical test parameters (method 5004)	1*, 2, 3, 9
Group A test requirements (method 5005)	1, 2, 3, 7, 9 10, 11**
Groups C and D end-point electrical parameters (method 5005)	1, 2, 3

*PDA applies to subgroup 1.

**Subgroups 10 and 11, if not tested, shall be guaranteed to the specified limits in table I.

5. PACKAGING

5.1 Packaging requirements. The requirements for packaging shall be in accordance with MIL-M-38510.

6. NOTES

6.1 Intended use. Microcircuits conforming to this drawing are intended for use when military specifications do not exist and qualified military devices that will perform the required function are not available for OEM application. When a military specification exists and the product covered by this drawing has been qualified for listing on QPL-38510, the device specified herein will be inactivated and will not be used for new design. The QPL-38510 product shall be the preferred item for all applications.

6.2 Replaceability. Microcircuits covered by this drawing will replace the same generic device covered by a contractor-prepared specification or drawing.

6.3 Comments. Comments on this drawing should be directed to DESC-ECS, Dayton, Ohio 45444, or telephone 513-296-5375.

MILITARY DRAWING DEFENSE ELECTRONICS SUPPLY CENTER DAYTON, OHIO	SIZE	CODE IDENT. NO.	DWG NO.
	A	14933	5962-86069
		REV	PAGE 9

DESC FORM 193A
FEB 86

6.4 Approved source of supply. An approved source of supply is listed herein. Additional sources will be added as they become available. The vendor listed herein has agreed to this drawing and a certificate of compliance (see 3.5 herein) has been submitted to DESC-ECS.

Military drawing part number	Vendor CAGE number	Vendor similar part number <u>1/</u>
5962-8606901EX	18324	54F85/BEA
5962-8606901FX	18324	54F85/BFA
5962-86069012X	18324	54F85/B2C

1/ Caution. Do not use this number for item acquisition. Items acquired to this number may not satisfy the performance requirements of this drawing.

Vendor CAGE number

18324

Vendor name and address

Signetics Corporation
4130 S. Market Court
Sacramento, CA

MILITARY DRAWING DEFENSE ELECTRONICS SUPPLY CENTER DAYTON, OHIO	SIZE A	CODE IDENT. NO. 14933	DWG NO. 5962-86069
		REV	PAGE 10

DESC FORM 183A
FEB 88

011992 _ _ _