

PLEASE CHECK WWW.MOLEX.COM FOR LATEST PART INFORMATION

Part Number: [0082265804](#)
Status: **Active**
Description: 2.54mm (.100") Pitch Round Conductor Flat Cable - 26 AWG (7 x 34) Stranded, Topcoat, 4 Circuits, Reel 30.48m (100.0') Length

Documents:

[Drawing \(PDF\)](#) [RoHS Certificate of Compliance \(PDF\)](#)

Agency Certification

CSA LR61126
 UL E61522

General

Product Family Cable
 Series [8996](#)
 Crimp Quality Equipment Yes
 Geographic Area Asia
 Product Name Ribbon

Physical

Cable Length 30.48m (100.0')
 Circuits (Loaded) 4
 Insulation PVC
 Packaging Type Reel
 Pitch - Term. Interface (in) 0.100 In
 Pitch - Term. Interface (mm) 2.54 mm
 Temperature Range - Operating -20°C to +105°C
 Wire Size AWG 26
 Wire/Cable Type (7x34) Stranded, Topcoat

Electrical

Current - Maximum per Contact N/A
 Voltage - Maximum 300V

Material Info

Old Part Number 8996-04-100B

Reference - Drawing Numbers

Sales Drawing SD-8996-001



EU RoHS

**ELV and RoHS
 Compliant**
REACH SVHC
 Not Reviewed
**Halogen-Free
 Status**
 Not Reviewed

China RoHS



Need more information on product environmental compliance?

Email productcompliance@molex.com
 For a multiple part number RoHS Certificate of Compliance, [click here](#)

Please visit the [Contact Us](#) section for any non-product compliance questions.

Search Parts in this Series

[8996Series](#)

Use With

[70400](#) C-Grid SL™ IDT Connector Assembly. [70475](#) SL™ IDT Connector Assembly. [7720](#) KK® IDT Double Cantilever Contact

ONE EDGE MUST BE MARKED WITH RED
(REELS MFG. IN NOG.CAN BE MARKED WITH BLACK)

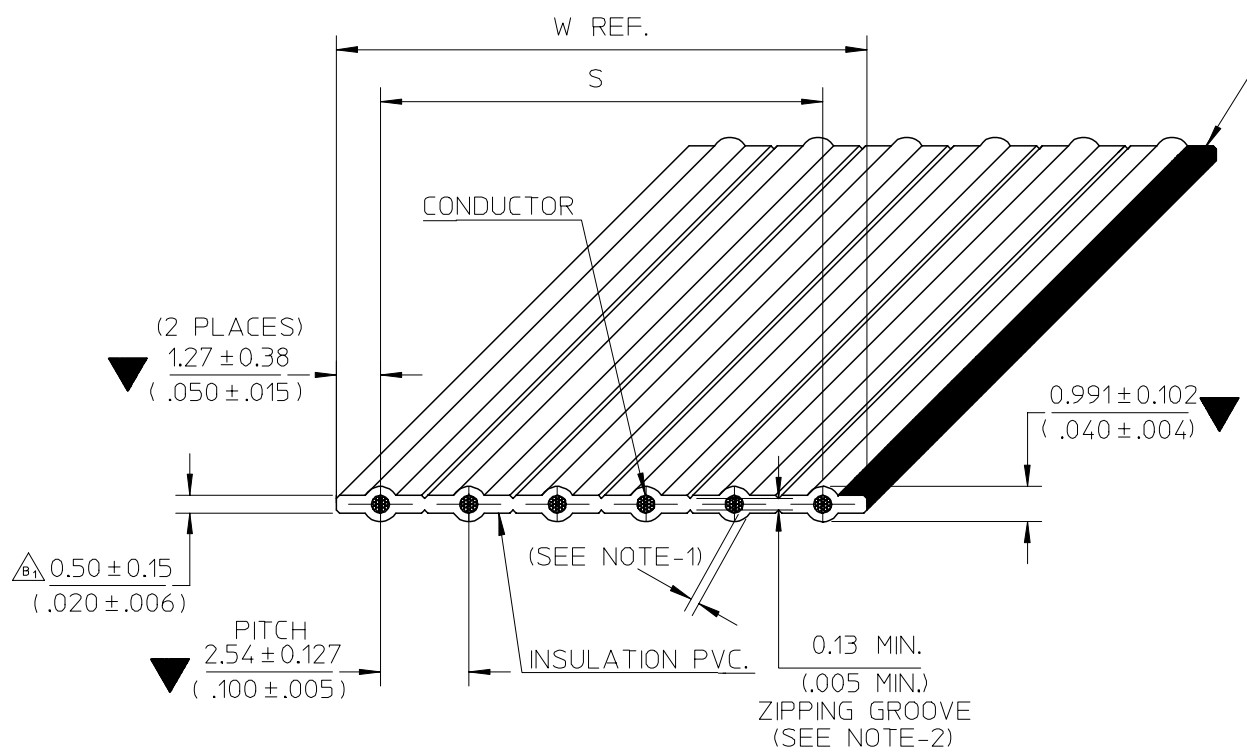

- NOTE :**
1. THE CABLE SHALL HAVE A MINIMUM OF 0.178mm. (.007") THICKNESS INSULATION AT ANY POINT
 2. RIP TEST:
- THE 0.13mm. (.005") ZIPPING GROOVE SHALL BE CAPABLE OF BEING RIPPED BY HAND WITHIN THE RECESS,WITHOUT EXPOSING THE ADJACENT CONDUCTORS
 3. RoHS AND LEAD FREE COMPLIANT
 4. SPECIAL REQUIREMENT: N/A

B	E-07-0748	B ₃ : ADD NON-OPERATING TEMP. B ₂ : ADD SOLDERING CONDITION B ₁ : CHANGE WEB THICKNESS	07/09/26
A	N/A	NEW RELEASE	06/07/18
REV. HISTORY	EC NO.	DETAIL	DATE

SEE CHANGE DETAIL
EC NO: THL2008-0015
DRWN:CPANSAKHOM 2007/11/28
CHKD:DNARINTARA 2007/11/29
APPR:SVIRATJAPOL 2007/12/04

QUALITY SYMBOLS
▽=3
▽=0
DESCRIPTION
REV

GENERAL TOLERANCES (UNLESS SPECIFIED)	
	mm INCH
4 PLACES	± --- ± ---
3 PLACES	± --- ± ---
2 PLACES	± --- ± ---
1 PLACE	± --- ± ---
ANGULAR ± ---°	
DRAFT WHERE APPLICABLE MUST REMAIN WITHIN DIMENSIONS	

DIMENSION STYLE	
MM/IN	
DRAWN BY	DATE
CPANSAKHOM	2006/07/18
CHECKED BY	DATE
PMEECHAI	2006/07/18
APPROVED BY	DATE
SVIRATJAPOL	2006/07/18
MATERIAL NO.	
SEE CHART	
SIZE	
A/4	

SCALE	DESIGN UNITS	THIRD ANGLE PROJECTION
NTS	INCH	
TITLE		
FCB ROUND CONDUCTOR 2.54MM(.100)CENTER PVC. 26AWG STRANDED TOPCOATED		
MOLEX INCORPORATED		
MATERIAL NO.	DOCUMENT NO.	SHEET NO.
SEE CHART	SD-8996-001	1 OF 3
THIS DRAWING CONTAINS INFORMATION THAT IS PROPRIETARY TO MOLEX INCORPORATED AND SHOULD NOT BE USED WITHOUT WRITTEN PERMISSION		

7

6

5

4

3

2

1

SPECIFICATIONS

PHYSICAL

CONDUCTOR SPACING2.54 (.100") ϵ TO ϵ
WIRE GAUGE26 AWG(7/34) STRANDED TOPCOATED
INSULATIONP.V.C GRAY (LEAD FREE)

AGENCY

U.L. STYLE NO.2651
TEMPERATURE RATING-20°C TO 105°C
VOLTAGE RATING300V.MAX.
FLAMMABILITY RATINGVW-1

ELECTRICAL

CONDUCTOR RESISTANCE (D.C.)43m. OHMS/FT. MAX.
CHARACTERISTIC IMPEDANCE145 OHMS NOM. (GS)
.....123 OHMS NOM. (GSG)
CAPACITANCE5.6 pF/FT. NOM. (GS)
.....10.3 pF/FT. NOM. (GSG)
PROPAGATION DELAY1.4 ns/FT. NOM.
INSULATION RESISTANCE10M OHMS (10FT. SAMPLE)
DIELECTRIC WITHSTAND VOLTAGE2000 VRMS/MINUTE

GENERAL

Δ_{B_1} NON-OPERATING TEMPERATURE-20°C TO 105°C
FAULTS AND/OR SPLICES1/REEL MAX. 100 \pm 3 FT. (30.48 \pm 0.914 M.)/REEL
20FT. (6.096M.) MIN. LENGTH

Δ_{B_2} SOLDERING CONDITION

SOLDER TEMPERATURE260°C. MAX.
SOLDERING TIME3 SECOND, MAX.
INSULATION SHRINK2MM. NOM.

SEE CHANGE DETAIL EC NO: THL2008-0015 DRAWN: CPANSAKHOM 2007/11/28 CHKD: DNARINTARA 2007/11/29 APPR: SVIRATJAPOL 2007/12/04	QUALITY SYMBOLS \blacktriangledown = \triangleleft =	GENERAL TOLERANCES (UNLESS SPECIFIED)		DIMENSION STYLE MM/IN		SCALE NTS	DESIGN UNITS INCH	THIRD ANGLE PROJECTION		
		4 PLACES	\pm ---	\pm ---	DRAWN BY CPANSAKHOM	DATE 2006/07/18	TITLE FCB ROUND CONDUCTOR 2.54MM(.100)CENTER PVC. 26AWG STRANDED TOPCOATED			
		3 PLACES	\pm ---	\pm ---	CHECKED BY PMEECHAI	DATE 2006/07/18				
		2 PLACES	\pm ---	\pm ---	APPROVED BY SVIRATJAPOL		DATE 2006/07/18	MOLEX INCORPORATED		
1 PLACE	\pm ---	\pm ---	ANGULAR \pm ---°		MATERIAL NO. SEE CHART		DOCUMENT NO. SD-8996-001	SHEET NO. 2 OF 3		
DRAFT WHERE APPLICABLE MUST REMAIN WITHIN DIMENSIONS				THIS DRAWING CONTAINS INFORMATION THAT IS PROPRIETARY TO MOLEX INCORPORATED AND SHOULD NOT BE USED WITHOUT WRITTEN PERMISSION						

6

5

4

3

2

1

E

E

D

D

C

C

B

B

A

A

7 6 5 4 3 2 1

E
D
C
B
A

E
D
C
B
A

CHART A				
DIMENSIONS MM. (INCHES)				
ENGINEERING NO.	ORDER NO.	NO. OF CONDUCTOR	DIMENSION S	DIM. W (REF.)
8996-02-100B	82-26-5802	2	2.54±0.127 (.100±.005)	5.08 (.200)
↑ -03- ↑	↑ 03	3	5.08±0.20 (.200±.008)	7.62 (.300)
-04-	04	4	7.62±0.30 (.300±.012)	10.16 (.400)
-05-	05	5	10.16±0.33 (.400±.013)	12.70 (.500)
-06-	06	6	12.70±0.33 (.500±.013)	15.24 (.600)
-07-	07	7	15.24±0.33 (.600±.013)	17.78 (.700)
-08-	08	8	17.78±0.33 (.700±.013)	20.32 (.800)
-09-	09	9	20.32±0.33 (.800±.013)	22.86 (.900)
-10-	10	10	22.86±0.33 (.900±.013)	25.40 (1.000)
-11-	11	11	25.40±0.33 (1.000±.013)	27.94 (1.100)
-12-	12	12	27.94±0.33 (1.100±.013)	30.48 (1.200)
-13-	13	13	30.48±0.33 (1.200±.013)	33.02 (1.300)
-14-	14	14	33.02±0.33 (1.300±.013)	35.56 (1.400)
-15-	15	15	35.56±0.33 (1.400±.013)	38.10 (1.500)
-16-	16	16	38.10±0.33 (1.500±.013)	40.64 (1.600)
-17-	17	17	40.64±0.33 (1.600±.013)	43.18 (1.700)
-18-	18	18	43.18±0.33 (1.700±.013)	45.72 (1.800)
↓ -19- ↓	↓ 19	19	45.72±0.33 (1.800±.013)	48.26 (1.900)
8996-20-100B	82-26-5820	20	48.26±0.33 (1.900±.013)	50.80 (2.000)

ENGINEERING NO.

8996-XX-XXXX
A B C D

A : CABLE 2.54mm. (.100") CENTERS 26AWG STRANDED TOPCOATED
 B : CONDUCTOR SIZE (AVAILABILITY 2 THROUGH 20)
 C : CABLE LENGTH 100FT. (30.48M.)
 D : A = INCHES
 B = FEET

SEE CHANGE DETAIL EC NO: THL2008-0015 DRWN: CPANSAKHOM 2007/11/28 CHKD: DNARINTARA 2007/11/29 APPR: SVIRATJAPOL 2007/12/04	QUALITY SYMBOLS	GENERAL TOLERANCES (UNLESS SPECIFIED)		DIMENSION STYLE	SCALE	DESIGN UNITS	THIRD ANGLE PROJECTION	
	▼ = ▽ =	mm	INCH	MM/IN	NTS	INCH		
		4 PLACES ± ---	± ---	DRAWN BY	DATE	TITLE		
		3 PLACES ± ---	± ---	CPANSAKHOM	2006/07/18	FCB ROUND CONDUCTOR 2.54MM(.100)CENTER PVC. 26AWG STRANDED TOPCOATED		
		2 PLACES ± ---	± ---	CHECKED BY	DATE	MOLEX INCORPORATED		
	1 PLACE ± ---	± ---	PMEECHAI	2006/07/18				
	ANGULAR ± ---°	DRAFT WHERE APPLICABLE MUST REMAIN WITHIN DIMENSIONS		APPROVED BY	DATE	DOCUMENT NO.		
				SVIRATJAPOL	2006/07/18	SD-8996-001		
				MATERIAL NO.	SHEET NO.			
				SEE CHART	3 OF 3			
				SIZE	THIS DRAWING CONTAINS INFORMATION THAT IS PROPRIETARY TO MOLEX INCORPORATED AND SHOULD NOT BE USED WITHOUT WRITTEN PERMISSION			
				A 4				

6 5 4 3 2 1