

MC33566

Smart Voltage Regulator for Peripheral Card Applications

The MC33566 Low Dropout Regulator is designed for computer peripheral card applications complying with the *instantly available requirements* as specified by ACPI objectives. The MC33566 permits glitch-free transitions from “sleep” to “active” system modes and has internal logic circuitry to detect whether the system is being powered from the motherboard main 5.0 V power supply or the 3.3 V aux supply.

The MC33566 provides a regulated output voltage of 3.3 V via either an internal low dropout 5.0 V-to-3.3 V voltage regulator or an external P-channel MOSFET, depending on the operating status of the system in which the card is installed. During normal operating mode (5.0 V main supply available) the 3.3 V output is provided from the internal low dropout regulator at an output current of 0.4 A. When the motherboard enters sleep mode, the MC33566 operates from the 3.3 V aux supply and routes the aux current to the output via the external P-channel MOSFET bypass transistor controlled by the *drive out* pin. As a result, the output voltage provided to the peripheral card remains constant at 3.3 V even during host systems transitions to and from sleep mode.

MC33566 Features:

- Output Current up to 0.4 A
- Excellent Line and Load Regulation
- Low Dropout Voltage
- Prevents Reverse Current Flow During Sleep Mode
- Glitch-Free Transfer from Sleep Mode to Active Mode
- Compatible with *Instantly Available* PC Systems

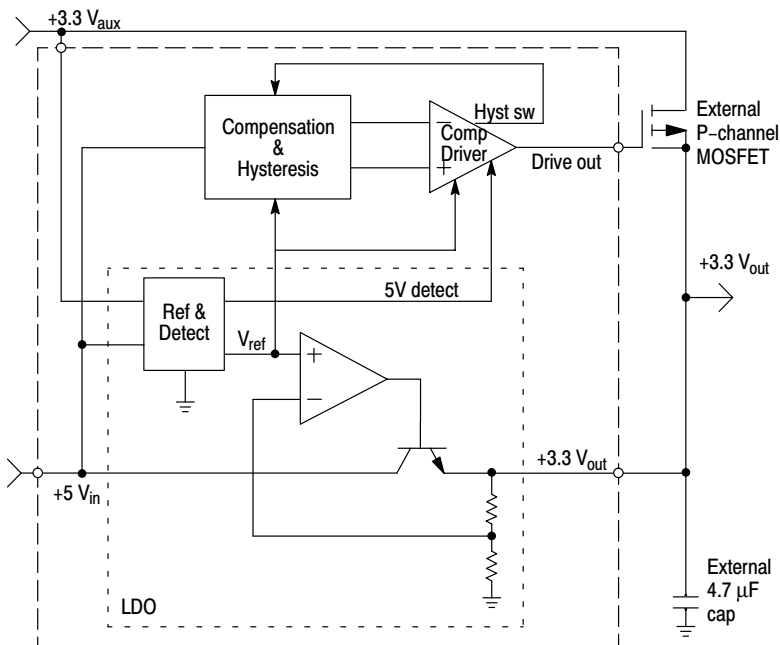

Figure 1. Simplified Block Diagram



ON Semiconductor®

<http://onsemi.com>

MARKING DIAGRAM

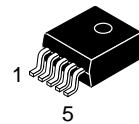

D²PAK
D2T SUFFIX
CASE 936A

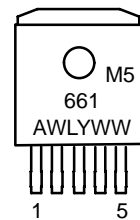

Pin 1. Vaux
2. Vin
3. Gnd
4. Vout
5. Drv

Note: Tab is ground

A = Assembly Location
WL = Wafer Lot
Y = Year
WW = Work Week

ORDERING INFORMATION

Device	Package	Shipping†
MC33566D2T-1	D ² PAK	50 Units/Rail
MC33566D2T-1RK	D ² PAK	800 Tape & Reel

†For information on tape and reel specifications, including part orientation and tape sizes, please refer to our Tape and Reel Packaging Specification Brochure, BRD8011/D.

MC33566

PIN ASSIGNMENTS AND FUNCTIONS

Pin #	Pin Name	Pin Description
1	+3.3 V _{aux}	Auxiliary input. Typical voltage 3.3 V.
2	+5.0 V _{in}	This is the input supply for the IC. Typical voltage 5.0 V. (Notes 1 and 2)
3	Gnd	Logic and power ground.
4	+3.3 V _{out}	3.3 V output provided to the application circuit (output current is sourced to this pin from the 5.0 V input.)
5	Drive out	This output drives a P-channel MOSFET with up to 2000 pF of "effective" gate capacitance. Recommended devices are the MMFT5P03HD and MTSF1P02HD. Drive out has active internal pull-up and pull-down circuitry to guarantee fast transitions.

MAXIMUM RATINGS (T_C = 25°C, unless otherwise noted)

Rating	Symbol	Value	Unit
+5.0 V _{in} Supply Voltage	V _{in}	7.0	Vdc
	V _{in}	-0.5 (Note 3)	Vdc
Operating Ambient Temperature	T _a	-5.0 to +85	°C
Operating Junction Temperature	T _J	- 5.0 to +150	°C
Lead Temperature (Soldering, 10 seconds)	T _L	300	°C
Storage Temperature	T _{stg}	- 55 to +150	°C
Package Thermal Resistance	R _{θJA} (Note 4)	65	°C/W

AC ELECTRICAL SPECIFICATIONS (Notes 5, 6, and 7)

Characteristic	Symbol	Min	Typ	Max	Unit
Drive High Delay (V _{in} ramping up) C _{drive} = 1.2 nF, measured from +5.0 V _{in} = V _{thresHi} to V _{Drive} = 2.0 V	t _{DH}	-	0.5	3.5	μS
Drive Low Delay (V _{in} ramping down) C _{drive} = 1.2 nF, measured from +5.0 V _{in} = V _{thresLo} to V _{Drive} = 2.0 V	t _{DL}	-	0.5	3.5	μS

1. See 5.0 V Detect Thresholds Diagram.
2. Recommended source impedance for 5.0 V supply: ≤ 0.12 Ω. This will ensure that I_o × R_{source} < V_{hyst}, thus avoiding driveout toggling during 5.0 V detect threshold transitions.
3. V_{in} should not be allowed to go negative relative to ground.
4. Mounted on recommended minimum PCB pad on FR4, 2-oz. copper circuit board.
5. AC specs are guaranteed by characterization, but not production tested after characterization.
6. See Figure 3. Application Block Diagram.
7. See Timing Diagram.

MC33566

DC ELECTRICAL CHARACTERISTICS (Note 8)

Characteristic	Symbol	Min	Typ	Max	Unit
+5.0 V _{in} Supply Voltage Range	+5.0 V _{in}	4.35	5.0	5.5	Vdc
Reverse Leakage Current from Output	I _{reverse}	–	–	25	μA
V _{aux} Quiescent Current	I _{qaux}	–	–	2.0	mA
+5.0 V _{in} Quiescent Current, Operating	I _{qvin}	–	–	10	mA
Load Capacitance (Note 9)	C _{load}	4.7	22	–	μF

REGULATOR OUTPUT

Output Voltage (4.35 V ≤ V _{in} ≤ 5.5 V, 0 mA ≤ I _o ≤ 400 mA) T _A = 25°C (T _J = –5°C to 150°C)	+3.3 V _{out}	3.267 3.234	3.30 3.30	3.333 3.366	Vdc
In-to-Out Voltage (3.9 V ≤ V _{in} ≤ 4.35 V, V _{aux} = 3.3 V)	V _d	3.0	–	–	Vdc
Voltage Out at Max Voltage In (V _{in} = 7.0 V)	V _{outmax}	3.1	3.3	3.5	Vdc
Line Regulation (I _o = 400 mA)	Linereg	–	–	0.4	%
Load Regulation (I _o = 0 to 400 mA)	Loadreg	–	–	0.8	%

5.0 V DETECT

Low Threshold Voltage (+5.0 V _{in} Falling, I _o = 400 mA)	V _{thresLo}	3.9	4.05	–	Vdc
High Threshold Voltage (+5.0 V _{in} Rising, I _o = 400 mA)	V _{thresHi}	–	4.2	4.35	Vdc
Hysteresis	V _{hyst}	0.05	–	–	Vdc

DRIVE OUTPUT

Output Peak Source Current (+5.0 V _{in} > V _{thresHi})	I _{peak}	15	–	–	mA
Output Peak Sink Current (+5.0 V _{in} < V _{thresLo})	I _{peak}	15	–	–	mA
Low Output Voltage (I _{oL} = 200 μA, V _{in} < V _{thresLo})	V _{oL}	–	100	200	mVdc
High Output Voltage (I _{oH} = 200 μA)	V _{oH}	3.4	–	–	Vdc

8. –5°C < T_a < 70°C, 4.35 V < V_{in} < 5.5 V, C_{load} ≥ 4.7 μF unless otherwise noted.

9. 4.7 μF minimum over temperature; 22 μF recommended; 500 mΩ ESR maximum.

MC33566

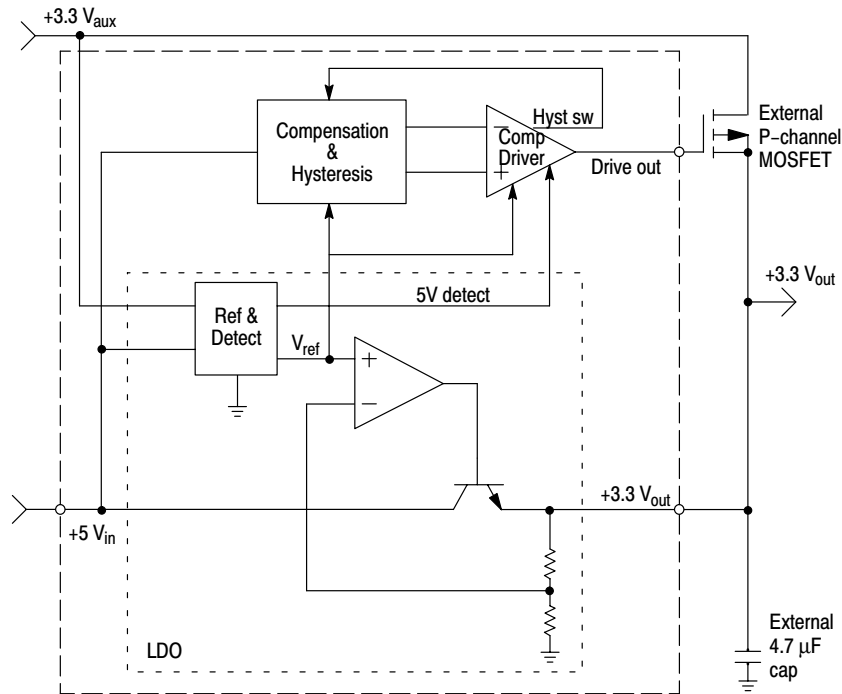

Figure 2. Functional Block Diagram

FUNCTIONAL DESCRIPTION

Input Blocking – The internal NPN pass transistor of the LDO regulator ensures that no significant reverse current will flow from +3.3 V_{out} back to the +5.0 V_{in} input when the 5.0 V input is not powered and the 3.3 V_{in} supply is present.

5.0 Volt Detect – Internal circuitry detects the presence of the 5.0 V input supply. When the 5.0 V supply drops below a given threshold, the +3.3 V_{in} bypass transistor (an external P-channel MOSFET) is enabled. The 5.0 V detect logic is active throughout the entire range of ramp-up from 0 to 5.5 V. Additionally, the drive out signal is never turned ON or OFF inappropriately during ramp-up of the +5.0 V_{in} supply. Also, +3.3 V_{out} never drops below 3.0 V while +5.0 V_{in} is above the 5.0 V detect minimum threshold.

Glitch-free Transfer – The design of the 5.0 V detect circuitry and drive out control circuitry guarantees that the +3.3 V_{out} will not exceed the output voltage specification listed in the table of DC Operating Specifications even with +5.0 V_{in} ramping up and down at the extremes of the slew rates in the table of AC Operating Specifications.

Offset Voltage Performance – To ensure performance when external offsets are present on the +5.0 V_{in} and +3.3 V_{in} power inputs, the device has been designed to be capable of operating with either one or both of these inputs rising from or falling to zero volts, or with offsets of 0.05 V to 0.9 V as the inputs ramp up and down.

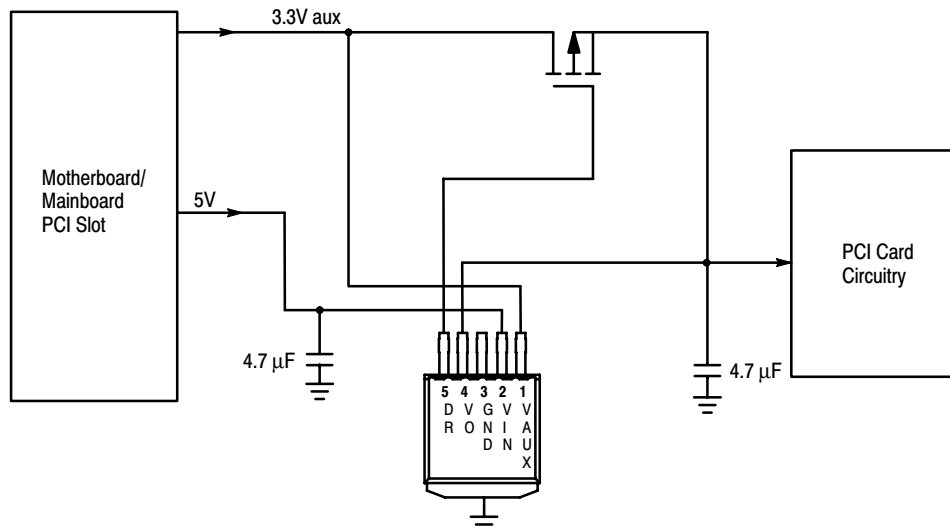
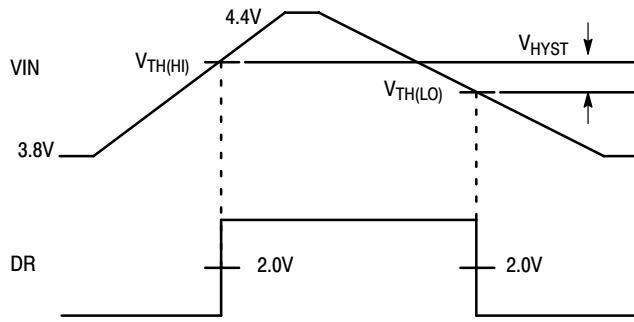

Figure 3. Application Block Diagram

MC33566



NOTE:
 (1) V_{in} rise and fall times (10% to 90%) to be $\geq 100 \mu s$.

Figure 4. 5.0 V Detect Thresholds Diagram

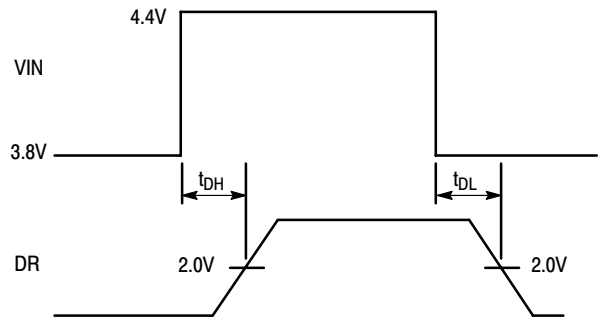

NOTE:
 (1) V_{in} rise and fall times (10% to 90%) to be $\leq 100 ns$.

Figure 5. Timing Diagram

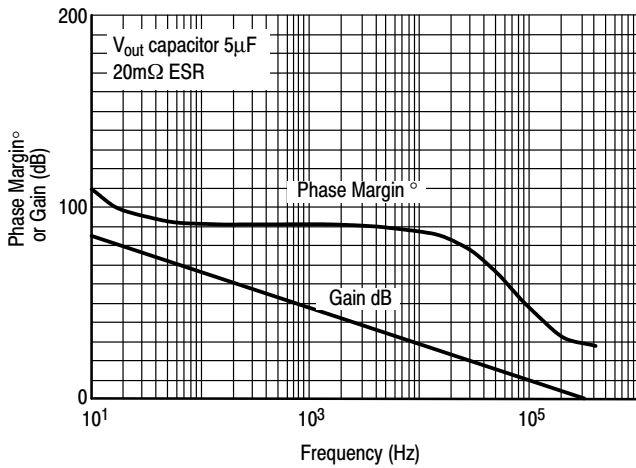

NOTE: V_{out} capacitor $\geq 4.7 \mu F$ over operating temperature range.
 Maximum ESR permissible = $500 m\Omega$ over operating temperature range.

Figure 6. Predicted Gain and Phase at Zero Load Current

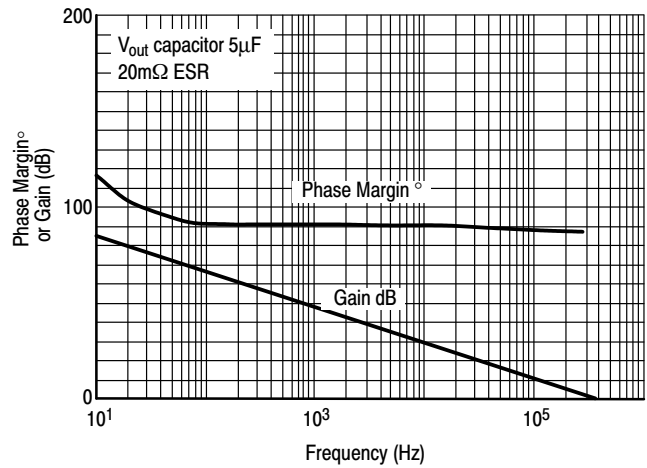
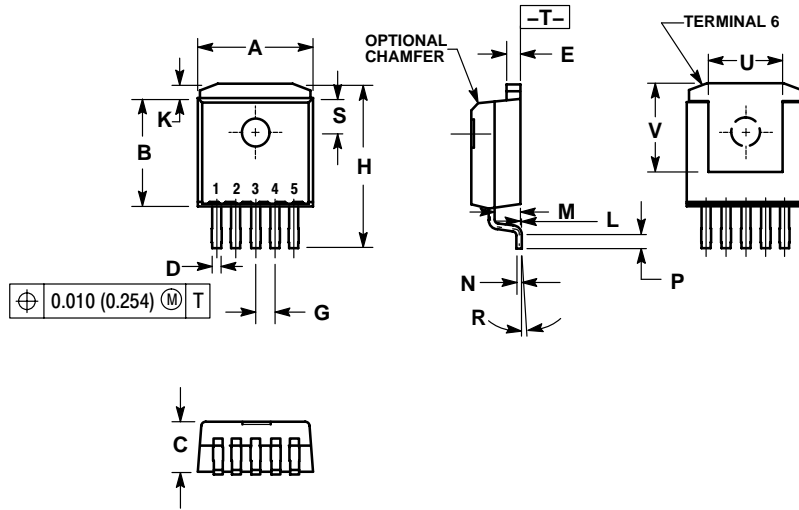

Figure 7. Predicted Gain and Phase at Full Load Current

MC33566

PACKAGE DIMENSIONS

(D²PAK)
D2T SUFFIX
PLASTIC PACKAGE
CASE 936A-02
ISSUE B



NOTES:

1. DIMENSIONING AND TOLERANCING PER ANSI Y14.5M, 1982.
2. CONTROLLING DIMENSION: INCH.
3. TAB CONTOUR OPTIONAL WITHIN DIMENSIONS A AND K.
4. DIMENSIONS U AND V ESTABLISH A MINIMUM MOUNTING SURFACE FOR TERMINAL 6.
5. DIMENSIONS A AND B DO NOT INCLUDE MOLD FLASH OR GATE PROTRUSIONS. MOLD FLASH AND GATE PROTRUSIONS NOT TO EXCEED 0.025 (0.635) MAXIMUM.

DIM	INCHES		MILLIMETERS	
	MIN	MAX	MIN	MAX
A	0.386	0.403	9.804	10.236
B	0.356	0.368	9.042	9.347
C	0.170	0.180	4.318	4.572
D	0.026	0.036	0.660	0.914
E	0.045	0.055	1.143	1.397
G	0.067 BSC		1.702 BSC	
H	0.539	0.579	13.691	14.707
K	0.050 REF		1.270 REF	
L	0.000	0.010	0.000	0.254
M	0.088	0.102	2.235	2.591
N	0.018	0.026	0.457	0.660
P	0.058	0.078	1.473	1.981
R	5° REF		5° REF	
S	0.116 REF		2.946 REF	
U	0.200 MIN		5.080 MIN	
V	0.250 MIN		6.350 MIN	

ON Semiconductor and are registered trademarks of Semiconductor Components Industries, LLC (SCILLC). SCILLC reserves the right to make changes without further notice to any products herein. SCILLC makes no warranty, representation or guarantee regarding the suitability of its products for any particular purpose, nor does SCILLC assume any liability arising out of the application or use of any product or circuit, and specifically disclaims any and all liability, including without limitation special, consequential or incidental damages. "Typical" parameters which may be provided in SCILLC data sheets and/or specifications can and do vary in different applications and actual performance may vary over time. All operating parameters, including "Typicals" must be validated for each customer application by customer's technical experts. SCILLC does not convey any license under its patent rights nor the rights of others. SCILLC products are not designed, intended, or authorized for use as components in systems intended for surgical implant into the body, or other applications intended to support or sustain life, or for any other application in which the failure of the SCILLC product could create a situation where personal injury or death may occur. Should Buyer purchase or use SCILLC products for any such unintended or unauthorized application, Buyer shall indemnify and hold SCILLC and its officers, employees, subsidiaries, affiliates, and distributors harmless against all claims, costs, damages, and expenses, and reasonable attorney fees arising out of, directly or indirectly, any claim of personal injury or death associated with such unintended or unauthorized use, even if such claim alleges that SCILLC was negligent regarding the design or manufacture of the part. SCILLC is an Equal Opportunity/Affirmative Action Employer. This literature is subject to all applicable copyright laws and is not for resale in any manner.

PUBLICATION ORDERING INFORMATION

LITERATURE FULFILLMENT:
Literature Distribution Center for ON Semiconductor
P.O. Box 5163, Denver, Colorado 80217 USA
Phone: 303-675-2175 or 800-344-3860 Toll Free USA/Canada
Fax: 303-675-2176 or 800-344-3867 Toll Free USA/Canada
Email: orderlit@onsemi.com

N. American Technical Support: 800-282-9855 Toll Free USA/Canada

Japan: ON Semiconductor, Japan Customer Focus Center
2-9-1 Kamimeguro, Meguro-ku, Tokyo, Japan 153-0051
Phone: 81-3-5773-3850

ON Semiconductor Website: <http://onsemi.com>

Order Literature: <http://www.onsemi.com/litorder>

For additional information, please contact your local Sales Representative.