

PLEASE CHECK WWW.MOLEX.COM FOR LATEST PART INFORMATION

Part Number: [0194170048](#)
Status: **Active**
Overview: [mx150l sealed connector system](#)
Description: MX150L™ Male Terminal for 18-22 AWG Wire, Length 25.40mm (1.00")

Documents:

[Drawing \(PDF\)](#) [RoHS Certificate of Compliance \(PDF\)](#)
[Product Specification PS-19417-001 \(PDF\)](#)

Agency Certification

CSA LR18689
 UL E152602

General

Product Family Crimp Terminals
 Series [19417](#)
 Comments UL E152602|Standard Length
 Crimp Quality Equipment Yes
 MolexKits Yes
 Overview [mx150l sealed connector system](#)
 Product Literature Order No 987650-2181
 Product Name MX150L™

Physical

Durability (mating cycles max) 25
 Gender Male
 Material - Metal High Performance Alloy (HPA)
 Material - Plating Mating Tin
 Material - Plating Termination Tin
 Packaging Type Bag
 Plating min: Mating (µin) 75.20
 Plating min: Mating (µm) 1.880
 Plating min: Termination (µin) 75.20
 Plating min: Termination (µm) 1.88
 Termination Interface: Style Crimp or Compression
 Wire Insulation Diameter 2.36-2.74mm (.093-.108")
 Wire Size AWG 18, 20, 22
 Wire Size mm² N/A

Material Info

Reference - Drawing Numbers

Packaging Specification PK-19417-002
 Product Specification PS-19417-001
 Sales Drawing SD-19417-001

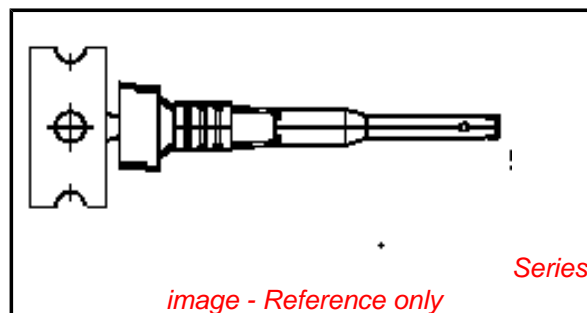

EU RoHS

ELV and RoHS Compliant
REACH SVHC
Contains SVHC: No
Halogen-Free Status

China RoHS



Need more information on product environmental compliance?

Email productcompliance@molex.com
 For a multiple part number RoHS Certificate of Compliance, [click here](#)

Please visit the [Contact Us](#) section for any non-product compliance questions.

Search Parts in this Series

[19417Series](#)

Mates With

[19420](#)

Use With

[19419](#) , [19429](#)

Application Tooling | FAQ

Tooling specifications and manuals are found by selecting the products below. Crimp Height Specifications are then contained in the Application Tooling Specification document.

Global

Description	Product #
Manual Extraction Tool	0638131500
Hand Crimp Tool	0638114400
Hand Crimp Tool	0638117600

12	11	10	9	8	7	6	5	4	3	2	19417
STRIP MATERIAL NUMBER	LOOSE PIECE MATERIAL NUMBER	AWG SIZE	FINISH		DIM. "A"	DIM. "B"	DIM. "C"	DIM. "D"	DIM. "E"	DIM. "F"	
194170011	194170047	16-14	PREPLATED TIN 75µ MIN. THICK OVER NICKEL FLASH		.230/5.84	.182/4.62	.141/3.58	.155/3.94	.591/15.00	1.000/25.40	
194170024	194170048	22-18	PREPLATED TIN 75µ MIN. THICK OVER NICKEL FLASH		.181/4.60	.143/3.63	.108/2.74	.112/2.84	.591/15.00	1.000/25.40	
194170025	194170049	16-14	SELECT HARD GOLD 30µ MIN. THICK WITH SELECT TIN 100µ MIN. THICK OVER NICKEL 50µ MIN. THICK OVERALL		.230/5.84	.182/4.62	.141/3.58	.155/3.94	.591/15.00	1.000/25.40	
194170026	194170050	22-18	SELECT HARD GOLD 30µ MIN. THICK WITH SELECT TIN 100µ MIN. THICK OVER NICKEL 50µ MIN. THICK OVERALL		.181/4.60	.143/3.63	.108/2.74	.112/2.84	.591/15.00	1.000/25.40	
194170027	194170051	16-14	PREPLATED TIN 75µ MIN. THICK OVER NICKEL FLASH		.230/5.84	.182/4.62	.141/3.58	.155/3.94	.621/15.77	1.030/26.16	
194170028	194170052	22-18	PREPLATED TIN 75µ MIN. THICK OVER NICKEL FLASH		.181/4.60	.143/3.63	.108/2.74	.112/2.84	.621/15.77	1.030/26.16	
194170029	194170053	16-14	SELECT HARD GOLD 30µ MIN. THICK WITH SELECT TIN 100µ MIN. THICK OVER NICKEL 50µ MIN. THICK OVERALL		.230/5.84	.182/4.62	.141/3.58	.155/3.94	.621/15.77	1.030/26.16	
194170030	194170054	22-18	SELECT HARD GOLD 30µ MIN. THICK WITH SELECT TIN 100µ MIN. THICK OVER NICKEL 50µ MIN. THICK OVERALL		.181/4.60	.143/3.63	.108/2.74	.112/2.84	.621/15.77	1.030/26.16	

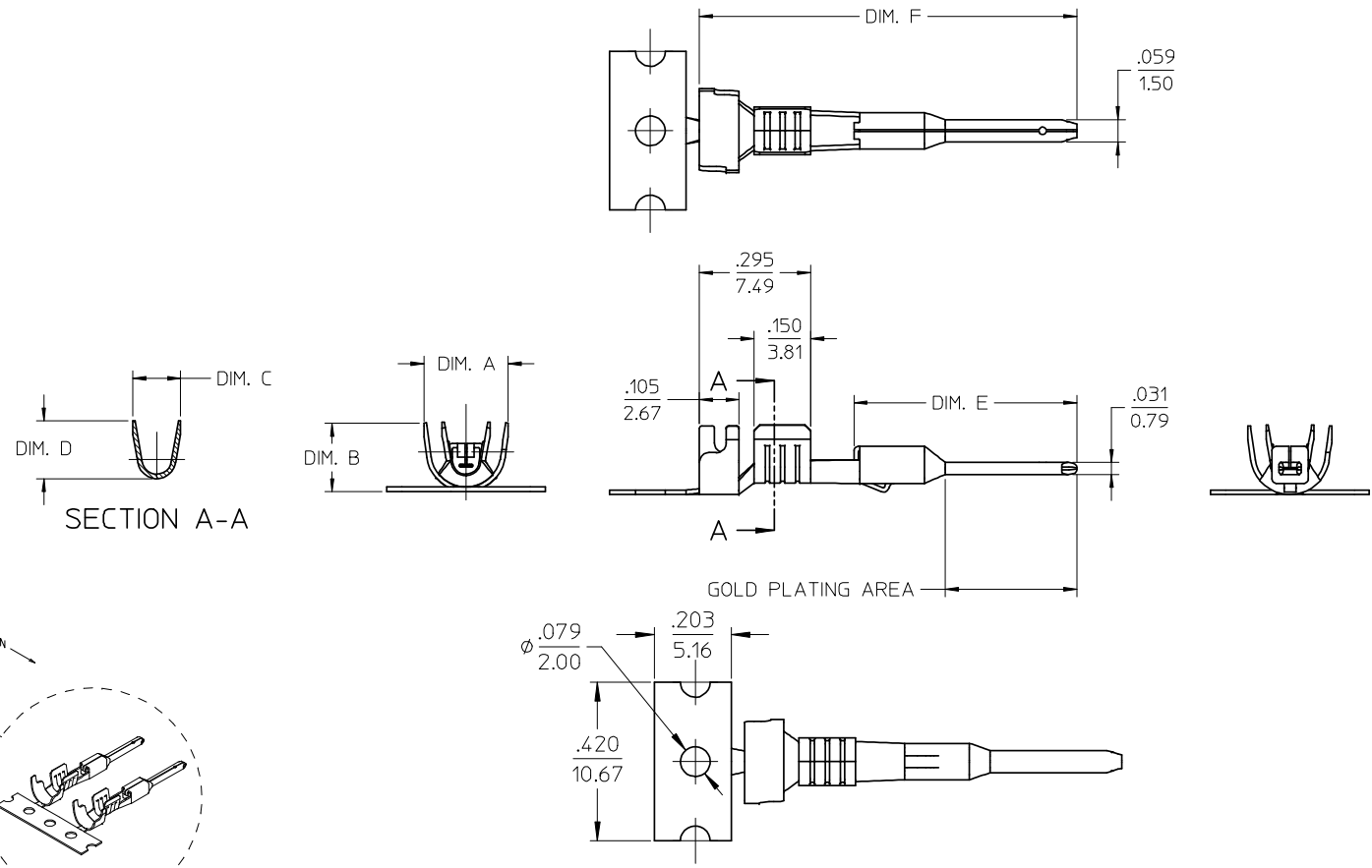
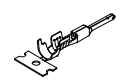

- NOTES:
1. MATERIAL: COPPER ALLOY .012/0.30 THK.
 2. FINISH: SEE CHART
 3. TERMINAL FOR USE WITH 19419-**** PLUG HOUSING ASSEMBLY.
 4. STRIP TERMINALS ARE REELED AS SHOWN ABOVE ON 24" REELS. 4000 PARTS PER REEL.
 5. LOOSE TERMINALS ARE BULK PACKAGED IN QUANTITIES OF 400.
 6. APPLICATION TOOLING AND CRIMP SPECIFICATIONS: 63865-6000 (14-16 AWG), 63865-6100 (18-22 AWG), 63811-3900 (HAND TOOL).

EC NO: ETC2004-0249 DRWN: JPAWLICK 2004/06/25 CHKD: JPAWLICK 2004/06/25 APPR: RDEROSS 2004/06/25	QUALITY SYMBOLS ▽ - 0 ▽ C - 0	GENERAL TOLERANCES (UNLESS SPECIFIED)		SCALE 4:1	DESIGN UNITS INCH	THIRD ANGLE PROJECTION	REVISE ON CAD ONLY
				DIMENSION STYLE IN/MM		TITLE	
		4 PLACES ± --- ± ---		DRAWN BY JPAWLICK DATE 05/05/03		MALE PIN TERMINAL, 22-18 & 16-14 AWG, .059/1.50 X .031/0.79	
		3 PLACES ± --- ± .010		CHECKED BY JPAWLICK DATE 05/05/02		MOLEX INCORPORATED	
		2 PLACES ± 0.25 ± .02		APPROVED BY RDEROSS DATE 05/05/03	MATERIAL NO. SEE CHART	DOCUMENT NO. SD-19417-001	SHEET NO. 1 OF 1
		1 PLACE ± 0.5 ± ---		THIS DRAWING CONTAINS INFORMATION THAT IS PROPRIETARY TO MOLEX INCORPORATED AND SHOULD NOT BE USED WITHOUT WRITTEN PERMISSION			
DRAFT WHERE APPLICABLE MUST REMAIN WITHIN DIMENSIONS							