

# MAXIM

## 24-Output PWM LED Drivers for Message Boards

MAX6974/MAX6975

### General Description

The MAX6974/MAX6975 precision current-sinking, 24-output PWM LED drivers drive red, green, and blue LEDs for full-color graphic message boards and video displays. Each output has an individual 12-bit (MAX6974) or 14-bit (MAX6975) PWM-intensity (hue) control and 7-bit (MAX6974) or 5-bit (MAX6975) global PWM intensity (luminance) control. The MAX6974/MAX6975 feature a high-speed, fully buffered cascadable serial interface, open-circuit LED fault detection circuitry, as well as a watchdog timer.

The driver has three banks of eight outputs, with each bank intended to drive a different color in RGB applications. The full-scale current for each bank of eight outputs is adjustable from 6mA to 30mA in 256 steps (0.3125% per step) to calibrate each color.

The MAX6974/MAX6975 can optionally multiplex by using outputs MUX0 and MUX1, which each drive an external pnp transistor. Multiplexing doubles the MAX6974/MAX6975 drive capability to 48 LEDs.

The MAX6974/MAX6975 operate from a 3.0V to 3.6V power supply. The LED power supply can range from 3V to 7V. The LED drivers require only 0.8V headroom above the LEDs' forward-voltage drop. Using a separate LED supply voltage for each LED minimizes power consumption.

The serial interface uses differential signaling for the high-speed clock and data signals to reduce EMI and improve signal integrity. The MAX6974/MAX6975 buffer all interface signals to simplify cascading devices in modules that use a large number of drivers.

An internal watchdog timer, when enabled, automatically clears the pixel-data registers and blanks the display if any of the signal inputs fail to toggle within 40ms.

The MAX6974/MAX6975 are available in 40-pin TQFN packages and operate over the -40°C to +125°C temperature range.

Refer to the MAX6972/MAX6973 data sheet for a 16-output, 11mA to 55mA software-compatible device.

*EZCascade is a trademark of Maxim Integrated Products, Inc.*

### Applications

- LED Video Display Panels
- LED Message Boards
- Variable Message Signs (VMS)
- Signs
- Graphic Panels

*Typical Operating Circuit appears at the end of data sheet.*

**MAXIM**

### Features

- ◆ 24 LED Current Sink Outputs (Three Banks of Eight Outputs)
- ◆ 48 LED Drive Option When Multiplexing
- ◆ 33MHz Clock Supports Up to 63 Frames per Second of Video
- ◆ Constant Output Current Calibration from 6mA to 30mA in 256 Steps
- ◆ EZCascade™ Interface Simplifies Multiple Driver Cascading Without External Buffers
- ◆ 12-Bit or 14-Bit Individual PWM LED Intensity Controls
- ◆ 7-Bit or 5-Bit Panel PWM-Intensity Control
- ◆ +3V to +7V LED Power Supply
- ◆ +3.0V to +3.6V Logic Supply
- ◆ Open-Circuit LED Fault Detection
- ◆ Optional Watchdog Timer Blanks Display if Interface Fails
- ◆ Standard -40°C to +125°C Operating Temperature Range

### Ordering Information

PART	TEMP RANGE	PIN-PACKAGE	PKG CODE
MAX6974ATL+	-40°C to +125°C	40 TQFN-EP*	T4066-3
MAX6975ATL+	-40°C to +125°C	40 TQFN-EP*	T4066-3

\*EP = Exposed pad.

+ Denotes lead-free package.

### Pin Configuration

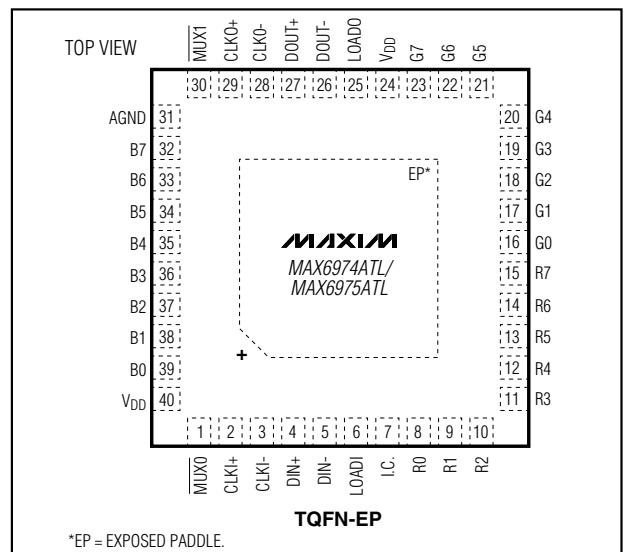

Maxim Integrated Products 1

**For pricing delivery, and ordering information please contact Maxim/Dallas Direct! at 1-888-629-4642, or visit Maxim's website at www.maxim-ic.com.**

# 24-Output PWM LED Drivers for Message Boards

## ABSOLUTE MAXIMUM RATINGS

(All voltages with respect to GND.)

V <sub>DD</sub> .....	-0.3V to +4.0V
R0–R7, G0–G7, B0–B7, MUX0, and MUX1 .....	-0.3V to +8.0V
All Other Pins .....	-0.3V to (V <sub>DD</sub> + 0.3V)
Continuous Power Dissipation (T <sub>A</sub> = +70°C)	
40-Pin TQFN (derate 37mW/°C over +70°C) .....	2963mW

Operating Temperature Range .....	-40°C to +125°C
Junction Temperature .....	+150°C
Storage Temperature Range .....	-65°C to +150°C
Lead Temperature (soldering, 10s) .....	+300°C

Stresses beyond those listed under "Absolute Maximum Ratings" may cause permanent damage to the device. These are stress ratings only, and functional operation of the device at these or any other conditions beyond those indicated in the operational sections of the specifications is not implied. Exposure to absolute maximum rating conditions for extended periods may affect device reliability.

## ELECTRICAL CHARACTERISTICS

(V<sub>DD</sub> = 3.0V to 3.6V, T<sub>A</sub> = T<sub>MIN</sub> to T<sub>MAX</sub>, unless otherwise noted. Typical values are at V<sub>DD</sub> = 3.3V, T<sub>A</sub> = +85°C.) (Note 1)

PARAMETER	SYMBOL	CONDITIONS	MIN	TYP	MAX	UNITS
Operating Supply Voltage	V <sub>DD</sub>		3.0		3.6	V
LEDs Anode Voltage (R0–R7, G0–G7, B0–B7, MUX0, and MUX1)	V <sub>O</sub>				7	V
Supply Current	I <sub>DD</sub>	f <sub>CLKI</sub> = 0Hz; CLKO <sub>_</sub> , DOUT <sub>_</sub> loaded 200Ω; calibration DACs set to 0x01		28	52	mA
		f <sub>CLKI</sub> = 0Hz; CLKO <sub>_</sub> , DOUT <sub>_</sub> loaded 200Ω; calibration DACs set to 0xFF		51	72	
		f <sub>CLKI</sub> = 32MHz; CLKO <sub>_</sub> , DOUT <sub>_</sub> loaded 200Ω; calibration DACs set to 0xFF		54	77	
Input High Voltage LOAD <sub>I</sub>	V <sub>IHC</sub>		0.7 x V <sub>DD</sub>			V
Input Low Voltage LOAD <sub>I</sub>	V <sub>ILC</sub>				0.3 x V <sub>DD</sub>	V
Differential Input Voltage Range CLKI <sub>_</sub> , DIN <sub>_</sub>	V <sub>ID</sub>		±0.15		±1.20	V
Common-Mode Input Voltage CLKI <sub>_</sub> , DIN <sub>_</sub>	V <sub>CM</sub>		V <sub>ID</sub> / 2		2.4	V
Differential Input High Threshold	V <sub>DIFFTH</sub>			8	100	mV
Differential Input Low Threshold	V <sub>DIFFTL</sub>		-100	-8		mV
Differential Output Voltage CLKO <sub>_</sub> , DOUT <sub>_</sub>	V <sub>OD</sub>	Termination 200Ω at receiver <sub>+</sub> and <sub>-</sub> inputs	±190		±550	mV
Differential Output Offset CLKO <sub>_</sub> , DOUT <sub>_</sub>	V <sub>OS</sub>	Termination 200Ω at receiver <sub>+</sub> and <sub>-</sub> inputs	1.125	1.25	1.375	V
Input Leakage Current CLKI <sub>_</sub> , DIN <sub>_</sub> , LOAD <sub>I</sub>	I <sub>IH</sub> , I <sub>IL</sub>		-1		+1	μA
Input Capacitance CLKI <sub>_</sub> , DIN <sub>_</sub> , LOAD <sub>I</sub>				10		pF
Output Low Voltage LOAD <sub>O</sub>	V <sub>OLC</sub>	I <sub>SINK</sub> = 5mA		0.05	0.25	V
Output High Voltage LOAD <sub>O</sub>	V <sub>OHC</sub>	I <sub>SOURCE</sub> = 5mA	V <sub>DD</sub> - 0.5	V <sub>DD</sub> - 0.2		V

# 24-Output PWM LED Drivers for Message Boards

MAX6974/MAX6975

## ELECTRICAL CHARACTERISTICS (continued)

(V<sub>DD</sub> = 3.0V to 3.6V, T<sub>A</sub> = T<sub>MIN</sub> to T<sub>MAX</sub>, unless otherwise noted. Typical values are at V<sub>DD</sub> = 3.3V, T<sub>A</sub> = +85°C.) (Note 1)

PARAMETER	SYMBOL	CONDITIONS	MIN	TYP	MAX	UNITS	
Output Slew Time LOADO		20% to 80%, 80% to 20%, load = 10pF		3		ns	
Output Low Voltage MUX <sub>-</sub>	V <sub>OLM</sub>	I <sub>SINK</sub> = 40mA			0.4	V	
Open-Circuit Detection	V <sub>OCD</sub>			200		mV	
Output Voltage Slew Time R0-R7, G0-G7, B0-B7		80% to 20%, load = 50pF, calibration DACs set to 0xFF			100	ns	
Full-Scale Port Output Current R0-R7, G0-G7, B0-B7	I <sub>SINKFS</sub>	V <sub>DD</sub> = 3.3V, V <sub>O</sub> = 1.2V, calibration DACs set to 0xFF	T <sub>A</sub> = +85°C	28	30	32	mA
			T <sub>A</sub> = T <sub>MIN</sub> to T <sub>MAX</sub>	26		34	
Port-to-Port Current Matching R0-R7, G0-G7, B0-B7	ΔI <sub>SINK</sub>	V <sub>DD</sub> = 3.3V, V <sub>O</sub> = 1.2V, calibration DACs set to 0xFF I <sub>SINK</sub> = 30mA (Note 2)	T <sub>A</sub> = +125°C (Note 3)		±0.7	2.7	%
			T <sub>A</sub> = +85°C		±0.7	2	
			T <sub>A</sub> = -40°C (Note 3)		±0.9	3.3	
Output Load Regulation	ΔI <sub>OLR</sub>	V <sub>DD</sub> = 3.3V, V <sub>O</sub> = 1.2V to 3.0V, calibration DACs set to 0x80, I <sub>SINK</sub> = 18mA	T <sub>A</sub> = +85°C		0.3	1.15	mA/V
			T <sub>A</sub> = T <sub>MIN</sub> to T <sub>MAX</sub>			1.5	
Output Power-Supply Rejection	ΔI <sub>OPSR</sub>	V <sub>DD</sub> = 3.0V to 3.6V, V <sub>O</sub> = 1.2V, calibration DACs set to 0x80, I <sub>SINK</sub> = 18mA	T <sub>A</sub> = +85°C		0.6	1.7	mA/V
			T <sub>A</sub> = T <sub>MIN</sub> to T <sub>MAX</sub>			2.0	

## TIMING CHARACTERISTICS

(V<sub>DD</sub> = 3.0V to 3.6V, T<sub>A</sub> = T<sub>MIN</sub> to T<sub>MAX</sub>, unless otherwise noted. Typical values are at 3.3V, T<sub>A</sub> = +85°C.) (Note 1)

PARAMETER	SYMBOL	CONDITIONS	MIN	TYP	MAX	UNITS
CLKI_ Input Frequency	f <sub>CLKI</sub>				33	MHz
CLKI_ Duty Cycle			40		60	%
CLKO_ Output Delay	t <sub>PD-CLKO</sub>				16	ns
DIN_ Setup Time	t <sub>SU-DIN</sub>		0.5			ns
DIN_ Hold Time	t <sub>HD-DIN</sub>		5			ns
DOUT_ Output Delay	t <sub>PD-DOUT</sub>				15	ns
LOADO Output Delay	t <sub>PD-LOADO</sub>				18	ns
LOADI Hold Time	t <sub>HD-LOADI</sub>		8			ns
Watchdog Period		When enabled	40	125	300	ms

**Note 1:** All parameters tested at T<sub>A</sub> = +85°C. Specifications over temperature are guaranteed by design.

**Note 2:** Specification limits apply to devices at the same T<sub>A</sub> for T<sub>A</sub> = T<sub>MIN</sub> to T<sub>MAX</sub>.

**Note 3:** Guaranteed by design.

# 24-Output PWM LED Drivers for Message Boards

## Typical Operating Characteristics

( $V_{DD} = 3.3V$ ,  $T_A = +25^\circ C$ , unless otherwise noted.)

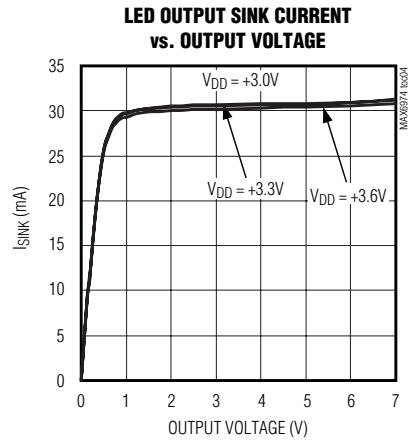
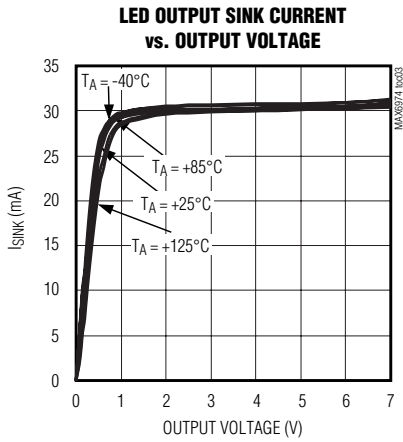
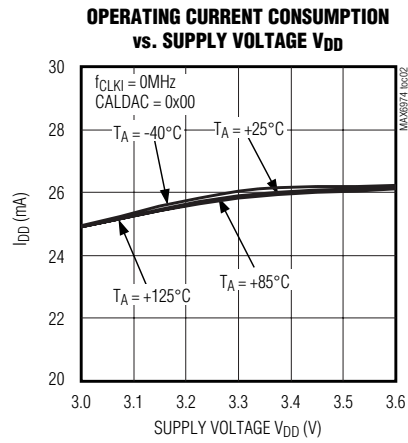
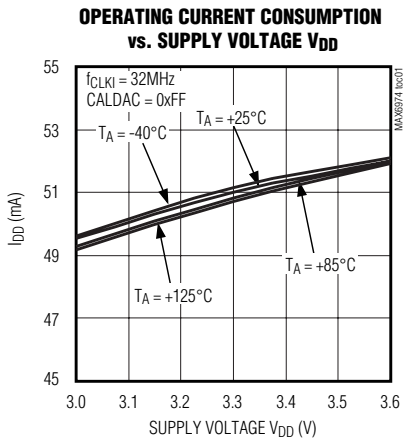

## 24-Output PWM LED Drivers for Message Boards

### Pin Description

PIN	NAME	FUNCTION
1	$\overline{\text{MUX0}}$	Multiplex 0 Active-Low, Open-Drain Output. Use $\overline{\text{MUX0}}$ to drive a pnp transistor.
2	CLKI+	PWM and Serial-Interface Noninverting Clock LVDS Input
3	CLKI-	PWM and Serial-Interface Inverting Clock LVDS Input
4	DIN+	Serial-Interface Noninverting Data LVDS Input
5	DIN-	Serial-Interface Inverting Data LVDS Input
6	LOADI	Serial-Interface Load CMOS Input
7	I.C.	Internally Connected. Connect to GND.
8–15	R0–R7	Red LED Drive Outputs. R0 to R7 are open-drain, constant-current sinks.
16–23	G0–G7	Green LED Drive Outputs. G0–G7 are open-drain, constant-current sinks.
24, 40	V <sub>DD</sub>	Positive Supply Voltage. Bypass V <sub>DD</sub> to GND with a 0.1 $\mu$ F ceramic capacitor.
25	LOADO	Serial-Interface Load CMOS Output
26	DOUT-	Serial-Interface Inverting Data LVDS Output
27	DOUT+	Serial-Interface Noninverting Data LVDS Output
28	CLKO-	PWM and Serial-Interface Inverting Clock LVDS Output
29	CLKO+	PWM and Serial-Interface Noninverting Clock LVDS Output
30	$\overline{\text{MUX1}}$	Multiplex 1 Active-Low, Open-Drain Output. Use $\overline{\text{MUX1}}$ to drive a pnp transistor.
31	AGND	Analog Ground. Connect to GND.
32–39	B7–B0	Blue LED Drive Outputs. B0 to B7 are open-drain, constant-current sinks.
EP	GND	Power Ground. Exposed pad on package underside must be connected to GND.

**MAX6974/MAX6975**

# 24-Output PWM LED Drivers for Message Boards

MAX6974 Block Diagram

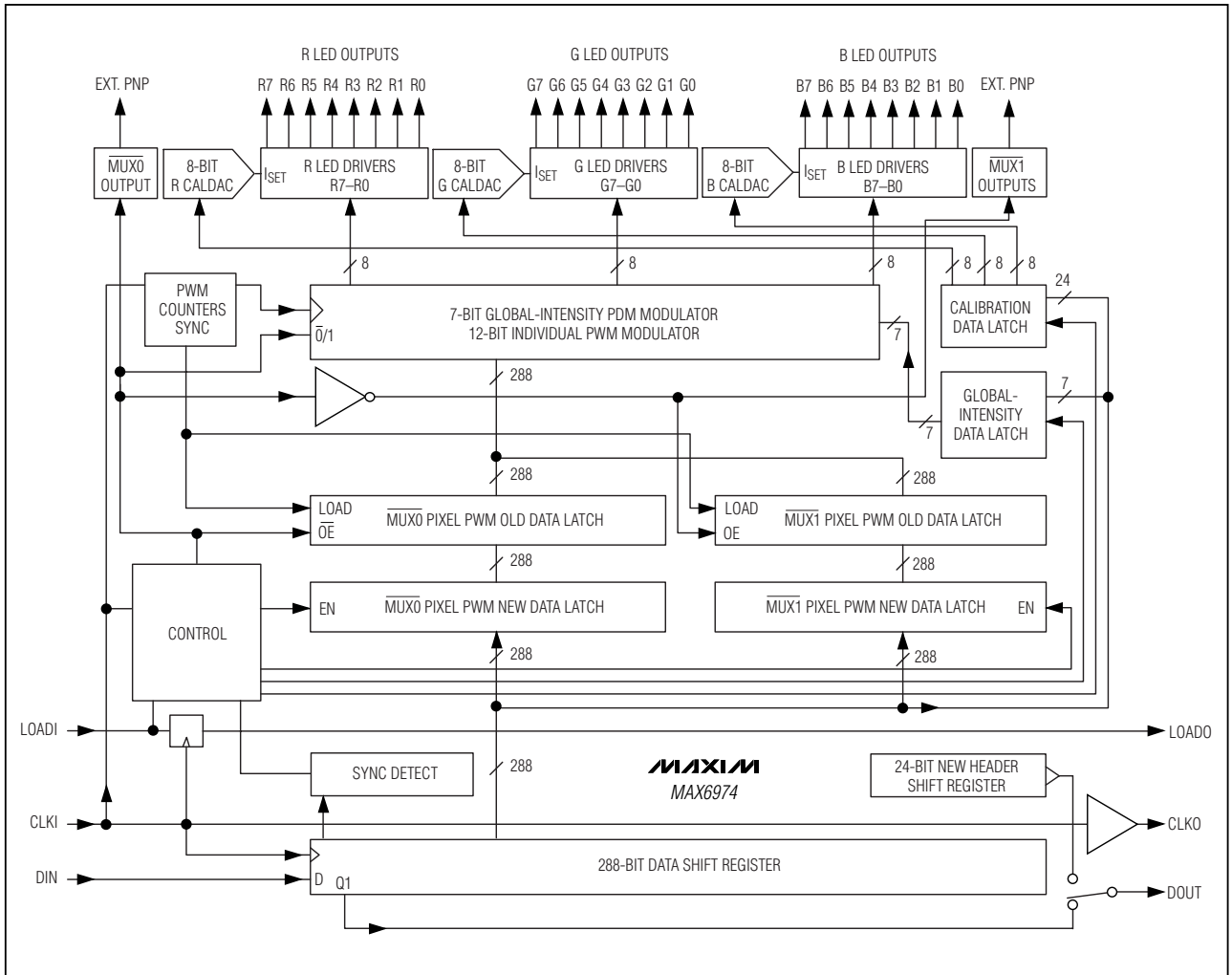

# 24-Output PWM LED Drivers for Message Boards

MAX6975 Block Diagram

MAX6974/MAX6975

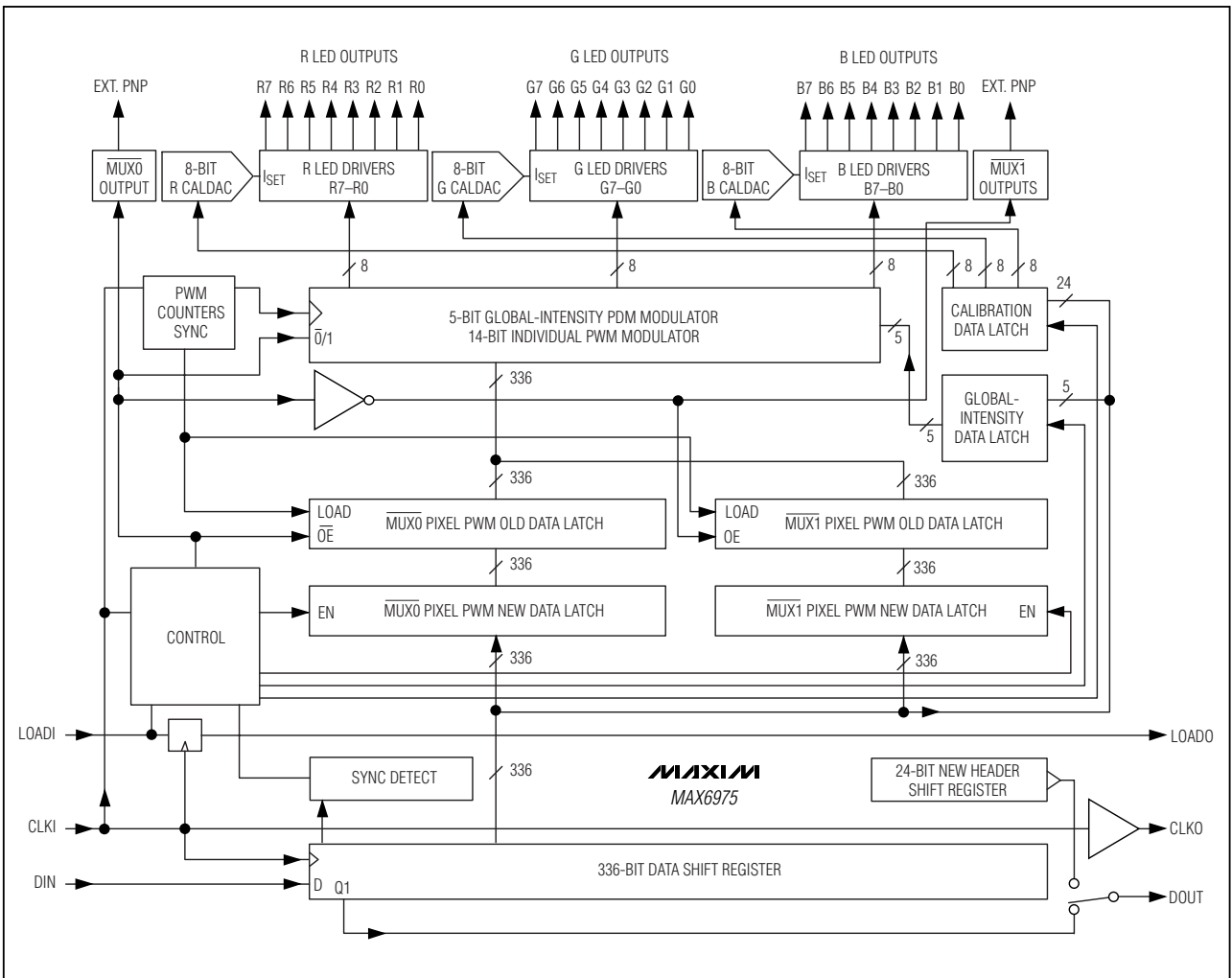

# 24-Output PWM LED Drivers for Message Boards

## Detailed Description

The MAX6974/MAX6975 drive 24 nonmultiplexed LEDs or 48 multiplexed LEDs for various indoor and outdoor display applications. The EZCascade serial interface enables large multidriver display panels to be constructed with interconnected MAX6974/MAX6975 devices (see Figure 1).

The drivers provide 12-bit (MAX6974) or 14-bit (MAX6975) individual PWM steps for each LED output. Four to seven global-intensity bits provide additional pulse-density modulation (PDM) intensity control (see Table 1). The MAX6974/MAX6975 provide 19 bits of total current/intensity control range per color per pixel, or 18 bits if multiplexing. The total PWM dynamic range encompasses gamma correction and, if desired, individual LED calibration.

LED outputs are grouped in ports (R, G, and B) with eight LED outputs per port. Each port features its own current calibration control DAC (CALDAC) with 0.31% resolution to set the current. The MAX6974/MAX6975 current calibration feature allows unmatched LEDs from different lots and manufacturers to be color matched.

## Power-Up

On power-up, the MAX6974/MAX6975 set the calibration current to the minimum current for all LED outputs and clear the global-intensity PDM data, individual-intensity PWM data, and the timing counters. The display remains blank after CLKI starts running. The watchdog function is inactive after power-up.

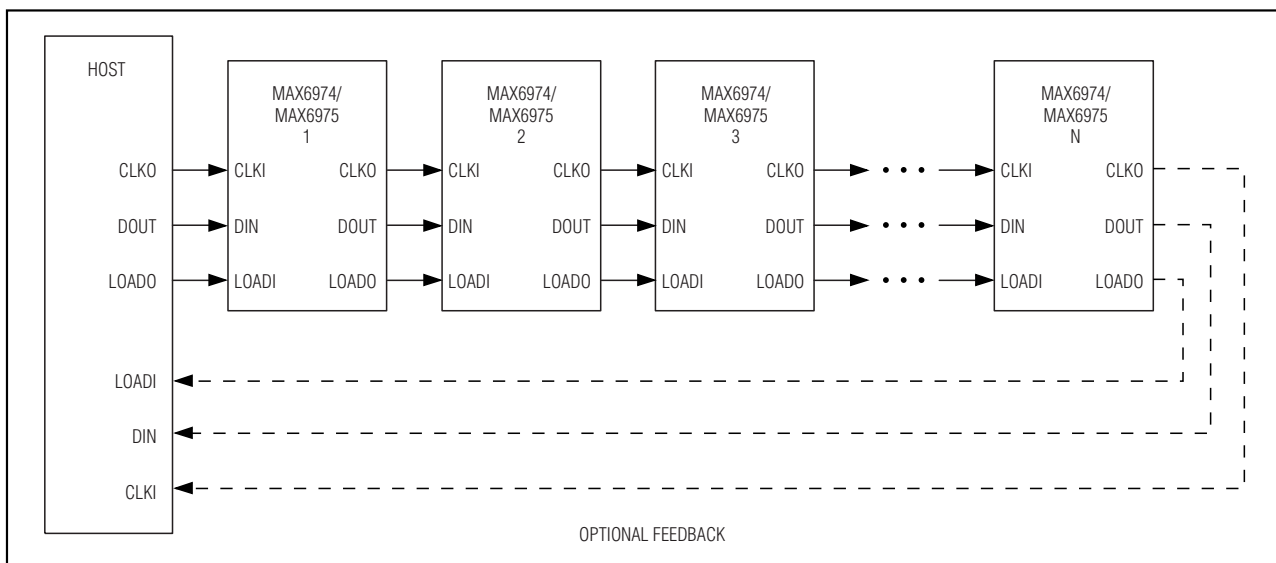

Figure 1. Generic Cascaded Connection Scheme

Table 1. Comparison of MAX6974/MAX6975

PART	LED DRIVE OUTPUTS	LED DRIVE CURRENT	CALIBRATION DAC RANGE	GLOBAL PDM		INDIVIDUAL PWM
				DIRECT	MULTIPLEXED	
MAX6974	24 (7V rated)	30mA	6mA to 30mA	7 bits	6 bits	12 bits
MAX6975				5 bits	4 bits	14 bits
				3 bits	2 bits	



# 24-Output PWM LED Drivers for Message Boards

## LED-Intensity Control

The MAX6974/MAX6975 provide three levels of output current control for LED drive: calibration DACs (CALDACs), global-intensity control, and individual-intensity control. The CALDACs set the port output current levels, while the global-intensity and individual-intensity controls modulate the output current on/off times, providing a fine-resolution control of average output currents (see Figure 2). The individual-intensity control operates on each output independently to set each individual LED intensity level. The global-intensity controls modulate MAX6974/MAX6975 outputs simultaneously for a uniform brightness control without affecting color. Using a fixed output current level that is modulated only by on/off control leaves the LED color unaffected while precisely controlling intensity. Finally, all outputs can be turned on and off simultaneously by setting or clearing configuration bit D3 (PWM-ON).

## Calibration DACs

The 8-bit R, G, and B CALDACs set the output current level for all eight outputs in the R, G, and B ports, respectively (see the *MAX6974/MAX6975 Block Diagrams*). The R CALDAC, G CALDAC, and B CALDAC range from a low of 6mA (0x00) to a maximum of 30mA (0xFF), providing 94 $\mu$ A/step of current trimming. The CALDACs are loaded by the serial interface using command 01 (see Table 4). The B CALDAC data is loaded first, followed by the G CALDAC data, and then the R CALDAC data (see the *Serial Interface* section). The loaded data takes effect immediately.

## Global-Intensity Control

The MAX6974/MAX6975 adjust global and individual intensities over a time period called a frame. One frame requires  $2^{19}$  (524,288) periods of CLKI and corresponds to one video-frame time. Video frames generally contain consecutive images displayed rapidly to yield a motion picture display. Running the MAX6974/MAX6975 at  $f_{CLKI} = 31.5\text{MHz}$  allows a video-frame update rate of 60fps for full-motion video (see the *MAX6974 Video-Frame Timing* and *MAX6975 Video-Frame Timing* sections).

The MAX6974/MAX6975 further divide frames into subframes to allow a unique combination of global- and individual-intensity controls. The number of subframes is equal to the number of global-intensity control steps. The MAX6974 uses 128 subframes per frame in nonmultiplexed mode (corresponding to 7-bit global-intensity PDM control) and 64 subframes in multiplexed mode (corresponding to 6-bit global-intensity PDM control). The MAX6975 features 5-, 4-, 3-, and 2-bit global-intensity control to yield 32, 16, 8, and 4 subframes per frame, respectively.

The MAX6974/MAX6975 control global intensity by driving subframes on and off. When a subframe is on, it allows the individual PWM intensity control to be driven on the outputs. Subframes that are off do not have any PWM modulation on the outputs.

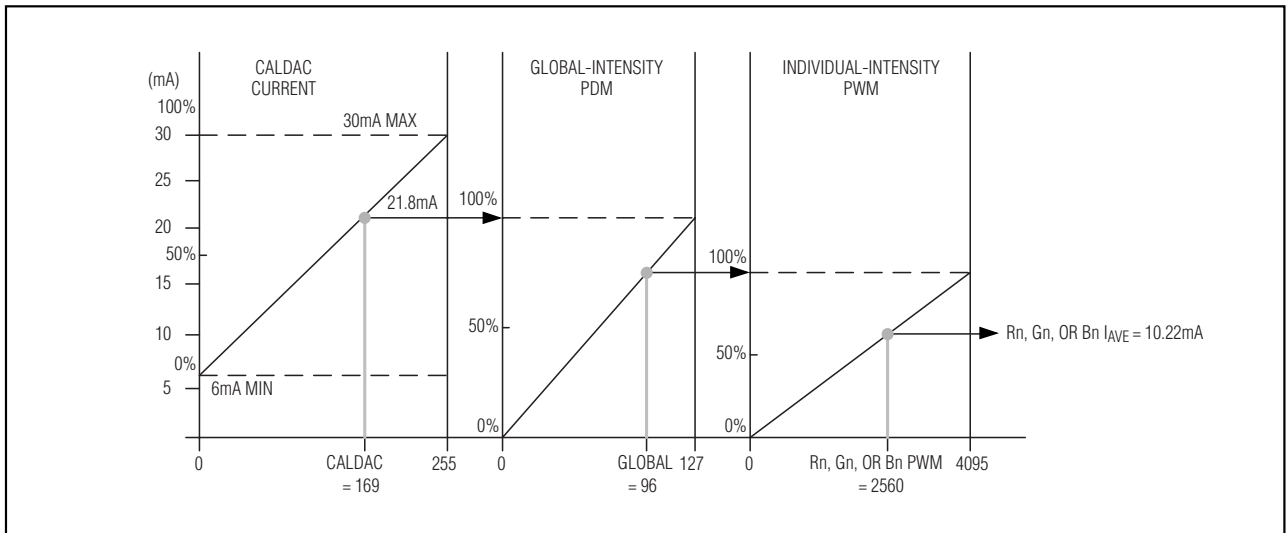

Figure 2. Relationship Among the CALDACs, Global-Intensity, and Individual-Intensity PWM Controls

# 24-Output PWM LED Drivers for Message Boards

## Individual PWM Control

The MAX6974/MAX6975 further modulate the time that each subframe is ON by a pulse-width modulation (PWM) value. Each output current driver in the R, G, and B ports has a unique 12-bit (MAX6974) or 14-bit (MAX6975) PWM control value providing fine resolution adjustment of average current output. Each bit time of the PWM corresponds to one period of CLKI (TCLKI). The PWM setting determines the amount of time, out of the total period, that the output is on. The subframes have PWM off-zones at the start (tSPWM) and end (tEPWM) of the PWM period (see Figure 3). The subframe period and PWM off zones are shown in Table 2 for each device.

**Table 2. Subframe and PWM Timing**

PART	SUBFRAME (TCLKI)	tSPWM (TCLKI)	tEPWM (TCLKI)	tEMUX (TCLKI)
MAX6974	4096	16	16	16
MAX6975	16,384	32	32	32

The MAX6974 subdivides each subframe by 4096 (12-bit) PWM steps and has 16 cycle off zones, leaving an active PWM region of 4064 PWM steps ranging from 16 to 4079. The MAX6975 subdivides each subframe by 16,384 (14-bit) PWM steps and has 32 cycle off zones, leaving an active PWM region of 16,320 PWM steps ranging from 32 to 16,351. The PWM phase for outputs R0, R2, R4, R6, G0, G2, G4, G6, B0, B2, B4, and B6 use phasing with the outputs on first and off second. Inverse phasing is used for outputs R1, R3, R5, R7, G1, G3, G5, G7, B1, B3, B5, and B7 as shown in Figure 3 to balance the timing of loads on the LED anode power supply.

In multiplexed operation, the subframes are shared between MUX0 and MUX1 active times, effectively reducing the number of subframes by 2.

## LED-Intensity Control Example

The three levels of intensity control are shown in Figure 2 for one LED output driver in a MAX6974 in nonmultiplexed mode. As an example, the CALDAC is set to

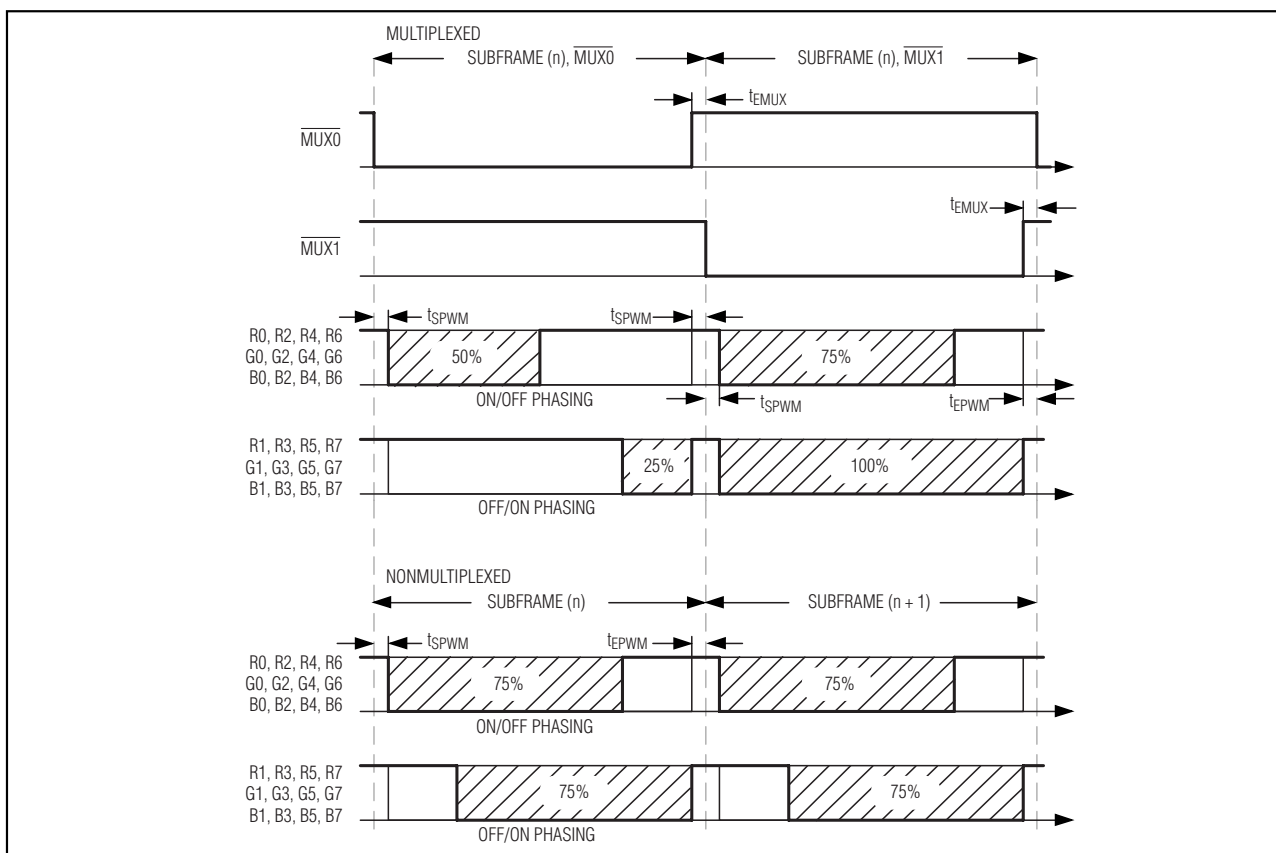

Figure 3. Multiplexed and Nonmultiplexed Output Driver Phasing and Example PWM Values

# 24-Output PWM LED Drivers for Message Boards

169DEC, setting the port output current level to 21.8mA. The global-intensity PDM value is set to 96DEC, producing an even distribution of ON subframes out of the 128 possible (shown in Figure 4 as subframes 1, 3, 4, 5, etc). Each subframe can be ON for a PWM duration set by the individual PWM value. The PWM value setting of 2560DEC out of 4096 (12-bit) results in a further reduction of current ON time (shown in bold trace).

The internal PDM logic spreads the on subframes as evenly as possible among the off subframes to keep the effective scanning frequency high.

For applications with a slower clock speed, the MAX6975 can increase the display refresh rate by a factor of four to eliminate visible flicker. Setting configuration bit D4 (GLB4) to 1 activates the increased refresh rate (see Table 6). The increased refresh rate reduces the number of global-intensity settings by a factor of four (see Table 3).

### MAX6974 Video-Frame Timing

The MAX6974 supports up to 60 video frames per second (fps). The following equation shows the required clock frequency to support 60 video fps:

$$60 \text{ (video fps)} \times 4096 \text{ (clocks per 12-bit PWM period)} \times 128 \text{ (global-intensity subframes)} = 31.5\text{MHz.}$$

The MAX6974 supports up to a 33MHz clock signal (~63fps).

Each 12-bit PWM period contains 4096 clock cycles; multiply that number by 128 (number of global-intensity subframes) to obtain the required number of clock cycles (524,288) per video frame. The MAX6974 requires 36 bits (12 bits per color multiplied by three colors) to drive an RGB pixel. The maximum pixel data that the MAX6974 can send per video frame is  $524,288 / 36$  or 14,563 pixels, corresponding to 1820 cascaded MAX6974s.

### MAX6975 Video-Frame Timing

The MAX6975 also supports up to 60 video frames per second (fps). The following equation shows the required clock frequency to support 60 video fps:

$$60 \text{ (video fps)} \times 16,384 \text{ (clocks per 14-bit PWM period)} \times 32 \text{ (global-intensity subframes)} = 31.5\text{MHz.}$$

The MAX6975 supports up to a 33MHz clock signal (~63fps).

Each 14-bit PWM period contains 16,384 clock cycles; multiply 16,384 by 32 (global-intensity subframes) to obtain the required number of clock cycles (524,288) per video frame. The MAX6975 requires 42 bits (14 bits per color multiplied by three colors) to drive an RGB pixel. The maximum pixel data that the MAX6975 can send per video frame is  $524,288 / 42$  or 12,483 pixels, corresponding to 1560 cascaded MAX6975s.

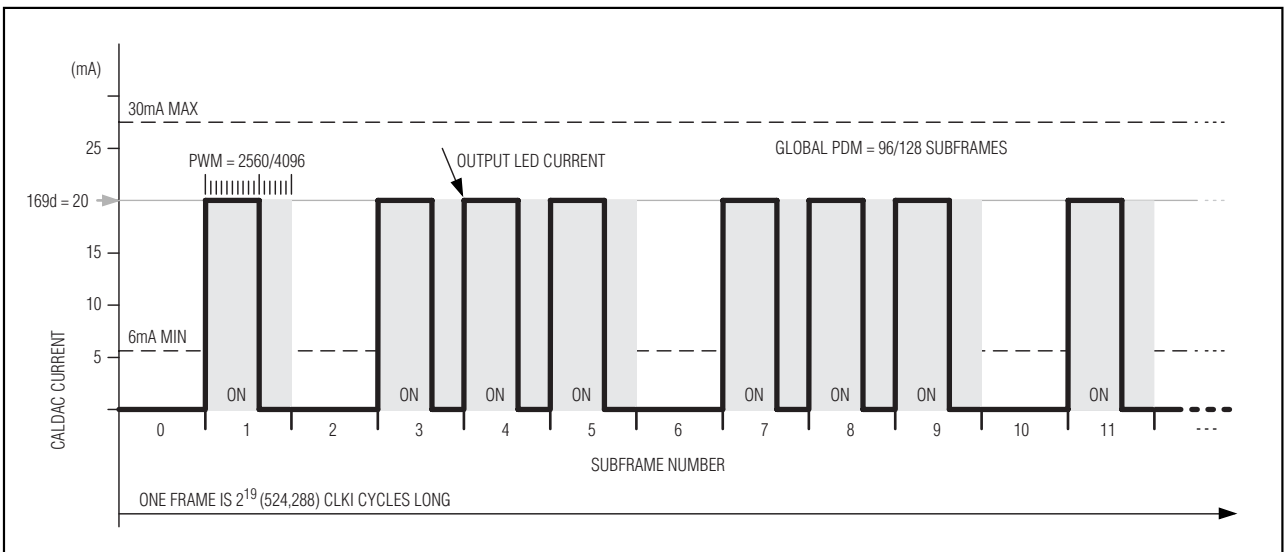

Figure 4. The three levels of LED current control (CALDAC, global-intensity PDM, and individual PWM) modulate the average output current.

# 24-Output PWM LED Drivers for Message Boards

## Multiplexed vs. Nonmultiplexed Operation

The MAX6974/MAX6975 can double the number of LEDs driven from 24 to 48 through multiplexing. When

multiplexing, the two outputs,  $\overline{\text{MUX0}}$  and  $\overline{\text{MUX1}}$ , drive two external pnp transistors, such as FMRTL717, used as common-anode power switches (see Figure 5).

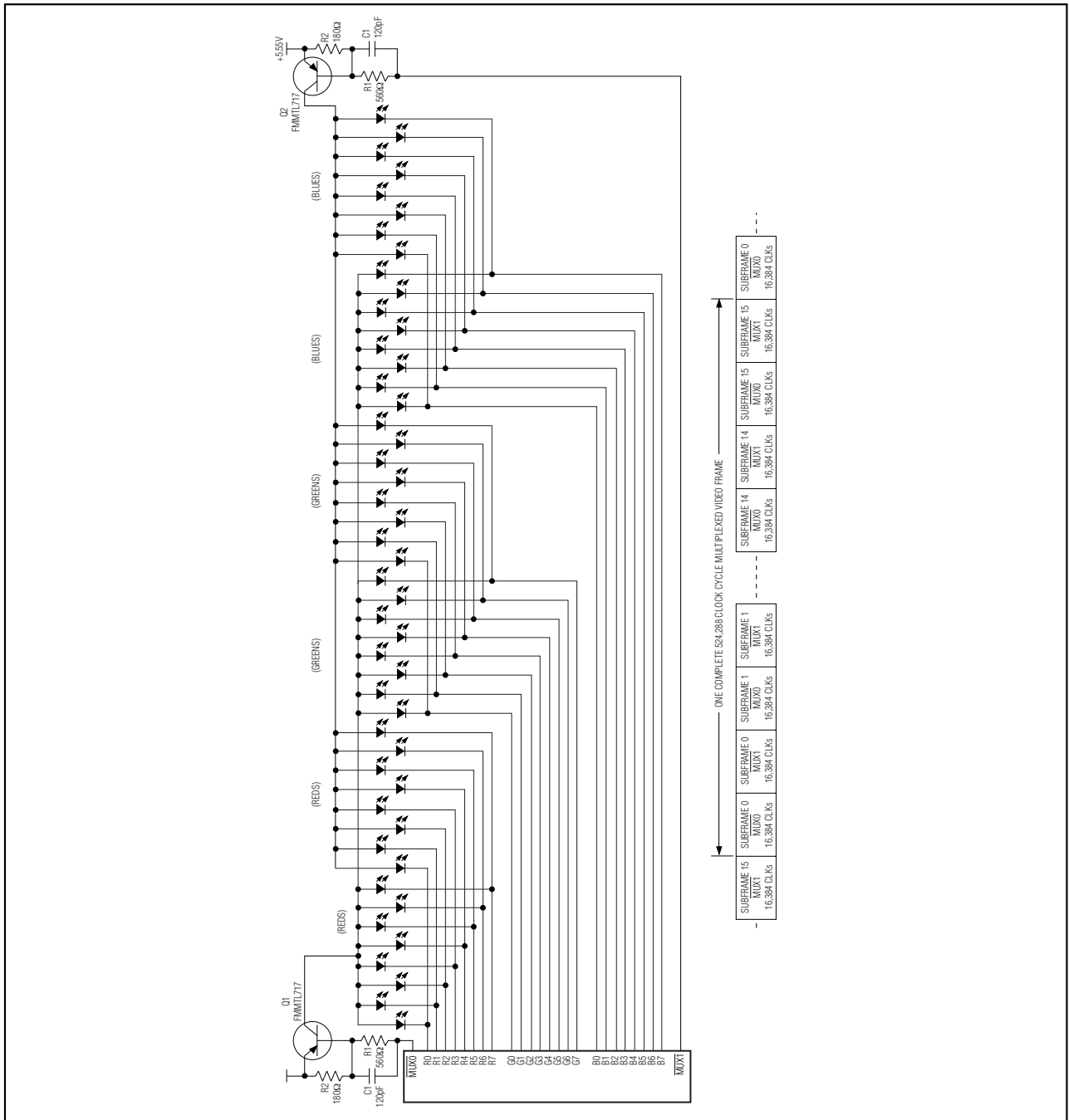

Figure 5. MAX6975 Multiplexing Two Sets of Eight RGB Pixels with a Single LED Supply and Subframe Timing

# 24-Output PWM LED Drivers for Message Boards

MAX6974/MAX6975

**Table 3. MAX6974/MAX6975 Timing Comparison**

PART	MUX BIT	OPERATION	PWM RES.	TOTAL CLOCKS PER PWM SUBFRAME	USEABLE CLOCKS PER PWM SUBFRAME	MAXIMUM PWM DUTY CYCLE
MAX6974	0	Nonmultiplex	12 bits	4096	4064	4064 / 4096 = 99.22%
	1	Multiplex				
MAX6975	0	Nonmultiplex	14 bits	16,384	16,320	16,320 / 16,384 = 99.61%
	1	Multiplex				

PART	GLB4 BIT	MUX BIT	OPERATION	GLOBAL PDM RES.	SUBFRAMES PER FRAME	CLOCKS PER FRAME	CLOCK FREQUENCY (MHz) FOR 50fps	CLOCK FREQUENCY (MHz) FOR 60fps
MAX6974	X	0	Nonmultiplex	7 bits	128	524,288	26.2144	31.45728
	X	1	Multiplex	6 bits	64			
MAX6975	0	0	Nonmultiplex	5 bits	32	524,288	26.2144	31.45728
		1	Multiplex	4 bits	16			
	1	0	Nonmultiplex	3 bits	8	131,072	6.5536	7.8643
		1	Multiplex	2 bits	4			

Setting configuration bit D0 to 1 enables multiplex operation. MUX0 and MUX1 alternate the LED anode drive voltage between two sets of LEDs. The R, G, and B ports provide individual PWM control during alternate MUX cycles as shown in Figure 3. The alternating MUX cycles reduce the global-intensity resolution (the number of subframes) by half, which reduces the average LED current by half.

### Watchdog

A selectable watchdog timer monitors serial-interface inputs CLKI, DIN, and LOADI. Enabling the watchdog timer requires that CLKI, DIN, and LOADI toggle at least once every 40ms. If any of these transitions fails to occur, then the individual-intensity PWM data latches clear. This condition effectively blanks the LEDs. Update the individual-intensity PWM data registers to turn the LEDs back on. The watchdog timeout does not affect the calibration or global-intensity data, the clock synchronization, or multiplexed/nonmultiplexed setting.

Use the watchdog functionality in safety-critical applications where a blanked display is safer than an incorrect display.

### LED Open-Circuit and Overtemperature Detection

The MAX6974/MAX6975 feature two fault detection functions: open-circuit LED outputs and overtemperature. An LED open circuit is detected on driver outputs by monitoring for output voltages below 200mV. When an open circuit is detected, the MAX6974/MAX6975 increments a fault counter included in the serial-interface protocol that can be routed back to the host transmitter for diagnostics. Any number of open-circuit LEDs, multiplexed or nonmultiplexed, can be detected, however, only one counter increment occurs per device.

The MAX6974/MAX6975 detect die temperatures above  $T_{DIE} = +165^{\circ}\text{C}$  and disable all output drivers by setting all PWM data to zero. The fault counter in the serial-interface protocol is incremented by one count for each cascaded device with an overtemperature condition. The output drivers are turned back on when the die temperature falls below  $T_{DIE} = +150^{\circ}\text{C}$ . The fault counter value is distinguished between LED open-circuit and overtemperature conditions by the serial-interface command used at the time of detection (see the *Serial Interface* section for more details).

## 24-Output PWM LED Drivers for Message Boards

### Commands

The MAX6974/MAX6975 have four commands used to load all operating mode and LED output current data. Each command is uniquely identified by two bits, C1 and C0, embedded in the serial-interface protocol structure. The commands Load CALDAC, Load Global-Intensity PDM, and Load Configuration each require 24 bits of data (3 bytes) for every cascaded device. The number of bits required for the command load individual PWM varies by device and multiplex mode of operation. Each cascaded device can receive unique data for CALDACs, global intensity, configuration, and individual PWM output drivers. Generally, all cascaded devices are operated in the same configuration mode. The data bytes are transmitted MSB first for all commands. The commands are communicated to all cascaded devices by the host using the synchronous serial-interface and protocol structure (see the *Serial Interface* section for details). The four commands and the data lengths for each command are shown in Table 4.

The MAX6974, operating in nonmultiplexed mode, requires twenty-four 12-bit individual PWM data (288 bits total) and requires forty-eight 12-bit data (576 bits total) in multiplexed operation mode. Similarly, the MAX6975, operating in nonmultiplexed mode, requires twenty-four 14-bit individual-intensity PWM data (336

bits total) and requires forty-eight 14-bit (672 bits total) data in multiplexed mode. The individual PWM data are loaded into an intermediate latch and transferred to the actual PWM latches at subframe 0 and PWM clock 0.

The R, G, and B calibration DACs are loaded with 8-bit data each in nonmultiplexed and multiplexed modes. Data is updated immediately into the CALDAC latches (see Table 8).

The MAX6974/MAX6975 require one data byte to set the global-intensity PDM for all output drivers. The global-intensity PDM data has a variable number of active bits depending on the multiplex operating mode and, for the MAX6975, the global-quarter setting. The number of bits used for global-intensity control is always justified to the LSB of the data byte, as shown in Table 5. One byte of data is sent three times with the global-intensity PDM data bits justified to the LSB. Data is updated into the PWM latches at subframe 0 and PWM clock 0 (see Table 9).

When using the MAX6975 5-bit global-intensity setting, the settings range from 0 to 63 to set the global intensity from 1 to 64 subframes ON to 64 out of 64 subframes ON. When using the MAX6974 7-bit global-intensity setting, the settings range from 0 to 127 to set the global intensity from 1 out of 128 subframes ON to 128 out of 128 subframes ON.

**Table 4. Commands and Data Length**

CMD[1:0]		COMMAND	DATA LENGTH PER CASCADED DEVICE
C1	C0		
0	0	Load individual PWM	288 bits (MAX6974 nonmultiplexed)
			576 bits (MAX6974 multiplexed)
			336 bits (MAX6975 nonmultiplexed)
			672 bits (MAX6975 multiplexed)
0	1	Load CALDAC	24 bits
1	0	Load global-intensity PDM	24 bits
1	1	Load configuration	24 bits

**Table 5. Global-Intensity Data Bit Justification**

PART	GLB4	MUX	TOTAL BITS	MSB D7	D6	D5	D4	D3	D2	D1	LSB D0
MAX6974	X	0	7	0	Bit[6]	Bit[5]	Bit[4]	Bit[3]	Bit[2]	Bit[1]	Bit[0]
	X	1	6	0	0	Bit[5]	Bit[4]	Bit[3]	Bit[2]	Bit[1]	Bit[0]
MAX6975	0	0	5	0	0	0	Bit[4]	Bit[3]	Bit[2]	Bit[1]	Bit[0]
	0	1	4	0	0	0	0	Bit[3]	Bit[2]	Bit[1]	Bit[0]
	1	0	3	0	0	0	0	0	Bit[2]	Bit[1]	Bit[0]
	1	1	2	0	0	0	0	0	0	Bit[1]	Bit[0]

## 24-Output PWM LED Drivers for Message Boards

The global-intensity data is received in an intermediate register and is applied to the outputs at subframe 0 and PWM clock 0.

The MAX6974/MAX6975 have one byte of configuration data with 5 active bit settings as shown in Table 6. One byte of data containing configuration bit settings is sent three times. Data is updated immediately into the CAL-DAC latches. See Table 10. The loaded configuration settings take effect immediately.

### Serial Interface

The MAX6974/MAX6975 feature a fully synchronous and fully buffered serial interface that allows cascading of multiple devices. The serial interface consists of inputs (CLKI, DIN, and LOADI) and outputs (CLKO, DOUT, and LOADO). The MAX6974/MAX6975 can pass different data to each cascaded device without any additional inputs to identify the position of the devices in the cascaded chain.

MAX6974/MAX6975

**Table 6. Load Configuration Bit Definitions**

CONFIGURATION BIT	ACRONYM	FUNCTION	DESCRIPTION
MSB D7	—	0	Not used
D6	—	0	Not used
D5	—	0	Not used
D4	GLB4	Global quarter	Enables the reduced global-intensity setting in the MAX6975 when set to 1. When set, the MAX6975 uses eight (or four, if multiplexing) PWM subframes. GLB4 is set to 0 as power-on default. Setting bit D4 has no effect in the MAX6974.
D3	PWM-ON	Enable individual PWMs	Turns all individual PWM outputs on when set to 1. Power-on default is PWM-ON set to 0 to disable all current output drivers. PWM-ON can be used to turn all LEDs on or off without affecting the global-intensity or individual PWM settings.
D2	CRST	Reset frame and PWM counters	Setting CRST to 1 synchronously resets internal counters to 0. This action sets the MAX6974/MAX6975 to subframe 0 of the global-intensity subframe counter and clock 0 of all individual PWM counters. The CRST bit is a nonlatching control function that resets to 0 after the counters are set to 0.
D1	WDOG	Watchdog enable	Setting WDOG to 1 enables the watchdog timer operation. Power-on default is 0.
LSB D0	MUX	Multiplex enable	Setting MUX to 1 turns multiplex mode on. Power-on default is 0.

## 24-Output PWM LED Drivers for Message Boards

The serial interface uses the continuously running clock, CLKI, to synchronously transfer and latch data (33MHz max). The MAX6974/MAX6975 sample inputs DIN and LOADI on the rising edge of CLKI and update outputs DOUT and LOADO on the rising edge of CLKI. The MAX6974/MAX6975 specifications guarantee that cascaded devices observe setup and hold timing from device to device, making external buffers and clock trees unnecessary, even in very large systems.

The high-speed CLKI, CLKO, DIN, and DOUT signals use low-voltage differential signaling (LVDS), and the less frequently changing control signals, LOADI and LOADO, use standard CMOS. The differential signals are generally referred to in unipolar shorthand; for example, the statement "CLKI rising edge" means that CLKI+ is rising, and CLKI- is falling.

The MAX6974/MAX6975 use LVDS drivers with differential signaling (300mV nominal logic swing around a +1.2V bias) and cascaded CMOS control signals to minimize signal-path EMI and simplify interface timing and PC board layout. Note the differential inputs for the first driver can be driven from +3.3V CMOS using LVDS level translators, such as the MAX9112 terminated with 110Ω (see Figure 12).

A 25MHz to 33MHz clock frequency is recommended to keep the display refresh rate high. When using the MAX6975 in reduced global-intensity mode (GLB4 = 1 in configuration register), the recommended clock frequency range is 6MHz to 33MHz.

### Serial-Interface Protocol Structure

The MAX6974/MAX6975 serial interface transfers all data and control functions using a protocol structure consisting of header, data, and optional tail segments transmitted in this sequence. The header and tail

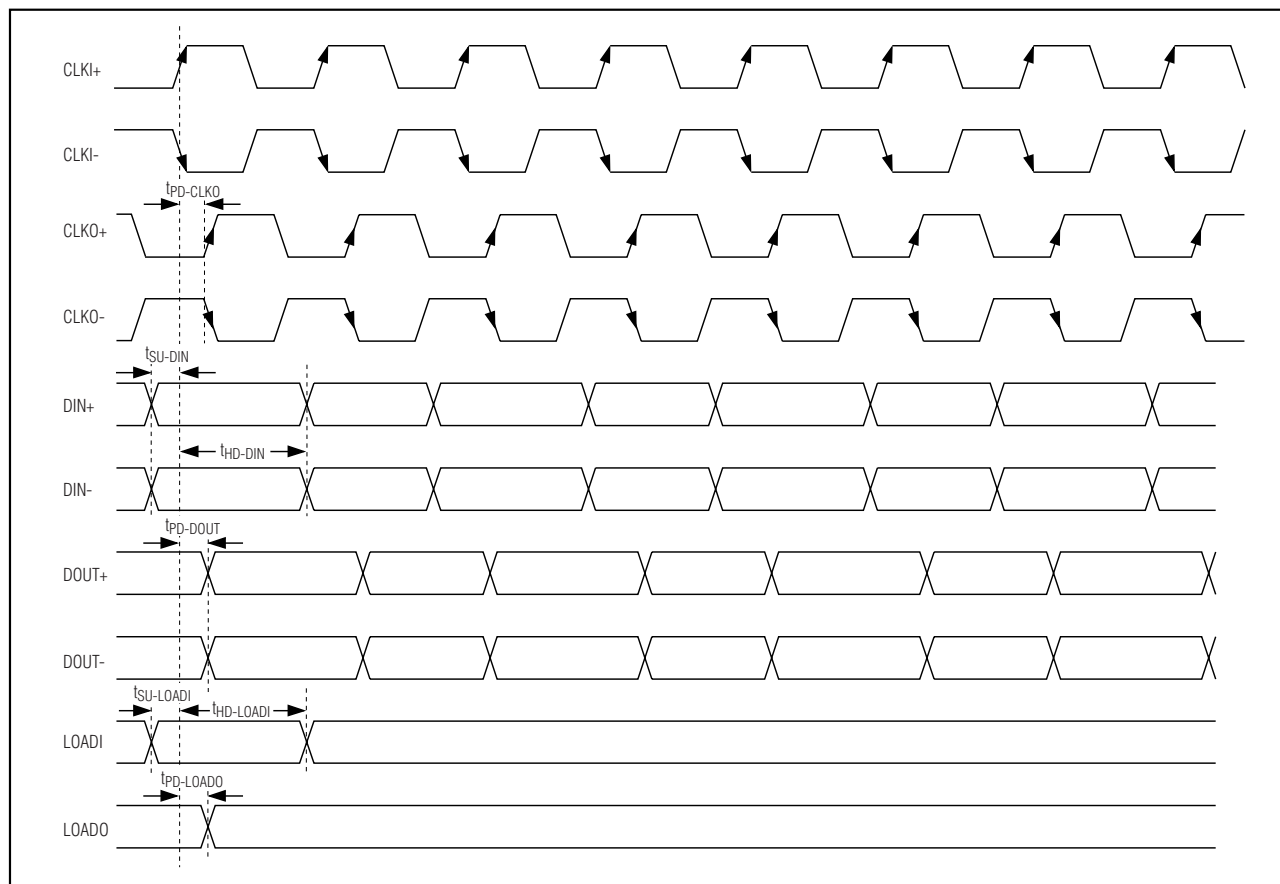

Figure 6. Serial-Interface Timing



# 24-Output PWM LED Drivers for Message Boards

segments transfer to all cascaded devices, while the data section reduces in bit length as data transfers through the cascaded devices. When LOADI is low, the MAX6974/MAX6975 continuously monitor DIN for reception of the SYNC pattern (see the *Header Segment* section).

### Header Segment

The 24-bit header segment consists of an 8-bit fixed synchronization pattern (SYNC), a 6-bit command pattern (CMD), and a 10-bit counter (CNTR) segment (see Table 7). LOADI must change from low to high within plus or minus one clock cycle of the first command bit. When the SYNC bit pattern 0xE8 is recognized, LOADI is monitored for the rising edge, allowing the device to internally synchronize LOADI to CLKI. The six command bits, CMD[5:0], consist of bits C1 and C0 repeated three times. The four commands used by the MAX6974/MAX6975 are defined by the two bits, C1 and C0. The counter segment is incremented by one for each cascaded device with an internal fault detected. Use the counter segment to collect fault data across the cascaded chain.

### HDR[23:0]

Complete 24-bit header segment.

### SYNC[7:0]

Synchronization bit pattern 0xE8 is recognized by the MAX6974/MAX6975 during intervals when LOADI is low. The SYNC bit pattern, followed by the rising edge of

LOADI, internally synchronizes the timing relationship between CLKI and DIN with the LOADI signal. The synchronization pattern must be 0xE8.

### CMD[5:0]

Send command bits C1 and C0 three times in succession. The command bits define how many data bits are received and where the data is loaded. The four commands are:

C1:C0	COMMAND	CMD[5:0]
00	Load individual PWM	000000
01	Load CALDAC	010101
10	Load global-intensity PDM	101010
11	Load configuration	111111

### CNTR[9:0]

This is the counter for open LED or overtemperature fault conditions. The host sends the header segment with the counter value set to zero. The counter value is incremented one count by each device that detects a fault condition in the cascaded chain. The accumulated count value returns to the host from the last device in the cascade chain. The command determines which fault type is incremented to the counter (see *LED Open-Circuit and Overtemperature Detection Counter* section):

CMD[1:0] = X0      Overtemperature faults counted

CMD[1:0] = X1      Open LED faults counted

**Table 7. Serial-Interface Header**

HDR																							
23	22	21	20	19	18	17	16	15	14	13	12	11	10	9	8	7	6	5	4	3	2	1	0
SYNC								CMD						CNTR									
7	6	5	4	3	2	1	0	1	0	1	0	1	0	9	8	7	6	5	4	3	2	1	0
1	1	1	0	1	0	0	0	C1	C0	C1	C0	C1	C0	b9	b8	b7	b6	b5	b4	b3	b2	b1	b0

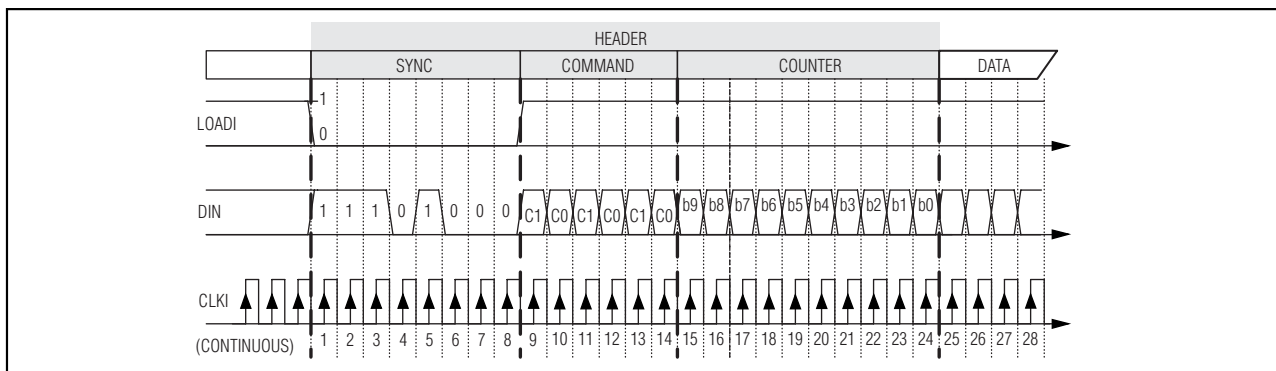

Figure 7. Header-Segment Timing

## 24-Output PWM LED Drivers for Message Boards

### Data Segment

The bit length of the data segment received by the MAX6974/MAX6975 is dependent on the command specified in the header.

The load CALDAC command has three unique data bytes, while load global-intensity PDM and load configuration each have one byte of data repeated three times. The CALDAC data within the command load CALDAC is sent with B CALDAC data first, followed by G CALDAC data, and then R CALDAC data, as shown in Table 8.

The data segment of the load individual PWM command has a variable length depending on specific device and configuration settings. The data is always organized

as B driver data first in the order of B7 first to B0 last (MSB first), followed by the G driver data in the same order of G7 to G0 (MSB first), and then the R driver data in the order of R7 to R0 (MSB first).

### Tail Segment

The MAX6974/MAX6975 allow for an optional string of data bits to be transmitted following all device data bits, which is referred to as the tail segment. The data bits of the tail segment are clocked back to the host, following the header, from the last device in a cascaded chain. The number of bits in the tail segment is optional. The tail carries no device-specific data on DIN, but provides feedback confirmation to the host that all data bits were extracted by all devices in the cascade chain.

**Table 8. Serial Format for Load CALDAC**

HEADER	DATA 1	DATA 2	DATA 3	...	DATA N
HDR[23:0]	B[7:0] G[7:0] R[7:0]	B[7:0] G[7:0] R[7:0]	B[7:0] G[7:0] R[7:0]	...	B[7:0] G[7:0] R[7:0]

B[7:0] 8-bit data loaded into port B CALDAC

G[7:0] 8-bit data loaded into port G CALDAC

R[7:0] 8-bit data loaded into port R CALDAC

N Number of cascaded devices

**Table 9. Serial Format for Load Global-Intensity PDM**

HEADER	DATA 1	DATA 2	DATA 3	...	DATA N
HDR[23:0]	D[7:0] D[7:0] D[7:0]	D[7:0] D[7:0] D[7:0]	D[7:0] D[7:0] D[7:0]	...	D[7:0] D[7:0] D[7:0]

D[7:0] Send the 8-bit data for the global-intensity PDM three times (24 total bits)

**Table 10. Serial Format for Load Configuration**

HEADER	DATA 1	DATA 2	DATA 3	...	DATA N
HDR[23:0]	D[7:0] D[7:0] D[7:0]	D[7:0] D[7:0] D[7:0]	D[7:0] D[7:0] D[7:0]	...	D[7:0] D[7:0] D[7:0]

D[7:0] Send the 8-bit configuration data three times (24 total bits)

**Table 11. Serial Format for Load Individual PWM (Nonmultiplexed)**

HEADER	DATA 1	DATA 2	DATA 3	...	DATA N
HDR[23:0]	B7, B6, ...R0	B7, B6, ...R0	B7, B6, ...R0	...	B7...R0

B...G...R\_ 12-bit (MAX6974) or 14-bit (MAX6975) data each

**Table 12. Serial Format for Load Individual PWM (Multiplexed)**

HEADER	DATA 1	DATA 2	DATA 3	...	DATA N
HDR[23:0]	B7, B7', B6, B6', ...R0'	B7, B7', B6, B6', ...R0'	B7, B7', B6, B6', ...R0'	...	B7, B7', B6, B6', ...R0'

B\_ 12-bit (MAX6974) or 14-bit (MAX6975) PWM data for each output B\_ during multiplex phase  $\overline{\text{MUX0}}$ , MSB first

B\_' 12-bit (MAX6974) or 14-bit (MAX6975) PWM data for each output B\_ during multiplex phase  $\overline{\text{MUX1}}$ , MSB first

G\_ 12-bit (MAX6974) or 14-bit (MAX6975) PWM data for each output G\_ during multiplex phase  $\overline{\text{MUX0}}$ , MSB first

G\_' 12-bit (MAX6974) or 14-bit (MAX6975) PWM data for each output G\_ during multiplex phase  $\overline{\text{MUX1}}$ , MSB first

R\_ 12-bit (MAX6974) or 14-bit (MAX6975) PWM data for each output R\_ during multiplex phase  $\overline{\text{MUX0}}$ , MSB first

R\_' 12-bit (MAX6974) or 14-bit (MAX6975) PWM data for each output R\_ during multiplex phase  $\overline{\text{MUX1}}$ , MSB first

# 24-Output PWM LED Drivers for Message Boards

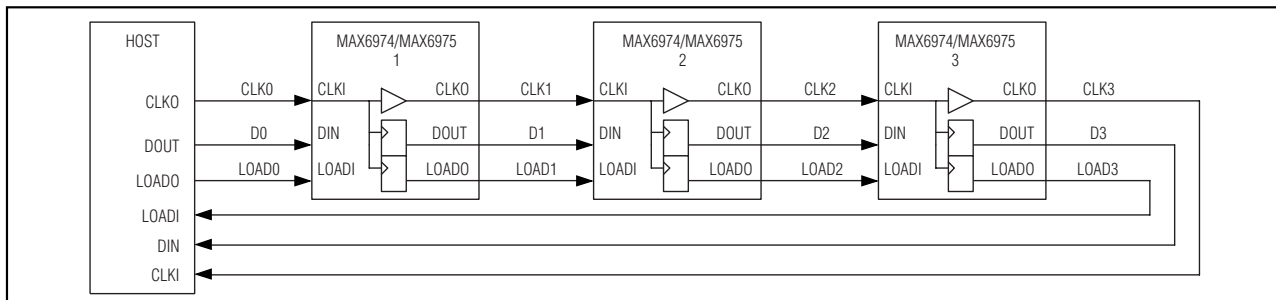

Figure 8. Example Showing Three-Device Cascade Connection Scheme with the Interconnecting Nodes Labeled for Clarity

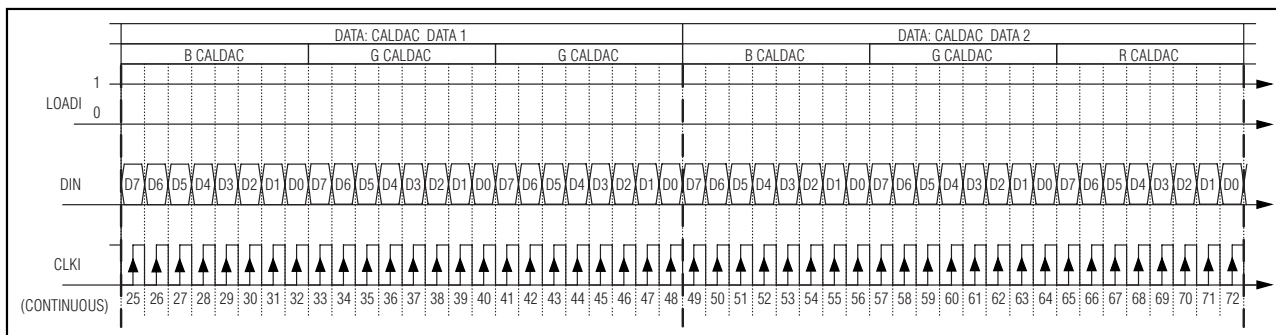

Figure 9. Timing Example Showing CALDAC Data Set for the First Two Cascaded Devices

## Serial-Interface Cascade Timing

The MAX6974/MAX6975 serial-interface protocol timing is simplified by the guaranteed setup and hold characteristics of the outputs from one device driving the inputs of another. An example of a cascade of three MAX6974/MAX6975 devices is shown in Figure 8.

## Example of Serial-Interface Cascade Timing

The basic timing of a MAX6974/MAX6975 cascaded chain of three devices demonstrates the principle that applies to any number of cascaded devices. The first device connected to the host transmitter is referenced as 1, and the remaining devices are referenced as 2 and 3. Device 3 outputs connect to the host for communicating diagnostic and fault counter data.

The first MAX6974/MAX6975, device 1, receives the header and captures the first set of data bits. The number of captured bits is determined by the command given in the header. A timing example of the data transfer for the Load CALDAC command is shown in Figure 9. Device 1 does not send the captured data out on DOUT. Instead, device 1 sends out a new header 25 clock cycles after the reception of the first header bit on DIN. The data flow on each interconnect node is shown in Figure 10.

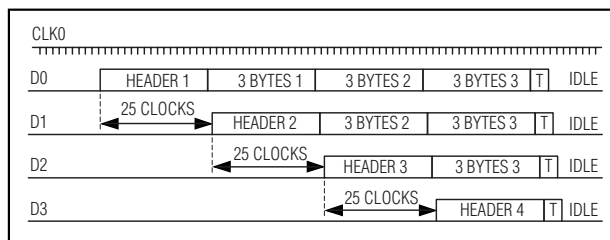

Figure 10. Data Cascading Example for 24-Bit Data Words

After capturing the first data set, device 1 transmits all following data segments and the optional tail segment on DOUT, delayed by one CLKI cycle. Device 2 receives the new header from device 1, followed by data that now begins with device 2's data set. Device 2 repeats the same process as described above; capturing the first data set received, appending a new header, and passing all subsequent data out DOUT to the next device 3. Device 3 captures the last data set and transmits a header followed by the tail segment. The last header and tail segments are clocked back into the host receiver. The header received by the host contains the updated fault counter data. The tail data bit pattern can be compared to the tail data originally transmitted by the host for data integrity check.

# 24-Output PWM LED Drivers for Message Boards

When the MAX6974/MAX6975 send individual-intensity PWM data, the data segment bit length is large due to the 12-bit or 14-bit PWM data for each of the 24 outputs (see Figure 11). The various data segment bit lengths for each of the four commands and different operating modes is shown in Table 4. Data capturing is the same as described above with the header segment outputs and data being delayed by the full length of the data bit stream being captured plus one clock cycle.

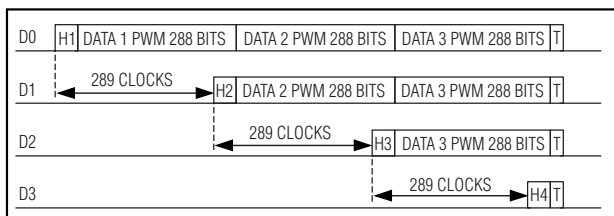

Figure 11. Long (288 Bits) PWM Data Cascading Shown for MAX6974 in Nonmultiplexed Mode

## LED Open-Circuit and Overtemperature Detection Counter

The MAX6974/MAX6975 feature LED open-circuit detection and overtemperature detection that use the counter section of the header segment to record detected faults. Using commands 01 or 11 force the counter to record LED open-circuit detection faults. Using commands 00 or 10 force the counter to record overtemperature faults.

The MAX6974/MAX6975 detect an open circuit on a driver output by monitoring for output voltages below 200mV. When an open circuit is detected, the MAX6974/MAX6975 increment the counter segment data, CNTR[9:0], received on DIN by 1 before transmitting a

header and new counter value out DOUT. Regardless of the number of open-circuit outputs on a device, the counter increment is 1.

The MAX6974/MAX6975 detect die temperatures above  $T_{DIE} = +165^{\circ}\text{C}$  and disable all output drivers by setting all PWM data to zero. During an overtemperature event, the MAX6974/MAX6975 increment the counter segment data, CNTR[9:0], received on DIN by 1 before transmitting a header and new counter value out DOUT. The output drivers are allowed to be on when the die temperature falls below  $T_{DIE} = +150^{\circ}\text{C}$ .

When there is no fault detected, the counter data is passed directly to DOUT unaltered.

## Applications Information

### Terminations and PC Board Layout

The MAX6974/MAX6975's layout simplifies cascading multiple devices, as the interface signals flow through from each device. The synchronous and buffered nature of the interface simplifies the board design, but pay attention to signal routing and termination, as with other high-speed logic circuits.

Terminate the differential input pairs, CLKI+ and CLKI-, as well as DIN+ and DIN-, with a termination resistor as close as possible to the package. When using the MAX6974/MAX6975 as the signal source, use a 200Ω termination resistor. When using a level translator or clock retimer as the signal source, use a 110Ω termination resistor. Route each differential input pair as close parallel tracks with spacing or a GND trace between the track pair and the next signal track to minimize cross-coupling. Track lengths up to a few inches do not require termination-matched tracks (transmission lines).

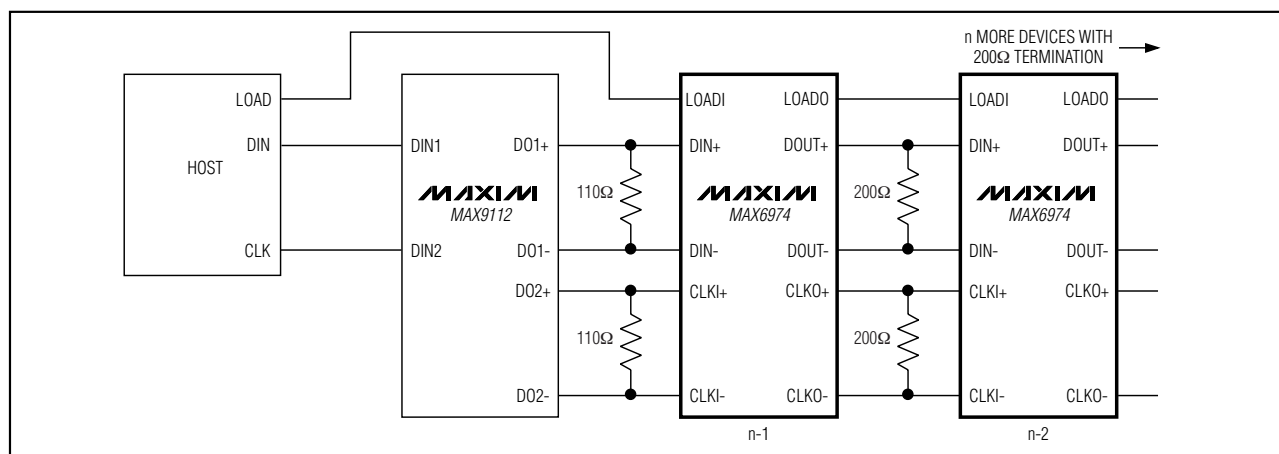

Figure 12. Typical Cascaded Serial-Interface Termination Circuit

## 24-Output PWM LED Drivers for Message Boards

Use the same length interface signal paths, whether differential or CMOS, to ensure a uniform propagation delay for each signal.

### Power-Supply Considerations

The MAX6974/MAX6975 operate with a power-supply voltage of 3.0V to 3.6V. Bypass the V<sub>DD</sub> power supply to GND with a 0.1µF ceramic capacitor as close as possible to the device pins. If the LED supply is shared with the V<sub>DD</sub> supply, adequately decouple the V<sub>DD</sub> supply with bulk capacitance to ensure that the fast-rising, high-current LED drive currents do not cause transient dips in V<sub>DD</sub>.

### Driving LEDs from a Supply Higher than 7V

An external npn transistor in a cascode configuration extends the output drive voltage above 7V. The external pass transistor's emitter clamps to a V<sub>BE</sub> below its base, which is connected to the MAX6974/MAX6975's supply voltage. An optional emitter resistor reduces the voltage drop across the MAX6974/MAX6975's output transistor and effectively takes the dissipation off the device into the resistor. The external transistor's collector current is equal to its emitter current (less a small base current), and the MAX6974/MAX6975 accurately control the emitter current with a constant current sink driver structure.

Example of using an external npn transistor:

V<sub>DD</sub> = 3.3V ±5%, I<sub>OUT</sub> = 30mA, external pass transistor V<sub>BE</sub> = 0.7V to 1V at 30mA emitter current.

For best output current accuracy, design V<sub>O</sub> to be at least 1.2V:

$$R1_{(MAX)} = (3.15 - 1 - 1.2) / 0.030 = 31.7\Omega, \text{ so choose } R1 = 30\Omega.$$

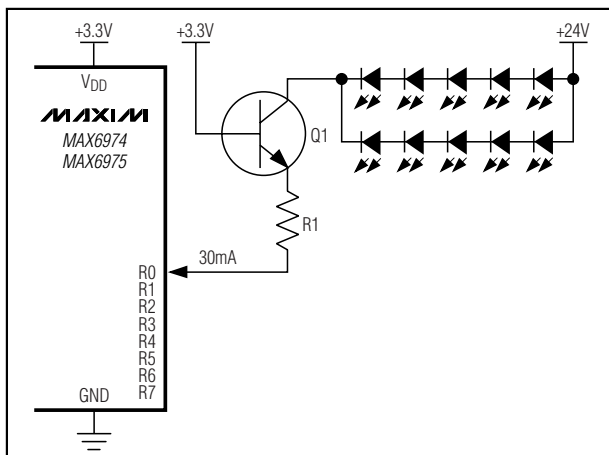
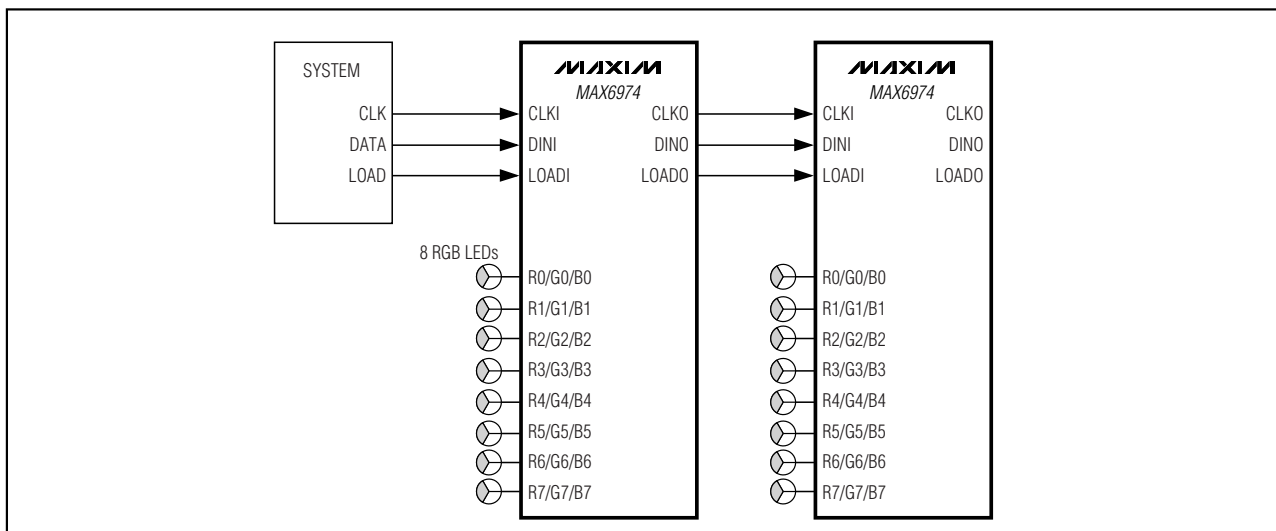

Figure 13. External Cascode npn Transistor

### Typical Operating Circuit



### Chip Information

PROCESS: BiCMOS

# 24-Output PWM LED Drivers for Message Boards

## Package Information

(The package drawing(s) in this data sheet may not reflect the most current specifications. For the latest package outline information, go to [www.maxim-ic.com/packages](http://www.maxim-ic.com/packages).)

QFN THINLEPS

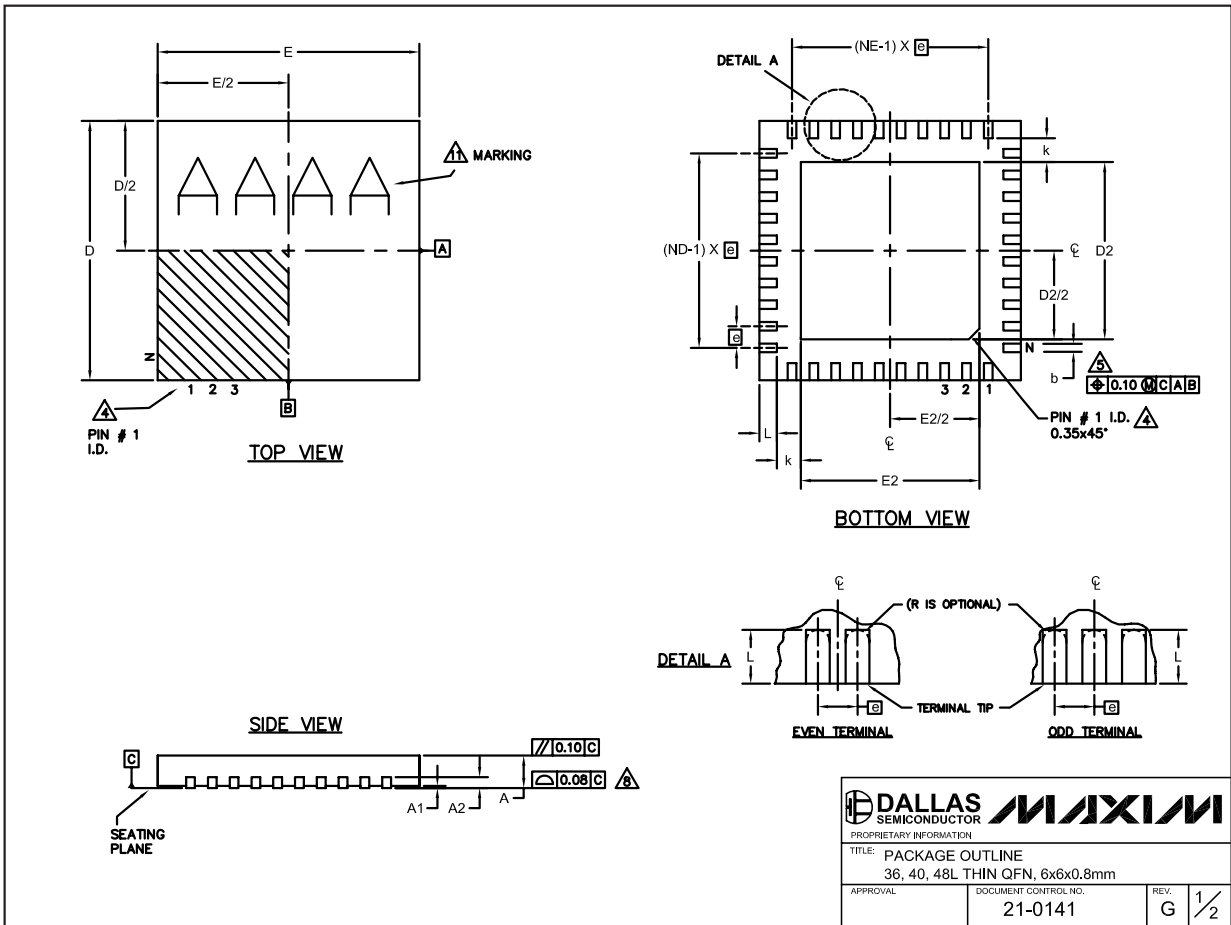

<small>PROPRIETARY INFORMATION</small>	
<b>TITLE:</b> PACKAGE OUTLINE 36, 40, 48L THIN QFN, 6x6x0.8mm	
<small>APPROVAL</small>	<small>DOCUMENT CONTROL NO.</small> 21-0141
<small>REV.</small> G	<small>REV.</small> 1/2

# 24-Output PWM LED Drivers for Message Boards

## Package Information (continued)

(The package drawing(s) in this data sheet may not reflect the most current specifications. For the latest package outline information, go to [www.maxim-ic.com/packages](http://www.maxim-ic.com/packages).)

MAX6974/MAX6975

COMMON DIMENSIONS									
PKG. SYMBOL	36L 6x6			40L 6x6			48L 6x6		
	MIN.	NOM.	MAX.	MIN.	NOM.	MAX.	MIN.	NOM.	MAX.
A	0.70	0.75	0.80	0.70	0.75	0.80	0.70	0.75	0.80
A1	0	0.02	0.05	0	0.02	0.05	0	-	0.05
A2	0.20 REF.			0.20 REF.			0.20 REF.		
b	0.20	0.25	0.30	0.20	0.25	0.30	0.15	0.20	0.25
D	5.90	6.00	6.10	5.90	6.00	6.10	5.90	6.00	6.10
E	5.90	6.00	6.10	5.90	6.00	6.10	5.90	6.00	6.10
e	0.50 BSC.			0.50 BSC.			0.40 BSC.		
k	0.25	-	-	0.25	-	-	0.25	-	-
L	0.45	0.55	0.65	0.30	0.40	0.50	0.30	0.40	0.50
N	36			40			48		
ND	9			10			12		
NE	9			10			12		
JEDEC	WJJD-1			WJJD-2			-		

EXPOSED PAD VARIATIONS						
PKG. CODES	D2			E2		
	MIN.	NOM.	MAX.	MIN.	NOM.	MAX.
T3666-2	3.60	3.70	3.80	3.60	3.70	3.80
T3666-3	3.60	3.70	3.80	3.60	3.70	3.80
T3666N-1	3.60	3.70	3.80	3.60	3.70	3.80
T4066-2	4.00	4.10	4.20	4.00	4.10	4.20
T4066-3	4.00	4.10	4.20	4.00	4.10	4.20
T4066-4	4.00	4.10	4.20	4.00	4.10	4.20
T4066-5	4.00	4.10	4.20	4.00	4.10	4.20
T4866-1	4.40	4.50	4.60	4.40	4.50	4.60
T4866-2	4.40	4.50	4.60	4.40	4.50	4.60

### NOTES:

1. DIMENSIONING & TOLERANCING CONFORM TO ASME Y14.5M-1994.
2. ALL DIMENSIONS ARE IN MILLIMETERS. ANGLES ARE IN DEGREES.
3. N IS THE TOTAL NUMBER OF TERMINALS.
4. THE TERMINAL #1 IDENTIFIER AND TERMINAL NUMBERING CONVENTION SHALL CONFORM TO JESD 95-1 SPP-012. DETAILS OF TERMINAL #1 IDENTIFIER ARE OPTIONAL, BUT MUST BE LOCATED WITHIN THE ZONE INDICATED. THE TERMINAL #1 IDENTIFIER MAY BE EITHER A MOLD OR MARKED FEATURE.
5. DIMENSION b APPLIES TO METALLIZED TERMINAL AND IS MEASURED BETWEEN 0.25 mm AND 0.30 mm FROM TERMINAL TIP.
6. ND AND NE REFER TO THE NUMBER OF TERMINALS ON EACH D AND E SIDE RESPECTIVELY.
7. DEPOPULATION IS POSSIBLE IN A SYMMETRICAL FASHION.
8. COPLANARITY APPLIES TO THE EXPOSED HEAT SINK SLUG AS WELL AS THE TERMINALS.
9. DRAWING CONFORMS TO JEDEC MO220, EXCEPT FOR 0.4mm LEAD PITCH PACKAGE T4866-1.
10. WARPAGE SHALL NOT EXCEED 0.10 mm.
11. MARKING IS FOR PACKAGE ORIENTATION REFERENCE ONLY.
12. NUMBER OF LEADS SHOWN FOR REFERENCE ONLY.

 	
<small>PROPRIETARY INFORMATION</small>	
TITLE PACKAGE OUTLINE 36, 40, 48L THIN QFN, 6x6x0.8mm	
APPROVAL	DOCUMENT CONTROL NO. 21-0141
REV. G	2/2

Maxim cannot assume responsibility for use of any circuitry other than circuitry entirely embodied in a Maxim product. No circuit patent licenses are implied. Maxim reserves the right to change the circuitry and specifications without notice at any time.

Maxim Integrated Products, 120 San Gabriel Drive, Sunnyvale, CA 94086 408-737-7600 23