

**3V AM/FM +MPX TUNER IC(FOR MECHANICAL TUNING)**

**DESCRIPTION**

The SA2111C is AM/FM single-chip tuner IC, which is designed for portable radios and 3V head phone radios. It is suitable for digit tuning system, and FM local oscillation voltage is set up low relatively, for NEW FCC.

**FEATURES**

- \* Operating supply voltage range:  $V_{CC}=1.8\sim 7V$  ( $T_{amb}=25^{\circ}C$ )
- \* AM detector coil, FM IFT, IF coupling condenser are not needed.
- \* For adopting ceramic discriminator, it is not necessary to adjust the FM quad detector circuit.
- \* Built-in FM MPX VCO circuit
- \* Built-in varactor diode for AFC
- \* Built-in AM low cut circuit
- \* Low supply current. ( $V_{CC}=3V$ ,  $T_{amb}=25^{\circ}C$ )

$ICC_q(FM)=9.0mA$  (Typ.)  
 $ICC_q(AM)=5.0mA$  (Typ.)

Note: Handle with care to prevent devices from deteriorations by ESD.

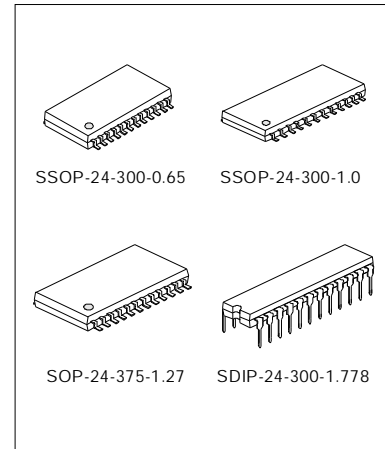

**ORDERING INFORMATION**

Device	Package
SA2111C	SDIP-24-300-1.778
SA2111CS	SSOP-24-300-0.65
SA2111CA	SOP-24-375-1.27
SA2111CB	SSOP-24-300-1.0

**BLOCK DIAGRAM**

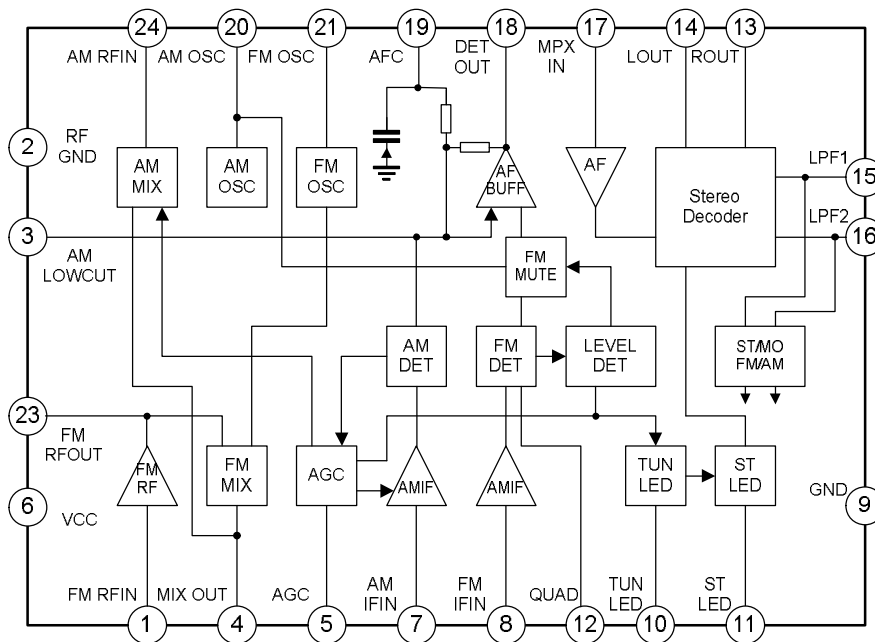

www.DataSheet4U.com

ABSOLUTE MAXIMUM RATINGS( $T_{amb}=25^{\circ}\text{C}$ )

Characteristic	Symbol	Value	Unit
Supply Voltage	VCC	8	V
LED Current	I <sub>LED</sub>	10	mA
LED Voltage	V <sub>LED</sub>	8	V
Power Dissipation	P <sub>D</sub> (note)	1200	mW
Operating Temperature	T <sub>opr</sub>	-20~+70	°C
Storage Temperature	T <sub>stg</sub>	-40~+125	°C

Note: Derated above  $T_{amb}=25^{\circ}\text{C}$  in the proportion of  $9.6\text{mW}/^{\circ}\text{C}$  for SA2111C.

ELECTRICAL CHARACTERISTICS(Unless otherwise specified,  $T_{amb}=25^{\circ}\text{C}$ ,  $V_{CC}=3\text{V}$ , F/E :  $f=98\text{ MHz}$ ,  $f_m=1\text{ kHz}$ , FM IF :  $f=10.7\text{ MHz}$ ,  $\Delta f = \pm 22.5\text{ kHz}$ ,  $f_m=1\text{ kHz}$ , AM :  $f=1\text{ MHz}$ , MOD=30%,  $f_m=1\text{ kHz}$ , MPX:  $f_m=1\text{ kHz}$ )

Characteristics		Symbol	Test Condition	Min.	Typ.	Max.	Unit
Supply Current		I <sub>CC</sub> (FM)	V <sub>in</sub> =0, FM mode	--	9	12.5	mA
		I <sub>CC</sub> (AM)	V <sub>in</sub> =0, AM mode	--	5	7.5	
F/E	Input Limiting Voltage	V <sub>in</sub> (lim)	-3dB limiting	--	7	--	dB $\mu$ V EMF
	Local OSC Voltage	V <sub>osc</sub>	F <sub>osc</sub> =108.7MHz	--	105	--	mV <sub>rms</sub>
FM IF	Input Limiting Voltage	V <sub>in</sub> (lim) IF	-3dB limiting	35	40	45	dB $\mu$ V EMF
	Recovered Output Voltage	V <sub>OD</sub>	V <sub>in</sub> =80dB $\mu$ V EMF	90	105	120	mV <sub>rms</sub>
	Signal To Noise Ratio	S/N	V <sub>in</sub> =80dB $\mu$ V EMF	--	65	--	dB
	Total Harmonic Distortion	THD	V <sub>in</sub> =80dB $\mu$ V EMF	--	0.2	--	%
	AM Rejection Ration	AMR	V <sub>in</sub> =80dB $\mu$ V EMF	--	50	--	Db
	LED On Sensitivity	V <sub>L</sub>	I <sub>L</sub> =1mA	40	45	50	dB $\mu$ V EMF
Soft Mute Attenuation		MUTE	V <sub>in</sub> =0	--	20	--	dB
AM	Gain	GV	V <sub>in</sub> =25dB $\mu$ V EMF	18	35	70	mV <sub>rms</sub>
	Recovered Output Voltage	V <sub>OD</sub>	V <sub>in</sub> =60dB $\mu$ V EMF	50	70	90	mV <sub>rms</sub>
	Signal To Noise Ratio	S/N	V <sub>in</sub> =60dB $\mu$ V EMF	--	41	--	dB
	Total Harmonic Distortion	THD	V <sub>in</sub> =60dB $\mu$ V EMF	--	0.7	--	%
	LED On Sensitivity	V <sub>L</sub>	I <sub>L</sub> =1mA	23	28	33	dB $\mu$ V EMF
Pin (18) Output Resistance		R <sub>18</sub>	FM mode	--	0.75	--	k $\Omega$
			AM mode	--	15.5	--	
MPX	Input Resistance	R <sub>IN</sub>	--	--	55	--	k $\Omega$
	Output Resistance	R <sub>OUT</sub>	--	--	5	--	k $\Omega$
	Max. Composite Signal Input Voltage	V <sub>in</sub> MAX (STEREO)	L+R=90%, P=10%, $f_m=1\text{KHz}$ , THD=3%	--	700	--	mV <sub>rms</sub>

(To be continued)

(Continued)

Characteristics		Symbol	Test Condition	Min.	Typ.	Max.	Unit	
MPX	Separation	Sep	L+R=180mV <sub>rms</sub> , P=20mV <sub>rms</sub>	fm=100Hz	--	45	--	dB
				fm=1kHz	35	45	--	
				fm=10kHz	--	45	--	
MPX	Total Harmonic Distortion	Monaural	THD (MONAURAL) V <sub>in</sub> =200mV <sub>rms</sub>	--	0.3	--	%	
		Stereo	THD (STEREO) L+R=180mV <sub>rms</sub> , P=20mV <sub>rms</sub>	--	0.3	--		
MPX	Voltage Gain		GV	V <sub>in</sub> =200mV <sub>rms</sub>	-2.5	-1	0.5	dB
	Channel Balance		C.B.	V <sub>in</sub> =200mV <sub>rms</sub>	-1.5	0	1.5	dB
	Stereo LED Sensitivity	ON	V <sub>L</sub> (ON)	Pilot input	--	8	12	mV <sub>rms</sub>
		OFF	V <sub>L</sub> (OFF)		3	6	--	
	Stereo LED Hysteresis		V <sub>H</sub>	To LED turn off from LED turn on	--	2	--	mV <sub>rms</sub>
	Capture Range		C.R.	P=20mV <sub>rms</sub>	--	±8	--	%
	Signal To Noise Ratio		S/N	--	--	80	--	dB

### PIN CONFIGURATION

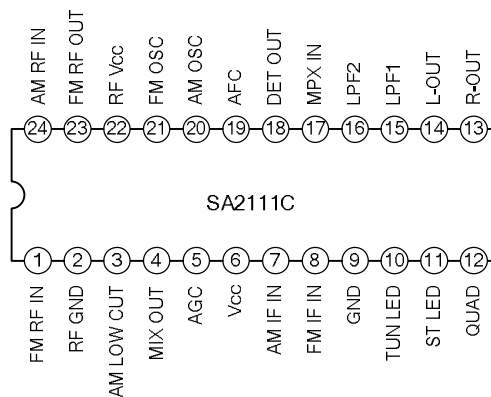

www.DataSheet4U.com

### PIN DESCRIPTION

Pin No.	Symbol	Description
1	FM-RF IN	FM-RF INPUT
2	RF GND	GND for FM RF, FM OSC stage
3	AM LOW CUT	AM LOW FREQUENCY CUT DOWN
4	MIX OUT	FM & AM MIX OUTPUT
5	AGC	AUTOMATIC GAIN CONTROL
6	Vcc	VCC for AM, FM IF, FM MPX stage
7	AM IF IN	AM IF INPUT

(To be continued)

(Continued)

Pin No.	Symbol	Description
8	FM IF IN	FM IF INPUT
9	GND	GND for AM, FM IF, FM MPX stage
10	TUN LED	tuning LED
11	ST LED	Stereo LED
12	QUAD	FM QUAD. Detector
13	R-OUT	R-channel Output
14	L-OUT	L-channel Output
15	LPF1	<ul style="list-style-type: none"> <li>• LPF terminal for synchronous detector</li> <li>• VCO stop terminal V15=VCC→VCO STOP</li> </ul>
16	LPF2	<ul style="list-style-type: none"> <li>• LPF terminal for phase detector</li> <li>• Bias terminal for AM/FM SW circuit</li> </ul> V16=VCC→AM V16=OPEN→FM
17	MPX IN	MPX INPUT
18	DET OUT	FM & AM DETECT OUTPUT
19	AFC	AUTO FREQUENCY CONTROL
20	AM OSC	AM OSC
21	FM OSC	FM OSC
22	RF Vcc	VCC for FM OSC stage
23	FM RF OUT	FM RF OUTPUT
24	AM RF IN	AM RF INPUT

## FUNCTION DESCRIPTION

Application note:

www.DataSheet4U.com

### 1. AM low-cut circuit

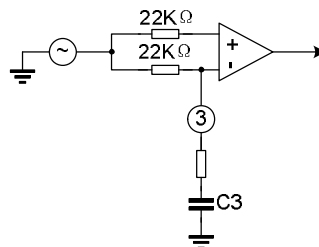

When pin3 is open, no AF signal can pass through the AMP stage because of the common mode.

When the value of C3 that connected to pin3 is over 1uF, all AF signal can pass through the AMP stage.

The cut-off frequency  $f_L$  is determined by the internal resistance 22kΩ (Typ.) and the external capacitor C3 as below:

$$f_L = \frac{1}{2 \times \pi \times 22 \times 10^3 \times C3} \text{ (Hz)}$$

It is possible to reduce the recovered output level at AM mode, by additional resistance between the pin (3) and GND line.

2. FM detection circuit

The detection coil can take replace the ceramic discriminator in the FM detection circuit. Recommended circuit and recommended coil are as follows. In this case, please take care that  $V_{in} (lim)$  falls a little.

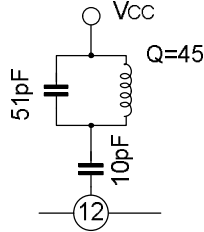

TEST CIRCUIT (1)

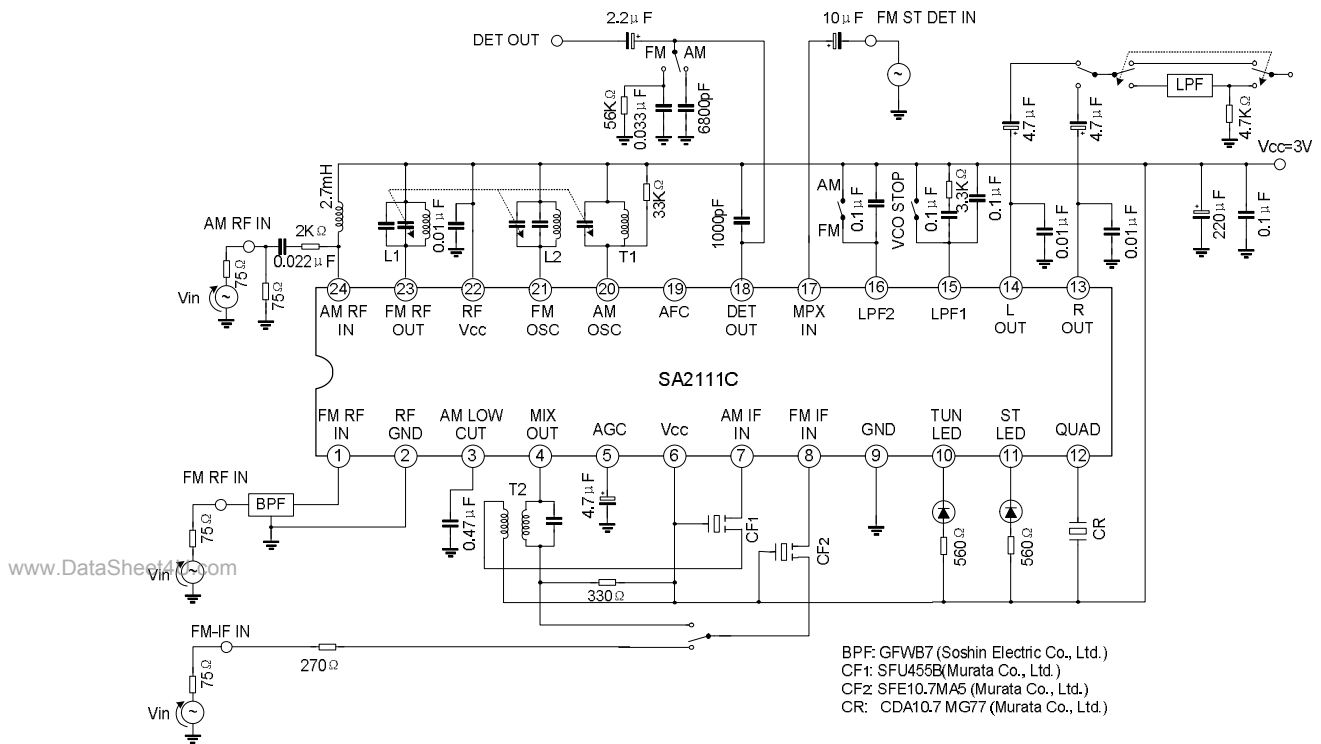

TEST CIRCUIT (2)

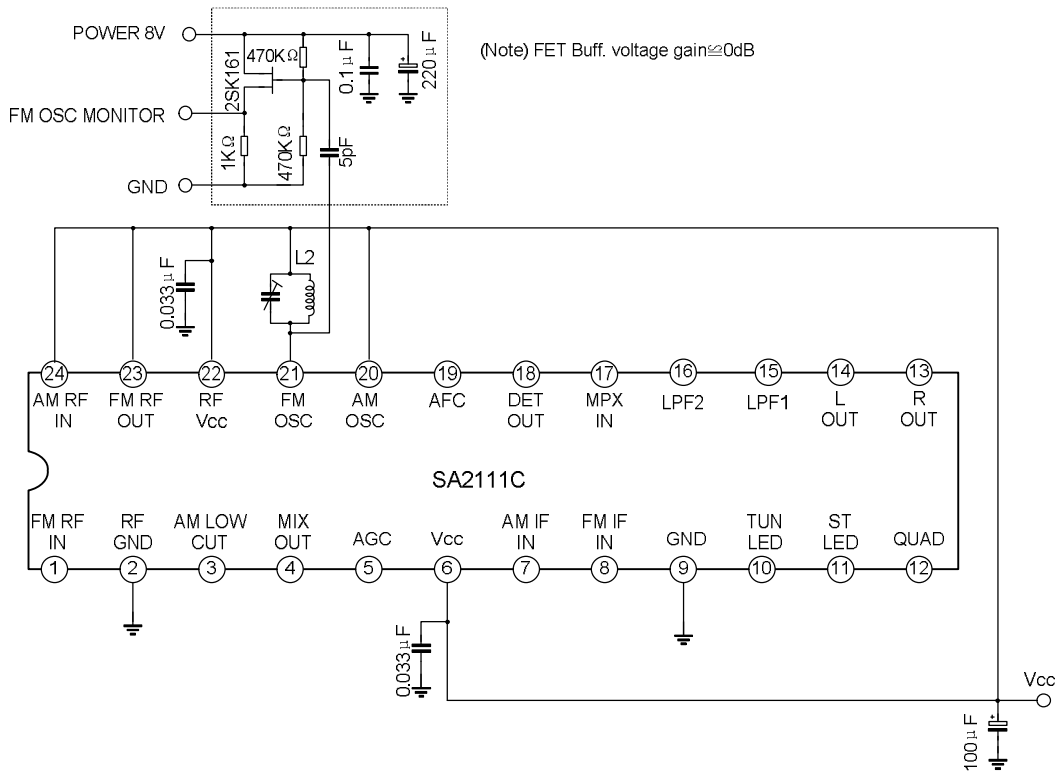

COIL DATA

Coil No.	Test Freq.	L ( $\mu\text{H}$ )	Co (Pf)	Qo	Turns					Wire (mm $\varnothing$ )	Reference
					1-2	2-3	1-3	1-4	4-6		
L1 FM RF	100MHz	--	--	79	--	--	--	2 $\frac{1}{2}$	--	0.16UEW	Toko Co., Ltd. 666SNF-305NK
L2 FM OSC	100MHz	--	--	76	--	--	--	2	--	0.16UEW	Toko Co., Ltd. 666SNF-306NK
T1 AM OSC	796kHz	268	--	65	19	95	--	--	--	0.05UEW	Toko Co., Ltd. 5PNR-5146Y
T2 AM IFT	455kHz	--	470	60	--	--	109	--	7	0.05UEW	Toko Co., Ltd. 5PNR-5147Y

L1: FM RF

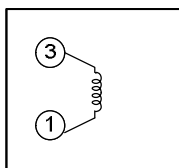

L2: FM OSC

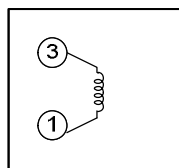

T1: AM OSC

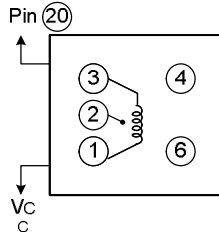

T2: AM IF

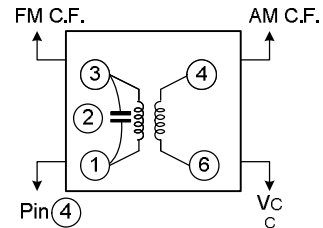



PACKAGE OUTLINE

SDIP-24-300-1.778

UNIT: mm

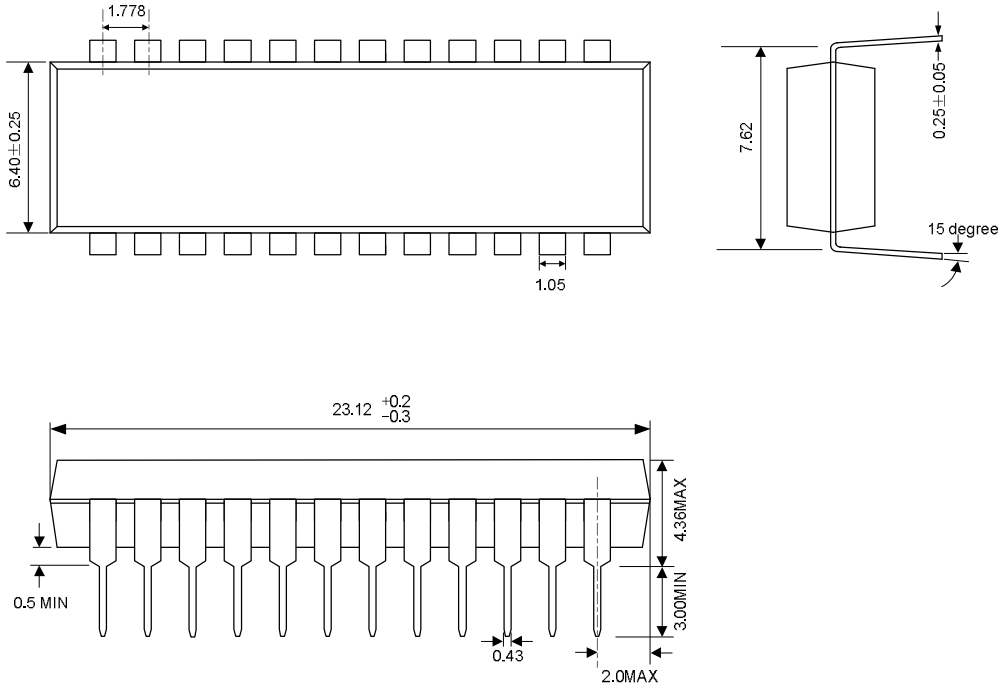

SSOP-24-300-0.65

UNIT: mm

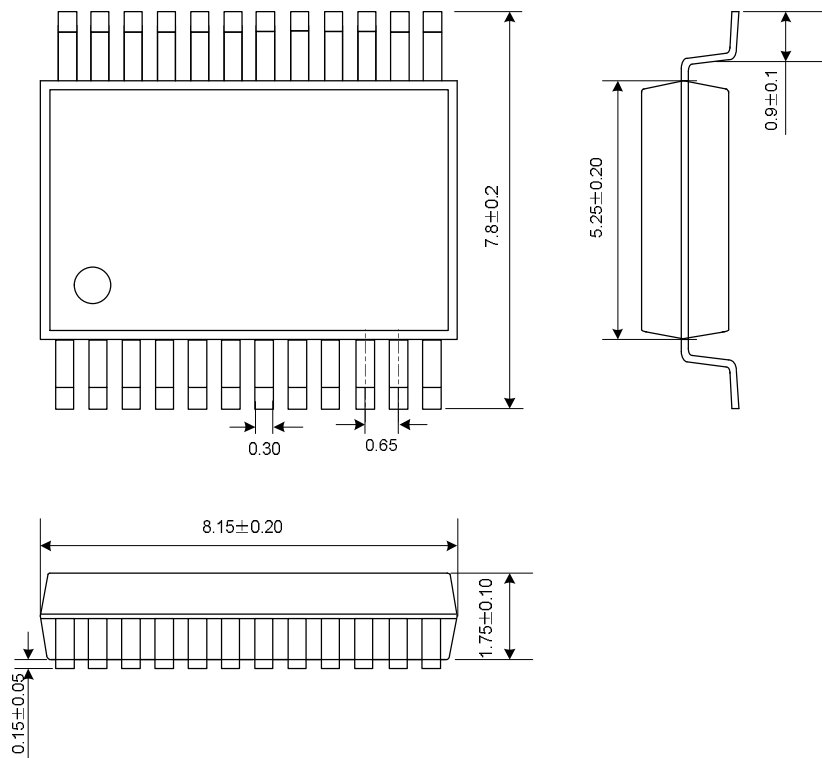

www.DataSheet4U.com



PACKAGE OUTLINE (Continued)

SOP-24-375-1.27

UNIT: mm

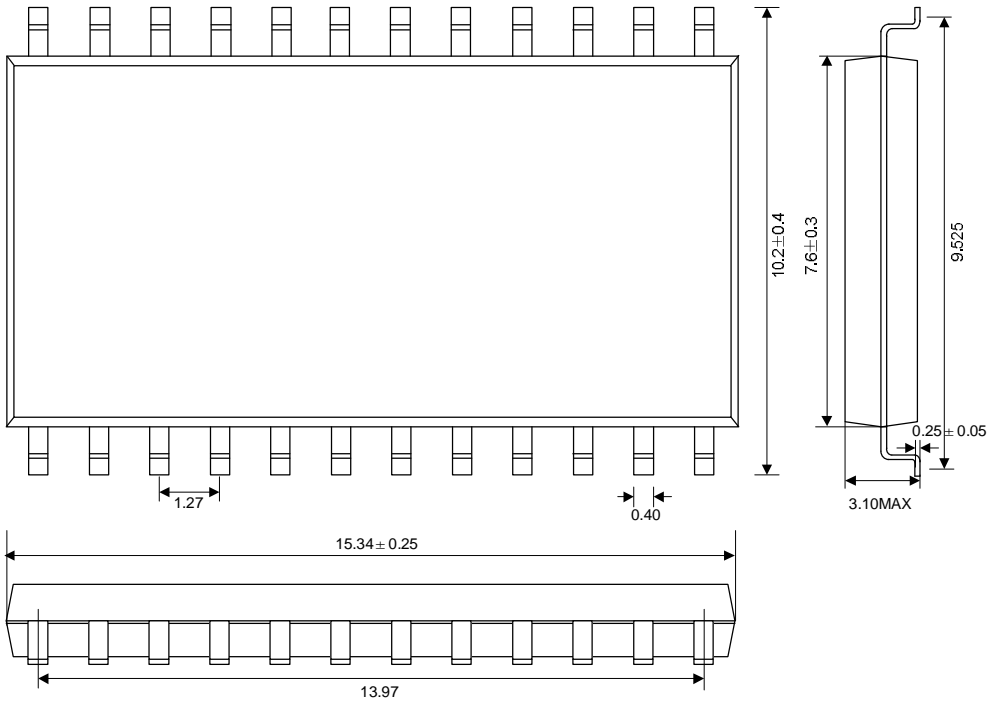

SSOP-24-300-1.0

UNIT: mm

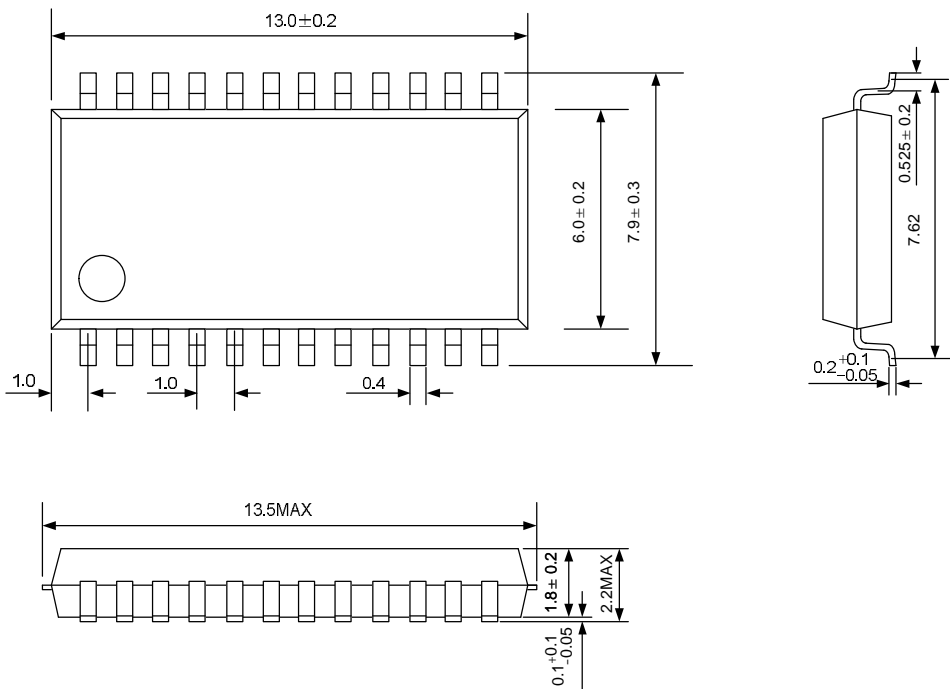

www.DataSheet4U.com