

PNP general purpose transistors

BC556; BC557

FEATURES

- Low current (max. 100 mA)
- Low voltage (max. 65 V).

APPLICATIONS

- General purpose switching and amplification.

DESCRIPTION

PNP transistor in a TO-92; SOT54 plastic package.
NPN complements: BC546 and BC547.

PINNING

PIN	DESCRIPTION
1	emitter
2	base
3	collector

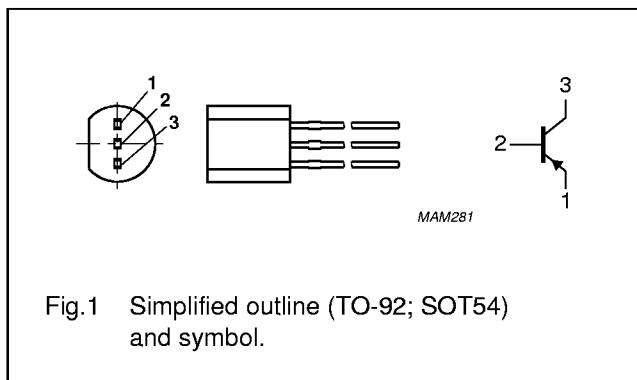

LIMITING VALUES

In accordance with the Absolute Maximum Rating System (IEC 134).

SYMBOL	PARAMETER	CONDITIONS	MIN.	MAX.	UNIT
V _{CBO}	collector-base voltage	open emitter			
	BC556		–	–80	V
	BC557		–	–50	V
V _{CEO}	collector-emitter voltage	open base			
	BC556		–	–65	V
	BC557		–	–45	V
V _{EBO}	emitter-base voltage	open collector	–	–5	V
I _C	collector current (DC)		–	–100	mA
I _{CM}	peak collector current		–	–200	mA
I _{BM}	peak base current		–	–200	mA
P _{tot}	total power dissipation	T _{amb} ≤ 25 °C	–	500	mW
T _{stg}	storage temperature		–65	+150	°C
T _j	junction temperature		–	150	°C
T _{amb}	operating ambient temperature		–65	+150	°C

PNP general purpose transistors

BC556; BC557

THERMAL CHARACTERISTICS

SYMBOL	PARAMETER	CONDITIONS	VALUE	UNIT
$R_{th\ j-a}$	thermal resistance from junction to ambient	note 1	250	K/W

Note

1. Transistor mounted on an FR4 printed-circuit board.

CHARACTERISTICS

$T_j = 25\text{ °C}$ unless otherwise specified.

SYMBOL	PARAMETER	CONDITIONS	MIN.	TYP.	MAX.	UNIT
I_{CBO}	collector cut-off current	$I_E = 0; V_{CB} = -30\text{ V}$	–	–1	–15	nA
		$I_E = 0; V_{CB} = -30\text{ V}; T_j = 150\text{ °C}$	–	–	–4	μA
I_{EBO}	emitter cut-off current	$I_C = 0; V_{EB} = -5\text{ V}$	–	–	–100	nA
h_{FE}	DC current gain BC556 BC557 BC556A BC556B; BC557B BC557C	$I_C = -2\text{ mA}; V_{CE} = -5\text{ V};$ see Figs 2, 3 and 4	125	–	475	
			125	–	800	
			125	–	250	
			220	–	475	
			420	–	800	
V_{CEsat}	collector-emitter saturation voltage	$I_C = -10\text{ mA}; I_B = -0.5\text{ mA}$	–	–60	–300	mV
		$I_C = -100\text{ mA}; I_B = -5\text{ mA}$	–	–180	–650	mV
V_{BEsat}	base-emitter saturation voltage	$I_C = -10\text{ mA}; I_B = -0.5\text{ mA};$ note 1	–	–750	–	mV
		$I_C = -100\text{ mA}; I_B = -5\text{ mA};$ note 1	–	–930	–	mV
V_{BE}	base-emitter voltage	$I_C = -2\text{ mA}; V_{CE} = -5\text{ V};$ note 2	–600	–650	–750	mV
		$I_C = -10\text{ mA}; V_{CE} = -5\text{ V};$ note 2	–	–	–820	mV
C_c	collector capacitance	$I_E = I_E = 0; V_{CB} = -10\text{ V}; f = 1\text{ MHz}$	–	3	–	pF
C_e	emitter capacitance	$I_C = I_C = 0; V_{EB} = -0.5\text{ V}; f = 1\text{ MHz}$	–	10	–	pF
f_T	transition frequency	$I_C = -10\text{ mA}; V_{CE} = -5\text{ V}; f = 100\text{ MHz}$	100	–	–	MHz
F	noise figure	$I_C = -200\text{ }\mu\text{A}; V_{CE} = -5\text{ V}; R_S = 2\text{ k}\Omega;$ $f = 1\text{ kHz}; B = 200\text{ Hz}$	–	2	10	dB

Notes

1. V_{BEsat} decreases by about -1.7 mV/K with increasing temperature.
2. V_{BE} decreases by about -2 mV/K with increasing temperature.

PNP general purpose transistors

BC556; BC557

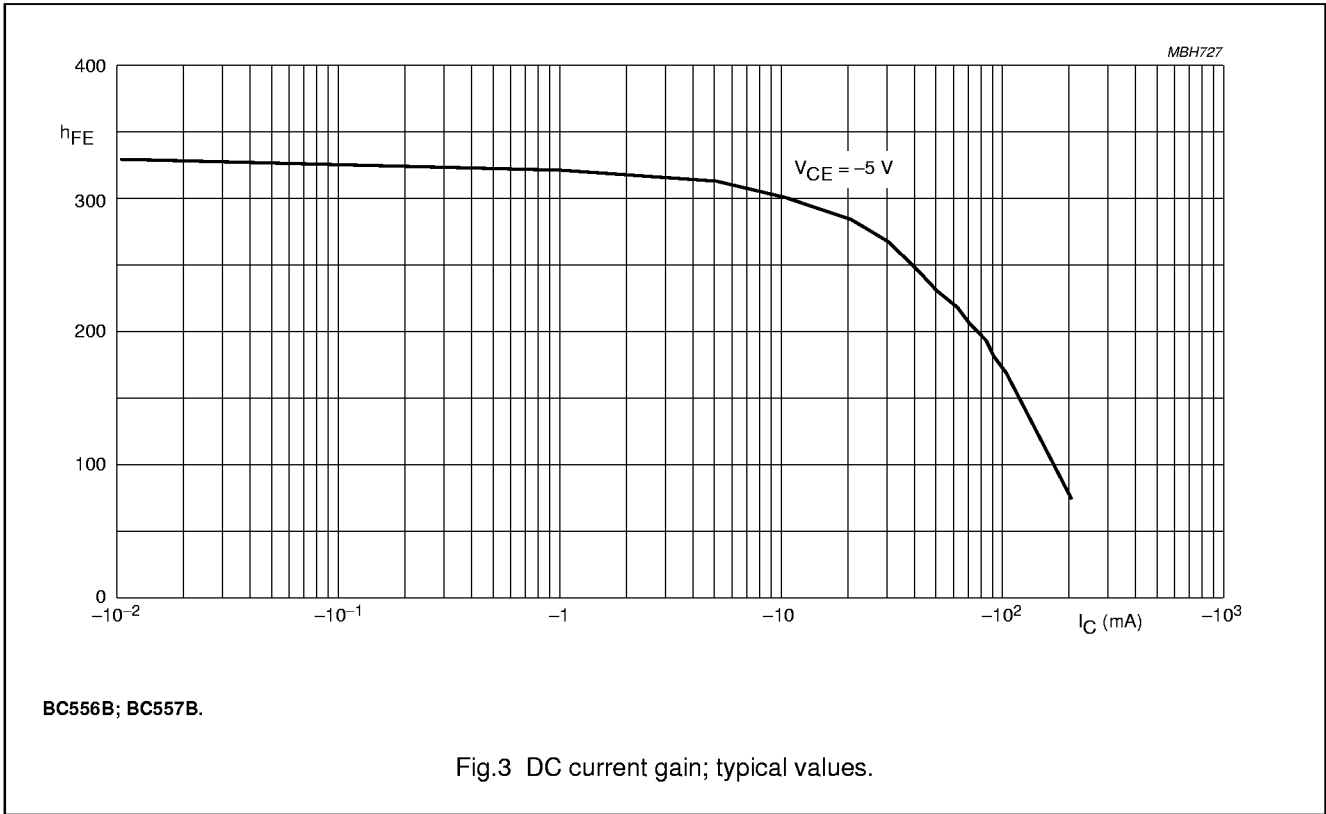
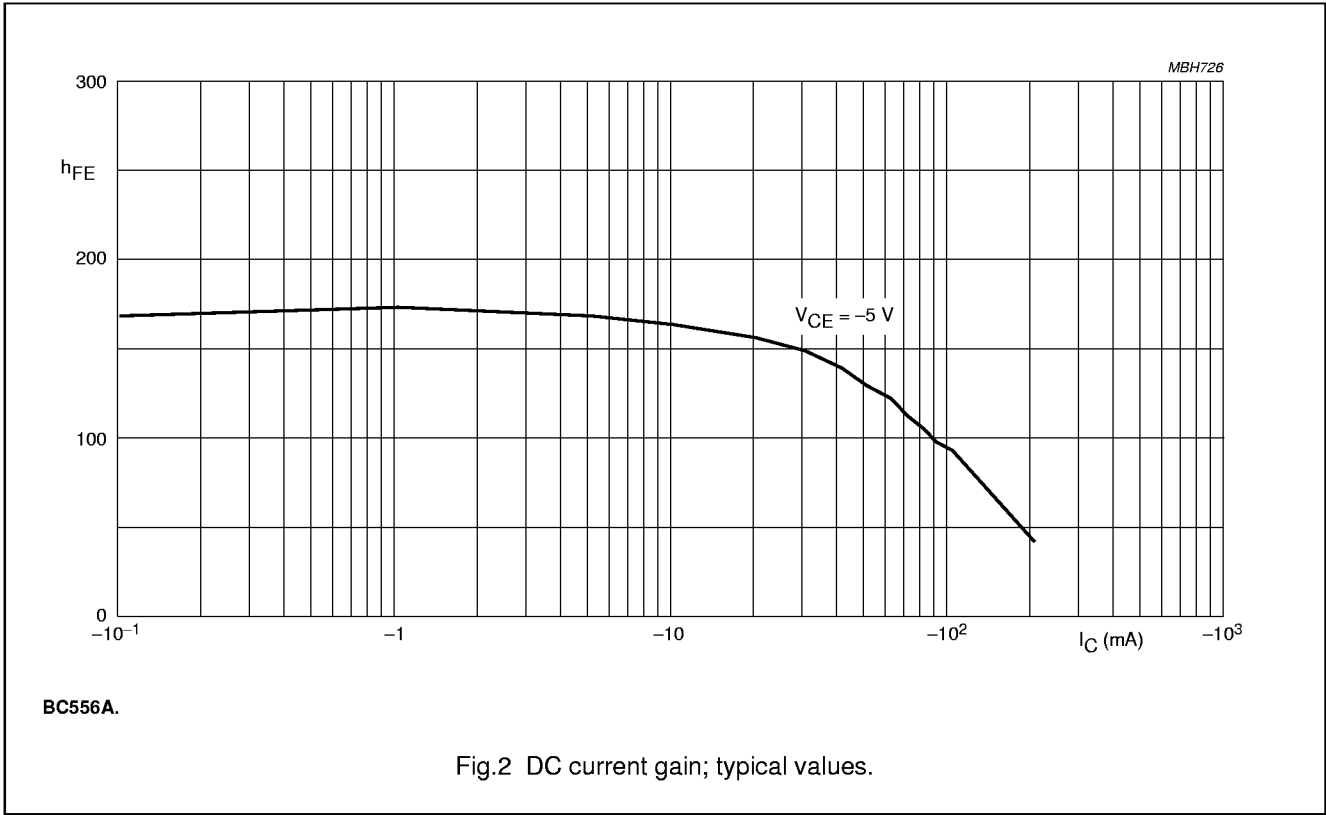

PNP general purpose transistors

BC556; BC557

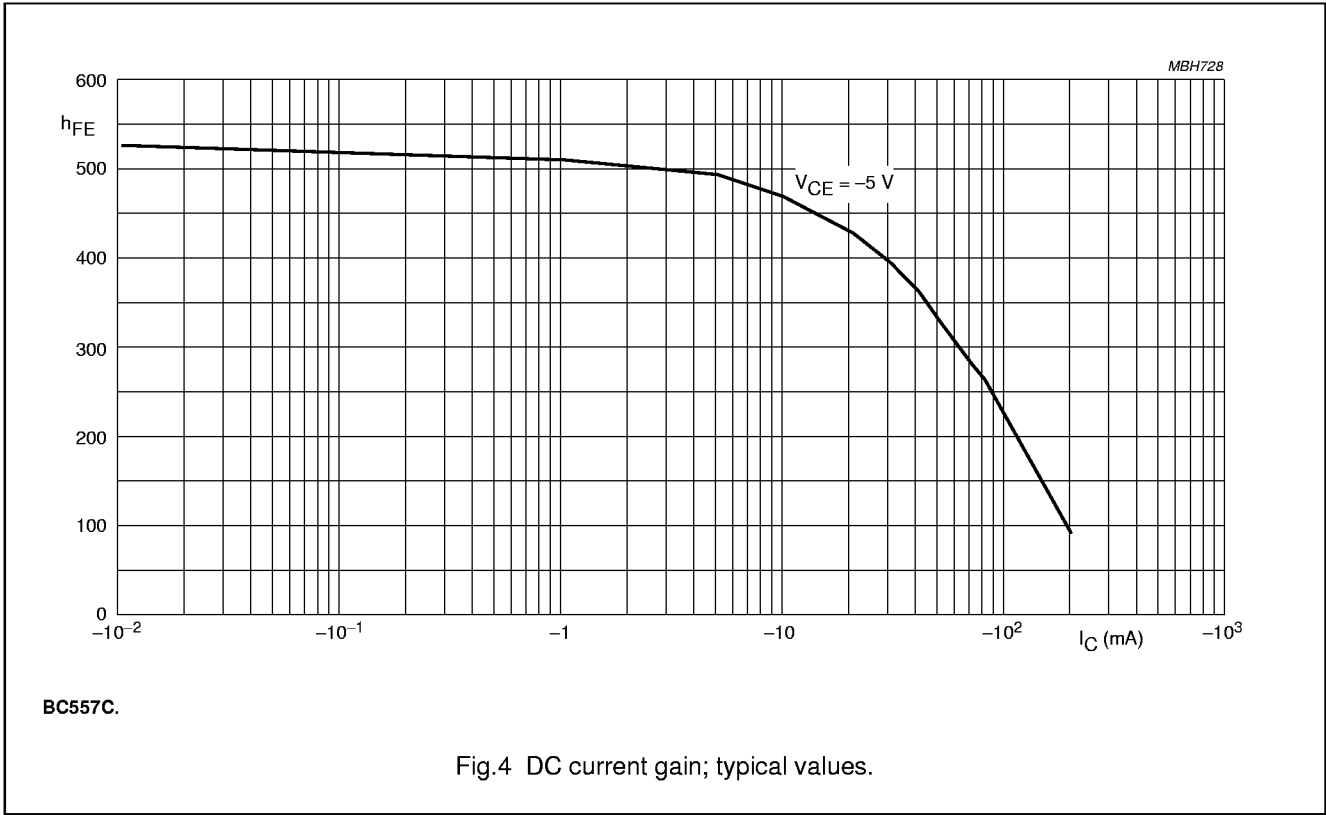

PNP general purpose transistors

BC556; BC557

PACKAGE OUTLINE

Plastic single-ended leaded (through hole) package; 3 leads

SOT54

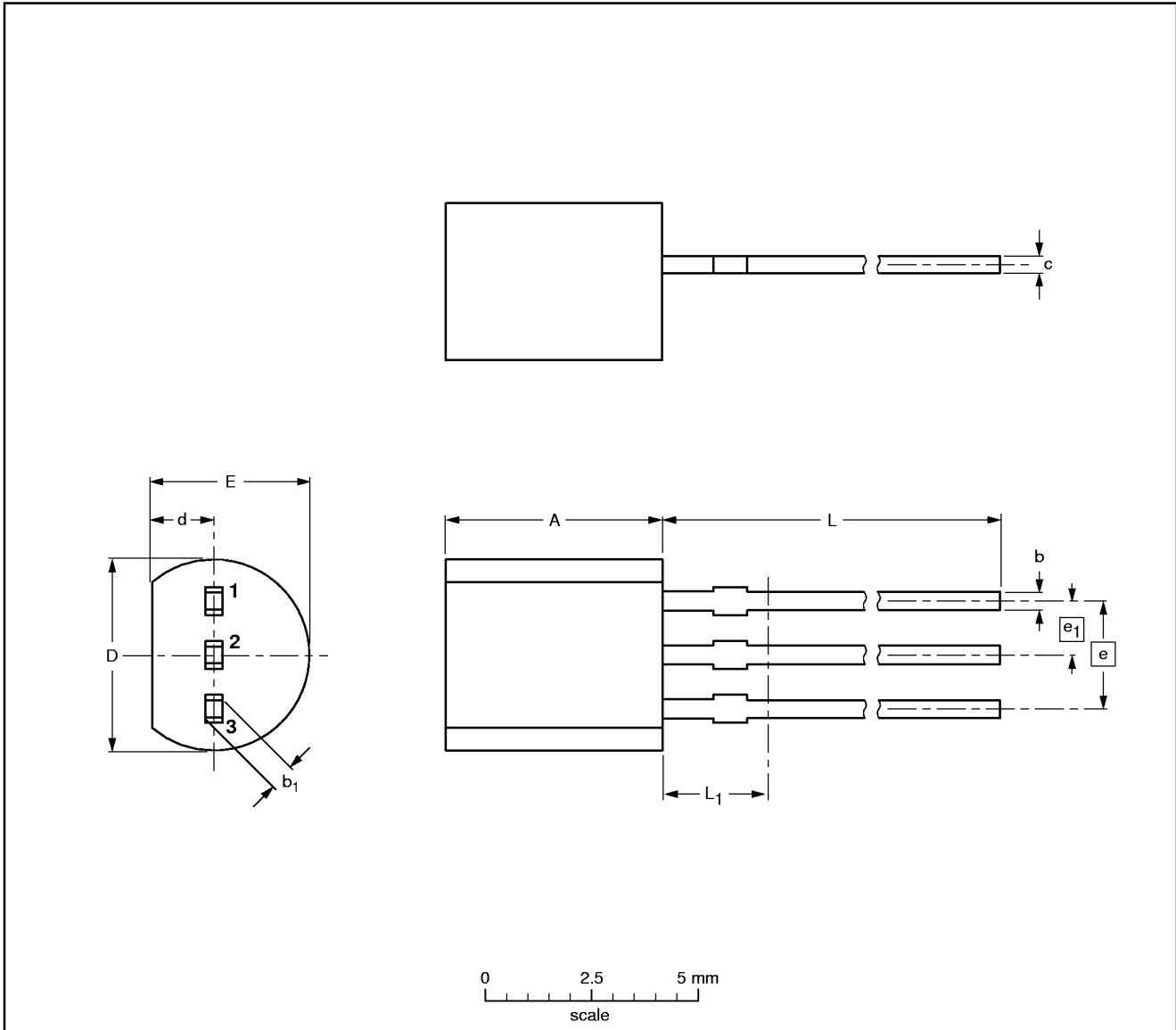

DIMENSIONS (mm are the original dimensions)

UNIT	A	b	b ₁	c	D	d	E	e	e ₁	L	L ₁ (¹)
mm	5.2 5.0	0.48 0.40	0.66 0.56	0.45 0.40	4.8 4.4	1.7 1.4	4.2 3.6	2.54	1.27	14.5 12.7	2.5

Note

1. Terminal dimensions within this zone are uncontrolled to allow for flow of plastic and terminal irregularities.

OUTLINE VERSION	REFERENCES			EUROPEAN PROJECTION	ISSUE DATE
	IEC	JEDEC	EIAJ		
SOT54		TO-92	SC-43		97-02-28