

- Structure : Silicon Monolithic Integrated Circuit
- Product Series : Power Driver for Compact disc player
- type : **BD8222EFV**
- Feature :
 - 4CH BTL Driver.
 - Employs the HTSSOP-B24PIN power package for compaction.
 - Has a wide dynamic range. (PowVcc1=8V, RL=8Ω, 6.0V (typ.))
 - The thermal shutdown circuit contained.
 - Switches CH2 input by Control input terminal(CNT).
 - Incorporates mute function by CNT terminal and mute terminal.

Absolute maximum ratings(Ta=25)

Parameter	Symbol	Limits	Unit
Power supply voltage	PowVcc 1,PowVcc 2	15	V
Input terminal	BIAS1, BIAS2, LDIN, SLIN, IN1, IN3, IN4	PowVcc 2	V
CNT terminal	CNT	PowVcc 2	V
MUTE terminal	MUTE1,2, 3 4	PowVcc 2	V
BIASSW terminal	BIASSW	PowVcc 2	V
Power dissipation	Pd	1.1*1	W
		4.0*2	
Operating temperature range	Topr	-40 ~ +85	
Storage temperature	Tstg	-55 ~ +150	
Junction temperature	Tjmax	+150	

*1 70mm×70mm×1.6mm, occupied copper foil is less than 3%,one layer substrate(back copper foil 0mm×0mm)
Reduce power by 8.8mW for each degree above 25 .

*2 70mm×70mm×1.6mm, occupied copper foil is less than 3%,four layer substrate(back copper foil 70mm×70mm)
Reduce power by 32.0mW for each degree above 25 .

Operating conditions

(Set the power supply voltage taking allowable dissipation into considering.)

PowVcc 1,2	4.5 ~ 10 (V)
------------	----------------

Please use it with PowVcc 1= PowVcc 2

Status of this document

The Japanese version of this document is the formal specification. A customer may use this translation version only for a reference to help reading the formal version. If there are any differences in translation version of this document, formal version takes priority.

Be careful to handle because the content of the description of this material might correspond to the labor (technology in the design, manufacturing, and use) in foreign country exchange and Foreign Trade Control Law.

A radiation is not designed.

Electrical characteristics (Unless otherwise noted, Ta=25 , PowVcc1=PowVcc2=8V, BIAS=1.65V, RL=8)

Parameter	Symbol	MIN	TYP	MAX	Unit	Condition
Quiescent dissipation current	IQ	-	30	45	mA	At no-load
< Driver >						
Output offset voltage (CH1,2)	V _{oof1}	-100	0	100	mV	
Output offset voltage (CH3,4)	V _{oof2}	-50	0	50	mV	
Maximum output amplitude (CH1,2)	VOM1	5.4	6.0	-	V	
Maximum output amplitude (CH3,4)	VOM2	4.7	5.3	-	V	
Closed circuit voltage gain (CH1,2)	G _{vc1}	24.0	25.7	27.4	dB	VIN=±0.3V
Closed circuit voltage gain (CH3,4)	G _{vc2}	15.5	17.5	19.5	dB	VIN=±0.3V
Input impedance (CH1,2)	ZIN1	13	20	27	kΩ	PIN21,22,24
Input impedance (CH3,4)	ZIN2	31	47	63	kΩ	PIN18,19
LD Internal reference voltage 1	INLDV1	1.52	1.65	1.78	V	PIN20=H
LD Internal reference voltage 2	INLDV2	2.30	2.50	2.70	V	PIN20=L
< Each function terminal >						
MUTE terminal low level input voltage	VML	-	-	0.5	V	PIN13,14,15
MUTE terminal high level input voltage	VMH	2.0	-	-	V	"
CNT terminal low level input voltage	VCNTL	-	-	0.5	V	
CNT terminal high level input voltage	VCNTH	2.0	-	-	V	
BIASSW terminal low level input voltage	VBSL	-	-	0.5	V	
BIASSW terminal high level input voltage	VBSH	2.0	-	-	V	
MUTE2 terminal low level input current	IMTL	-15	0	15	μA	PIN14=0V
MUTE2 terminal high level input current	IMTH	-	85	170	μA	PIN14=5V
MUTE134 terminal low level input current	IMTL	-15	0	15	μA	PIN13=0V
MUTE134 terminal high level input current	IMTH	-	180	360	μA	PIN13=5V
CNT terminal low level input current	ICNTL	-15	0	15	μA	PIN23=0V
CNT terminal high level input current	ICNTH	-	85	170	μA	PIN23=5V
BIASSW terminal low level input current	IBSL	-15	0	15	μA	PIN20=0V
BIASSW terminal high level input current	IBSH	-	85	170	μA	PIN20=5V
BIAS input terminal input current	IB1	-	52	104	μA	PIN17=1.65V

VIN : IN1, SLIN, IN3, and the IN4 voltage are the BIAS voltages.

LDIN : 1.65V + 0.05V、1.65V + 0.15V (LD Internal reference voltage 1.65V (typ.))
 2.5V + 0.05V、2.5V + 0.15V (LD Internal reference voltage 2.5V (typ.))

Package outlines : HTSSOP-B24

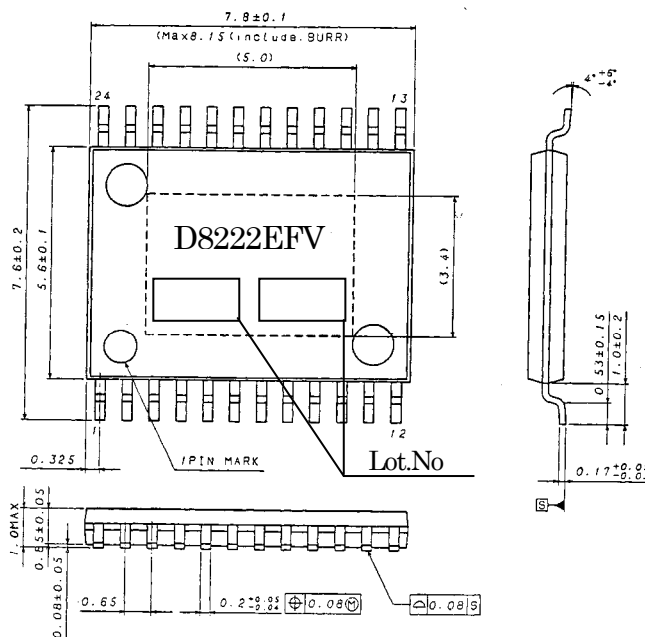

HTSSOP-B24(UNIT : mm)

Block diagram

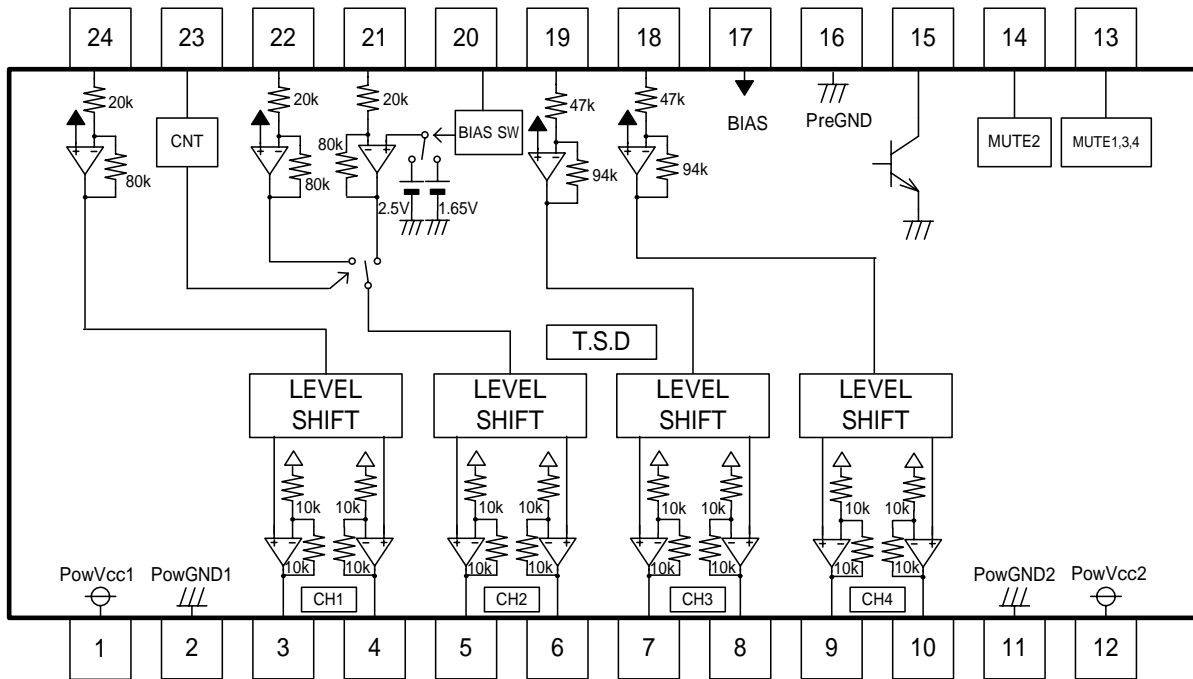

T.S.D : Thermal Shut-Down

Pin description

No.	Symbol	Description	No.	Symbol	Description
1	PowVcc1	CH1,2 power supply terminal	13	MUTE1,3,4	MUTE 1,3,4 terminal
2	PowGND	Power GND	14	MUTE2	MUTE 2 terminal
3	VO1(-)	Driver CH1 negative output	15	T _b	TEST OUT terminal
4	VO1(+)	Driver CH1 positive output	16	PreGND	PreGND
5	VO2(-)	Driver CH2 negative output	17	BIAS	BIAS input
6	VO2(+)	Driver CH2 positive output	18	IN4	CH4 input
7	VO3(-)	Driver CH3 negative output	19	IN3	CH3 input
8	VO3(+)	Driver CH3 positive output	20	BIASSW	LD Reference voltage switch terminal
9	VO4(-)	Driver CH4 negative output	21	LDIN	LD input
10	VO4(+)	Driver CH4 positive output	22	SLIN	SL input
11	PowGND	Power GND	23	CNT	Control input terminal
12	PowVcc2	Pre Block and CH3,4 power supply terminal	24	IN1	IN1 input

Cautions in using the IC

1. Absolute maximum ratings

We are careful enough for quality control about this IC. So, there is no problem under normal operation, excluding that it exceeds the absolute maximum ratings. However, this IC might be destroyed when the absolute maximum ratings, such as impressed voltages or the operating temperature range, is exceeded, and whether the destruction is short circuit mode or open circuit mode cannot be specified. Please take into consideration the physical countermeasures for safety, such as fusing, if a particular mode that exceeds the absolute maximum rating is assumed.

2. Reverse polarity connection

Connecting the power line to the IC in reverse polarity (from that recommended) will damage the part. Please utilize the direction protection device as a diode in the supply line and motor coil line.

3. Power supply line

Due to return of regenerative current by reverse electromotive force, using electrolytic and ceramic suppress filter capacitors (0.1μF) close to the IC power input terminals (Vcc and GND) are recommended. Please note the electrolytic capacitor value decreases at lower temperatures and examine to dispense physical measures for safety. And, for ICs with more than one power supply, it is possible that rush current may flow instantaneously due to the internal powering sequence and delays. Therefore, give special consideration to power coupling capacitance, power wiring, width of GND wiring, and routing of wiring.

4. GND line

Please keep the GND line the lowest potential always, and check the GND voltage when transient voltages are connected to the IC.

5. Thermal design

Do not exceed the power dissipation (Pd) of the package specification rating under actual operation, and please design enough temperature margins. This product has exposed the frame to the back side of the package, but please note that it is assumed to use heat radiation efficiency by the heat radiation for this part. Please take the heat radiation pattern on not only the surface of the substrate but also the back of the substrate widely.

6. Short circuit mode between terminals and wrong mounting

Do not mount the IC in the wrong direction and displacement, and be careful about the reverse connection of the power connector. Moreover, this IC might be destroyed when the dust short the terminals between them or GND.

7. Radiation

Strong electromagnetic radiation can cause operation failures.

8. ASO (Area of Safety Operation)

Do not exceed the maximum ASO and the absolute maximum ratings of the output driver.

9. TSD (Thermal Shut-Down)

The TSD is activated when the junction temperature (Tj) exceeds Tjmax, and the output terminal is switched to OPEN. The guarantee and protection of set are not purpose. Therefore, please do not use this IC after TSD circuit operates, nor use it for assumption that operates the TSD circuit.

10. Capacitor between output driver and GND

If a large capacitor is connected between the output driver and GND, this IC might be destroyed when Vcc becomes 0V or GND, because the electric charge accumulated in the capacitor flows to the output driver. Please set said capacitor to smaller than 0.1μF.

11. Inspection by the set circuit board

The stress might hang to IC by connecting the capacitor to the terminal with low impedance. Then, please discharge electricity in each and all process. Moreover, when attaching or detaching from jig in the inspection process, please turn off the power before mounting the IC, and turn on after mounting the IC, and vice versa. In addition, please take into consideration the countermeasures for electrostatic damage, such as giving the earth in assembly process, transportation or preservation.

12. Input terminal

This IC is a monolithic IC, and has P+ isolation and P substrate for the element separation. Therefore, a parasitic PN junction is formed in this P-layer and N-layer of each element. For instance, the resistor or the transistor is connected to the terminal as shown in the figure below. When the GND voltage potential is greater than the voltage potential at Terminal A on the resistor, at Terminal B on the transistor, the PN junction operates as a parasitic diode. In addition, the parasitic NPN transistor is formed in said parasitic diode and the N layer of surrounding elements close to said parasitic diode. These parasitic elements are formed in the IC because of the voltage relation. The parasitic element operating causes the interference of circuit operation, then the wrong operation and destruction. Therefore, please be careful so as not to operate the parasitic elements by impressing to input terminals lower voltage than GND (P substrate). Please do not apply the voltage to the input terminal when the power-supply voltage is not impressed. Moreover, please impress each input terminal lower than the power-supply voltage or equal to the specified range in the guaranteed voltage when the power-supply voltage is impressing.

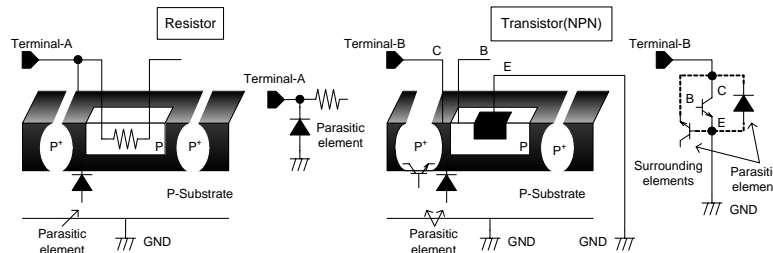

Simplified structure of IC

13. Earth wiring pattern

If small signal GND and large current GND exist, disperse their pattern. In addition, for voltage change by pattern wiring impedance and large current not to change voltage of small signal GND, each ground terminal of IC must be connected at the one point on the set circuit board. As for GND of external parts, it is similar to the above-mentioned.

Notes

- No technical content pages of this document may be reproduced in any form or transmitted by any means without prior permission of ROHM CO.,LTD.
- The contents described herein are subject to change without notice. The specifications for the product described in this document are for reference only. Upon actual use, therefore, please request that specifications to be separately delivered.
- Application circuit diagrams and circuit constants contained herein are shown as examples of standard use and operation. Please pay careful attention to the peripheral conditions when designing circuits and deciding upon circuit constants in the set.
- Any data, including, but not limited to application circuit diagrams information, described herein are intended only as illustrations of such devices and not as the specifications for such devices. ROHM CO.,LTD. disclaims any warranty that any use of such devices shall be free from infringement of any third party's intellectual property rights or other proprietary rights, and further, assumes no liability of whatsoever nature in the event of any such infringement, or arising from or connected with or related to the use of such devices.
- Upon the sale of any such devices, other than for buyer's right to use such devices itself, resell or otherwise dispose of the same, no express or implied right or license to practice or commercially exploit any intellectual property rights or other proprietary rights owned or controlled by
- ROHM CO., LTD. is granted to any such buyer.
- Products listed in this document are no antiradiation design.

The products listed in this document are designed to be used with ordinary electronic equipment or devices (such as audio visual equipment, office-automation equipment, communications devices, electrical appliances and electronic toys).

Should you intend to use these products with equipment or devices which require an extremely high level of reliability and the malfunction of which would directly endanger human life (such as medical instruments, transportation equipment, aerospace machinery, nuclear-reactor controllers, fuel controllers and other safety devices), please be sure to consult with our sales representative in advance.

It is our top priority to supply products with the utmost quality and reliability. However, there is always a chance of failure due to unexpected factors. Therefore, please take into account the derating characteristics and allow for sufficient safety features, such as extra margin, anti-flammability, and fail-safe measures when designing in order to prevent possible accidents that may result in bodily harm or fire caused by component failure. ROHM cannot be held responsible for any damages arising from the use of the products under conditions out of the range of the specifications or due to non-compliance with the NOTES specified in this catalog.

Thank you for your accessing to ROHM product informations.

More detail product informations and catalogs are available, please contact your nearest sales office.

ROHM Customer Support System

THE AMERICAS / EUROPE / ASIA / JAPAN

www.rohm.com

Contact us : webmaster@rohm.co.jp