



IBM13M16734BCC

16M x 72 1 Bank Registered/Buffered SDRAM Module

Features

- 168-Pin Registered 8-Byte Dual In-Line Memory Module
- 16Mx72 Synchronous DRAM DIMM
- Performance:

		-10		-260, -360 (PC100)		Units
		Reg.	Buff.	Reg.	Buff.	
DIMM CAS Latency		3	2	3	2	
f _{CK}	Clock Frequency	66	66	100	100	MHz
t _{CK}	Clock Cycle	15	15	10	10	ns
t _{AC}	Clock Access Time	9.7	9.7	7.7	7.7	ns

- Intended for 66/100MHz and PC100 applications
- Inputs and outputs are LVTTTL (3.3V) compatible
- Single 3.3V ± 0.3V Power Supply
- Single Pulsed $\overline{\text{RAS}}$ interface
- SDRAMs have four internal banks
- Module has one physical bank
- Fully Synchronous to positive Clock Edge

- Programmable Operation:
 - DIMM $\overline{\text{CAS}}$ Latency: 3, 4 (Registered mode), 2, 3 (Buffered mode)
 - Burst Type: Sequential or Interleave
 - Burst Length: 1, 2, 4, 8, Full-Page (Full-Page supports Sequential burst only)
 - Operation: Burst Read and Write or Multiple Burst Read with Single Write
- Data Mask for Byte Read/Write control
- Auto Refresh (CBR) and Self Refresh
- Automatic and controlled Precharge Commands
- Suspend Mode and Power Down Mode
- 12/10/2 Addressing (Row/Column/Bank)
- 4096 refresh cycles distributed across 64ms
- Card size: 5.25" x 0.157" x 1.70"
- Gold contacts
- SDRAMs in TSOP - Type II Package
- Serial Presence Detect with Write protect feature

Description

IBM13M16734BCC is a registered 168-Pin Synchronous DRAM Dual In-Line Memory Module (DIMM) organized as a 16Mx72 high-speed memory array. The DIMM uses eighteen 16Mx4 SDRAMs in 400 mil TSOP packages. The DIMM achieves high-speed data-transfer rates of up to 100 MHz by employing a prefetch/pipeline hybrid architecture that synchronizes the output data to a system clock.

The DIMM is intended for use in applications operating from 66MHz to 100 MHz, PC100, memory bus speeds, and/or heavily loaded bus applications. All control and address signals are re-driven through registers/buffers to the SDRAM devices. The DIMM can be operated in either registered mode (REGE pin tied high), where the control/address input signals are latched in the register on one rising clock edge and sent to the SDRAM devices on the following rising clock edge (data access is delayed by one clock), or in buffered mode (REGE pin tied low) where the input signals pass through the register/buffer to the SDRAM devices on the same clock. XTK simulation models of the DIMM are available to determine which mode to design for.

A phase-lock loop (PLL) on the DIMM is used to re-drive the clock signals to both the SDRAM devices and the registers to minimize system clock loading.

(CK0 is connected to the PLL, and CK1, CK2, and CK3 are terminated on the DIMM.) A single clock enable (CKE0) controls all devices on the DIMM, enabling the use of SDRAM power-down modes.

Prior to any access operation, the device $\overline{\text{CAS}}$ latency and burst type/length/operation type must be programmed into the DIMM by address inputs A0-A9 using the mode register set cycle. The DIMM $\overline{\text{CAS}}$ latency when operated in buffered mode is the same as the device $\overline{\text{CAS}}$ latency as specified in the SPD EEPROM. The DIMM $\overline{\text{CAS}}$ latency when operated in registered mode is one clock later due to the address and control signals being clocked to the SDRAM devices.

The DIMM uses serial presence detects implemented via a serial EEPROM using the two-pin IIC protocol. The first 128 bytes of serial PD data are programmed and locked by the DIMM manufacturer. The last 128 bytes are available to the customer and may be write protected by providing a high level to pin 81 on the DIMM. An on-board pulldown resistor keeps this in the write-enable mode.

All IBM 168-pin DIMMs provide a high-performance, flexible 8-byte interface in a 5.25" long space-saving footprint.



IBM13M16734BCC
16M x 72 1 Bank Registered/Buffered SDRAM Module

Card Outline

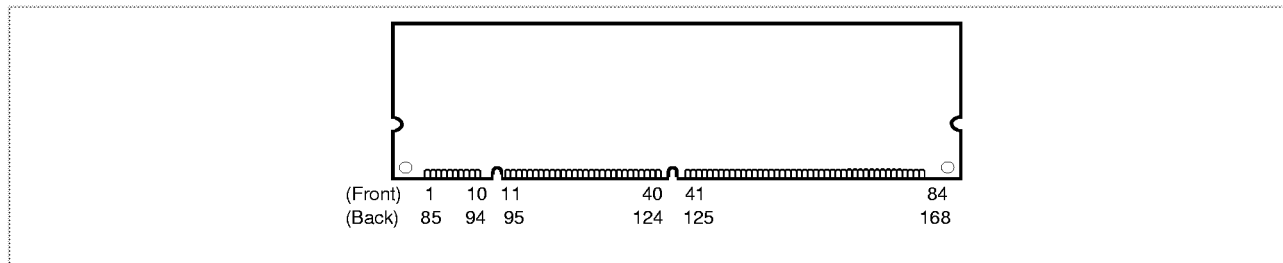

Pin Description

CK0-CK3	Clock Inputs	DQ0 - DQ63	Data Input/Output
CKE0	Clock Enable	CB0 - CB7	Check Bit Data Input/Output
$\overline{\text{RAS}}$	Row Address Strobe	DQMB0 - DQMB7	Data Mask
$\overline{\text{CAS}}$	Column Address Strobe	V _{DD}	Power (3.3V)
$\overline{\text{WE}}$	Write Enable	V _{SS}	Ground
$\overline{\text{S0}}, \overline{\text{S2}}$	Chip Selects	NC	No Connect
A0-A9, A11	Address Inputs	SCL	Serial Presence Detect Clock Input
A10/AP	Address Input/Autoprecharge	SDA	Serial Presence Detect Data Input/Output
BA0, BA1, (A13,A12)	SDRAM Bank Address Inputs	SA0-2	Serial Presence Detect Address Inputs
WP	SPD Write Protect	REGE	Register Enable



IBM13M16734BCC
16M x 72 1 Bank Registered/Buffered SDRAM Module

Pinout

Pin#	Front Side	Pin#	Back Side	Pin#	Front Side	Pin#	Back Side	Pin#	Front Side	Pin#	Back Side	Pin#	Front Side	Pin#	Back Side
1	V _{SS}	85	V _{SS}	22	CB1	106	CB5	43	V _{SS}	127	V _{SS}	64	V _{SS}	148	V _{SS}
2	DQ0	86	DQ32	23	V _{SS}	107	V _{SS}	44	NC	128	CKE0	65	DQ21	149	DQ53
3	DQ1	87	DQ33	24	NC	108	NC	45	$\overline{S2}$	129	NC	66	DQ22	150	DQ54
4	DQ2	88	DQ34	25	NC	109	NC	46	DQMB2	130	DQMB6	67	DQ23	151	DQ55
5	DQ3	89	DQ35	26	V _{DD}	110	V _{DD}	47	DQMB3	131	DQMB7	68	V _{SS}	152	V _{SS}
6	V _{DD}	90	V _{DD}	27	\overline{WE}	111	\overline{CAS}	48	NC	132	NC	69	DQ24	153	DQ56
7	DQ4	91	DQ36	28	DQMB0	112	DQMB4	49	V _{DD}	133	V _{DD}	70	DQ25	154	DQ57
8	DQ5	92	DQ37	29	DQMB1	113	DQMB5	50	NC	134	NC	71	DQ26	155	DQ58
9	DQ6	93	DQ38	30	$\overline{S0}$	114	NC	51	NC	135	NC	72	DQ27	156	DQ59
10	DQ7	94	DQ39	31	NC	115	\overline{RAS}	52	CB2	136	CB6	73	V _{DD}	157	V _{DD}
11	DQ8	95	DQ40	32	V _{SS}	116	V _{SS}	53	CB3	137	CB7	74	DQ28	158	DQ60
12	V _{SS}	96	V _{SS}	33	A0	117	A1	54	V _{SS}	138	V _{SS}	75	DQ29	159	DQ61
13	DQ9	97	DQ41	34	A2	118	A3	55	DQ16	139	DQ48	76	DQ30	160	DQ62
14	DQ10	98	DQ42	35	A4	119	A5	56	DQ17	140	DQ49	77	DQ31	161	DQ63
15	DQ11	99	DQ43	36	A6	120	A7	57	DQ18	141	DQ50	78	V _{SS}	162	V _{SS}
16	DQ12	100	DQ44	37	A8	121	A9	58	DQ19	142	DQ51	79	CK2	163	CK3
17	DQ13	101	DQ45	38	A10/AP	122	BA0	59	V _{DD}	143	V _{DD}	80	NC	164	NC
18	V _{DD}	102	V _{DD}	39	BA1	123	A11	60	DQ20	144	DQ52	81	WP	165	SA0
19	DQ14	103	DQ46	40	V _{DD}	124	V _{DD}	61	NC	145	NC	82	SDA	166	SA1
20	DQ15	104	DQ47	41	V _{DD}	125	CK1	62	NC	146	NC	83	SCL	167	SA2
21	CB0	105	CB4	42	CK0	126	NC	63	NC	147	REGE	84	V _{DD}	168	V _{DD}

Note: All pin assignments are consistent with all 8-byte unbuffered versions.

Ordering Information

Part Number	Organization	Clock Cycle	\overline{CAS} Latency	Access Time	Leads	Dimension	Power
IBM13M16734BCC-260T	16Mx72	10ns	2	6.0ns	Gold	5.25" x 0.157" x 1.70"	3.3V
IBM13M16734BCC-360T			3	6.0ns			
IBM13M16734BCC-10T		15ns	3	8.0ns			



IBM13M16734BCC
16M x 72 1 Bank Registered/Buffered SDRAM Module

x72 ECC SDRAM DIMM Block Diagram (1 Bank, x4 SDRAMs)

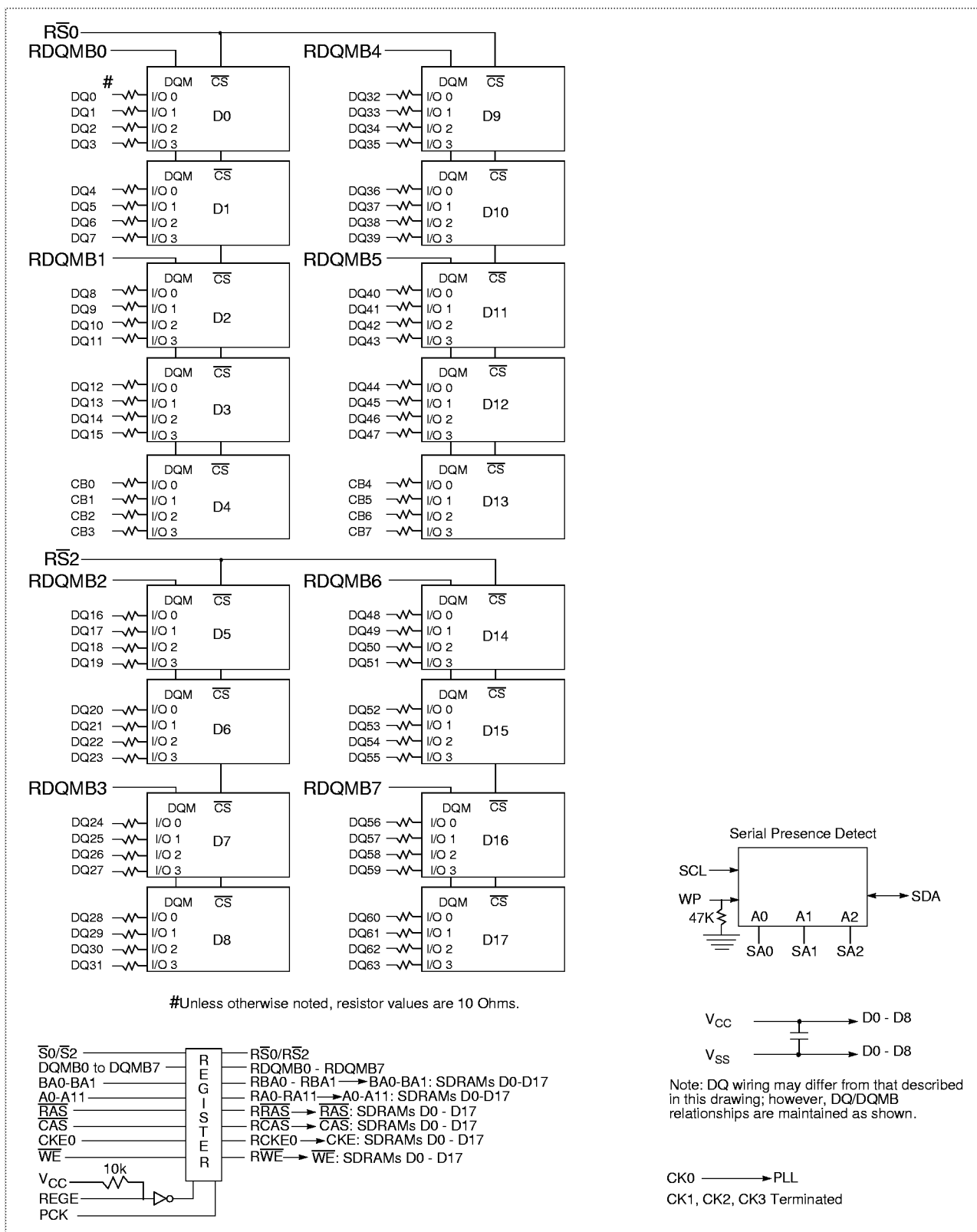



Clock Wiring

Clock Net Wiring (CK0):

One of six SDRAM outputs is shown. All PLL clock SDRAM loads are equal--achieved in part through equal-length wiring.

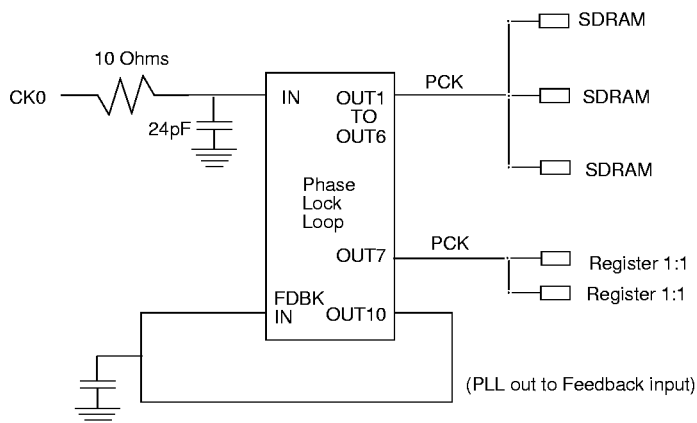

Terminated Clock Nets (CK1, CK2, CK3):

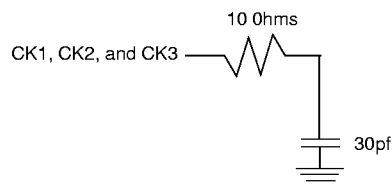

- Notes:
1. The PLL is programmed via a combination of the feedback path and on-DIMM loading. PLL feedback produces zero phase shift from the delayed CK0 input.
 2. Card wiring and capacitance loading variation: ± 100 ps.
 3. Timing is based on a driver with a 1 Volt/ns rise time.
 4. Feedback Capacitor Value determined by PLL phase characteristics.



IBM13M16734BCC

16M x 72 1 Bank Registered/Buffered SDRAM Module

Input/Output Functional Description

Symbol	Type	Signal	Polarity	Function
CK0 - CK3	Input	Pulse	Positive Edge	The system clock inputs. All the SDRAM inputs are sampled on the rising edge of their associated clock. CK0 drives the PLL. CK1, CK2, and CK3 are terminated.
CKE0	Input	Level	Active High	Activates the SDRAM CK signal when high and deactivates the CK signal when low. By deactivating the clocks, CKE low initiates the Power Down mode, the Suspend mode, or the Self Refresh mode.
$\overline{S0}, \overline{S2}$	Input	Pulse	Active Low	Enables the associated SDRAM command decoder when low and disables the command decoder when high. When the command decoder is disabled, new commands are ignored but previous operations continue.
$\overline{RAS}, \overline{CAS}, \overline{WE}$	Input	Pulse	Active Low	When sampled at the positive rising edge of the clock, \overline{CAS} , \overline{RAS} , and \overline{WE} define the operation to be executed by the SDRAM.
BA0, 1	Input	Level	—	Selects which SDRAM bank of four is activated.
A0 - A9, A11 A10/AP	Input	Level	—	During a Bank Activate command cycle, A0-A11 defines the row address (RA0-RA11) when sampled at the rising clock edge. During a Read or Write command cycle, A0-A9 defines the column address (CA0-CA9) when sampled at the rising clock edge. In addition to the column address, AP is used to invoke autoprecharge operation at the end of the burst read or write cycle. If AP is high, autoprecharge is selected and BA0, BA1 defines the bank to be precharged. If AP is low, autoprecharge is disabled. During a Precharge command cycle, AP is used in conjunction with BA0, BA1 to control which bank(s) to precharge. If AP is high, all banks will be precharged regardless of the state of BA0 or BA1. If AP is low, BA0 and BA1 are used to define which bank to precharge.
DQ0 - DQ63, CB0 - CB7	Input Output	Level	—	Data and Check Bit Input/Output pins
DQMB0 - DQMB7	Input	Pulse	Active High	The Data Input/Output masks, associated with one data byte, place the DQ buffers in a high-impedance state when sampled high. In Read mode, DQMB has a latency of two clock cycles in Buffered mode or three clock cycles in Registered mode, and controls the output buffers like an output enable. In Write mode, DQMB has a zero clock latency in Buffered mode and a latency of one clock cycle in Registered mode. In this case, DQMB operates as a byte mask by allowing input data to be written if it is low but blocking the write operation if it is high.
V_{DD}, V_{SS}	Supply			Power and ground for the module.
REGE	Input	Level	Active High (Register Mode Enable)	The Register Enable pin is used to permit the DIMM to operate in "buffered" mode (inputs re-driven asynchronously) or "registered" mode (signals re-driven to SDRAMs when clock rises, and held valid until next rising clock).
SA0 - 2	Input	Level	—	These signals are tied at the system planar to either V_{SS} or V_{DD} to configure the serial SPD EEPROM.
SDA	Input Output	Level	—	This bidirectional pin is used to transfer data into or out of the SPD EEPROM. A resistor must be connected from the SDA bus line to V_{DD} to act as a pullup.
SCL	Input	Pulse	—	This signal is used to clock data into and out of the SPD EEPROM. A resistor may be connected from the SCL bus time to V_{DD} to act as a pullup.
WP	Input	Level	Active High	This signal is pulled low on the DIMM to enable data to be written into the last 128 bytes of the SPD EEPROM.



Serial Presence Detect (Part 1 of 2)

Byte #	Description	SPD Entry Value	Serial PD Data Entry (Hexadecimal)	Notes
0	Number of Serial PD Bytes Written during Production	128	80	
1	Total Number of Bytes in Serial PD device	256	08	
2	Fundamental Memory Type	SDRAM	04	
3	Number of Row Addresses on Assembly	12	0C	
4	Number of Column Addresses on Assembly	10	0A	
5	Number of DIMM Banks	1	01	
6 - 7	Data Width of Assembly	x72	4800	
8	Assembly Voltage Interface Levels	LVTTL	01	
9	SDRAM Device Cycle Time (CL = 3)	10.0ns	A0	1, 2
10	SDRAM Device Access Time from Clock at CL=3	-260	60	
		-360	60	
		-10	80	
11	Assembly Error Detection/Correction Scheme	ECC	02	
12	Assembly Refresh Rate/Type	SR/1X(15.625us)	80	
13	SDRAM Device Width	x4	04	
14	Error Checking SDRAM Device Width	x4	04	
15	SDRAM Device Attr: Min Clk Delay, Random Col Access	1 Clock	01	
16	SDRAM Device Attributes: Burst Lengths Supported	1,2,4,8, Full Page	8F	
17	SDRAM Device Attributes: Number of Device Banks	4	04	
18	SDRAM Device Attributes: CAS Latency	2, 3	06	
19	SDRAM Device Attributes: CS Latency	0	01	
20	SDRAM Device Attributes: WE Latency	0	01	
21	SDRAM Module Attributes	Registered/Buffered with PLL	IF	
22	SDRAM Device Attributes: General	Write-1/Read Burst, Pre-charge All, Auto-Precharge	0E	
23	Minimum Clock Cycle at CLX-1 (CL = 2)	-260	A0	1, 2
		-360, -10	F0	
24	Maximum Data Access Time (t _{AC}) from Clock at CLX-1 (CL = 2)	-260	60	
		-360, -10	90	
25	Minimum Clock Cycle Time at CLX-2 (CL = 1)	N/A	00	
26	Maximum Data Access Time (t _{AC}) from Clock at CLX-2 (CL = 1)	N/A	00	
27	Minimum Row Precharge Time (t _{RP})	-260, -360	14	
		-10	1E	
28	Minimum Row Active to Row Active delay (t _{RRD})	20.0ns	14	
29	Minimum RAS to CAS delay (t _{RCD})	-260, -360	14	
		-10	1E	
30	Minimum RAS Pulse width (t _{RAS})	-260, -360	32	
		-10	3C	
31	Module Bank Density	128MB	20	

1. In a registered DIMM, data is delayed an additional clock cycle due to the on-DIMM pipeline register (that is, Device CL [clock cycles] + 1 = DIMM CAS latency).
2. Minimum application clock cycle time is 10ns (100MHz) for the -260 and -360 and 15ns (66MHz) for the -10.
3. cc = Checksum Data byte, 00-FF (Hex).
4. "R" = Alphanumeric revision code, A-Z, 0-9.
5. rr = ASCII coded revision code byte "R".
6. ww = Binary coded decimal week code, 01-52 (Decimal) ' 01-34 (Hex).
7. yy = Binary coded decimal year code, 00-99 (Decimal) ' 00-63 (Hex).
8. ss = Serial number data byte, 00-FF (Hex).



IBM13M16734BCC

16M x 72 1 Bank Registered/Buffered SDRAM Module

Serial Presence Detect (Part 2 of 2)

Byte #	Description		SPD Entry Value	Serial PD Data Entry (Hexadecimal)	Notes
32	Address and Command Setup Time Before Clock	-260, -360	2.0ns	20	
		-10	3.0ns	30	
33	Address and Command Hold Time After Clock	-260, -360	1.0ns	10	
		-10	1.0ns	10	
34	Data Input Setup Time Before Clock	-260, -360	2.0ns	20	
		-10	3.0ns	30	
35	Data Input Hold Time After Clock	-260, -360	1.0ns	10	
		-10	1.0ns	10	
36 - 61	Reserved		Undefined	00	
62	SPD Revision	-260, -360	PC100 1.2A	12	
		-10	02	02	
63	Checksum for bytes 0 - 62		Checksum Data	cc	3
64 - 71	Manufacturers' JEDEC ID Code		IBM	A400000000000000	
72	Assembly Manufacturing Location		Toronto, Canada	91	
			Vimercate, Italy	53	
73 - 90	Assembly Part Number	-260	ASCII '13M16734BC"R"-260T'	31334D3136373334 4243rr2D323630542 020	4, 5
		-360	ASCII '13M16734BC"R"-360T'	31334D3136373334 4243rr2D333630542 020	
		-10	ASCII '13M16734BC"R"-10T'	31334D3136373334 4243rr2D313054202 020	
91 - 92	Assembly Revision Code		"R" plus ASCII blank	rr20	5
93 - 94	Assembly Manufacturing Date		Year/Week Code	yyww	6, 7
95 - 98	Assembly Serial Number		Serial Number	ssssssss	8
99 - 125	Reserved		Undefined	Not Specified	
126	Module Supports this Clock Frequency	-260, -360	100MHz	64	
		-10	66MHz	66	
127	Attributes for clock frequency defined in Byte 126	-260, -360	CLK0, CL=3, ConAP	85	
		-10	CL = 2, 3	06	
128 - 255	Open for Customer Use		Undefined	00	

1. In a registered DIMM, data is delayed an additional clock cycle due to the on-DIMM pipeline register (that is, Device CL [clock cycles] + 1 = DIMM CAS latency).
2. Minimum application clock cycle time is 10ns (100MHz) for the -260 and -360 and 15ns (66MHz) for the -10.
3. cc = Checksum Data byte, 00-FF (Hex).
4. "R" = Alphanumeric revision code, A-Z, 0-9.
5. rr = ASCII coded revision code byte "R".
6. ww = Binary coded decimal week code, 01-52 (Decimal) ' 01-34 (Hex).
7. yy = Binary coded decimal year code, 00-99 (Decimal) ' 00-63 (Hex).
8. ss = Serial number data byte, 00-FF (Hex).



Absolute Maximum Ratings

Symbol	Parameter	Rating	Units	Notes	
V_{DD}	Power Supply Voltage	-0.3 to +4.6			
V_{IN}	Input Voltage	SDRAM Devices	-1.0 to +4.6	V	1
		Serial PD Device	-0.3 to +6.5		
		Register	0 - V_{DD}		
		PLL	0 - V_{DD}		
V_{OUT}	Output Voltage	SDRAM Devices	-1.0 to +4.6		
		Serial PD Device	-0.3 to +6.5		
T_A	Operating Temperature (ambient)	0 to +70	°C	1	
T_{STG}	Storage Temperature	-55 to +125	°C	1	
P_D	Power Dissipation	10.3	W	1, 2	
I_{OUT}	Short Circuit Output Current	50	mA	1	
F_{MIN}	Minimum Operating Frequency	66	MHz		

- Stresses greater than those listed under "Absolute Maximum Ratings" may cause permanent damage to the device. This is a stress rating only and functional operation of the device at these or any other conditions above those indicated in the operational sections of this specification is not implied. Exposure to absolute maximum rating conditions for extended periods may affect reliability.
- Maximum power is calculated assuming the physical bank is in Auto Refresh Mode.

Recommended DC Operating Conditions ($T_A = 0$ to 70°C)

Symbol	Parameter	Rating			Units	Notes
		Min.	Typ.	Max.		
V_{DD}	Supply Voltage	3.0	3.3	3.6	V	1
V_{IH}	Input High Voltage	2.0	—	$V_{DD} + 0.3$	V	1
V_{IL}	Input Low Voltage	-0.3	—	0.8	V	1

- All voltages referenced to V_{SS} .



IBM13M16734BCC

16M x 72 1 Bank Registered/Buffered SDRAM Module

Capacitance ($T_A = 25\text{ C}$, $f = 1\text{ MHz}$, $V_{DD} = 3.3\text{ V} \pm 0.3\text{ V}$)

Symbol	Parameter	Organization	Units
		x72 Max.	
C _{I1}	Input Capacitance (A0 - A9, A10/AP, BA0, BA1, A11)	10.5	pF
C _{I2}	Input Capacitance ($\overline{\text{RAS}}$)	9.0	pF
C _{I3}	Input Capacitance ($\overline{\text{CAS}}$)	9.5	pF
C _{I4}	Input Capacitance (S0, S2)	12	pF
C _{I5}	Input Capacitance (CKE0)	19	pF
C _{I6}	Input Capacitance (CK0)	40	pF
C _{I7}	Input Capacitance (DQMB0 - DQMB7)	11	pF
C _{I8}	Input Capacitance (SA0 - SA2, SCL, WP)	9	pF
C _{I9}	Input Capacitance (REGE)	10	pF
C _{I10}	Input Capacitance (CK1 - CK3)	34	pF
C _{I11}	Input Capacitance (WE)	11	pF
C _{IO1}	Input/Output Capacitance (DQ0 - DQ63, CB0 - CB7)	14	pF
C _{IO2}	Input/Output Capacitance (SDA)	11	pF



DC Output Load Circuit

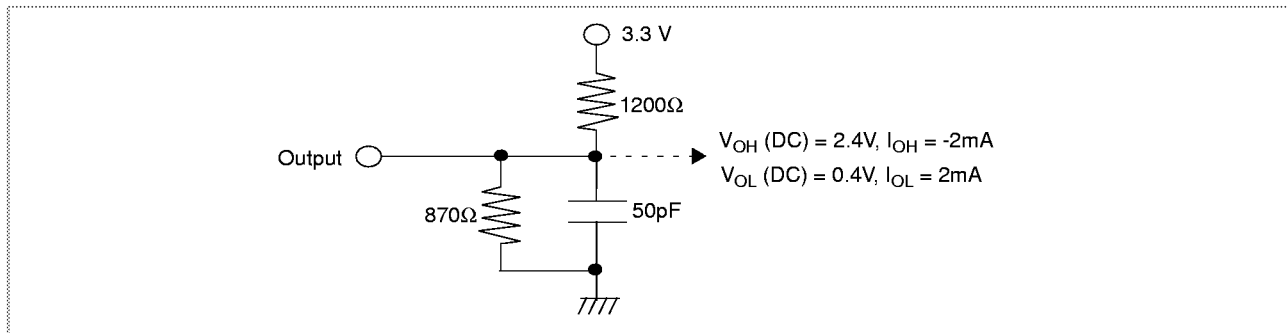

Input/Output Characteristics ($T_A = 0$ to $+70^\circ C$, $V_{DD} = 3.3V \pm 0.3V$)

Symbol	Parameter	x72		Units	Notes	
		Min.	Max.			
$I_{I(L)}$	Input Leakage Current, any input ($0.0V \leq V_{IN} \leq 3.6V$), All Other Pins Not Under Test = 0V	Address and Control Inputs		10	10	μA
		DQ0-63, CB0 - 7		-2	+2	
$I_{O(L)}$	Output Leakage Current (D_{OUT} is disabled, $0.0V \leq V_{OUT} \leq 3.6V$)	DQ0-63, CB0 - 7		-2	+2	μA
		SDA		-1	+1	
V_{OH}	Output Level Output "H" Level Voltage ($I_{OUT} = -2.0mA$)	2.4	V_{DD}	V	1	
V_{OL}	Output Level Output "L" Level Voltage ($I_{OUT} = +2.0mA$)	0.0	0.4			

1. See DC output load circuit.



IBM13M16734BCC

16M x 72 1 Bank Registered/Buffered SDRAM Module

Operating, Standby, and Refresh Currents ($T_A = 0$ to $+70^\circ\text{C}$, $V_{DD} = 3.3\text{V} \pm 0.3\text{V}$)

Parameter	Symbol	Test Condition	Speed			Units	Notes
			-260	-360	-10		
Operating Current 1 bank operation	I_{CC1}	$t_{RC} = t_{RC}(\text{min})$, $t_{CK} = \text{min}$ Active-Precharge command cycling without burst operation	1597	1597	1180	mA	1
Precharge Standby Current in Power Down Mode	I_{CC2P}	$\text{CKE0} \leq V_{IL}(\text{max})$, $t_{CK} = \text{min}$, $\overline{\text{CS}} = V_{IH}(\text{min})$	265	265	208	mA	1
	I_{CC2PS}	$\text{CKE0} \leq V_{IL}(\text{max})$, $t_{CK} = \text{Infinity}$, $\overline{\text{S0}}, \overline{\text{S2}} = V_{IH}(\text{min})$	43	43	43	mA	
Precharge Standby Current in Non- Power Down Mode	I_{CC2}	$\text{CKE0} \geq V_{IH}(\text{min})$, $t_{CK} = \text{min}$, $\overline{\text{S0}}, \overline{\text{S2}} = V_{IH}(\text{min})$	877	877	640	mA	1
	I_{CC2S}	$\text{CKE0} \geq V_{IH}(\text{min})$, $t_{CK} = \text{Infinity}$, $\overline{\text{S0}}, \overline{\text{S2}} = V_{IH}(\text{min})$	115	115	115	mA	
No Operating Current (Active state: 4bank)	I_{CC3}	$\text{CKE0} \geq V_{IH}(\text{min})$, $t_{CK} = \text{min}$, $\overline{\text{S0}}, \overline{\text{S2}} = V_{IH}(\text{min})$	967	967	730	mA	1
	I_{CC3P}	$\text{CKE0} \leq V_{IL}(\text{max})$, $t_{CK} = \text{min}$, $\overline{\text{S0}}, \overline{\text{S2}} = V_{IH}(\text{min})$ (Power Down Mode)	373	373	316	mA	1
Burst Operating Current (Active state: 4bank)	I_{CC4}	$t_{CK} = \text{min}$, Read command cycling	2407	2407	1810	mA	1, 2
Auto (CBR) Refresh Current	I_{CC5}	$t_{CK} = \text{min}$, CBR command cycling	2857	2857	2170	mA	1
Self Refresh Current	I_{CC6}	$\text{CKE0} \leq 0.2\text{V}$	43	43	43	mA	

1. These parameters depend on the cycle rate and are measured with the cycle determined by the minimum value of t_{CK} and t_{RC} . Input signals are changed once during $t_{CK}(\text{min})$. $t_{CK}(\text{min}) = 10\text{ns}$ (for -260 and -360) and 15ns (for -10).

2. The specified values are obtained with the DIMM data outputs open.



AC Characteristics ($T_A = 0$ to $+70^\circ\text{C}$, $V_{DD} = 3.3\text{V} \pm 0.3\text{V}$)

1. An initial pause of $200\mu\text{s}$, with CKE0 held high, is required after power-up. A Precharge All Banks command must be given followed by a minimum of eight Auto (CBR) Refresh cycles before or after the Mode Register Set operation.
2. AC timing tests have $V_{IL} = 0.8\text{V}$ and $V_{IH} = 2.0\text{V}$ with the timing referenced to the 1.4V crossover point.
3. The Transition time is measured between V_{IH} and V_{IL} (or between V_{IL} and V_{IH}).
4. AC measurements assume $t_T = 1.2\text{ns}$ (1 Volt/ns rise time).
5. In addition to meeting the transition rate specification, the clock and CKE must transit between V_{IH} and V_{IL} (or between V_{IL} and V_{IH}) in a monotonic manner.
6. A 1 ms stabilization time is required for the integrated PLL circuit to obtain phase lock of its feedback signal to its reference signal.

AC Characteristics Diagrams

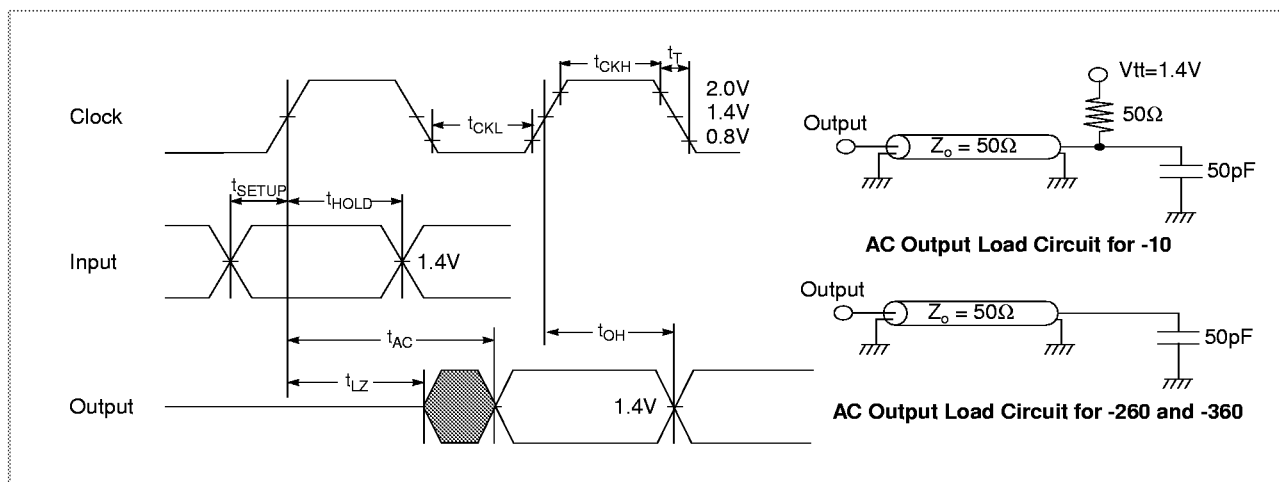



IBM13M16734BCC

16M x 72 1 Bank Registered/Buffered SDRAM Module

Clock and Clock Enable Parameters

Symbol	Parameter		-260, (Device CL, t_{RCD} , $t_{RP} = 2, 2, 2$)		-360, (Device CL, t_{RCD} , $t_{RP} = 3, 2,$ 2)		-10		Units	Note
			Min.	Max.	Min.	Max.	Min.	Max.		
t_{CK4}	Clock Cycle Time, DIMM \overline{CAS} Latency = 4	Registered	10	1000	10	1000	15	1000	ns	1
t_{CK3}	Clock Cycle Time, DIMM \overline{CAS} Latency = 3	Registered	10	1000	15	1000	15	1000	ns	1, 2
		Buffered	10	1000	10	1000	15	1000	ns	
t_{CK2}	Clock Cycle Time, DIMM \overline{CAS} Latency = 2	Buffered	10	1000	15	1000	15	1000	ns	1
t_{AC4}	Clock Access Time, DIMM \overline{CAS} Latency = 4	Registered	—	7.7	—	7.7	—	9.7	ns	1, 3
t_{AC3}	Clock Access Time, DIMM \overline{CAS} Latency = 3	Registered	—	7.7	—	10.7	—	10.7	ns	1, 3
		Buffered	—	7.7	—	7.7	—	9.7	ns	
t_{AC2}	Clock Access Time, DIMM \overline{CAS} Latency = 2	Buffered	—	7.7	—	10.7	—	10.7	ns	1, 3
t_{CKH}	Clock High Pulse Width		3	—	3	—	3	—	ns	4
t_{CKL}	Clock Low Pulse Width		3	—	3	—	3	—	ns	4
t_{CES}	Clock Enable Set-up Time	Registered	2.0	—	2.0	—	2.0	—	ns	1
		Buffered	7.2	—	7.2	—	8.2	—	ns	
t_{CEH}	Clock Enable Hold Time	Registered	1.6	—	1.6	—	1.6	—	ns	1
		Buffered	0.2	—	0.2	—	0.2	—	ns	
t_{SB}	Power Down mode Entry Time		0	10	0	10	0	10	ns	
t_T	Transition Time (Rise and Fall)		0.5	10	0.5	10	0.5	10	ns	

1. DIMM \overline{CAS} latency = device CL [clock cycles] + 1 for Register mode; DIMM \overline{CAS} latency is one clock less for Buffer mode.
2. For 66Mhz clock, DIMM \overline{CAS} Latency = 3 is the standard application.
3. Access time is measured at 1.4V. See AC output load circuit.
4. t_{CKH} is the pulse width of CLK measured from the positive edge to the negative edge referenced to V_{IH} (min). t_{CKL} is the pulse width of CLK measured from the negative edge to the positive edge referenced to V_{IL} (max).



Common Parameters

Symbol	Parameter	-260		-360		-10		Units	Note	
		Min.	Max.	Min.	Max.	Min.	Max.			
t_{CS}	Command Setup Time	Registered	2.0		2.0		2.0	ns	1, 2	
		Buffered	7.2		7.2		8.2	ns		
t_{CH}	Command Hold Time	Registered	1.6		1.6		1.6	ns	1, 2	
		Buffered	0.2		0.2		0.2	ns		
t_{AS}	Address and Bank Select Set-up Time	Registered	2.0		2.0		2.0	ns	1, 2	
		Buffered	7.2		7.2		8.2	ns		
t_{AH}	Address and Bank Select Hold Time	Registered	1.6		1.6		1.6	ns	1, 2	
		Buffered	0.2		0.2		0.2	ns		
t_{RCD}	\overline{RAS} to \overline{CAS} Delay		20		20		30	ns	1	
t_{RC}	Bank Cycle Time		70		70		90	ns	1	
t_{RAS}	Active Command Period		50	100000	50	100000	60	100000	ns	1
t_{RP}	Precharge Time		20		20		30	ns	1	
t_{RRD}	Bank to Bank Delay Time		20		20		30	ns	1	
t_{CCD}	\overline{CAS} to \overline{CAS} Delay Time (Same Bank)		1		1		1	CLK		

1. These parameters account for the number of clock cycles and depend on the operating frequency of the clock as follows: the number of clock cycles = specified value of timing/clock period (count fractions as a whole number).
2. The setup and hold times refer to the addition of the register. Note that although the Buffered setup times appear much greater, there is no additional clock cycle as there is in Registered mode.

Mode Register Set Cycle

Symbol	Parameter	-260		-360		-10		Units	Notes
		Min.	Max.	Min.	Max.	Min.	Max.		
t_{RSC}	Mode Register Set Cycle Time	20	—	20	—	30	—	ns	

Refresh Cycle

Symbol	Parameter	-260		-360		-10		Units	Notes
		Min.	Max.	Min.	Max.	Min.	Max.		
t_{SREX}	Self Refresh Exit Time	10	—	10	—	10		CLK	1
t_{REF}	Refresh Period	—	64	—	64		64	ms	

1. 4096 cycles.



IBM13M16734BCC

16M x 72 1 Bank Registered/Buffered SDRAM Module

Read Cycle

Symbol	Parameter	-260		-360		-10		Units	Notes
		Min.	Max.	Min.	Max.	Min.	Max.		
t_{OH}	Data Out Hold Time	3.6		3.6		3.6		ns	
t_{LZ}	Data Out to Low Impedance Time	1.9		1.9		1.9		ns	
t_{HZ}	Data Out to High Impedance Time	4.9	9.9	4.9	9.9	4.9	11.9	ns	1
t_{DQZ}	DQM Data Out Disable Latency	Registered	3		3		3		CLK
		Buffered	2		2		2		CLK

1. Referenced to the time at which the output achieves the open circuit condition, not to output voltage levels.

Write Cycle

Symbol	Parameter	-260		-360		-10		Units	
		Min.	Max.	Min.	Max.	Min.	Max.		
t_{DS}	Data In Set-up Time	2.0		2.0		3.0		ns	
t_{DH}	Data In Hold Time	2.0		2.0		2.0		ns	
t_{DPL2}	Data Input to Precharge	20		20		0		ns	
t_{DPL3}	Data Input to Precharge	10		10		0		ns	
t_{DQW}	DQM Write Mask Latency	Registered	1		1		1		CLK
		Buffered	0		0		0		CLK

Presence Detect Read and Write Cycle

Symbol	Parameter	Min.	Max.	Units	Notes
f_{SCL}	SCL Clock Frequency		100	kHZ	
T_I	Noise Suppression Time Constant at SCL, SDA Inputs		100	ns	
t_{AA}	SCL Low to SDA Data Out Valid	0.3	3.5	μ s	
t_{BUF}	Time the Bus Must Be Free before a New Transmission Can Start	4.7		μ s	
$t_{HD:STA}$	Start Condition Hold Time	4.0		μ s	
t_{LOW}	Clock Low Period	4.7		μ s	
t_{HIGH}	Clock High Period	4.0		μ s	
$t_{SU:STA}$	Start Condition Setup Time (for a Repeated Start Condition)	4.7		μ s	
$t_{HD:DAT}$	Data In Hold Time	0		μ s	
$t_{SU:DAT}$	Data In Setup Time	250		ns	
t_r	SDA and SCL Rise Time		1	μ s	
t_f	SDA and SCL Fall Time		300	ns	
$t_{SU:STO}$	Stop Condition Setup Time	4.7		μ s	

1. The write cycle time (t_{WR}) is the time from a valid stop condition of a write sequence to the end of the internal erase/program cycle. During the write cycle, the bus interface circuits are disabled, SDA is allowed to remain high per the bus-level pullup resistor, and the device does not respond to its slave address.



IBM13M16734BCC
16M x 72 1 Bank Registered/Buffered SDRAM Module

Presence Detect Read and Write Cycle

Symbol	Parameter	Min.	Max.	Units	Notes
t_{DH}	Data Out Hold Time	300		ns	
t_{WR}	Write Cycle Time		15	ms	1

1. The write cycle time (t_{WR}) is the time from a valid stop condition of a write sequence to the end of the internal erase/program cycle. During the write cycle, the bus interface circuits are disabled, SDA is allowed to remain high per the bus-level pullup resistor, and the device does not respond to its slave address.

Functional Description and Timing Diagrams

Refer to IBM 168 Pin SDRAM Registered DIMM Functional Description and Timing Diagrams (Document 01L5868.E24564) for registered-mode operation.

Refer to the IBM 64Mb Synchronous DRAM datasheet (Document 19L3264.E35855A) for the functional description and timing diagrams for buffered-mode operation.

Refer to the IBM Application Notes *Serial Presence Detect on Memory DIMMs* and *SDRAM Presence Detect Definitions* for the Serial Presence Detect functional description and timings.



IBM13M16734BCC
 16M x 72 1 Bank Registered/Buffered SDRAM Module

Layout Drawing

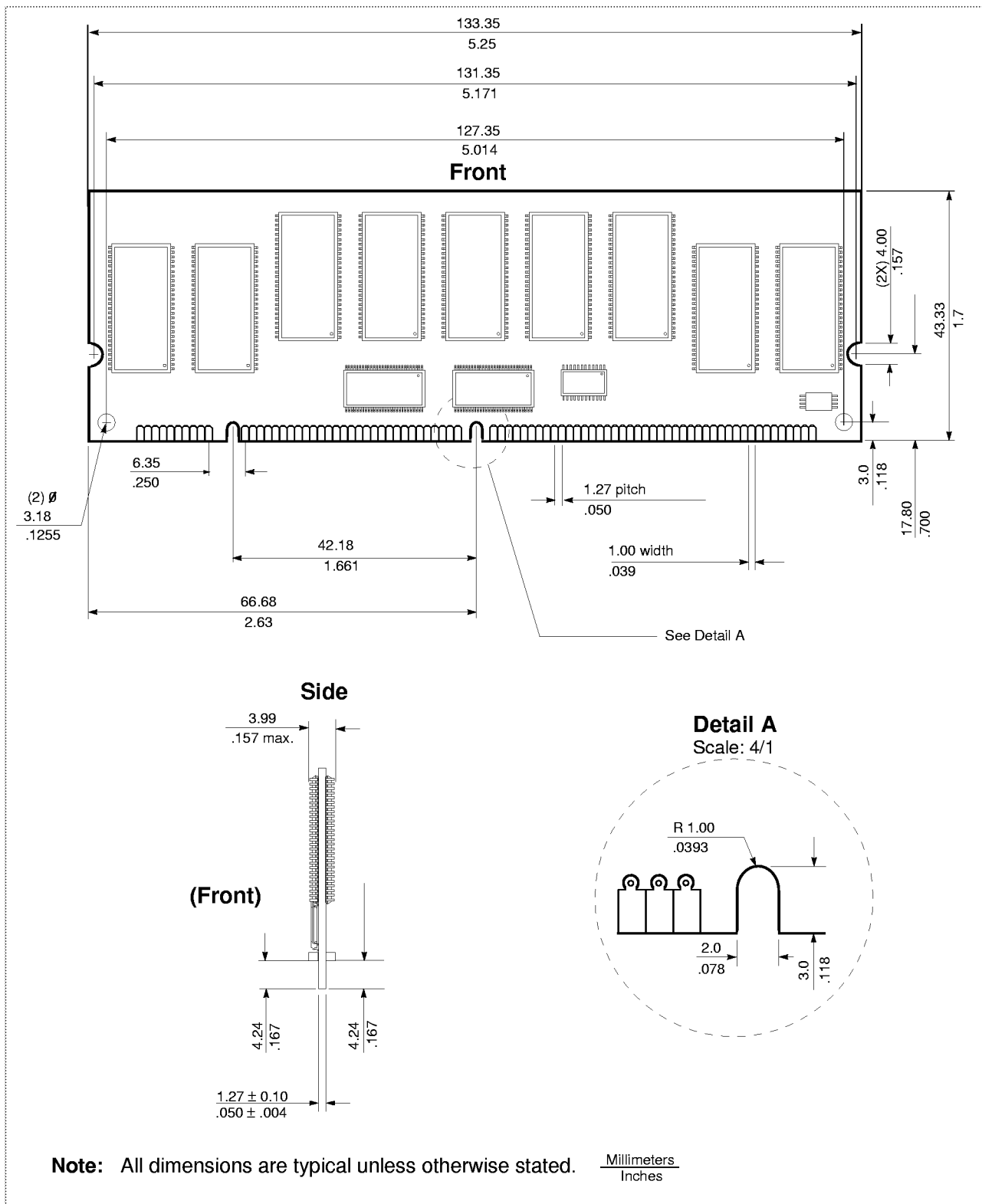



IBM13M16734BCC
16M x 72 1 Bank Registered/Buffered SDRAM Module

Revision Log

Rev	Contents of Modification
4/98	Initial release.
6/98	Updated Input Leakage Current. Added Note 4 to Clock Net Wiring description. Updated DQ, CB capacitance.
2/99	Updated currents to reflect 1/28/99 64Mb Rev B Specs. Updated DQ capacitance to reflect 1/28/99 64Mb Rev B Specs.