

# 0.5 – 6 GHz Low Noise GaAs MMIC Amplifier

## Technical Data

### Features

- Ultra-Miniature Package
- Internally Biased, Single +5 V Supply (14 mA)
- 1.6 dB Noise Figure at 2.4 GHz
- 21.8 dB Gain at 2.4 GHz
- +3.1 dBm P<sub>1dB</sub> at 2.4 GHz

### Applications

- LNA or Gain Stage for ISM, PCS, MMDS, GPS, TVRO, and Other C band Applications

### Surface Mount Package SOT-363 (SC-70)

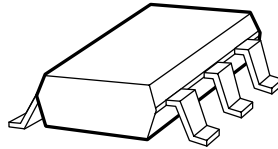

### Pin Connections and Package Marking

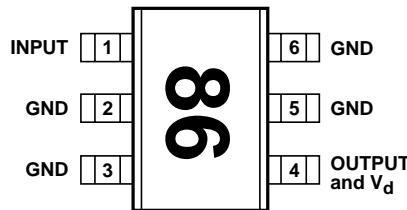

**Note:**  
Package marking provides orientation and identification.

### Equivalent Circuit

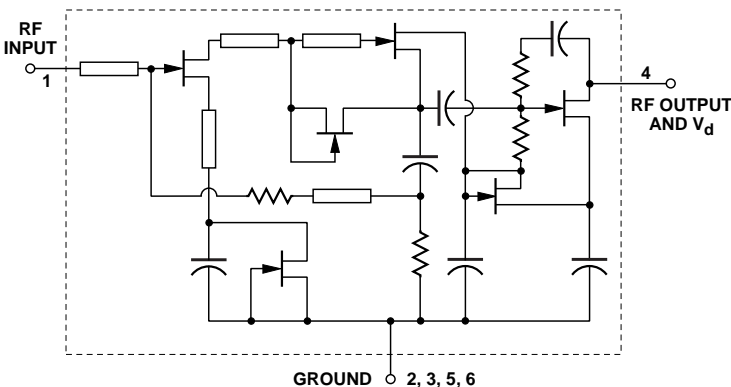

### MGA-86563

### Description

Hewlett-Packard's MGA-86563 is an economical, easy-to-use GaAs MMIC amplifier that offers low noise figure and excellent gain for applications from 0.5 to 6 GHz. Packaged in an ultra-miniature SOT-363 package, it requires half the board space of the SOT-143.

The MGA-86563 may be used without impedance matching as a high performance 2 dB NF gain block. Alternatively, with the addition of a simple shunt-series inductor at the input, the device noise figure can be reduced to 1.6 dB at 2.4 GHz. For 1.5 GHz applications and above, the output is well matched to 50 Ω. Below 1.5 GHz, gain can be increased by using conjugate matching.

The circuit uses state-of-the-art PHEMT technology with self-biasing current sources, a source-follower interstage, resistive feedback, and on-chip impedance matching networks. A patented, on-chip active bias circuit allows operation from a single +5 V power supply. Current consumption is only 14 mA, making this part suitable for battery powered applications.

## MGA-86563 Absolute Maximum Ratings

Symbol	Parameter	Units	Absolute Maximum <sup>[1]</sup>
V <sub>d</sub>	Device Voltage, RF Output to Ground	V	9
V <sub>in</sub>	RF Input Voltage to Ground	V	+0.5 -1.0
P <sub>in</sub>	CW RF Input Power	dBm	+13
T <sub>ch</sub>	Channel Temperature	°C	150
T <sub>STG</sub>	Storage Temperature	°C	-65 to 150

### Thermal Resistance<sup>[2]</sup>:

$$\theta_{ch-c} = 160^{\circ}\text{C/W}$$

#### Notes:

1. Operation of this device above any one of these limits may cause permanent damage.
2. T<sub>C</sub> = 25°C (T<sub>C</sub> is defined to be the temperature at the package pins where contact is made to the circuit board).

## Electrical Specifications, T<sub>C</sub> = 25°C, Z<sub>0</sub> = 50 Ω unless noted, V<sub>d</sub> = 5 V

Symbol	Parameters and Test Conditions	Units	Min.	Typ.	Max.
G <sub>test</sub>	Gain in Test Circuit <sup>[1]</sup>	f = 2.0 GHz	17	20	
NF <sub>test</sub>	Noise Figure in Test Circuit <sup>[1]</sup>	f = 2.0 GHz		1.8	2.3
NF <sub>O</sub>	Optimum Noise Figure (Tuned for lowest noise figure)	f = 0.9 GHz f = 2.0 GHz f = 2.4 GHz f = 4.0 GHz f = 6.0 GHz	dB	2.0 1.5 1.6 1.7 2.0	
G <sub>A</sub>	Associated Gain at NF <sub>O</sub> (Tuned for lowest noise figure)	f = 0.9 GHz f = 2.0 GHz f = 2.4 GHz f = 4.0 GHz f = 6.0 GHz	dB	20.8 22.7 22.5 18.0 13.7	
P <sub>1 dB</sub>	Output Power at 1 dB Gain Compression (50 Ω Performance)	f = 0.9 GHz f = 2.0 GHz f = 2.4 GHz f = 4.0 GHz f = 6.0 GHz	dBm	3.6 4.1 4.2 4.3 3.3	
IP <sub>3</sub>	Third Order Intercept Point	f = 2.4 GHz	dBm	+15	
VSWR <sub>in</sub>	Input VSWR	f = 2.4 GHz		2.3:1	
VSWR <sub>out</sub>	Output VSWR	f = 2.4 GHz		1.7:1	
I <sub>d</sub>	Device Current		mA	14	

#### Note:

1. Guaranteed specifications are 100% tested in the circuit in Figure 10 in the Applications Information section.

**MGA-86563 Typical Performance,  $T_C = 25^\circ\text{C}$ ,  $V_d = 5\text{ V}$**

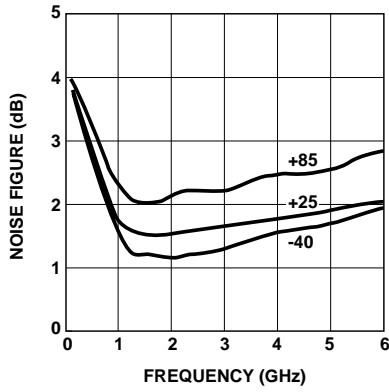

Figure 1. Minimum Noise Figure (Optimum Tuning) vs. Frequency and Temperature.

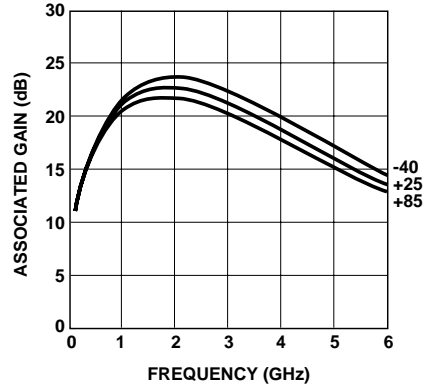

Figure 2. Associated Gain (Optimum Tuning) vs. Frequency and Temperature.

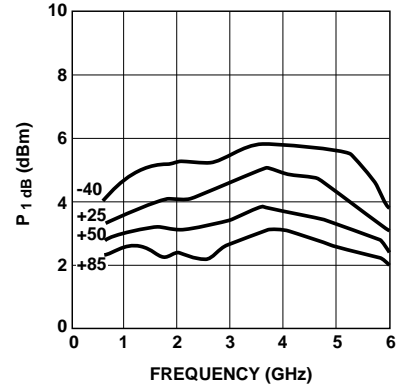

Figure 3. Output Power for 1 dB Gain Compression (into  $50\ \Omega$ ) vs. Frequency and Temperature.

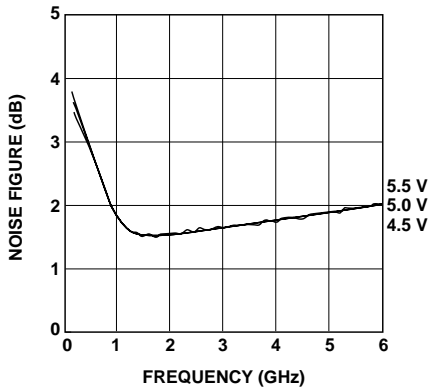

Figure 4. Minimum Noise Figure (Optimum Tuning) vs. Frequency and Voltage.

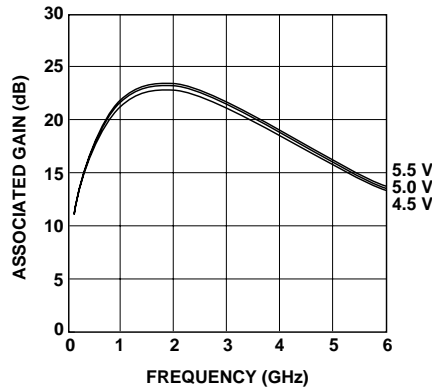

Figure 5. Associated Gain (Optimum Tuning) vs. Frequency and Voltage.

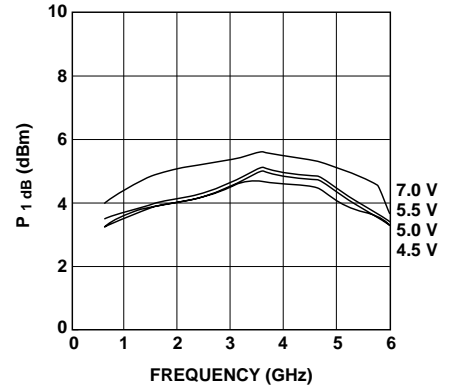

Figure 6. Output Power for 1 dB Gain Compression (into  $50\ \Omega$ ) vs. Frequency and Voltage.

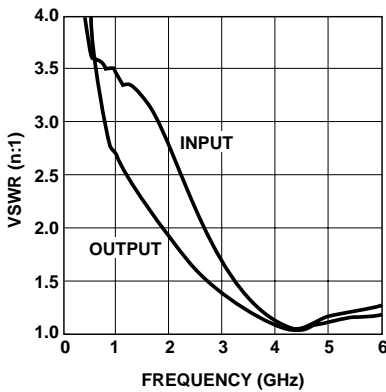

Figure 7. Input and Output VSWR (into  $50\ \Omega$ ) vs. Frequency.

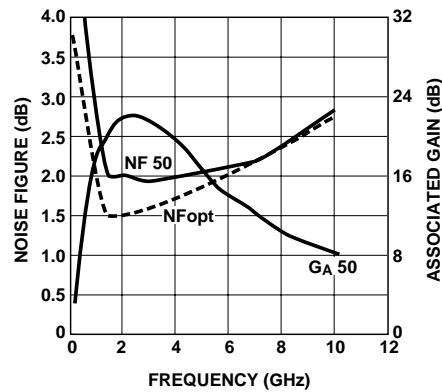

Figure 8.  $50\ \Omega$  Noise Figure and Associated Gain vs. Frequency.

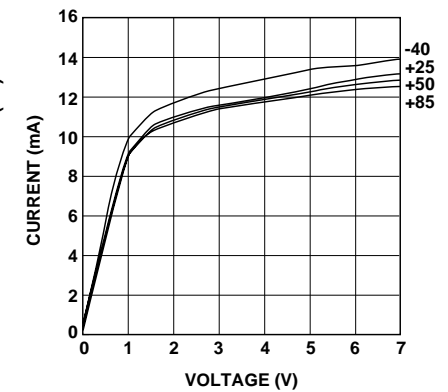

Figure 9. Device Current vs. Voltage.

**MGA-86563 Typical Scattering Parameters<sup>[1]</sup>,  $T_C = 25^\circ\text{C}$ ,  $Z_0 = 50\ \Omega$ ,  $V_d = 5\ \text{V}$**

Freq. GHz	$S_{11}$		$S_{21}$			$S_{12}$			$S_{22}$		K Factor
	Mag.	Ang.	dB	Mag.	Ang.	dB	Mag.	Ang.	Mag.	Ang.	
0.1	0.84	-17	3.1	1.42	76	-39.8	0.010	15	0.85	-15	3.27
0.5	0.57	-29	14.7	5.41	41	-44.3	0.006	-23	0.59	-39	6.77
1.0	0.55	-41	18.9	8.77	4	-51.2	0.003	-2	0.46	-53	10.49
1.5	0.53	-57	20.8	10.97	-29	-52.1	0.002	70	0.38	-66	14.23
2.0	0.47	-73	21.7	12.14	-62	-45.2	0.005	96	0.32	-78	5.94
2.5	0.38	-89	21.8	12.33	-94	-40.7	0.009	102	0.24	-89	3.78
3.0	0.26	-104	21.3	11.61	-125	-37.4	0.014	100	0.16	-99	2.92
3.5	0.14	-115	20.2	10.23	-152	-34.4	0.018	97	0.09	-102	2.75
4.0	0.04	-106	18.8	8.75	-177	-32.6	0.023	92	0.03	-82	2.58
4.5	0.04	-6	17.4	7.44	162	-30.9	0.027	88	0.03	1	2.58
5.0	0.07	2	16.1	6.41	143	-29.6	0.032	83	0.05	20	2.53
5.5	0.09	-4	14.9	5.57	126	-28.1	0.038	78	0.06	19	2.45
6.0	0.11	-17	13.9	4.93	110	-26.0	0.044	72	0.08	14	2.38
6.5	0.12	-28	12.9	4.40	94	-24.9	0.050	65	0.08	4	2.35
7.0	0.13	-36	12.0	3.96	79	-23.8	0.057	59	0.09	-3	2.29
7.5	0.15	-44	11.1	3.58	65	-22.6	0.065	53	0.11	-12	2.21
8.0	0.17	-53	10.4	3.30	51	-22.6	0.074	44	0.13	-21	2.10

**MGA-86563 Typical Noise Parameters<sup>[1]</sup>,**

$T_C = 25^\circ\text{C}$ ,  $Z_0 = 50\ \Omega$ ,  $V_d = 5\ \text{V}$

Frequency (GHz)	NF <sub>o</sub> (dB)	$\Gamma_{opt}$		R <sub>N</sub> /50 $\Omega$
		Mag.	Ang.	
5	2.8	0.61	4	1.16
1.0	1.8	0.56	24	0.47
1.5	1.5	0.50	33	0.34
2.0	1.5	0.45	40	0.38
2.5	1.6	0.41	50	0.33
3.0	1.6	0.38	57	0.30
4.0	1.7	0.32	73	0.28
5.0	1.9	0.24	98	0.27
6.0	2.1	0.15	131	0.24

**Note:**

1. Reference plane per Figure 11 in Applications Information section.

## MGA-86563 Applications Information

### Introduction

The MGA-86563 is a high gain, low noise RF amplifier for use in wireless RF applications within the 0.5 to 6 GHz frequency range. The MGA-86563 is a three-stage, GaAs Microwave Monolithic Integrated Circuit (MMIC) amplifier that uses internal feedback to provide wideband gain and impedance matching.

A patented, active bias circuit makes use of current sources to “re-use” the drain current in all three stages of gain, thus minimizing the required supply current and decreasing sensitivity to variations in power supply voltage.

### Test Circuit

The circuit shown in Figure 10 is used for 100% RF testing of Noise Figure and Gain. The input of this circuit is fixed tuned for a conjugate power match (maximum power transfer, or, minimum Input VSWR) at 2 GHz. Tests in this circuit are used to guarantee the  $NF_{test}$  and  $G_{test}$  parameters shown in the Electrical Specifications Table.

The 3.3 nH inductor, L1 (Coilcraft, Cary, IL or equivalent) in series with the input of the amplifier matches the input to 50  $\Omega$  at 2 GHz.

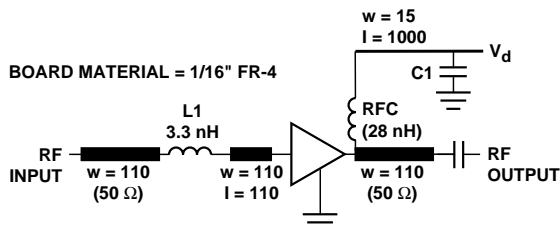

Figure 10. Test Circuit for 2 GHz.

The parameter test circuit uses a high impedance RF choke to apply  $V_d$  to the MMIC while isolating the power supply from the RF Output of the amplifier.

### Phase Reference Planes

The positions of the reference planes used to measure S-Parameters and to specify  $\Gamma_{opt}$  for the Noise Parameters are shown in Figure 11. As seen in the illustration, the reference planes are located at the extremities of the package leads.

### Biasing

The MGA-86563 is a voltage-biased device and operates from a single +5 volt power supply. With a typical current drain of only 14 mA, the MGA-86563 is suitable for use in battery powered applications. RF performance is very stable over a wide variation of power supply voltage.

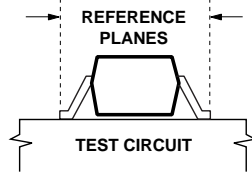

Figure 11. Reference Planes.

Since DC bias is applied to the MGA-86563 through the RF Output pin, some method of isolating the RF from the DC must be provided. An RF choke or length of high impedance transmission line is typically used for this purpose.

### SOT-363 PCB Layout

A PCB pad layout for the miniature SOT-363 (SC-70) package used by the MGA-86563 is shown in Figure 12 (dimensions are in inches). This layout provides ample allowance for package placement by automated assembly equipment without adding parasitics that could impair the high frequency RF performance of the MGA-86563. The layout is shown with a nominal SOT-363 package footprint superimposed on the PCB pads.

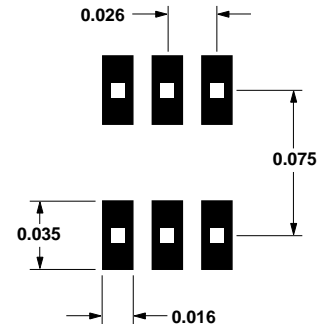

Figure 12. PCB Pad Layout (dimensions in inches).

### RF Layout

The RF layout in Figure 13 is suggested as a starting point for amplifier designs using the MGA-86563 MMIC. Adequate grounding is needed to obtain maximum performance and to obviate potential instability. All four ground pins of the MMIC should be connected to RF ground by using plated through holes (vias) near the package terminals.

It is recommended that the PCB pads for the ground pins NOT be connected together underneath the body of the package. PCB traces hidden under the package cannot be adequately inspected for SMT solder quality.

### PCB Material

FR-4 or G-10 printed circuit board material is a good choice for most low cost wireless applications. Typical board thickness is 0.020 or 0.031 inches. The width of 50  $\Omega$  microstriplines in PC boards of these thicknesses is also convenient for mounting chip components such as the series inductor that is used at the input for impedance matching or for DC blocking capacitors.

For applications requiring the lowest noise figures, the use of

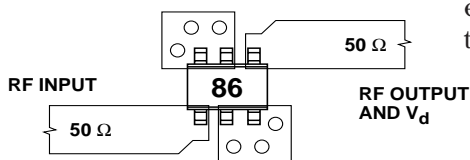

Figure 13. RF Layout.

PTFE/glass dielectric materials may be warranted to minimize transmission line losses at the amplifier input. A 0.5 inch length of 50  $\Omega$  microstripline on FR-4 has approximately 0.3 dB loss at 4 GHz which will add directly to the noise figure of the MGA-86563.

### Typical Application Circuit

A typical implementation of the MGA-86563 as a low noise amplifier is shown in Figure 14.

A 50  $\Omega$  microstripline with a series DC blocking capacitor, C1, is used to feed RF to the MMIC. The input of the MGA-86563 is already partially matched for noise figure and gain to 50  $\Omega$ . The use of a simple input matching circuit, such as a series inductor, will minimize amplifier noise figure. Since the impedance match for  $NF_0$  (minimum noise figure) is very close to a conjugate power match, a low noise figure can be realized simultaneously with a low input VSWR.

DC power is applied to the MMIC through the same pin that is shared with the RF output. A 50  $\Omega$  microstripline is used to connect the device to the following stage. A bias decoupling network is used to feed in  $V_d$  while simultaneously providing a DC block to the RF signal. The bias

decoupling network shown in Figure 14, consisting of resistor R1, a short length of high impedance microstripline, and bypass capacitor C3, will provide excellent performance over a wide frequency range. Surface mount chip inductors could be used in place of the high impedance transmission line to act as an RF choke. Consideration should be given to potential resonances and signal radiation when using lumped inductors.

For operation at frequencies below approximately 2 GHz, the addition of a simple impedance matching circuit to the output will increase the gain and output power by 0.5 to 1.5 dB. The output matching circuit will not effect the noise figure.

A small value resistor placed in series with the  $V_{dd}$  line may be useful to “de-Q” the bias circuit. Typical values of R1 are in the 10  $\Omega$  to 100  $\Omega$  range. Depending on the value of resistance used, the supply voltage may have to be increased to compensate for voltage drop across R1. The power supply should be capacitively bypassed (C3) to ground to prevent undesirable gain variations and to eliminate unwanted feedback through the bias lines that could cause oscillation.

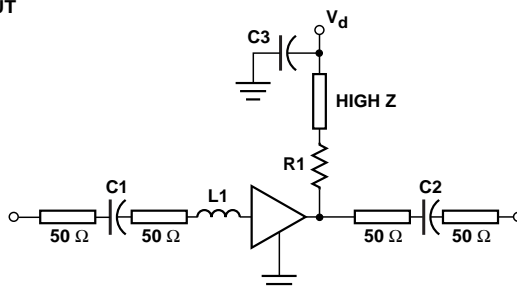

Figure 14. Typical Amplifier Circuit.

### Higher Bias Voltages

While the MGA-86563 is designed primarily for use in +5 volt applications, the internal bias regulation circuitry allows it to be operated with any power supply voltage from +5 to +7 volts. The use of +7 volts increases the  $P_{1dB}$  by approximately 1 dBm. The effect on noise figure, gain, and VSWR with higher  $V_d$  is negligible.

For more information call your nearest HP sales office.

### MGA-86563 Part Number Ordering Information

Part Number	Devices per Container	Container
MGA-86563-TR1	3000	7" reel
MGA-86563-BLK	100	Antistatic bag

### Package Dimensions

#### Outline 63 (SOT-363/SC-70)

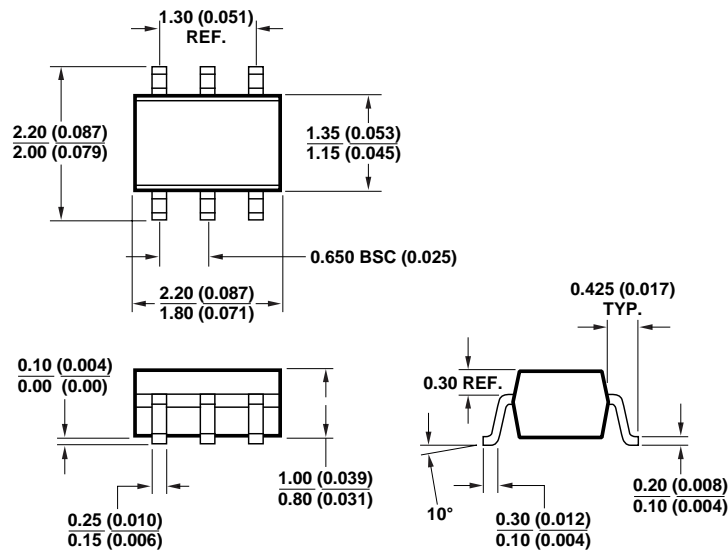

DIMENSIONS ARE IN MILLIMETERS (INCHES)

## Device Orientation

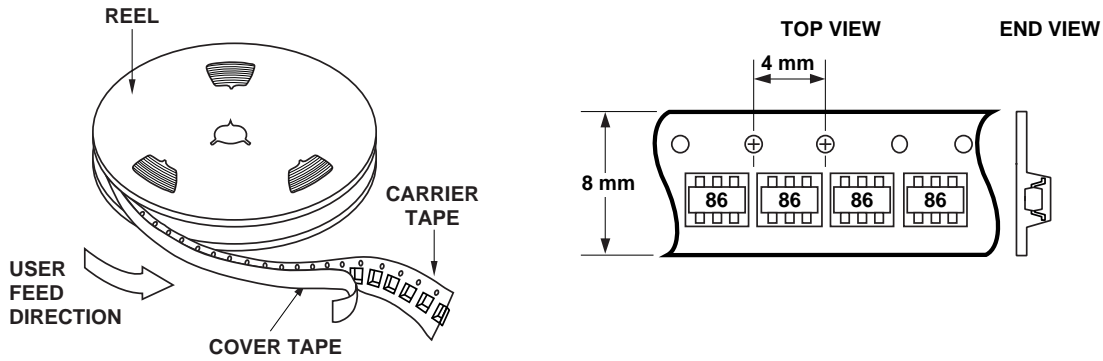

## Tape Dimensions and Product Orientation For Outline 63

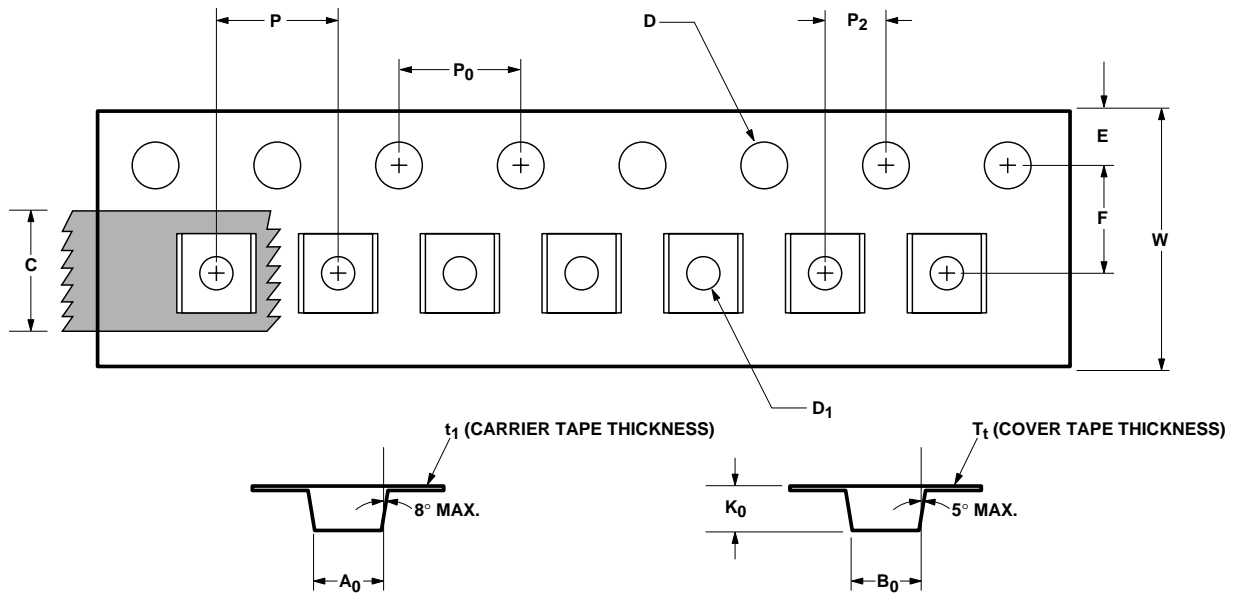

DESCRIPTION		SYMBOL	SIZE (mm)	SIZE (INCHES)
CAVITY	LENGTH	A <sub>0</sub>	2.24 ± 0.10	0.088 ± 0.004
	WIDTH	B <sub>0</sub>	2.34 ± 0.10	0.092 ± 0.004
	DEPTH	K <sub>0</sub>	1.22 ± 0.10	0.048 ± 0.004
	PITCH	P	4.00 ± 0.10	0.157 ± 0.004
	BOTTOM HOLE DIAMETER	D <sub>1</sub>	1.00 + 0.25	0.039 + 0.010
	PERFORATION	DIAMETER	D	1.55 ± 0.05
	PITCH	P <sub>0</sub>	4.00 ± 0.10	0.157 ± 0.004
	POSITION	E	1.75 ± 0.10	0.069 ± 0.004
CARRIER TAPE	WIDTH	W	8.00 ± 0.30	0.315 ± 0.012
	THICKNESS	t <sub>1</sub>	0.255 ± 0.013	0.010 ± 0.0005
COVER TAPE	WIDTH	C	5.4 ± 0.10	0.205 ± 0.004
	TAPE THICKNESS	T <sub>t</sub>	0.062 ± 0.001	0.0025 ± 0.00004
DISTANCE	CAVITY TO PERFORATION (WIDTH DIRECTION)	F	3.50 ± 0.05	0.138 ± 0.002
	CAVITY TO PERFORATION (LENGTH DIRECTION)	P <sub>2</sub>	2.00 ± 0.05	0.079 ± 0.002