

FEATURES

- 3.3V, 5V, 12V, and adjustable output versions
- Adjustable version output voltage range, 1.23V to 37V
± 3% max over line and load conditions
- Guaranteed 5A output load current
- Input voltage range up to 40V
- Requires only 4 external components
- 150kHz ±15% fixed frequency internal oscillator
- Excellent line and Load regulation specifications
- Low power standby mode, I_Q typically 80 μ A
- Thermal shutdown and current limit protection

APPLICATION

- Simple high-efficiency step-down regulator
- On-card switching regulators
- Positive to negative converter

DESCRIPTION

The LM1501A series of regulators are monolithic integrated circuits that provide all the active functions for a step-down switching regulator, capable of driving a 5A load with excellent line and load regulation. These devices are available in fixed output voltages of 3.3V, 5V, 12V and an adjustable output version. Requiring a minimum number of external components, these regulators are simple to use. The LM1501A series operates at a switching frequency of 150kHz. Available in standard 5-lead TO-263 and TO-220 package.

Other features include a guaranteed $\pm 3\%$ tolerance on output voltage under specified input voltage and output load conditions, and $\pm 15\%$ on the oscillator frequency. External shutdown is included, featuring typically 80 μ A standby current. Self protection features include a current limit for output switch and an over temperature shutdown for complete protection under fault conditions. The over temperature shutdown level is about 145 $^{\circ}$ C with 5 $^{\circ}$ C hysteresis.

Absolute Maximum Ratings ($T_A = 25^{\circ}\text{C}$) ^(Note 1)

Characteristic	Symbol	Value	Unit
Maximum Input Supply Voltage	V_I	45	V
ON/OFF Pin Input Voltage	V_{IN}	$-0.3 \leq V \leq +25$	V
Feedback Pin Voltage	V_{FB}	$-0.3 \leq V \leq +25$	V
Output Voltage to Ground	V_O	-1	V
Power Dissipation	P_D	Internally limited	W
Storage Temperature Range	T_{stg}	-65 to +150	$^{\circ}\text{C}$
Operating Temperature Range	T_J	$-40 \leq T_J \leq +125$	$^{\circ}\text{C}$
ESD Susceptibility (Human Body Model)	V_{ESD}	2	kV
Operating Supply Voltage	V_{IN}	4.5 to 45	V

Note 1. Absolute Maximum Rating indicate limits beyond which damage to device may occur. Operating Ratings indicate conditions for which the device is intended to be functional, but do not guarantee specific performance limits. For guaranteed specifications and test conditions, see the Electrical Characteristics.

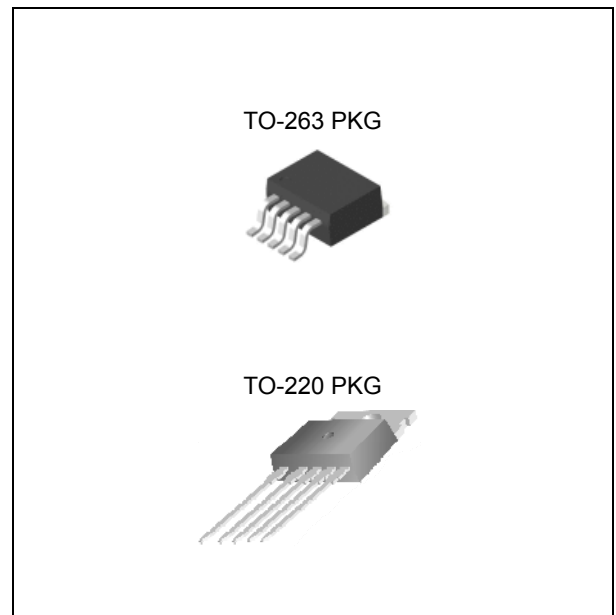
**Ordering Information**

Device(Marking)	PKG
LM1501AR-X.X	TO-263 5L
LM1501AT-X.X	TO-220 5L

X.X = Output Voltage = 3.3, 5.0, 12, ADJ

Ordering Information

V _{OUT}	Package	Order No.	Description	Package Marking	Supplied As
ADJ	TO-263 5L	LM1501AR-ADJ-5L	5A, 150KHz	LM1501A-ADJ	Reel
	TO-220 5L	LM1501AT-ADJ-5L	5A, 150KHz	LM1501A-ADJ	Tube
3.3V	TO-263 5L	LM1501AR-3.3-5L	5A, 150KHz	LM1501A-3.3	Reel
	TO-220 5L	LM1501AT-3.3-5L	5A, 150KHz	LM1501A-3.3	Tube
5.0V	TO-263 5L	LM1501AR-5.0-5L	5A, 150KHz	LM1501A-5.0	Reel
	TO-220 5L	LM1501AT-5.0-5L	5A, 150KHz	LM1501A-5.0	Tube
12V	TO-263 5L	LM1501AR-12-5L	5A, 150KHz	LM1501A-12	Reel
	TO-220 5L	LM1501AT-12-5L	5A, 150KHz	LM1501A-12	Tube

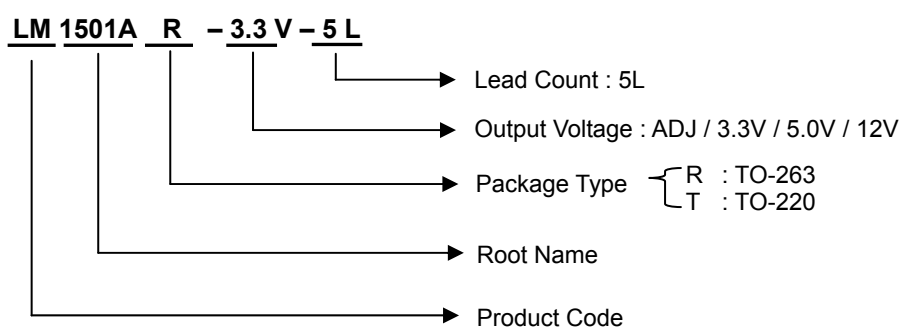

PIN CONFIGURATION



TO-263 5L

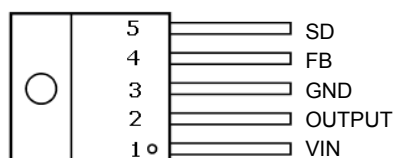

TO-220 5L

PIN DESCRIPTION

Pin No.	TO-263 / TO-220 5 LEAD	
	Name	Function
1	V _{IN}	Operating Input Voltage
2	OUTPUT	Switching Output Voltage
3	GND	Ground
4	FB	Output Voltage Feedback Control
5	SD	ON/OFF Shutdown

Electrical Characteristics

Unless otherwise specified, $T_J = 25^\circ\text{C}$ $V_{IN} = 12\text{V}$ for the 3.3V, 5V, and Adjustable version and $V_{IN} = 24\text{V}$ for the 12V version. $I_{LOAD} = 500\text{mA}$.

Characteristic	Symbol	Test Condition		Min	Typ	Max	Unit
Efficiency	η	LM1501A-ADJ	$V_{OUT} = 3\text{V}, I_{LOAD} = 5\text{A}$		73		%
		LM1501A-3.3	$V_{IN} = 12\text{V}, I_{LOAD} = 5\text{A}$		73		
		LM1501A-5	$V_{IN} = 12\text{V}, I_{LOAD} = 5\text{A}$		80		
		LM1501A-12	$V_{IN} = 25\text{V}, I_{LOAD} = 5\text{A}$		90		
Output Voltage	V_{OUT}	LM1501A-3.3	$4.75\text{V} \leq V_{IN} \leq 40\text{V}$ $0.2\text{A} \leq I_{LOAD} \leq 5\text{A}$	3.20	3.3	3.40	V
		LM1501A-5	$7\text{V} \leq V_{IN} \leq 40\text{V}$ $0.2\text{A} \leq I_{LOAD} \leq 5\text{A}$	4.85	5.0	5.15	
		LM1501A-12	$15\text{V} \leq V_{IN} \leq 40\text{V}$ $0.2\text{A} \leq I_{LOAD} \leq 5\text{A}$	11.64	12.0	12.36	
Feedback Voltage	V_{FB}	LM1501A-ADJ	$4.5\text{V} \leq V_{IN} \leq 40\text{V}$ $0.2\text{A} \leq I_{LOAD} \leq 5\text{A}$ V_{OUT} programmed for 3V	1.180	1.215	1.250	V
Oscillator Frequency	f_O			127	150	173	kHz
Feedback Bias Current	I_D	LM1501A-ADJ;	$V_{FB} = 1.215\text{V}$		15	50	
Saturation Voltage	V_{SAT}		$I_{OUT} = 5\text{A}$ (Note 2,3)			1.4	V
Max Duty Cycle (ON)	DC	(Note 3)			100		%
Max Duty Cycle (OFF)		(Note 4)			0		
Current Limit	I_{CL}		Peak Current (Note 2,3)		6.5		A
Output Leakage Current	I_L		Output = 0V			50	μA
			Output = -1V, $V_{IN} = 40\text{V}$		2	30	mA
Quiescent Current	I_Q	(Note 4)			4.5	10	mA
Standby Quiescent Current	I_{STBY}		ON/OFF pin = 5V(OFF), $V_{IN} = 40\text{V}$		80	200	μA
ON/OFF Pin Logic Input Threshold voltage					1.3		V
	V_{IH}		Low(Regulator ON)			0.6	
	V_{IL}		High (Regulator OFF)	2.0			
ON/OFF Pin Logic Input current	I_H		$V_{LOGIC} = 2.5\text{V}$ (regulator OFF)		5	15	μA
	I_L		$V_{LOGIC} = 0.5\text{V}$ (regulator ON)			5	

Note 2. No elements connected to output pin

Note 3. Feedback pin removed from output and connected to 0V to force the output transistor switch ON.

Note 4. Feedback pin removed from output and connected to 12V for the 3.3V, 5V, and the A version, and 15V for the 12V version. To force the output transistor switch OFF

TYPICAL APPLICATION

- Fixed Application Circuit

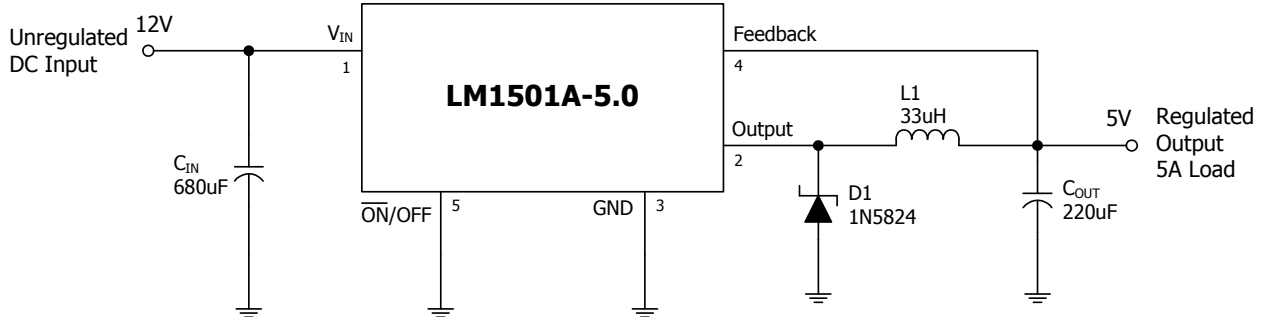

- Adjustable Application Circuit

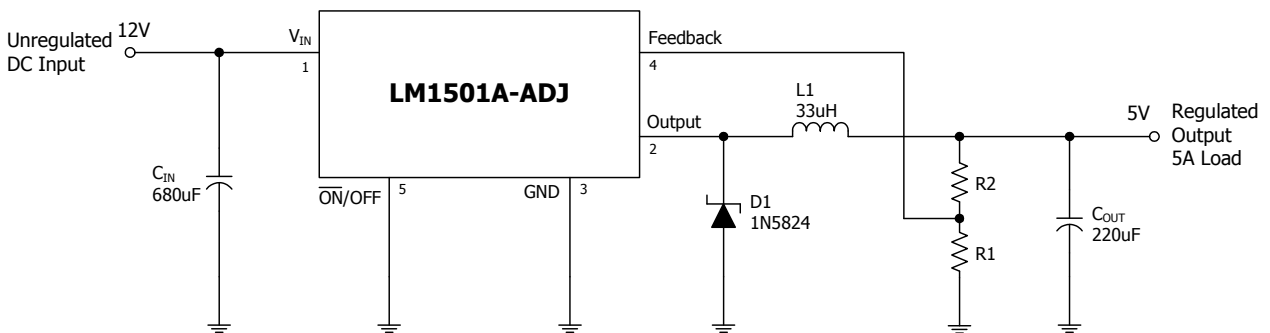

TYPICAL OPERATING CHARACTERISTICS

T.B.D

APPLICATION INFORMATION

T.B.D