

Synchronous Rectification DC-DC Converter Power IC

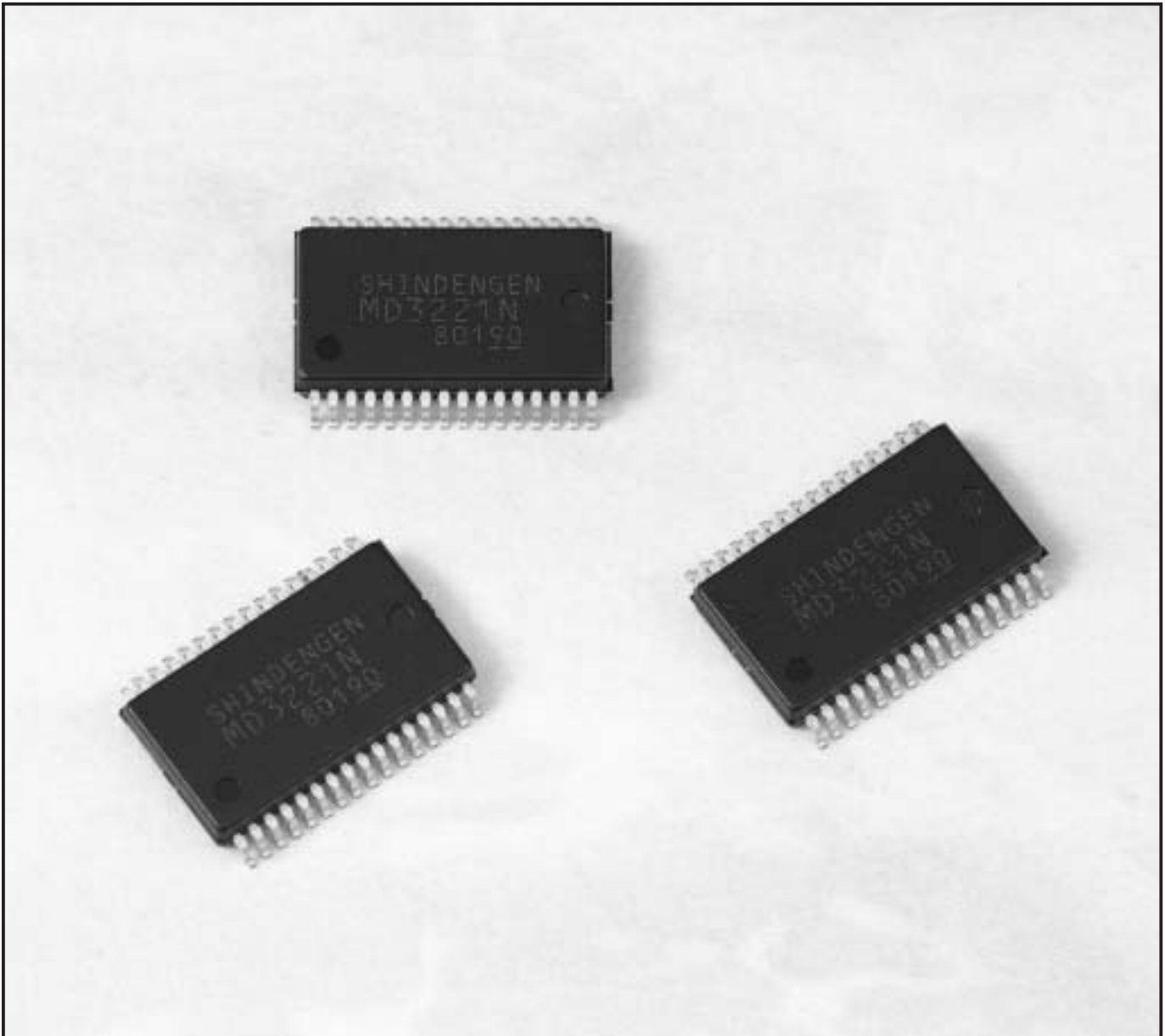

MD3221N







Application Manual



1 Using the MD3221N DC to DC Converter Power IC

Thank you for purchasing the MD3221N DC to DC Converter Power IC. This manual contains important information on the safe use of the MD3221N. Your safety is most important to our company. Please read these instructions carefully before using this device.

<p>CAUTION </p>	<p>The improper use of this device can result in serious injury or death. Expensive damage to this and other equipment can result. Failure to observe the cautions in this Manual can also result in minor injuries and annoying equipment damage.</p>
---	--

<p>CAUTION</p>	<p> The MD3221N is intended for use with general electronic equipment (office automation, communication, measurement, household, etc.) It is not intended for use with equipment whose failure might result in the death or injury of those depending upon it (medical treatment, air navigation, railroad, cargo handling, nuclear power, etc.) If you intend to use the MD3221N with other than the general equipment listed above, please consult with our company.</p> <p> Under no conditions attempt to repair or modify this device by yourself. Doing so can result in electric shock, equipment breakage, fire, and unreliable (and dangerous) equipment operation.</p> <p> Abnormal operating conditions may result in excessive voltage at the output terminal or excessive voltage drops elsewhere in the device. Take steps to prevent load mishandling and breakage (overvoltage and overcurrent prevention) at the final point in the equipment chain.</p> <p>Overvoltage protection  The MD3221N is not equipped with an overvoltage protection function. In the event excessive voltage appears within a module, the high input voltage may remain together with a high output voltage even when the equipment is turned off. Smoke and flame may appear. To prevent this, be sure to install some sort of overvoltage protection circuitry before using the equipment.</p> <p> Before providing electrical power to the device, check that the polarity of the input and output terminals is correct (check for misconnections). If circuit protection circuitry is cut off from the rest of the equipment, smoke and flames may appear.</p> <p> Be sure that input voltage level is maintained at the specified level. This may require the installation of a voltage regulator to the input line. Voltage fluctuations may result in the appearance of smoke and flames.</p> <p> If a breakdown or other abnormal condition occurs during equipment use, immediately stop power to the equipment. Contact our company at your earliest possible convenience.</p>
-----------------------	---

- The information appearing in this Manual is the latest available at the time of publication. We reserve the right to make changes to the device without prior notice. Therefore, your device may differ slightly from that described in this Manual.
- Every effort has been made to make the information in this Manual accurate and reliable. However, our company takes no responsibility for injuries or damage incurred when using the device as described in this Manual. Neither do we take responsibility for damages incurred as a result of patent or other defined rights.
- We do not give consent for a third person to use our patent or other rights based on this material. We do not guarantee these rights.
- No part of this material may be reproduced or copied without the specific written consent of our company.
- This device fully meets the reliability and quality control standards described in our company's catalog. If this device is to be used in a situation where its misuse or failure might cause serious injury or death, consult with our company.
- Reliability and quality control standards for this device are considered adequate when it is used with the following types of end equipment.
Computer - Office automation - Communication terminal - Measurement · Machine tools - Audio-visual - Games and other amusements - Household appliance - Personal items - Industrial robot.
Special applications where the device may or may not be suitable include the following.
Transportation and conveyance (cargo loading) equipment- Primary communications equipment - Traffic signal control equipment - Fire and burglary alarms - Various safety devices - Medical equipment
Other special applications where the device reliability is not considered high enough include the following.
Atomic energy control systems - Aviation equipment- Aeronautics and space equipment - Ocean depth sounding equipment - Life supportequipment
- Our company makes a constant effort to improve the quality and reliability of our products. However, it is the customer's responsibility to provide safety. Take the appropriate steps to prevent personal injury, fire, and damage by providing redundancy equipment, fire containment equipment, and devices to protect personnel and equipment from operational mistakes.

Contents

↓ Click!

<p>1 Cautions for Use..... 1</p> <p>2 Outline 3</p> <p style="padding-left: 20px;">Features</p> <p style="padding-left: 20px;">Product Code</p> <p style="padding-left: 20px;">Standard Connection Diagram</p> <p style="padding-left: 20px;">Pin Layout</p> <p style="padding-left: 20px;">Pin Functions</p> <p>3 Specifications 5</p> <p style="padding-left: 20px;">Absolute maximum ratings</p> <p style="padding-left: 20px;">Recommended Operating Conditions</p> <p style="padding-left: 20px;">Electrical Characteristics</p> <p style="padding-left: 20px;">Internal Block Diagrams</p> <p>4 Selection of Primary Components and Pin Connections ... 7</p> <p style="padding-left: 20px;">Selecting the Output Choke Coil</p> <p style="padding-left: 20px;">Selecting the Output Condenser</p> <p style="padding-left: 20px;">Selecting the Input Condenser</p> <p style="padding-left: 20px;">Selecting the Regenerative Diode</p> <p>5 Functions 10</p> <p style="padding-left: 20px;">Setting the Output Voltage</p> <p style="padding-left: 20px;">Selecting the Oscillation Frequency</p> <p style="padding-left: 20px;">The Soft Start Function</p> <p style="padding-left: 20px;">The Remote ON/OFF Function</p> <p style="padding-left: 20px;">The Reference Voltage</p> <p style="padding-left: 20px;">The Over-current Protection Function</p> <p style="padding-left: 20px;">Short-circuit Protection</p> <p style="padding-left: 20px;">The Current Limiting Function</p> <p style="padding-left: 20px;">The Overheat Protection Function</p> <p style="padding-left: 20px;">Error Amp Gain Adjustment</p> <p style="padding-left: 20px;">Bootstrap</p> <p style="padding-left: 20px;">The L Cut (cut off detect) Function</p>	<p>6 Cautions for Pattern Design 16</p> <p style="padding-left: 20px;">Primary Circuit Pattern Design</p> <p style="padding-left: 20px;">Control Circuit Pattern Design</p> <p>7 Application Circuit Examples ... 17</p> <p style="padding-left: 20px;">Component Examples</p> <p>8 Dimension Drawing 18</p> <p>9 Mounting..... 19</p> <p style="padding-left: 20px;">Substrate Mounting Example</p> <p style="padding-left: 20px;">Cautions for Mounting</p> <p>10 External Protection Circuits ... 20</p> <p style="padding-left: 20px;">Connection of Input Protection Devices</p> <p style="padding-left: 20px;">Connection of Over-voltage Protection Circuit</p> <p>11 Characteristics 21</p> <p style="padding-left: 20px;">Output voltage : 3.3V</p> <ul style="list-style-type: none"> • Efficiency and Loss Characteristics • Line Regulation • Load Regulation • Temperature Characteristics • Start-up Characteristics • R/C Start-up Characteristics <p style="padding-left: 20px;">Efficiency by Output Voltage</p> <ul style="list-style-type: none"> • Efficiency by Output Voltage <p style="padding-left: 20px;">Efficiency at Frequency of 100KHz</p> <ul style="list-style-type: none"> • Efficiency and Losses <p>12 Packaging..... 23</p> <p style="padding-left: 20px;">Tape and Reel</p> <p style="padding-left: 20px;">Packing</p> <p style="padding-left: 20px;">Ordering and Dimensions</p>
---	---

2 Outline

The MD3221N is a non-insulated DC-DC converter power IC incorporating a dedicated main switch MOSFET and a synchronous rectification MOSFET. Integration of a control IC and a power device in a single chip minimizes the effects of wiring and simplifies large-current power supply circuit design. The PWM-controlled output voltage may be set over a wide range of 0.8V to 14V, and 2.5V/3.3V may be set without the use of an external resistor. A wide range of input voltages (4.5V to 20V) are possible, and 5V input and battery input are also accommodated. An over-current protection circuit is incorporated to detect voltage drop with the ON resistance of the internal MOSFET and thus provide a simple DC-DC converter of high efficiency. The oscillation frequency is selected from the 100kHz or 300kHz set internally, not only reducing the number of external components required, but also facilitating flexible design in applications. A surface mount S/SOP32 package is used to ensure a small and thin power supply circuit.

◆ Features

- Input voltage range of 4.5V to 20V.
- Adjustable output voltage range of 0.8V to 14V.
- Internal power MOSFET
- High efficiency of 96% ($V_i=5V$, $V_o=3.3V$, $I_o=1A$)
- Over-Current protection function (external resistor not required)
- Over temperature protection function
- Remote ON/OFF function
(current consumption at OFF: Typ. 25 μ A)
- Switching frequency of 100kHz or 300kHz
(external C.R not required)
- The L Cut (Cut off direct) function
- Ambient temperature range: -30°C to 85°C

◆ Product Code

MD3221N 4072

Specification code
Product name

◆ Standard Connection Diagram

● Basic Circuit

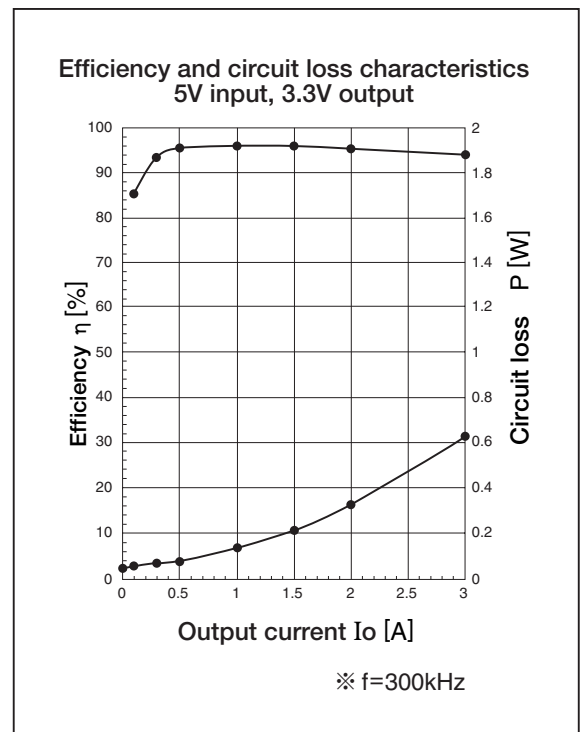
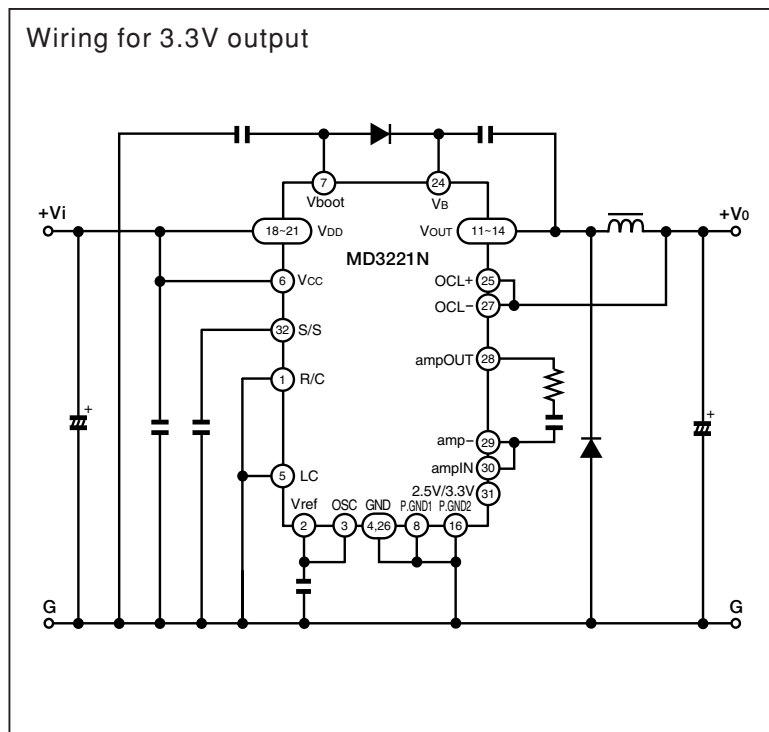

◆ Pin Layout

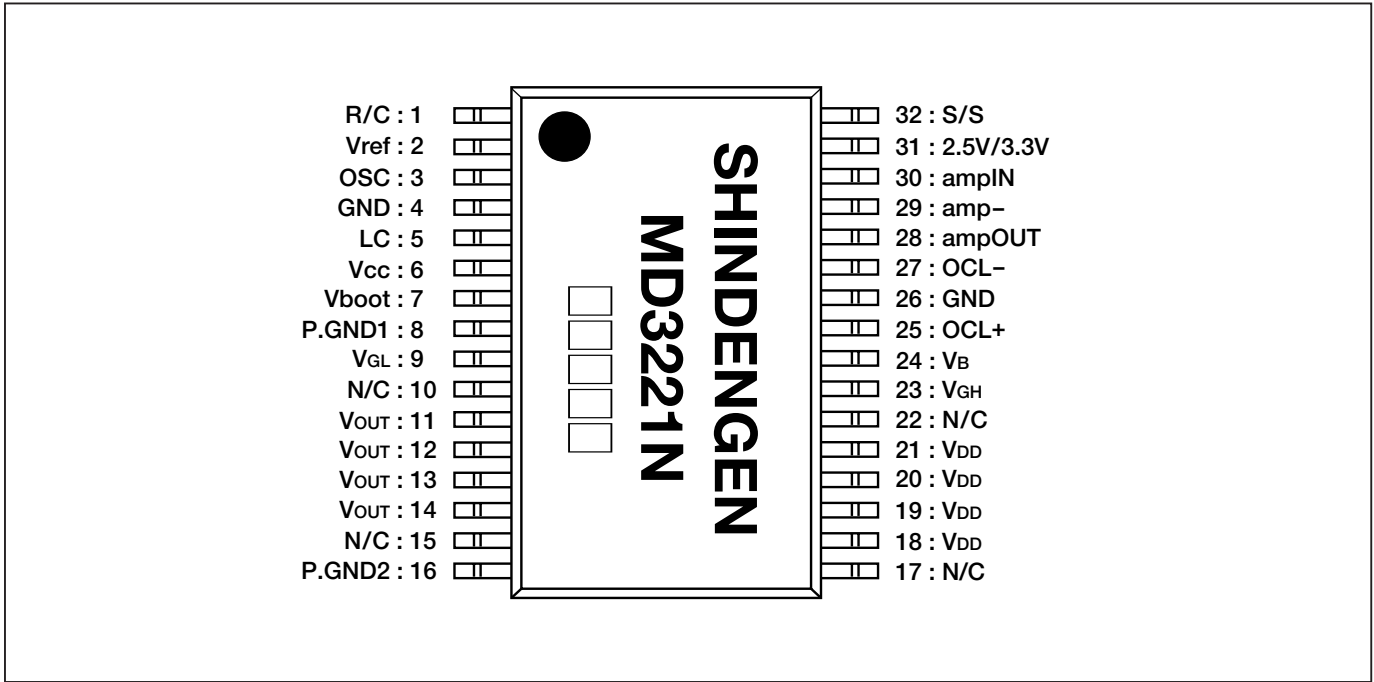

◆ Pin Functions

Pin number	Symbol	Function description
1	R/C	Remote ON/OFF control
2	Vref	Internal reference voltage output
3	OSC	Oscillation frequency select
4,26	GND	Control circuit GND
5	LC	Cut-off detect select
6	Vcc	Control circuit power supply
7	Vboot	Low side MOSFET drive circuit power supply
8	P.GND1	Low side MOSFET drive circuit GND
9	VGL	Low side MOSFET gate. Please do not connect the pin anywhere.
11~14	VOUT	Output
16	P.GND2	Low side MOSFET sources
18~21	VDD	High side MOSFET power supply
23	VGH	High side MOSFET gate. Please do not connect the pin anywhere.
24	VB	High side MOSFET drive circuit power supply
25	OCL+	Over-current +ve detect at external resistance detection
27	OCL-	Over-current -ve detect at external resistance detection
28	ampOUT	Internal error amplifier output
29	amp-	Internal error amplifier inverted input
30	ampIN	Internal voltage detect resistor output
31	2.5V/3.3V	2.5V/3.3V output select
32	S/S	Soft start condenser connection
10,15,17,22	N/C	Non-connection (not connected internally)

Refer to '7. Selection of Primary Components and Pin Connections' and '10. Functions' for function descriptions and pin connections.

3 Specifications

◆ Absolute maximum ratings

Power supply voltage (voltage at V _{CC})	22V
High side MOSFET input voltage	22V
Average output current	3A
Peak output current	4A
Voltage between V _B and V _{OUT}	5.5V
Allowable applied output current at V _{boot}	-30mA
Allowable applied current at V _{ref}	-3mA
Storage temperature	-50~150°C
Temperature at contacts	150°C

◆ Recommended Operating Conditions

Input voltage range	4.5~20V
Settable output voltage range	0.8~14V
Ambient temperature range	-30~85°C

◆ Electrical Characteristics

T_a=25°C unless specified otherwise.

Item	Condition	Min.	Typ.	Max.	Unit
High side MOSFET					
Drain-source breakdown voltage	I _D =1mA, V _{GS} =0V	22	—	—	V
Drain breaking current	V _{DS} =22V, V _{GS} =0V	—	—	10	μA
Drain-source ON resistance	I _D =1.2A, V _{GS} =4.5V	—	22	55	mΩ
Source-drain diode forward voltage	I _S =1.2A, V _{GS} =0V	—	—	1.5	V
Low side MOSFET					
Drain-source breakdown voltage	I _D =1mA, V _{GS} =0V	22	—	—	V
Drain breaking current	V _{DS} =22V, V _{GS} =0V	—	—	10	μA
Drain-source ON resistance	I _D =1.2A, V _{GS} =4.5V	—	22	55	mΩ
Source-drain diode forward voltage	I _S =1.2A, V _{GS} =0V	—	—	1.5	V
Control IC current consumption					
Current consumption (at f=100kHz)	V _{CC} =4.5~20V	—	3.3	3.9	mA
Current consumption (at f=300kHz)	V _{CC} =4.5~20V	—	5	5.9	mA
Current consumption (remote OFF)	V _{CC} =4.5~20V	—	25	50	μA
UVLO					
Start-up voltage	—	4.1	4.3	4.5	V
Stop voltage	—	3.6	3.8	4.0	V
Start-up-stop voltage hysteresis	—	—	0.5	—	V
Bootstrap					
BOOT pin voltage	V _{CC} =5V	3.84	4	4.16	V
Power supply voltage variation	V _{CC} =4.5~20V	—	—	30	mV
Voltage load variation	V _{CC} =5V	—	—	30	mV
Reference voltage					
Internal reference voltage	V _{CC} =5V	3.84	4	4.16	V
Power supply voltage variation	V _{CC} =4.5~20V	—	—	30	mV
Voltage load variation	V _{CC} =5V	—	—	30	mV
Oscillator circuit					
Internal oscillation frequency 1 (f=100kHz)	V _{CC} =5V	85	100	115	kHz
Internal oscillation frequency 2 (f=300kHz)	V _{CC} =5V	255	300	345	kHz
Maximum duty ratio (f=300kHz)	V _{CC} =5V	85	90	95	%
Remote control					
Remote ON voltage	V _{CC} =5V	-0.2	—	0.7	V
Remote OFF voltage	V _{CC} =5V	2	—	V _{CC}	V
Short-circuit current	V _{CC} =5V	—	2	10	μA

Item	Condition	Min.	Typ.	Max.	Unit
Soft start					
Current at soft start pin	V _{cc} =5V	-3	-2.5	-2	μA
Error amp					
Error amp reference voltage	V _{cc} =5V	0.784	0.800	0.816	V
Over-Current protection detector					
Threshold current at ON resistance detection	V _{cc} =5V	3	—	—	A
Threshold voltage at external resistance detection	V _{cc} =5V	85	100	115	mV
Timer latch circuit					
Timer current	V _{cc} =5V	-40	-33	-26	μA
Voltage at S/S pin prior to timer operation	V _{cc} =5V	2.75	2.9	3.05	V
Latch threshold voltage	V _{cc} =5V	3.3	3.45	3.6	V
Output voltage detector					
Output voltage detect accuracy (set at 0.8V)	V _{cc} =4.5~20V	0.784	0.800	0.816	V
Output voltage detect accuracy (set at 2.5V)	V _{cc} =4.5~20V	2.425	2.500	2.575	V
Output voltage detect accuracy (set at 3.3V)	V _{cc} =4.5~20V	3.200	3.300	3.400	V
Over temperature protection detector					
Overheat protection operation temperature	—	—	140	—	°C

◆ Internal Block Diagrams

● Block Diagram

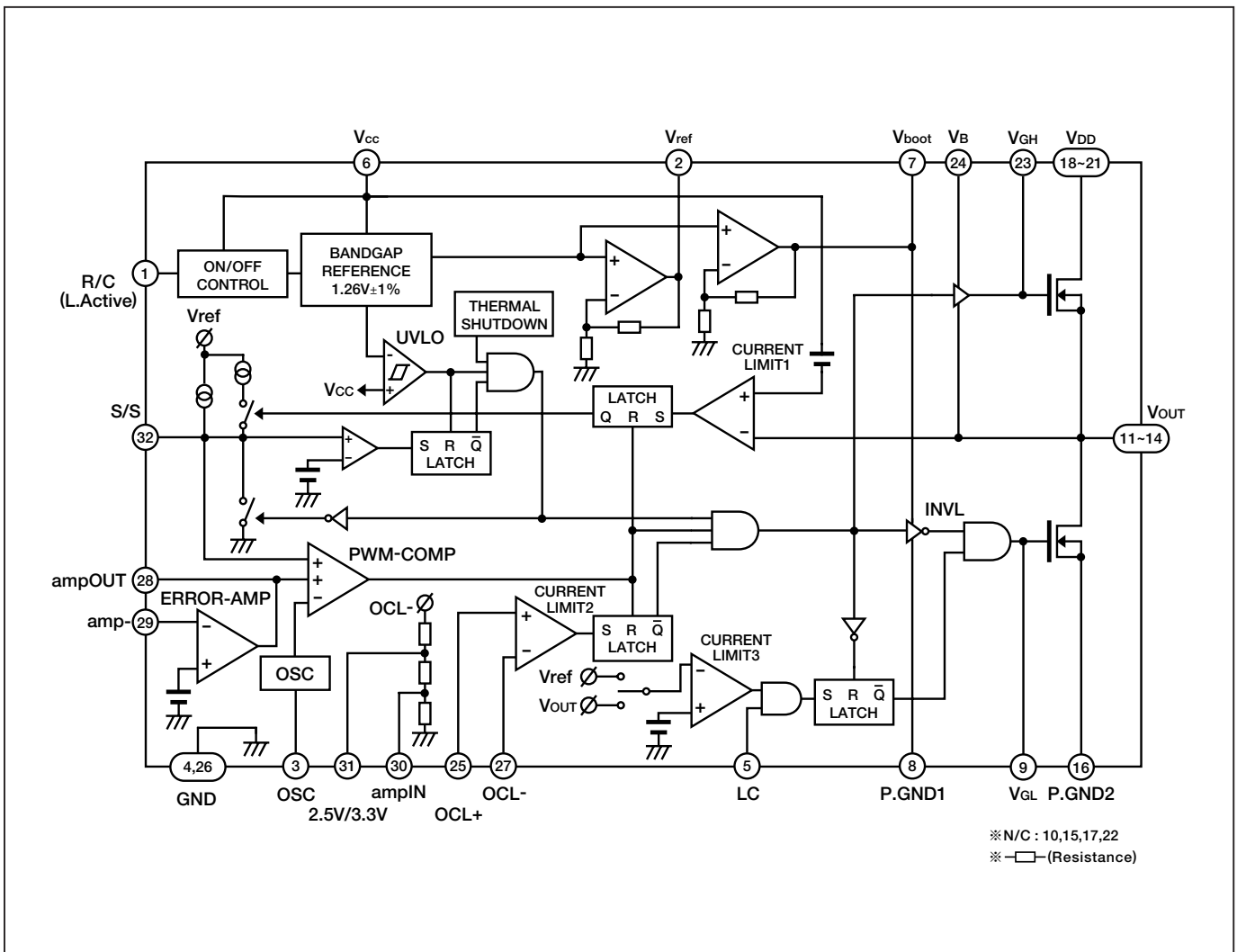

4 Selection of Primary Components and Pin Connections

The characteristics of the DC-DC converter are influenced by the IC itself, and also significantly by the peripheral components of the circuit.

A well-designed circuit is necessary to make the most of the potential of the MD3221N. It is therefore necessary to clarify the specifications of the required power supply, and to select components as follows.

● Standard Connection Diagram

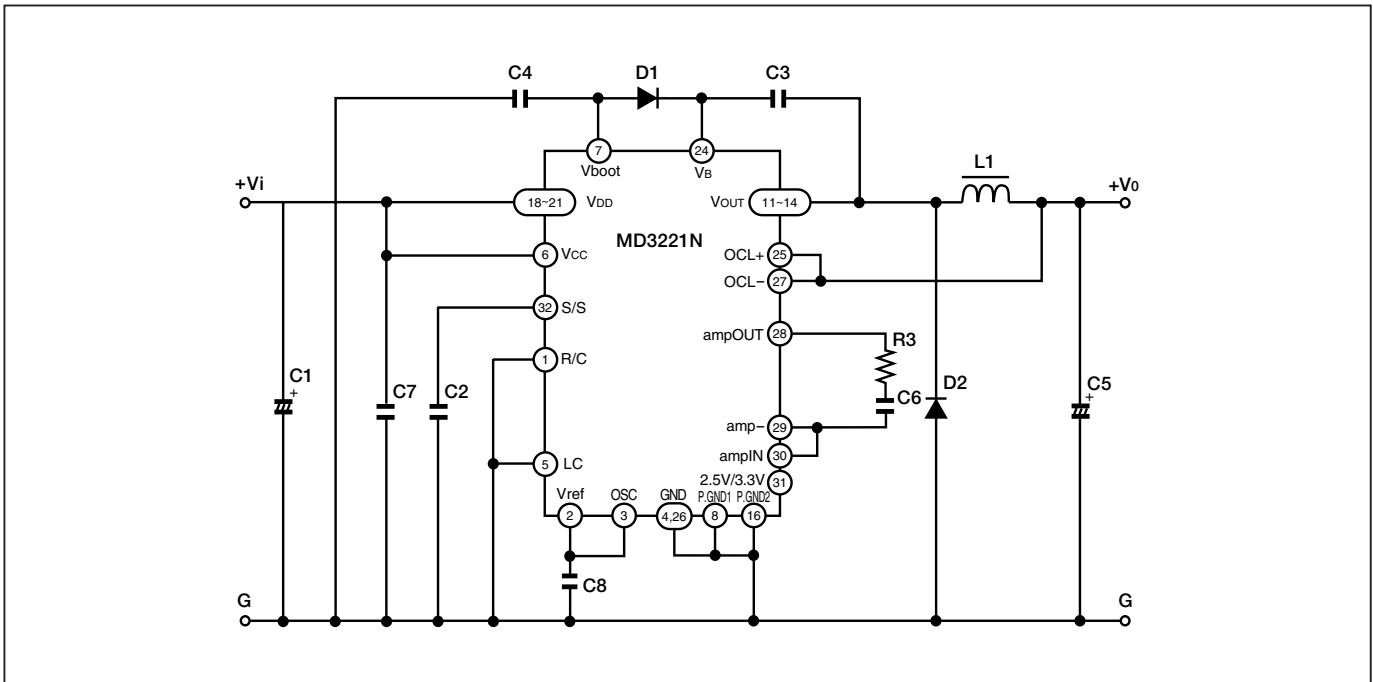

◆ Selecting the Output Choke Coil (inductor) (L1)

The choke coil has an important effect on power supply performance. As a ripple current flows in the inductor as shown in the diagram below, the inductance should be selected to ensure that ΔI is approximately 30% of the maximum output current when the input voltage is at its maximum.

$$L1 = \frac{(Vi_{(max)} - Vo) \times Vo}{\Delta I \times Vi_{(max)} \times f} \text{ [H]}$$

- $Vi_{(max)}$: Maximum input voltage [V]
- Vo : Output voltage [V]
- ΔI : 30% of maximum output current [A]
- f : Oscillation frequency (100kHz or 300kHz) [Hz]
- Io : Maximum output current [A]

● Current Waveform in Output Choke Coil (L1)

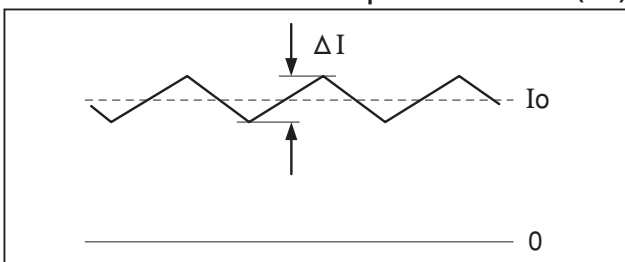

The inductor is generally selected on the basis of the calculation, however in some cases the nature of the product may require an inductor which differs from the calculated value. An inductor in which ΔI is between 20% and 40% of the output current is recommended.

If a higher inductance value is selected the output ripple voltage is reduced, however as the current rating drops the size of the required inductor is increased. On the other hand, if a lower inductance value is selected the size of the required inductor is reduced while peak current is increased, thus slightly increasing the loss when a load is applied.

While the MD3221N incorporates an over-current protection function, the inductor selected must be such that magnetic saturation does not occur at the over-current detection point.

As a magnetic field is generated in the vicinity of the inductor, component layout and pattern design must be such as to ensure that they do not affect the control circuit. Toroidal or closed magnetic circuit pot type inductors are recommended for applications likely to be affected by magnetic field leakage and radiated noise.

◆Selecting the Output Condenser (C5)

An output condenser is required to reduce output ripple and thus obtain a stable DC voltage. The converter output ripple voltage is determined by ΔI and condenser impedance. The output condenser is selected in relation to the impedance. Select the output condenser based on the desired output ripple voltage using the following equation.

$$Z_c \leq \frac{V_{rip}}{\Delta I} [\Omega]$$

Z_c : Condenser impedance [Ω]

V_{rip} : Output ripple voltage [V]

ΔI : 30% of maximum output current [A]

The desired ripple voltage is obtained if a condenser with an impedance less than that calculated with the above equation is selected from the catalog.

In addition to a low impedance, the output condenser must also have a reasonable capacitance. Control will readily become unstable and amp gain

adjustment will prove difficult if capacitance is low. Aluminum electrolytic condensers and functional high-polymer electrolytic condensers are of sufficiently high capacitance so that it need not be considered when selecting on the basis of the equation above. The use of such condensers, rather than ceramic or film condensers, is therefore recommended. On the other hand, concurrent use of ceramic or film condensers is effective in eliminating high frequency noise.

◆Selecting the Input Condenser (C1)

As a large ripple current flows in the input condenser it is necessary to consider the allowable value for ripple current. Select an input condenser with an allowable ripple current exceeding the value calculated in the equation below.

$$I_{rip} \geq \sqrt{D(1-D)} \times I_o [A]$$

$$D = \frac{V_o}{V_i}$$

I_{rip} : Allowable ripple current [A]

V_o : Output voltage [V]

V_i : Input voltage [V]

D : Duty ratio

I_o : Output current [A]

D is the ratio between the ON interval and the OFF interval, and I_{rip} is at a maximum when this value is 0.5. The capacitance of the input condenser need not be particularly high, however care is required if a ceramic or film condenser is used. As large ripple voltages are generated in the input condenser during charging and discharge, a particularly low input voltage may result in operation becoming unstable. As this ripple voltage is returned to the input line other circuits powered from the same line may be affected. Interference may occur, particularly when using multiple DC-DC converters, and in such cases an inductor of a few μH is inserted in the stage before the input condenser to eliminate the problem.

The substrate wiring between the input condenser to V_{DD} and P.GND2 is subject to the greatest variation in current, and wiring design should therefore focus primarily on reducing its impedance to the absolute minimum. Refer to '16. Cautions for Pattern Design' for details.

◆ Selecting the Regenerative Diode (D2)

The MD3221N employs synchronous rectification using a regenerative MOSFET, and requires a diode to bypass the regenerative current during the dead-time interval. If this diode is not present regenerative current flows in the MOSFET body diode during the dead-time interval, resulting in increased losses and noise. A Schottky barrier diode with low V_F is ideal for use in preventing current flowing in the body diode, however it is important that this diode has a low leakage current to prevent thermal runaway.

Recommended component :

D1FM3 (Shindengen)

30V, 3A $V_F=0.4V_{(max)}$ $I_R=0.1mA_{(max)}$

M1FM3 (Shindengen)

30V, 2.1A $V_F=0.4V_{(max)}$ $I_R=0.05mA_{(max)}$

5 Functions

◆Setting the Output Voltage

MD3221N output voltage may be set between 0.8V and 14V. When set to 2.5V or 3.3V the internal dividing resistor is used and an external resistor is not required. Output voltage is set with a minimum accuracy of $\pm 3\%$.

●Wiring for 2.5V Output

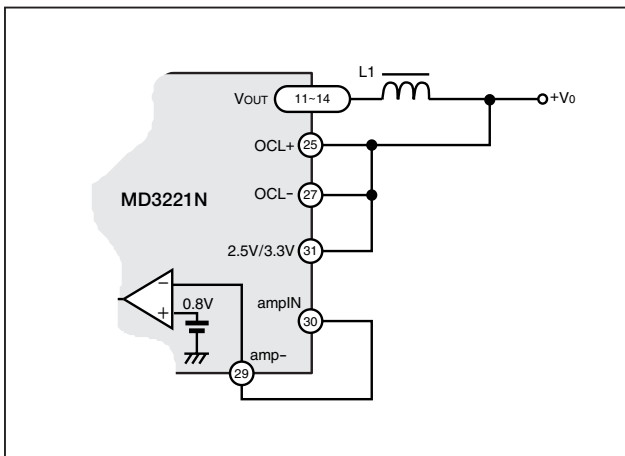

●Wiring for 3.3V Output

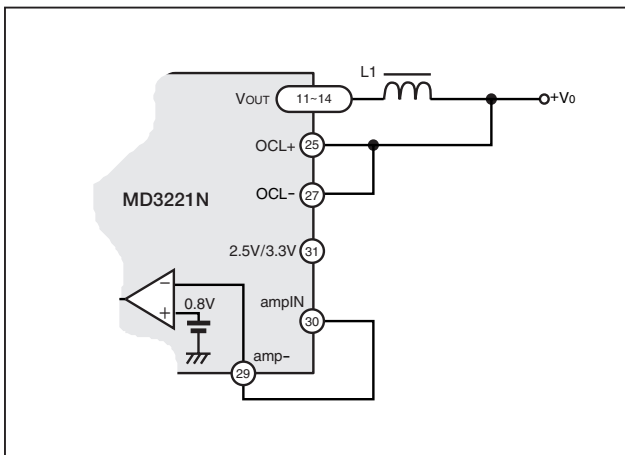

The internal dividing resistor is connected across the OCL and GND pins, with the dividing point connected to the ampIN pin. The ampIN pin should therefore be connected to the amp- pin externally.

An external dividing resistor is required if output voltage is to be set to other than 2.5V or 3.3V. As the error amp reference voltage is 0.8V the value for the dividing resistor is determined with the equation below.

$$R5 = 1k [\Omega]$$

$$R4 = \frac{R5 \times (Vo - 0.8)}{0.8} [\Omega]$$

Vo : Output voltage [V]

As the reference voltage has a minimum accuracy of $\pm 2\%$. The accuracy of the set output voltage is determined by the accuracy of the reference voltages and the accuracy of the resistor.

●Wiring for Variable Output

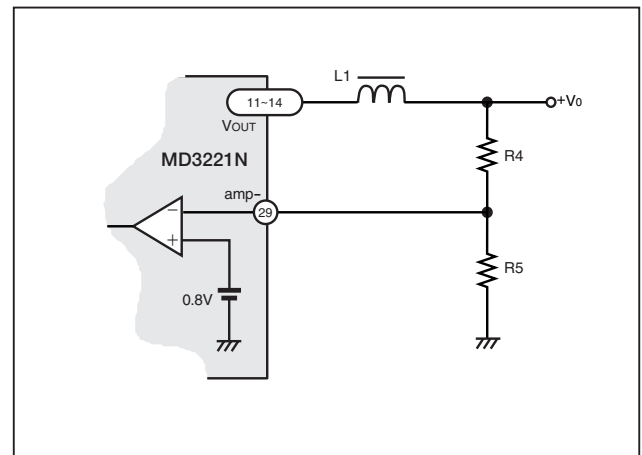

◆Selecting the Oscillation Frequency

The MD3221N incorporates an internal oscillator, and an external C.R is therefore not required. The oscillation frequency may be set to either 100kHz or 300kHz.

Switching losses in switching power supplies generally increase as the oscillation frequency increases, however the MD3221N is designed to provide sufficiently high efficiency at 300kHz. Furthermore, the number of peripheral components (eg the inductor) is minimized, and thus a standard circuit using the 300kHz frequency provides benefits in terms of both cost and space. Use of the 100kHz frequency is effective in terms of reducing high-frequency noise, and is more effective than the 300kHz frequency at low-load at which switching losses dominate.

The OSC pin is used in setting the oscillation frequency. The 300kHz frequency is selected by connecting the OSC pin to the Vref pin, and 100kHz by connecting it to the GND pin.

● Frequency Switching

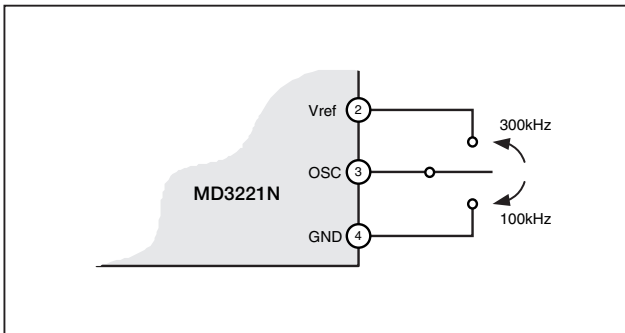

◆ The Soft Start Function

The MD3221N incorporates a soft start function to prevent overshoot at start-up and to reduce electrical stress on the device. As shown in the diagram below, the condenser (C2) is connected across the S/S and GND pins. As the duty ratio is limited by the voltage at the S/S pin, gradual charging of this condenser allows a fixed rate of increase in the output voltage.

● Soft Start Circuit

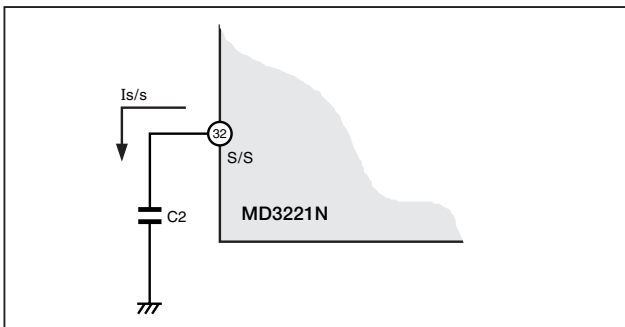

As shown in the diagram, the S/S pin is charged at a fixed current. When the voltage at this pin reaches 0.5V, main switch oscillation begins and output voltage increases. As the voltage at the S/S pin increases to a constant value of 2.9V the output voltage must reach the set voltage during that interval. If the capacitance of the output condenser is too high, the increase in the output voltage does not follow the increase at the S/S pin, thus preventing start-up in some cases.

● Relationship Between Soft Start Voltage and Input/Output Voltage

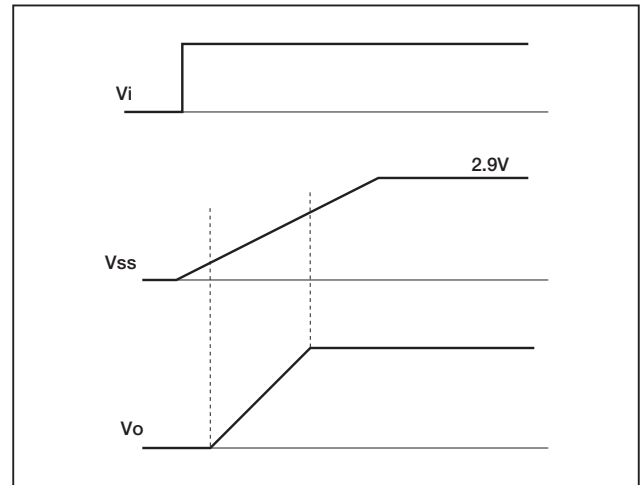

It is necessary to monitor output voltage V_o is always started up in advance to the S/S terminal voltage. (Refer to the chart above)

As shown in the graph below, the capacitance of the condenser connected to the S/S pin determines the start-up time.

● Relationship Between S/S Condenser and Output Voltage Start-up Time

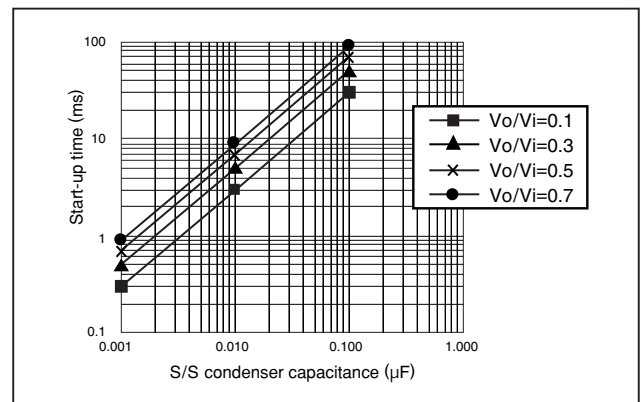

Select a high value for capacitance of the condenser connected to the S/S pin if latch is halted at start-up.

◆ The Remote ON/OFF Function (R/C)

An external signal may be used for ON/OFF control of the MD3221N. The MD3221N is switched ON when the R/C pin is set to L (0.7V or lower), and switched OFF when it is set to H (2V or higher), or is open. Current consumption at OFF is approximately $25\mu\text{A}$.

As the R/C pin is pulled up internally it may be used as an open collector, thus eliminating the need for application of an external voltage. Any external

voltage applied must be no higher than V_{CC} . When the remote ON/OFF function is used, a condenser is connected across the R/C and GND pins to prevent malfunctioning due to noise. If the capacitance of this condenser is too high, the output voltage will be produced instantaneously when an input voltage is applied while the MD3221N is OFF. The capacitance of this condenser should be approximately 1/3 of that of the S/S condenser (C2) as obtained from the graph in 'Soft Start Function' (P11).

● Remote Control Circuit

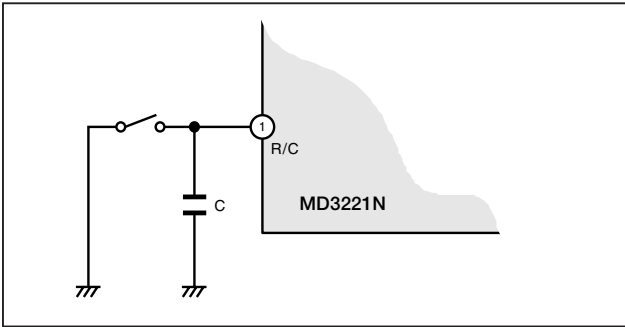

◆ The Reference Voltage (V_{ref})

The MD3221N provides an internal temperature compensated reference voltage (4V) which may be used as a reference voltage up to 1mA for external circuits. A condenser (C8) of approximately $0.1\mu F$ is connected across the V_{ref} and GND pins to prevent malfunctioning due to noise.

* Note that this voltage differs from the error amp reference voltage.

◆ The Over-current Protection Function (timer latch)

The MD3221N incorporates an over-current protection function. As the over-current condition is detected with the use of the voltage drop resulting from the ON resistance of the internal MOSFET, an external detection resistance is not required. When the over-current condition is detected the condenser (C2) connected to the S/S pin is charged again, and when a level of 3.45V is reached the latch is halted.

To turn the timer latch off, use the R/C function to switch OFF the MD3221N, or switch OFF the power supply voltage.

This function also employs the S/S pin condenser as a timer. Determine the capacitance of this condenser in reference to the section on soft start.

● Over-current Protection

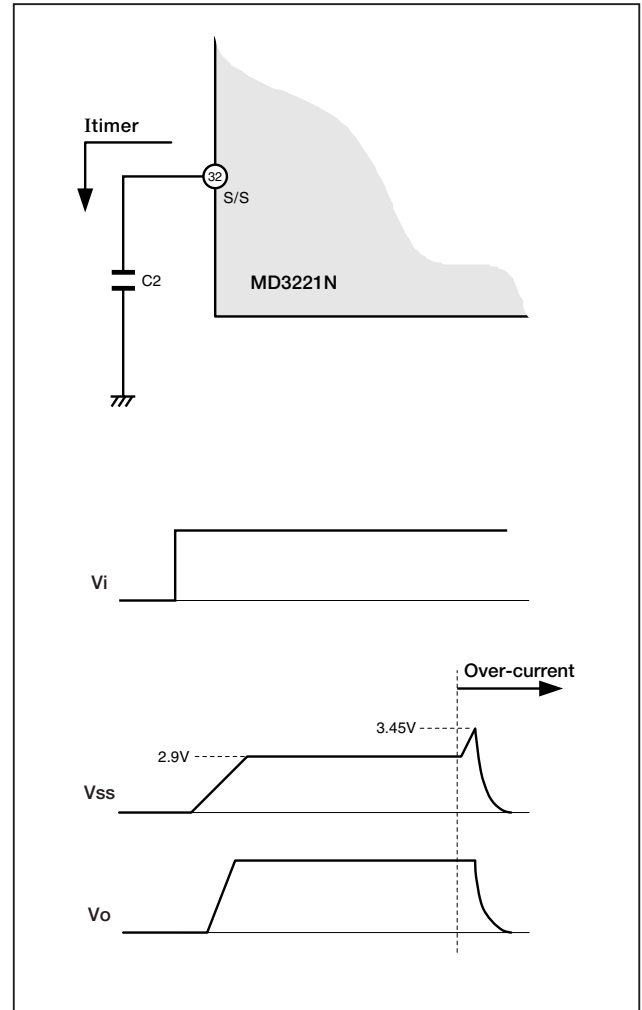

In the process of increasing the output voltage at start-up, the converter generally charges the output condenser resulting in the over-current condition. When the over-current protection circuit operates the latch is halted and start-up becomes impossible. The MD3221N timer circuit is locked to prevent its operation until the voltage at the S/S pin reaches 2.9V, and when the S/S pin is fully charged the lock is cleared and the timer circuit is ready for operation. If, however, the output voltage does not rise by the time the S/S pin is charged to 2.9V, the over-current protection circuit operates and the latch is halted. The output voltage must therefore reach the set voltage before the voltage at the S/S pin reaches 2.9V.

◆Short-circuit Protection

The short-circuit protection function described above operates when the output pin is completely short-circuited, or if power is switched on in the short-circuited condition, however as an extremely high current flows in the converter the latch circuit may not operate due to noise resulting from this short-circuit current. A protection circuit independent of the MD3221N should therefore be provided to accommodate such cases (refer to '20. External Protection Circuits').

◆The Current Limiting Function (external resistance detection)

In addition to over-current protection using the timer latch, the MD3221N incorporates a function to limit output current. Connection of an external resistor facilitates incorporation of droop characteristics for the output at any desired current value. Limiting the maximum output power simplifies start-up when the current supply capacity of the input power supply is low.

As shown in the diagram, the voltage drop across the inserted resistor (R2) is detected at 100mV.

The timer latch is disabled when droop characteristics are incorporated in the output using this function. When the impedance at the load side approaches zero, current increases and the timer latch operates to protect the circuit. The OCL+ and OCL- should be shorted if this function is not used.

● Circuit for Current Limiting Function (external resistance detection)

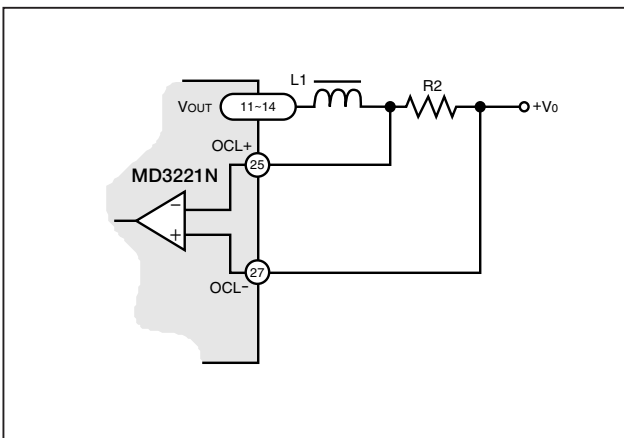

◆The Overheat Protection Function

The MD3221N incorporates an overheat protection function. The oscillator is halted when the junction temperature reaches 140°C due to operation under adverse conditions. The oscillator begins operation again when the temperature drops to 110°C. A reset signal is not required.

◆Error Amp Gain Adjustment

Error amp gain adjustment is effective in ensuring stable operation of the power supply circuit and good transient response. As the appropriate constant varies with the components used (eg output condenser), the MD3221N has an external error amp input/output pin for adjustment following selection of the primary components.

● Error Amp Gain Adjustment Circuit

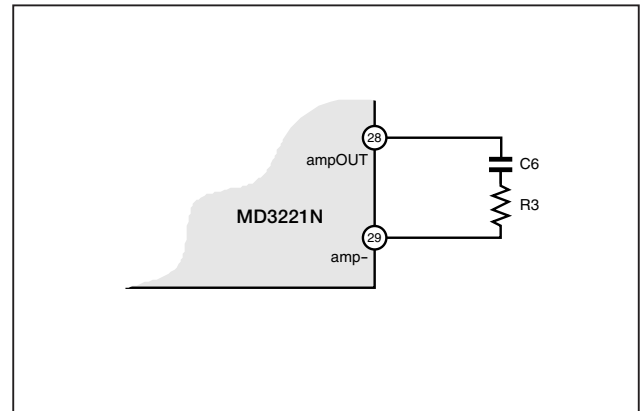

◆Bootstrap

The MD3221N employs an N-ch MOSFET in the high-side switch. The load supply circuit is bootstrapped to the gate of this MOSFET. A condenser (C3) is connected across the V_B and V_{OUT} pins as part of the power supply.

The capacitance of C3 must be sufficient in relation to the capacitance of the MOSFET gate. Use a ceramic condenser of approximately 0.1μF.

The load applied to C3 is supplemented from the Vboot pin via D1 with each pulse cycle. This is backed up by C4, while simultaneously stabilizing the voltage at the Vboot pin. The capacitance of C4 should therefore be equal to or greater than that of C3.

The voltage at the Vboot pin is controlled to 4V. As C3 is charged with a voltage which is less than this 4V by an amount equal to the V_F of the diode D1 when the V_F of this diode is high, the gate drive voltage drops and the previous performance is then not obtained. As the average current is in the order of a few mA, a small signal diode is sufficient, however it is important to avoid a diode with a high voltage resistance and high V_F . (refer to '17. Application Circuit Examples)

● Bootstrap Circuit

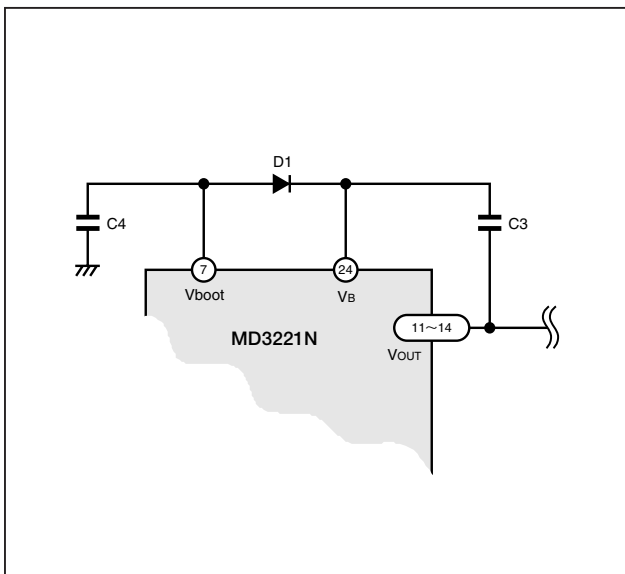

◆ The L Cut (cut off detect) Function

As previously described, a continuous current normally flows in the choke coil. This current includes a ripple current determined by the inductance and input/output voltage of the choke coil. As the average value is the output current, when the output current is less than $\Delta 1/2$ at low-load the current becomes discontinuous (cut-off).

The MD3221N allows selection of two operating modes in the cut-off region.

(1) Power Saving Mode (L cut ON)

This mode is ON when the LC and Vref pins are connected (H). When the choke coil current is cut-off the ON range is narrowed and the average current drops. As the current flowing in the MOSFET is reduced the losses at low-load are reduced, however variation in the ON range increases and transient response deteriorates in proportion. As power saving is beneficial at high input voltages, benefits at 5V are minimal and it is therefore recommended that (2) Current Regeneration Mode (L cut OFF) be used at low voltages.

● L1 Current Waveform at Low-load

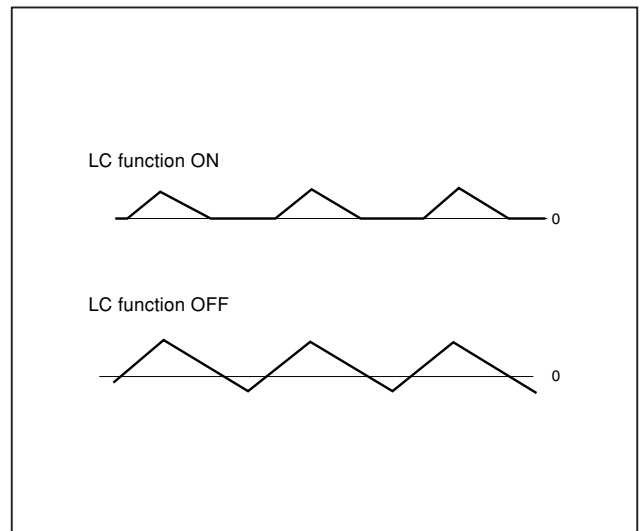

● Input Current ($V_i = 20V$) at Low-load

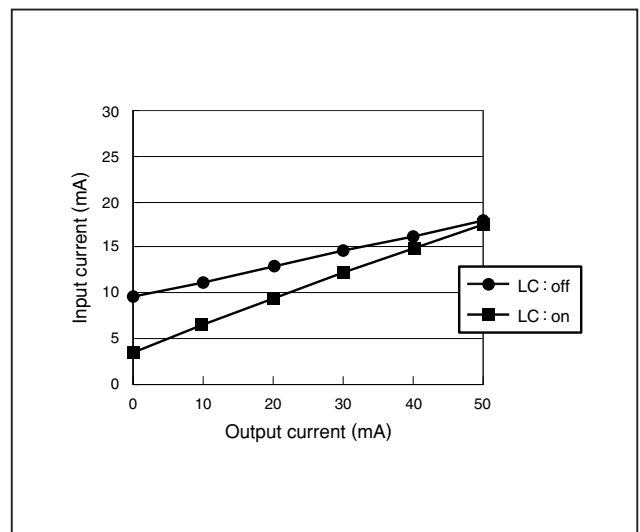

(2) Current Regeneration Mode (L cut OFF)

This mode is OFF when the LC and GND pins are connected (L). The current in the choke coil flows in the reverse direction, thus regenerating energy and resulting in a continuous current even at no-load.

As the ON range remains constant irrespective of the load applied, a stable response is obtained even under rapid changes in load from the no-load condition. On the other hand, as the actual current value increases, input current at low-load increases slightly in comparison with that at L cut ON.

● Transient Response with LC ON/OFF

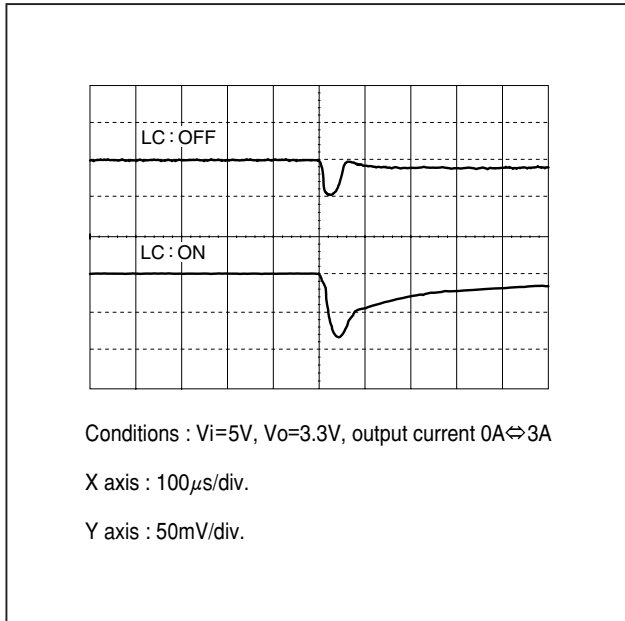

Transient response may be optimized with error amp gain adjustment (refer to 13 'Error Amp Gain Adjustment' for details). For the graph above, two $1200\mu F$ aluminum electrolytic capacitors (C5) were used for the output condenser, a $100pF$ condenser for C6, and a $1M\Omega$ resistor for R3.

Load current is extremely low, and the difference shown in the diagram is obtained at the transient response from the choke coil current cut-off region (up to approximately 15% of the maximum output current), however there is almost no difference in transient response due to LC ON/OFF in the non-cut-off region.

6 Cautions for Pattern Design

Substrate pattern design has a major effect on DC-DC converter characteristics. As the MD3221N switches a large current very rapidly, a large inductance component in the pattern will provide a source of noise. It is therefore very important to ensure that the primary circuit pattern is as thick and short as possible.

◆ Primary Circuit Pattern Design

● Wiring Pattern Illustration

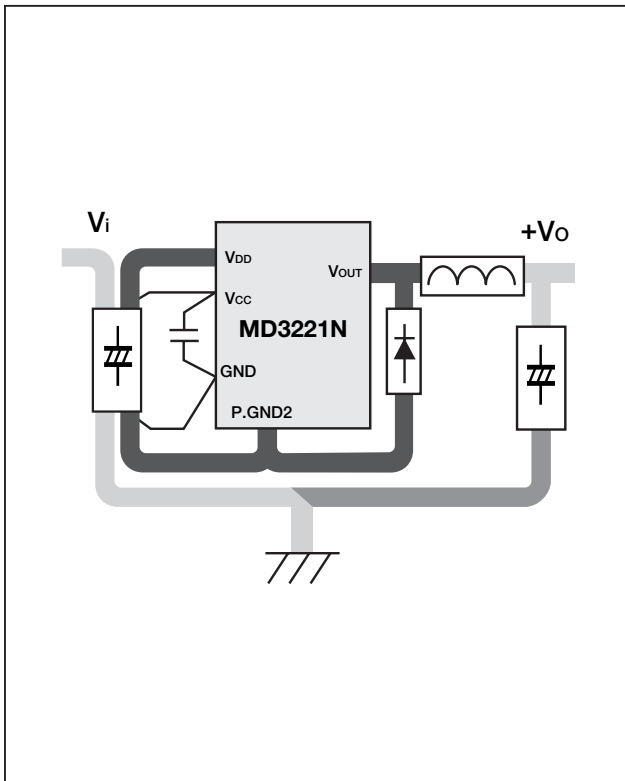

In the main circuit, the pattern between the input condenser and V_{DD} , and between $P.GND2$ and the input condenser, are subject to the greatest variations in current. Particular attention should therefore be given to ensure that these patterns are as thick and as short as possible. The use of through-holes in these patterns is to be avoided. Voltage drop due to the DC resistance of through-holes may result in a change in the over-current detection point in some cases.

The SBD pattern is connected next. Connect the anode to $P.GND2$, and the cathode to V_{OUT} . A long pattern in this case will not only result in considerable noise, but will also cause a drop in efficiency.

The choke coil and output condenser are connected next. As this pattern carries a continuous current, voltage drop rather than noise is the important consideration. A long pattern in this case will result in a voltage drop due to pattern DC resistance, and reduced efficiency.

The MD3221N is designed to radiate heat through the substrate pattern. In particular, both the V_{DD} and V_{OUT} pins are allocated each to four pins, and connected directly to the internal lead frame. All of these pins may therefore be used to ensure a large pattern area and thus provide for effective radiation of heat.

◆ Control Circuit Pattern Design

The control circuit pattern must be designed to ensure that it is not subject to noise, electric fields, and magnetic field from the choke coil.

The GND pin is the control IC GND. Connect this pin close to the input condenser. The V_{CC} pin is the control circuit input pin. Always connect a condenser (C7) across the V_{CC} and GND pins to eliminate noise.

The V_{ref} pin provides the reference voltage for the internal logic circuit of the IC. Noise at this pin may result in a malfunction. Always connect a condenser (C8) to this pattern to eliminate noise.

The $P.GND1$ pin is the low side driver GND and is connected to the $P.GND2$ pin. Ensure that these pins are connected close to the $-ve$ pin of the input condenser.

7 Application Circuit Examples

5V input, 2.5V output, 3A

300Hz operating frequency, R/C, LC : OFF

● Application Circuit Example

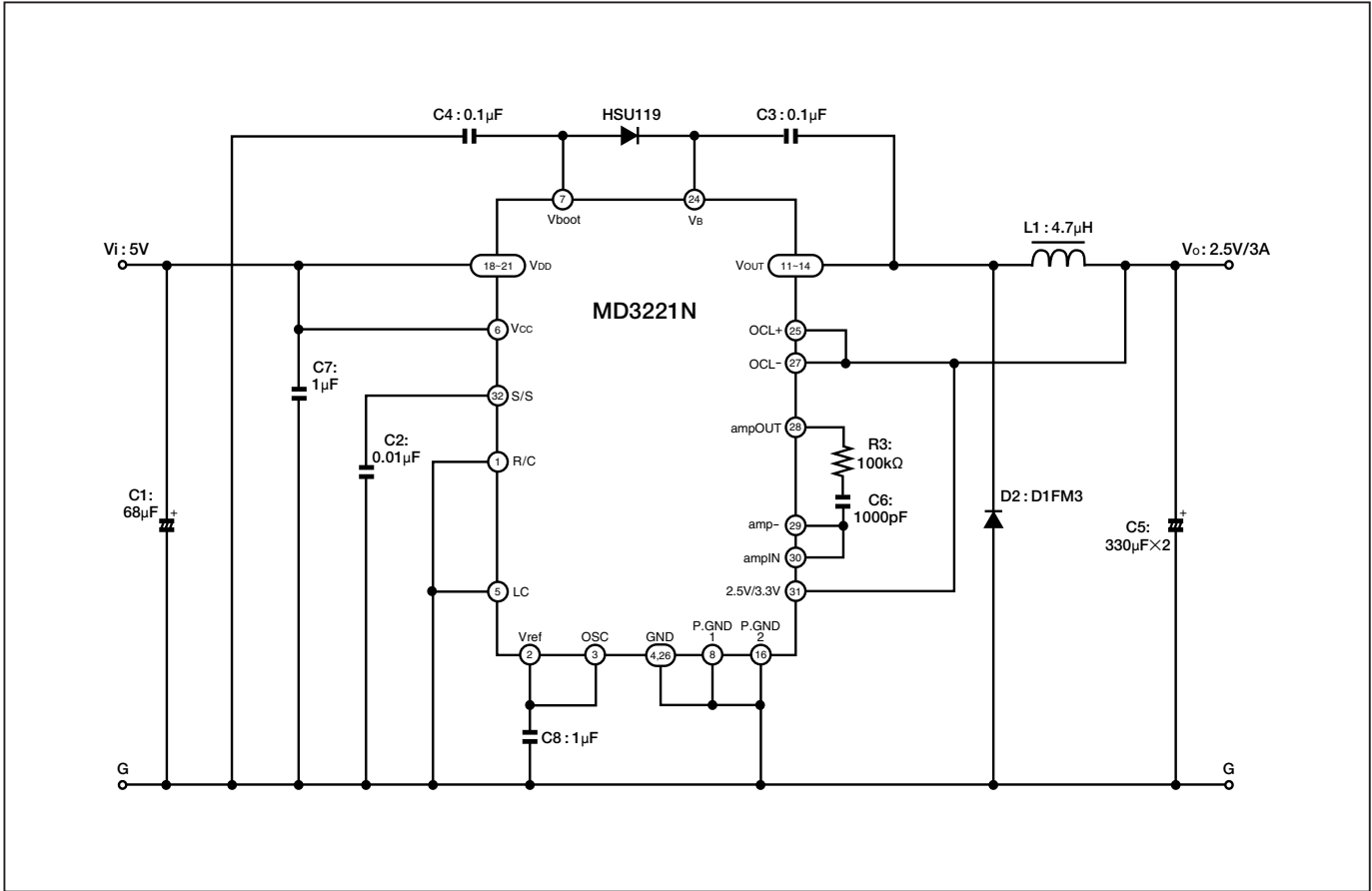

◆ Component Examples

Component code	Type	Rating
C1	High-polymer organic semiconductor electrolytic condenser	10V, 68 μ F, Irip.1.7A
C2	Ceramic condenser	25V, 0.01 μ F
C3	Ceramic condenser	25V, 0.1 μ F
C4	Ceramic condenser	25V, 0.1 μ F
C5	High-polymer organic semiconductor electrolytic condenser	6.3V, 330 μ F, ESR:40m Ω \times 2P
C6	Ceramic condenser	25V, 1000pF
C7	Ceramic condenser	10V, 1 μ F
C8	Ceramic condenser	10V, 1 μ F
D1	Switching diode	HSU119 [80V, 300mA, $V_F=1.2V_{(max)}$]
D2	Schottky barrier diode	D1FM3 [30V, 3A, $V_F=0.4V_{(max)}$]
L1	Inductor	4.7 μ H
R3	Resistor	100k Ω

8 Dimension Drawing

● Dimension Drawing (SSOP32)

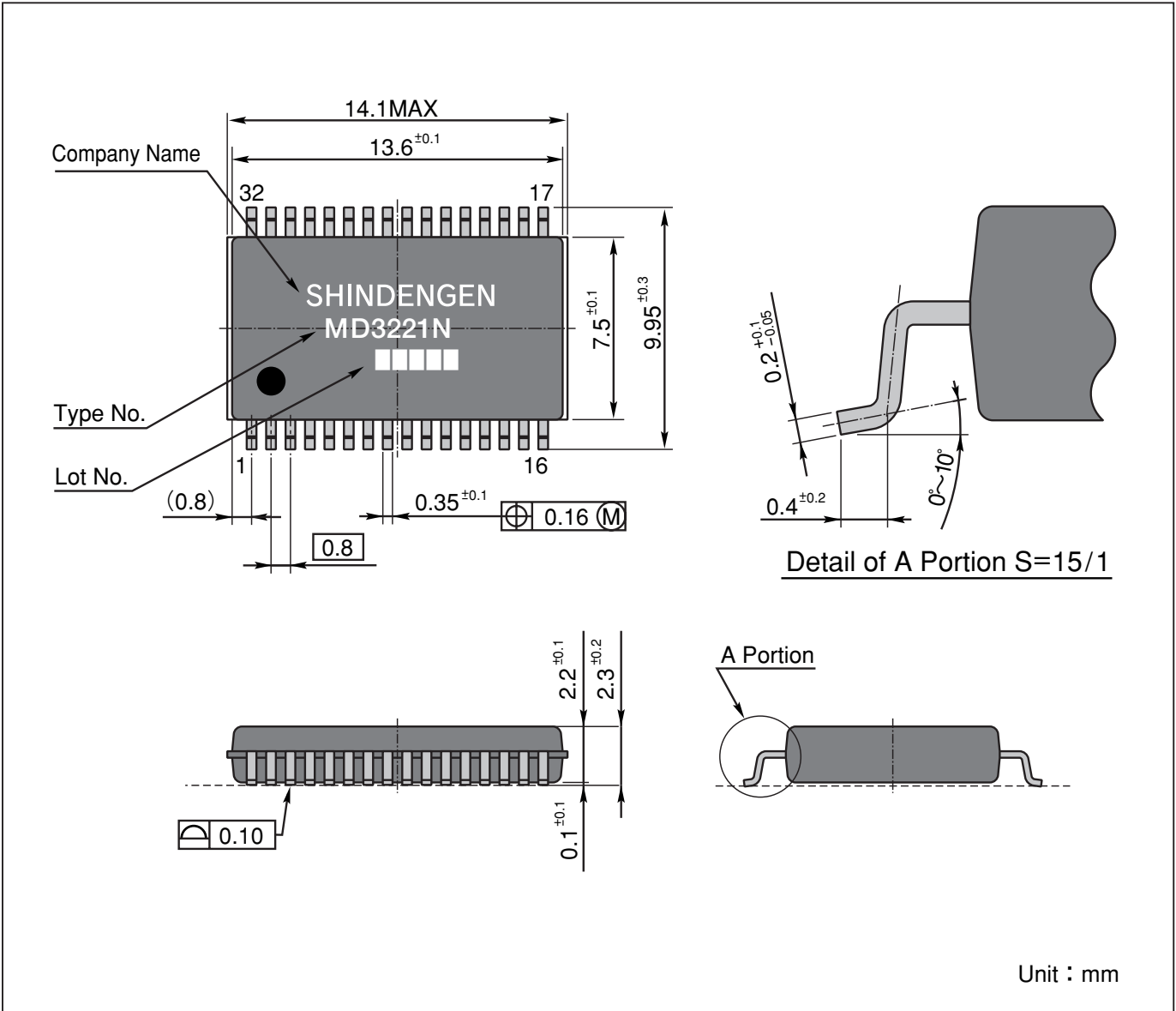

9 Mounting

◆ Substrate Mounting Example

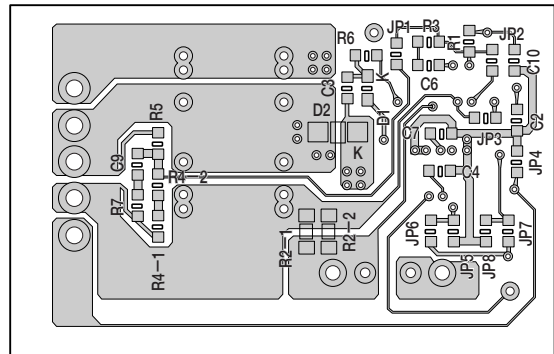
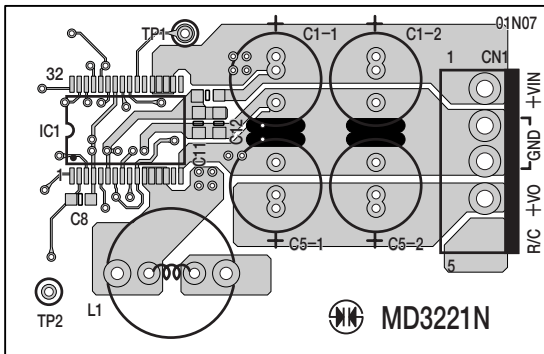

As this pattern does not incorporate an over-current protection circuit or input fuse they must be added separately if the circuit is to be used in practice.

◆ Cautions for Mounting

Both flow and reflow is applicable when mounting.

The recommended temperature profile for reflow soldering is shown below.

● Recommended Temperature Profile

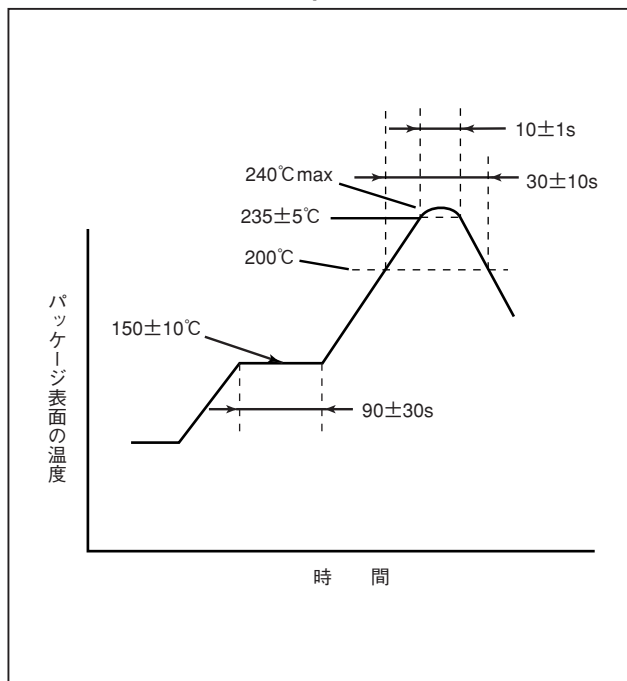

Ensure that the following requirements are met when using a soldering iron.

Tip temperature : 300°C maximum

Soldering time : 5 sec. maximum

● Soldering Pad Reference Pattern

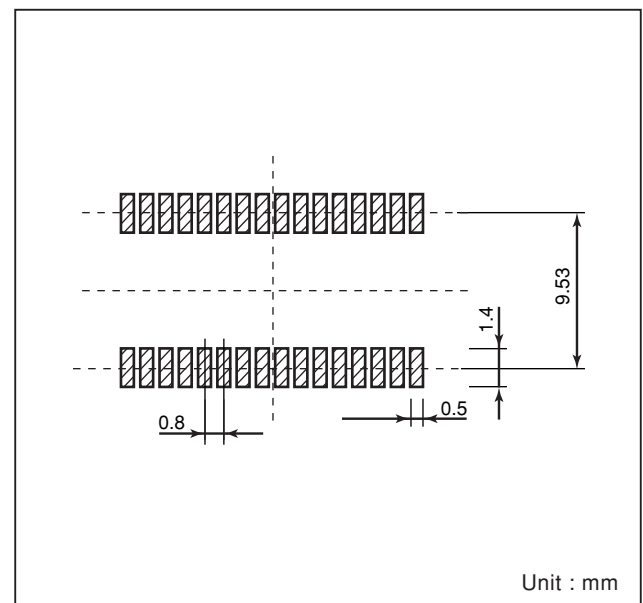

Unit : mm

10 External Protection Circuits

◆ Connection of Input Protection Devices

While the MD3221N incorporates both over-current protection and overheat protection functions, these protection circuits may not operate normally if a fault or a malfunction develops in the IC. A protective device (eg a fuse) should be inserted in the +ve input line to prevent overheating and consequent smoke or fire as a result of excess input current.

Select the rated current of the fuse etc in consideration of factors such as the DC-DC converter input current and current capacity of the input power supply.

◆ Connection of Over-voltage Protection Circuit

The MD3221N does not incorporate an over-voltage protection circuit. One of the modes supported is such that the input voltage will appear unchanged at the output despite operation being halted if the IC is damaged for any reason. Such damage to the load may result in smoke and fire, and an over-voltage protection circuit should therefore be added to prevent such problems.

A representative example of an over-voltage protection circuit is shown in the diagram below.

The over-voltage protection circuit is inserted on the load side of the output smoothing condenser.

● External Protection Circuits

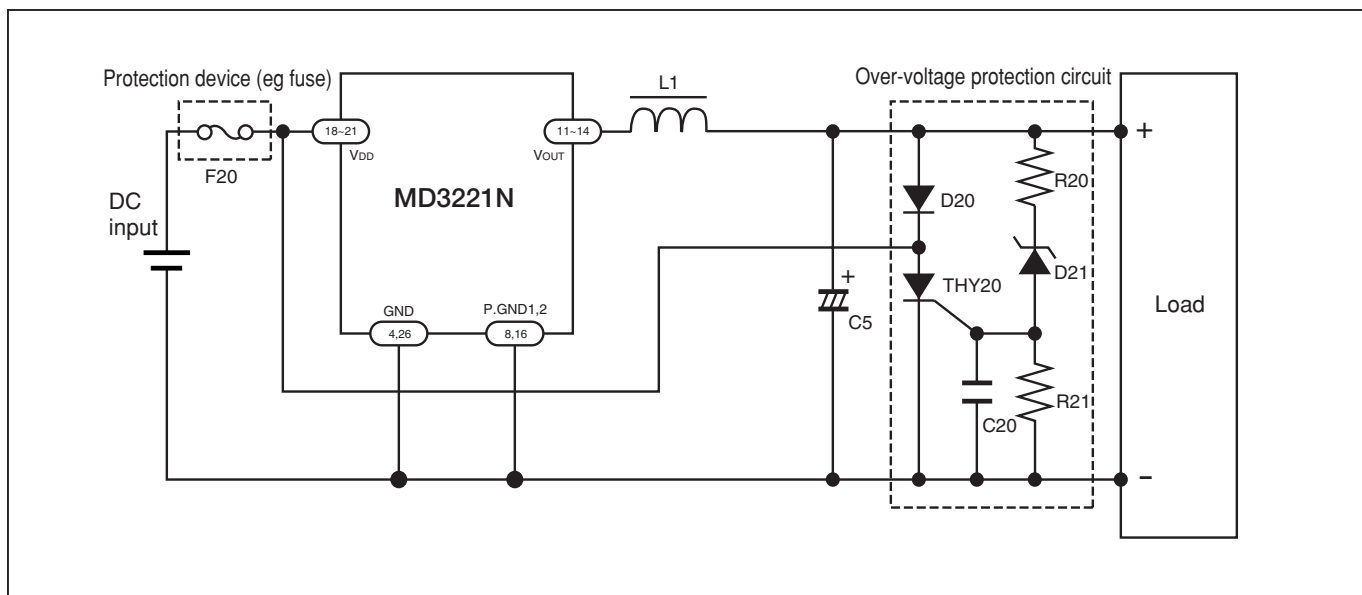

Component number	Component	Output voltage				
		2.5V	3.3V	5V	9V	12V
F20	Protection device (eg fuse)	Select in accordance with load current.				
R20	Resistor	0.1W 22Ω				
R21	Resistor	0.1W 100Ω				
C20	Ceramic condenser	0.33μF				
D20	Diode	M1FL20U 200V 1.1A				
D21	Zener diode	HZM2.7N B1	HZM3.6N B1	HZM5.6N B1	HZM11N B1	HZM15N B1
THY20	Thyristor	3P4J-Z 400V 3A				

11 Characteristics

◆ Output voltage : 3.3V

Conditions

LC : OFF, $f=300\text{kHz}$, $L=12\mu\text{H}$

$T_a=25^\circ\text{C}$ unless specified otherwise.

● Efficiency and Loss Characteristics ($f=300\text{kHz}$)

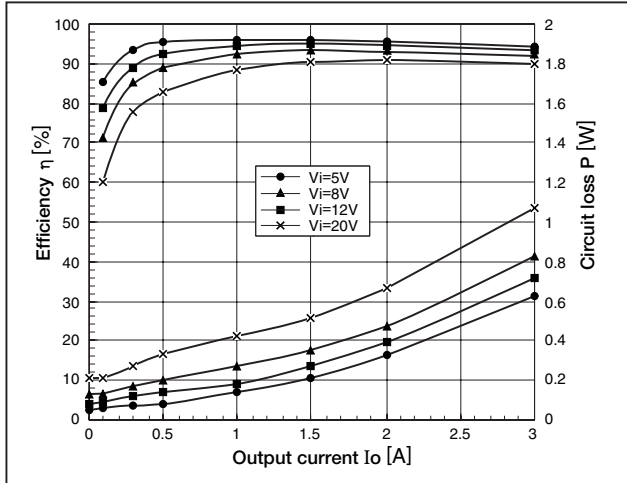

● Temperature Characteristics at $V_i=5\text{V}$, $I_o=3\text{A}$

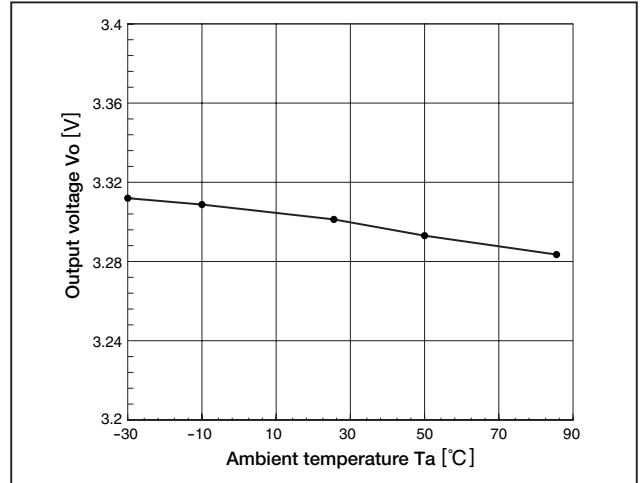

● Line Regulation at $I_o=3\text{A}$

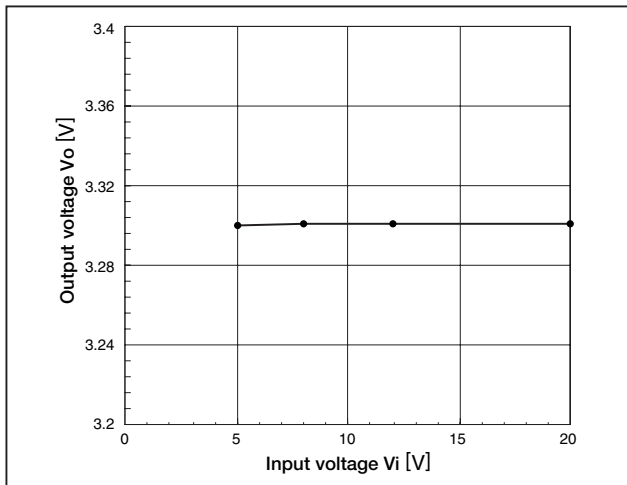

● Start-up Characteristics at $V_i=5\text{V}$, $I_o=3\text{A}$

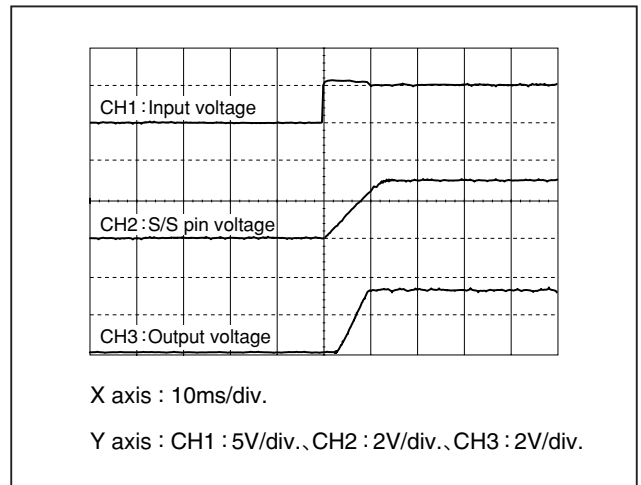

● Load Regulation at $V_i=5\text{V}$

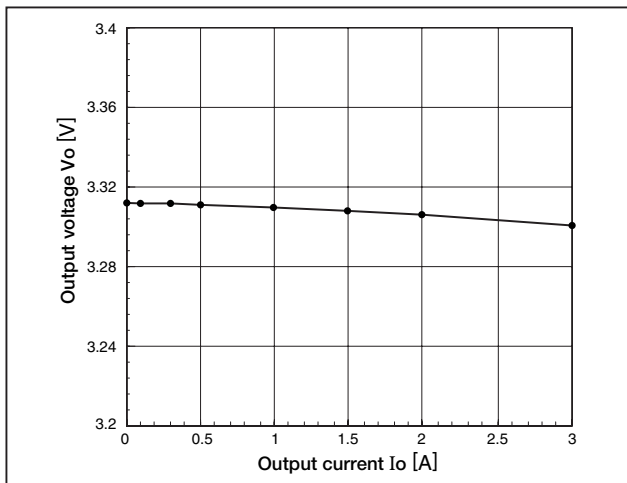

● R/C Start-up Characteristics at $V_i=5\text{V}$, $I_o=3\text{A}$

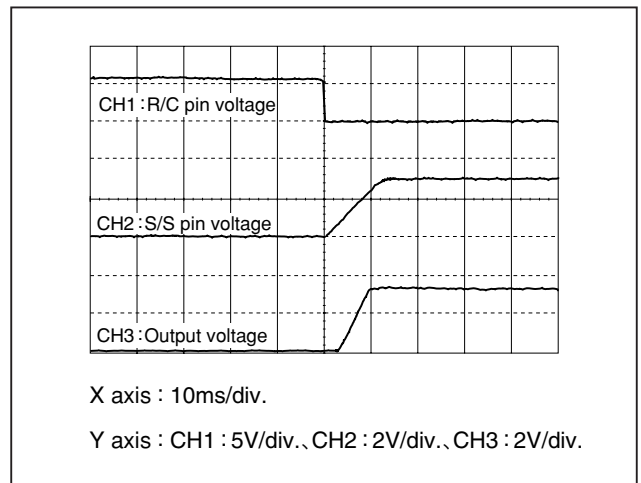

◆ Efficiency by Output Voltage

Conditions LC : OFF, $f=300\text{kHz}$, $L=12\mu\text{H}$

$T_a=25^\circ\text{C}$

Output voltage : $V_o=0.8\text{V}$, 1.2V , 1.8V , 2.5V , 3.3V

● Efficiency by Output Voltage at $V_i=5\text{V}$

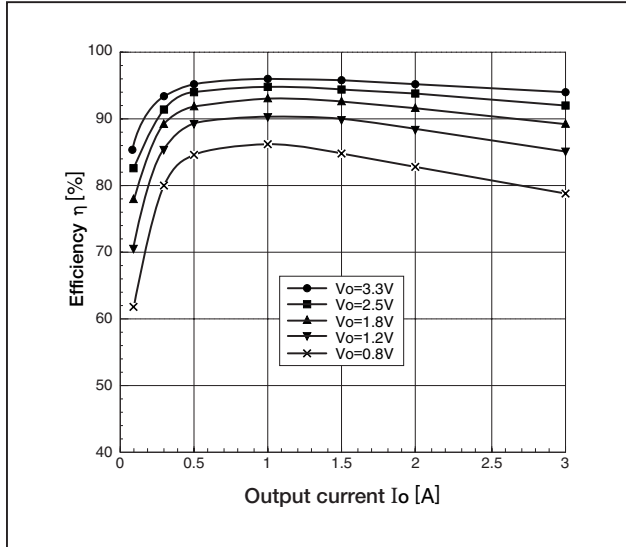

◆ Efficiency at Frequency of 100KHz

Conditions LC : OFF, $f=100\text{kHz}$, $L=22\mu\text{H}$

$T_a=25^\circ\text{C}$

Output voltage : 3.3V

● Efficiency and Losses ($f=100\text{kHz}$)

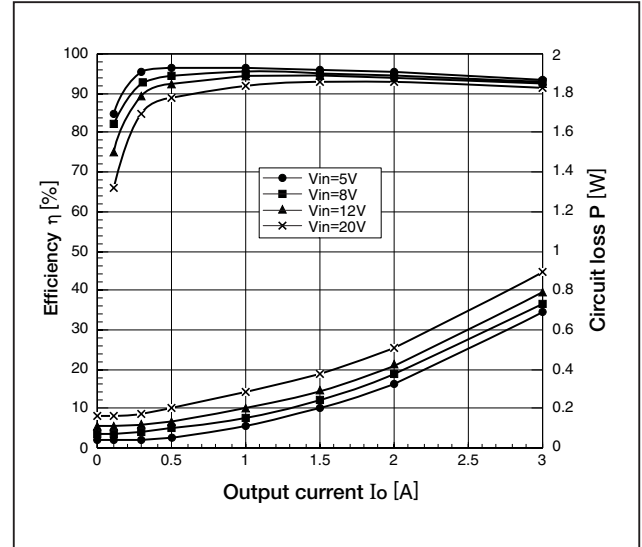

12 Packaging

◆ Tape & Reel

● Tape

Material : PVC+Carbon

Dimensions Comply with JIS, C-0806-3

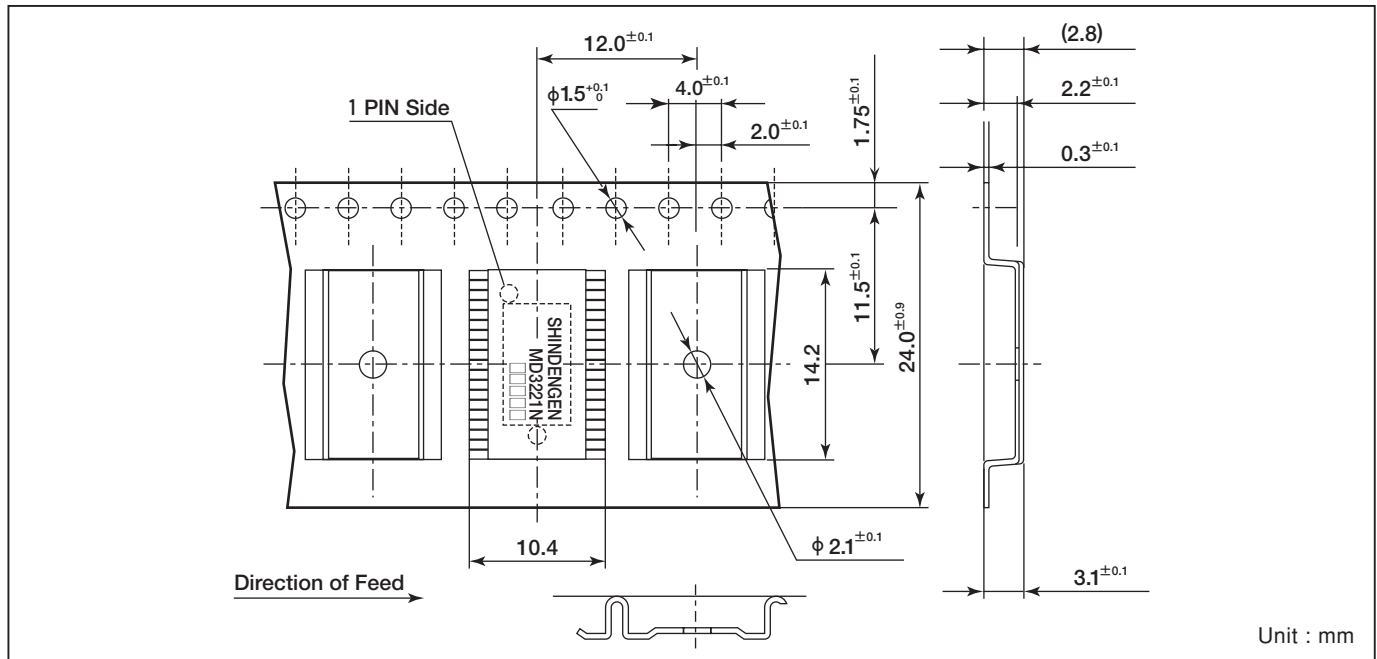

● Reel

Material : Polystyrene

Dimensions Comply with JEITA, ET-7200

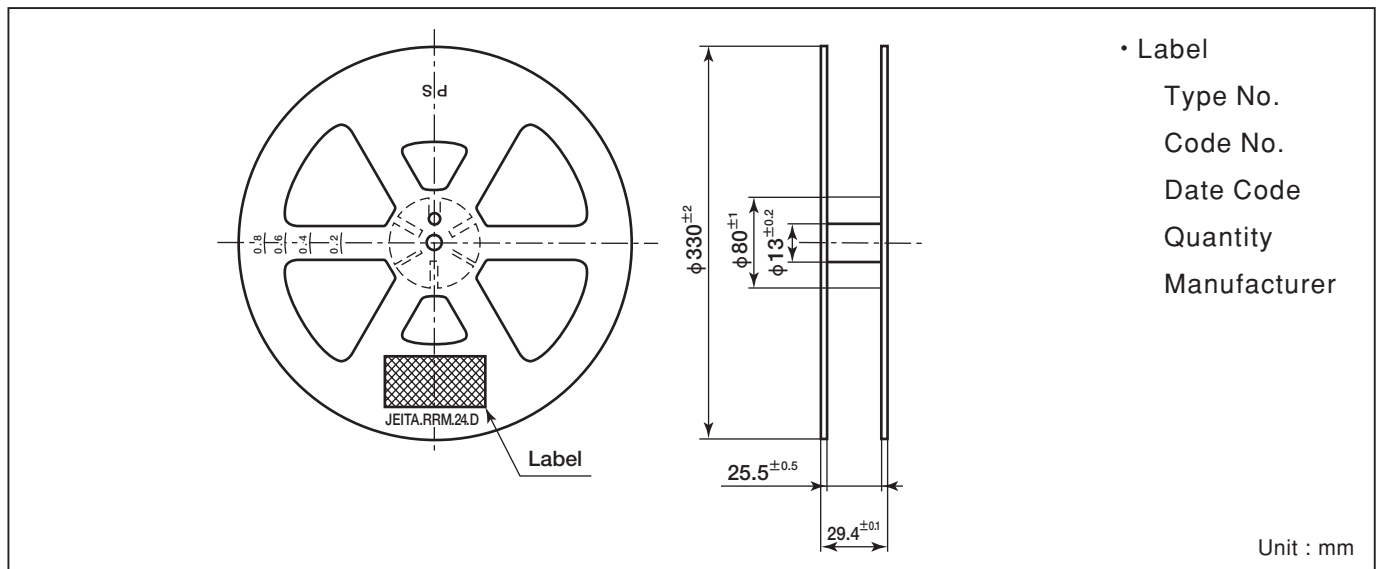

● Leader and Trailer

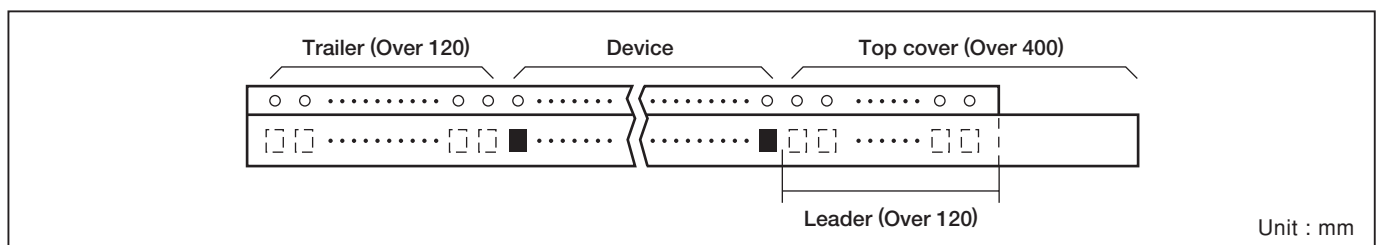

◆ Packing

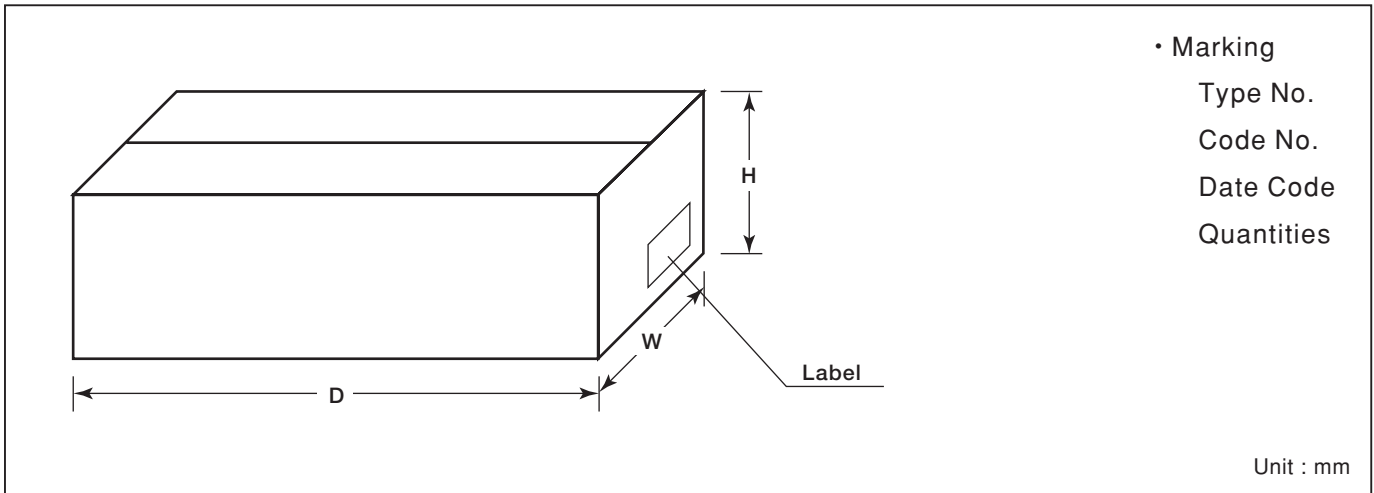

• Tape & Reel : 6,000pcs (3 Reels)/Outer Carton

◆ Ordering and Dimensions

Package	Code No.	Minimum Ordering Quantities	Quantities Per Inner Carton (pcs.)	Quantities per Outer Carton		Outer Carton (mm)		
				pcs./Carton	Weight (kg)	D	W	H
SSOP32	4072	2000	2000	6000	7.6	363	363	160

※ Please consolidate ordering quantities at basic ordering quantity unit.

U.S.A

Shindengen America, Inc.

Head Office

2985 E. Hillcrest Drive, Suite 140
Westlake Village, CA91362, U.S.A.
Phone:(1)-805-373-1130 Fax:(1)-805-373-3710

Chicago Office

411 Business Center Drive, Suite 112
Mt. Prospect, IL 60056 U.S.A.
Phone:(1)-847-827-7100 Fax:(1)-847-827-7122

Europe

Shindengen UK Ltd.

Howard Court, 12 Tewin Road,
Welwyn Garden City, Hertfordshire. AL7 1BW
Phone:(44)-1707-332-992 Fax:(44)-1707-332-955

German Branch Office

Kaiser-Strasse 25, D-40479 Dusseldorf, Germany
Phone:(49)-211-491968-0 Fax:(49)-211-4986499

Asia

Shindengen Singapore PTE Ltd.

159, Sin Ming Road #04-07, Amtech Building Singapore 575625
Phone:65-6552-3635 Fax:65-6552-4210

Shindengen (H.K.) Co., Ltd.

Head Office

Suite 3206, 32/F, Tower 1, The Gateway, 25 Canton Road, TST,
Kowloon, Hong Kong
Phone:(852)-2317-1884 Fax:(852)-2314-8561

Taipei Branch

Room N1010, 10F, Chia-Hsin Bldg. 2 No. 96, SEC. 2, Chung Shan N.
RD Taipei, Taiwan R.O.C.
Phone:886-2-2560-3990 Fax:886-2-2560-3991

Shanghai Liaison Office

W504, Sun Plaza, No.88 Xianxia Road Shanghai 200336, China
Phone:86-21-6270-1173 Fax:86-21-6270-0419

Shindengen Electric Mfg. Co., Ltd.

Seoul Office

Korea City Air-Terminal Bldg. 606, 159-6 Samsung-Dong
Kangnam-ku, Seoul, Korea
Phone:82(2)551-1431 Fax:82(2)551-1432

Taiwan Representative Office

Room N1010, 10F, Chia-Hsin Bldg.No.96,Sec.2 Chung Shan N. Road,
Taipei, Taiwan R.O.C.
Phone:886(2)2560-3990 Fax:886(2)2560-3991

Malaysia Regional Office

Suite A202, 2nd Floor, West Wing, Wisma Tractors No.7
Jalan SS 16/1, 47500 Subang Jaya, Selangor, Malaysia
Phone:60-3-5633-0834 Fax:60-3-5633-1179



SHINDENGEN ELECTRIC MFG. CO., LTD.

Ikebukuro office:
Ikebukuro, YS Bldg., 1-13-23, Minami-Ikebukuro, Toshima-
ku, Tokyo 171-0022, Japan
Phone : (81)-03-5951-8105, 8130
Fax : (81)-03-5951-8090

URL : http://www.shindengen.co.jp/top_e/index.html

This product is classified as the integrated circuit specified in Item 7 in the Attached Table No. 1 to the Export Trade Control Order and in Article 6 of the Ordinance of the Ministry of International Trade and Industry.

* This product is subject to the KNOW regulation.

May 2002