

Actron GmbH- Posthalterring 18 - 85599 Parsdorf service@actron.de

**Specification for Approval**

Customer : Actron GmbH Tel- 089-991509-0

Model Type : LCD Module

Model Number : PG12864ERS-INN-H

Edit : 0

Customer Sign	Sales Sign	Approved By	Prepared By

NO. PT-R-003-1

# CONTENTS

## 1.SPECIFICATIONS

- 1.1 Features
- 1.2 Mechanical Specifications
- 1.3 Absolute Maximum Ratings
- 1.4 DC Electrical Characteristics
- 1.5 Optical Characteristics
- 1.6 Backlight Characteristics

## 2.MODULE STRUCTURE

- 2.1 Counter Drawing
- 2.2 Interface Pin Description
- 2.3 Timing Characteristics
- 2.4 Display Command
- 2.5 Display Pattern

## 3.RELIABILITY

- 3.1 Content of Reliability Test

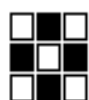

*POWERTIP TECHNOLOGY CORPORATION*

DISPLAY DEVICES FOR BETTER ELECTRONIC DESIGN

## 1. SPECIFICATIONS

### 1.1 Features

- Dot-matrix structure with 128 dots \*64 dots + 4 Icons
- 1/64 Duty, 1/6.2 bias
- STN LCD, positive
- Transflective LCD, gray
- 6 o'clock viewing angle
- 8 bits parallel data input
- EL Backlight

### 1.2 Mechanical Specifications

- Outline dimension : 54.0mm(L)\*50.0mm(W)\*7.5mm max.(H)
- Viewing area : 43.5mm \*29.0mm
- Active area : 40.92mm \*26.92mm
- Dot size : 0.28mm \* 0.35mm
- Dot pitch : 0.32mm \* 0.39mm

### 1.3 Absolute Maximum Ratings

Item	Symbol	Conditions	Min.	Max.	Unit
Power supply Voltage	VDD	-	0	6.7	V
LCD drive Supply voltage	VDD-VLC	-	0	17	V
Input voltage	VIN	-	-0.3	VDD	V
Operating temperature	TOPR	-	-20	50	°C
Storage temperature	TSTG	-	-30	70	°C
Humidity*1	HD	-	-	90	%RH

### 1.4 DC Electrical Characteristics

Item	Symbol	Condition	Min.	Typ.	Max.	Unit
Logic Supply voltage	VDD	-	2.8	5	5.5	V
“H” input voltage	VIH	-	0.7VDD	-	VDD	V
“L” input voltage	VIL	-	0	-	0.3VDD	V
LCD driving voltage	VLCD	VDD-VLC	-	8.5	-	V
Power Supply Current	IDD (EL OFF)	FLM=71 Hz VDD=5.0V	-	3.0	-	mA
	IDD (EL ON)	VDD-VO=8.5V BL+= 5.0 V (EL ON)		20		



### 1.5 Optical Characteristics

1/64 duty, 1/6.2 bias,  $V_{opr}=8.5V$ ,  $T_a=25^\circ C$

Item	Symbol	Conditions	Min.	Typ.	Max	Reference
Viewing angle	$\theta$	$C \geq 2.0, \varnothing = 0^\circ C$	$30^\circ$	-	-	Notes 1 & 2
Contrast	C	$\theta = 5^\circ, \varnothing = 0^\circ$	2	3	-	Note 3
Response time(rise)	ton	$\theta = 5^\circ, \varnothing = 0^\circ$	-	135ms	270ms	Note 4
Response time(fall)	toff	$\theta = 5^\circ, \varnothing = 0^\circ$	-	265ms	400ms	Note 4

Note 1: Definition of angles  $\theta$  and  $\varnothing$

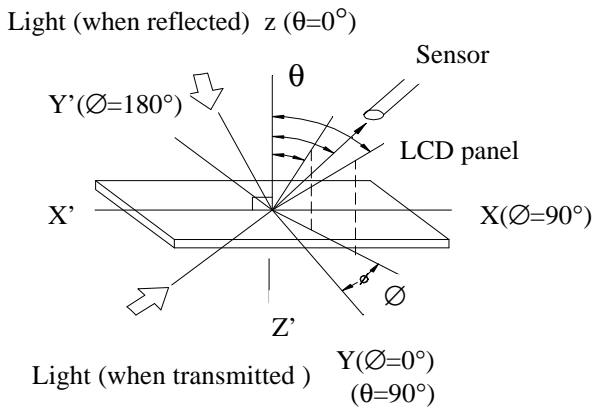

Note 2: Definition of viewing angles  $\theta_1$  and  $\theta_2$

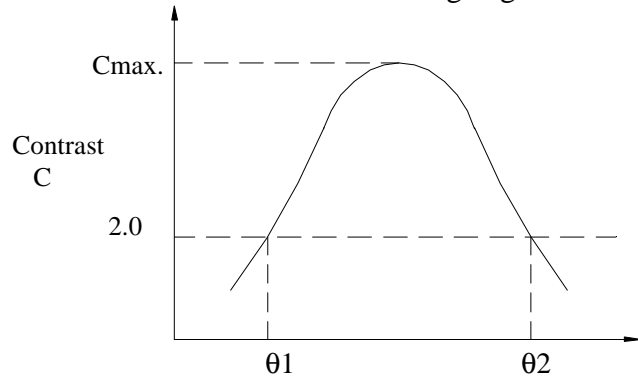

viewing angle  $\theta$  ( $\varnothing$  fixed)  
 Note : Optimum viewing angle with the naked eye and viewing angle  $\theta$  at  $C_{max}$ . Above are not always the same.

Note 3: Definition of contrast C

$$C = \frac{\text{Brightness (reflection) of unselected dot (B2)}}{\text{Brightness (reflection) of selected dot (B1)}}$$

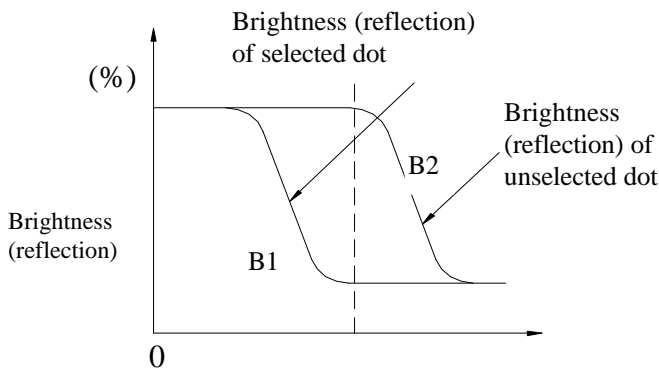

Note: Measured with a transmissive LCD operating voltage (v)

Note 4: Definition of response time

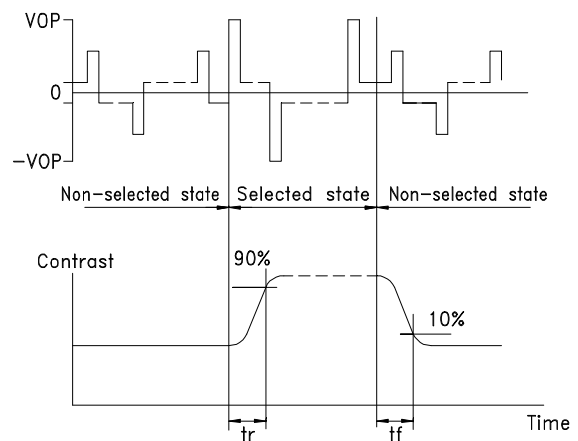

$V_{opr}$  : Operating voltage  
 $t_{on}$  : Response time (rise)       $f_{FRM}$  : Frame frequency  
 $t_{off}$  : Response time (fall)

## 1.6 Backlight Characteristic

The LCD Module is backlight using a EL backlight

- Maximum Ratings

Item	Symbol	Maximum	Unit
Supply voltage	Vmax	120	Vrms
Supply frequency	Fmax	1000	Hz
Operating humidity	Hopr	90	%RH.
Storage humidity	Hstg	70	%RH.

- Using specification

Item	Specification	Unit
Operating voltage	75~85	Vrms
Frequency	300~400	Hz

- Electrical characteristics

Item	Condition	Unit	Min	Typ	Max
Initiate intensity	(inverter)	Cd/m <sup>2</sup>	16	20	-
CIE color coordinate	VAC 75~85 Vrms		0.2901		
			0.3608		
Current density	Freq 300~400 HZ	mA/cm <sup>2</sup>	0.045		
Power density		mW/cm <sup>2</sup>	--		
Color	No.Sp4422		White		



## 2. MODULE STRUCTURE

### 2.1 Counter Drawing

\*See Appendix

### 2.2 Interface Pin Description

Pin No.	Symbol	Function
1	VSS	Power supply for logic GND
2	VDD	Power supply for logic (+2.8~5.5V)
3	VO	Operating voltage for LCD driving
4	D/ $\overline{I}$	Register selection input High =Data register Low =Instruction register (for write) Busy flag address counter (for read)
5	R/ $\overline{W}$	R/W signal input is used to select the read/write mode High =Read mode, Low =Write mode
6	E	Start enable signal to read or write the data
7~14	DB0~DB7	Data bus
15	CS1	Chip enable for D2 (segment 1 to segment 64)
16	CS2	Chip enable for D3 (segment 65 to segment 128)
17	$\overline{RST}$	Reset signal
18	VEE	Power supply for LCD driving
19	BL+	Enable (on/off) for EL B/L
20	BL-	No connection

Contrast Adjust

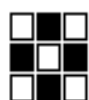
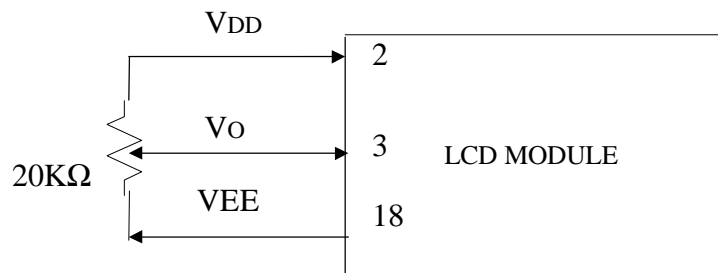

### 2.3 Timing Characteristics

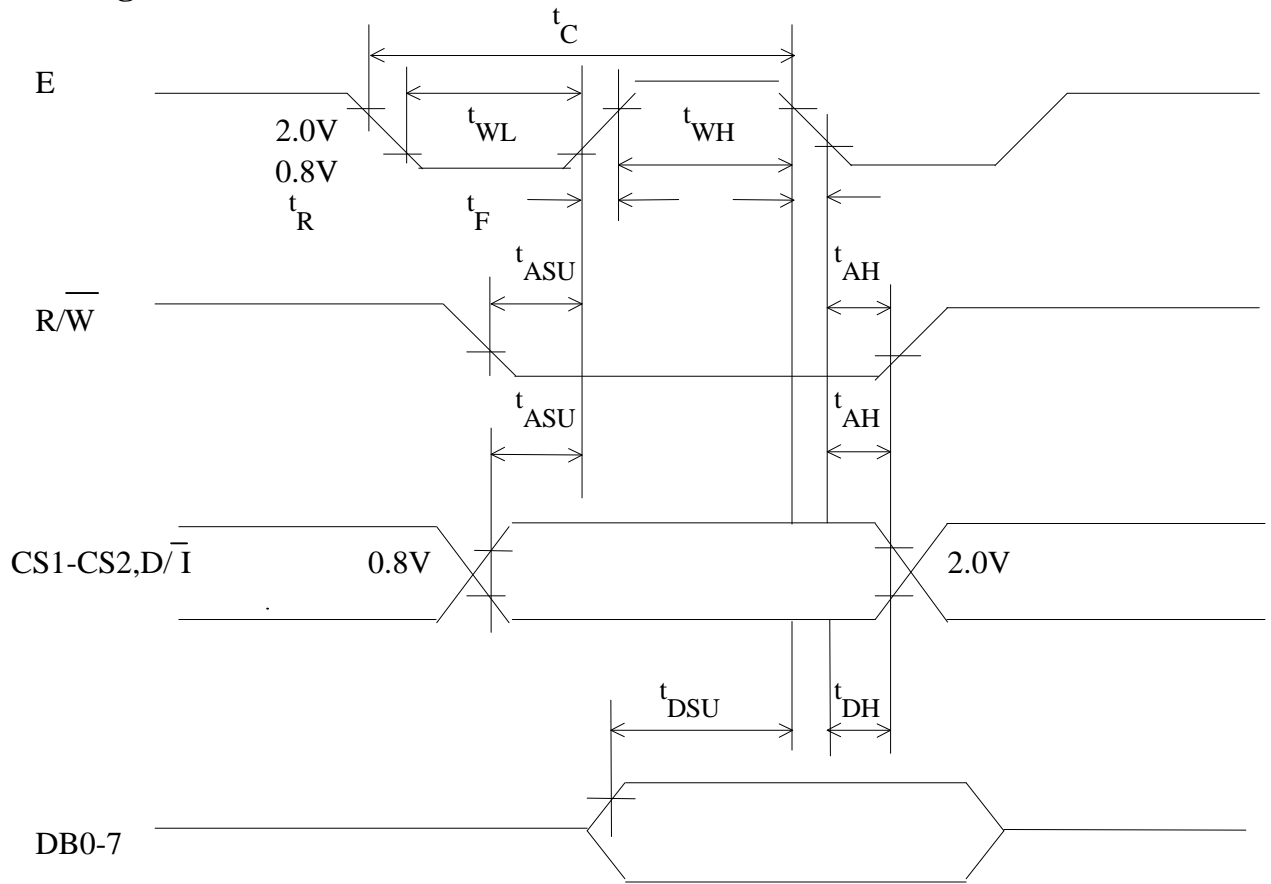

MPU Write timing

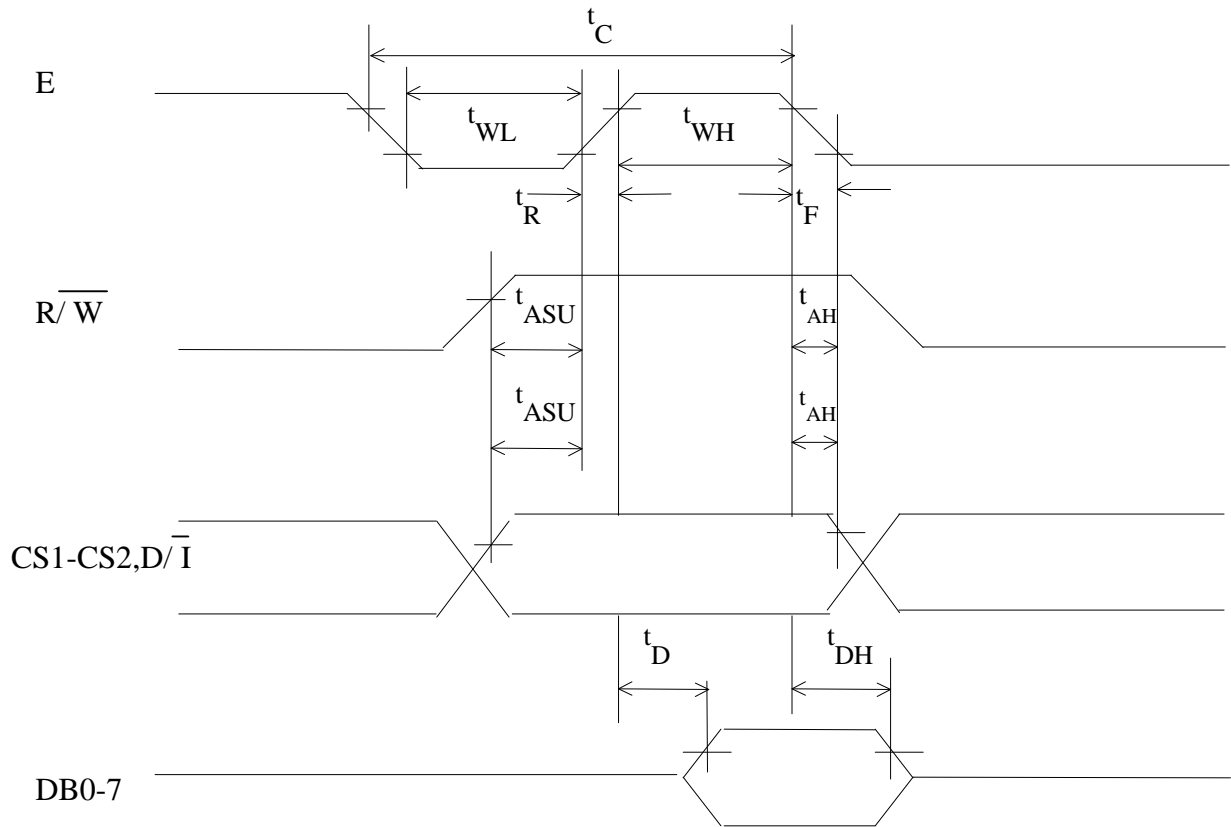

MPU Read timing



**POWERTIP TECHNOLOGY CORPORATION**

DISPLAY DEVICES FOR BETTER ELECTRONIC DESIGN

## AC Characteristics

(VDD=5V±10%, Ta=25 )

Characteristic	Symbol	Min.	Typ	Max	Unit
E Cycle	tC	1000	-	-	ns
E High Level Width	tWH	450	-	-	ns
E Low Level Width	tWL	450	-	-	ns
E Rise Time	tR	-	-	25	ns
E Fall Time	tF	-	-	25	ns
Address Set-Up time	tASU	140	-	-	ns
Address Hold Time	tAH	10	-	-	ns
Data Set-Up Time	tSU	200	-	-	ns
Data Delay Time	tD	-	-	320	ns
Data Hold Time (Write)	tDHW	10	-	-	ns
Data Hold Time (Read)	tDHR	20	-	-	ns

**POWERTIP TECHNOLOGY CORPORATION**

DISPLAY DEVICES FOR BETTER ELECTRONIC DESIGN



## 2.4 Display command

Instructions	Code										Functions	
	R/W	D/I	DB7	DB6	DB5	DB4	DB3	DB2	DB1	DB0		
Display on/off	0	0	0	0	1	1	1	1	1	1/0	Controls display on/off. RAM data and internal status are not affected. (0:OFF,1:ON)	
Display start line	0	0	1	1	Display start line (0-63)					Specifies the RAM line displayed at the top of the screen.		
Set Page (x address)	0	0	1	0	1	1	1	Page (0-7)			Sets the page (X address) of RAM at the page (X address) register.	
Set Y address	0	0	0	1	Y address (0-63)					Sets the Y address in the Y address counter.		
Status read	1	0	Busy	0	ON / OFF	Reset	0	0	0	0	Reads the status. Reset 1: Reset 0: Normal ON/OFF 1: Display off 0: Display on Busy 1: Internal operation 0: Ready	
Write display data	0	1	Write data								Writes data DB0 (LSB) to DB7 (MSB) on the data bus into display RAM.	Has access to the address of the display RAM specified in advance. After the access, Y address is increased by 1.
Read display data	1	1	Read data								Reads data DB0 (LSB) to DB7 (MSB) from the display RAM to the data bus.	

### Detailed Explanation

#### Display On/Off

R/W D/I DB7.....DB0

Code	0	0	0	0	1	1	1	1	1	D
	MSB				LSB					

The display data appears when D is 1 and disappears when D is 0. Though the data is not on the screen with D=0, it remains in the display data RAM. Therefore, you can make it appear by changing D=0 into D=1.



**POWERTIP TECHNOLOGY CORPORATION**

DISPLAY DEVICES FOR BETTER ELECTRONIC DESIGN

**Display Start Line**

R/W D/I	DB7.....							DB0		
Code	0	0	1	1	A	A	A	A	A	A
	MSB				LSB					

Z address AAAAAA (binary) of the display data RAM is set in the display start line register and displayed at the top of the screen. Figure 1 shows examples of display (1/64 duty cycle) when the start line=0-3. When the display duty cycle is 1/64 or more (ex. 1/32, 1/24 etc.), the data of total line number of LCD screen, from the line specified by display start line instruction, is displayed. See figure 1.

**Set page (X address)**

R/W D/I	DB7.....							DB0		
Code	0	0	1	0	1	1	1	A	A	A
	MSB				LSB					

X address AAA (binary) of the display data RAM is set in the X address register. After that, writing or reading to or from MPU is executed in this specified page until the next page is set. See figure 2.

**Set Y Address**

R/W D/I	DB7.....							DB0		
Code	0	0	0	1	A	A	A	A	A	A
	MSB				LSB					

Y address AAAAAA (binary) of the display data RAM is set in the Y address Counter. After that, Y address counter is increased by 1 every time the data is written or read to or from MPU.

**Status Read**

R/W D/I	DB7.....				....DB0					
Code	1	0	Busy	0	ON/OFF	Reset	0	0	0	0
	MSB				LSB					

- Busy

When busy is 1, the LSI is executing internal operations. No instructions are accepted while busy is 1, so you should make sure that busy is 0 before writing the next instruction.



**POWERTIP TECHNOLOGY CORPORATION**

DISPLAY DEVICES FOR BETTER ELECTRONIC DESIGN

- ON/OFF

Shows the liquid crystal display conditions: on condition or off condition.

When on/off is 1, the display is in off condition.

When on/off is 0, the display is in on condition.

- RESET

RESET=1 shows that the system is being initialized. In this condition, no instructions except status read can be accepted.

RESET=0 shows that initializing has finished and the system is in the usual operation condition.

### Write Display Data

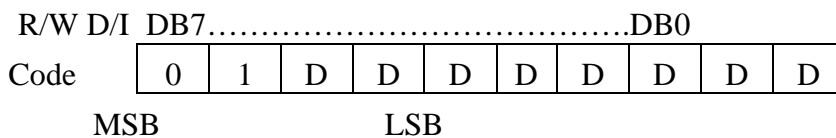

Write 8-bit data DDDDDDDD (binary) into the display data RAM. Then Y address is increased by 1 automatically.

### Read Display Data

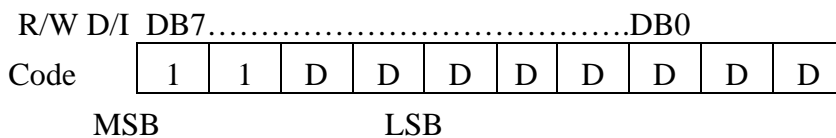

Reads out 8-bit data DDDDDDDD (binary) from the display data RAM. Then Y address is increased by 1 automatically.

One dummy read is necessary right after the address setting. For details, refer to the explanation of output register in “Function of Each Block”.



**POWERTIP TECHNOLOGY CORPORATION**

DISPLAY DEVICES FOR BETTER ELECTRONIC DESIGN

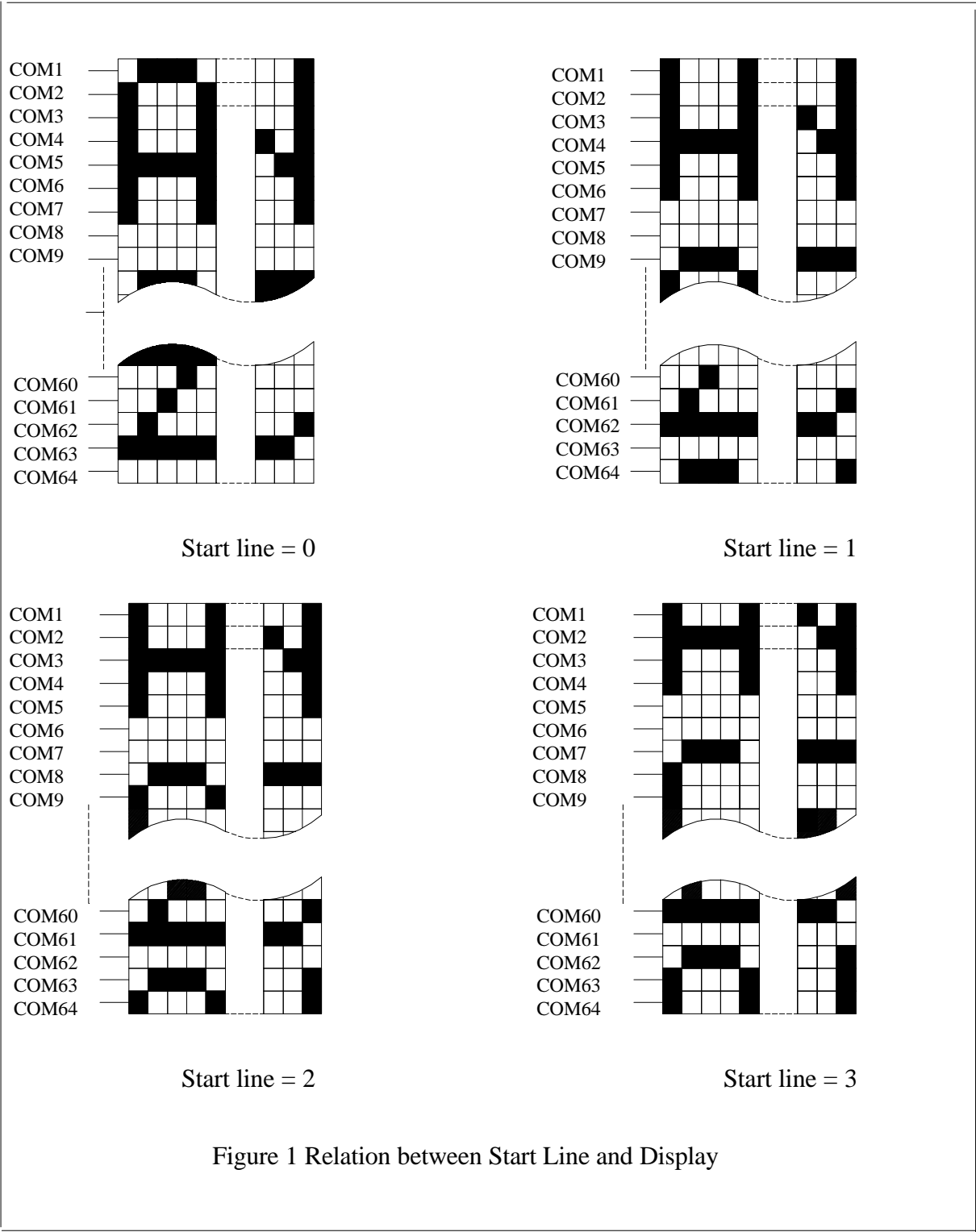

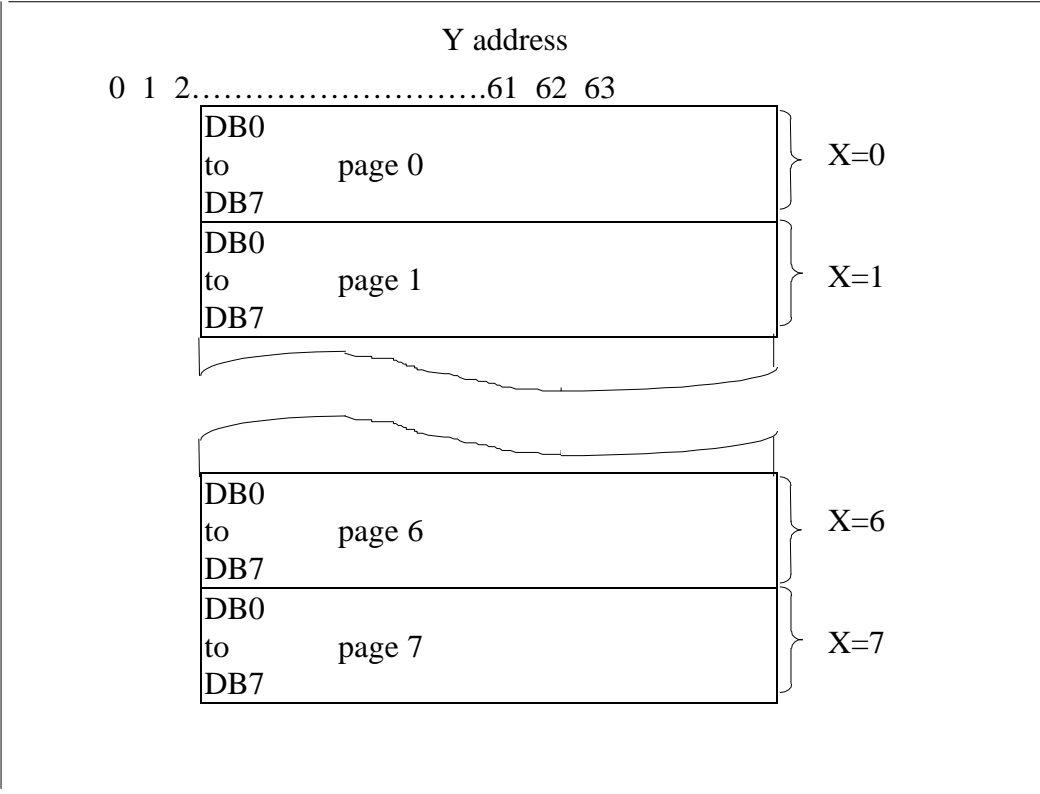
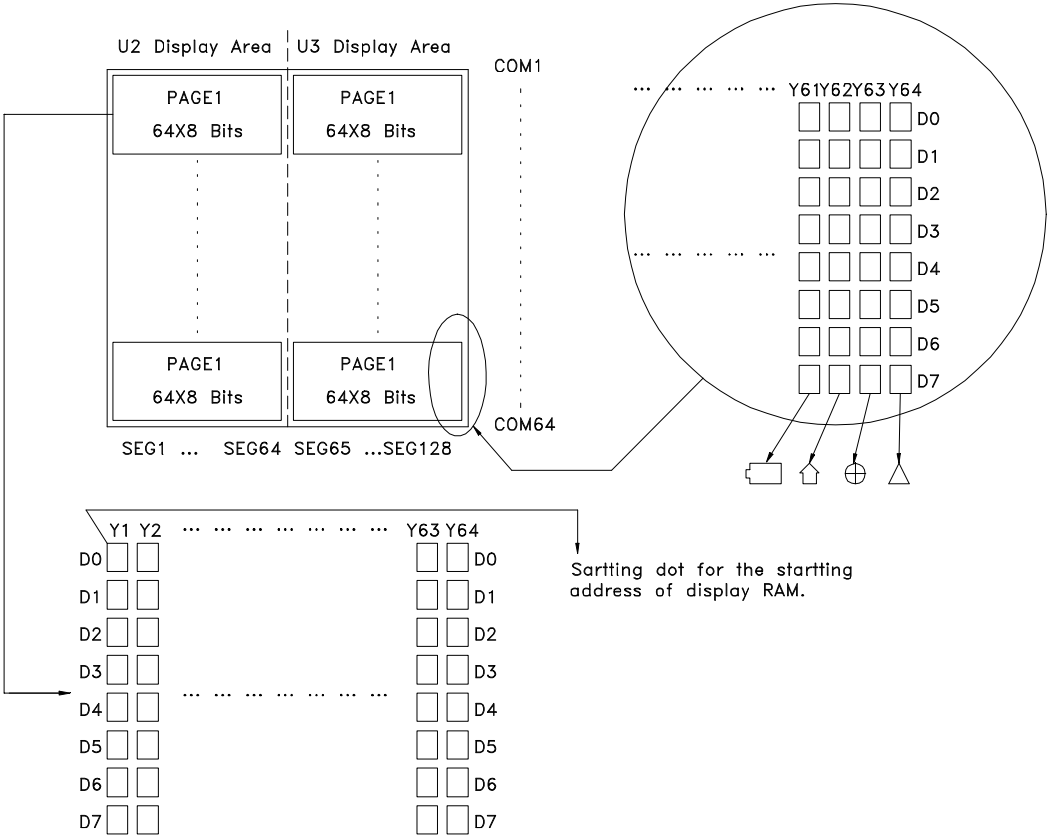
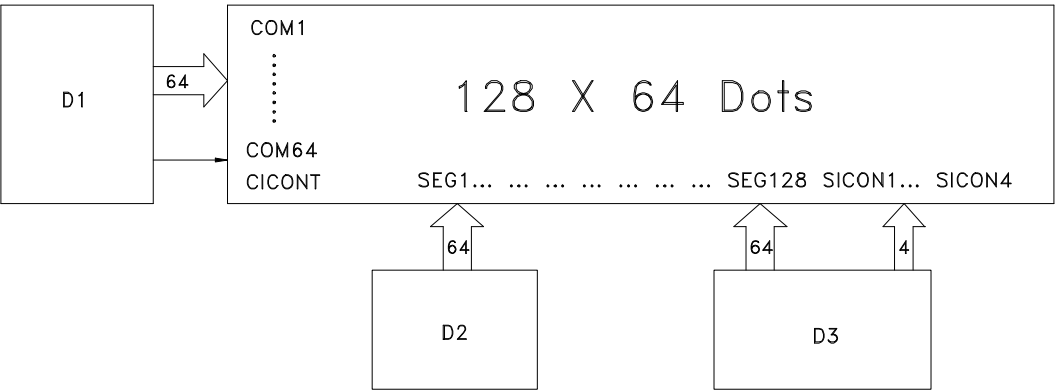

Figure 2 Address Configuration of Display Data RAM

2.5 Display Pattern



Each segment driver has 8 pages RAM, and each page has 64 X 8 bits RAM. D0~D7 are 8 bits transmitted data, write D0 is LSB and D7 is MSB.



### 3. RELIABILITY

#### 3.1 Content of Reliability Test

Environmental Test			
NO	Test Item	Content of Test	Test Condition
1	High temperature storage	Endurance test applying the high storage temperature for a long time.	70 100 hrs
2	Low temperature storage	Endurance test applying the high storage temperature for a long time.	-30 100 hrs
3	High temperature operation	Endurance test applying the electric stress (Voltage & Current) and the thermal stress to the element for a long time.	70 100 hrs
4	Low temperature operation	Endurance test applying the electric stress under low temperature for a long time.	-20 100 hrs
5	High temperature /Humidity Storage	Endurance test applying the high humidity storage for a long time.	70 ,90%RH 50 hrs
6	High temperature /Humidity Operation	Endurance test applying the electric stress (Voltage & Current) and temperature / humidity stress to the element for a long time.	70 ,90%RH 50 hrs
7	Temperature Cycle	Endurance test applying the low and high temperature cycle. -25    25    75 30min 5min 30min  ←—————→ 1 cycle	-25 / 75 10 cycle



**POWERTIP TECHNOLOGY CORPORATION**

DISPLAY DEVICES FOR BETTER ELECTRONIC DESIGN

