

TENTATIVE

TOSHIBA MOS DIGITAL INTEGRATED CIRCUIT SILICON GATE CMOS

16 MBIT (2 M × 8 BITS) CMOS NAND FLASH E²PROM

DESCRIPTION

The TC58V16 device is a single volt 16 Mbit NAND Electrically Erasable and Programmable Read Only Memory (NAND Flash EEPROM) with spare 64 K × 8 bits. The device is organized as 264 byte × 16 pages × 512 blocks. The device has a 264-byte, static register which allows the program and read data to be transferred between the register and the memory cell array in 264-byte increments. The Erase operation is implemented in a single block unit (4 Kbytes + 128 bytes; 264 bytes × 16 pages).

The TC58V16 is a serial type of memory device which utilizes the I/O pins for both address and data input/output as well as command inputs. The Erase and Program operations are automatically executed, making the device most suitable for applications such as solid state file storage, voice recording, image file memory for still cameras and other systems which require high-density, and non-volatile memory data storage.

FEATURES

- Organization
 - Memory cell array 264 × 8 K × 8
 - Register 264 × 8
 - Page size 264 byte
 - Block size (4 K + 128) bytes
- Mode
 - Read, Reset, Auto Page Program
 - Auto Block Erase, Suspend/Resume, Status Read
- Mode control
 - Serial input/output
 - Command control
- Power supply
 - V_{CC} = 3.0 V to 5.5 V
- Access time
 - Cell array-Register 25 μs max
 - Serial Read Cycle 80 ns min
- Operating current
 - Read (80 ns cycle) 15 mA typ
 - Program (ave.) 40 mA typ
 - Erase (ave.) 20 mA typ
 - Standby 100 μA
- Package
 - 400 mil TSOP Type II
 - TC58V16BFT : TSOP II 44/40 - P - 400 - 0.80B (Weight : 0.48 g typ)

PIN ASSIGNMENT (TOP VIEW)

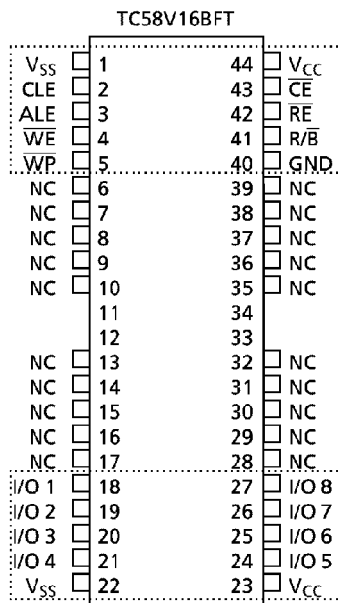

PIN NAMES

I/O 1 to 8	I/O Port
CE	Chip Enable
WE	Write Enable
RE	Read Enable
CLE	Command Latch Enable
ALE	Address Latch Enable
WP	Write Protect
R/B	Ready/Busy
GND	Ground Input
V _{CC} /V _{SS}	Power Supply/Ground (3.3 V/GND)

961001EBA1

● TOSHIBA is continually working to improve the quality and the reliability of its products. Nevertheless, semiconductor devices in general can malfunction or fail due to their inherent electrical sensitivity and vulnerability to physical stress. It is the responsibility of the buyer, when utilizing TOSHIBA products, to observe standards of safety, and to avoid situations in which a malfunction or failure of a TOSHIBA product could cause loss of human life, bodily injury or damage to property. In developing your designs, please ensure that TOSHIBA products are used within specified operating ranges as set forth in the most recent products specifications. Also, please keep in mind the precautions and conditions set forth in the TOSHIBA Semiconductor Reliability Handbook.

● The products described in this document are subject to foreign exchange and foreign trade control laws.

● The information contained herein is presented only as a guide for the applications of our products. No responsibility is assumed by TOSHIBA CORPORATION for any infringements of intellectual property or other rights of the third parties which may result from its use. No license is granted by implication or otherwise under any intellectual property or other rights of TOSHIBA CORPORATION or others.

● The information contained herein is subject to change without notice.

BLOCK DIAGRAM

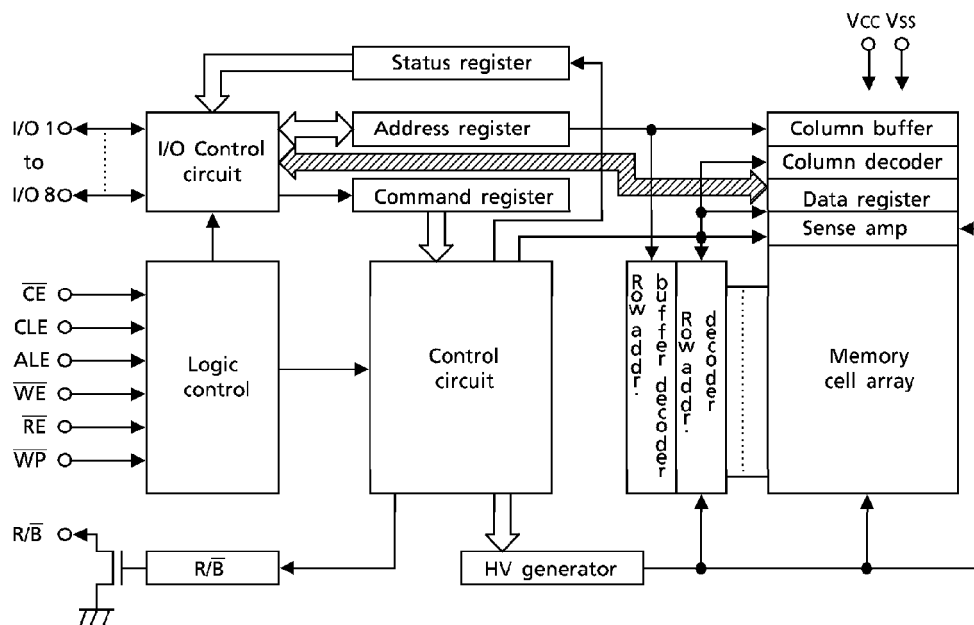

ABSOLUTE MAXIMUM RATINGS

SYMBOL	RATING	VALUE	UNIT
V _{CC}	Power Supply	- 0.6 to 7.0	V
V _{IN}	Input Voltage	- 0.6 to 7.0	V
V _{I/O}	Input/Output Voltage	- 0.6 V to V _{CC} + 0.5 V (≦ 5.5 V)	V
P _D	Power Dissipation	0.5	W
T _{SOLDER}	Soldering Temperature (10 s)	260	°C
T _{STG}	Storage Temperature	- 55 to 150	°C
T _{OPR}	Operating Temperature	0 to 70	°C

CAPACITANCE *(T_a = 25°C, f = 1 MHz)

SYMBOL	PARAMETER	CONDITION	MIN	TYP	MAX	UNIT
C _{IN}	Input	V _{IN} = 0 V	-	5	10	pF
C _{OUT}	Output	V _{OUT} = 0 V	-	5	10	pF

* This parameter is periodically sampled and is not tested for every component.

VALID BLOCK (1)

SYMBOL	PARAMETER	TC58V16			UNIT
		MIN	TYP	MAX	
N _{VB}	Valid Block Number	502	508	512	Blocks

(1) The TC58V16 occasionally contains unusable blocks. Refer to Application Note (17) toward the end of this document.

DC RECOMMENDED OPERATING CONDITIONS

SYMBOL	PARAMETER	MIN	MAX	UNIT
V _{CC}	Power Supply	3.0	5.5	V
V _{IH}	High Level Input Voltage	2.0 ^{*1} / 3.0 ^{*2}	V _{CC} + 0.5	V
V _{IL}	Low Level Input Voltage	-0.3 [*]	0.8	V

* - 2 V (pulse width ≤ 20 ns)

*1 V_{CC} = 3.3 V ± 0.3 V

*2 V_{CC} > 3.6 V

DC CHARACTERISTICS (Ta = 0° to 70°C, V_{CC} = 3.0 V to 5.5 V)

SYMBOL	PARAMETER	CONDITION	V _{CC} = 3.3 V ± 0.3 V			V _{CC} > 3.6 V			UNIT
			MIN	TYP	MAX	MIN	TYP	MAX	
I _{IL}	Input Leak Current	V _{IN} = 0V ~ V _{CC}	-	-	± 10	-	-	± 10	μA
I _{LO}	Output Leak Current	V _{OUT} = 0.4V ~ V _{CC}	-	-	± 10	-	-	± 10	μA
I _{CCO1}	Operating Current (Serial Read)	$\overline{CE} = V_{IL}$, I _{out} = 0mA, t _{cycle} = 80 ns	-	15	30	-	20	30	mA
I _{CCO2}	Operating Current (Command Input)	t _{cycle} = 80 ns	-	15	30	-	20	30	mA
I _{CCO3}	Operating Current (Data Input)	t _{cycle} = 80 ns	-	40	60	-	40	60	mA
I _{CCO4}	Operating Current (Address Input)	t _{cycle} = 80 ns	-	15	30	-	20	30	mA
I _{CCO5}	Programming Current	-	-	40	60	-	70	100	mA
I _{CCO6}	Erasing Current	-	-	20	40	-	25	45	mA
I _{CCS1}	Standby Current	$\overline{CE} = V_{IH}$	-	-	1	-	-	1	mA
I _{CCS2}	Standby Current	$\overline{CE} = V_{CC} - 0.2 V$	-	-	100	-	-	100	μA
V _{OH}	High Level Output Voltage	I _{OH} = -400 μA	2.4	-	-	2.4	-	-	V
V _{OL}	Low Level Output Voltage	I _{OL} = 2.1 mA	-	-	0.4	-	-	0.4	V
I _{OL} (R/ \overline{B})	Output Current of (R/ \overline{B}) Pin	V _{OL} = 0.4 V	-	8	-	-	8	-	mA

AC CHARACTERISTICS AND OPERATING CONDITIONS (Ta = 0° to 70°C, VCC = 3.0 V to 5.5 V) (1)

SYMBOL	PARAMETER	MIN	MAX	UNIT	NOTE
t _{CLS}	CLE Set-Up Time	20	–	ns	
t _{CLH}	CLE Hold Time	40	–	ns	
t _{CS}	\overline{CE} Set-Up Time	20	–	ns	
t _{CH}	\overline{CE} Hold Time	40	–	ns	
t _{WP}	Write Pulse Width	40	–	ns	
t _{ALS}	ALE Set-Up Time	20	–	ns	
t _{ALH}	ALE Hold Time	40	–	ns	
t _{DS}	Data Set-Up Time	30	–	ns	
t _{DH}	Data Hold Time	20	–	ns	
t _{WC}	Write Cycle Time	80	–	ns	
t _{WH}	\overline{WE} High Hold Time	20	–	ns	
t _{WW}	\overline{WP} High to \overline{WE} Falling Edge	100	–	ns	
t _{RR}	Ready to \overline{RE} Falling Edge	20	–	ns	
t _{RC}	Read Cycle Time	80	–	ns	
t _{REA}	\overline{RE} Access Time (Serial Data Access)	–	45	ns	
t _{CEH}	\overline{CE} High Time for the Last Address in Serial Read Cycle	250	–	ns	(3)
t _{REAID}	\overline{RE} Access Time (ID Read)	–	45	ns	
t _{RHZ}	\overline{RE} High to Output High Impedance	–	30	ns	
t _{CHZ}	\overline{CE} High to Output High Impedance	–	20	ns	
t _{REH}	\overline{RE} High Hold Time	20	–	ns	
t _{IR}	Output High Impedance to \overline{RE} Rising Edge (Status Read)	0	–	ns	
t _{RSTO}	RE Access Time (Status Read)	–	45	ns	
t _{CSTO}	\overline{CE} Access Time (Status Read)	–	55	ns	
t _{RHW}	\overline{RE} High to \overline{WE} Low	0	–	ns	
t _{WHC}	\overline{WE} High to \overline{CE} Low (Status Read)	50	–	ns	
t _{WHR}	\overline{WE} High to \overline{RE} Low (Status Read)	50	–	ns	
t _{AR1}	ALE Low to \overline{RE} Low (ID Read)	200	–	ns	
t _{CR}	\overline{CE} Low to \overline{RE} Low (ID Read)	200	–	ns	
t _R	Memory Cell Array to Starting Address	–	25	μs	
t _{WB}	WE High to Busy	–	200	ns	
t _{AR2}	ALE Low to \overline{RE} Low (Read Cycle)	150	–	ns	
t _{RB}	\overline{RE} Last Clock Rising Edge to Busy (in Sequential Read)	–	200	ns	
t _{CRY}	\overline{CE} High to Ready (in Case of Interception by \overline{CE} in Read Mode)	–	600 + tr(R/B)	ns	(2)
t _{RST}	Device Reset Time (Read/Program/Erase/after Suspend)	–	10/20/500/10	μs	

AC TEST CONDITIONS

- Input level : 2.4 V / 0.4 V (Vcc = 3.3 V ± 0.3 V)
3.4 V / 0.4 V (Vcc > 3.6 V)
- Input comparison level : 1.5 V / 1.5 V
- Output data comparison level : 1.5 V / 1.5 V
- Output load : 1 TTL & CL (100 pF)

- (1) Transition time (t_T) = 5 ns
- (2) The \overline{CE} High to Ready time depends on the pull-up resistor tied to the R/\overline{B} pin. (Refer to Application Note (10) toward the end of this document.)
- (3) If the delay between \overline{RE} and \overline{CE} is less than 200 ns and t_{CEH} is greater than or equal to 250 ns, reading will stop.
If the \overline{RE} -to- \overline{CE} delay is less than 30 ns, the device will not return to the Busy state.

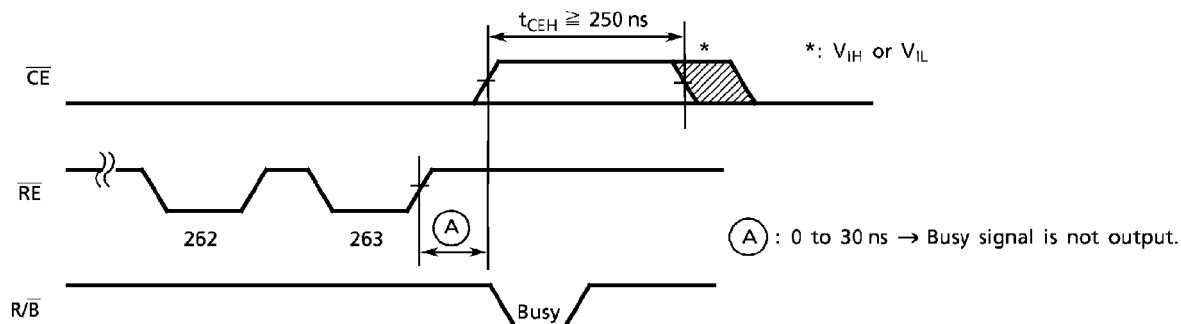

PROGRAMMING AND ERASING CHARACTERISTICS ($T_a = 0^\circ$ to 70°C , $V_{CC} = 3.0$ V to 5.5 V)

SYMBOL	PARAMETER	MIN	TYP	MAX	UNIT	NOTE
t_{PROG}	Average Programming Time		300 to 500	3000	μs	
N	Number of Programming Cycles on Same Page			10		(1)
t_{BERASE}	Block Erasing Time	6	6	100	ms	
t_{SR}	Suspend Input to Ready			500	μs	
$N_{W/E}$	Number of Write/Erase Cycles			1×10^6	cycles	(2)

- (1) Refer to Application Note (15) toward the end of this document.
- (2) Refer to Application Note (18) toward the end of this document.

TIMING DIAGRAMS

Latch Timing Diagram for Command/Address/Data

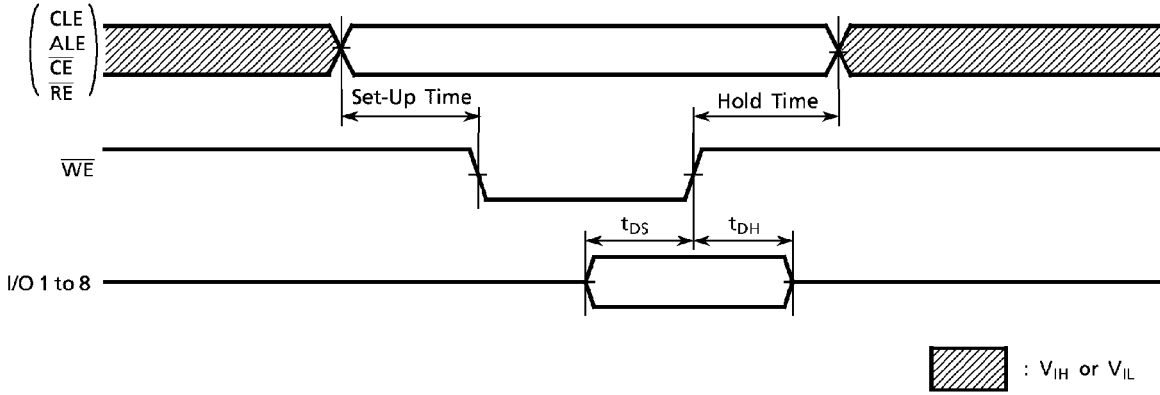

Command Input Cycle Timing Diagram

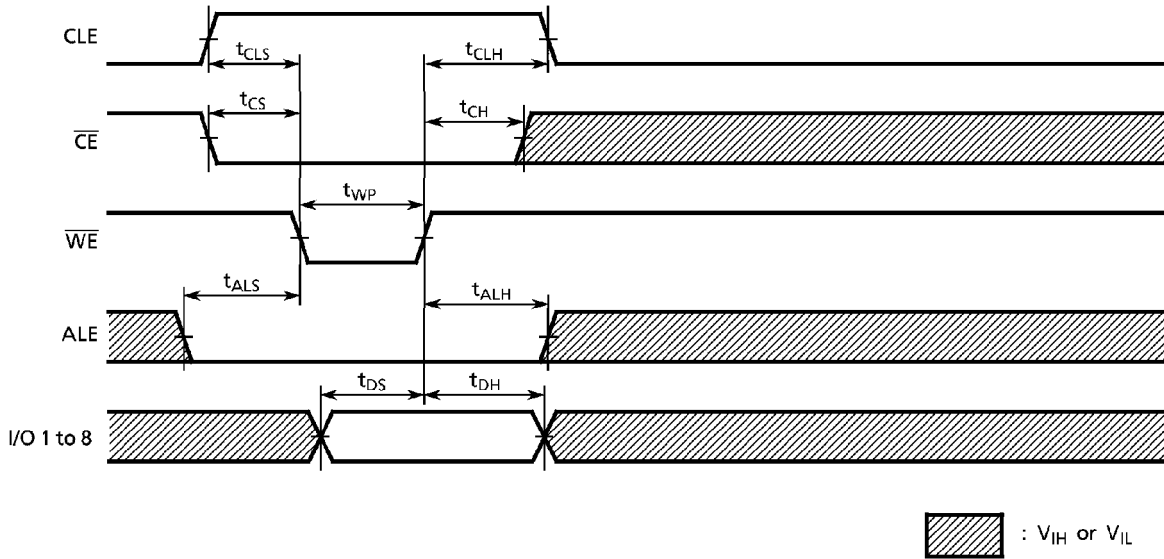

Address Input Cycle Timing Diagram

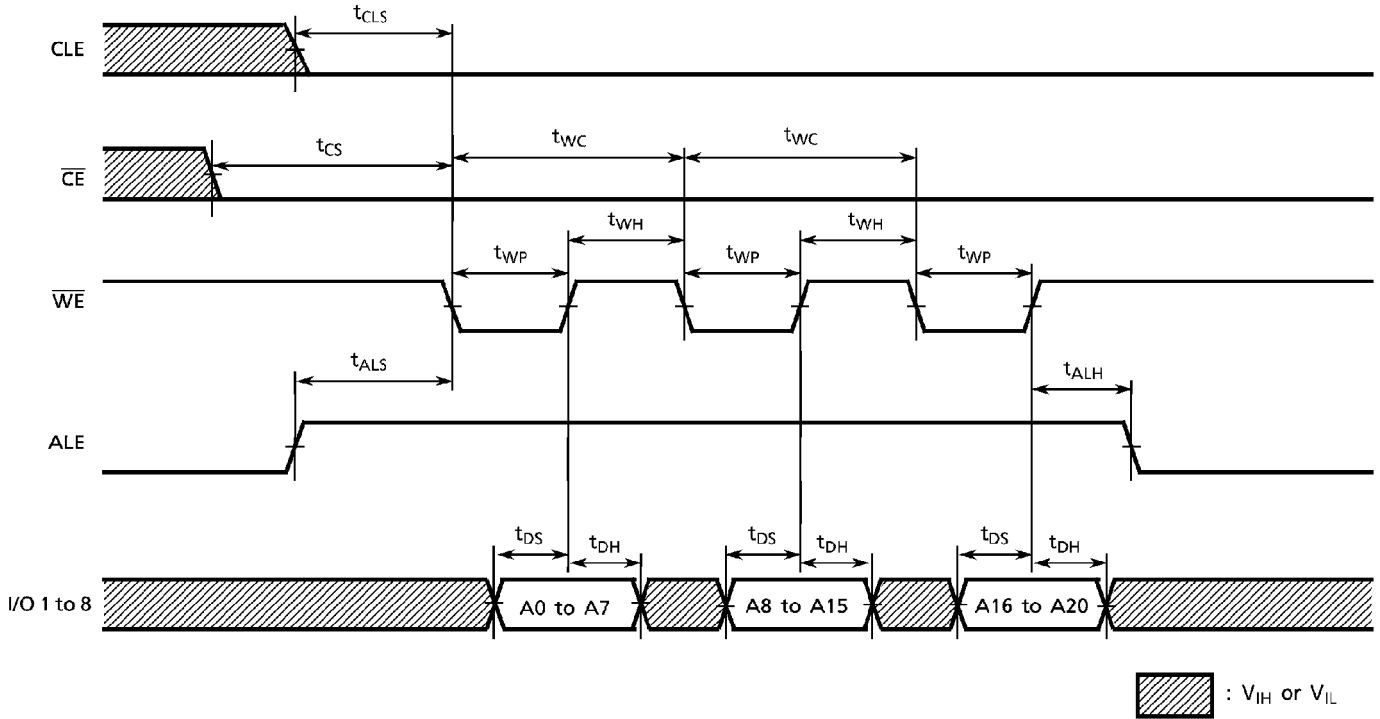

Data Input Cycle Timing Diagram

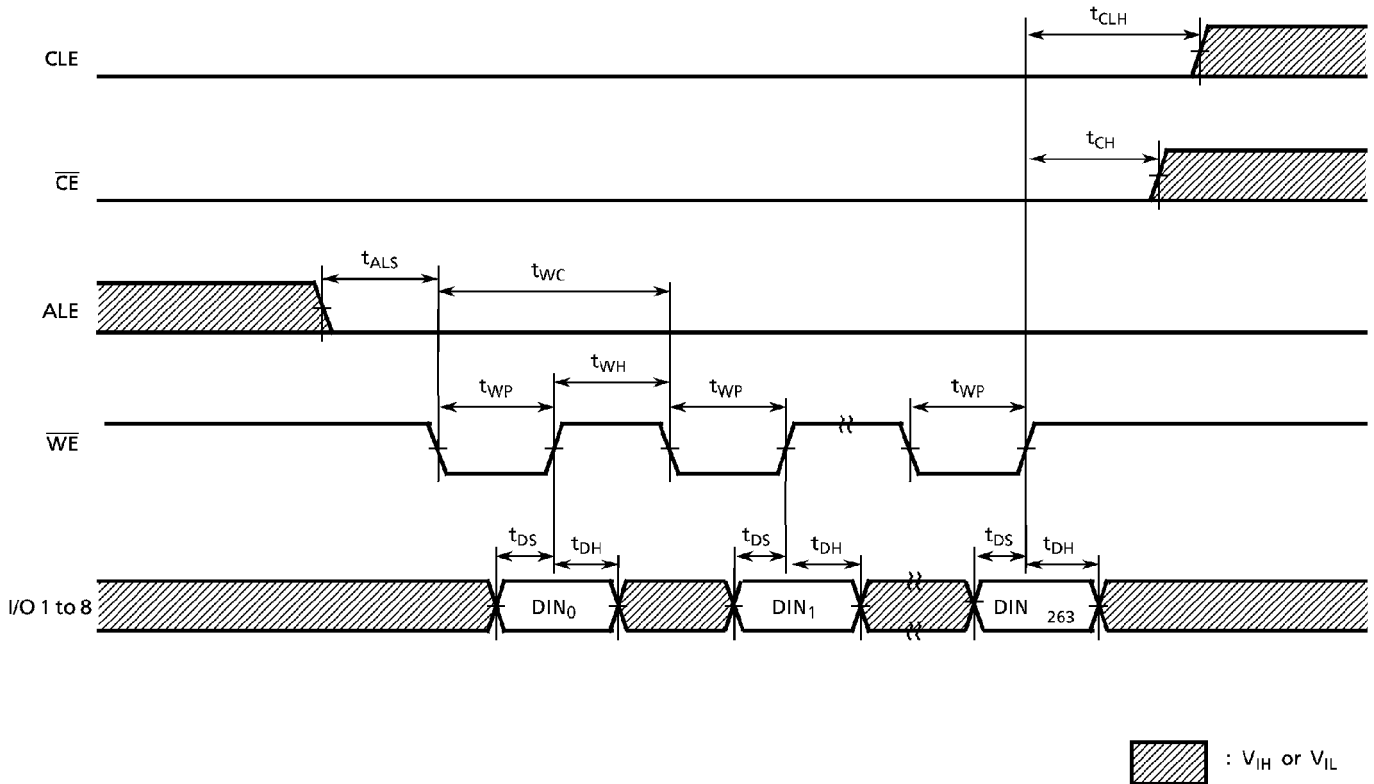

Serial Read Cycle Timing Diagram

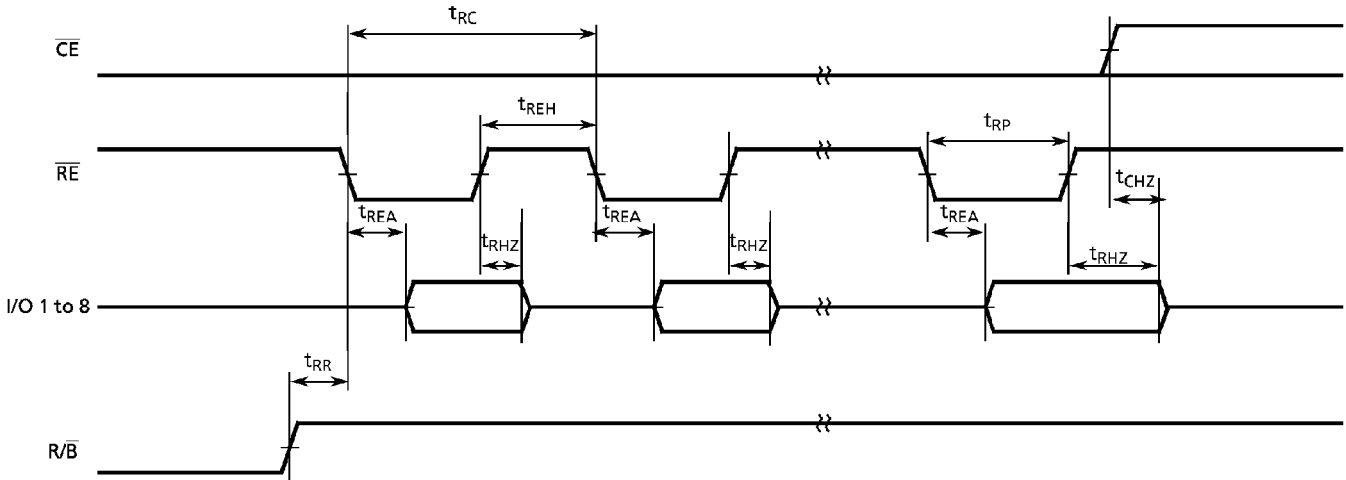

Status Read Cycle Timing Diagram

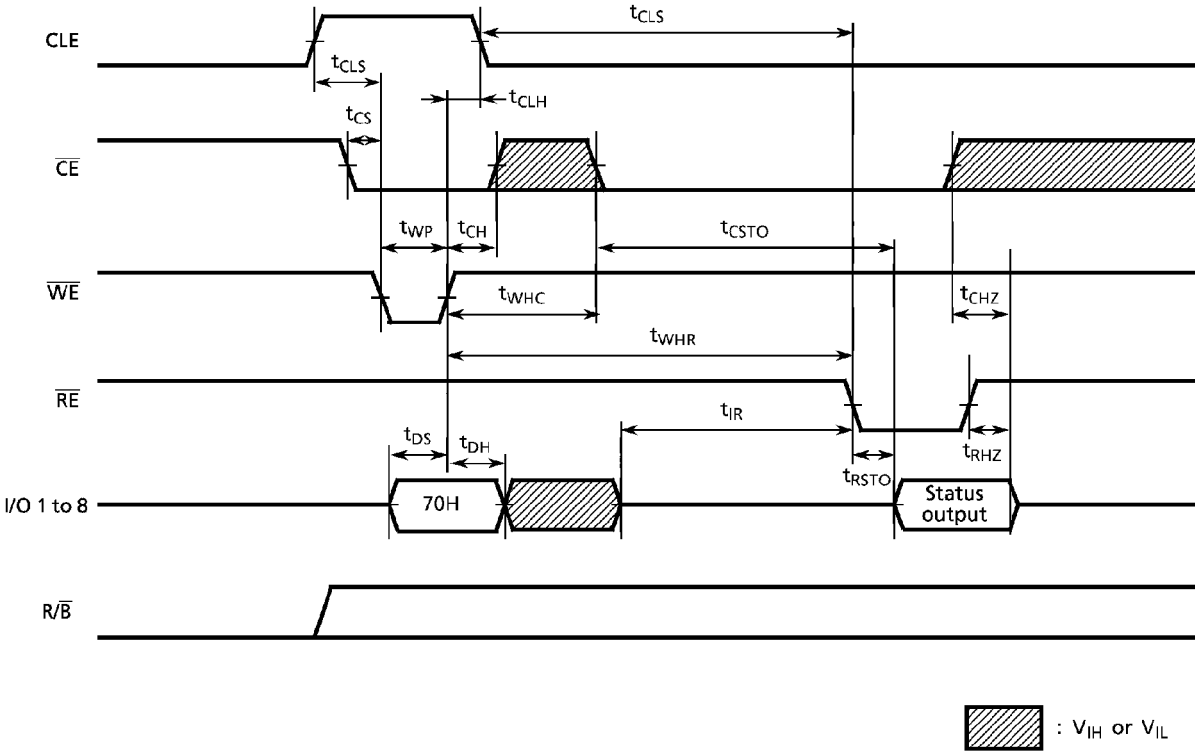

Read Cycle (1) Timing Diagram

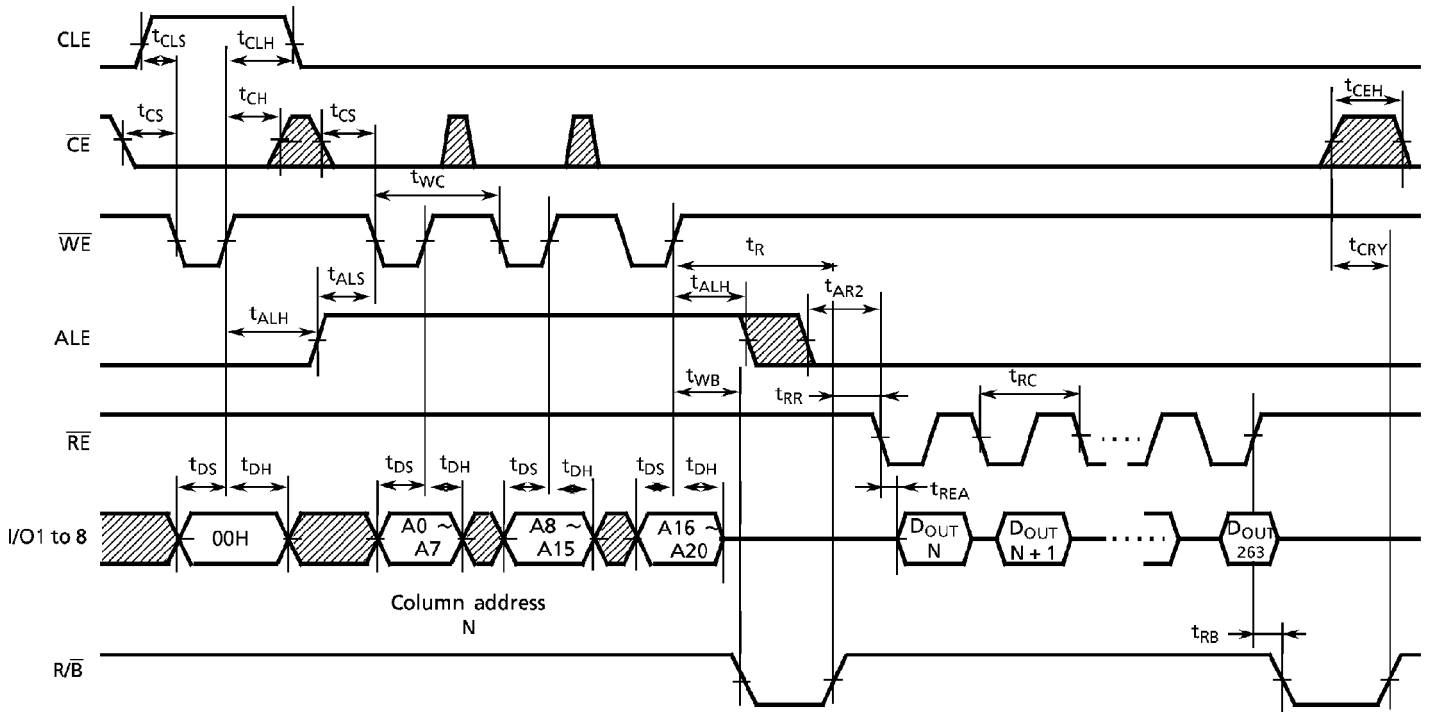

Read Cycle (1) Timing Diagram : Interrupted by \overline{CE}

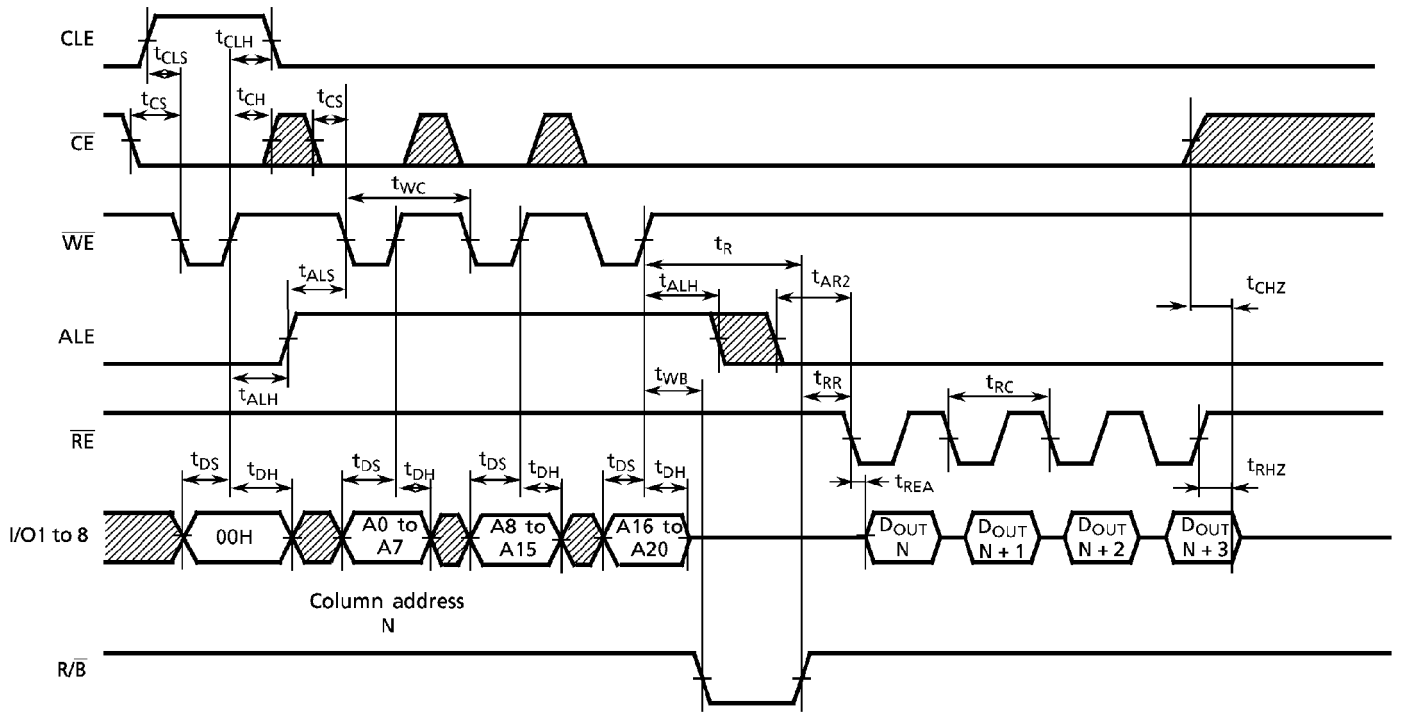

 V_{IH} または V_{IL}

Read Cycle (2) Timing Diagram

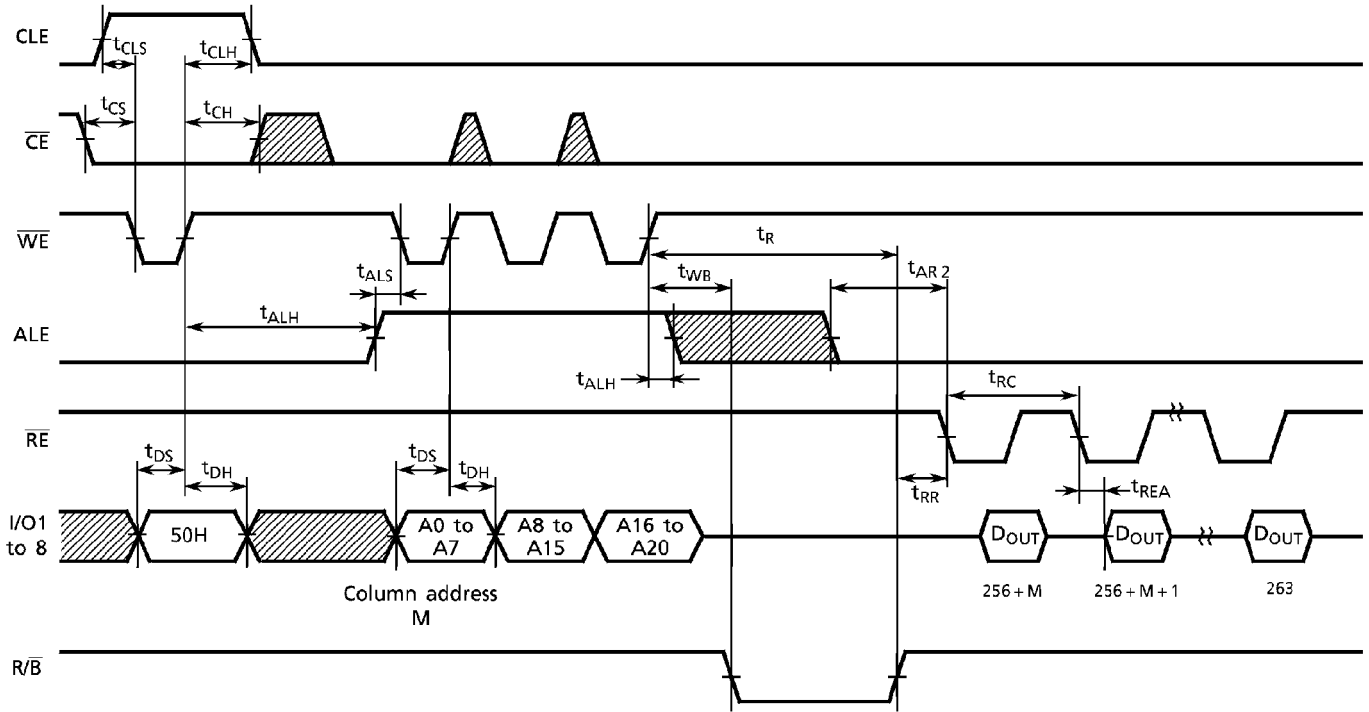

Sequential Read Timing Diagram

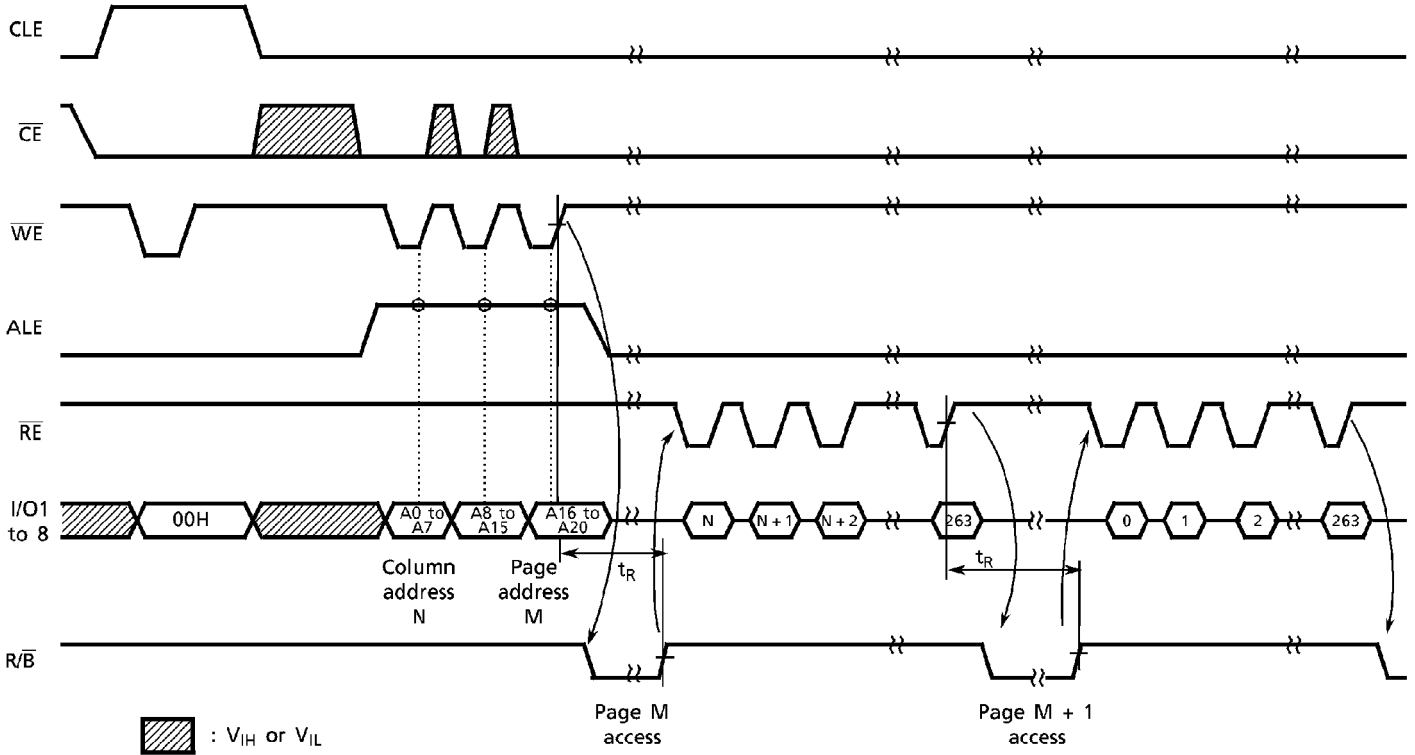

Auto Program Operation Timing Diagram

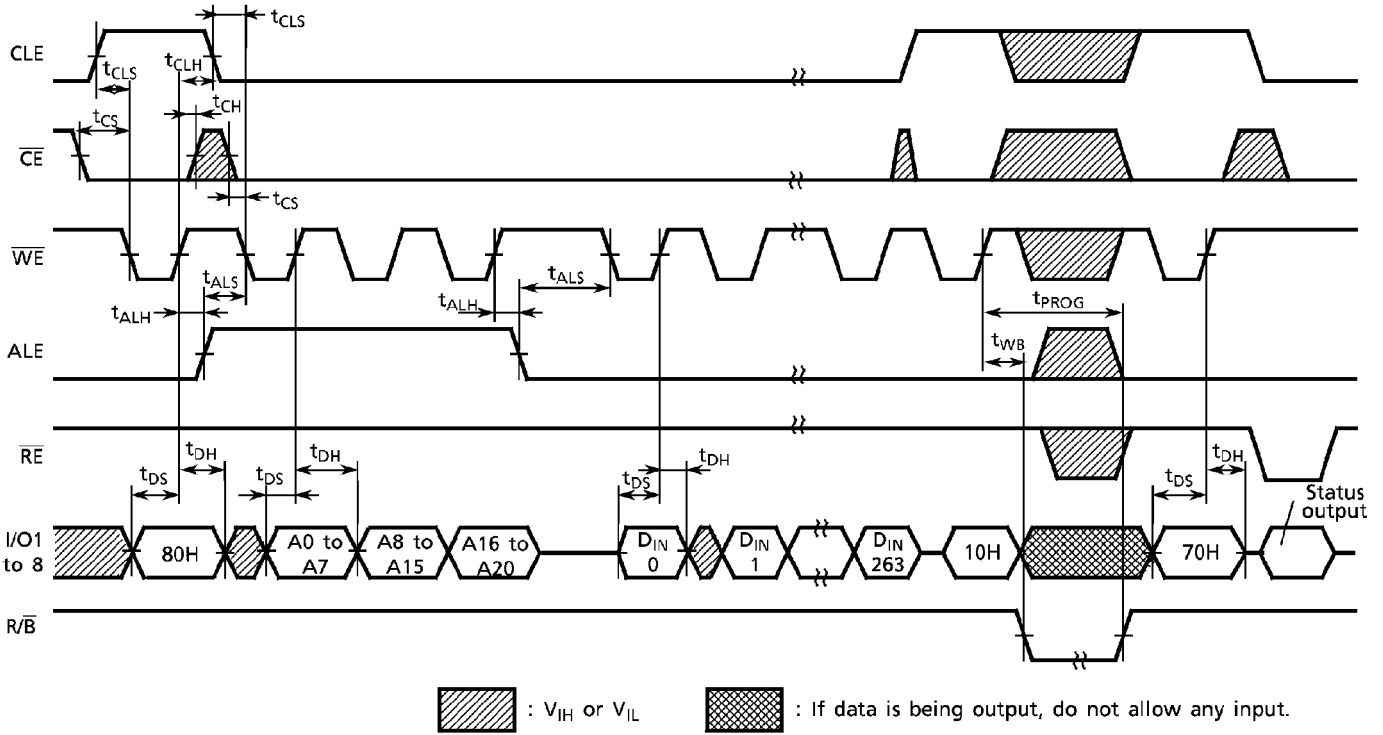

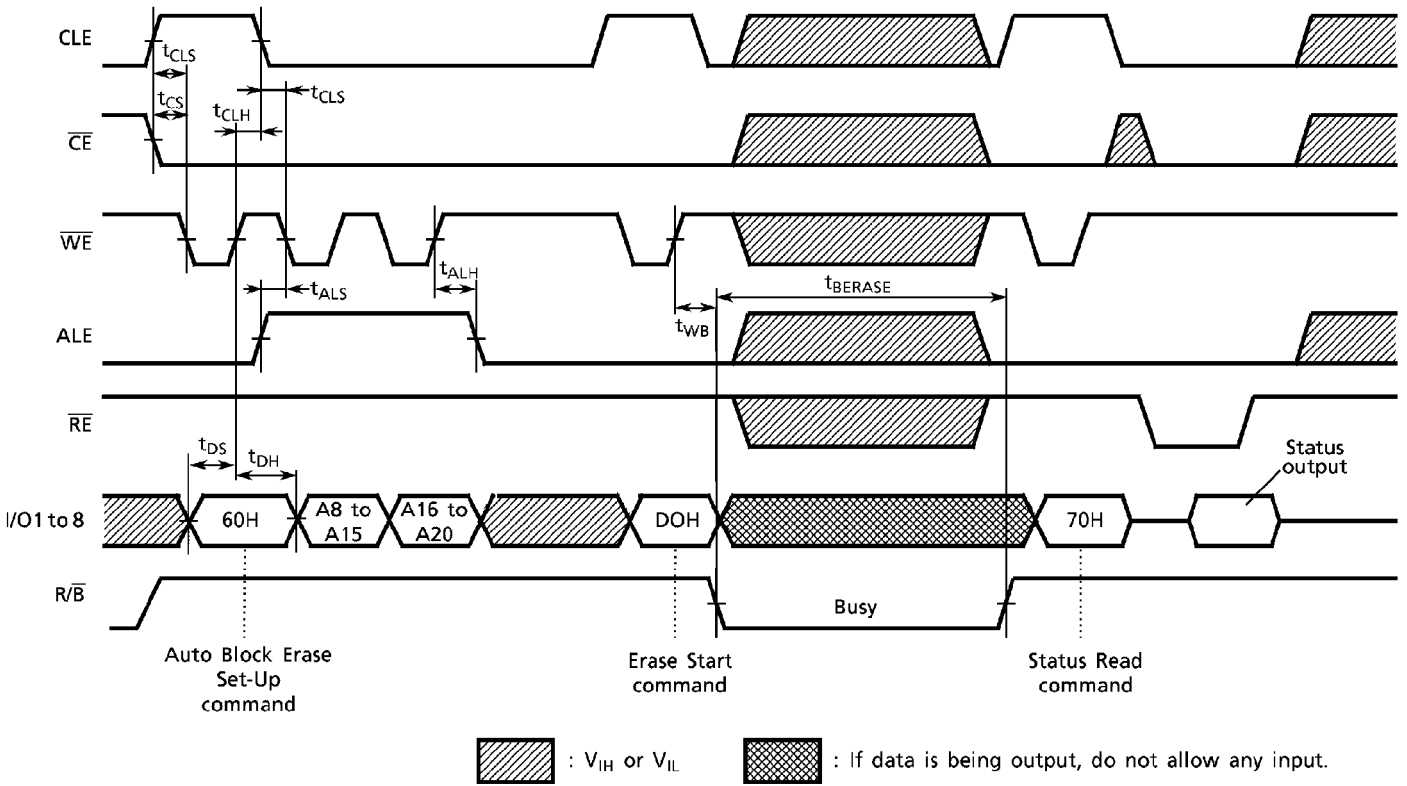

Auto Block Erase Timing Diagram

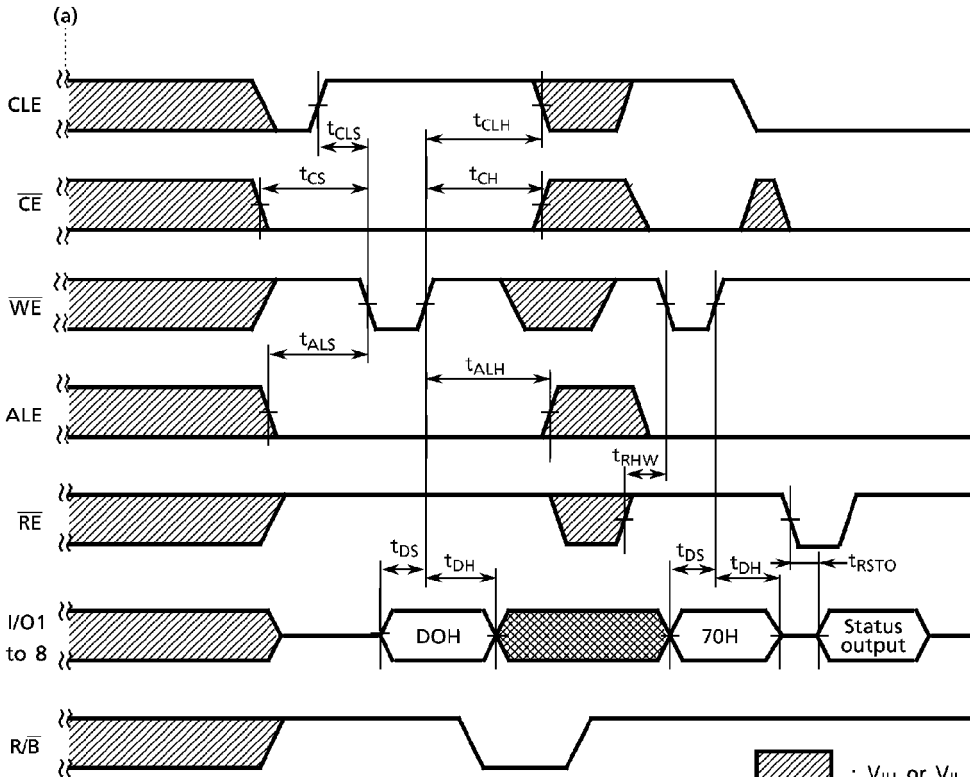
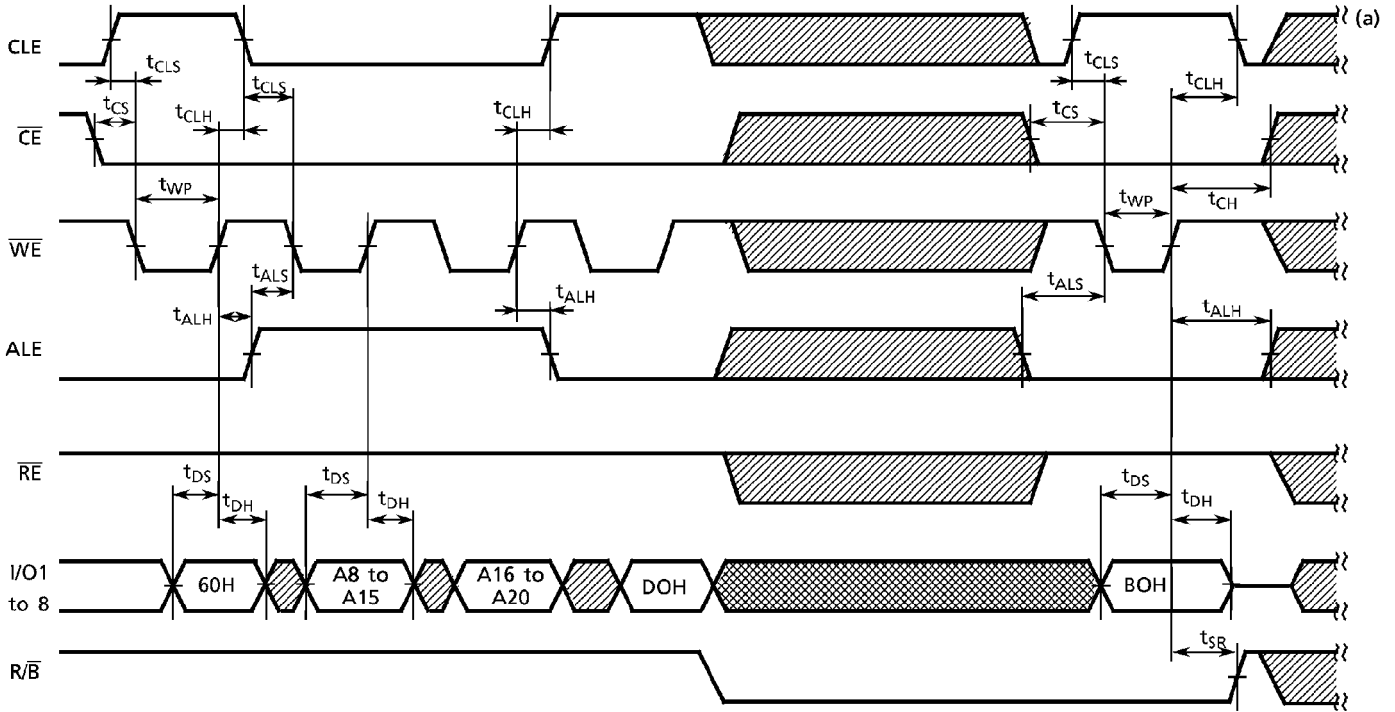

Suspend/Resume on Block Erase Operation Timing Diagram



(a): Continued

 : V_{IH} or V_{IL}
 : If data is being output, do not allow any input.

ID Read Operation Timing Diagram

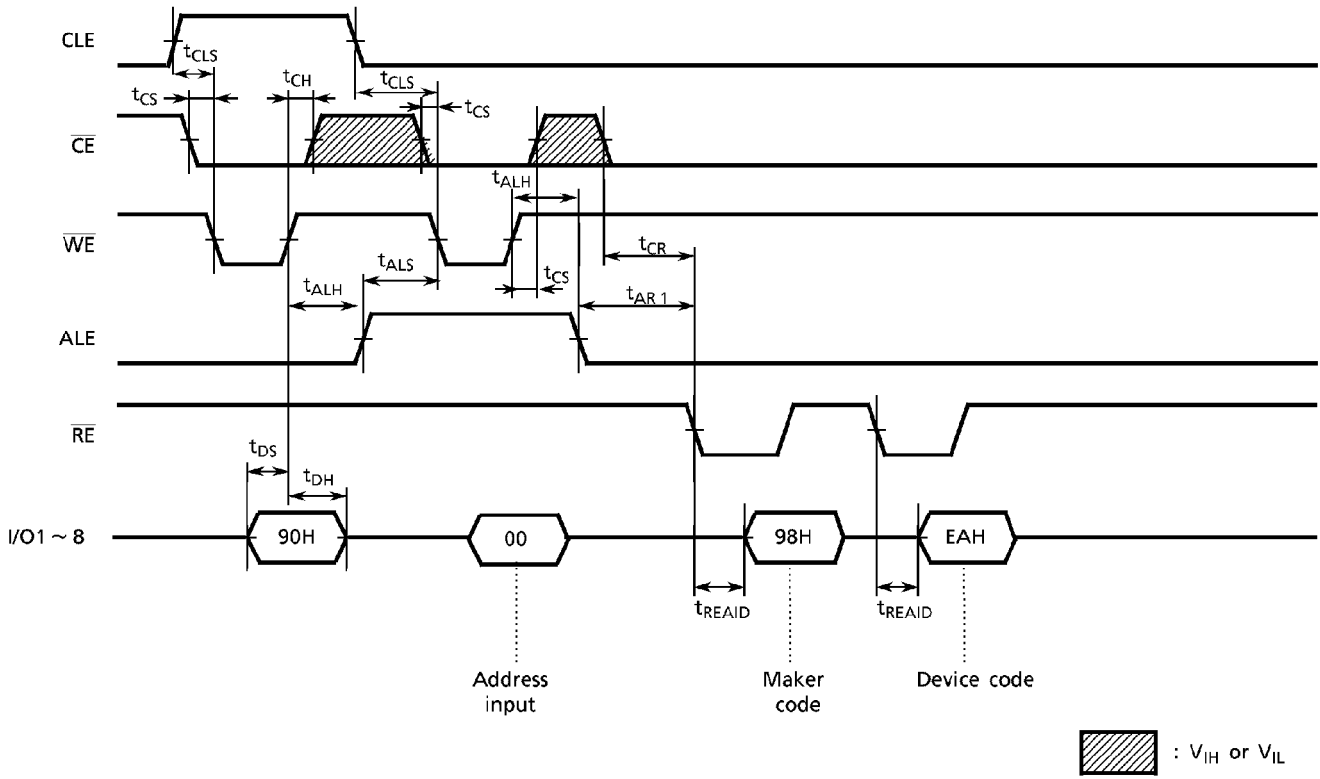

PIN FUNCTIONS

The TC58V16 is a serial access memory which utilizes time-sharing input of address information. The device pin-outs are configured as shown in Figure 1.

Command Latch Enable: CLE

The CLE input signal is used to control the acquisition of the operation mode command into the internal command register. The command is latched into the command register from the I/O port on the rising edge of the \overline{WE} signal while CLE is high.

Address Latch Enable: ALE

The ALE signal is used to control the acquisition of either address information or input data into the internal address/data register. Address information is latched on the rising edge of \overline{WE} if ALE is high. Input data is latched if ALE is low.

Chip Enable: \overline{CE}

The device goes into a low power standby mode during a Read operation when \overline{CE} goes high. The \overline{CE} signal is ignored when the device is in the Busy state ($R/\overline{B} = L$), such as during a Program or Erase operation, and will not go into Standby mode even if a \overline{CE} high signal is input.

Write Enable: \overline{WE}

The \overline{WE} signal is used to control the acquisition of data from the I/O port.

Read Enable: \overline{RE}

The \overline{RE} signal controls serial data output. Data is available t_{REA} after the falling edge of \overline{RE} . The internal column address counter is also incremented (Address + 1) on this falling edge.

I/O Port: I/O 1 to 8

The I/O 1 to 8 pins are used as the port for transferring address, command and input/output data information to or from the device.

Write Protect: \overline{WP}

The \overline{WP} signal is used to protect the device from accidental programming or erasing. The internal voltage regulator is reset when \overline{WP} is low. This signal is usually used for protecting the data during the power on/off sequence when input signals are invalid.

Ready/Busy: R/\overline{B}

The R/\overline{B} output signal is used to indicate the operating condition of the device. The R/\overline{B} signal is in a busy state ($R/\overline{B} = L$) during the Program, Erase and Read operations and will return to a ready state ($R/\overline{B} = H$) after completion of the operation. The output buffer for this signal is an open drain.

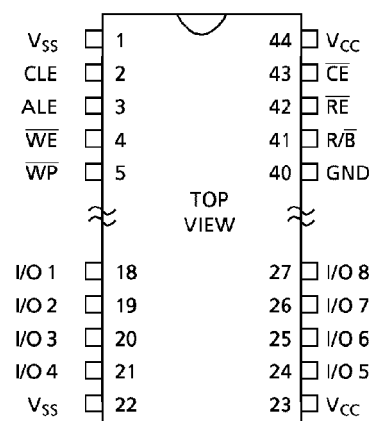

Figure 1. TC58V16 Pinout

Schematic Cell Layout and Address Assignment

The program operation is implemented in page units while the erase operation is carried out in block units.

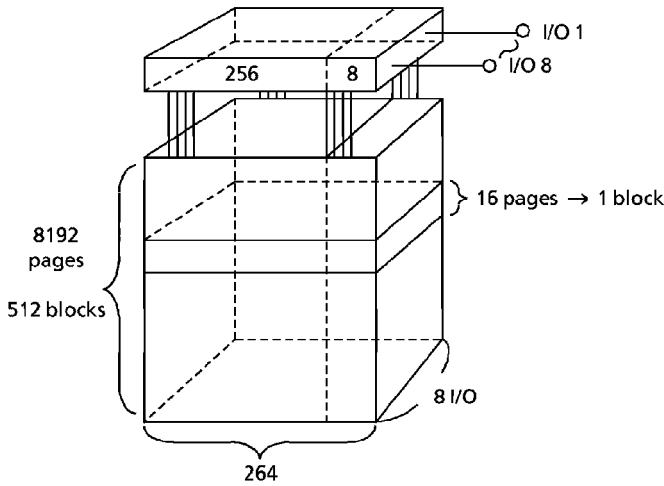

Figure 2. TC58V16 Schematic Cell Layout

A page consists of 264 bytes in which 256 bytes are for main memory and 8 bytes are for redundancy or other uses.

- 1 Page = 264 bytes
- 1 Block = 264 bytes × 16 pages = (4 K + 128) bytes
- Total Device Density = 264 bytes × 16 pages × 512 blocks = 16.5 Mbits (2.0625 Mbytes)

The address is acquired through the I/O port over three consecutive clock cycles as shown in Table 1.

Table 1. Addressing

	I/O 1	I/O 2	I/O 3	I/O 4	I/O 5	I/O 6	I/O 7	I/O 8
First cycle	A0	A1	A2	A3	A4	A5	A6	A7
Second cycle	A8	A9	A10	A11	A12	A13	A14	A15
Third cycle	A16	A17	A18	A19	A20	* L	* L	* L

- A0 to A7 : column address
- A8 to A20 : page address
- A12 to A20: block address
- (A8 to A11 : NAND address in block)

*: I/O 6 to 8 must be set low in the third cycle.

Operation Mode: Logic and Command Tables

The operation modes such as Program, Erase, Read, Erase Suspend and Reset are controlled by the eleven different command operations shown in Table 2. The address, command input and data input/output are controlled by the CLE, ALE, \overline{CE} , \overline{WE} , \overline{RE} and \overline{WP} signals, as shown in Table 2.

Table 2. Logic Table

	CLE	ALE	\overline{CE}	\overline{WE}	\overline{RE}	\overline{WP}
Command Input	H	L	L		H	*
Data Input	L	L	L		H	*
Address Input	L	H	L		H	*
Serial Data Output	L	L	L	H		*
During Programming (Busy)	*	*	*	*	*	H
During Erasing (Busy)	*	*	*	*	*	H
Program, Erase Inhibit	*	*	*	*	*	L

H: V_{IH} , L: V_{IL} , *: V_{IH} or V_{IL}

Table 3. Command table (HEX data)

	FIRST CYCLE	SECOND CYCLE	ACCEPTABLE COMMAND WHILE BUSY
Serial Data Input	80	-	
Read Mode (1)	00	-	
Read Mode (2)	50	-	
Reset	FF	-	○
Auto Program	10	-	
Auto Block Erase	60	D0	
Suspend in Erasing	B0	-	○
Resume	D0	-	
Status Read	70	-	○
ID Read	90	-	

Bit assignment of HEX data (Example)

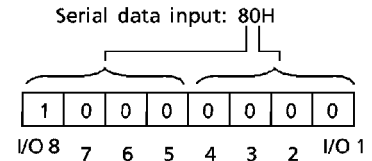

Once the device is set into Read mode by the “00H” or “50H” command, additional Read commands are not needed for sequential page read operations. Table 4 shows the operation states for Read Mode.

Table 4. Read mode operation states

	CLE	ALE	\overline{CE}	\overline{WE}	\overline{RE}	I/O 1 to I/O 8	POWER
Output Select	L	L	L	H	L	Data output	Active
Output Deselect	L	L	L	H	H	High impedance	Active
Standby	L	L	H	H	*	High impedance	Standby

DEVICE OPERATION

Read Mode (1)

Read mode (1) is set by issuing a “00H” command to the command register. Refer to Figure 3 below for timing details and a block diagram.

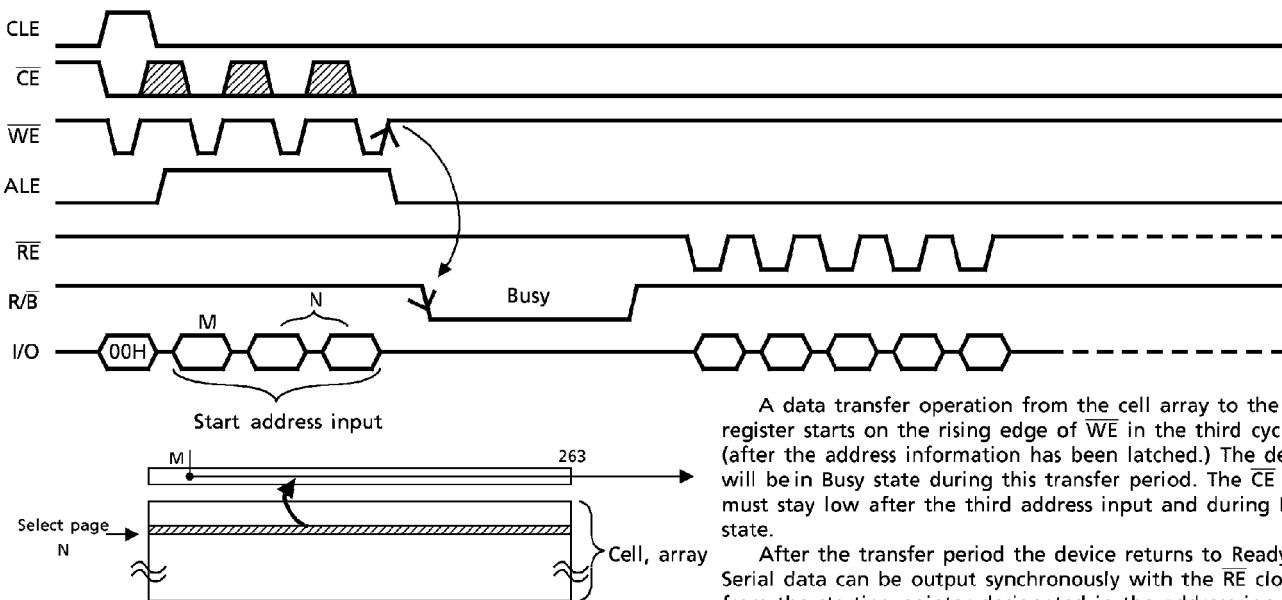

Figure 3. Read mode (1) operation

A data transfer operation from the cell array to the register starts on the rising edge of \overline{WE} in the third cycle (after the address information has been latched.) The device will be in Busy state during this transfer period. The \overline{CE} signal must stay low after the third address input and during Busy state.

After the transfer period the device returns to Ready state. Serial data can be output synchronously with the \overline{RE} clock from the starting pointer designated in the address input cycle.

Read Mode (2)

Read mode (2) has the same timing as Read mode (1) but is used to access information in the extra 8-byte redundancy area of the page. The starting pointer is therefore assigned between bytes 256 and 263.

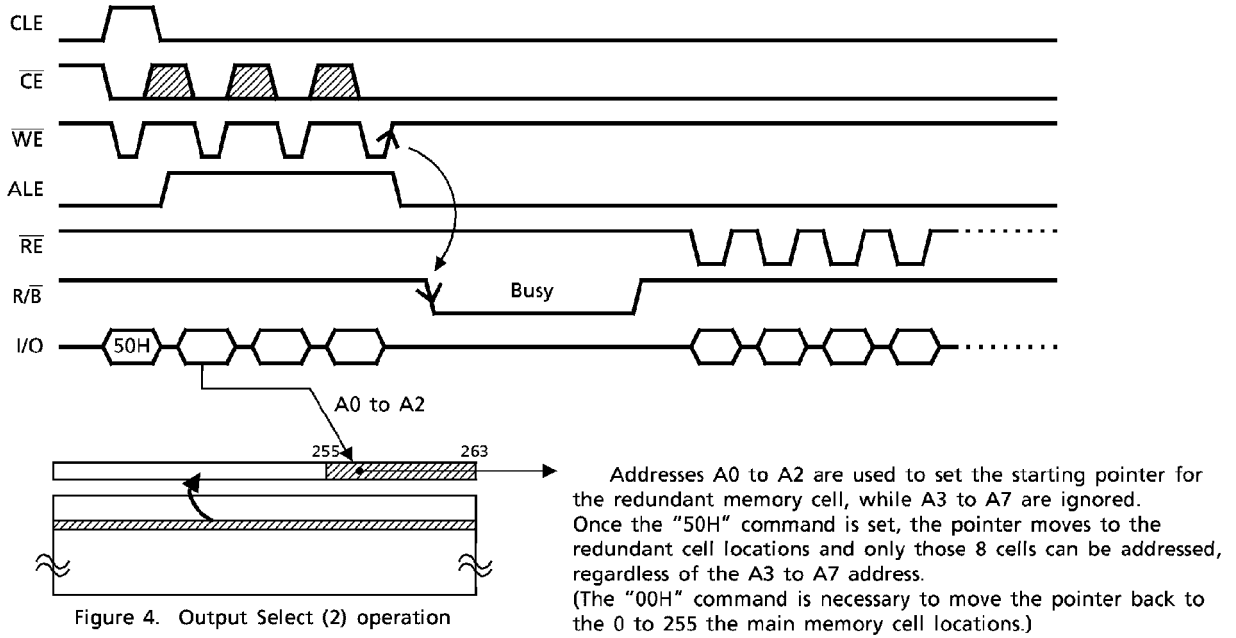

Figure 4. Output Select (2) operation

Sequential Read (1) (2)

This mode allows sequential reading without the additional address input.

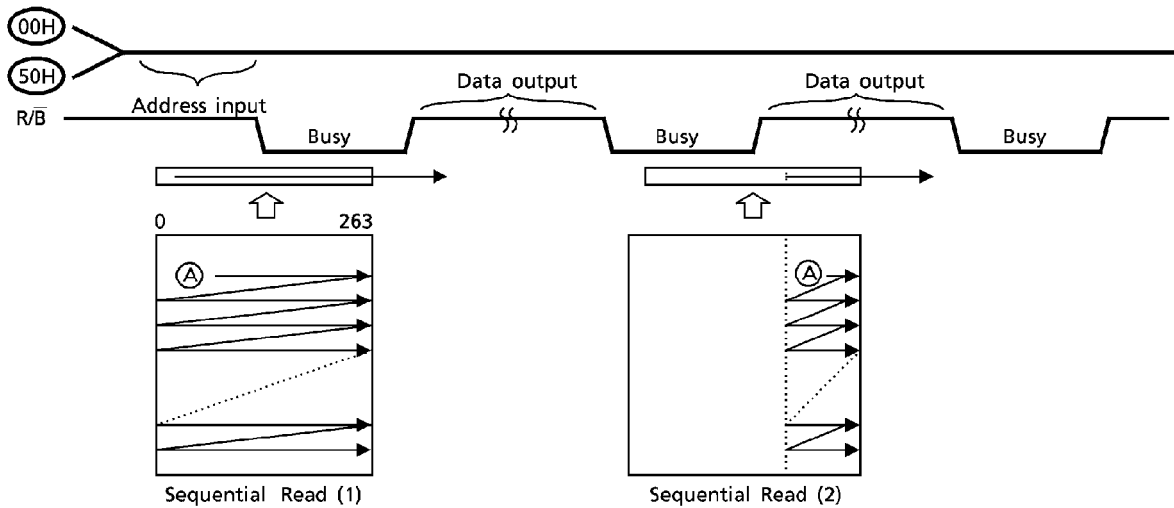

Figure 5. Sequential Read operation

Sequential Read mode (1) outputs addresses 0 to 263 while Sequential Read mode (2) outputs the redundant address locations only. When the pointer reaches the last address, the device continues to output the last data from this address on each RE clock signal.

Status Read

The TC58V16 automatically implements the execution and verification of the Program and Erase operations. The Status Read function is used to monitor the Ready/Busy status of the device, determine the pass/fail result of a Program or Erase operation, and determine if the device is in Suspend or Protect mode. The device status is output through the I/O port using the RE clock after a "70H" command input. The resulting information is outlined in Table 5.

Table 5. Status output table

	STATUS	OUTPUT	
I/O 1	Pass/Fail	Pass: "0"	Fail: "1"
I/O 2	Not used	"0"	
I/O 3	Not used	"0"	
I/O 4	Not used	"0"	
I/O 5	Not used	"0"	
I/O 6	Suspend	Suspended: "1"	Not Suspended: "0"
I/O 7	Ready/Busy	Ready: "1"	Busy: "0"
I/O 8	Write Protect	Protect: "0"	Not Protect: "1"

The Pass/Fail status on I/O 1 is only valid when the device is in the Ready state. The device will always indicate Fail Status while in the Busy state in the Program and Erase operations.

An application example with multiple devices is shown in Figure 6.

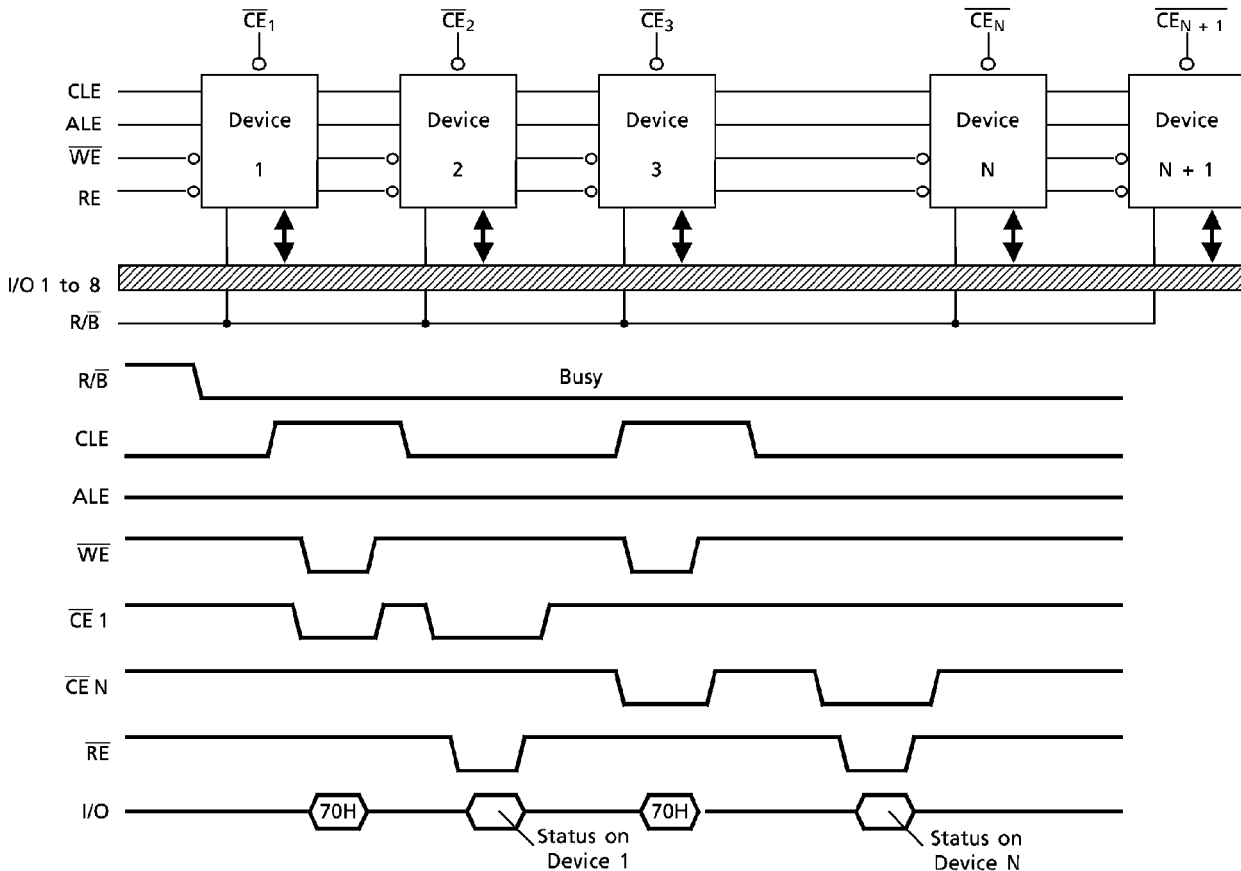
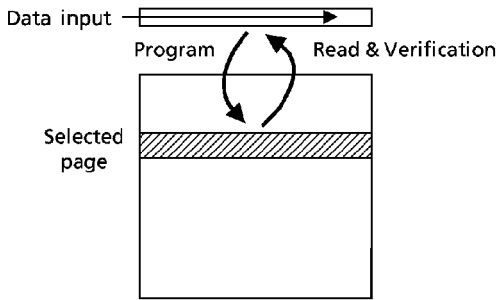
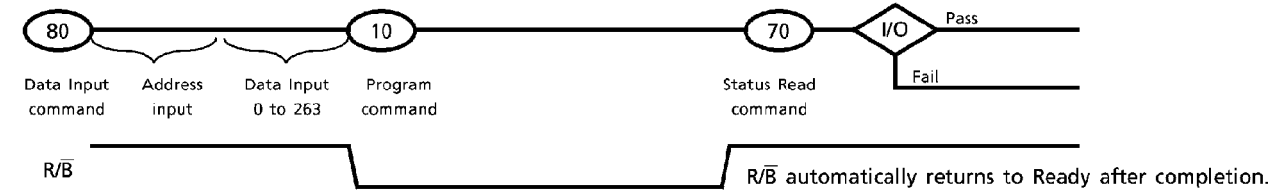

Figure 6. Status Read Timing Application Example

SYSTEM DESIGN NOTE: If the R/B pin signals of multiple devices are common-wired, as shown in the diagram, the Status Read Function can be used to determine the status of each individually selected device.

Auto Page Program

The TC58V16 implements the Automatic Page Program operation by receiving a "10H" program command after the address and data have been input. The sequence of command, address and data input is shown below. (Refer to the detailed timing chart.)



The data is transferred (programmed) from the register to the selected page on the rising edge of WE following the "10H" command input. After programming the programmed data is transferred back to the register to be automatically verified by the device. If the program does not succeed, the above Program/Verify operation is repeated by the device until success is achieved or until the maximum loop number set in the device is reached.

Figure 7. Auto Page Program Operation

Auto Block Erase

The Auto Block Erase operation starts on the rising edge of \overline{WE} after the Erase start command "D0H" which follows the Erase Set-Up command "60H". This two-cycle process for Erase operations acts as an extra layer of protection from accidental erasure of data due to external noise. The device automatically executes the Erase and Verify operations.

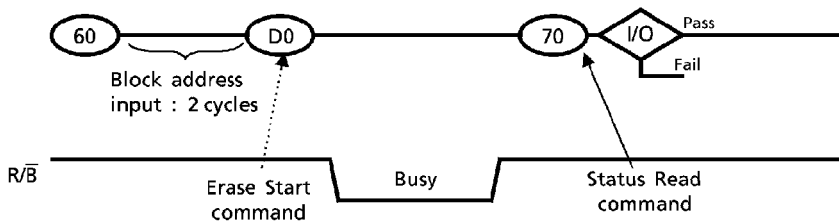

Figure 8. Auto Block Erase

Suspend/Resume

Because a Block Erase operation can keep the device in the Busy state for an extended period of time, the TC58V16 has the ability to suspend the Erase operation in order to allow Program or Read operations to be performed on the device. The block diagram and command sequence for this operation are shown as below. (Refer to the detailed timing chart)

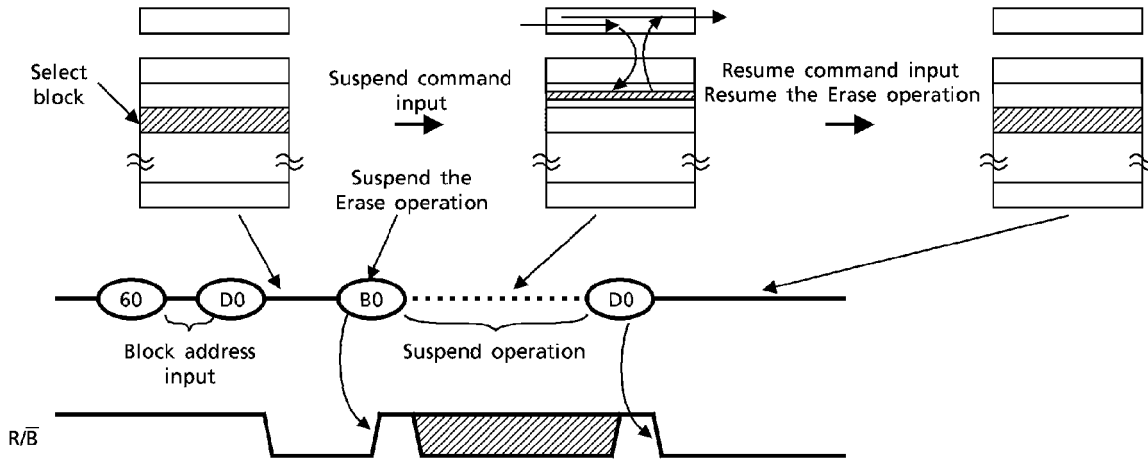

Figure 9. Suspend/Resume Operation

The **B0**...**D0** Suspend/Resume cycle can be repeated up to 20 times during a Block Erase operation. After the Resume command has been input, the Erase operation continues from the point at which it left off and does not have to be restarted.

Reset

The Reset mode stops all operations. For example, in the case of a Program or Erase operation, the regulated voltage is discharged to 0 volts and the device will go into Wait state. The address and data register are set as follows after a Reset:

- Address Register : All "0"
- Data Register : All "1"
- Operation Mode : Wait State

The response after an "FFH" Reset command input during each operation is as follows:

- When a Reset (FFH) command is input during programming. Figure 10.

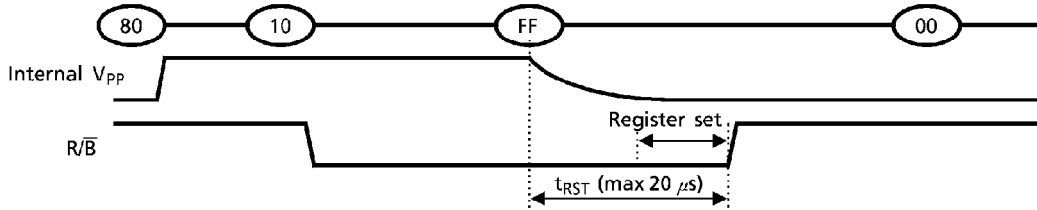

- When a Reset (FFH) command is input during erasing. Figure 11.

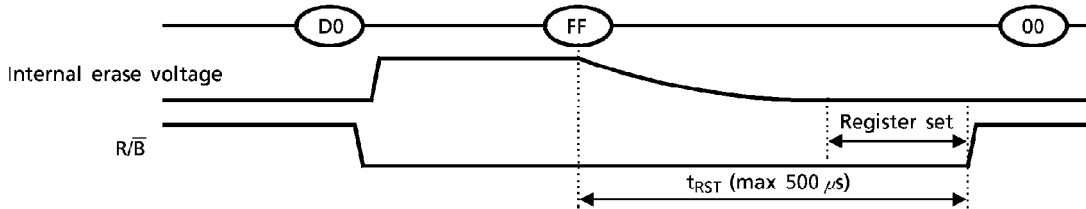

- When a Reset (FFH) command is input during a Read operation. Figure 12.

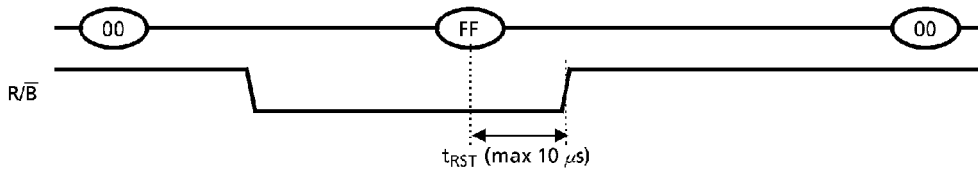

- When a Reset (FFH) command is input after Suspend. Figure 13.

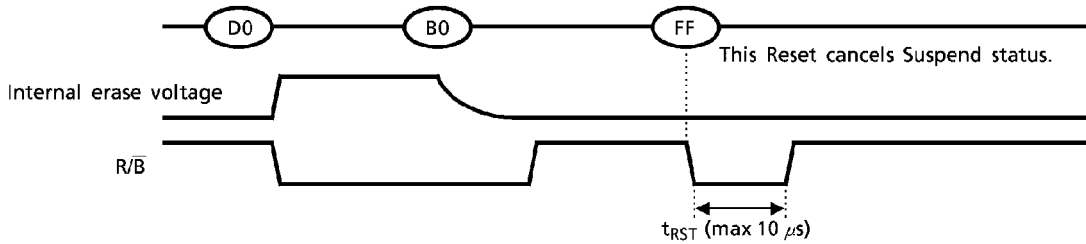

- When a Status Read command (70H) is input after a Reset.

Figure 14.

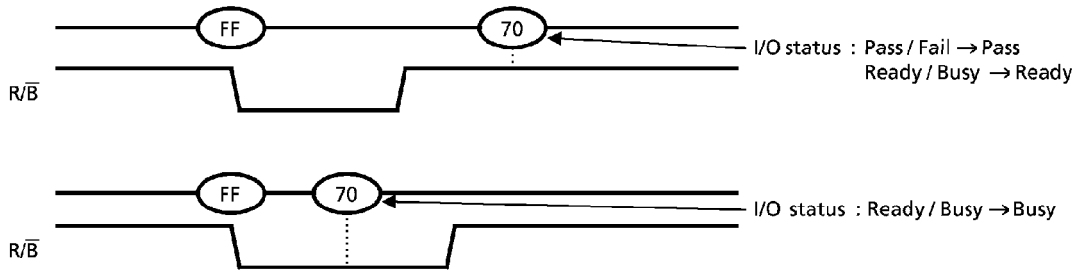

- When more than one Reset commands are input in succession.

Figure 15.

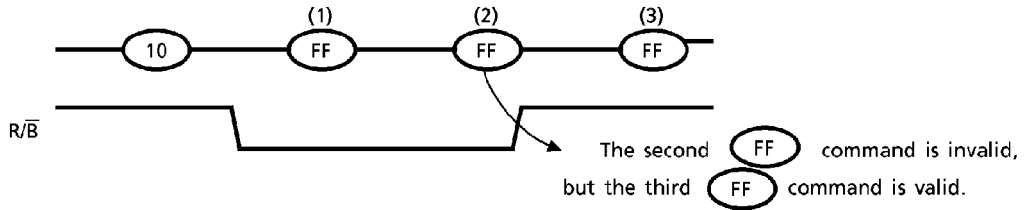

ID READ

The TC58V16 contains an ID code to identify the device type and the manufacturer. The ID codes are read out using the following timing conditions:

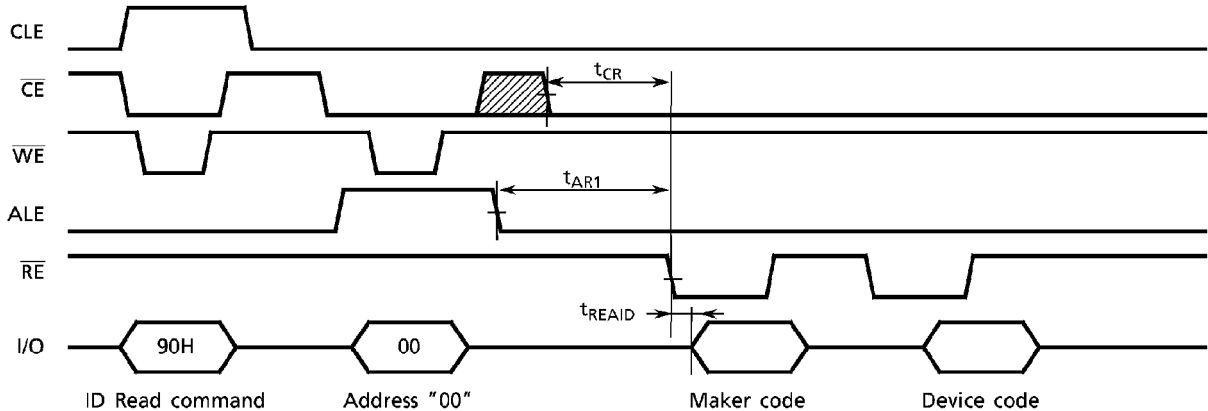

Figure 16. ID Read timing

Table 6. Code table

	I/O 8	I/O 7	I/O 6	I/O 5	I/O 4	I/O 3	I/O 2	I/O 1	HEX DATA
Maker code	1	0	0	1	1	0	0	0	98H
Device code	1	1	1	0	1	0	1	0	EAH

Refer to the specifications for the t_{READ} , t_{CR} and t_{AR1} access timings.

DEVICE PHYSICS:

Program Operation

Figure 17 shows the NAND memory cell level details of the programming mechanism. The Program operation is used to write “0” data into an erased memory cell (“1” data cell) using a tunneling mechanism. An example Program operation to program “0” data into TR1 and “1” data into TR2 is as follows:

- (1) A high level is applied to Select line 1 and a low level is applied to Select line 2 so that the device is connected to the Bit line and disconnected from the ground line.
- (2) V_{pp} ($\approx 20\text{ V}$) is applied to the selected word line and an inhibit voltage of V_{PI} ($\approx 10\text{ V}$) is applied to the unselected word lines.
- (3) 0 volts is applied to the bit line tied to cell transistor TR1 and the inhibit voltage V_{DPI} ($\approx 10\text{ V}$) is applied to the bit line tied to TR2.
- (4) V_{pp} is applied between the control gate and the channel in TR1, as shown in Figure 18, which causes electrons to be injected from the channel to the floating gate by a tunneling mechanism.
- (5) The injected electrons are captured in the floating gate surrounded by an oxide layer and will remain, even after power is cut off, until they are removed by an Erase operation.
- (6) Although 20 volts is applied to the control gate of TR2, the voltage difference between the control gate and the channel is only 10 V because the voltage of the channel is 10 V. Therefore, tunneling does not take place (i.e. the electron is not injected into the floating gate.)
- (7) Tunneling does not take place in the unselected pages because of the 10 V (V_{PI}) applied to the unselected word lines which makes the voltage difference between the control gate and channel only 10 volts.

Thus the floating gate of the “0” cell is charged to “Minus” and that of the “1” cell is charged to “Plus”.

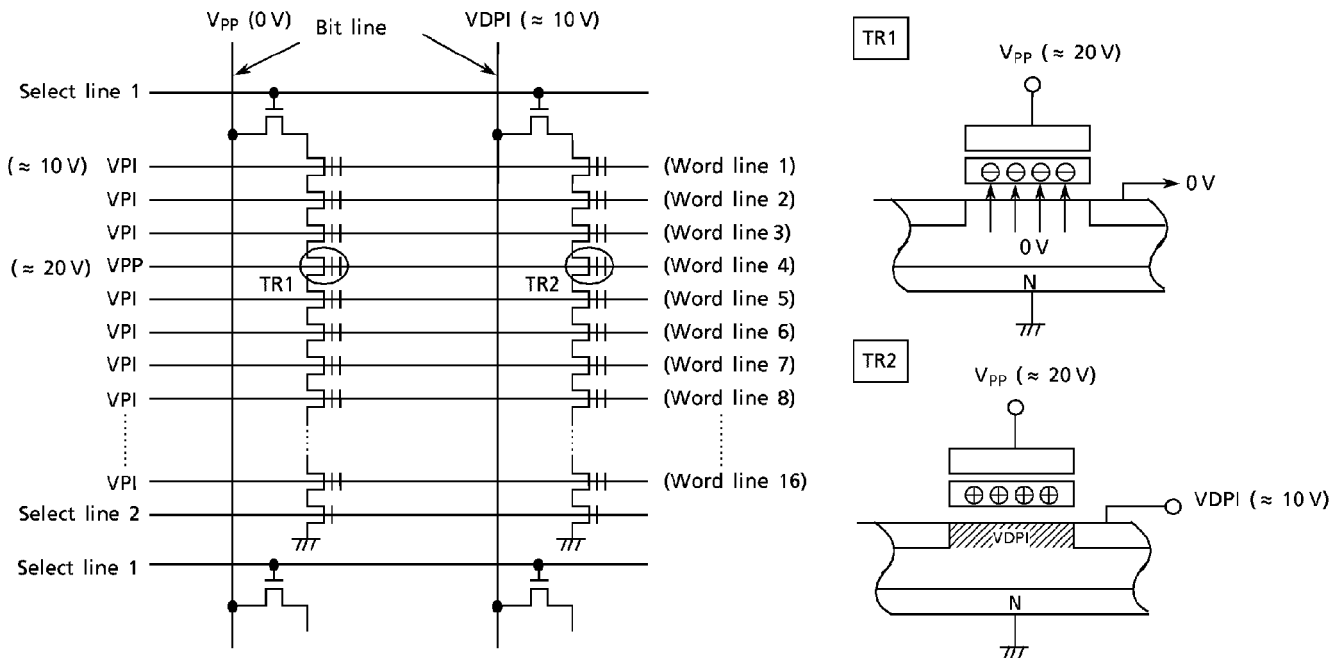

Figure 17. TC58V16 Program Device Physics

Erase Operation

Figure 18 shows the NAND memory cell level details of the Erase mechanism. The Erase operation is used to turn the "0" (programmed) cells back to "1" in a block. The captured electrons are pulled out from the floating gate to the substrate by a tunneling mechanism. 0 volts is applied to the control gate and V_{pp} ($\approx 20\text{ V}$) is applied to the substrate so that a 20-volt potential is created and the electrons in the floating gate are pulled out by the tunneling mechanism.

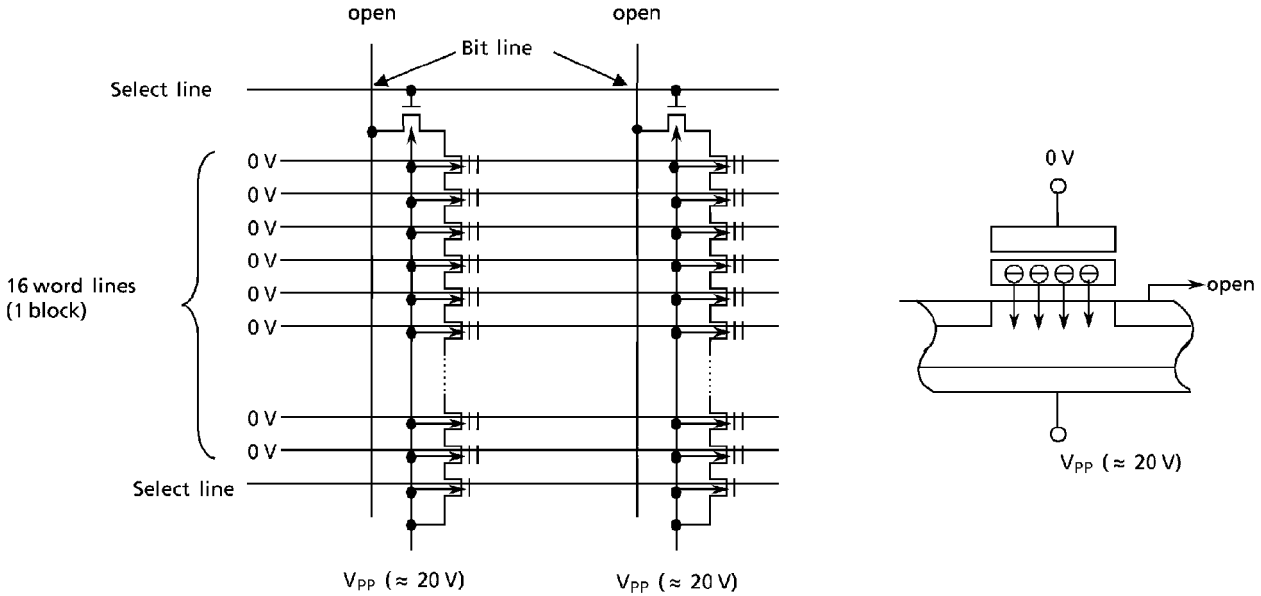

Figure 18. TC58V16 Erase Device Physics

Read Operation

After programming the state of the memory cell is either "0" (minus charge on the floating gate) or "1" (plus charge on the floating gate). Each state is indicated as the "threshold voltage (V_{th})" which is a characterization parameter of the MOS transistor as shown in Figure 19. The threshold voltage of a transistor with data "0" is distributed in the "plus" region while a transistor with data "1" is distributed in the "minus" region. The distribution band depends on the fluctuation of the transistor.

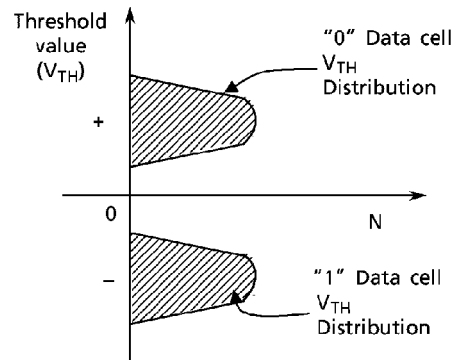

Figure 19. V_{TH} Distribution for "0" and "1" data cells

Figure 20 shows memory cell level details of the Read operation mechanism:

- (1) A high voltage is applied to Select lines 1 and 2 in the block which includes the selected page, so that the 16 NAND memory cells are connected to the Bit line and ground.
- (2) 0 volts is applied to the control gates of the selected page and a high level voltage is applied to the control gates of the unselected pages.
- (3) In Figure 20, transistor TR2 with data "1" turns on, transistor TR1 with data "0" turns off, and all other unselected transistors turn on.
- (4) The precharged bit line tied to TR2 is discharged through TR2 as cell current flows to ground, while the precharged bit line tied to TR1 remains high because current does not flow. The sense amplifiers tied to the bit lines thus sense the voltage levels as "1" and "0" respectively.

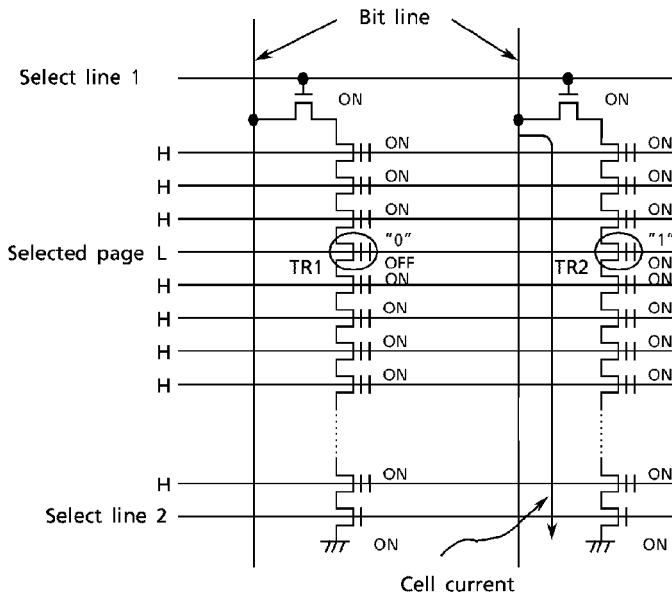

Figure 20. TC58V16 Read Device Physics

APPLICATION NOTES AND COMMENTS

(1) Prohibition of unspecified commands

The operation commands are listed in Table 3. Data input as a command other than the specified commands in Table 3 is prohibited. Stored data may be corrupted if an unspecified command is entered during the command cycle.

(2) Pointer control for "00H", "50H"

The TC58V16 has two Read modes to set the destination of the pointer in either the main memory area of a page or the redundancy area. The pointer can be designated at any location from 0 to 255 in Read mode (1) and from 256 to 263 in Read mode (2). Figure 21 shows a block diagram of the modes' operations.

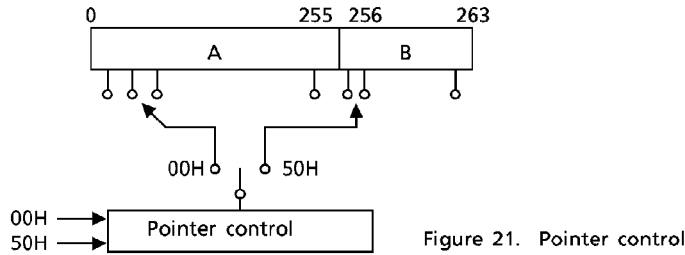

The pointer is set to region "A" by the "00H" command and to region "B" by the "50H" command.

(Example)

The "00H" command needs to be input to set the pointer back to region "A" when the pointer is in region "B".

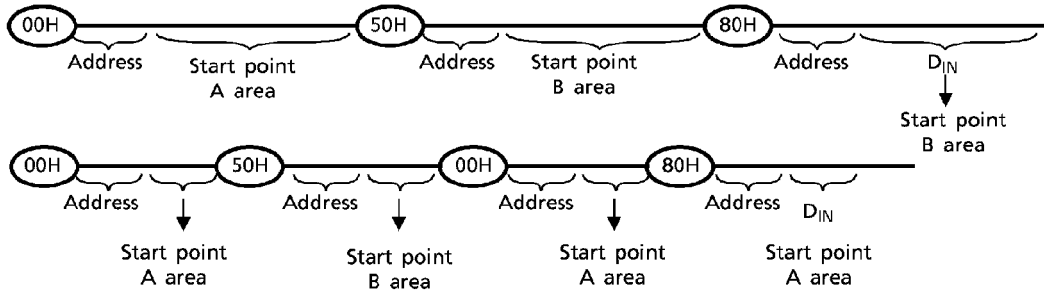
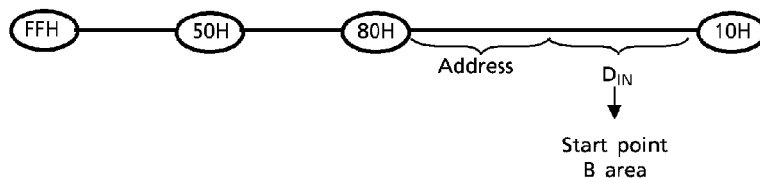

Figure 22. Example for Pointer Set

If the start point is set in region "B" using the "50H" command, so as to program region "B" only, the contents of the data register must be set to "1" in advance using the "FFH" command.



(3) Acceptable commands after Serial Input command "80H"

Once the Serial Input command ("80H") has been input, do not input any command other than the Program Execution command ("10H") or the Reset command ("FFH") during programming.

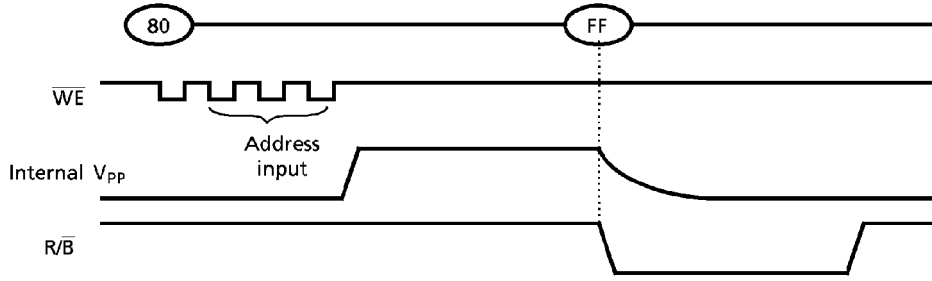
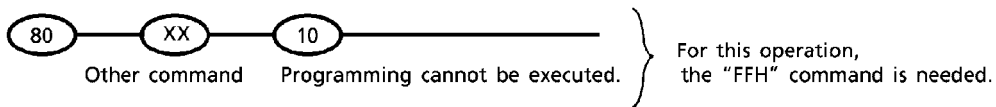

Figure 23.

If a command other than "10H" or "FFH" is input, the Program operation is not performed.



(4) Status Read during a Read operation

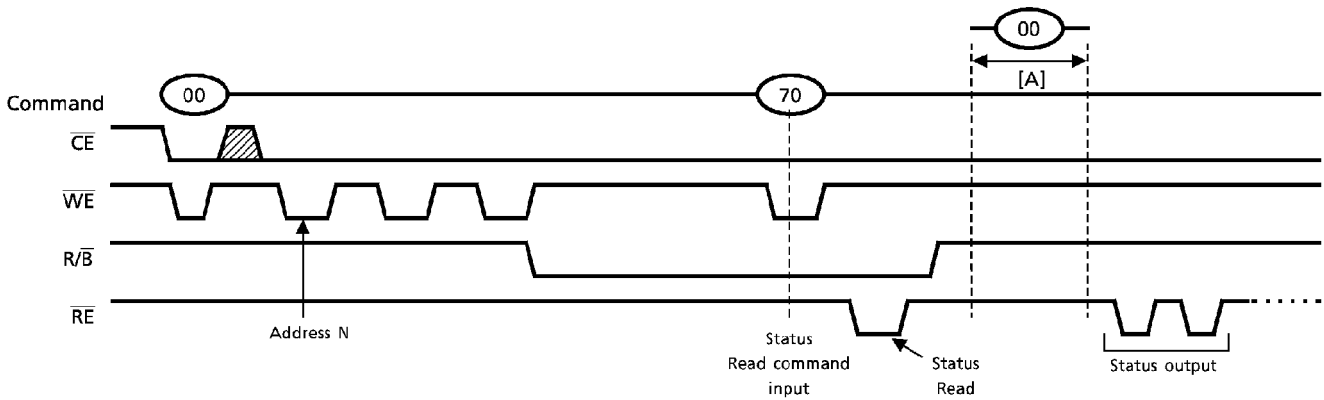

Figure 24.

The device status can be read out by inputting the Status Read command "70H" in Read mode. Once the device has been set to Status Read mode by a "70H" command, the device will not return to Read mode.

Therefore, Status Read during a Read operation is prohibited. However, when the Read command "00H" is input during [A], Status mode is reset and then the device returns to Read mode. In this case, data output starts from address N without the need for address input.

(5) Suspend command "B0H"

The following issues need to be observed when the device is interrupted by a "B0H" command during block erasing.

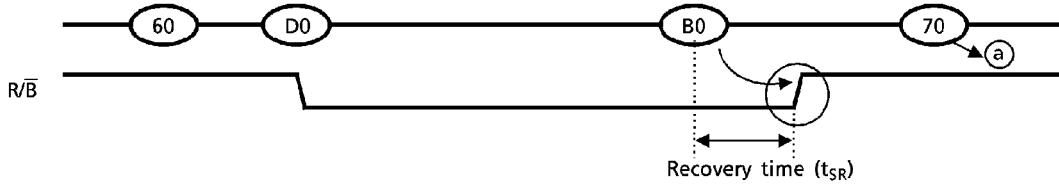

Figure 25.

The device status changes from Busy to Ready when "B0H" is input. However, the following two cases cannot be distinguished from one another.

- After a "B0H" command input, Busy → Ready
- After an Erase operation is completed with a "D0H" command, Busy → Ready

Therefore, the device status needs to be checked to see whether or not the "B0H" command has been accepted by issuing a "70H" command after the device goes to Ready.

The device responds as follows when a "D0H" command (Resume) is input instead of "70H".

- "B0H" has been accepted
 - : Erase operation is executed. (The device is Busy.)
- "B0H" has not been accepted. (Erase operation has been completed)
 - : "D0H" command cannot be accepted. (The device is Ready.)

The two cases above can be checked by monitoring the R/B signal.

(6) When auto programming fails.

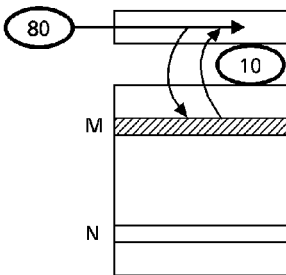
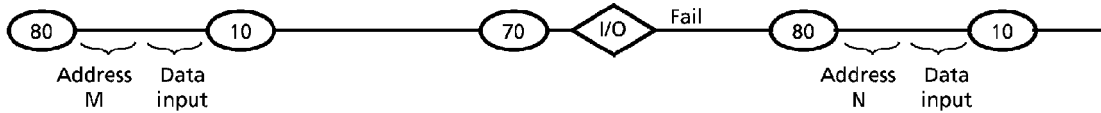

If the programming result for page address M is "Fail", do not try to program the page to address N in another block. Because the previous input data is lost, the same sequence of "80H" command, address and data input is necessary.

Figure 26.

(7) Data transfer

The data in page address M cannot be automatically transferred to page address N. If the following sequence is executed, the data will be inverted. (i.e. "1" data will become "0" and "0" will become "1".)

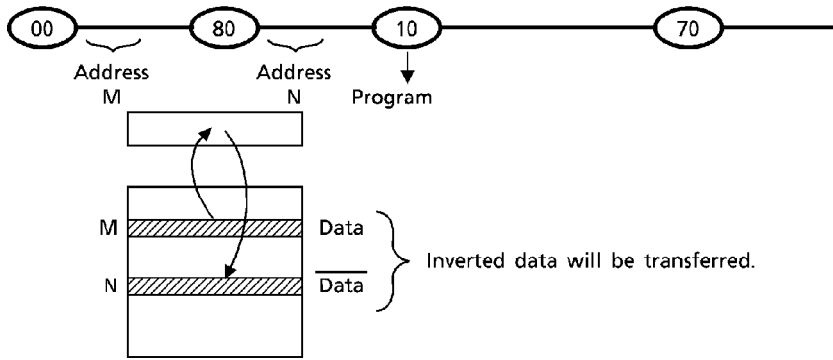
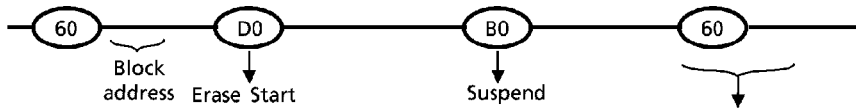

Figure 27.

(8) Block Erase After Suspend command "B0H"



A Block Erase command is prohibited when the device has been suspended by the input of a "B0H" command during a Block Erase operation. Only a Program or Read operation is allowed during this Erase Suspend interruption.

(9) Interruption of block erasure

After the input of a "B0H" command, neither a Program nor a Read operation is allowed for the block which is currently being erased.

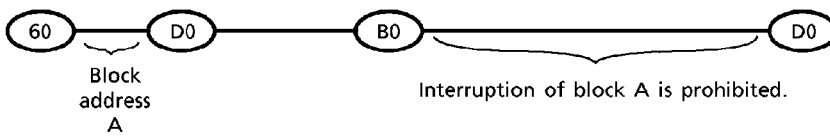

(10) $\overline{R/B}$: Termination for the Ready/Busy pin ($\overline{R/B}$)

A pull-up resistor must be used for termination because the $\overline{R/B}$ buffer consists of an open drain circuit.

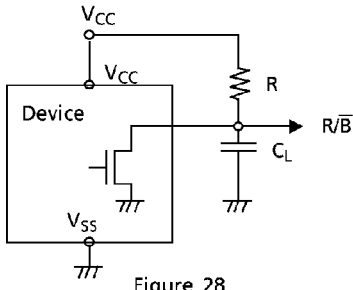
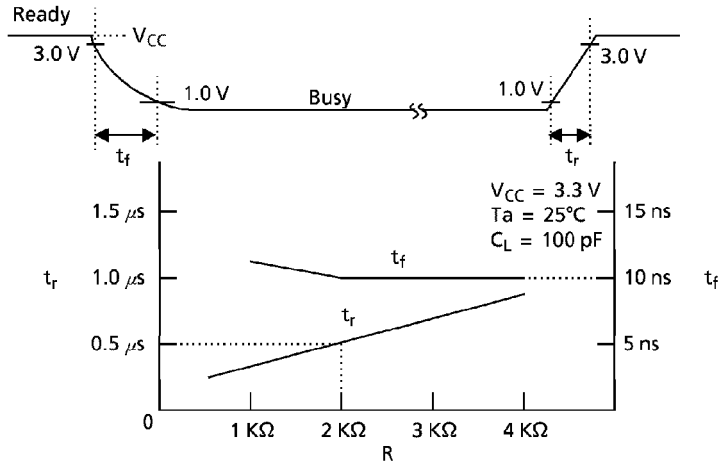

Figure 28.

This data may vary from device to device. We recommend that you use this data as a reference when selecting a resistor value.



(11) Status after Power On

Although the device is set to Read mode after power-up, the following sequence is needed because all input signals may not be stable at power on.

- Operating mode : Read mode (1)
- Address register : All "0"
- Data register : Indeterminate
- High voltage generation circuit: Off state

Power on sequence

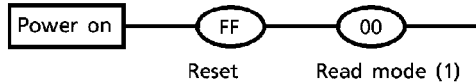

(12) Power On/Off Sequence:

The \overline{WP} signal is useful for protecting against data corruption at power on/off. The following timing is recommended:

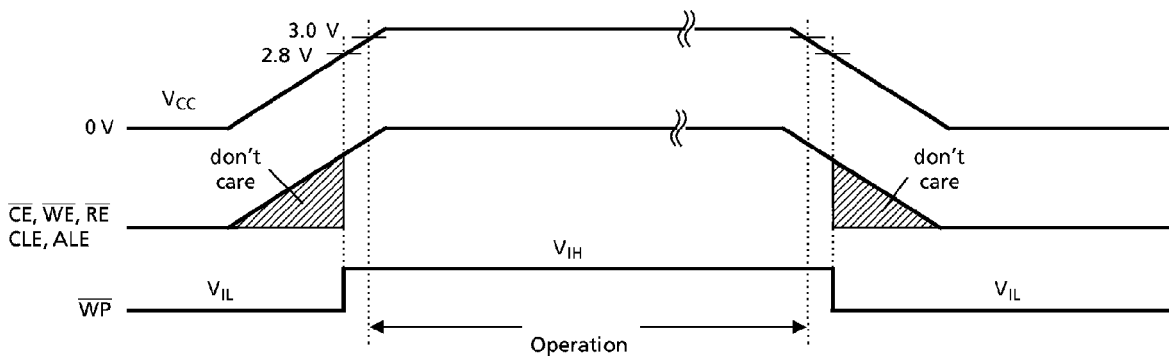

Figure 29. TC58V16 Power On/Off Sequence

(13) Note regarding the \overline{WP} Signal

The Erase and Program operations are automatically reset when \overline{WP} goes low. The \overline{WP} signal must be kept high before the input of a "80H"/"60H" command, the Program and Erase commands.

If \overline{WP} goes high after a Program ("80H") or Erase ("60H") command, the Program or Erase operation cannot be guaranteed.

Program

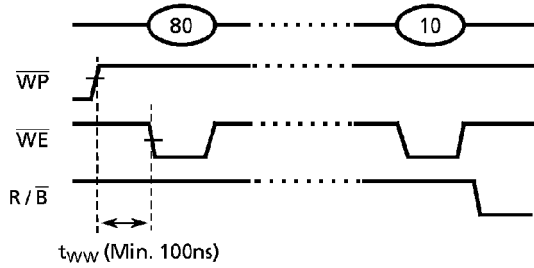

Figure 30.

Erase

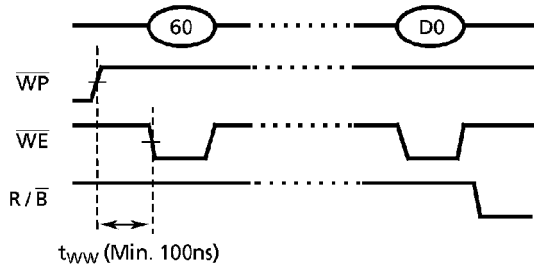
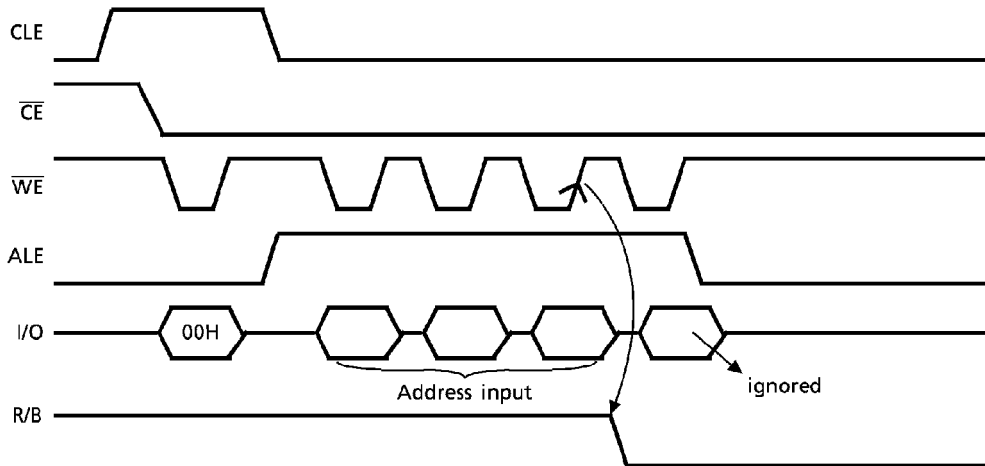

Figure 31.

(14) When four address cycles are input

Although the device may acquire the fourth address, it is ignored inside the chip.

Read operation



Internal read operation starts when WE goes high in the third cycle.

Figure 32.

Programming operation

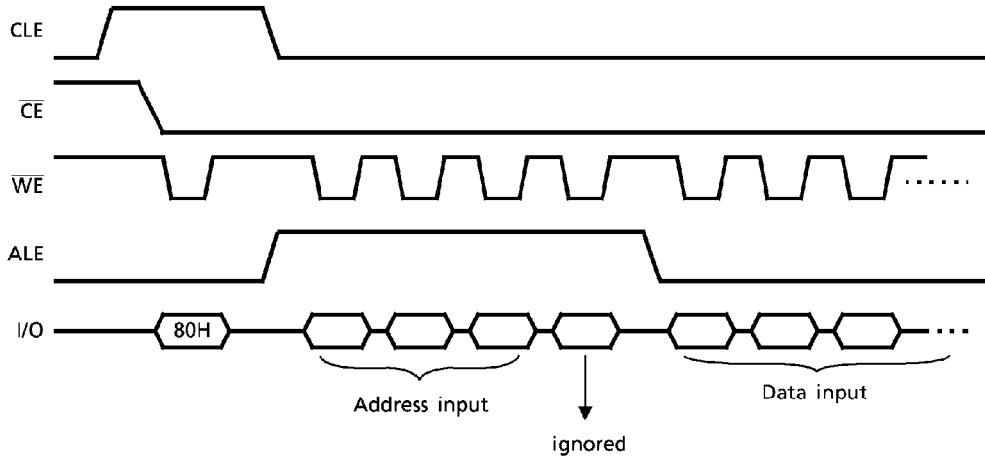

Figure 33.

(15) Number of programming cycle on the same page (Partial Page Program)

A page can be divided into up to 10 segments. Each segment can be programmed individually as shown below.

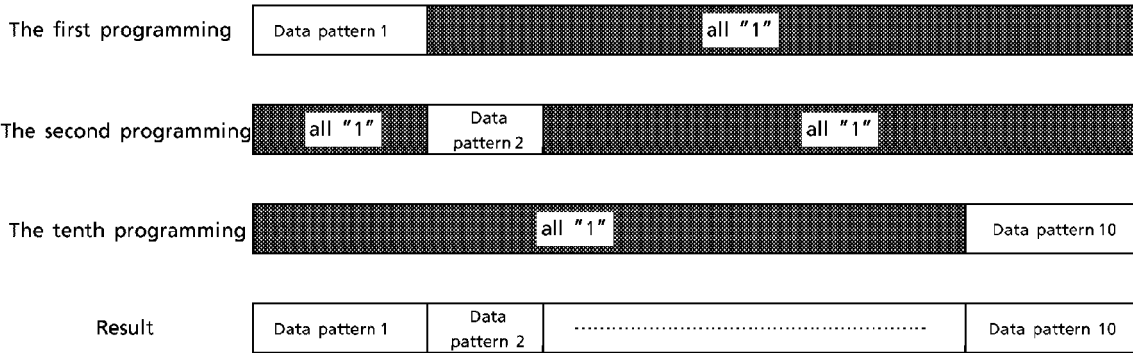

Figure 34.

Note: The input data for unprogrammed or previously programmed page segments must be "1". (i.e. Set all page bytes outside the segment to be programmed to "1".)

(16) Note regarding the \overline{RE} Signal

The internal column address counter is incremented synchronously with the \overline{RE} clock in Read mode. Therefore, once the device has been set to Read mode by the "00H" or "50H" command, the internal column address counter is incremented by the \overline{RE} clock independent of the timing of the address input. If the \overline{RE} clocks are input before address input and the pointer reaches the last column address, an internal read operation (array → register) will occur and the device will be in the Busy state. (Refer to Figure 35.)

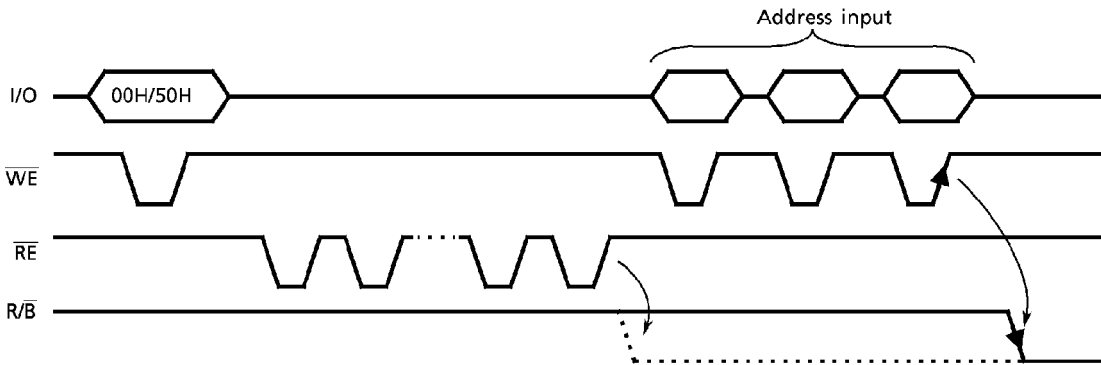
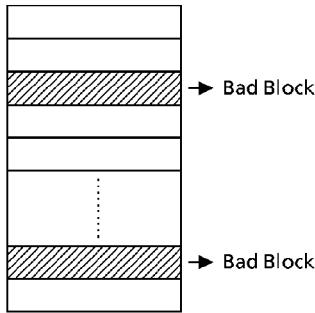

Figure 35.

Hence, the \overline{RE} clocks must be input after address input.

(17) Invalid block (bad block)

The TC58V16 device occasionally contains unusable blocks. Therefore, the following issues must be recognized:



Check whether the device has any bad blocks after installation of the device in the system. Do not try to access bad blocks. A bad block does not affect the performance of good blocks as it is isolated from the Bit line by the Select gate. Valid numbers of blocks are as follows:

	MIN	TYP	MAX	UNIT
Valid Good Block Number	502	508	512	Block

Figure 36 shows the bad block test flow.

(18) Failure Phenomena for Program and Erase Operations.

The device may fail during program or erase operation.

The following possible failure modes should be considered when implementing a highly reliable system.

FAILURE MODE		DETECTION AND COUNTERMEASURE SEQUENCE
Block	Erase Failure	Status Read after Erase → Block Replacement
Page	Program Failure	Status Read after Prog. → Block Replacement
Single Bit*	Program Failure '1' → '0'	(1) Block Verify after Prog. → Retry
		(2) ECC

* : (1) or (2)

- ECC : Error Correcting code → Hamming Code etc.
Example : 1 bit correction & 2 bit detection.
- Block Replacement

Program

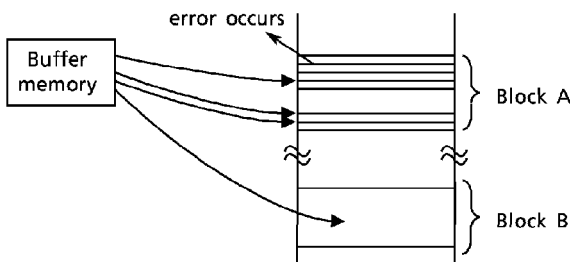

When an error happens in Block A, try to reprogram the data into another (Block B) by loading from an external buffer. Then, prevent further system accesses to Block A (by creating a 'bad block' table or an another appropriate scheme.)

Erase

When an error occurs for an erase operation, prevent future accesses to this bad block (again by creating a table within the system or other appropriate scheme).

BAD BLOCK TEST FLOW

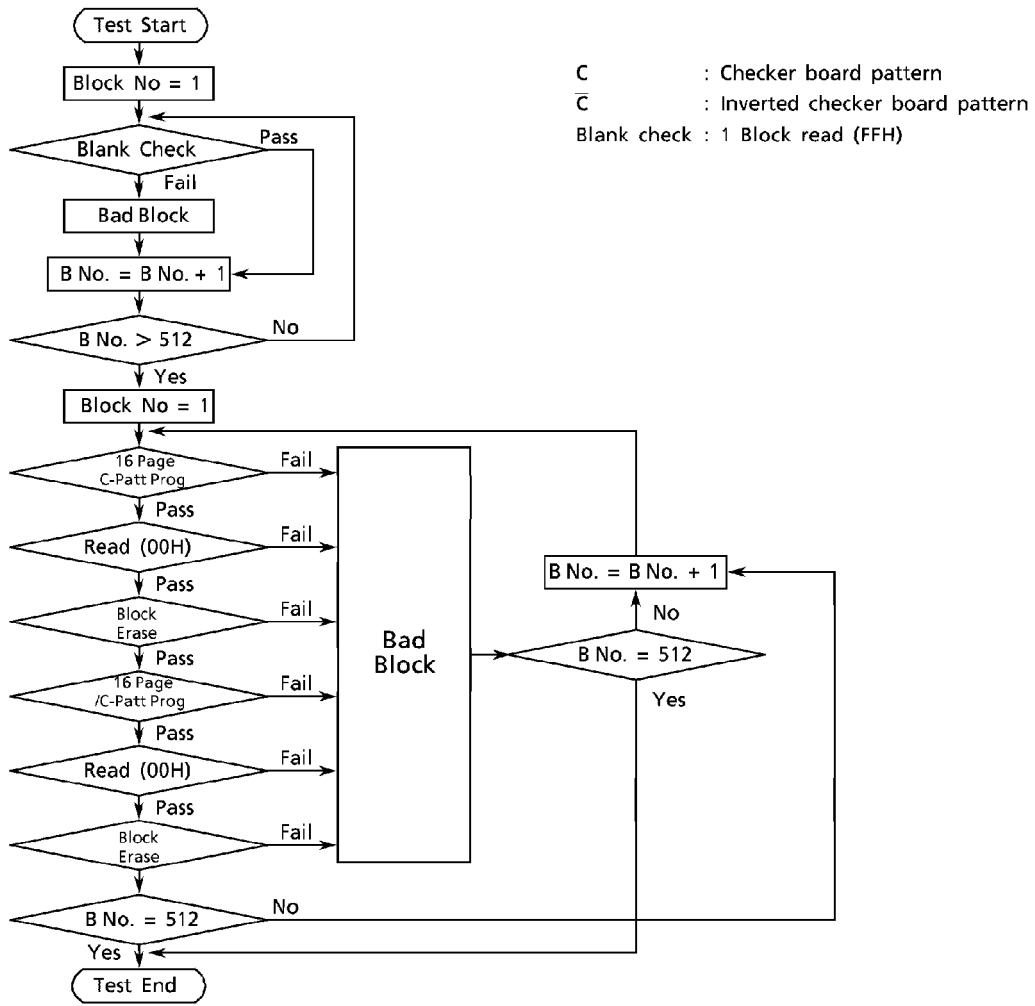

Figure 36.

PACKAGE DIMENSIONS

Plastic TSOP

TSOP II 44/40-P-400-0.80B

UNITS: mm

