



AMT8504

1.25 Gb/s Integrated 850 nm MSM-TIA
PRELIMINARY DATA SHEET - Rev 1

FEATURES

- Differential Output TIA
- 3.3V Operation
- Automatic Gain Control
- Integrated 850nm MSM detector & TIA
- 100 μ m Detector Diameter
- TO-46 Ultra Flat Window or Lens Hermetic Package
- High Reliability
- -5 to +80°C Operating Temperature Range

APPLICATIONS

- Gigabit Ethernet (1.250Gb/s)
- Fibre Channel (1.0625 Gb/s)

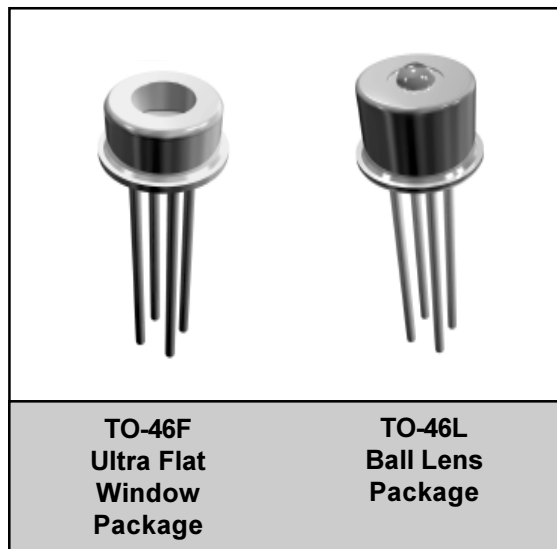

PRODUCT DESCRIPTION

The ANADIGICS AMT8504 is a 3.3V monolithically integrated Metal-Semiconductor-Metal (MSM) photodetector and transimpedance amplifier (TIA) used to convert an 850nm input optical signal into a differential output voltage, and is manufactured in ANADIGICS' 6" GaAs wafer fabrication facility. The integrated MSM and TIA receiver maximizes the receiver performance by minimizing the photodetector input parasitics to the TIA and

internally biasing the photodetector to achieve high sensitivity, bandwidth and overload performance. As an integrated product the reliability is inherently better than a discrete solution, and both the MSM-TIA integrated circuit and TO46 flat window and TO46 lens packaged receiver pass stringent reliability requirements. These products are readily designed into receivers and transceivers for Gigabit Ethernet and Fibre Channel applications.

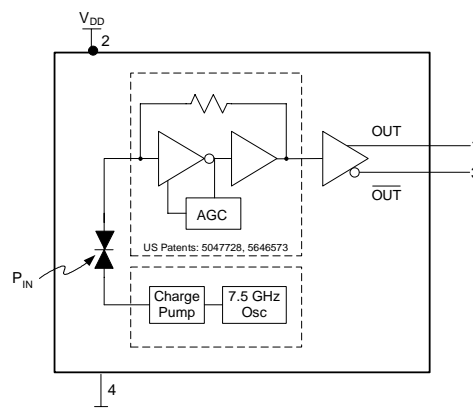

Figure 1: Equivalent Circuit

AMT8504

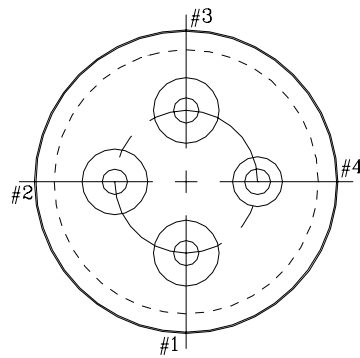

Figure 2: Pin Outline (Bottom View)

Table 1: Package Pin Description

PIN	DESCRIPTION	COMMENT
1	V_{OUT} - TIA Output Voltage (Non-inverted)	Logical '1' with optical input
2	V_{DD} - Positive Supply Voltage	+3.3 Volts
3	V_{OUT} - TIA Output Voltage (Inverted)	Logical '0' with optical input
4	Ground	Case is grounded

ELECTRICAL CHARACTERISTICS

Table 2: Absolute Maximum Ratings

V_{DD}	6.0 v
P_{IN}	+ 5 dBm
T_S	Storage Temp. - 65 °C to 125°C

Stresses in excess of the absolute ratings may cause permanent damage. Functional operation is not implied under these conditions. Exposure to absolute ratings for extended periods of time may adversely affect reliability.

Table 3: Electrical Characteristics

PARAMETER	MIN	TYP	MAX	UNIT
Wavelength (λ)	770	850	860	nm
Detector Diameter	-	100	-	μm
Small Signal Differential Responsivity ⁽¹⁾ (@ 50 MHz)	1000	-	-	V / W
Bandwidth ⁽¹⁾	900	-	-	MHz
Low Frequency Cutoff	-	-	300	kHz
Output Resistance	-	40	-	Ohm
Optical Overload ⁽²⁾	0	-	-	dBm
Optical Sensitivity ⁽²⁾	-20	- 22	-	dBm
Differential Output Voltage ⁽³⁾	-	1000	-	mV
T_{RISE} & T_{FALL} (20 - 80%) ⁽³⁾	-	260	-	ps
Duty Cycle Distortion ⁽³⁾	-	4	10	%
Total Jitter (pk-pk) ^{(3), (4)}	-	80	120	ps
Supply Current	-	-	55	mA
Operating Voltage Range	+ 3.0	+3.3	+3.6	V
Operating Case Temperature Range	-5	-	80	°C

Notes:

- (1) Measured at -14 dBm optical input power with output connected into $R_L = 100\Omega$ (differential)
- (2) Measured at 10^{-10} BER with a 2^7-1 PRBS at 1.25 GB/s
- (3) Measured with a 2^7-1 PRBS at 1.25Gb/s, an input optical power of -3dBm and $R_L=100\Omega$ (differential)
- (4) 6σ about the center eye crossing.

AMT8504

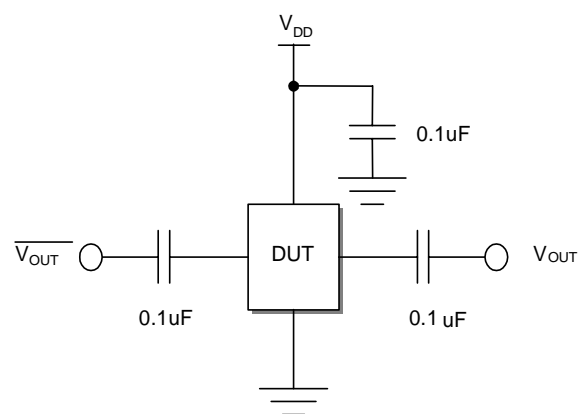

Figure 3: DUT Test Fixture Schematic

PERFORMANCE DATA

Figure 4: Eye Diagram with an Optical Input Power of -17dBm

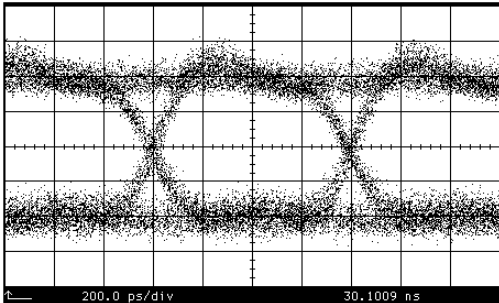

Figure 5: Eye Diagram with an Optical Input Power of 0dBm

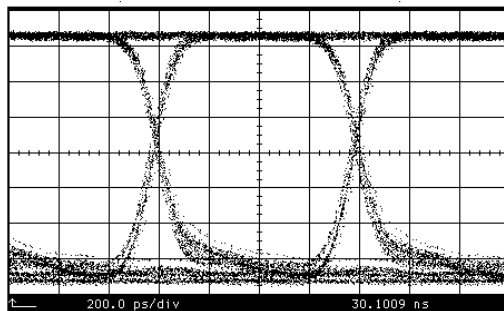

Figure 6: Supply Current vs. Temperature

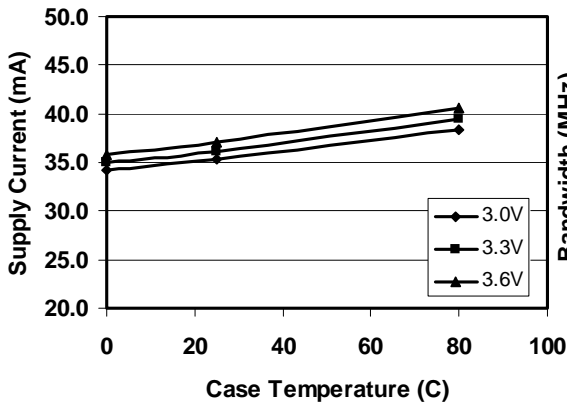

Figure 7: Bandwidth vs. Temperature

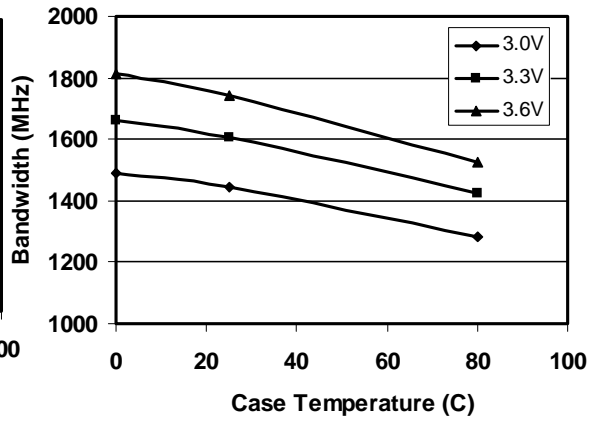

Figure 8: Differential Responsivity vs. Temperature

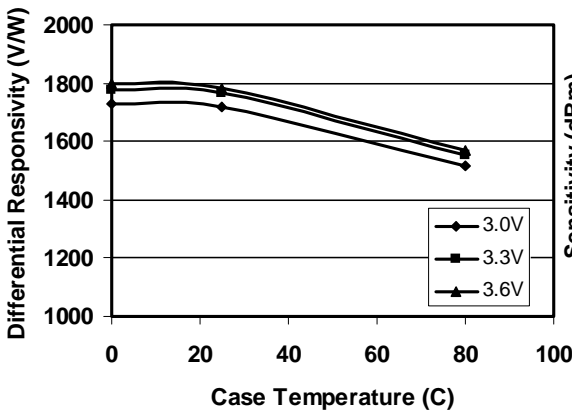
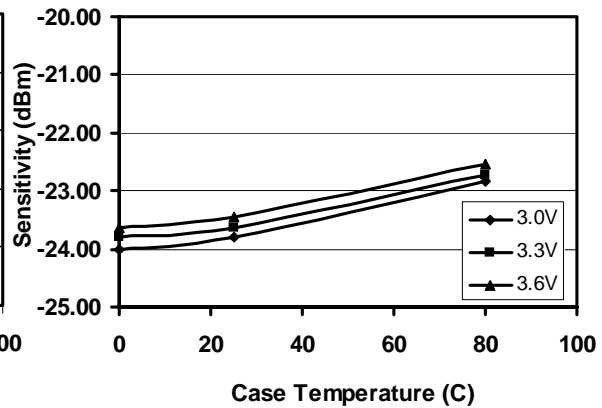

Figure 9: Sensitivity vs. Temperature



MEASUREMENT METHODS

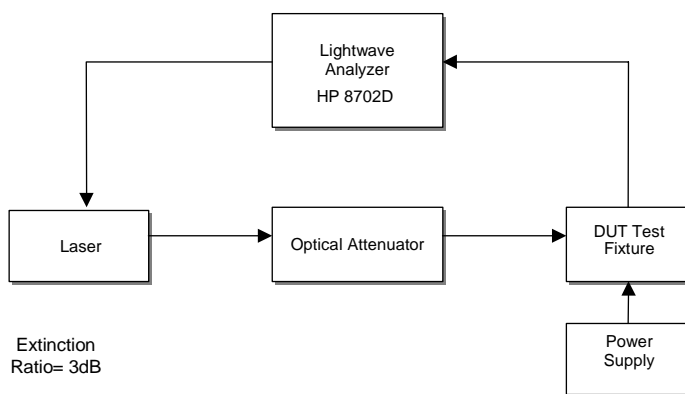

Figure 10: Test Setup for Frequency Response

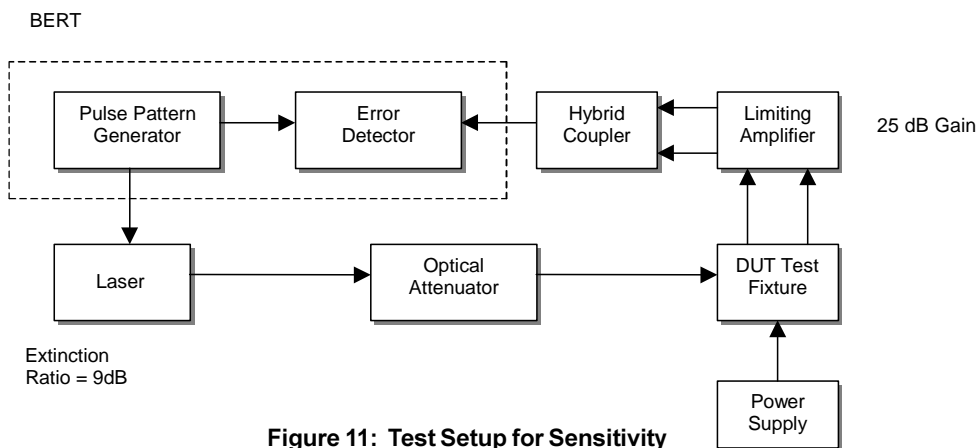

Figure 11: Test Setup for Sensitivity

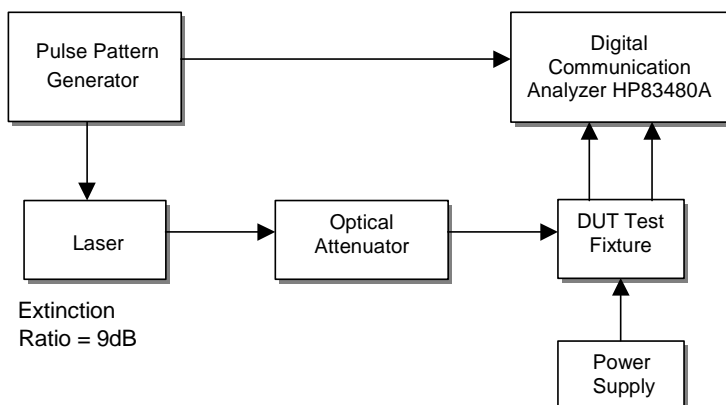

Figure 12: Test Setup for Eye Measurements

APPLICATION INFORMATION

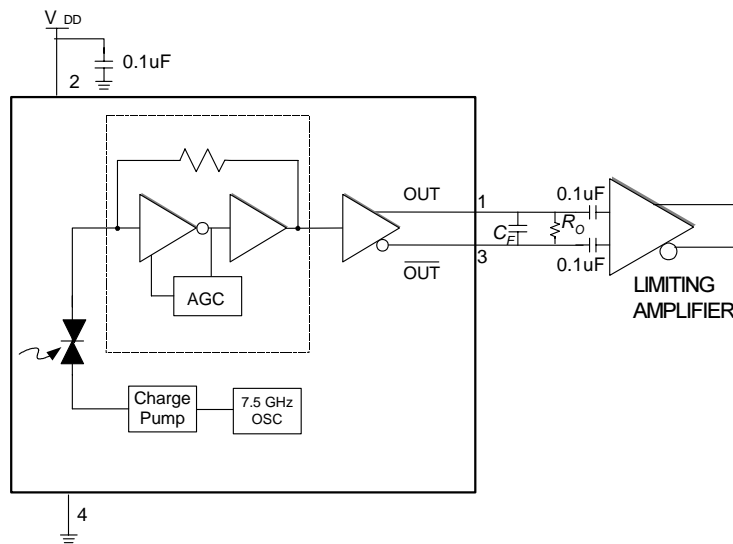

Figure 13: Application Schematic

C_F is an optional single pole noise capacitor

$$C_F = \frac{1}{2\pi f_c R}$$

f_c is the desired cutoff frequency

$$R = 50 \Omega$$

R_o is required with high input resistance limiting amplifiers

$$R_o = 100 \Omega$$

AMT8504

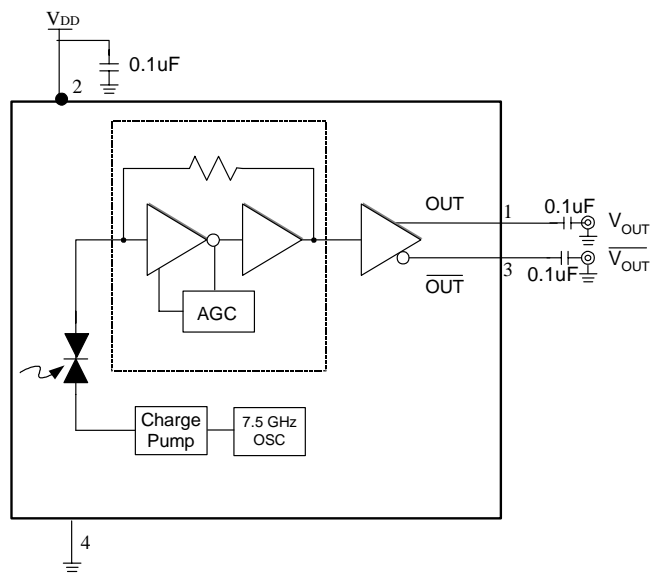

Figure 14: Evaluation Board Schematic

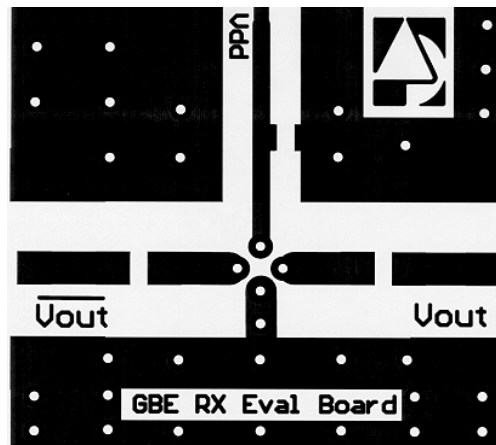
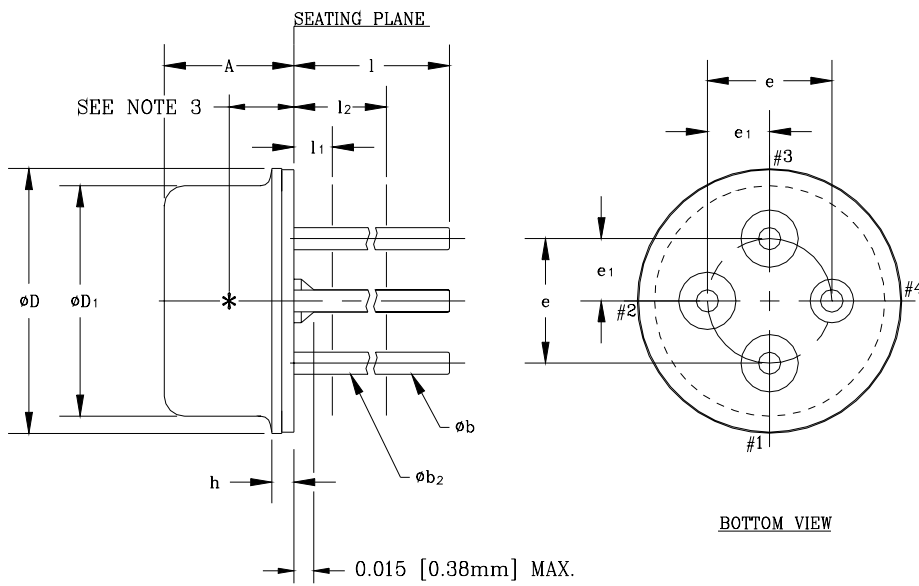

Figure 15: Evaluation Board Layout

PACKAGE OUTLINE



MM CONTROLLING DIMENSIONS

SYMBOL	INCHES		MILLIMETERS		NOTE
	MIN.	MAX.	MIN.	MAX.	
A	0.098	0.110	2.50	2.80	
øb	0.016	0.020	0.41	0.51	1
øb2	0.012	0.019	0.30	0.48	1
øD	0.212	0.218	5.38	5.54	
øD1	0.181	0.187	4.60	4.75	
e	0.100 T.P.		2.54 T.P.		2
e1	0.050 T.P.		1.27 T.P.		2
h	0.014	0.022	0.36	0.56	
l	0.500	0.540	12.70	13.70	1
l1	-	0.050	-	1.27	1
l2	0.250	-	6.35	-	1

NOTES:

- (FOUR LEADS) øb2 APPLIES BETWEEN l1 AND l2. øb APPLIES BETWEEN l2 AND 0.5 [12.70mm] FROM SEATING PLANE. DIAMETER IS UNCONTROLLED IN l1 AND BEYOND 0.5 [12.70mm] TO END OF PIN.
- MAXIMUM DIAMETER LEADS AT A GAGING PLANE 0.054 [1.37mm]+0.001 [0.025mm] -0.000 [0.000mm] BELOW SEATING PLANE TO BE WITHIN 0.007 [0.178mm] OF THEIR TRUE POSITION RELATIVE TO MAXIMUM-WIDTH TAB AND TO THE MAXIMUM 0.212 [5.40mm] DIAMETER MEASURED WITH A SUITABLE GAGE. WHEN GAGE IS NOT USED, MEASUREMENT WILL BE MADE AT 0.250 [6.35mm] FROM SEATING PLANE.
- INTERNAL OPTICAL HEIGHT = 0.052±0.003[1.31±.08]
- BENT LEADS SHOULD NOT EXTEND OUTSIDE DIAMETER (øD) OF CAP OR TOUCH EACH OTHER.
- ALL DIMENSIONS ARE REFERENCE ONLY—EXCEPT A, D & h.
- DETECTOR DIODE PLACEMENT ACCURACY: Φ 0.15MM[0.006] WITH RESPECT TO CENTER OF HEADER.(REF.ONLY)

Figure 16: T46F Package Outline Diagram

AMT8504

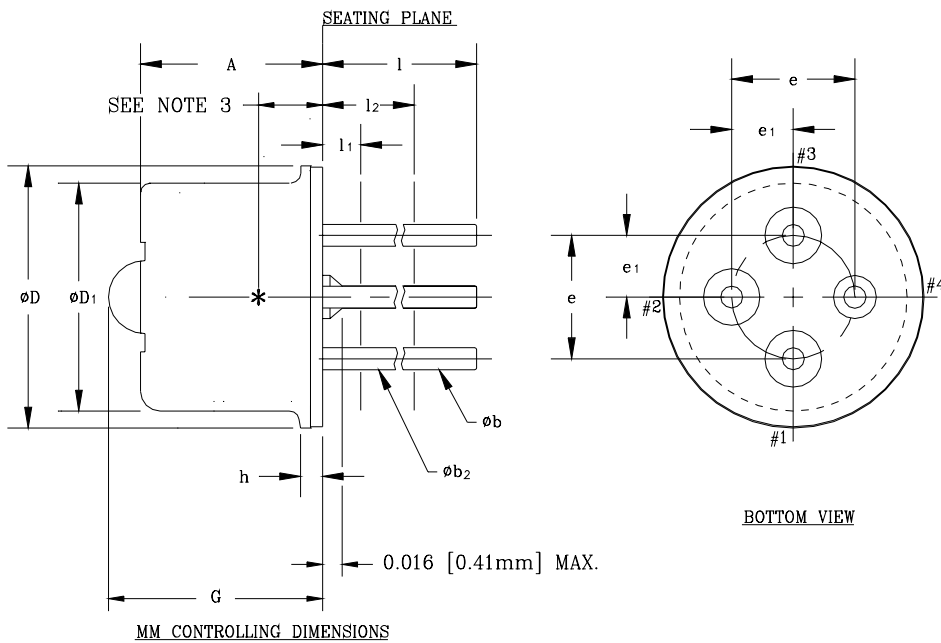

S _W _{BOL}	INCHES		MILLIMETERS		NOTE
	MIN.	MAX.	MIN.	MAX.	
A	--	0.160	--	4.00	
phi b	0.016	0.020	0.41	0.51	1
phi b2	0.012	0.019	0.30	0.48	1
phi D	0.212	0.218	5.38	5.54	
phi D1	0.181	0.187	4.60	4.75	
e	0.100 T.P.		2.54 T.P.		2
e1	0.050 T.P.		1.27 T.P.		2
h	0.014	0.022	0.36	0.56	
l	0.500	0.540	12.70	13.70	1
l1	--	0.050	--	1.27	1
l2	0.250	--	6.35	--	1
G	--	0.190	--	4.66	7

NOTES:

- (FOUR LEADS) phi b2 APPLIES BETWEEN l1 AND l2. phi b APPLIES BETWEEN l2 AND 0.5 [12.70mm] FROM SEATING PLANE. DIAMETER IS UNCONTROLLED IN l1 AND BEYOND 0.5 [12.70mm] TO END OF PIN.
- MAXIMUM DIAMETER LEADS AT A GAGING PLANE 0.054 [1.37mm]+0.001 [0.025mm] -0.000 [0.000mm] BELOW SEATING PLANE TO BE WITHIN 0.007 [0.178mm] OF THEIR TRUE POSITION RELATIVE TO MAXIMUM-WIDTH TAB AND TO THE MAXIMUM 0.212 [5.40mm] DIAMETER MEASURED WITH A SUITABLE GAGE. WHEN GAGE IS NOT USED, MEASUREMENT WILL BE MADE AT 0.250 [6.35mm] FROM SEATING PLANE.
- INTERNAL OPTICAL HEIGHT = 0.052±0.003[1.32±0.08] DIE PLACEMENT ACCURACY FOR REF. ONLY.
- BENT LEADS SHOULD NOT EXTEND OUTSIDE DIAMETER (phi D) OF CAP OR TOUCH EACH OTHER.
- ALL DIMENSIONS ARE REFERENCE ONLY—EXCEPT A, D & h.
- DETECTOR DIODE PLACEMENT ACCURACY: phi ±0.15MM[0.006] ALL DIRECTIONS
- LENS HEIGHT = 0.65±0.1 [0.026±0.004]

Figure 17: T46L Package Outline Diagram

AMT8504

NOTES

AMT8504

ORDERING INFORMATION

PART NUMBER	PACKAGE OPTION	PACKAGE DESCRIPTION
AMT8504T46F	TO-46F	Ultra Flat Window
AMT8504T46L	TO-46L	Lens



ANADIGICS, Inc.
141 Mount Bethel Road
Warren, New Jersey 07059, U.S.A
Tel: +1 (908) 668-5000
Fax: +1 (908) 668-5132
<http://www.anadigics.com>
Mktg@anadigics.com

IMPORTANT NOTICE

ANADIGICS, Inc. reserves the right to make changes to its products or to discontinue any product at any time without notice. The product specifications contained in Advanced Product Information sheets and Preliminary Data Sheets are subject to change prior to a product's formal introduction. Information in Data Sheets have been carefully checked and are assumed to be reliable; however, ANADIGICS assumes no responsibilities for inaccuracies. ANADIGICS strongly urges customers to verify that the information they are using is current before placing orders.

WARNING

ANADIGICS products are not intended for use in life support appliances, devices, or systems. Use of an ANADIGICS product in any such application without written consent is prohibited.