

## DRC1745/DRC1746

### FEATURES

- 14- or 16-Bit Resolution
- 2 or 4 Arc-Minutes Accuracy
- 2VA max Mean Output Drive Capability
- Full Accuracy for dc to 2.6kHz Reference
- Full Accuracy with dc or Pulsating Power Supplies (PPS)
- Guaranteed Operation With 3V dc Pedestal on PPS
- Can Drive Pure Inductive, Resistive or Highly Capacitive Loads
- LS or CMOS Latched Inputs With Separate High/Low Byte Enable
- Low Radius Vector Variation (0.03%)
- Optional TransZorb™ Protection Against Inductive Spikes on Output
- Protected Against +200% Overvoltage on Analog Input
- Remote Output Sensing Facility
- No Trims or External Adjustments
- Full Output Short Circuit Protection
- Single 40-Pin Package
- Hi Rel, MIL-STD 883B Versions Available

### APPLICATIONS

- Driving Synchro and Resolver Control Transformers
- Avionic Equipment (e.g., Air Data Computers)
- Interfacing With Servo Systems
- Fire Control System Outputs
- Naval Retransmission Unit Outputs
- Outputs to Radars and Navigational Aids
- Aircraft and Naval Simulators

### GENERAL DESCRIPTION

The DRC1745 and DRC1746 are hybrid packaged Digital-to-Resolver converters. They accept a 14-bit or 16-bit digital input word representing angle and output sine and cosine voltages multiplied by an analog input. The converters maintain full accuracy when the analog input frequency is in the range dc to 2.6kHz.

The units have internal power amplifiers capable of driving a 2VA load which can be pure inductive, resistive or highly capacitive. The output is fully short-circuit protected against overcurrent. The output of the converter can be used to drive directly into resolver control transformers or in conjunction with an external transformer module to drive synchro control transformers. The power available is more than adequate to drive all standard synchro control transformers.

The separately powered output stage is compatible with conventional  $\pm 15V$  dc power supplies or pulsating power supplies with pedestal components as low as 3V dc.

TransZorb is a registered trademark of General Semiconductor Industries, Inc.

### FUNCTIONAL BLOCK DIAGRAM

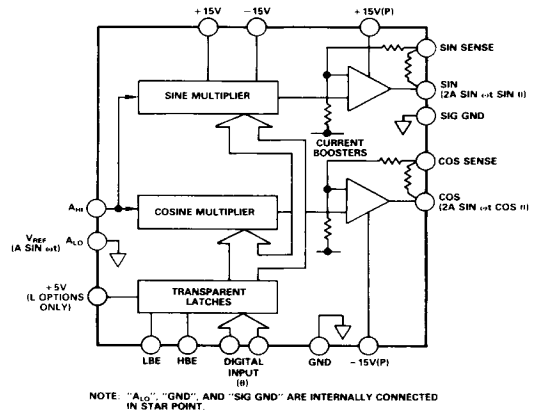

The use of pulsating power supplies greatly reduces the internal power dissipation in the hybrid package which in turn maximizes the converter's Mean Time Between Failures (MTBF).

A particular feature of the converters is that they have a remote sensing facility which means that output accuracy can be maintained even when long lines have to be driven.

The converter's data inputs are latched and the latches can be CMOS or Low Power Schottky (LS). The former gives advantages in terms of power dissipation and the latter in terms of glitch performance when used in fast dynamic update modes. The latches are transparent and have a separate high and low byte enable.

As an option, the output stage can be fitted with internal TransZorb™ protection. This gives full protection against transient voltages generated by an inductive load in response to an abrupt change in load current. This condition can occur at switch off or as a consequence of external power supply fault conditions.

The units are packaged in 40-pin dual in line hybrid packages and require no external trims or adjustments.

### MODELS AVAILABLE

The DRC1745 (14-bit resolution) and DRC1746 (16-bit resolution) are available with accuracies of  $\pm 2$  or  $\pm 4$  arc-minutes. Both units have optional TransZorb protection and a choice of either LS or CMOS inputs (see Ordering Information).

Two sets of reference and output transformers are available. The STM1660/STM1663 operates over 47Hz to 440Hz while the STM1680/STM1683 operates over 360Hz to 2.6kHz. The transformers can be Scott T connected to provide a synchro output format.

# DRC1745/DRC1746 — SPECIFICATIONS (typical @ +25°C and ±15V power supplies, unless otherwise noted)

Models	DRC1745	DRC1746
DIGITAL INPUT RESOLUTION	14 Bits (1.32 arc-minutes)	16 Bits (0.33 arc-minutes)
DIGITAL INPUT FORMAT	Parallel natural binary, TTL compatible. Includes internal 27k $\Omega$ pull-up resistors.	*
RECOMMENDED ANALOG INPUT (V <sub>REF</sub> ) <sup>1</sup>	3.4V rms (single ended input) 3.53V rms (max)	*
OUTPUT WITH RECOMMENDED ANALOG INPUT	6.8V rms 7.07V rms (max)	*
GAIN (V <sub>REF</sub> to V <sub>O</sub> )	2 ± 0.1%	*
GAIN TEMPERATURE COEFFICIENT	25ppm/°C (max)	*
ANALOG INPUT (V <sub>REF</sub> ) FREQUENCY RANGE	dc to 2.6kHz	*
ANALOG INPUT IMPEDANCE	10.2k $\Omega$	*
ANALOG OUTPUT IMPEDANCE	0.2m $\Omega$ max	*
OUTPUT OFFSET VOLTAGE	25mV (max)	*
OUTPUT OFFSET VOLTAGE DRIFT	50 $\mu$ V/°C (max)	*
OUTPUT DRIVE CAPABILITY	1.5VA (max mean) ± 300mA peak @ 10.6V peak	*
PHASE SHIFT (V <sub>REF</sub> to V <sub>O</sub> )	0.08°@400Hz	*
OUTPUT PROTECTION		
Overvoltage	TransZorb (optional) ± 12V standoff, ± 15V clamp	*
Overcurrent	Limit set @ 550mA peak. (Case header must be maintained @ 125°C max).	*
RESPONSE TO A STEP INPUT	20 $\mu$ s (max) to within accuracy of converter. Any size digital step input.	*
VECTOR ACCURACY		
Radius Error <sup>2</sup>	0.03%	*
Angular Error	± 2 or ± 4 arc-minutes	*
POWER SUPPLY (NO LOAD) <sup>3,4,5</sup>		
LS Latch Options		
+ 15 Volts	15mA (typ) 22mA (max)	*
- 15 Volts	15mA (typ) 22mA (max)	*
+ 15(P) Volts	20mA (typ) 34mA (max)	*
- 15(P) Volts	20mA (typ) 34mA (max)	*
+ 5 Volts	44mA (typ) 72mA (max)	*
CMOS Latch Options		
+ 15 Volts	24mA (typ) 30mA (max)	*
- 15 Volts	15mA (typ) 22mA (max)	*
+ 15(P) Volts	20mA (typ) 34mA (max)	*
- 15(P) Volts	20mA (typ) 34mA (max)	*
Additional Current (Load Dependent)		
+ 15(P) Volts	400mA Peak (max)	*
- 15(P) Volts	400mA Peak (max)	*
PULSATING POWER SUPPLY PEDESTAL	3V dc (min)	*
POWER DISSIPATION	See Power Dissipation section of this data sheet.	*
CASE TEMPERATURE RANGE <sup>6</sup>	- 55°C to + 125°C Operating - 65°C to + 150°C Storage	*
SIZE	40-Pin DIL 1.14 × 2.14 × 0.18" (29.0 × 54.4 × 4.6mm)	*
WEIGHT	0.9 oz (25 grams)	*

Model	Reference Input Transformer STM1680	Output Transformer STM1683
INPUT VOLTAGE	11.8, 26, 115V rms depending on option R <sub>HI</sub> , R <sub>LO</sub>	6.8V rms Sin, Cos
OUTPUT VOLTAGES	3.4V rms ± 1% A <sub>HI</sub> , A <sub>LO</sub>	11.8, 26, 90V rms ± 5% S1, S2, S3, (S4)
OUTPUT FORMAT	N/A	Synchro or resolver depending on option
FREQUENCY RANGE	STM1680 STM1683	360Hz-2.6kHz 360Hz-2.6kHz
INPUT IMPEDANCE	11.8V Input 26V Input 115V Input	50k $\Omega$ (min) 30k $\Omega$ (min) 800k $\Omega$ (min)
ACCURACY		
0.1VA Load	N/A	± 1.0 arc-min (max)
1.4VA Load	N/A	± 2.0 arc-min (max)
2.0VA Load	N/A	± 3.0 arc-min (max)
Temperature Coefficient	N/A	± 0.02 arc-min/°C (max)
OUTPUT IMPEDANCE		
11.8V Output	N/A	2.9 $\Omega$ (typ)
26V Output	N/A	13.6 $\Omega$ (typ)
90V Output	N/A	156 $\Omega$ (typ)
DC ISOLATION Voltage	1000V	1000V
SIZE		
STM1680	1.12 × 1.12 × 0.4" (28.5 × 28.5 × 10.2mm)	
STM1683		2.25 × 1.12 × 0.4" (57.1 × 28.5 × 10.2mm)
TEMPERATURE RANGE		
Operating	- 55°C to + 125°C	- 55°C to + 125°C
Storage	- 60°C to + 150°C	- 60°C to + 150°C
WEIGHT (max)		
STM1680	1.5 oz (42 grams)	
STM1683		2.5 oz (70 grams)

N/A means not applicable.

## NOTES

<sup>1</sup>V<sub>REF</sub> is internally clamped to ± 15V power supplies. Input current should not exceed 10mA.

<sup>2</sup>Worst case error over operating temperature range.

<sup>3</sup>The + 5 volt power supply must never go more than 0.3V below GND potential.

<sup>4</sup>Correct polarity voltages must be maintained on the ± 15V and the ± 15V(P) pins.

<sup>5</sup>Tracking of the ± 15V and ± 15V(P) supplies must be maintained.

<sup>6</sup>Adequate heat sinking must be provided to keep the case temperature less than 125°C.

\*Specifications same as DRC1745.

Specifications subject to change without notice.

## ABSOLUTE MAXIMUM INPUTS

+ 15V to GND	.....	+ 17V
- 15V to GND	.....	- 17V
+ 5V to GND	.....	+ 5.5V, - 0.3V
+ 15(P) to - 15(P)	.....	+ 40V
Digital Inputs GND	.....	+ 5.5V, - 0.3V

**THEORY OF OPERATION**

The operation of the DRC1745 and DRC1746 is illustrated in the block diagram shown in Figure 1.

The reference voltage,  $V_{REF}$ , ( $A \sin \omega t$ ) is multiplied by both  $\sin \theta$  and  $\cos \theta$  where  $\theta$  is the digital angle. The resultant outputs then pass through the current booster output stage to provide the resolver format output voltages viz:

$$2A \sin \omega t \sin \theta \quad (\text{Sine output})$$

$$\text{and} \quad 2A \sin \omega t \cos \theta \quad (\text{Cos output})$$

(Note: Converter has a gain of 2 from input to output.)

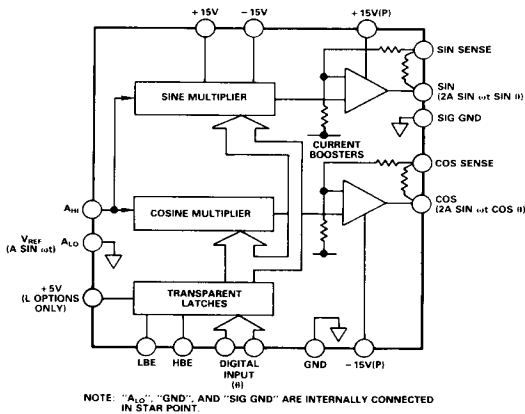

Figure 1. Theory of Operation

**CONNECTING THE CONVERTER**

The connections to the DRC1745 and DRC1746 are very straightforward.

The digital inputs should be connected to the converter using pins 1 (MSB) through 14 (LSB) in the case of the DRC1745 and through 16 (LSB) in the case of the DRC1746. The format of the digital angular input is shown under the "Bit Weight Table" section on this page.

The digital input control lines should be connected as described under the "Digital Data Input" section.

$A_{LO}$  and  $A_{HI}$  are for the analog input reference voltage ( $V_{REF}$ ). It should be noted that this is a single ended input where  $A_{LO}$  is grounded internally. If it is desired, the  $V_{REF}$  input can be externally isolated using the STM1680 or STM1660 transformer. See the section on "Output and Reference Transformers".

The converters have separate power supply inputs for the output amplifier stage (+15V(P) and -15V(P)) and for the remainder of the converter (+15V and -15V). When dc power supplies are used for the output stage, the supplies may be linked. However, when pulsating power supplies are used for the output stage, a separate dc supply must be provided for the +15V and -15V requirement. The converters have internal capacitive decoupling of 47nF on both power stage and converter supply but it is recommended that 6.8µF capacitors are taken from the +15V and -15V pin to "GND".

The "Case" pin is joined to the case which is isolated and should be connected to a convenient zero potential point in the system.

The sine and cosine outputs are taken from the "Sin" and "Cos" pins with "SIG GND" as the common connection.

The remote sense facility using "Cos Sense" and "Sin Sense" connections should be used as described under the "Remote Output Sensing" heading. If not used, the sense outputs should be connected to the corresponding Sin and Cos outputs.

**DIGITAL DATA INPUT**

The digital input to the converters is internally buffered by transparent latches. The latches will be CMOS (type 54C373) or low power Schottky (LS)(type 54LS373) depending on the option.

The "HBE" input controls the input of the most significant 8 bits and the "LBE" input controls the input of the least significant bits (6 in the case of the DRC1745 and 8 in the case of the DRC1746).

A logic "Hi" on the control lines causes the input to appear transparent and the converter output will follow the changes on the digital input. When "HBE" and "LBE" are taken to a logic "Lo" state, the converter output will be latched at the level of the data present on the input at the low going edge and remains constant until "HBE" and "LBE" are taken to a "Hi" state again. If the latches are not required, "HBE" and "LBE" can be left open circuit. The timing diagram in Figure 2 illustrates the use of "HBE" and "LBE".

Internal resistive pull-ups (to +5V using 27k resistors) are employed on all digital inputs. This ensures full TTL compatibility for either latch option even when sourcing 50µA of leakage current into each external digital driver.

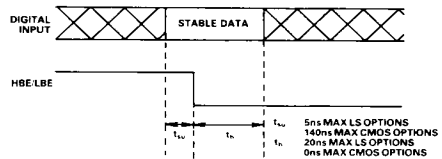

NOTE: INTERNAL LATCHES ARE: 54LS373 (LS) 54C373 (CMOS)

Figure 2. Data Transfer Diagram

**BIT WEIGHT TABLE**

Bit Number	Weight in Degrees
1 (MSB)	180.0000
2	90.0000
3	45.0000
4	22.5000
5	11.2500
6	5.6250
7	2.8125
8	1.4063
9	0.7031
10	0.3516
11	0.1758
12	0.0879
13	0.0439
14 (LSB DRC1745)	0.0220
15	0.0110
16 (LSB DRC1746)	0.0055

# DRC1745/DRC1746

## POWER DISSIPATION, PULSATING POWER SUPPLIES AND HEAT SINKING

The DRC1745 and the DRC1746 can be used with conventional dc power supplies or a pulsating power supply on the output stage (see Figure 3). The latter gives significant reductions in power dissipation within the hybrid package without any attendant loss of accuracy.

When using a pulsating power supply, full advantage can be taken of the special design which allows the power supply to have a very low dc pedestal voltage. This results in minimized power dissipation. The pedestal voltage can in fact be as low as 3 volts. The combined pedestal plus peak supply voltage must not exceed the absolute maximum rating.

Full accuracy is retained during operation on pulsating power supplies because the output stage employing these supplies is only used to provide current gain. Overall operational loop gain is independently powered. There are no special switch-on/switch-off power supply sequencing requirements, and full internal protection is provided.

The section below demonstrates the power dissipation differences for different load conditions when using dc supplies and pulsating power supplies.

### DC Power Supplies:

With inductive loads, the dc resistance is low compared with ac impedance; therefore care should be taken to ensure that no dc offset occurs at the sin and cos outputs. Note that under external current limit conditions asymmetry of the power supplies could occur, forcing a large dc offset to be present at the sin and cos outputs causing heavy power dissipation in the device. Case temperature must be maintained below 125°C.

As the reference input,  $A_{HI}$ , is directly coupled, output offset will occur if any dc component is present at this input.

When using dc power supplies, the expression for additional load dependent power dissipation is:

$$P = \frac{2 V_{dc} I_1}{\pi} (|\sin\theta| + |\cos\theta|) - \frac{V_o I_1 \cos\alpha}{2} \quad (1)$$

Where  $V_o$  is the peak output voltage.

$I_1$  is the peak value of the output load current.

$\theta$  is the digital angle.

$\alpha$  is the load phase angle.

$V_{dc}$  is the dc power supply voltage (usually  $\pm 15$  volts).

### Pulsating Power Supplies:

When using a pulsating power supply, the expression for additional load dependent power dissipation within the hybrid is:

$$P = \frac{2 V_p I_1}{\pi} (|\sin\theta| + |\cos\theta|) + \frac{V_{ac} I_1}{\pi} (\sin\alpha - \alpha \cos\alpha) \quad (2)$$

Where  $V_{ac}$  is the peak ac component of the pulsating power supply assumed equal to the peak output voltage,  $V_o$ .

$I_1$  is the peak value of the output load current.

$\theta$  is the digital angle.

$\alpha$  is the load phase angle.

$V_p$  is the dc pedestal voltage of the pulsating power supply.

Note that  $I_1 = \frac{V_o}{|Z|}$  where  $V_o$  = Peak output voltage  
 $= 2 \times V_{REF}$   
 $|Z|$  = output load

WAVEFORM MUST BE IN PHASE WITH CONVERTER REFERENCE ( $V_{REF} = A \sin \omega t$ ) CONSISTENT WITH MAINTAINING A POWER SUPPLY EXCESS OVER THE OUTPUT WAVEFORM GREATER THAN  $V_p$ .

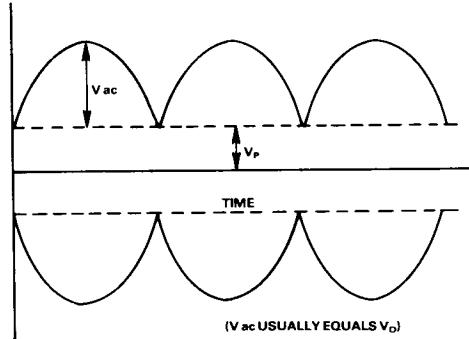

Figure 3. Pulsating Power Supply Format

### Examples of Power Dissipation:

Many factors influence the power dissipation within the hybrid. The following two examples, using typical load values and *worst case* digital angle conditions (45 degrees), illustrate the saving in power dissipation which can be achieved by using a pulsating power supply employing a low pedestal voltage.

Note that in the following examples we have chosen:

$$V_{dc} = \pm 15 \text{ volts}$$

$$V_p = 3 \text{ volts}$$

$$V_o = 9.6 \text{ volts (6.8 volts rms)}$$

$$V_{ac} = 9.6 \text{ volts (should be chosen to equal } V_o)$$

$$I_1 = 292 \text{ mA (equivalent to a 1.4VA mean load)}$$

1) DC power supply,  $\theta = 45^\circ$  resistive load.

$$P = \frac{2 \times 15 \times 0.292 (\sin 45^\circ + \cos 45^\circ) - 9.6 \times 0.292 \times 1}{2} \\ = 3.943 - 1.402 \\ = 2.54 \text{ Watts}$$

2) As example (1) but with a 3 volt pedestal pulsating power supply.

From equation (2):

$$P = \frac{2 \times 3 \times 0.292 (\sin 45^\circ + \cos 45^\circ) + 9.6 \times 0.292 \times 0}{\pi} \\ = 0.79 \text{ Watts}$$

Thus the pulsating power supply has cut down the internal dissipation by 1.75 watts, a ratio of 3.2:1.

A similar calculation using an inductive load shows a reduction from 3.94 Watts, using a dc power supply, to 1.68 Watts, when a 3 volt pedestal pulsating power supply is used. Thus the pulsating power supply has cut down the internal dissipation by 2.26 Watts, a ratio of 2.3:1.

The graph shown in Figure 4 shows the temperature at the hottest part of the base of the hybrid (in the middle of the base between "+ 15V(P)" and the opposite "N/C" pin) for resistive loads up to 2VA using dc supplies and pulsating supplies with pedestals of 3 volts and 5 volts.

Figure 5 shows a similar graph for inductive loads up to 1VA.

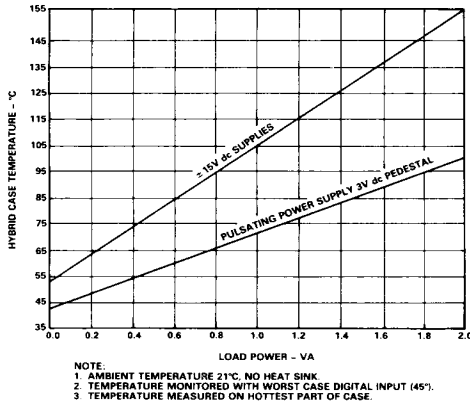

Figure 4. Case Temperature for Resistive Loads

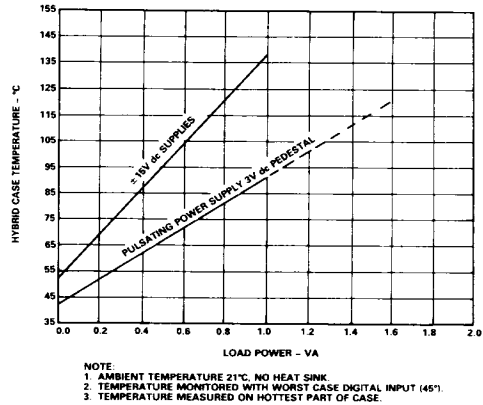

Figure 5. Case Temperature for Inductive Loads

As can be seen from Figures 4 and 5, it will be necessary to provide heat sinking when driving significant loads in order to keep the temperature of the case below its 125°C maximum.

The converters have been designed with a flat metal base to facilitate mounting on heat sinking materials. Special thermal management, utilizing direct eutectic bonding, has been employed in the output stage to minimize thermal resistance to:

**Angle**

- 0°, 90°      θ<sub>Junction/case</sub> = less than 12°C/watt
- 45°, 135°    θ<sub>Junction/case</sub> = less than 6°C/watt

Consequently the internal junction temperatures do not exceed case header temperature by more than 20°C when using pulsating power (even under worst case pure inductive load conditions). The maximum permitted junction temperature is 155°C).

**CALCULATING THE LOAD**

The following describes how to calculate the load.

In the case of synchro control transformers, first determine the value of Z<sub>so</sub>. This impedance is normally quoted by the synchro manufacturer.

The load presented by the control transformer will be:

$$\frac{3}{4} \times \frac{V^2}{|Z_{so}|}$$

where  $\sqrt{V^2}$  is the rms signal input voltage.

When the STM1683 output transformer pair is used, it is necessary to add 0.25VA to the calculated figure to allow for transformer magnetizing current. For the STM1663 output transformer a figure of 0.30VA should be added.

For example, assume that a 90V rms signal, 400Hz synchro control transformer is to be driven by the DRC1745 in conjunction with the STM1683/412 output transformer pair. (The STM1683/412 boosts the 6.8V rms signal from the DRC1745 to the 90V rms required by the control transformer.)

Z<sub>so</sub> for the control transformer is quoted as:  
 700 + j4900

Therefore

$$|Z_{so}| = \sqrt{700^2 + 4900^2} = 4950 \text{ Ohms}$$

Therefore, the load presented by the control transformer is:

$$\frac{90^2}{4950} \times \frac{3}{4} = 1.23\text{VA}$$

Adding to this value 0.25VA for the STM1683 gives a figure of 1.48VA total.

In the case of a resolver control transformer the same exercise must be performed but it is not necessary to multiply by 3/4. Some resolver manufacturers quote rms input current and in this case the load will be the product of the input current and the rms voltage used to drive it. The 0.25VA must be added if the STM1683 transformer pair is used.

**DRIVING CAPACITIVE LOADS**

Synchros and resolvers often employ capacitive tuning to minimize power dissipation. This tuning can be on the load itself or (preferably for best accuracy) on the primary of the transformer driving the load. Full tuning modifies the load to appear resistive at the reference frequency, but it appears progressively more capacitive at all frequencies above.

Since the converter is an active negative feedback device, it is essential to include a low value resistor in series with each tuning capacitor to prevent highly dissipative output stage oscillation. This resistor must not be less than 3.3Ω. A value of 5.6Ω is recommended when referred to the output of the DRC1745/ DRC1746.

The DRC1745 and DRC1746 can readily drive capacitive inputs up to 100nF at the converter output terminals without special precautions. However, please consult the factory when extreme lengths of screened cable or any other cases of high capacitance are to be driven. For example in the case of step-up transformers where the effective capacitance to be driven is:

$$C_{eff} = n^2 C_L$$

Where C<sub>L</sub> is the capacitive load.

# DRC1745/DRC1746

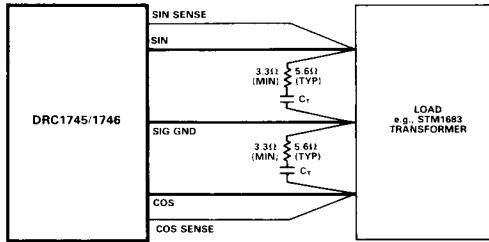

NOTE: THE REMOTE SENSE FACILITY IS SHOWN IN THE ABOVE DIAGRAM. Cr IS THE TUNING CAPACITOR.

Figure 6. Incorporating a Resistor in the Tuning Circuit

Care must be taken in tolerancing the tuning capacitors when using secondary tuning since the significant output impedance of typical output transformers can give rise to capacitive balance related angular errors.

The use of these precautions enables the converters to drive fully tuned 2VA loads.

For more information please send for relevant application note.

## SHORT CIRCUIT PROTECTION

The short circuit current limit is set at <600mA maximum.

Under short circuit or excessive current conditions, the overcurrent protection circuit will trip and reduce the output current to zero. In order to minimize power dissipated under current limit conditions the device goes into a switching mode, testing the load condition at a high frequency.

When the overload conditions are removed, the output is automatically restored to its normal condition.

## VECTOR ERRORS AND EFFECTS

The error law used in the converter has no inherent vector errors. The figure of 0.03% given in the specification is accounted for by tolerances in some of the thin-film resistor networks used in the converter.

These very low vector errors make the converters ideally suited for applications such as displays, or metal cutting control where perfect circles have to be generated.

## BANDWIDTH

The open loop gain bandwidth product of the DRC1745 and DRC1746 has been tailored to ensure that the full angular accuracy is maintained over the broadband range of dc to 2.6kHz. This results in a closed loop bandwidth of 300kHz.

## REMOTE SENSE FACILITY AND ADDITIONAL OUTPUT ERRORS

A remote sense facility is included in the DRC1745 and DRC1746 in order to reduce errors caused by the output interconnection wiring when driving large loads. The magnitude of this error is illustrated by two examples below.

Assume that the sine and cosine load impedances are perfectly matched and the sine output wiring resistance matches the cosine output wiring resistance to within 5%. Then for a resistive load of 1.4VA (33 ohms) and the worst case angle of 45 degrees, there will be 1.3 arc-minutes of extra error introduced for every 250 milliohms of resistance for the loop wiring between the converter and the load. (AWG22 = 17mΩ/ft, 1 oz PCB copper = 400mΩ/ft.)

In the case of an inductive load under similar conditions, 500 milliohms would produce the same error.

Using the remote sense facility as shown in Figure 7 will half this error or allow twice the distance to be driven for the same additional error.

If the remote sense is not used, then "COS SENSE" should be joined to "COS" and "SIN SENSE" should be joined to "SIN" at the PCB edge connector.

Note also that when output transformers are used with the converters they should be regarded as the load and the remote sense wires taken to the transformer primary inputs.

Sense wiring may employ minimum wire gauge; it does not carry load current.

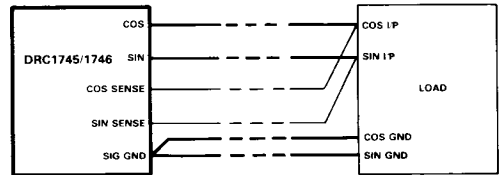

Figure 7. Using the Remote Sense Facility

The ground returns from the load should be individually wired and star-point connected at the converter's signal ground. Any common resistance in the signal returns will produce errors due to the summation of the sin and cos outputs. With a resistive load of 33 ohms at 1.4VA, and at the worst angles of 0 and 90°, there will be 1.3 arc-minutes of extra error introduced for every 12.5 milliohms of common signal return resistance.

## TRANSZORB™ OUTPUT PROTECTION

As an option, the output stages of the converter can be internally fitted with TransZorb protection. This form of protection can be advantageous and significantly increase the Mean Time Between Failures when driving inductive loads. The TransZorbs, which are effectively back to back zener diodes, give full protection against transient voltages generated by an inductive load in response to an abrupt change in load current. Such a change can occur at switch off or as a consequence of external power supply fault conditions. The TransZorbs are rated to give protection against worst case transients corresponding to an instantaneous interruption of the converter when driving into a full 2VA pure inductive load with the converter operating at the maximum case temperature of 125°C.

Figure 8 shows a simplified diagram of the converter output stage indicating the action of the TransZorb when the 15 volt supply is interrupted.

It is important to appreciate that destructively high voltages can be generated (given by  $E = L di/dt$ ) even for modest inductive loading, under many fault conditions, since  $di/dt$  is effectively uncontrolled. Internal TransZorb protection is a better and more direct solution to the problem than employing a pair of reverse biased diodes to the output stage power supplies. This is because the transient is contained within the specific load disturbed and does not escape into the power supply wiring and hence cause possible damage to other equipments and devices. A domino effect of catastrophic failure is therefore prevented.

TransZorb is a registered trademark of General Semiconductor Industries, Inc.

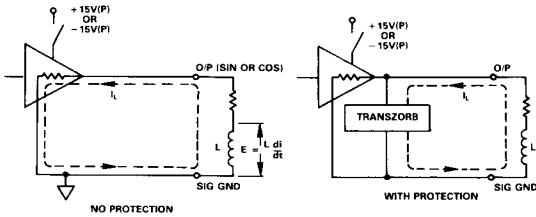

Figure 8. DRC1745/DRC1746 Output Stage Showing TransZorb Protection

Figure 9 shows the nature of transient waveforms where by the very large transient voltage generated by the inductive load is limited to a safe clamp level when it is applied to the output stage.

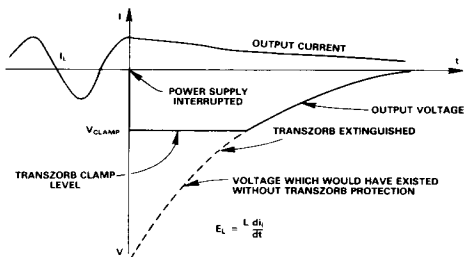

Figure 9. Transient Waveforms and TransZorb Clamping

In addition, there are conventional diode clamps on the  $\pm 15V(P)$  power supplies.

## OUTPUT AND REFERENCE TRANSFORMERS

A set of low profile (0.4" high) reference and output transformers (which are capable of handling the full drive capability of the DRC1745 and DRC1746 over a frequency range of 360Hz to 2.6kHz) are available in order to accept the standard voltage formats of synchros and resolvers.

The reference transformer, STM1680, can accept voltages of 11.8 volts, 26 volts or 115 volts depending on the option and its output is 3.4 volts rms which is suitable for connecting to  $A_{HI}$  and  $A_{LO}$  on the converter.

The output transformer pair, STM1683, accepts the 6.8 volts rms output of the converter and provides a synchro or resolver format depending on the option.

Note: For resolver option for the STM1683 transformer, part number is RTM1683.

The pin out and dimensions of the STM1680 and STM1683 are shown on the next page, and the connection to the converter in Figure 10.

Note: For operation over the frequency range 47Hz to 440Hz a similar set of transformers are available (1.0" profile height). Part numbers are STM1660 (reference transformer) and STM1663 (output transformer).

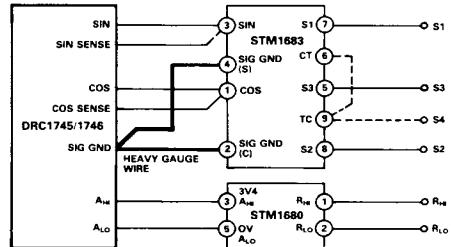

NOTE: FOR SYNCHRO OUTPUT "CT" MUST BE CONNECTED TO "TC" FOR RESOLVER OUTPUT "TC" IS S4 (NO LINK)

Figure 10. Connecting the DRC1745 to the STM1680 and STM1683 Transformers

## RESISTIVE INPUT SCALING

The analog reference input can be externally resistively scaled to cater for a wide range of voltage both when used with or without the reference transformer, STM1680/STM1660.

When the converters are used with the STM1680/STM1660 transformer, a resistance of value  $3k\Omega$  per extra volt required should be inserted in the  $A_{HI}$  line. Care should be taken to ensure that the voltage on the analog input ( $A_{HI}$ ,  $A_{LO}$ ) is 3.4 volts rms in order to provide a full scale analog output. The maximum output voltage of the converter is proportional to the input voltage (gain of 2) and therefore the resistor tolerance should be chosen so that the correct voltage appears across the  $A_{HI}$ ,  $A_{LO}$  pins. Note that the input to the reference transformer should not exceed the rated max.

Note that the best dc output offset performance is achieved when the STM1680/STM1660 transformer is used. However the use of resistive scaling can never cause an additional offset of greater than 6.5mV (max), 2.6mV (typ).

## OTHER PRODUCTS

We manufacture a wide range of hybrid and modular circuits for processing synchro and resolver information. Please ask for our comprehensive literature.

# DRC1745/DRC1746

## OUTLINE DIMENSIONS PACKAGING SPECIFICATIONS

Dimensions shown in inches and (mm).

### STM1680

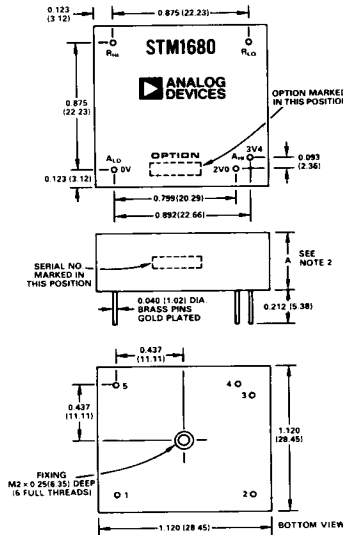

### STM1683

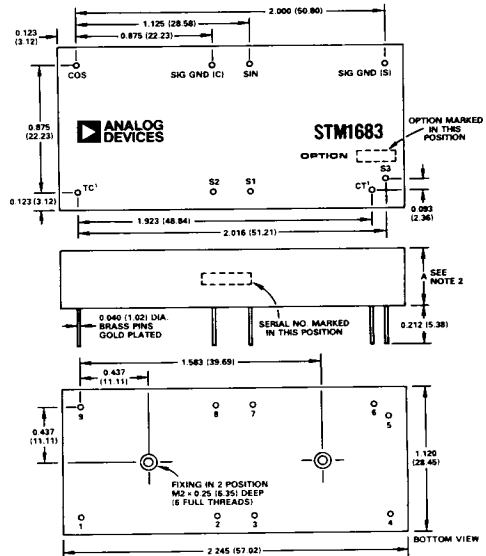

NOTES  
1. "TC" READS "S4" and "CT" READS "NC" ON RESOLVER DEVICE (RTM1683).  
2. DIMENSION "A" IS 0.4 (10.2) FOR STM1680 AND STM1683.  
THE TOLERANCES ARE +0.010", -0.005" OR +0.25mm, -0.13mm.

### DRC1745/1746

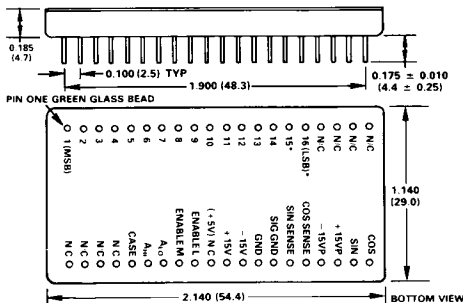

\*PINS 15 & 16 ARE NOT CONNECTED (N/C) ON DRC1745.  
PIN 31 IS "N/C" ON "C" OPTION AND "+5V" ON "L" OPTION

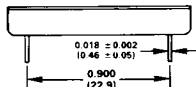

TOLERANCES = 0.005 (13)  
UNLESS OTHERWISE STATED

## ORDERING INFORMATION

