

DSP56011

Advance Information 24-BIT DVD DIGITAL SIGNAL PROCESSOR

The DSP56011 is a high-performance programmable Digital Signal Processor (DSP) developed for Digital Versatile Disc (DVD), High-Definition Television (HDTV), and Advanced Set-top audio decoding. The DSP56011 is optimized with audio-specific peripherals and customized memory configuration, and may be programmed with Motorola's certified software for Dolby AC-3 5.1 Channel Surround, Dolby Pro Logic, and MPEG1 Layer 2. These applications use Motorola's 24-bit DSP56000 architecture and are the highest quality solutions available. Flexible peripheral modules and interface software allow simple connection to a wide variety of video/system decoders. In addition, the DSP56011 offers switchable memory space configuration, a large user-definable Program ROM and two independent data RAMs and ROMs, a Serial Audio Interface (SAI), Serial Host Interface (SHI), Parallel Host Interface (HI) with Direct Memory Access (DMA) for communicating with other processors, dedicated I/O lines, on-chip Phase Lock Loop (PLL), On-Chip Emulation (OnCE™) port, and on-chip Digital Audio Transmitter (DAX). **Figure 1** shows the functional blocks of the DSP56011.

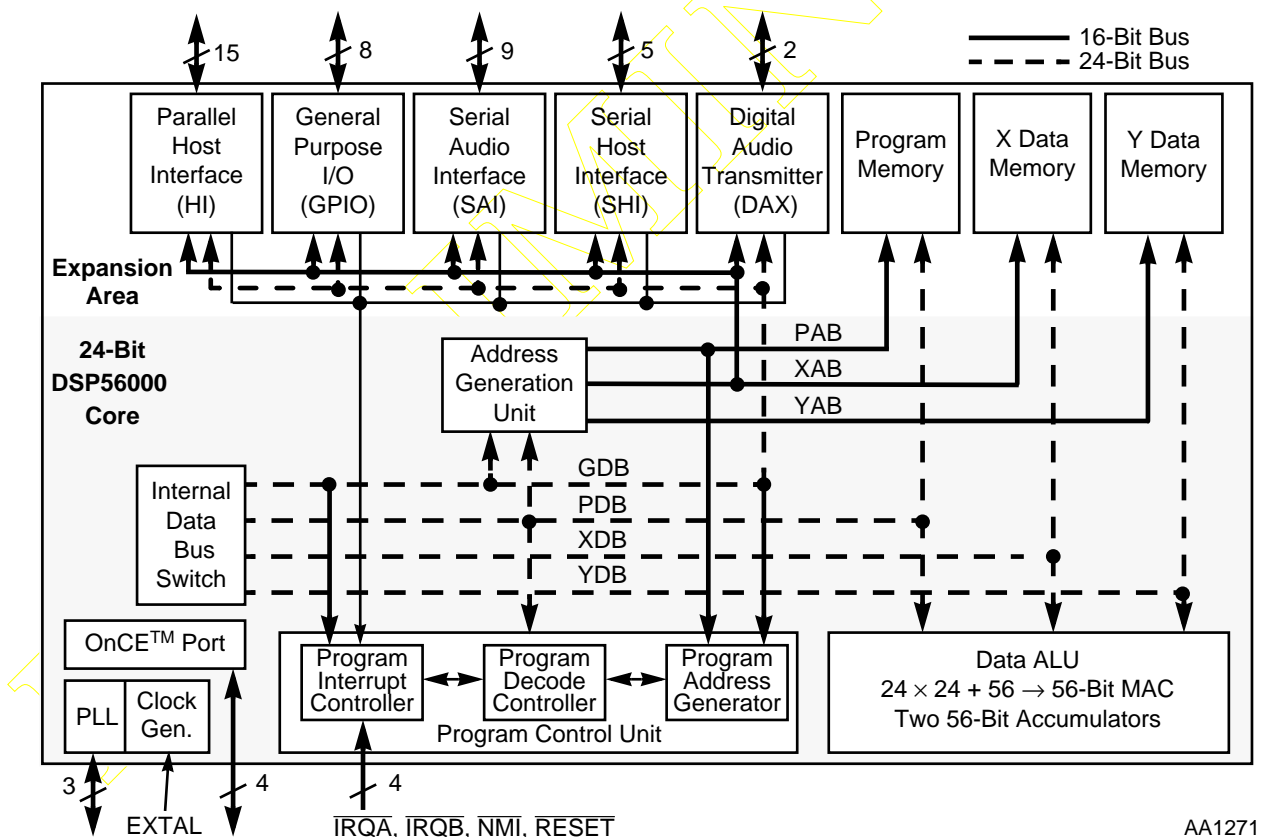

Figure 1 DSP56011 Block Diagram

This document contains information on a new product. Specifications and information herein are subject to change without notice.

Preliminary Information

TABLE OF CONTENTS

SECTION 1	SIGNAL/CONNECTION DESCRIPTIONS	1-1
SECTION 2	SPECIFICATIONS	2-1
SECTION 3	PACKAGING	3-1
SECTION 4	DESIGN CONSIDERATIONS	4-1
SECTION 5	ORDERING INFORMATION	5-1

FOR TECHNICAL ASSISTANCE:

Telephone: 1-800-521-6274

Email: dsphelp@dsp.sps.mot.com

Internet: <http://www.motorola-dsp.com>

Data Sheet Conventions

This data sheet uses the following conventions:

- OVERBAR Used to indicate a signal that is active when pulled low (For example, the RESET pin is active when low.)
- “asserted” Means that a high true (active high) signal is high or that a low true (active low) signal is low
- “deasserted” Means that a high true (active high) signal is low or that a low true (active low) signal is high

Examples:	Signal/Symbol	Logic State	Signal State	Voltage
	\overline{PIN}	True	Asserted	V_{IL}/V_{OL}
	\overline{PIN}	False	Deasserted	V_{IH}/V_{OH}
	PIN	True	Asserted	V_{IH}/V_{OH}
	PIN	False	Deasserted	V_{IL}/V_{OL}

Note: Values for V_{IL} , V_{OL} , V_{IH} , and V_{OH} are defined by individual product specifications.

Preliminary Information

FEATURES

Digital Signal Processing Core

- Efficient, object-code compatible, 24-bit DSP56000 family DSP engine
 - 47.5 Million Instructions Per Second (MIPS) with 21.05 ns instruction cycle at 95 MHz
 - Highly parallel instruction set with unique DSP addressing modes
 - Two 56-bit accumulators including extension byte
 - Parallel 24×24 -bit multiply-accumulate in 1 instruction cycle (2 clock cycles)
 - Double precision 48×48 -bit multiply with 96-bit result in 6 instruction cycles
 - 56-bit addition/subtraction in 1 instruction cycle
 - Fractional and integer arithmetic with support for multi-precision arithmetic
 - Hardware support for block-floating point Fast Fourier Transforms (FFT)
 - Hardware nested DO loops
 - Zero-overhead fast interrupts (2 instruction cycles)
 - PLL-based clocking with a wide range of frequency multiplications (1 to 4096) and power saving clock divider (2^i : $i = 0$ to 15), which reduces clock noise
 - Four 24-bit internal data buses and three 16-bit internal address buses for simultaneous accesses to one program and two data memories

Memory

- Modified Harvard architecture allows simultaneous access to program and data memories
- 12800 × 24-bit on-chip Program ROM¹
- 4096 × 24-bit on-chip X-data RAM and 3584 × 24-bit on-chip X-data ROM¹
- 4352 × 24-bit on-chip Y-data RAM and 2048 × 24-bit on-chip Y-data ROM¹
- 512 × 24-bit on-chip Program RAM and 64 × 24-bit bootstrap ROM
- As much as 2304 × 24 bits of X- and Y-data RAM can be switched to Program RAM, giving a total of 2816 × 24 bits of Program RAM

Table 1 lists the memory configurations of the DSP56011.

Table 1 DSP56011 Internal Memory Configurations

Memory Type	No Switch (PEA = 0, PEB = 0)	Switch A (PEA = 1, PEB = 0)	Switch B (PEA = 0, PEB = 1)	Switch A+B (PEA = 1, PEB = 1)
Program RAM	0.5 K	1.25 K	2.0 K	2.75 K
X data RAM	4.0 K	3.25 K	3.25 K	2.5 K
Y data RAM	4.25 K	4.25 K	3.5 K	3.5 K
Program ROM	12.5 K	12.5 K	12.5 K	12.5 K
X data ROM	3.5 K	3.5 K	3.5 K	3.5 K
Y data ROM	2.0 K	2.0 K	2.0 K	2.0 K

1. These ROMs may be factory programmed with data/program provided by the application developer.

Peripheral and Support Circuits

- SAI includes:
 - Two receivers and three transmitters
 - Master or slave capability
 - I²S, Sony, and Matshushita audio protocol implementations
 - Two sets of SAI interrupt vectors
- SHI features:
 - Single master capability
 - SPI and I²C protocols
 - 10-word receive FIFO
 - Support for 8-, 16- and 24-bit words.
- Byte-wide Parallel Host Interface with DMA support capable of reconfiguration as fifteen General Purpose Input/Output (GPIO) lines
- DAX features one serial transmitter capable of supporting S/PDIF, IEC958, CP-340, and AES/EBU formats.
- Eight dedicated, independent, programmable GPIO lines
- On-chip peripheral registers memory mapped in data memory space
- OnCE port for unobtrusive, processor speed-independent debugging
- Software programmable PLL-based frequency synthesizer for the core clock
- Power saving Wait and Stop modes
- Fully static, HCMOS design from specified operating frequency down to dc
- 100-pin plastic Thin Quad Flat Pack (TQFP) surface-mount package
- 5 V power supply

DOCUMENTATION

Table 2 lists the documents that provide a complete description of the DSP56011 and are required to design properly with the part. Documentation is available from a local Motorola distributor, a Motorola semiconductor sales office, a Motorola Literature Distribution Center, or through the Motorola DSP home page on the Internet (the source for the latest information).

Table 2 Additional DSP56011 Documentation

Document Name	Description	Order Number
DSP56000 Family Manual	Detailed description of the 56000-family architecture and the 24-bit core processor and instruction set	DSP56KFAMUM/AD
DSP56011 User's Manual	Detailed description of memory, peripherals, and interfaces	DSP56011UM/AD
DSP56011 Technical Data	Electrical and timing specifications, and pin and package descriptions	DSP56011/D



PRELIMINARY

SECTION 1

SIGNAL/CONNECTION DESCRIPTIONS

SIGNAL GROUPINGS

The input and output signals of the DSP56011 are organized into ten functional groups, as shown in **Table 1-1** and as illustrated in **Figure 1-1**.

Table 1-1 DSP56011 Functional Signal Groupings

Functional Group	Number of Signals	Detailed Description
Power (V_{CC})	13	Table 1-2
Ground (GND)	17	Table 1-3
PLL	4	Table 1-4
Interrupt and Mode Control	4	Table 1-5
Host Interface (HI) Port B	15	Table 1-6
Serial Host Interface (SHI)	5	Table 1-7
Serial Audio Interface (SAI)	9	Table 1-8 Table 1-9
General Purpose Input/Output (GPIO)	8	Table 1-10
Digital Audio Transmitter (DAX)	2	Table 1-11
OnCE Port	4	Table 1-12

Figure 1-1 is a diagram of DSP56011 signals by functional group.

Signal/Connection Descriptions

Signal Groupings

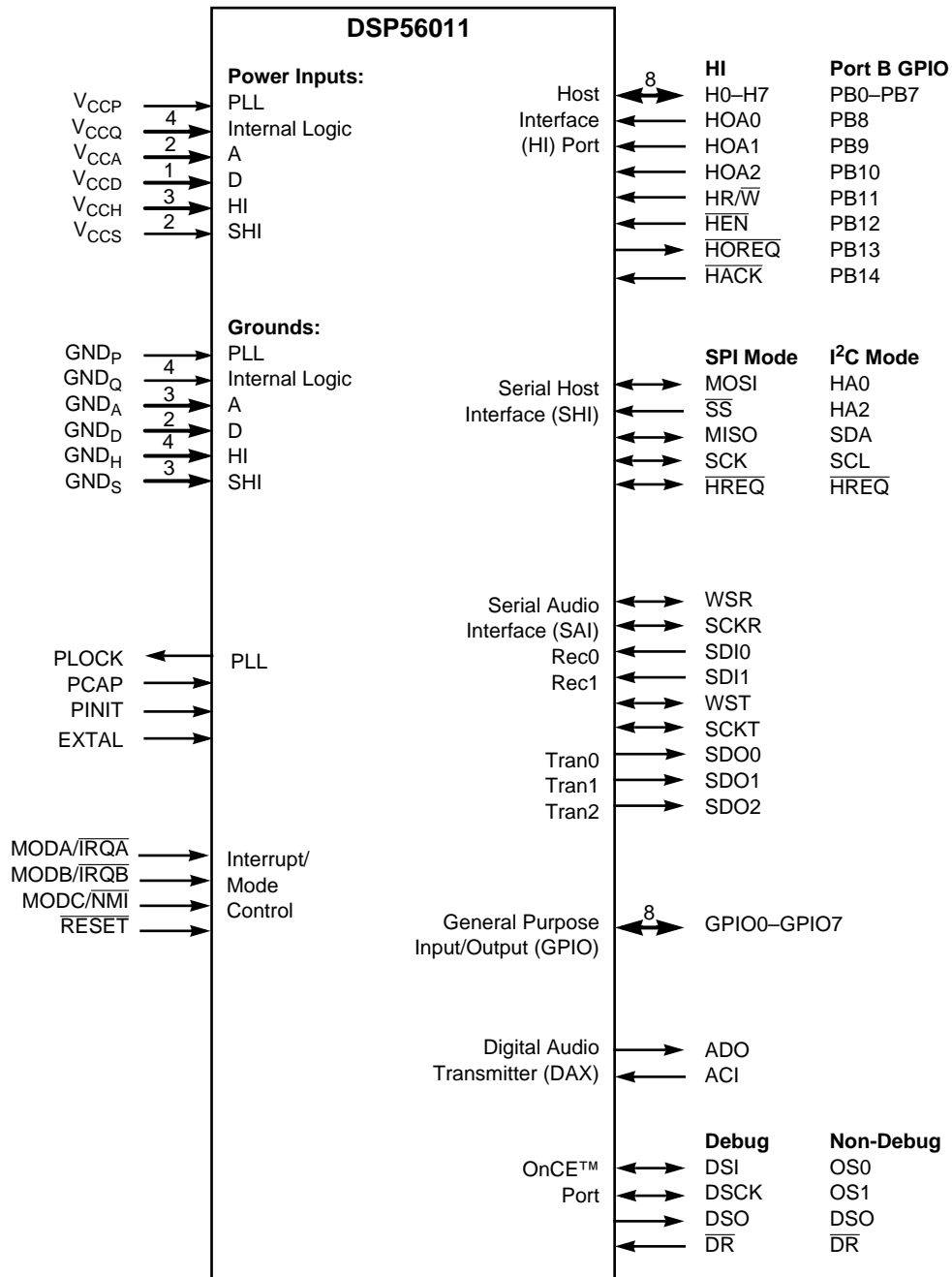

Figure 1-1 Signals Identified by Functional Group

POWER

Table 1-2 Power Inputs

Power Name	Description
V_{CCP}	PLL Power — V_{CCP} is V_{CC} dedicated for Phase Lock Loop (PLL) use. The voltage should be well-regulated and the input should be provided with an extremely low impedance path to the V_{CC} power rail. V_{CCP} should be bypassed to GND_P by a 0.1 μ F capacitor located as close as possible to the chip package.
V_{CCQ}	Quiet Power — V_{CCQ} is an isolated power for the internal processing logic. This input must be tied externally to all other chip power inputs. The user must provide adequate external decoupling capacitors.
V_{CCA}	A Power — V_{CCA} is an isolated power for sections of the internal chip logic. This input must be tied externally to all other chip power inputs. The user must provide adequate external decoupling capacitors.
V_{CCD}	D Power — V_{CCD} is an isolated power for sections of the internal chip logic. This input must be tied externally to all other chip power inputs. The user must provide adequate external decoupling capacitors.
V_{CCH}	Host Power — V_{CCH} is an isolated power for the HI I/O drivers. This input must be tied externally to all other chip power inputs. The user must provide adequate external decoupling capacitors.
V_{CCS}	Serial Host Power — V_{CCS} is an isolated power for the SHI I/O drivers. This input must be tied externally to all other chip power inputs. The user must provide adequate external decoupling capacitors.

GROUND**Table 1-3** Grounds

Ground Name	Description
GND _P	PLL Ground —GND _P is ground dedicated for PLL use. The connection should be provided with an extremely low-impedance path to ground. V _{CCP} should be bypassed to GND _P by a 0.1 μF capacitor located as close as possible to the chip package.
GND _Q	Internal Logic Ground —GND _Q is an isolated ground for the internal processing logic. This connection must be tied externally to all other chip ground connections. The user must provide adequate external decoupling capacitors.
GND _A	A Ground —GND _A is an isolated ground for sections of the internal logic. This connection must be tied externally to all other chip ground connections. The user must provide adequate external decoupling capacitors.
GND _D	D Ground —GND _D is an isolated ground for sections of the internal logic. This connection must be tied externally to all other chip ground connections. The user must provide adequate external decoupling capacitors.
GND _H	Host Ground —GND _H is an isolated ground for the HI I/O drivers. This connection must be tied externally to all other chip ground connections. The user must provide adequate external decoupling capacitors.
GND _S	Serial Host Ground —GND _S is an isolated ground for the SHI I/O drivers. This connection must be tied externally to all other chip ground connections. The user must provide adequate external decoupling capacitors.

PHASE LOCK LOOP (PLL)

Table 1-4 Phase Lock Loop Signals

Signal Name	Type	State During Reset	Signal Description
PLOCK	Output	Indeterminate	<p>Phase Locked—PLOCK is an output signal that, when driven high, indicates that the PLL has achieved phase lock. After Reset, PLOCK is driven low until lock is achieved.</p> <p>Note: PLOCK is a reliable indicator of the PLL lock state only after the chip has exited the Reset state. During hardware reset, the PLOCK state is determined by PINIT and the current PLL lock condition.</p>
PCAP	Input	Input	<p>PLL Capacitor—PCAP is an input connecting an off-chip capacitor to the PLL filter. Connect one capacitor terminal to PCAP and the other terminal to V_{CC}.</p> <p>If the PLL is not used, PCAP may be tied to V_{CC}, GND, or left floating.</p>
PINIT	Input	Input	<p>PLL Initial—During assertion of $\overline{\text{RESET}}$, the value of PINIT is written into the PLL Enable (PEN) bit of the PLL Control Register, determining whether the PLL is enabled or disabled.</p>
EXTAL	Input	Input	<p>External Clock/Crystal Input—EXTAL interfaces the internal crystal oscillator input to an external crystal or an external clock.</p>

INTERRUPT AND MODE CONTROL

Table 1-5 Interrupt and Mode Control

Signal Name	Type	State During Reset	Signal Description
MODA	Input	Input (MODA)	<p>Mode Select A—This input signal has three functions:</p> <ul style="list-style-type: none"> to work with the MODB and MODC signals to select the DSP's initial operating mode, to allow an external device to request a DSP interrupt after internal synchronization, and to turn on the internal clock generator when the DSP is in the Stop processing state, causing the DSP to resume processing. <p>MODA is read and internally latched in the DSP when the processor exits the Reset state. The logic state present on the MODA, MODB, and MODC pins selects the initial DSP operating mode. Several clock cycles after leaving the Reset state, the MODA signal changes to the external interrupt request $\overline{\text{IRQA}}$. The DSP operating mode can be changed by software after reset.</p>
$\overline{\text{IRQA}}$	Input		<p>External Interrupt Request A ($\overline{\text{IRQA}}$)—The $\overline{\text{IRQA}}$ input is a synchronized external interrupt request. It may be programmed to be level-sensitive or negative-edge triggered. When the signal is edge-triggered, triggering occurs at a voltage level and is not directly related to the fall time of the interrupt signal. However, as the fall time of the interrupt signal increases, the probability that noise on $\overline{\text{IRQA}}$ will generate multiple interrupts also increases.</p> <p>While the DSP is in the Stop mode, asserting $\overline{\text{IRQA}}$ gates on the oscillator and, after a clock stabilization delay, enables clocks to the processor and peripherals. Hardware reset causes this input to function as MODA.</p>

Table 1-5 Interrupt and Mode Control (Continued)

Signal Name	Type	State During Reset	Signal Description
MODB	Input	Input (MODB)	<p>Mode Select B—This input signal has two functions:</p> <ul style="list-style-type: none"> to work with the MODA and MODC signals to select the DSP's initial operating mode, and to allow an external device to request a DSP interrupt after internal synchronization. <p>MODB is read and internally latched in the DSP when the processor exits the Reset state. The logic state present on the MODA, MODB, and MODC pins selects the initial DSP operating mode. Several clock cycles after leaving the Reset state, the MODB signal changes to the external interrupt request $\overline{\text{IRQB}}$. The DSP operating mode can be changed by software after reset.</p>
$\overline{\text{IRQB}}$	Input		<p>External Interrupt Request B ($\overline{\text{IRQB}}$)—The $\overline{\text{IRQB}}$ input is a synchronized external interrupt request. It may be programmed to be level-sensitive or negative-edge triggered. When the signal is edge-triggered, triggering occurs at a voltage level and is not directly related to the fall time of the interrupt signal. However, as the fall time of the interrupt signal increases, the probability that noise on $\overline{\text{IRQB}}$ will generate multiple interrupts also increases. Hardware reset causes this input to function as MODB.</p>

Table 1-5 Interrupt and Mode Control (Continued)

Signal Name	Type	State During Reset	Signal Description
MODC	Input, edge-triggered	Input (MODC)	<p>Mode Select C—This input signal has two functions:</p> <ul style="list-style-type: none"> to work with the MODA and MODB signals to select the DSP's initial operating mode, and to allow an external device to request a DSP interrupt after internal synchronization. <p>MODC is read and internally latched in the DSP when the processor exits the Reset state. The logic state present on the MODA, MODB, and MODC pins selects the initial DSP operating mode. Several clock cycles after leaving the Reset state, the MODC signal changes to the Non-Maskable Interrupt request, $\overline{\text{NMI}}$. The DSP operating mode can be changed by software after reset.</p>
$\overline{\text{NMI}}$	Input, edge-triggered		<p>Non-Maskable Interrupt Request—The $\overline{\text{NMI}}$ input is a negative-edge triggered external interrupt request. This is a level 3 interrupt that can not be masked out. Triggering occurs at a voltage level and is not directly related to the fall time of the interrupt signal. However, as the fall time of the interrupt signal increases, the probability that noise on $\overline{\text{NMI}}$ will generate multiple interrupts also increases. Hardware reset causes this input to function as MODC.</p>
$\overline{\text{RESET}}$	Input	Active	<p>Reset—This input causes a direct hardware reset of the processor. When $\overline{\text{RESET}}$ is asserted, the DSP is initialized and placed in the Reset state. A Schmitt-trigger input is used for noise immunity. When the reset signal is deasserted, the initial DSP operating mode is latched from the MODA, MODB, and MODC signals. The DSP also samples the PINIT signal and writes its status into the PEN bit of the PLL Control Register. When the DSP comes out of the Reset state, deassertion occurs at a voltage level and is not directly related to the rise time of the $\overline{\text{RESET}}$ signal. However, the probability that noise on $\overline{\text{RESET}}$ will generate multiple resets increases with increasing rise time of the $\overline{\text{RESET}}$ signal.</p> <p>For proper hardware reset to occur, the clock must be active, since a number of clock ticks are required for proper propagation of the hardware Reset state.</p>

HOST INTERFACE (HI)

The HI provides a fast parallel data to 8-bit port, which may be connected directly to the host bus. The HI supports a variety of standard buses, and can be directly connected to a number of industry standard microcomputers, microprocessors, DSPs, and DMA hardware.

Table 1-6 Host Interface

Signal Name	Type	State During Reset	Signal Description
H0–H7	Input/ Output	Input	<p>Host Data Bus (H0–H7)—This data bus transfers data between the host processor and the DSP56011.</p> <p>When configured as a Host Interface port, the H0–H7 signals are tri-stated as long as $\overline{\text{HEN}}$ is deasserted. The signals are inputs unless $\overline{\text{HR}}/\overline{\text{W}}$ is high and $\overline{\text{HEN}}$ is asserted, in which case H0–H7 become outputs, allowing the host processor to read the DSP56011 data. H0–H7 become outputs when $\overline{\text{HACK}}$ is asserted during $\overline{\text{HOREQ}}$ assertion.</p>
PB0–PB7			<p>Port B GPIO 0–7 (PB0–PB7)—These signals are General Purpose I/O signals (PB0–PB7) when the Host Interface is not selected.</p> <p>After reset, the default state for these signals is GPIO input.</p>
HOA0–HOA2	Input	Input	<p>Host Address0–Host Address 2 (HOA0–HOA2)—These inputs provide the address selection for each Host Interface register.</p>
PB8–PB10	Input/ Output		<p>Port B GPIO 8–10 (PB8–PB10)—These signals are General Purpose I/O signals (PB8–PB10) when the Host Interface is not selected.</p> <p>After reset, the default state for these signals is GPIO input.</p>

Signal/Connection Descriptions

Host Interface (HI)

Table 1-6 Host Interface (Continued)

Signal Name	Type	State During Reset	Signal Description
HR/ \overline{W}	Input	Input	Host Read/Write —This input selects the direction of data transfer for each host processor access. If HR/ \overline{W} is high and \overline{HEN} is asserted, H0–H7 are outputs and DSP data is transferred to the host processor. If HR/ \overline{W} is low and \overline{HEN} is asserted, H0–H7 are inputs and host data is transferred to the DSP. HR/ \overline{W} must be stable when \overline{HEN} is asserted.
PB11	Input/ Output		Port B GPIO 11 (PB11) —This signal is a General Purpose I/O signal (PB11) when the Host Interface is not being used. After reset, the default state for this signal is GPIO input.
\overline{HEN}	Input	Input	Host Enable —This input enables a data transfer on the host data bus. When \overline{HEN} is asserted and HR/ \overline{W} is high, H0–H7 become outputs and the host processor may read DSP56011 data. When \overline{HEN} is asserted and HR/ \overline{W} is low, H0–H7 become inputs. Host data is latched inside the DSP on the rising edge of \overline{HEN} . Normally, a chip select signal derived from host address decoding and an enable strobe are used to generate \overline{HEN} .
PB12	Input/ Output		Port B GPIO 12 (PB12) —This signal is a General Purpose I/O signal (PB12) when the Host Interface is not being used. After reset, the default state for this signal is GPIO input.
\overline{HOREQ}	Open- drain Output	Input	Host Request —This signal is used by the Host Interface to request service from the host processor, DMA controller, or a simple external controller. Note: \overline{HOREQ} should always be pulled high when it is not in use.
PB13	Input/ Output		Port B GPIO 13 (PB13) —This signal is a General Purpose (not open-drain) I/O signal (PB13) when the Host Interface is not selected. After reset, the default state for this signal is GPIO input.

Preliminary Information

Table 1-6 Host Interface (Continued)

Signal Name	Type	State During Reset	Signal Description
$\overline{\text{HACK}}$	Input	Input	<p>Host Acknowledge—This input has two functions. It provides a host acknowledge handshake signal for DMA transfers and it receives a host interrupt acknowledge compatible with MC68000 Family processors.</p> <p>Note: $\overline{\text{HACK}}$ should always be pulled high when it is not in use.</p>
PB14	Input/ Output		<p>Port B GPIO 14 (PB14)—This signal is a General Purpose I/O signal (PB14) when the Host Interface is not selected.</p> <p>After reset, the default state for this signal is GPIO input.</p>

SERIAL HOST INTERFACE (SHI)

The SHI has five I/O signals that can be configured to allow the SHI to operate in either SPI or I²C mode.

Table 1-7 Serial Host Interface (SHI) Signals

Signal Name	Signal Type	State during Reset	Signal Description
SCK	Input or Output	Tri-stated	<p>SPI Serial Clock—The SCK signal is an output when the SPI is configured as a master, and a Schmitt-trigger input when the SPI is configured as a slave. When the SPI is configured as a master, the SCK signal is derived from the internal SHI clock generator. When the SPI is configured as a slave, the SCK signal is an input, and the clock signal from the external master synchronizes the data transfer. The SCK signal is ignored by the SPI if it is defined as a slave and the Slave Select (SS) signal is not asserted. In both the master and slave SPI devices, data is shifted on one edge of the SCK signal and is sampled on the opposite edge where data is stable. Edge polarity is determined by the SPI transfer protocol. The maximum allowed internally generated bit clock frequency is $f_{osc}/4$ for the SPI mode, where f_{osc} is the clock on EXTAL. The maximum allowed externally generated bit clock frequency is $f_{osc}/3$ for the SPI mode.</p>
SCL	Input or Output		<p>I²C Serial Clock—SCL carries the clock for I²C bus transactions in the I²C mode. SCL is a Schmitt-trigger input when configured as a slave, and an open-drain output when configured as a master. SCL should be connected to V_{CC} through a pull-up resistor. The maximum allowed internally generated bit clock frequency is $f_{osc}/6$ for the I²C mode where f_{osc} is the clock on EXTAL. The maximum allowed externally generated bit clock frequency is $f_{osc}/5$ for the I²C mode.</p> <p>An external pull-up resistor is not required.</p>

Table 1-7 Serial Host Interface (SHI) Signals (Continued)

Signal Name	Signal Type	State during Reset	Signal Description
MISO	Input or Output	Tri-stated	SPI Master-In-Slave-Out —When the SPI is configured as a master, MISO is the master data input line. The MISO signal is used in conjunction with the MOSI signal for transmitting and receiving serial data. This signal is a Schmitt-trigger input when configured for the SPI Master mode, an output when configured for the SPI Slave mode, and tri-stated if configured for the SPI Slave mode when \overline{SS} is deasserted. An external pull-up resistor is not required for SPI operation.
SDA	Input or open-drain Output		I²C Data and Acknowledge —In I ² C mode, SDA is a Schmitt-trigger input when receiving and an open-drain output when transmitting. SDA should be connected to V_{CC} through a pull-up resistor. SDA carries the data for I ² C transactions. The data in SDA must be stable during the high period of SCL. The data in SDA is only allowed to change when SCL is low. When the bus is free, SDA is high. The SDA line is only allowed to change during the time SCL is high in the case of start and stop events. A high to low transition of the SDA line while SCL is high is a unique situation, which is defined as the start event. A low to high transition of SDA while SCL is high is a unique situation, which is defined as the stop event.
MOSI	Input or Output	Tri-stated	SPI Master-Out-Slave-In —When the SPI is configured as a master, MOSI is the master data output line. The MOSI signal is used in conjunction with the MISO signal for transmitting and receiving serial data. MOSI is the slave data input line when the SPI is configured as a slave. This signal is a Schmitt-trigger input when configured for the SPI Slave mode.
HA0	Input		I²C Slave Address 0 —This signal uses a Schmitt-trigger input when configured for the I ² C mode. When configured for I ² C Slave mode, the HA0 signal is used to form the slave device address. HA0 is ignored when it is configured for the I ² C Master mode. An external pull-up resistor is not required.

Table 1-7 Serial Host Interface (SHI) Signals (Continued)

Signal Name	Signal Type	State during Reset	Signal Description
\overline{SS}	Input	Tri-stated	<p>SPI Slave Select—This signal is an active low Schmitt-trigger input when configured for the SPI mode. When configured for the SPI Slave mode, this signal is used to enable the SPI slave for transfer. When configured for the SPI Master mode, this signal should be kept deasserted (pulled high). If it is asserted while configured as SPI master, a bus error condition is flagged.</p>
HA2	Input		<p>I²C Slave Address 2—This signal uses a Schmitt-trigger input when configured for the I²C mode. When configured for the I²C Slave mode, the HA2 signal is used to form the slave device address. HA2 is ignored in the I²C Master mode. If \overline{SS} is deasserted, the SHI ignores SCK clocks and keeps the MISO output signal in the high-impedance state.</p> <p>This signal is tri-stated during hardware, software, or individual reset (thus, there is no need for an external pull-up in this state).</p>
\overline{HREQ}	Input or Output	Tri-stated	<p>Host Request—This signal is an active low Schmitt-trigger input when configured for the Master mode, but an active low output when configured for the Slave mode.</p> <p>When configured for the Slave mode, \overline{HREQ} is asserted to indicate that the SHI is ready for the next data word transfer and deasserted at the first clock pulse of the new data word transfer. When configured for the Master mode, \overline{HREQ} is an input and when asserted by the external slave device, it will trigger the start of the data word transfer by the master. After finishing the data word transfer, the master will await the next assertion of \overline{HREQ} to proceed to the next transfer.</p> <p>This signal is tri-stated during hardware, software, personal reset, or when the HREQ1–HREQ0 bits in the HCSR are cleared (no need for external pull-up in this state).</p>

SERIAL AUDIO INTERFACE (SAI)

The SAI is composed of separate receiver and transmitter sections.

SAI Receive Section

The receive section of the SAI has four dedicated signals.

Table 1-8 Serial Audio Interface (SAI) Receive Signals

Signal Name	Signal Type	State during Reset	Signal Description
SDI0	Input	Tri-stated	Serial Data Input 0 —This is the receiver 0 serial data input. This signal is high impedance during hardware or software reset, while receiver 0 is disabled ($R0EN = 0$), or while the chip is in the Stop state. No external pull-up resistor is required.
SDI1	Input	Tri-stated	Serial Data Input 1 —This is the receiver 1 serial data input. This signal is high impedance during hardware or software reset, while receiver 1 is disabled ($R1EN = 0$), or while the chip is in the Stop state. No external pull-up resistor is required.
SCKR	Input or Output	Tri-stated	Receive Serial Clock —SCKR is an output if the receiver section is programmed as a master, and a Schmitt-trigger input if programmed as a slave. SCKR is high impedance if all receivers are disabled (personal reset) and during hardware or software reset, or while the chip is in the Stop state. No external pull-up is necessary.
WSR	Input or Output	Tri-stated	Receive Word Select —WSR is an output if the receiver section is programmed as a master, and a Schmitt-trigger input if programmed as a slave. WSR is used to synchronize the data word and to select the left/right portion of the data sample. WSR is high impedance if all receivers are disabled (personal reset), during hardware reset, during software reset, or while the chip is in the stop state. No external pull-up is necessary.

SAI Transmit Section

The transmit section of the SAI has five dedicated signals.

Table 1-9 Serial Audio Interface (SAI) Transmit Signals

Signal Name	Signal Type	State during Reset	Signal Description
SDO0	Output	Driven high	Serial Data Output 0 —SDO0 is the transmitter 0 serial output. SDO0 is driven high if transmitter 0 is disabled, during personal reset, hardware reset and software reset, or when the chip is in the Stop state.
SDO1	Output	Driven high	Serial Data Output 1 —SDO1 is the transmitter 1 serial output. SDO1 is driven high if transmitter 1 is disabled, during personal reset, hardware reset and software reset, or when the chip is in the Stop state.
SDO2	Output	Driven high	Serial Data Output 2 —SDO2 is the transmitter 2 serial output. SDO2 is driven high if transmitter 2 is disabled, during personal reset, hardware reset and software reset, or when the chip is in the Stop state.
SCKT	Input or Output	Tri-stated	<p>Transmit Serial Clock—This signal provides the clock for the Serial Audio Interface (SAI). The SCKT signal can be an output if the transmit section is programmed as a master, or a Schmitt-trigger input if the transmit section is programmed as a slave. When the SCKT is an output, it provides an internally generated SAI transmit clock to external circuitry. When the SCKT is an input, it allows external circuitry to clock data out of the SAI.</p> <p>SCKT is tri-stated if all transmitters are disabled (personal reset), during hardware reset, software reset, or while the chip is in the Stop state. No external pull-up is necessary.</p>
WST	Input or Output	Tri-stated	<p>Transmit Word Select—WST is an output if the transmit section is programmed as a master, and a Schmitt-trigger input if programmed as a slave. WST is used to synchronize the data word and select the left/right portion of the data sample.</p> <p>WST is tri-stated if all transmitters are disabled (personal reset), during hardware or software reset, or while the chip is in the Stop state. No external pull-up is necessary.</p>

GENERAL PURPOSE INPUT/OUTPUT (GPIO)

Table 1-10 General Purpose I/O (GPIO) Signals

Signal Name	Signal Type	State during Reset	Signal Description
GPIO0–GPIO7	Input or Output (standard or open-drain)	Disconnected internally	<p>General Purpose Input/Output—These signals are used for control and handshake functions between the DSP and external circuitry. Each GPIO signal may be individually programmed to be one of four states:</p> <ul style="list-style-type: none"> • Not connected • Input • Standard output • Open-drain output

DIGITAL AUDIO INTERFACE (DAX)

Table 1-11 Digital Audio Interface (DAX) Signals

Signal Name	Type	State During Reset	Signal Description
ADO	Output	Output, driven high	<p>Digital Audio Data Output—This signal is an audio and non-audio output in the form of AES/EBU, CP340 and IEC958 data in a biphasic mark format. The signal is driven high when the DAX is disabled, and during hardware or software reset.</p>
ACI	Input	Tri-stated	<p>Audio Clock Input—This is the DAX clock input. When programmed to use an external clock, this input supplies the DAX clock. The external clock frequency must 256, 384, or 512 times the audio sampling frequency (256 x Fs, 384 x Fs or 512 x Fs, respectively). The ACI signal is high impedance (tri-stated) only during hardware or software reset. If the DAX is not used, connect the ACI signal to ground through an external pull-down resistor to ensure a stable logic level at the input.</p>

OnCE PORT

Table 1-12 On-Chip Emulation Port (OnCE) Signals

Signal Name	Signal Type	State during Reset	Signal Description
DSI	Input	Low Output	Debug Serial Input —In Debug mode, serial data or commands are provided as inputs to the OnCE controller via the DSI signal. Data is latched on the falling edge of the DSCK serial clock. Data is always shifted into the OnCE serial port Most Significant Bit (MSB) first. When switching from output to input, the signal is tri-stated.
OS0	Output		Chip Status 0 —When the chip is not in Debug mode, this signal is an output that works with the OS1 signal to provide information about the chip status. Note: If the OnCE interface is in use, an external pull-down resistor should be attached to this pin. If the OnCE interface is not in use, the resistor is not required.
DSCK	Input	Low Output	Debug Serial Clock —The DSCK signal is used in Debug mode and supplies the serial input clock to the OnCE module to shift data into and out of the OnCE serial port. (Data is clocked into the OnCE port on the falling edge and is clocked out of the OnCE serial port on the rising edge.) The debug serial clock frequency must be no greater than $\frac{1}{8}$ of the processor clock frequency. When switching from input to output, the signal is tri-stated.
OS1	Output		Chip Status 1 —When the chip is not in Debug mode, this signal is an output that works with the OS0 signal to provide information about the chip status. Note: If the OnCE interface is in use, an external pull-down resistor should be attached to this pin. If the OnCE interface is not in use, the resistor is not required.

Table 1-12 On-Chip Emulation Port (OnCE) Signals (Continued)

Signal Name	Signal Type	State during Reset	Signal Description
DSO	Output	Pulled high	<p>Debug Serial Output—Data contained in one of the OnCE controller registers is provided through the DSO output signal, as specified by the last command received from the external command controller. Data is always shifted out the OnCE serial port MSB first. Data is clocked out of the OnCE serial port on the rising edge of DSCK.</p> <p>The DSO signal also provides acknowledge pulses to the external command controller. When the chip enters the Debug mode, the DSO signal will be pulsed low to indicate (acknowledge) that the OnCE is waiting for commands. After the OnCE receives a read command, the DSO signal is pulsed low to indicate that the requested data is available and the OnCE serial port is ready to receive clocks in order to deliver the data. After the OnCE receives a write command, the DSO signal is pulsed low to indicate that the OnCE serial port is ready to receive the data to be written; after the data is written, another acknowledge pulse is provided.</p>
\overline{DR}	Input	Input	<p>Debug Request—A Debug Request (\overline{DR}) input from an external command controller allows the user to enter the Debug mode of operation. When \overline{DR} is asserted, it causes the DSP to finish the current instruction being executed, save the instruction pipeline information, enter the Debug mode, and wait for commands to be entered from the DSI line. While in Debug mode, the \overline{DR} signal lets the user reset the OnCE controller by asserting it and deasserting it after receiving an acknowledge signal.</p> <p>Note: It may be necessary to reset the OnCE controller in cases where synchronization between the OnCE controller and external circuitry is lost.</p> <p>\overline{DR} must be deasserted after the OnCE responds with an acknowledge on the DSO signal and before sending the first OnCE command. Asserting \overline{DR} causes the chip to exit the Stop or Wait state. Having \overline{DR} asserted during the deassertion of \overline{RESET} causes the DSP to enter Debug mode.</p> <p>Note: If the OnCE interface is not in use, attach an external pull-up resistor to the \overline{DR} input.</p>

Preliminary Information



PRELIMINARY

Preliminary Information

SECTION 2

SPECIFICATIONS

INTRODUCTION

The DSP56011 is fabricated in high density CMOS with Transistor-Transistor Logic (TTL) compatible inputs and outputs. The DSP56011 specifications are preliminary and are from design simulations, and may not be fully tested or guaranteed at this early stage of the product life cycle. For design convenience, timings for 81 MHz and 95 MHz operation are included. Finalized specifications will be published after full characterization and device qualifications are complete.

MAXIMUM RATINGS

CAUTION

This device contains circuitry protecting against damage due to high static voltage or electrical fields; however, normal precautions should be taken to avoid exceeding maximum voltage ratings. Reliability is enhanced if unused inputs are tied to an appropriate logic voltage level (e.g., either GND or V_{CC}).

Note: In the calculation of timing requirements, adding a maximum value of one specification to a minimum value of another specification does not yield a reasonable sum. A maximum specification is calculated using a worst case variation of process parameter values in one direction. The minimum specification is calculated using the worst case for the same parameters in the opposite direction. Therefore, a "maximum" value for a specification will never occur in the same device that has a "minimum" value for another specification; adding a maximum to a minimum represents a condition that can never exist.

Preliminary Information

Specifications

Thermal characteristics

Table 2-1 Maximum Ratings

Rating ¹	Symbol	Value ^{1, 2}	Unit
Supply Voltage	V_{CC}	-0.3 to +7.0	V
All input voltages	V_{IN}	GND - 0.5 to $V_{CC} + 0.5$	V
Current drain per pin excluding V_{CC} and GND	I	10	mA
Operating temperature range	T_J	-40 to +105	°C
Storage temperature	T_{STG}	-55 to +125	°C
Notes: 1. GND = 0 V, $V_{CC} = 5.0 \text{ V} \pm 5\%$, $T_J = -40^\circ\text{C}$ to $+105^\circ\text{C}$, CL = 50 pF + 2 TTL Loads 2. Absolute maximum ratings are stress ratings only, and functional operation at the maximum is not guaranteed. Stress beyond the maximum rating may affect device reliability or cause permanent damage to the device.			

THERMAL CHARACTERISTICS

Table 2-2 Thermal Characteristics

Characteristic	Symbol	TQFP Value	Unit
Junction-to-ambient thermal resistance ¹	$R_{\theta JA}$ or θ_{JA}	47	°C/W
Junction-to-case thermal resistance ²	$R_{\theta JC}$ or θ_{JC}	5.8	°C/W
Thermal characterization parameter	Ψ_{JT}	1.6	°C/W
Notes: 1. Junction-to-ambient thermal resistance is based on measurements on a horizontal-single-sided printed circuit board per SEMI G38-87 in natural convection. (SEMI is Semiconductor Equipment and Materials International, 805 East Middlefield Rd., Mountain View, CA 94043, (415) 964-5111) Measurements were done with parts mounted on thermal test boards conforming to specification EIA/JESD51-3. 2. Junction-to-case thermal resistance is based on measurements using a cold plate per SEMI G30-88, with the exception that the cold plate temperature is used for the case temperature.			

Preliminary Information

DC ELECTRICAL CHARACTERISTICS

Table 2-3 DC Electrical Characteristics

Characteristics	Symbol	Min	Typ	Max	Unit
Supply voltage	V_{CC}	4.75	5.0	5.25	V
Input high voltage					
• EXTAL	V_{IHC}	4.0	—	V_{CC}	V
• RESET	V_{IHR}	2.5	—	V_{CC}	V
• MODA, MODB, MODC	V_{IHM}	3.5	—	V_{CC}	V
• ACI, SHI inputs ¹	V_{IHS}	$0.7 \times V_{CC}$	—	V_{CC}	V
• All other inputs	V_{IH}	2.0	—	V_{CC}	V
Input low voltage					
• EXTAL	V_{ILC}	-0.5	—	0.6	V
• MODA, MODB, MODC	V_{ILM}	-0.5	—	2.0	V
• ACI, SHI inputs ¹	V_{ILS}	-0.5	—	$0.3 \times V_{CC}$	V
• All other inputs	V_{IL}	-0.5	—	0.8	V
Input leakage current	I_{IN}				
• EXTAL, RESET, MODA, MODB, MODC, DR		-1	—	1	μA
• Other Input Pins (@ 2.4 V/0.4 V)		-10	—	10	μA
High impedance (off-state) input current (@ 2.4 V / 0.4 V)	I_{TSI}	-10	—	10	μA
Output high voltage ($I_{OH} = -0.4 \text{ mA}$)	V_{OH}	2.4	—	—	V
Output low voltage ($I_{OL} = 3.2 \text{ mA}$)	V_{OL}	—	—	0.4	V
SCK/SCL $I_{OL} = 6.7 \text{ mA}$					
MISO/SDA $I_{OL} = 6.7 \text{ mA}$					
HOREQ $I_{OL} = 6.7 \text{ mA}$					
Internal Supply Current @ 95 MHz					
• Normal mode ⁴	I_{CCI}	—	155	—	mA
• Wait mode	I_{CCW}	—	22	TBD	mA
• Stop mode ²	I_{CCS}	—	TBD	TBD	mA
PLL supply current @ 95 MHz		—	1.2	2.0	mA
Input capacitance ³	C_{IN}	—	10	—	pF
Notes:	<ol style="list-style-type: none"> The SHI inputs are: MOSI/HA0, SS/HA2, MISO/SDA, SCK/SCL, and HREQ. In order to obtain these results, all inputs must be terminated (i.e., not allowed to float). PLL signals are disabled during Stop state. Periodically sampled and not 100% tested Maximum values can be derived using the methodology described in Section 4. Actual maximums are application dependent and may vary widely. 				

Preliminary Information

Specifications

AC Electrical Characteristics

AC ELECTRICAL CHARACTERISTICS

The timing waveforms in the AC Electrical Characteristics are tested with a V_{IL} maximum of 0.5 V and a V_{IH} minimum of 2.4 V for all inputs, except EXTAL, RESET, MODA, MODB, MODC, ACI, and SHI inputs (MOSI/HA0, SS/HA2, MISO/SDA, SCK/SCL, HREQ). These inputs are tested using the input levels set forth in the DC Electrical Characteristics. AC timing specifications that are referenced to a device input signal are measured in production with respect to the 50% point of the respective input signal's transition. DSP56011 output levels are measured with the production test machine V_{OL} and V_{OH} reference levels set at 0.8 V and 2.0 V, respectively.

All output delays are given for a 50 pF load unless otherwise specified. For load capacitance greater than 50 pF, the drive capability of the output pins typically decreases linearly:

1. At 1.5 ns per 10 pF of additional capacitance at all output pins except MOSI/HA0, MISO/SDA, SCK/SCL, HREQ
2. At 1.0 ns per 10 pF of additional capacitance at output pins MOSI/HA0, MISO/SDA, SCK/SCL, HREQ (in SPI mode only)

INTERNAL CLOCKS

Table 2-4 Internal Clocks

Characteristics	Symbol	Expression	
		Minimum	Maximum
Internal operation frequency	F	0	95 MHz
Internal clock high period <ul style="list-style-type: none"> • with PLL disabled¹ • with PLL enabled and $MF \leq 4$ • with PLL enabled and $MF > 4$ 	T_H	$ET_{H\text{minimum}}$ $0.48 \times T_C$ $0.467 \times T_C$	$ET_{H\text{maximum}}$ $0.52 \times T_C$ $0.533 \times T_C$
Internal clock low period <ul style="list-style-type: none"> • with PLL disabled (see Note) • with PLL enabled and $MF \leq 4$ • with PLL enabled and $MF > 4$ 	T_L	$ET_{L\text{minimum}}$ $0.48 \times T_C$ $0.467 \times T_C$	$ET_{L\text{maximum}}$ $0.52 \times T_C$ $0.533 \times T_C$
Internal clock cycle time	T_C	$(DF \times ET_C)/MF$	
Instruction cycle time	I_{CYC}	$2 \times T_C$	
Note: See Table 2-5 on page 2-5 for External Clock (ET) specifications.			

Preliminary Information

EXTERNAL CLOCK OPERATION

The DSP56011 system clock is externally supplied via the EXTAL pin. Timings shown in this document are valid for clock rise and fall times of 3 ns maximum. The 81 MHz speed allows the DSP56011 to take advantage of the 27 MHz system clock in DVD applications.

Table 2-5 External Clock (EXTAL)

No.	Characteristics	Sym.	81 MHz		95 MHz		Unit
			Min	Max	Min	Max	
	Frequency of external clock EXTAL	E_F	0	81	0	95	MHz
1	External clock input high—EXTAL <ul style="list-style-type: none"> • With PLL disabled (46.7%–53.3% duty cycle) • With PLL enabled (42.5%–57.5% duty cycle) 	ET_H	5.8	∞	4.9	∞	ns
			5.2	235500	4.5	235500	ns
2	External clock input low—EXTAL <ul style="list-style-type: none"> • With PLL disabled (46.7%–53.3% duty cycle) • With PLL enabled (42.5%–57.5% duty cycle) 	ET_L	5.8	∞	4.9	∞	ns
			5.2	235500	4.5	235500	ns
3	External clock cycle time <ul style="list-style-type: none"> • With PLL disabled • With PLL enabled 	ET_C	12.3	∞	10.5	∞	ns
			12.3	409600	10.5	409600	ns
4	Instruction cycle time = $I_{CYC} = 2 \times T_C$ <ul style="list-style-type: none"> • With PLL disabled • With PLL enabled 	I_{CYC}	24.7	∞	21.0	∞	ns
			24.7	819200	21.0	819200	ns

Note: EXTAL input high and input low are measured at 50% of the input transition.

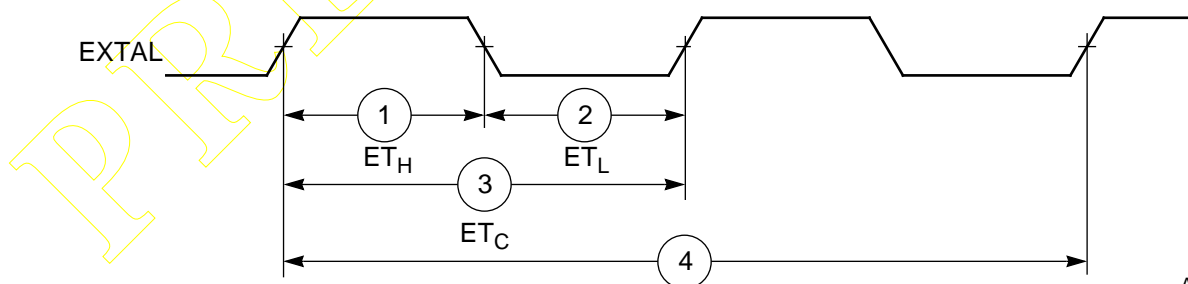

AA0250

Figure 2-1 External Clock Timing

Specifications

Phase Lock Loop (PLL) Characteristics

PHASE LOCK LOOP (PLL) CHARACTERISTICS

Table 2-6 Phase Lock Loop (PLL) Characteristics

Characteristics	Expression	Min	Max	Unit
VCO frequency when PLL enabled	$MF \times E_F$	10	f	MHz
PLL external capacitor (PCAP pin to V_{CCP})	$MF \times C_{PCAP}$ @ $MF \leq 4$ @ $MF > 4$	$MF \times 340$ $MF \times 380$	$MF \times 480$ $MF \times 970$	pF pF
Note: Cpcap is the value of the PLL capacitor (connected between PCAP pin and V_{CCP}) for $MF = 1$. The recommended value for Cpcap is 400 pF for $MF \leq 4$ and 540 pF for $MF > 4$. The maximum VCO frequency is limited to the internal operation frequency, defined in Table 2-4 .				

RESET, STOP, MODE SELECT, AND INTERRUPT TIMING

Table 2-7 Reset, Stop, Mode Select, and Interrupt Timing

No.	Characteristics	All Frequencies		Unit
		Min	Max	
10	Minimum \overline{RESET} assertion width: <ul style="list-style-type: none"> • PLL disabled • PLL enabled¹ 	$25 \times T_C$ $2500 \times ET_C$	— —	ns ns
14	Mode select setup time	21	—	ns
15	Mode select hold time	0	—	ns
16	Minimum edge-triggered interrupt request assertion width	13	—	ns
16a	Minimum edge-triggered interrupt request deassertion width	13	—	ns
18	Delay from \overline{IRQA} , \overline{IRQB} , \overline{NMI} assertion to GPIO valid caused by first interrupt instruction execution <ul style="list-style-type: none"> • GPIO0–GPIO7 • PB0–PB14 	$12 \times T_C + T_H$ $11 \times T_C + T_H$	— —	ns ns

Preliminary Information

Table 2-7 Reset, Stop, Mode Select, and Interrupt Timing (Continued)

No.	Characteristics	All Frequencies		Unit
		Min	Max	
22	Delay from General Purpose Output valid to interrupt request deassertion for level sensitive fast interrupts— if second interrupt instruction is: ² <ul style="list-style-type: none"> • Single cycle • Two cycles 		$T_L - 31$ $(2 \times T_C) + T_L - 31$	ns ns
25	Duration of \overline{IRQA} assertion for recovery from stop state	12	—	ns
27	Duration for level-sensitive \overline{IRQA} assertion to ensure interrupt service (when exiting Stop mode) <ul style="list-style-type: none"> • Stable external clock, OMR Bit 6 = 1 • Stable external clock, PCTL Bit 17 = 1 	$6 \times T_C + T_L$ 12	— —	ns ns
Notes: 1. This timing requirement is sensitive to the quality of the external PLL capacitor connected to the PCAP pin. For capacitor values <i>less than or equal to</i> 2 nF, asserting RESET according to this timing requirement will ensure proper processor initialization for capacitors with a delta C/C <i>less than</i> 0.5%. (This is typical for ceramic capacitors.) For capacitor values <i>greater than</i> 2 nF, asserting RESET according to this timing requirement will ensure proper processor initialization for capacitors with a delta C/C <i>less than</i> 0.01%. (This is typical for Teflon, polystyrene, and polypropylene capacitors.) However, capacitors with values <i>greater than</i> 2 nF with a delta C/C <i>greater than</i> 0.01% may require longer RESET assertion to ensure proper initialization. 2. When using fast interrupts and IRQA and IRQB are defined as level-sensitive, timing 22 applies to prevent multiple interrupt service. To avoid these timing restrictions, negative-edge-triggered configuration is recommended when using fast interrupts. Long interrupts are recommended when using level-sensitive configuration.				

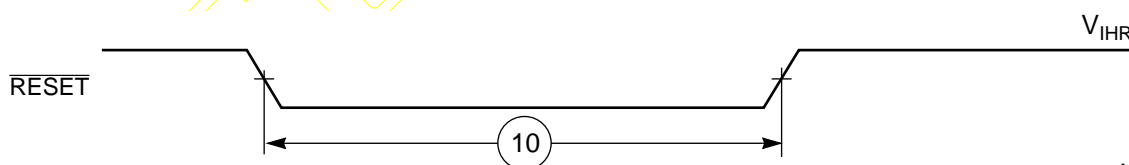

AA0251

Figure 2-2 Reset Timing

Specifications

RESET, Stop, Mode Select, and Interrupt Timing

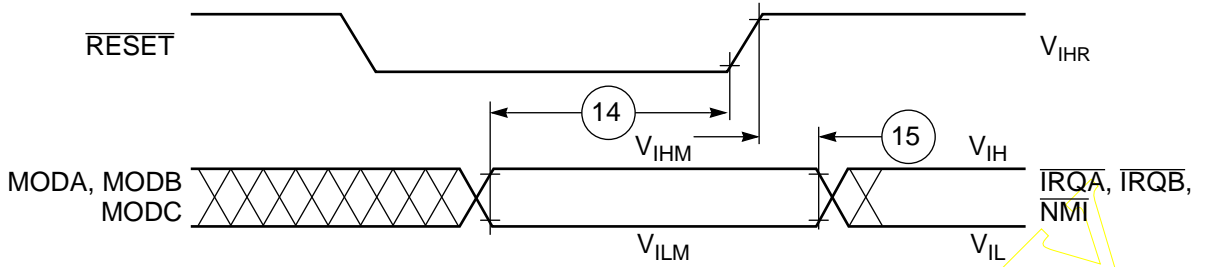

Figure 2-3 Operating Mode Select Timing

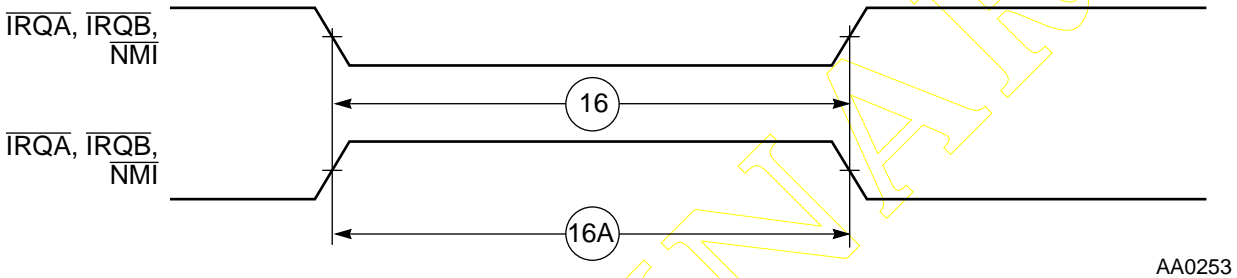

Figure 2-4 External Interrupt Timing (Negative-Edge Triggered)

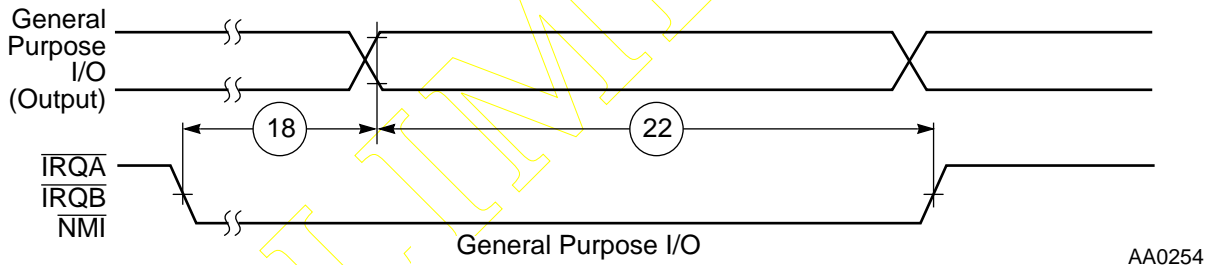

Figure 2-5 External Level-Sensitive Fast Interrupt Timing

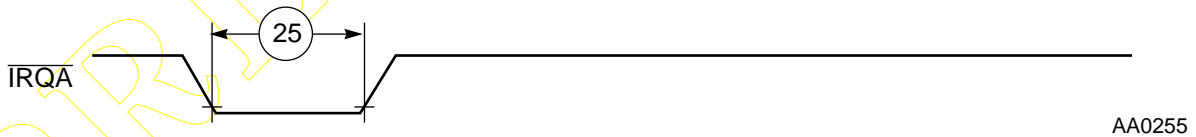

Figure 2-6 Recovery from Stop State Using \overline{IRQA}

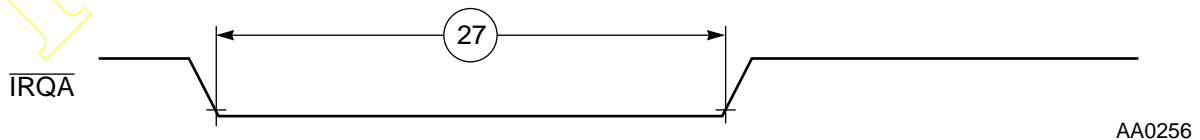

Figure 2-7 Recovery from Stop State Using \overline{IRQA} Interrupt Service

Preliminary Information

HOST INTERFACE (HI) TIMING

Note: Active low lines should be “pulled up” in a manner consistent with the AC and DC specifications.

Table 2-8 Host I/O Timing (All Frequencies)

Num	Characteristics	Min	Max	Unit
31	$\overline{\text{HEN}}/\overline{\text{HACK}}$ assertion width ¹ <ul style="list-style-type: none"> • CVR, ICR, ISR, RXL read • IVR, RXH/M read • Write 	$T_C + 31$ 26 13	— — —	ns
32	$\overline{\text{HEN}}/\overline{\text{HACK}}$ deassertion width ¹ <ul style="list-style-type: none"> • After TXL writes² • After RXL reads³ • Between two CVR, ICR, or ISR reads 	13 $2 \times T_C + 31$ $2 \times T_C + 31$ $2 \times T_C + 31$	— — — —	ns ns ns ns
33	Host data input setup time before $\overline{\text{HEN}}/\overline{\text{HACK}}$ deassertion	4	—	ns
34	Host data input hold time after $\overline{\text{HEN}}/\overline{\text{HACK}}$ deassertion	3	—	ns
35	$\overline{\text{HEN}}/\overline{\text{HACK}}$ assertion to output data active from high impedance	0	—	ns
36	$\overline{\text{HEN}}/\overline{\text{HACK}}$ assertion to output data valid	—	26	ns
37	$\overline{\text{HEN}}/\overline{\text{HACK}}$ deassertion to output data high impedance ⁵	—	18	ns
38	Output data hold time after $\overline{\text{HEN}}/\overline{\text{HACK}}$ Deassertion ⁶	2.5	—	ns
39	HR/ $\overline{\text{W}}$ low setup time before $\overline{\text{HEN}}$ assertion	0	—	ns
40	HR/ $\overline{\text{W}}$ low hold time after $\overline{\text{HEN}}$ deassertion	3	—	ns
41	HR/ $\overline{\text{W}}$ high setup time to $\overline{\text{HEN}}$ assertion	0	—	ns
42	HR/ $\overline{\text{W}}$ high hold time after $\overline{\text{HEN}}/\overline{\text{HACK}}$ deassertion	3	—	ns
43	HOA0–HOA2 setup time before $\overline{\text{HEN}}$ assertion	0	—	ns
44	HOA0–HOA2 Hold Time After $\overline{\text{HEN}}$ Deassertion	3	—	ns
45	DMA $\overline{\text{HACK}}$ assertion to $\overline{\text{HOREQ}}$ deassertion ⁴	3	45	ns
46	DMA $\overline{\text{HACK}}$ deassertion to $\overline{\text{HOREQ}}$ assertion ^{4,5} <ul style="list-style-type: none"> • For DMA RXL read • For DMA TXL write • All other cases 	$T_L + T_C + T_H$ $T_L + T_C$ 0	— — —	ns ns ns

Preliminary Information

Specifications

Host Interface (HI) Timing

Table 2-8 Host I/O Timing (All Frequencies) (Continued)

Num	Characteristics	Min	Max	Unit
47	Delay from $\overline{\text{HEN}}$ deassertion to $\overline{\text{HOREQ}}$ assertion for RXL read ^{4,5}	$T_L + T_C + T_H$	—	ns
48	Delay from $\overline{\text{HEN}}$ deassertion to $\overline{\text{HOREQ}}$ assertion for TXL write ^{4,5}	$T_L + T_C$	—	ns
49	Delay from $\overline{\text{HEN}}$ assertion to $\overline{\text{HOREQ}}$ deassertion for RXL read, TXL write ^{4,5}	3	58	ns

Notes:

1. See **Host Port Considerations** in **Section 4 Design Considerations**.
2. This timing is applicable only if a write to the TXL is followed by writing the TXL, TXM, or TXH registers without first polling the TXDE or $\overline{\text{HOREQ}}$ flags, or waiting for $\overline{\text{HOREQ}}$ to be asserted.
3. This timing is applicable only if a read from the RXL is followed by reading the RXL, RXM or RXH registers without first polling the RXDF or $\overline{\text{HOREQ}}$ flags, or waiting for $\overline{\text{HOREQ}}$ to be asserted.
4. $\overline{\text{HOREQ}}$ is pulled up by a 1 k Ω resistor.
5. Specifications are periodically sampled and not 100% tested.
6. May decrease to 0 ns for future versions

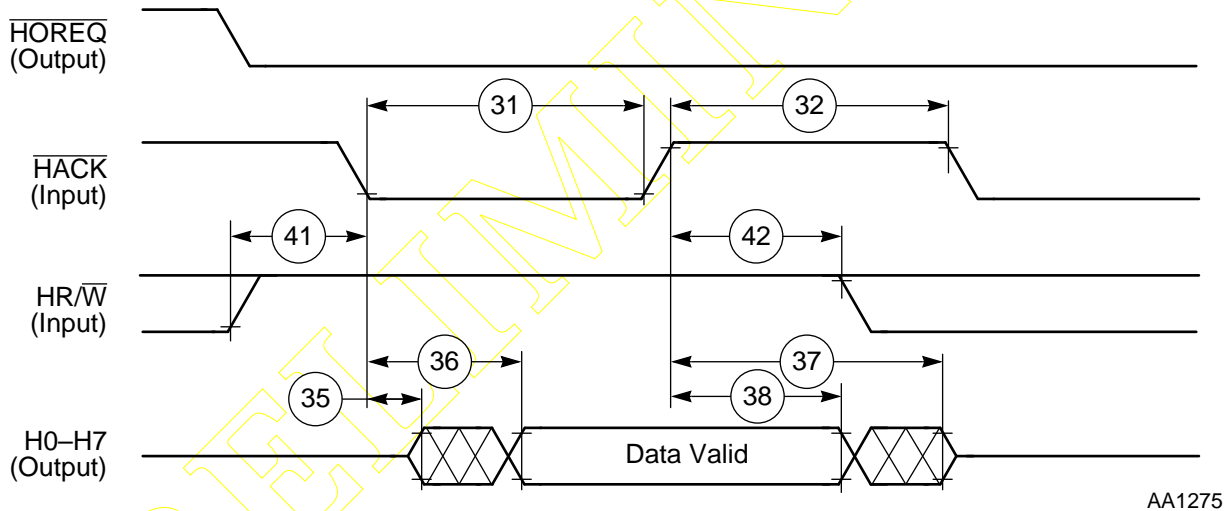

AA1275

Figure 2-8 Host Interrupt Vector Register (IVR) Read

Preliminary Information

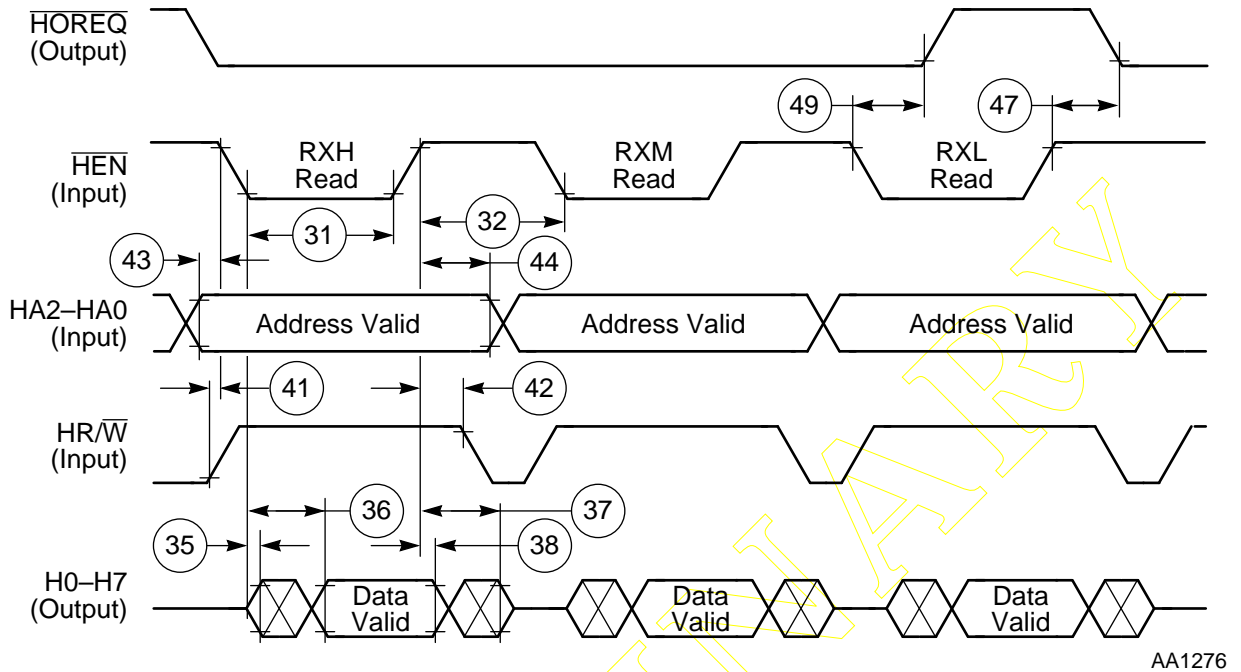

Figure 2-9 Host Read Cycle (Non-DMA Mode)

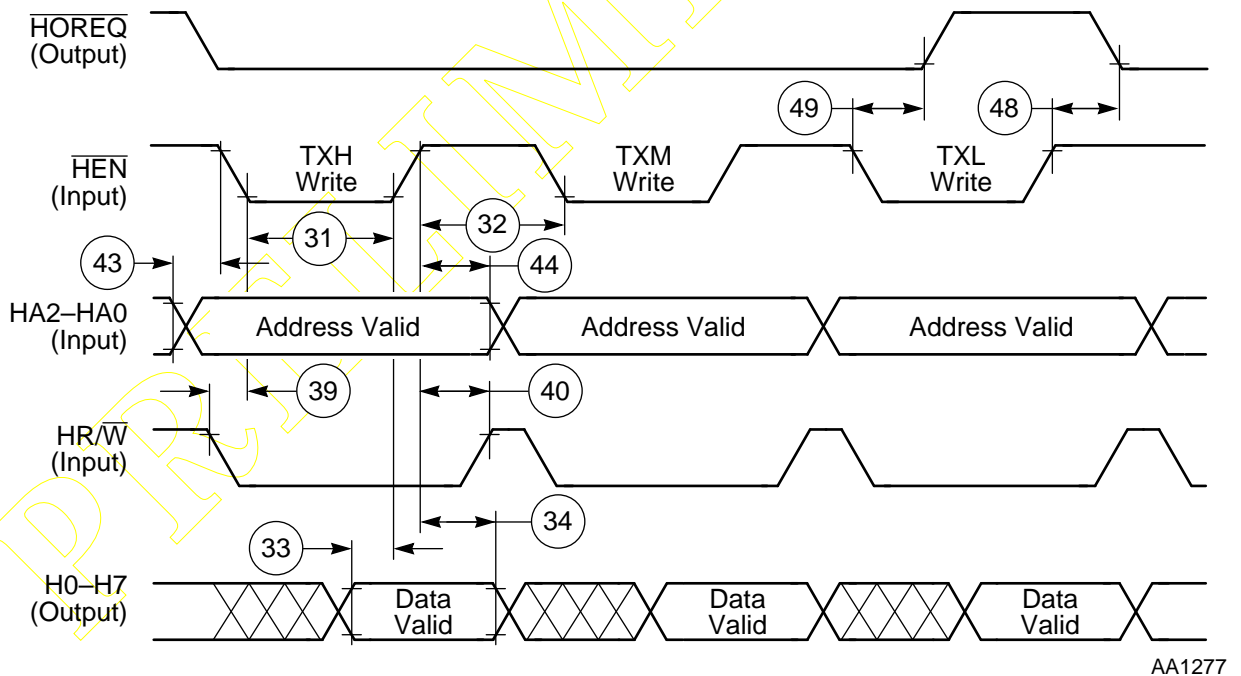

Figure 2-10 Host Write Cycle (Non-DMA Mode)

Specifications

Host Interface (HI) Timing

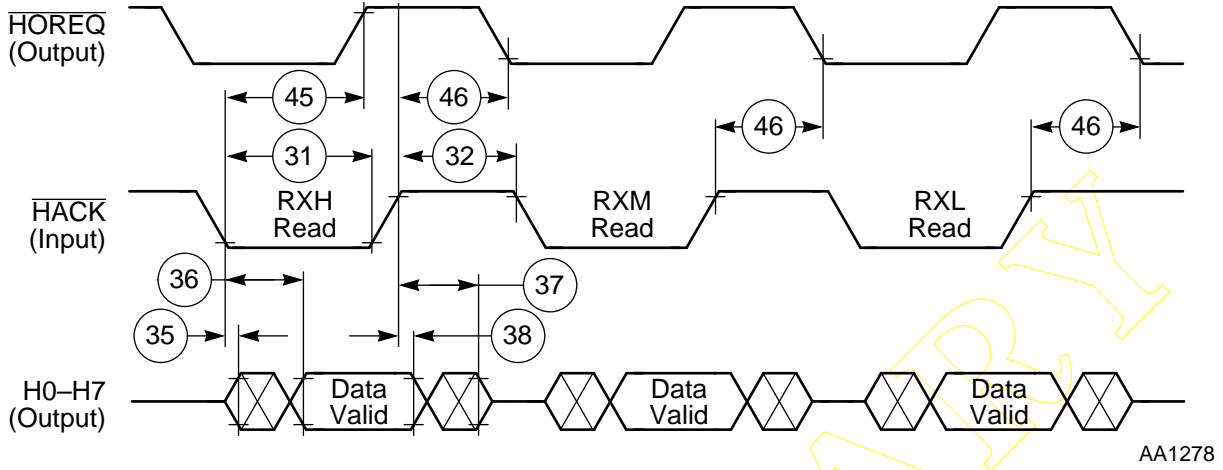

Figure 2-11 Host DMA Read Cycle

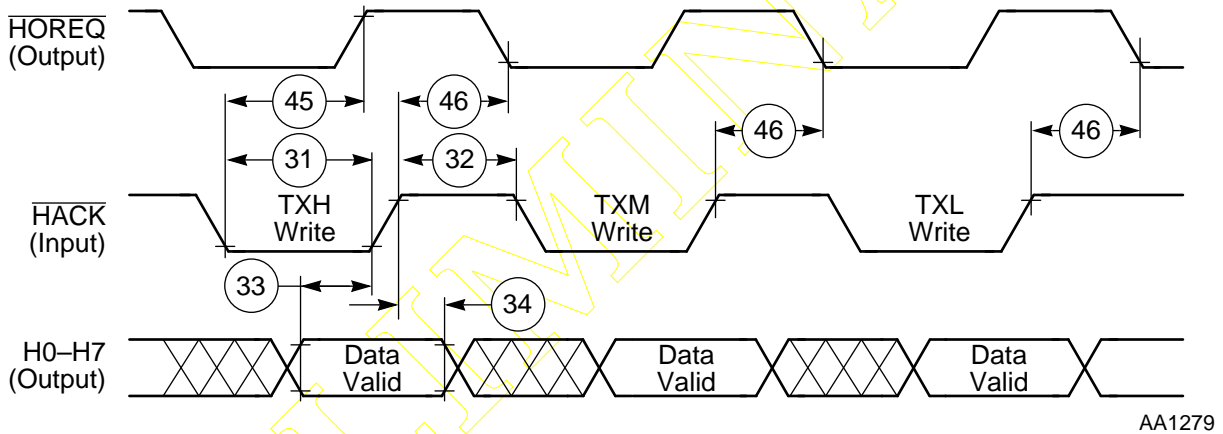

Figure 2-12 Host DMA Write Cycle

SERIAL AUDIO INTERFACE (SAI) TIMING**Table 2-9** Serial Audio Interface (SAI) Timing

No.	Characteristics	Mode	Expression	81 MHz		95 MHz		Unit
				Min	Max	Min	Max	
111	Minimum Serial Clock cycle = T_{SAICC} (min)	Master	$4 \times T_C$	49.4	—	42	—	ns
		Slave	$3 \times T_C + 5$	42	—	36.5	—	ns
112	Serial Clock high period	Master	$0.5 \times T_{SAICC} - 8$	16.7	—	13	—	ns
		Slave	$0.35 \times T_{SAICC}$	14.7	—	12.8	—	ns
113	Serial Clock low period	Master	$0.5 \times T_{SAICC} - 8$	16.7	—	13	—	ns
		Slave	$0.35 \times T_{SAICC}$	14.7	—	12.8	—	ns
114	Serial Clock rise/fall time	Master	8	—	8	—	8	ns
		Slave	$0.15 \times T_{SAICC}$	—	6.3	—	5.5	ns
115	Data input valid to SCKR edge (data input setup time)	Master	26	26	—	26	—	ns
		Slave	4	4	—	4	—	ns
116	SCKR edge to data input not valid (data input hold time)	Master	0	0	—	0	—	ns
		Slave	14	14	—	14	—	ns
117	SCKR edge to word select output valid (WSR out delay time)	Master	20	—	20	—	20	ns
118	Word select input valid to SCKR edge (WSR in setup time)	Slave	12	12	—	12	—	ns
119	SCKR edge to word select input not valid (WSR in hold time)	Slave	12	12	—	12	—	ns
121	SCKT edge to data output valid (data out delay time)	Master	13	—	13	—	13	ns
		Slave ¹	40	—	40	—	40	ns
		Slave ²	$T_H + 34$	—	40.2	—	39.25	ns
122	SCKT edge to word select output valid (WST output delay time)	Master	19	—	19	—	19	ns
123	Word select input valid to SCKT edge (WST in setup time)	Slave	12	12	—	12	—	ns
124	SCKT edge to word select input not valid (WST in hold time)	Slave	12	12	—	12	—	ns

Notes: 1. When the Frequency Ratio between Parallel and Serial clocks is 1:4 or greater
2. When the Frequency Ratio between Parallel and Serial clocks is 1:3 – 1:4

Preliminary Information

Specifications

Serial Audio Interface (SAI) Timing

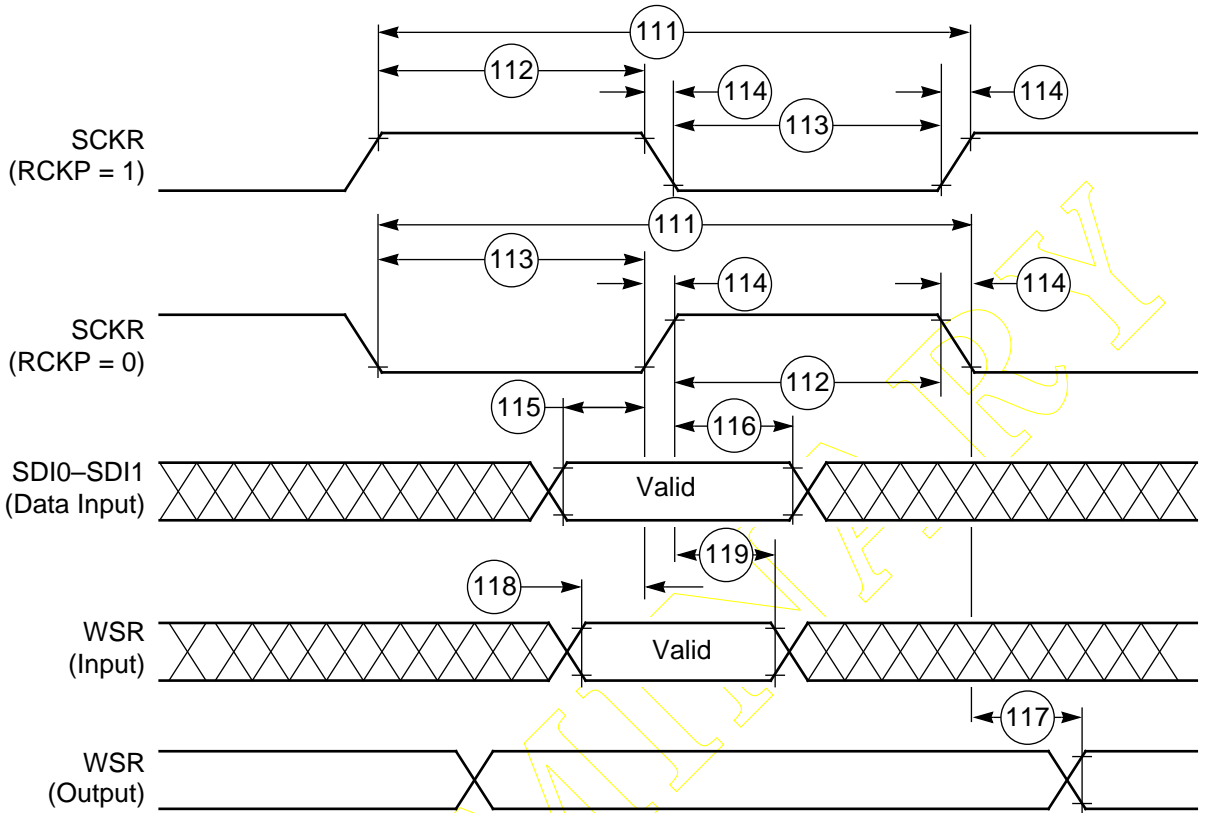

AA0269

Figure 2-13 SAI Receiver Timing

Serial Audio Interface (SAI) Timing

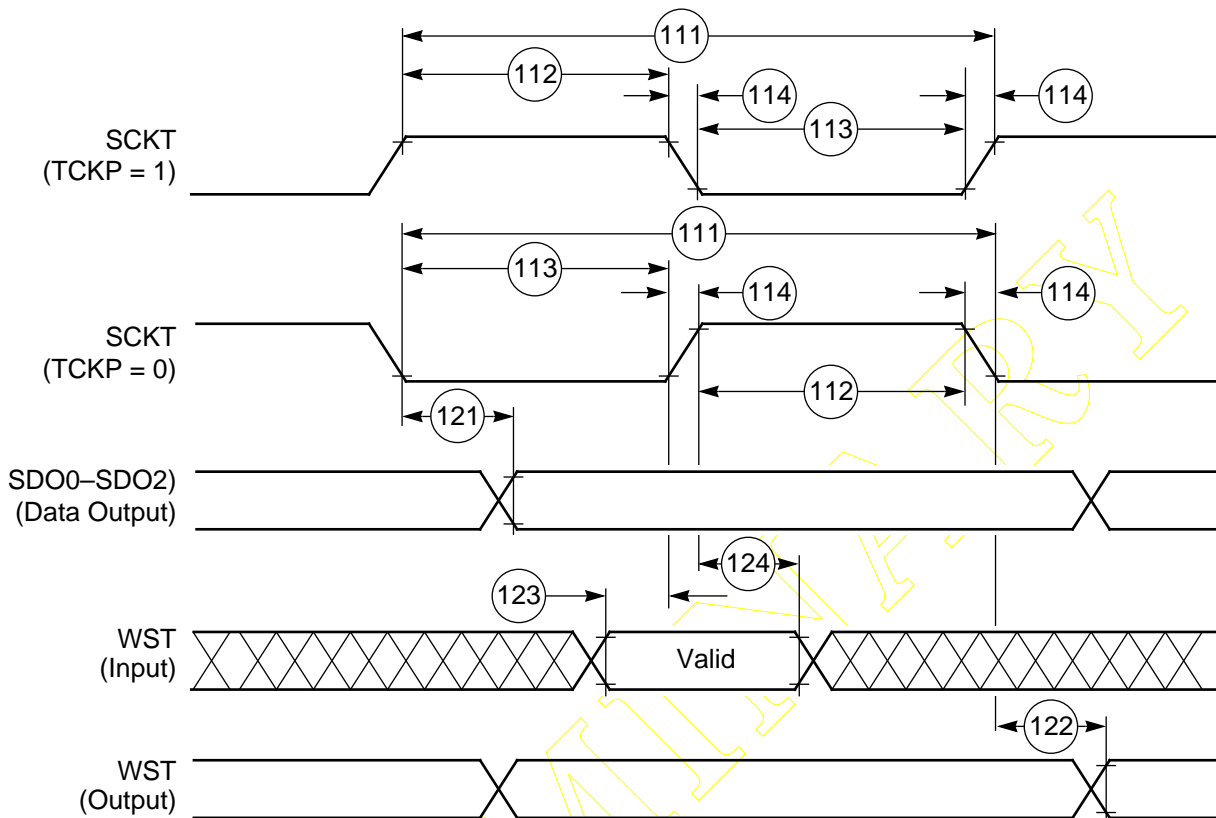

AA0270

Figure 2-14 SAI Transmitter Timing

Specifications

Serial Host Interface (SHI) SPI Protocol Timing

SERIAL HOST INTERFACE (SHI) SPI PROTOCOL TIMING

Table 2-10 Serial Host Interface (SHI) SPI Protocol Timing

No.	Characteristics	Mode	Filter Mode	Expression	81 MHz		95 MHz		Unit
					Min	Max	Min	Max	
—	Tolerable spike width on Clock or Data input		Bypassed		—	0	—	0	ns
			Narrow		—	20	—	20	ns
			Wide		—	100	—	100	ns
141	Minimum Serial Clock cycle = $t_{SPICC}(\min)$	Master	Bypassed	$4 \times T_C$	—	—	—	—	ns
					• Frequency below 33 MHz ¹				
	• Frequency above 33 MHz ¹	Master	Bypassed	$6 \times T_C$	74.1	—	63	—	ns
			Narrow	1000	1000	—	1000	—	ns
			Wide	2000	2000	—	2000	—	ns
	CPHA = 0, CPHA = 1 ²	Slave	Bypassed	$3 \times T_C$	37	—	31.5	—	ns
			Narrow	$3 \times T_C + 25$	62	—	56.5	—	ns
			Wide	$3 \times T_C + 85$	122	—	116.5	—	ns
	CPHA = 1	Slave	Bypassed	$3 \times T_C + 79$	116	—	110.5	—	ns
			Narrow	$3 \times T_C + 431$	468	—	462.5	—	ns
			Wide	$3 \times T_C + 1022$	1059	—	1053.5	—	ns
	142	Serial Clock high period	Master		$0.5 \times T_{SPICC} - 10$	27.0	—	21.5	—
CPHA = 0, CPHA = 1 ²			Slave	Bypassed	$T_C + 8$	20.3	—	18.5	—
		Narrow	$T_C + 31$	43.3	—	41.5	—	ns	
		Wide	$T_C + 43$	55.3	—	53.5	—	ns	
CPHA = 1		Slave	Bypassed	$T_C + T_H + 40$	58.5	—	55.75	—	ns
			Narrow	$T_C + T_H + 216$	235	—	231.75	—	ns
	Wide		$T_C + T_H + 511$	536	—	526.75	—	ns	
143	Serial Clock low period	Master		$0.5 \times T_{SPICC} - 10$	27.0	—	21.5	—	ns
		CPHA = 0, CPHA = 1 ²	Slave	Bypassed	$T_C + 8$	20.3	—	18.5	—
	Narrow		$T_C + 31$	43.3	—	41.5	—	ns	
	Wide		$T_C + 43$	55.3	—	53.5	—	ns	
	CPHA = 1	Slave	Bypassed	$T_C + T_H + 40$	58.5	—	55.75	—	ns
			Narrow	$T_C + T_H + 216$	235	—	231.75	—	ns
Wide			$T_C + T_H + 511$	536	—	526.75	—	ns	

Preliminary Information

Serial Host Interface (SHI) SPI Protocol Timing

Table 2-10 Serial Host Interface (SHI) SPI Protocol Timing (Continued)

No.	Characteristics	Mode	Filter Mode	Expression	81 MHz		95 MHz		Unit
					Min	Max	Min	Max	
144	Serial Clock rise/fall time	Master		10	—	10	—	10	ns
		Slave		2000	—	2000	—	2000	ns
146	\overline{SS} assertion to first SCK edge CPHA = 0	Slave	Bypassed	$T_C + T_H + 35$	53.5	—	50.75	—	ns
			Narrow	$T_C + T_H + 35$	53.5	—	50.75	—	ns
			Wide	$T_C + T_H + 35$	53.5	—	50.75	—	ns
	CPHA = 1	Slave	Bypassed	6	6	—	6	—	ns
			Narrow	0	0	—	0	—	ns
			Wide	0	0	—	0	—	ns
147	Last SCK edge to \overline{SS} not asserted CPHA = 0	Slave	Bypassed	$T_C + 6$	18.3	—	16.5	—	ns
			Narrow	$T_C + 70$	82.4	—	80.5	—	ns
			Wide	$T_C + 197$	209	—	207.5	—	ns
	CPHA = 1 ³	Slave	Bypassed	2	2	—	2	—	ns
			Narrow	66	66	—	66	—	ns
			Wide	193	193	—	193	—	ns
148	Data input valid to SCK edge (data input setup time)	Master	Bypassed	0	0	—	0	—	ns
			Narrow	$\text{MAX}\{(37 - T_C), 0\}$	25	—	26.5	—	ns
			Wide	$\text{MAX}\{(52 - T_C), 0\}$	40	—	41.5	—	ns
		Slave	Bypassed	0	0	—	0	—	ns
			Narrow	$\text{MAX}\{(38 - T_C), 0\}$	26	—	27.5	—	ns
			Wide	$\text{MAX}\{(53 - T_C), 0\}$	41	—	42.5	—	ns
149	SCK edge to data input not valid (data in hold time)	Master	Bypassed	$2 \times T_C + 17$	41.7	—	38	—	ns
			Narrow	$2 \times T_C + 18$	42.7	—	39	—	ns
			Wide	$2 \times T_C + 28$	52.7	—	49	—	ns
		Slave	Bypassed	$2 \times T_C + 17$	41.7	—	38	—	ns
			Narrow	$2 \times T_C + 18$	42.7	—	39	—	ns
			Wide	$2 \times T_C + 28$	52.7	—	49	—	ns
150	\overline{SS} assertion to data out active	Slave		4	4	—	4	—	ns

Preliminary Information

Specifications

Serial Host Interface (SHI) SPI Protocol Timing

Table 2-10 Serial Host Interface (SHI) SPI Protocol Timing (Continued)

No.	Characteristics	Mode	Filter Mode	Expression	81 MHz		95 MHz		Unit
					Min	Max	Min	Max	
151	\overline{SS} deassertion to data tri-stated ⁴	Slave		24	—	24	—	24	ns
152	SCK edge to data out valid (data out delay time)	Master	Bypassed	41	—	41	—	41	ns
			Narrow	214	—	214	—	214	ns
			Wide	504	—	504	—	504	ns
	$CPHA = 0, CPHA = 1^2$	Slave	Bypassed	41	—	41	—	41	ns
			Narrow	214	—	214	—	214	ns
			Wide	504	—	504	—	504	ns
	$CPHA = 1$	Slave	Bypassed	$T_C + T_H + 40$	—	58.5	—	55.75	ns
			Narrow	$T_C + T_H + 216$	—	235	—	231.75	ns
			Wide	$T_C + T_H + 511$	—	536	—	536	ns
153	SCK edge to data out not valid (data out hold time)	Master	Bypassed	0	0	—	0	—	ns
			Narrow	57	57	—	57	—	ns
			Wide	163	163	—	163	—	ns
		Slave	Bypassed	0	0	—	0	—	ns
			Narrow	57	57	—	57	—	ns
			Wide	163	163	—	163	—	ns
154	\overline{SS} assertion to data output valid $CPHA = 0$	Slave		$T_C + T_H + 35$	—	53.5	—	50.75	ns
157	First SCK sampling edge to \overline{HREQ} output deassertion	Slave	Bypassed	$3 \times T_C + T_H + 32$	—	75	—	68.75	ns
			Narrow	$3 \times T_C + T_H + 209$	—	252	—	245.75	ns
			Wide	$3 \times T_C + T_H + 507$	—	550	—	543.75	ns
158	Last SCK sampling edge to \overline{HREQ} output not deasserted $CPHA = 1$	Slave	Bypassed	$2 \times T_C + T_H + 6$	36.9	—	32.25	—	ns
			Narrow	$2 \times T_C + T_H + 63$	93.9	—	89.25	—	ns
			Wide	$2 \times T_C + T_H + 169$	200	—	195.25	—	ns
159	\overline{SS} deassertion to \overline{HREQ} output not deasserted $CPHA = 0$	Slave		$2 \times T_C + T_H + 7$	37.9	—	33.25	—	ns

Preliminary Information

Serial Host Interface (SHI) SPI Protocol Timing

Table 2-10 Serial Host Interface (SHI) SPI Protocol Timing (Continued)

No.	Characteristics	Mode	Filter Mode	Expression	81 MHz		95 MHz		Unit
					Min	Max	Min	Max	
160	\overline{SS} deassertion pulse width CPHA = 0	Slave		$T_C + 4$	16.3	—	14.5	—	ns
161	\overline{HREQ} input assertion to first SCK edge	Master		$0.5 \times T_{SPICC} + 2 \times T_C + 6$	67.7	—	58.5	—	ns
162	\overline{HREQ} input deassertion to last SCK sampling edge (\overline{HREQ} input setup time) CPHA = 1	Master		0	0	—	0	—	ns
163	First SCK edge to \overline{HREQ} input not asserted (\overline{HREQ} input hold time)	Master		0	0	—	0	—	ns

Notes:

- For an internal clock frequency below 33 MHz, the minimum permissible internal clock to SCK frequency ratio is 4:1.
For an internal clock frequency above 33 MHz, the minimum permissible internal clock to SCK frequency ratio is 6:1.
- In CPHA = 1 mode, the SPI slave supports data transfers at $T_{SPICC} = 3 \times T_C$, if the user assures that the HTX is written at least T_C ns before the first edge of SCK of each word. In CPHA = 1 mode, the SPI slave supports data transfers at $T_{SPICC} = 3 \times T_C$, if the user assures that the HTX is written at least T_C ns before the first edge of SCK of each word.
- When CPHA = 1, the \overline{SS} line may remain active low between successive transfers.
- Periodically sampled, not 100% tested

Specifications

Serial Host Interface (SHI) SPI Protocol Timing

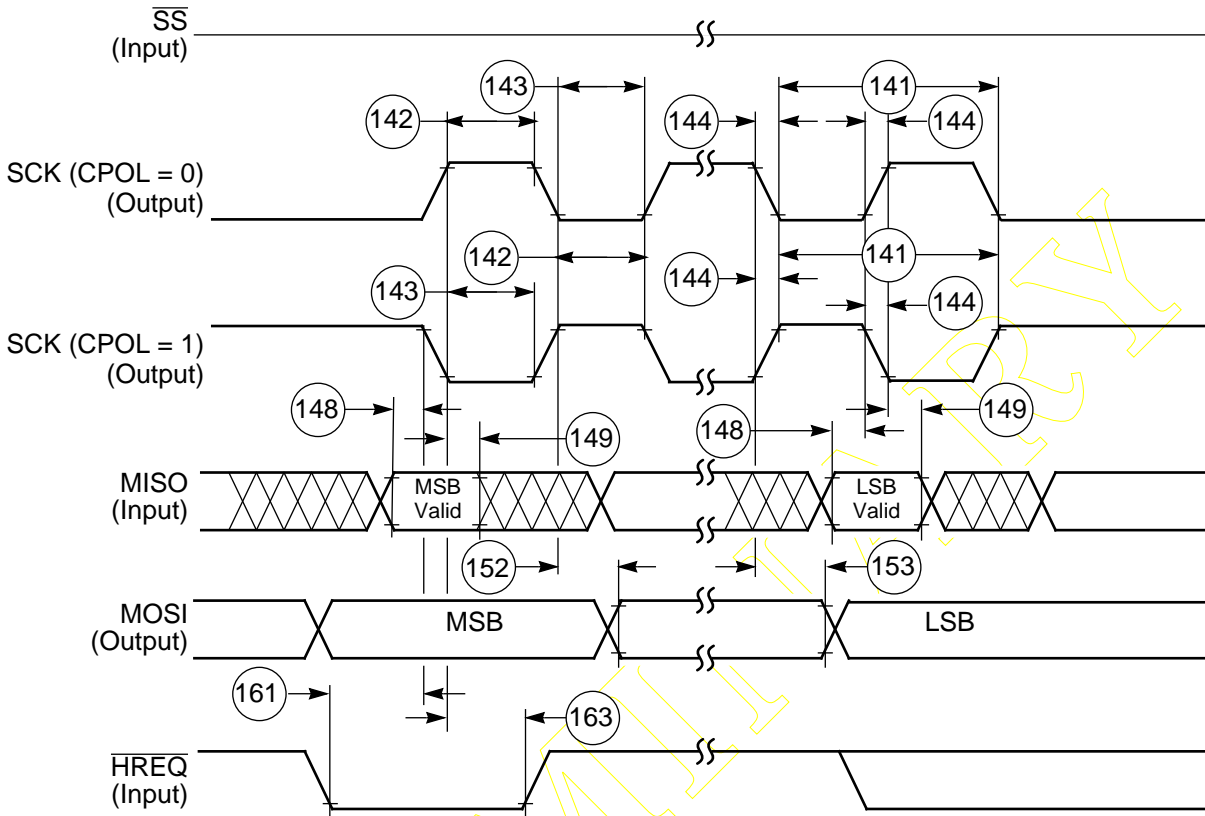

AA0271

Figure 2-15 SPI Master Timing (CPHA = 0)

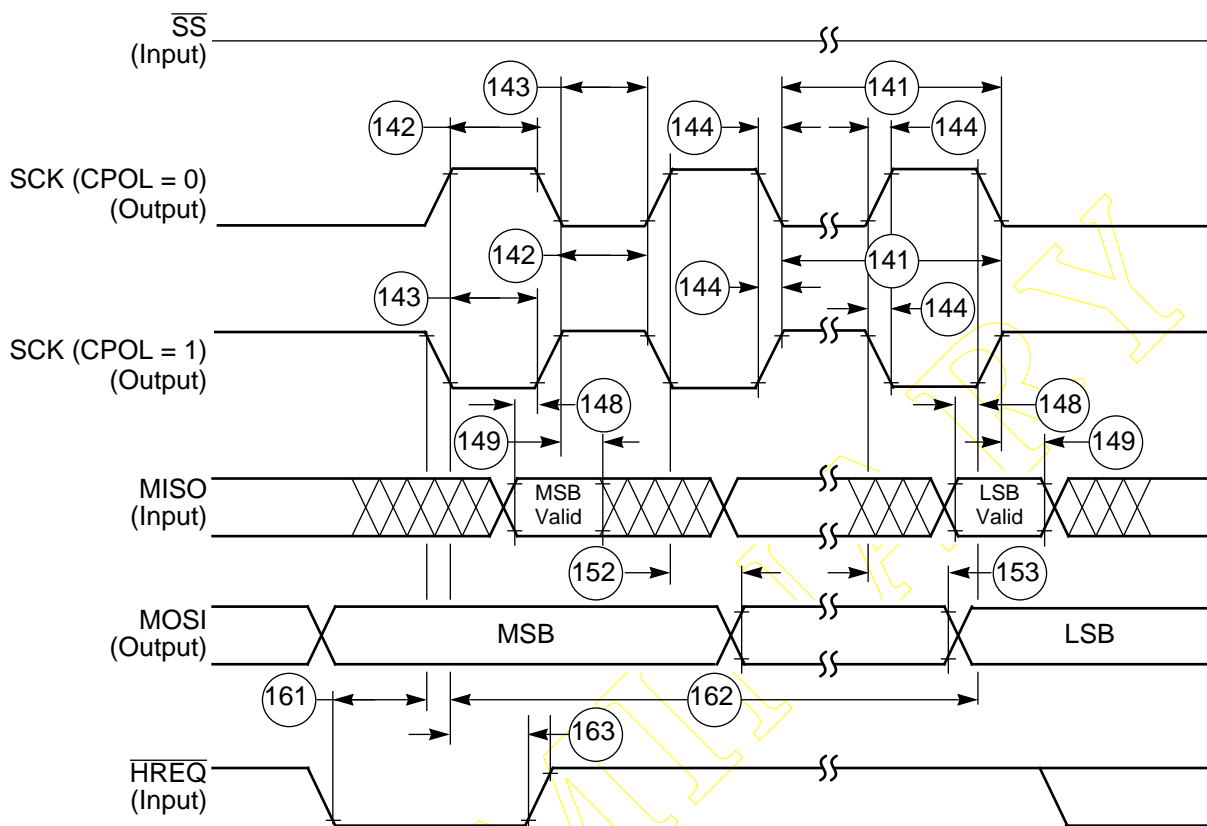

AA0272

Figure 2-16 SPI Master Timing (CPHA = 1)

Specifications

Serial Host Interface (SHI) SPI Protocol Timing

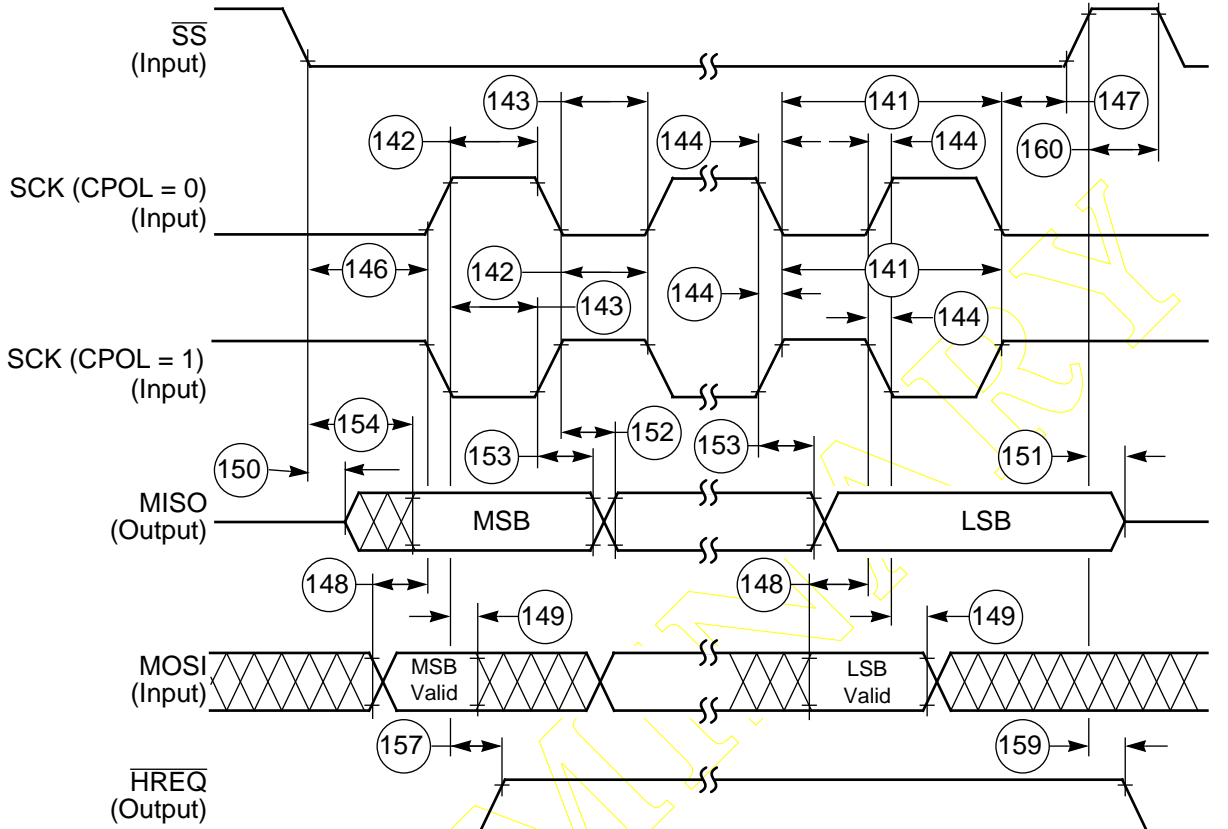

AA0273

Figure 2-17 SPI Slave Timing (CPHA = 0)

Serial Host Interface (SHI) SPI Protocol Timing

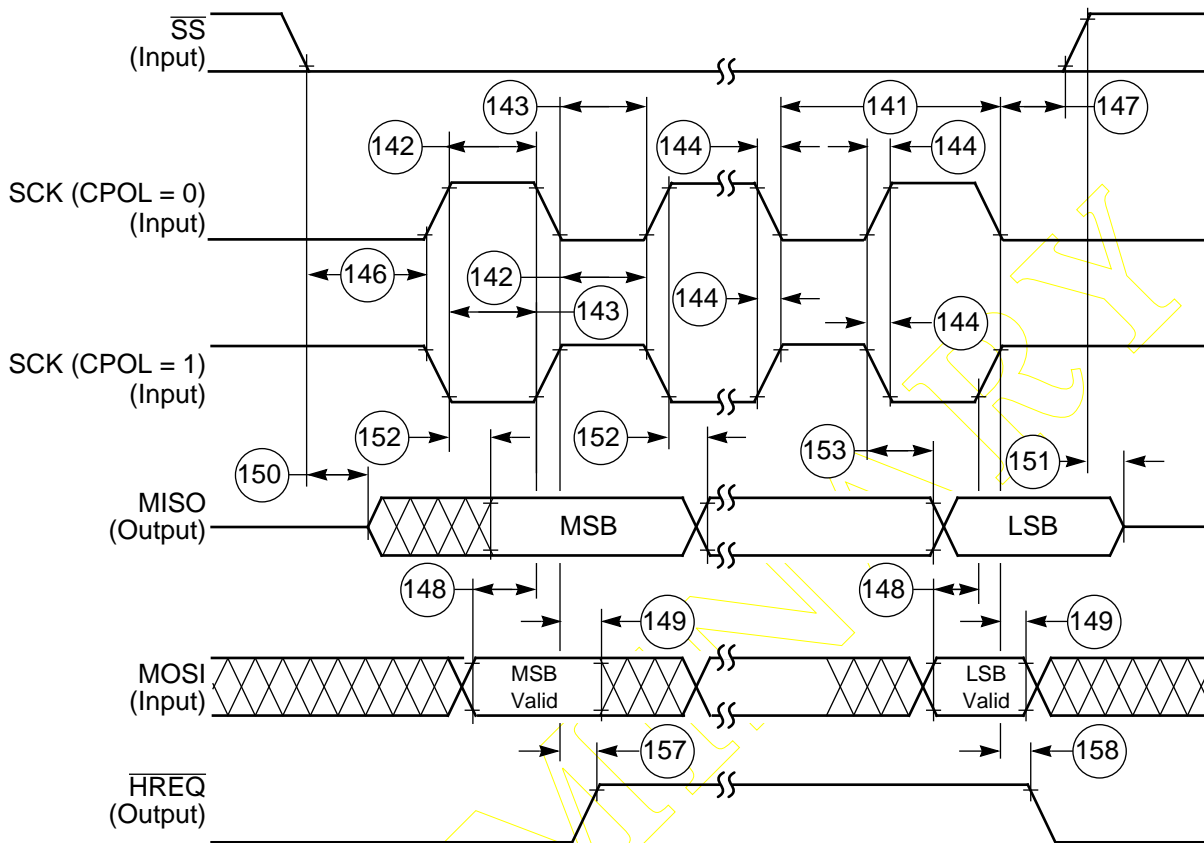

AA0274

Figure 2-18 SPI Slave Timing (CPHA = 1)

PRELIMINARY

Specifications

Serial Host Interface (SHI) I²C Protocol Timing

SERIAL HOST INTERFACE (SHI) I²C PROTOCOL TIMING

R_p (min) = 1.5 k Ω

Table 2-11 SHI I²C Protocol Timing

Standard I ² C ($C_L = 400$ pF, $R_p = 2$ k Ω , 100 kHz)					
No.	Characteristics	Symbol	All Frequencies		Unit
			Min	Max	
	Tolerable spike width on SCL or SDA filters bypassed		—	0	ns
	Narrow filters enabled		—	20	ns
	Wide filters enabled		—	100	ns
171	Minimum SCL Serial Clock cycle	T_{SCL}	10.0	—	μ s
172	Bus free time	T_{BUF}	4.7	—	μ s
173	Start condition setup time	$T_{SU;STA}$	4.7	—	μ s
174	Start condition hold time	$T_{HD;STA}$	4.0	—	μ s
175	SCL low period	T_{LOW}	4.7	—	μ s
176	SCL high period	T_{HIGH}	4.0	—	μ s
177	SCL and SDA rise time	T_R	—	1.0	μ s
178	SCL and SDA fall time	T_F	—	0.3	μ s
179	Data setup time	$T_{SU;DAT}$	250	—	ns
180	Data hold time	$T_{HD;DAT}$	0.0	—	ns
182	SCL low to data output valid	$T_{VD;DAT}$	—	3.4	μ s
183	Stop condition setup time	$T_{SU;STO}$	4.0	—	μ s

Preliminary Information

Programming the Serial Clock

The Programmed Serial Clock Cycle, $t_{I^2C_{CCP}}$, is specified by the value of the HDM5–HDM0 and HRS bits of the HCKR (SHI Clock control Register).

The expression for $t_{I^2C_{CCP}}$ is:

$$t_{I^2C_{CCP}} = [T_C \times 2 \times (HDM[5:0] + 1) \times (7 \times (1 - HRS) + 1)]$$

where

- HRS is the Prescaler Rate Select bit. When HRS is cleared, the fixed divide-by-eight prescaler is operational. When HRS is set, the prescaler is bypassed.
- MDM5–HDM0 are the Divider Modulus Select bits.
- A divide ratio from 1 to 64 (HDM5–HDM0 = 0 to \$3F) may be selected.

In I²C mode, you may select a value for the Programmed Serial Clock Cycle from:

$$6 \times T_C \text{ (if HDM[5:0] = \$02 and HRS = 1)}$$

to

$$1024 \times T_C \text{ (if HDM[5:0] = \$3F and HRS = 0)}$$

The DSP56011 provides an improved I²C bus protocol. In addition to supporting the 100 kHz I²C bus protocol, the SHI in I²C mode supports data transfers at up to 1000 kHz. The actual maximum frequency is limited by the bus capacitances (C_L), the pull-up resistors (R_P), (which affect the rise and fall time of SDA and SCL, see **Table 2-12** on page 2-26), and by the input filters.

Considerations for Programming the SHI Clock Control Register (HCKR)—Clock Divide Ratio

The master must generate a bus free time greater than T172 slave when operating with a DSP56011 SHI I²C slave. **Table 2-12** describes a few examples.

Table 2-12 Considerations for Programming the SHI Clock control Register (HCKR)

Conditions to be Considered						Resulting Limitations		
Bus Load	Master Operating Freq.	Slave Operating Freq.	Master Filter Mode	Slave Filter Mode	T172 Slave	Min. Permissible t _{I²CCP}	T172 Master	Maximum I ² C Serial Frequency
C _L = 50 pF, R _P = 2 kΩ	81 MHz	81 MHz	Bypassed	Narrow	36 ns	52 × T _C	41 ns	1010 kHz
					60 ns	56 × T _C	66 ns	825 kHz
					95 ns	62 × T _C	103 ns	634 kHz
C _L = 50 pF, R _P = 2 kΩ	95 MHz	95 MHz	Bypassed	Narrow	32 ns	60 × T _C	35 ns	1030 kHz
					56 ns	64 × T _C	56 ns	843 kHz
					91 ns	71 × T _C	92.8 ns	645 kHz

Example: for C_L = 50 pF, R_P = 2 kΩ, f = 81 MHz, Bypassed filter mode: The master, when operating with a DSP56011 SHI I²C slave with an 81 MHz operating frequency, must generate a bus free time greater than 36 ns (T172 slave). Thus, the minimum permissible T_{I²CCP} is 52 × T_C, which gives a bus free time of at least 41 ns (T172 master). This implies a maximum I²C serial frequency of 1010 kHz.

In general, bus performance may be calculated from the C_L and R_P of the bus, the input filter modes and operating frequencies of the master and the slave. **Table 2-13** on page 2-27 contains the expressions required to calculate all relevant performance timing for a given C_L and R_P.

Note: T177 (t_r) is computed using the values of C_L and R_P and T178 (T_F) is computed using the value of C_L. The two values are used in computing many of the other timing values in **Table 2-13** on page 2-27.

Table 2-13 SHI Improved I²C Protocol Timing

Improved I ² C (C _L = 50 pF, R _p = 2 kΩ)										
No.	Characteristic	Sym.	Mode	Filter Mode	Expression	81 MHz ²		95 MHz ³		Unit
						Min	Max	Min	Max	
—	Tolerable spike width on SCL or SDA			Bypassed	0	—	0	—	0	ns
				Narrow	20	—	20	—	20	ns
				Wide	100	—	100	—	100	ns
171	SCL Serial Clock cycle	T _{SCL}	Master	Bypassed	$T_{FCCP} + 3 \times T_C + 72 + T_R$	989	—	971.5	—	ns
				Narrow	$T_{FCCP} + 3 \times T_C + 245 + T_R$	1212	—	1186.5	—	ns
				Wide	$T_{FCCP} + 3 \times T_C + 535 + T_R$	1576	—	1550	—	ns
			Slave	Bypassed	$4 \times T_C + T_H + 172 + T_R$	466	—	457.3	—	ns
				Narrow	$4 \times T_C + T_H + 366 + T_R$	660	—	651.3	—	ns
				Wide	$4 \times T_C + T_H + 648 + T_R$	942	—	933.3	—	ns
172	Bus free time	T _{BUF}	Master	Bypassed	$0.5 \times T_{FCCP} - 42 - T_R$	41.1	—	35	—	ns
				Narrow	$0.5 \times T_{FCCP} - 42 - T_R$	65.8	—	56	—	ns
				Wide	$0.5 \times T_{FCCP} - 42 - T_R$	103	—	92.8	—	ns
			Slave	Bypassed	$2 \times T_C + 11$	35.7	—	32	—	ns
				Narrow	$2 \times T_C + 35$	59.7	—	56	—	ns
				Wide	$2 \times T_C + 70$	94.7	—	91	—	ns
173	Start condition setup time	T _{SU,STA}	Slave	Bypassed	12	12	—	12	—	ns
				Narrow	50	50	—	50	—	ns
				Wide	150	150	—	150	—	ns
174	Start condition hold time	T _{HD,STA}	Master	Bypassed	$0.5 \times T_{FCCP} + 12 - T_F$	313	—	307	—	ns
				Narrow	$0.5 \times T_{FCCP} + 12 - T_F$	338	—	328	—	ns
				Wide	$0.5 \times T_{FCCP} + 12 - T_F$	375	—	364.8	—	ns
			Slave	Bypassed	$2 \times T_C + T_H + 21$	51.9	—	47.25	—	ns
				Narrow	$2 \times T_C + T_H + 100$	131	—	126.25	—	ns
				Wide	$2 \times T_C + T_H + 200$	231	—	226.25	—	ns

Preliminary Information

Specifications

Serial Host Interface (SHI) I²C Protocol Timing

Table 2-13 SHI Improved I²C Protocol Timing (Continued)

Improved I ² C (C _L = 50 pF, R _P = 2 kΩ)										
No.	Characteristic	Sym.	Mode	Filter Mode	Expression	81 MHz ²		95 MHz ³		Unit
						Min	Max	Min	Max	
175	SCL low period	T _{LOW}	Master	Bypassed	$0.5 \times T_{FCCP} + 18 - T_F$	319	—	313	—	ns
				Narrow	$0.5 \times T_{FCCP} + 18 - T_F$	344	—	334	—	ns
				Wide	$0.5 \times T_{FCCP} + 18 - T_F$	381	—	370.75	—	ns
			Slave	Bypassed	$2 \times T_C + 74 + T_R$	337	—	333	—	ns
				Narrow	$2 \times T_C + 286 + T_R$	548.6	—	545	—	ns
				Wide	$2 \times T_C + 586 + T_R$	849	—	845	—	ns
176	SCL high period	T _{HIGH}	Master	Bypassed	$0.5 \times T_{FCCP} + 2 \times T_C + 19$	365	—	355	—	ns
				Narrow	$0.5 \times T_{FCCP} + 2 \times T_C + 144$	514	—	501	—	ns
				Wide	$0.5 \times T_{FCCP} + 2 \times T_C + 356$	763	—	749.8	—	ns
			Slave	Bypassed	$2 \times T_C + T_H - 1$	30	—	25.25	—	ns
				Narrow	$2 \times T_C + T_H + 18$	49	—	44.25	—	ns
				Wide	$2 \times T_C + T_H + 30$	61	—	56.25	—	ns
177	SCL rise time	T _R			$1.7 \times R_P \times (C_L + 20)^1$	—	238	—	238	ns
	Output					—	2000	—	2000	ns
178	SCL fall time	T _F			$20 + 0.1 \times (C_L - 50)^1$	—	20	—	20	ns
	Output					—	2000	—	2000	ns
179	Data setup time	T _{SU;DAT}		Bypassed	T _C + 8	20	—	18.5	—	ns
				Narrow	T _C + 60	72	—	70.5	—	ns
				Wide	T _C + 74	86	—	84.5	—	ns
180	Data hold time	T _{HD;DAT}		Bypassed	0	0	—	0	—	ns
				Narrow	0	0	—	0	—	ns
				Wide	0	0	—	0	—	ns

Preliminary Information

Table 2-13 SHI Improved I²C Protocol Timing (Continued)

Improved I ² C (C _L = 50 pF, R _P = 2 kΩ)										
No.	Characteristic	Sym.	Mode	Filter Mode	Expression	81 MHz ²		95 MHz ³		Unit
						Min	Max	Min	Max	
182	SCL low to data output valid	T _{VDD;DAT}		Bypassed	$2 \times T_C + 71 + T_R$	—	334	—	330	ns
				Narrow	$2 \times T_C + 244 + T_R$	—	507	—	503	ns
				Wide	$2 \times T_C + 535 + T_R$	—	798	—	794	ns
183	Stop condition setup time	T _{SU;STO}	Master	Bypassed	$0.5 \times T_{FCCP} + T_C + T_H + 11$	351	—	341.75	—	ns
				Narrow	$0.5 \times T_{FCCP} + T_C + T_H + 69$	433	—	420.75	—	ns
				Wide	$0.5 \times T_{FCCP} + T_C + T_H + 183$	584	—	571.5	—	ns
			Slave	Bypassed	11	11	—	11	—	ns
				Narrow	50	50	—	50	—	ns
				Wide	150	150	—	150	—	ns
184	$\overline{\text{HREQ}}$ input deassertion to last SCL edge (HREQ in setup time)		Master	Bypassed	0	0	—	0	—	ns
				Narrow	0	0	—	0	—	ns
				Wide	0	0	—	0	—	ns
186	First SCL sampling edge to HREQ output deassertion		Slave	Bypassed	$3 \times T_C + T_H + 32$	—	75	—	68.75	ns
				Narrow	$3 \times T_C + T_H + 209$	—	252	—	245.75	ns
				Wide	$3 \times T_C + T_H + 507$	—	550	—	543.7	ns
187	Last SCL edge to $\overline{\text{HREQ}}$ output not deasserted		Slave	Bypassed	$2 \times T_C + T_H + 6$	37	—	32.25	—	ns
				Narrow	$2 \times T_C + T_H + 63$	93.9	—	89.25	—	ns
				Wide	$2 \times T_C + T_H + 169$	200	—	195.25	—	ns
188	$\overline{\text{HREQ}}$ input assertion to first SCL edge		Master	Bypassed	$T_{FCCP} + 2 \times T_C + 6$	673	—	657	—	ns
				Narrow	$T_{FCCP} + 2 \times T_C + 6$	722	—	699	—	ns
				Wide	$T_{FCCP} + 2 \times T_C + 6$	796	—	772.5	—	ns
189	First SCL edge to $\overline{\text{HREQ}}$ input not asserted ($\overline{\text{HREQ}}$ input hold time)		Master		0	0	—	0	—	ns

Preliminary Information

Specifications

Serial Host Interface (SHI) I²C Protocol Timing

Table 2-13 SHI Improved I²C Protocol Timing (Continued)

Improved I ² C (C _L = 50 pF, R _P = 2 kΩ)										
No.	Characteristic	Sym.	Mode	Filter Mode	Expression	81 MHz ²		95 MHz ³		Unit
						Min	Max	Min	Max	
Notes: 1. C _L is in pF, R _P is in kΩ, and result is in ns. 2. A T _{FCCP} of 52 × T _C (the maximum permitted for the given bus load) was used for the calculations in the Bypassed filter mode. A T _{FCCP} of 56 × T _C (the maximum permitted for the given bus load) was used for the calculations in the Narrow filter mode. A T _{FCCP} of 62 × T _C (the maximum permitted for the given bus load) was used for the calculations in the Wide filter mode. 3. A T _{FCCP} of 60 × T _C (the maximum permitted for the given bus load) was used for the calculations in the Bypassed filter mode. A T _{FCCP} of 64 × T _C (the maximum permitted for the given bus load) was used for the calculations in the Narrow filter mode. A T _{FCCP} of 71 × T _C (the maximum permitted for the given bus load) was used for the calculations in the Wide filter mode.										

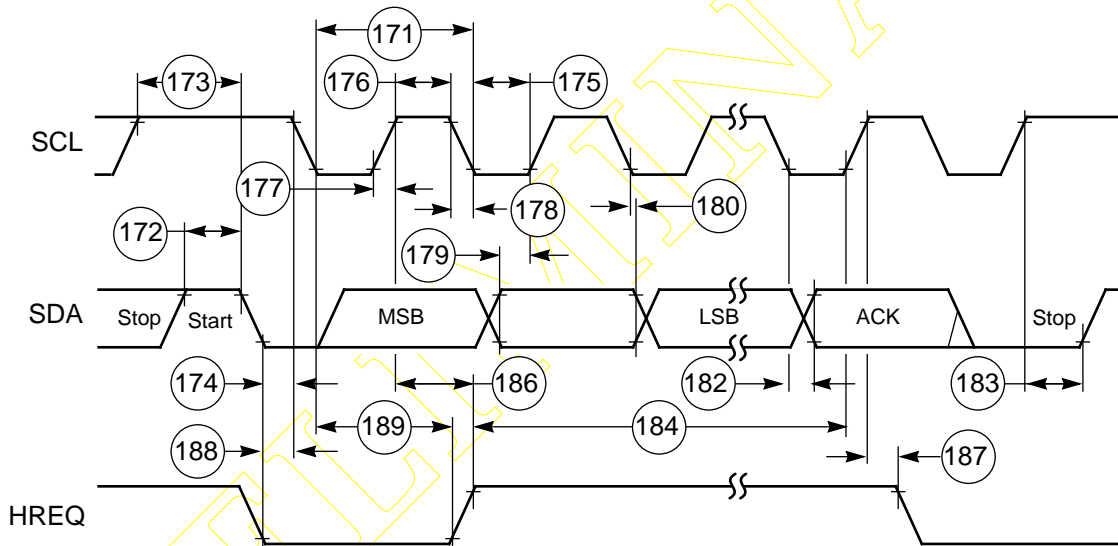

AA0275

Figure 2-19 I²C Timing

Preliminary Information

GENERAL PURPOSE INPUT/OUTPUT (GPIO) TIMING

Table 2-14 GPIO Timing

No.	Characteristics	Expression	All Frequencies		Unit
			Min	Max	
201	EXTAL edge to GPIO output valid (GPIO output delay time)	26	—	26	ns
202	EXTAL edge to GPIO output not valid (GPIO output hold time)	2	2	—	ns
203	GPIO input valid to EXTAL Edge (GPIO input setup time)	10	10	—	ns
204	EXTAL edge to GPIO input not valid (GPIO input hold time)	6	6	—	ns

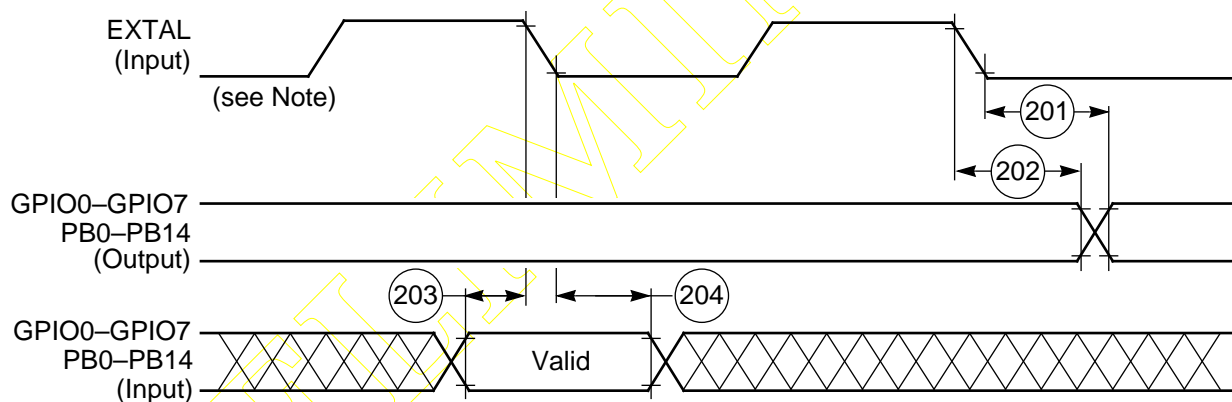

Note: Valid when the ratio between EXTAL frequency and internal clock frequency equals 1

AA1284

Figure 2-20 GPIO Timing

Specifications

Digital Audio Transmitter (DAX) Timing

DIGITAL AUDIO TRANSMITTER (DAX) TIMING

Table 2-15 56011 Digital Audio Transmitter Timing

No.	Characteristic	All Frequencies		Unit
		Min	Max	
	ACI Frequency (see Note)	—	25	MHz
220	ACI Period	40	—	ns
221	ACI High Duration	$0.5 \times T_C$	—	ns
222	ACI Low Duration	$0.5 \times T_C$	—	ns
223	ACI Rising Edge to ADO Valid	—	35	ns

Note: In order to assure proper operation of the DAX, the ACI frequency should be less than 1/2 of the DSP56011 internal clock frequency. For example, if the DSP56011 is running at 40 MHz internally, the ACI frequency should be less than 20 MHz.

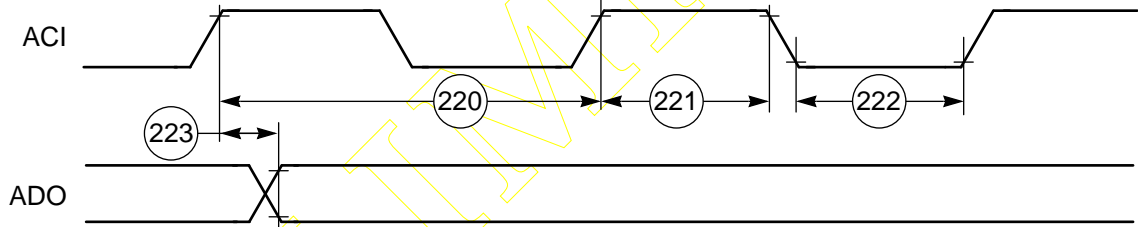

AA1280

Figure 2-21 Digital Audio Transmitter Timing

ON-CHIP EMULATION (OnCE™) TIMING

Table 2-16 OnCE Timing

No.	Characteristics	All Frequencies		Unit
		Min	Max	
230	DSCK low	40	—	ns
231	DSCK high	40	—	ns
232	DSCK cycle time	200	—	ns
233	\overline{DR} asserted to DSO (\overline{ACK}) asserted	$5 T_C$	—	ns
234	DSCK high to DSO valid	—	42	ns
235	DSCK high to DSO invalid	3	—	ns
236	DSI valid to DSCK low (setup)	15	—	ns
237	DSCK Low to DSI Invalid (Hold)	3	—	ns
238	Last DSCK low to OS0–OS1, \overline{ACK} active	$3 T_C + T_L$	—	ns
239	DSO (\overline{ACK}) asserted to first DSCK high	$2 T_C$	—	ns
240	DSO (\overline{ACK}) assertion width	$4 T_C + T_H - 3$	$5 T_C + 7$	ns
241	DSO (\overline{ACK}) asserted to OS0–OS1 high impedance ¹	—	0	ns
242	OS0–OS1 valid to second EXTAL transition	$T_C - 21$	—	ns
243	Second EXTAL transition to OS0–OS1 invalid	0	—	ns
244	Last DSCK low of read register to first DSCK high of next command	$7 T_C + 10$	—	ns
245	Last DSCK low to DSO invalid (hold)	3	—	ns
246	\overline{DR} assertion to second EXTAL transition for wake up from Wait state	10	$T_C - 10$	ns
247	Second EXTAL transition to DSO after wake up from Wait state	$17 T_C$	—	ns
248	\overline{DR} assertion width <ul style="list-style-type: none"> • To recover from Wait • To recover from Wait and enter Debug mode 	15	$12 T_C - 15$	ns
		$13 T_C + 15$	—	
249	\overline{DR} assertion to DSO (\overline{ACK}) valid (enter Debug mode) after asynchronous recovery from Wait state	$17 T_C$	—	ns

Specifications

On-Chip Emulation (OnCE™) Timing

Table 2-16 OnCE Timing (Continued)

No.	Characteristics	All Frequencies		Unit
		Min	Max	
250A	\overline{DR} assertion width to recover from Stop ² <ul style="list-style-type: none"> Stable External Clock, OMR Bit 6 = 0 Stable External Clock, OMR Bit 6 = 1 Stable External Clock, PCTL Bit 17 = 1 	15	65548 $T_C + T_L$	ns
250B	\overline{DR} assertion width to recover from Stop and enter Debug mode ² <ul style="list-style-type: none"> Stable External Clock, OMR Bit 6 = 0 Stable External Clock, OMR Bit 6 = 1 Stable External Clock, PCTL Bit 17 = 1 	65549 $T_C + T_L$	—	ns
251	\overline{DR} assertion to DSO (\overline{ACK}) valid (enter Debug mode) after recovery from Stop state ² <ul style="list-style-type: none"> Stable External Clock, OMR Bit 6 = 0 Stable External Clock, OMR Bit 6 = 1 Stable External Clock, PCTL Bit 17 = 1 	65553 $T_C + T_L$	—	ns

Notes: 1. Maximum T_L
2. Periodically sampled, not 100% tested

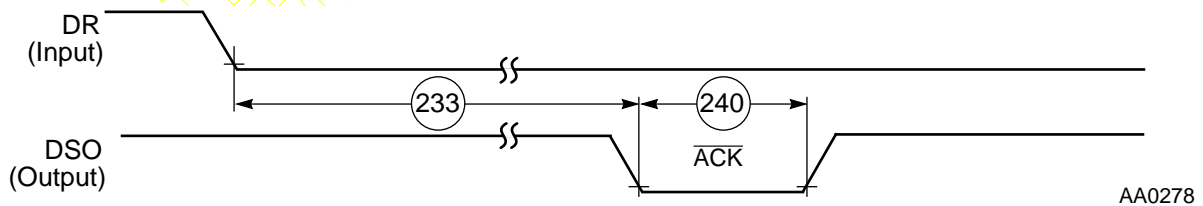
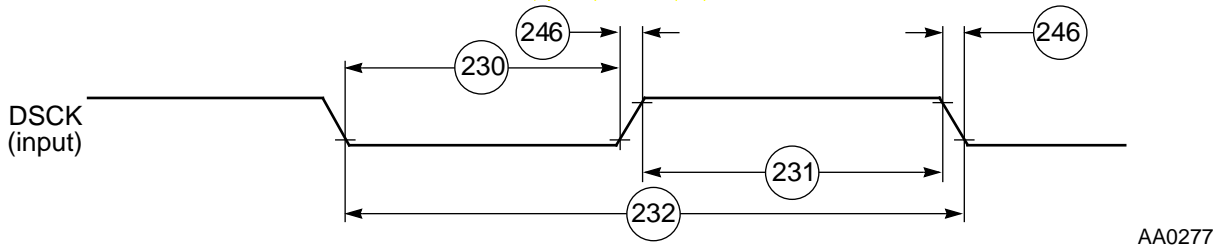

Preliminary Information

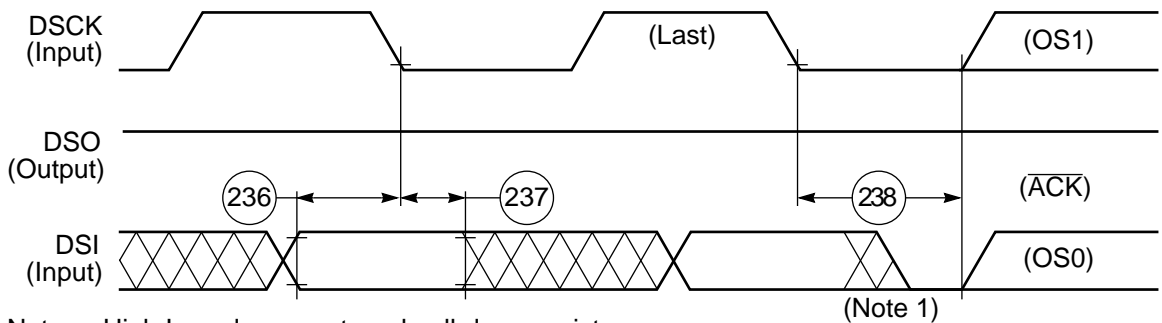

Note: High Impedance, external pull-down resistor

AA0279

Figure 2-24 DSP56011 OnCE Data I/O to Status Timing

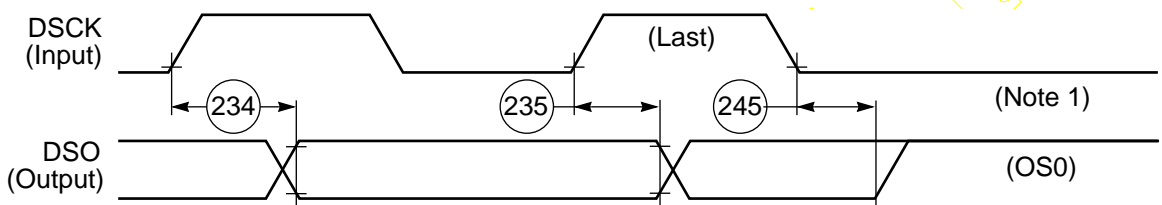

Note: High Impedance, external pull-down resistor

AA0280

Figure 2-25 DSP56011 OnCE Read Timing

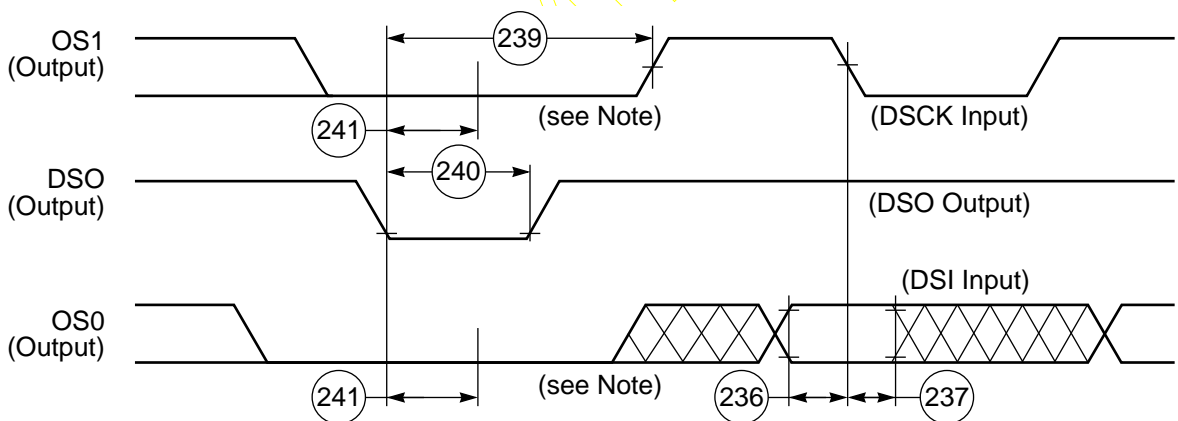

Note: High Impedance, external pull-down resistor

AA1281

Figure 2-26 DSP56011 OnCE Data I/O Status Timing

Specifications

On-Chip Emulation (OnCE™) Timing

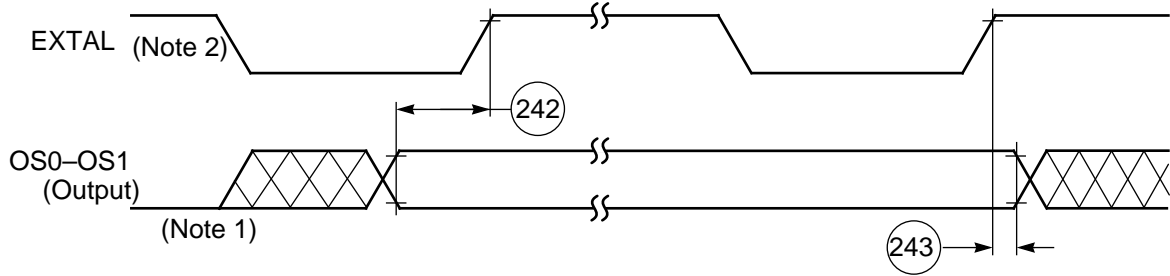

- Note: 1. High Impedance, external pull-down resistor
 2. Valid when the ratio between EXTAL frequency and clock frequency equals 1

AA0282

Figure 2-27 DSP56011 OnCE EXTAL to Status Timing

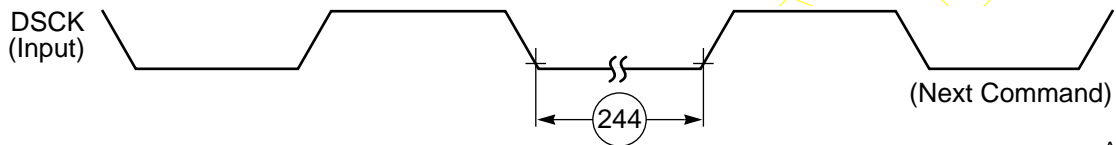

AA0283

Figure 2-28 DSP56011 OnCE DSCK Next Command After Read Register Timing

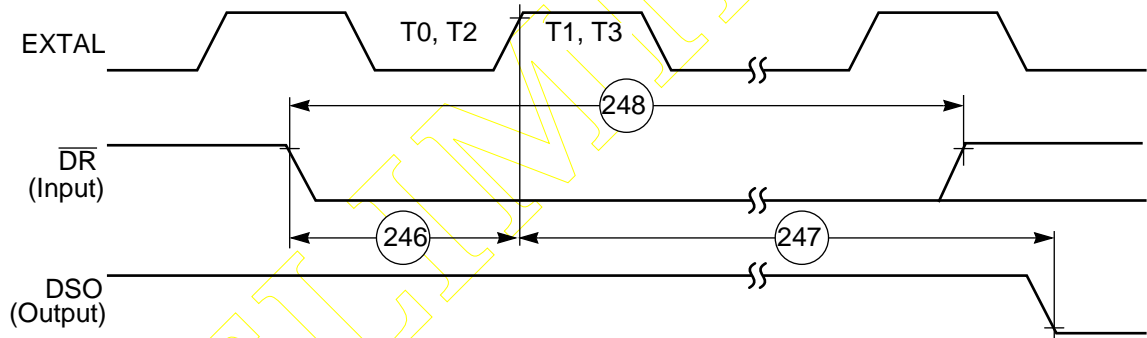

AA0284

Figure 2-29 Synchronous Recovery from Wait State

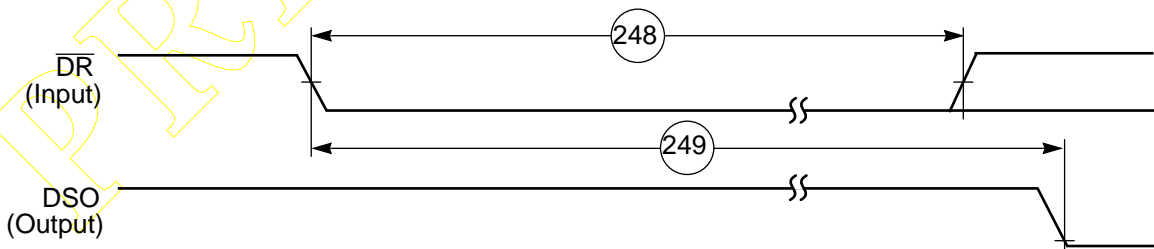

AA0285

Figure 2-30 Asynchronous Recovery from Wait State

Preliminary Information

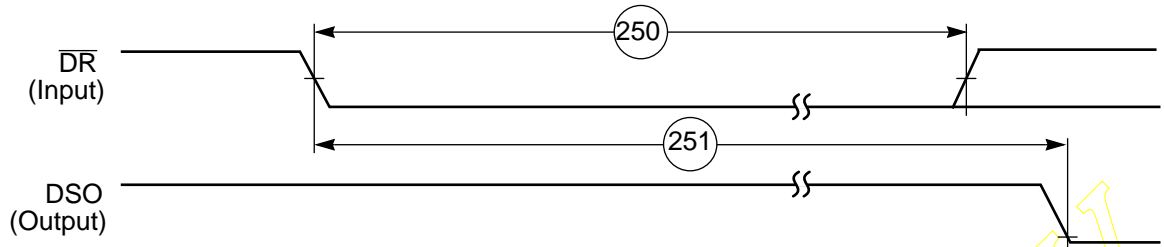

AA0286

Figure 2-31 Asynchronous Recovery from Stop State

PRELIMINARY

Specifications

On-Chip Emulation (OnCE™) Timing



PRELIMINARY

Preliminary Information

SECTION 3

PACKAGING

PIN-OUT AND PACKAGE INFORMATION

This section provides information about the available packages for this product, including diagrams of the package pinouts and tables describing how the signals described in **Section 1** are allocated. The DSP56011 is available in a 100-pin Thin Quad Flat Pack (TQFP) package.

PRELIMINARY

Preliminary Information

Packaging

Pin-out and Package Information

TQFP Package Description

Top and bottom views of the TQFP package are shown in **Figure 3-1** and **Figure 3-2** with their pin-outs.

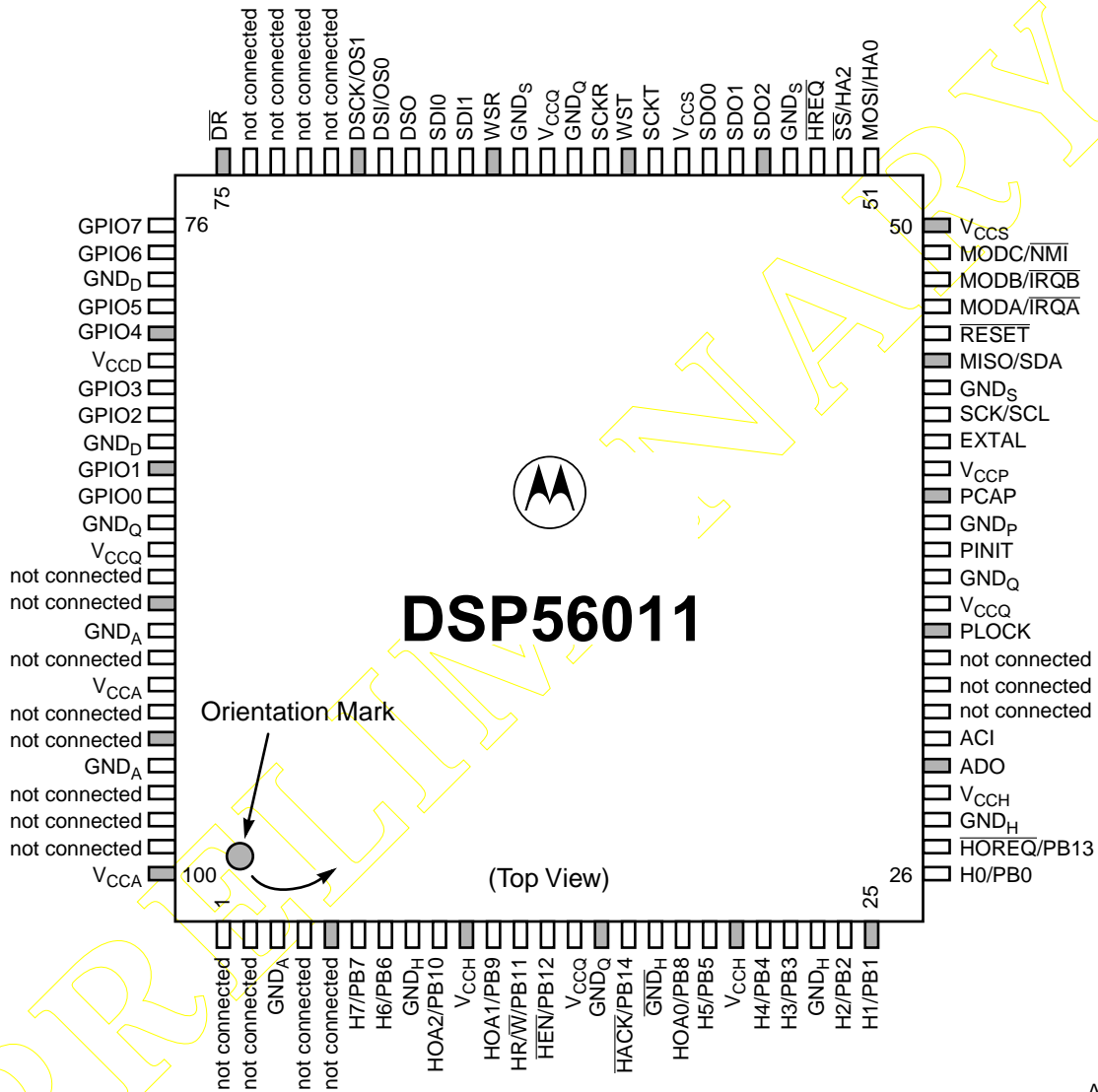

Figure 3-1 DSP56011 Thin Quad Flat Pack (TQFP), Top View

AA1282

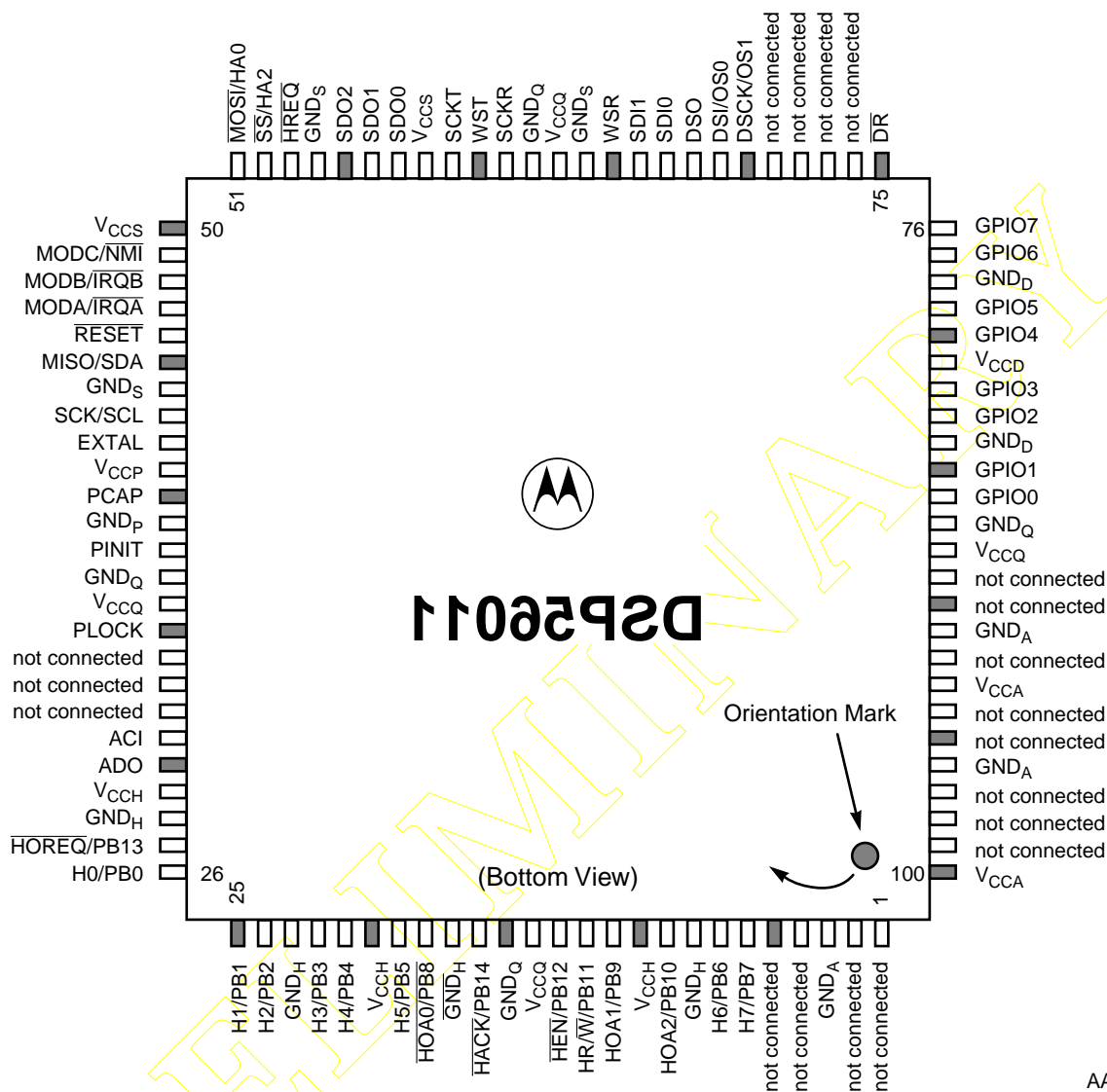

Figure 3-2 DSP56011 Thin Quad Flat Pack (TQFP), Bottom View

AA1283

Packaging

Pin-out and Package Information

Table 3-1 Signal by Pin Number

Pin #	Signal Name	Pin #	Signal Name	Pin #	Signal Name	Pin #	Signal Name
1	not connected	26	H0/PB0	51	MOSI/HA0	76	GPIO7
2	not connected	27	HOREQ/ PB13	52	SS/HA2	77	GPIO6
3	GND _A	28	GND _H	53	HREQ	78	GND _D
4	not connected	29	V _{CCH}	54	GND _S	79	GPIO5
5	not connected	30	ADO	55	SDO2	80	GPIO4
6	H7/PB7	31	ACI	56	SDO1	81	V _{CCD}
7	H6/PB6	32	not connected	57	SDO0	82	GPIO3
8	GND _H	33	not connected	58	V _{CCS}	83	GPIO2
9	HOA2/PB10	34	not connected	59	SCKT	84	GND _D
10	V _{CCH}	35	PLOCK	60	WST	85	GPIO1
11	HOA1/PB9	36	V _{CCQ}	61	SCKR	86	GPIO0
12	HR/W/PB11	37	GND _Q	62	GND _Q	87	GND _Q
13	HEN/PB12	38	PINIT	63	V _{CCQ}	88	V _{CCQ}
14	V _{CCQ}	39	GND _P	64	GND _S	89	not connected
15	GND _Q	40	PCAP	65	WSR	90	not connected
16	HACK/PB14	41	V _{CCP}	66	SDI1	91	GND _A
17	GND _H	42	EXTAL	67	SDI0	92	not connected
18	HOA0/PB8	43	SCK/SCL	68	DSO	93	V _{CCA}
19	H5/PB5	44	GND _S	69	DSI/OS0	94	not connected
20	V _{CCH}	45	MISO/SDA	70	DSCK/OS1	95	not connected
21	H4/PB4	46	RESET	71	not connected	96	GND _A
22	H3/PB3	47	MODA/ IRQA	72	not connected	97	not connected
23	GND _H	48	MODB/IRQB	73	not connected	98	not connected
24	H2/PB2	49	MODC/NMI	74	not connected	99	not connected
25	H1/PB1	50	V _{CCS}	75	DR	100	V _{CCA}

Preliminary Information

Table 3-2 Signal by Name

Signal Name	Pin #	Signal Name	Pin #	Signal Name	Pin #	Signal Name	Pin #
ACI	31	GPIO7	76	not connected	32	PB14	16
ADO	30	H0	26	not connected	33	PCAP	40
$\overline{\text{DR}}$	75	H1	25	not connected	34	PINIT	38
DSCK	70	H2	24	not connected	71	PLOCK	35
DSI	69	H3	22	not connected	72	$\overline{\text{RESET}}$	46
DSO	68	H4	21	not connected	73	SCK	43
EXTAL	42	H5	19	not connected	74	SCKR	61
GND _A	3	H6	7	not connected	89	SCKT	59
GND _A	91	H7	6	not connected	90	SCL	43
GND _A	96	$\overline{\text{HA0}}$	51	not connected	92	SDA	45
GND _D	78	HA2	52	not connected	94	SDI0	67
GND _D	84	$\overline{\text{HACK}}$	16	not connected	95	SDI1	66
GND _H	8	$\overline{\text{HEN}}$	13	not connected	97	SDO0	57
GND _H	17	HOA0	18	not connected	98	SDO1	56
GND _H	23	HOA1	11	not connected	99	SDO2	55
GND _H	28	HOA2	9	OS0	69	$\overline{\text{SS}}$	52
GND _P	39	$\overline{\text{HOREQ}}$	27	OS1	70	V _{CCA}	93
GND _Q	15	HREQ	53	PB0	26	$\overline{\text{V}}_{\text{CCA}}$	100
GND _Q	37	HR/ $\overline{\text{W}}$	12	PB1	25	V _{CDD}	81
GND _Q	62	$\overline{\text{IRQA}}$	47	PB2	24	V _{CCH}	10
GND _Q	87	$\overline{\text{IRQB}}$	48	PB3	22	V _{CCH}	20
GND _S	44	MISO	45	PB4	21	V _{CCH}	29
GND _S	64	MODA	47	PB5	19	V _{CCP}	41
GND _S	54	MODB	48	PB6	7	V _{CCQ}	14
GPIO0	86	$\overline{\text{MODC}}$	49	PB7	6	V _{CCQ}	36
GPIO1	85	$\overline{\text{MOSI}}$	51	PB8	18	V _{CCQ}	63
GPIO2	83	$\overline{\text{NMI}}$	49	PB9	11	V _{CCQ}	88
GPIO3	82	not connected	1	PB10	9	V _{CCS}	50
GPIO4	80	not connected	2	PB11	12	V _{CCS}	58
GPIO5	79	not connected	4	PB12	13	WSR	65
GPIO6	77	not connected	5	PB13	27	WST	60

Preliminary Information

Packaging

Pin-out and Package Information

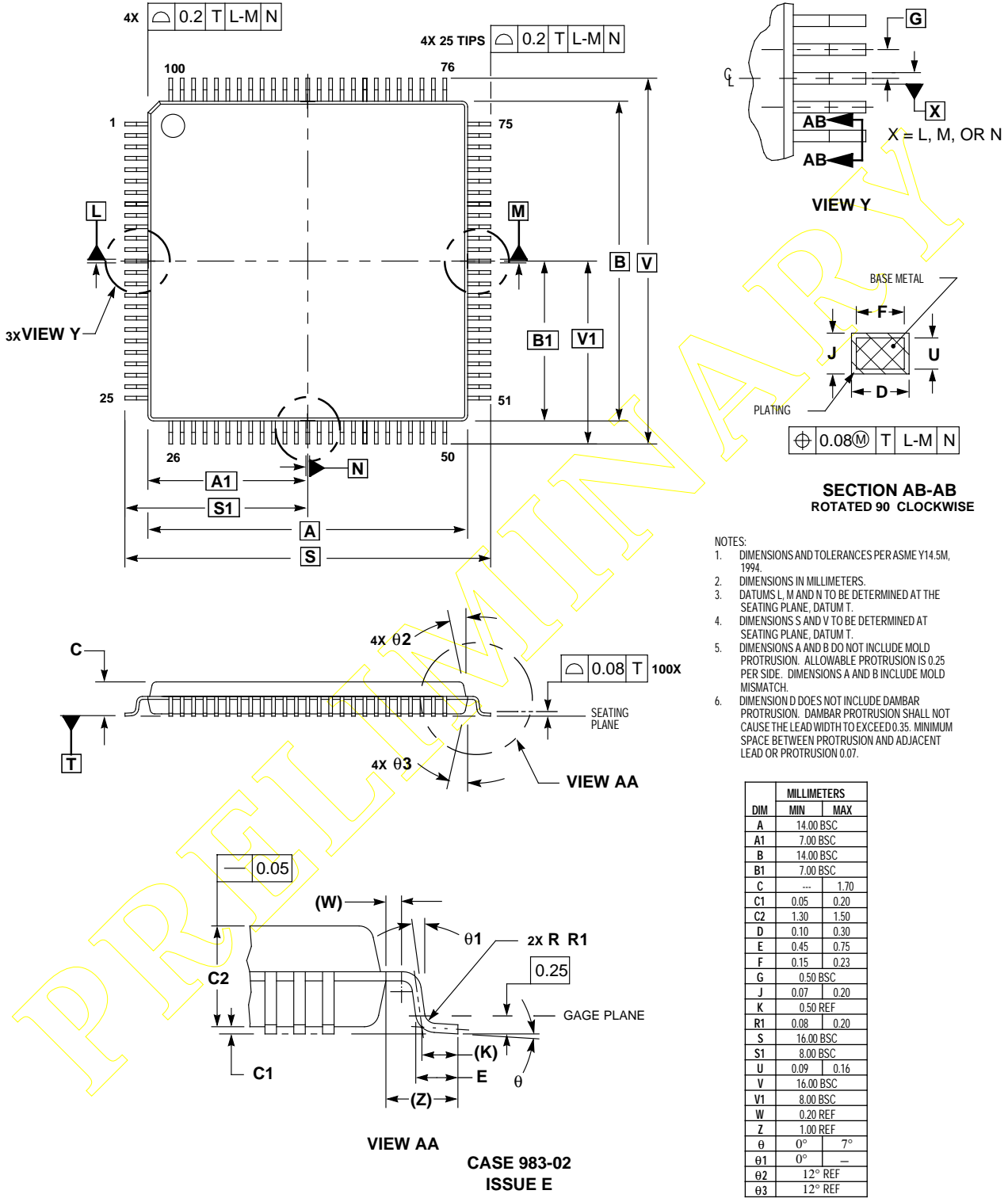

Figure 3-3 100-pin Thin Quad Flat Pack (TQFP) Mechanical Information

Preliminary Information

ORDERING DRAWINGS

Complete mechanical information regarding DSP56011 packaging is available by facsimile through Motorola's Mfax™ system. Call the following number to obtain information by facsimile:

(602) 244-6609

The Mfax automated system requests the following information:

- The receiving facsimile telephone number including area code or country code
- The caller's Personal Identification Number (PIN)

Note: For first time callers, the system provides instructions for setting up a PIN, which requires entry of a name and telephone number.

- The type of information requested:
 - Instructions for using the system
 - A literature order form
 - Specific part technical information or data sheets
 - Other information described by the system messages

A total of three documents may be ordered per call.

The DSP56011 100-pin TQFP package mechanical drawing is referenced as 983-02.



PRELIMINARY

SECTION 4

DESIGN CONSIDERATIONS

THERMAL DESIGN CONSIDERATIONS

An estimation of the chip junction temperature, T_J , in °C can be obtained from the equation:

$$\text{Equation 1: } T_J = T_A + (P_D \times R_{\theta JA})$$

Where:

T_A = ambient temperature °C

$R_{\theta JA}$ = package junction-to-ambient thermal resistance °C/W

P_D = power dissipation in package

Historically, thermal resistance has been expressed as the sum of a junction-to-case thermal resistance and a case-to-ambient thermal resistance:

$$\text{Equation 2: } R_{\theta JA} = R_{\theta JC} + R_{\theta CA}$$

Where:

$R_{\theta JA}$ = package junction-to-ambient thermal resistance °C/W

$R_{\theta JC}$ = package junction-to-case thermal resistance °C/W

$R_{\theta CA}$ = package case-to-ambient thermal resistance °C/W

$R_{\theta JC}$ is device-related and cannot be influenced by the user. The user controls the thermal environment to change the case-to-ambient thermal resistance, $R_{\theta CA}$. For example, the user can change the air flow around the device, add a heat sink, change the mounting arrangement on the printed circuit board, or otherwise change the thermal dissipation capability of the area surrounding the device on a printed circuit board. This model is most useful for ceramic packages with heat sinks; some 90% of the heat flow is dissipated through the case to the heat sink and out to the ambient environment. For ceramic packages, in situations where the heat flow is split between a path to the case and an alternate path through the printed circuit board, analysis of the device thermal performance may need the additional modeling capability of a system level thermal simulation tool.

Preliminary Information

Design Considerations

Thermal Design Considerations

The thermal performance of plastic packages is more dependent on the temperature of the printed circuit board to which the package is mounted. Again, if the estimations obtained from $R_{\theta JA}$ do not satisfactorily answer whether the thermal performance is adequate, a system level model may be appropriate.

A complicating factor is the existence of three common ways for determining the junction-to-case thermal resistance in plastic packages:

- To minimize temperature variation across the surface, the thermal resistance is measured from the junction to the outside surface of the package (case) closest to the chip mounting area when that surface has a proper heat sink.
- To define a value approximately equal to a junction-to-board thermal resistance, the thermal resistance is measured from the junction to where the leads are attached to the case.
- If the temperature of the package case (T_T) is determined by a thermocouple, the thermal resistance is computed using the value obtained by the equation $(T_J - T_T)/P_D$.

As noted above, the junction-to-case thermal resistances quoted in this data sheet are determined using the first definition. From a practical standpoint, that value is also suitable for determining the junction temperature from a case thermocouple reading in forced convection environments. In natural convection, using the junction-to-case thermal resistance to estimate junction temperature from a thermocouple reading on the case of the package will estimate a junction temperature slightly hotter than actual temperature. Hence, the new thermal metric, Thermal Characterization Parameter or Ψ_{JT} , has been defined to be $(T_J - T_T)/P_D$. This value gives a better estimate of the junction temperature in natural convection when using the surface temperature of the package. Remember that surface temperature readings of packages are subject to significant errors caused by inadequate attachment of the sensor to the surface and to errors caused by heat loss to the sensor. The recommended technique is to attach a 40-gauge thermocouple wire and bead to the top center of the package with thermally conductive epoxy.

Preliminary Information

ELECTRICAL DESIGN CONSIDERATIONS

CAUTION

This device contains protective circuitry to guard against damage due to high static voltage or electrical fields. However, normal precautions are advised to avoid application of any voltages higher than maximum rated voltages to this high-impedance circuit. Reliability of operation is enhanced if unused inputs are tied to an appropriate logic voltage level (e.g., either GND or V_{CC}).

Use the following list of recommendations to assure correct DSP operation:

- Provide a low-impedance path from the board power supply to each V_{CC} pin on the DSP, and from the board ground to each GND pin.
- Use at least four 0.01–0.1 μF bypass capacitors positioned as close as possible to the four sides of the package to connect the V_{CC} power source to GND.
- Ensure that capacitor leads and associated printed circuit traces that connect to the chip V_{CC} and GND pins are less than 0.5 in per capacitor lead.
- Use at least a four-layer Printed Circuit Board (PCB) with two inner layers for V_{CC} and GND.
- Because the DSP output signals have fast rise and fall times, PCB trace lengths should be minimal. This recommendation particularly applies to the address and data buses as well as the $\overline{\text{IRQA}}$, $\overline{\text{IRQB}}$, and NMI pins. Maximum Printed Circuit Board (PCB) trace lengths on the order of 6 inches are recommended.
- Consider all device loads as well as parasitic capacitance due to PCB traces when calculating capacitance. This is especially critical in systems with higher capacitive loads that could create higher transient currents in the V_{CC} and GND circuits.
- All inputs must be terminated (i.e., not allowed to float) using CMOS levels, except as noted in **Section 1**.
- Take special care to minimize noise levels on the V_{CCP} and GND_P pins.
- If multiple DSP56011 devices are on the same board, check for cross-talk or excessive spikes on the supplies due to synchronous operation of the devices.

Preliminary Information

POWER CONSUMPTION CONSIDERATIONS

Power dissipation is a key issue in portable DSP applications. Some of the factors which affect current consumption are described in this section. Most of the current consumed by CMOS devices is Alternating Current (AC), which is charging and discharging the capacitances of the pins and internal nodes.

Current consumption is described by the formula:

Equation 3: $I = C \times V \times f$

where: C = node/pin capacitance
V = voltage swing
f = frequency of node/pin toggle

Example 4-1 Current Consumption

For an I/O pin loaded with 50 pF capacitance, operating at 5.5 V, and with a 81 MHz clock, toggling at its maximum possible rate (20 MHz), the current consumption is:

Equation 4: $I = 50 \times 10^{-12} \times 5.5 \times 20 \times 10^6 = 5.5\text{mA}$

The Maximum Internal Current ($I_{CCI\text{max}}$) value reflects the typical possible switching of the internal buses on best-case operation conditions, which is not necessarily a real application case. The Typical Internal Current ($I_{CCI\text{typ}}$) value reflects the average switching of the internal buses on typical operating conditions.

For applications that require very low current consumption:

- Minimize the number of pins that are switching.
- Minimize the capacitive load on the pins.
- Connect the unused inputs to pull-up or pull-down resistors.
- Disable unused peripherals.
- Disable unused pin activity.

Current consumption test code:

```
org      p:RESET
        jmp      MAIN
        org      p:MAIN
        movep    #$180000,x:$FFFD
        move     #0,r0
        move     #0,r4
        move     #0,r5
        move     #$00FF,m0
        move     #$00FF,m4
        nop
        rep      #256
        move     r0,x:(r0)+
        rep      #256
        mov      r4,y:(r4)+
        clr      a
        move     l:(r0)+,a
        rep      #30
        mac      x0,y0,a    x:(r0)+,x0    y:(r4)+,y0
        move     a,p:(r5)
        jmp      TP1
TP1     nop
        jmp      MAIN
```

POWER-UP CONSIDERATIONS

To power-up the device properly, ensure that the following conditions are met:

- Stable power is applied to the device according to the specifications in **Table 2-3** (DC Electrical Characteristics).
- The external clock oscillator is active and stable.
- $\overline{\text{RESET}}$ is asserted according to the specifications in **Table 2-7** (Reset, Stop, Mode Select, and Interrupt Timing).
- The following input pins are driven to valid voltage levels: $\overline{\text{DR}}$, PINIT , MODA , MODB , and MODC .

Care should be taken to ensure that the maximum ratings for all input voltages obey the restrictions on **Table 2-1** (Maximum Ratings), at all phases of the power-up procedure. This may be achieved by powering the external clock, hardware reset, and mode selection circuits from the same power supply that is connected to the power supply pins of the chip.

At the beginning of the hardware reset procedure, the device might consume significantly more current than the specified typical supply current. This is because of contentions among the internal nodes being affected by the hardware reset signal until they reach their final hardware reset state.

HOST PORT CONSIDERATIONS

Careful synchronization is required when reading multi-bit registers that are written by another asynchronous system. This is a common problem when two asynchronous systems are connected. The situation exists in the Host Interface. The following paragraphs present considerations for proper operation.

Host Programming Considerations

- **Unsynchronized Reading of Receive Byte Registers**—When reading receive byte registers, RXH or RXL, the host program should use interrupts or poll the RXDF flag which indicates that data is available. This assures that the data in the receive byte registers will be stable.
- **Overwriting Transmit Byte Registers**—The host program should not write to the transmit byte registers, TXH or TXL, unless the TXDE bit is set, indicating that the transmit byte registers are empty. This guarantees that the transmit byte registers will transfer valid data to the HRX register.
- **Synchronization of Status Bits from DSP to Host**—HC, $\overline{\text{HOREQ}}$, DMA, HF3, HF2, TRDY, TXDE, and RXDF status bits are set or cleared from inside the DSP and read by the host processor (refer to the *User's Manual* for descriptions of these status bits). The host can read these status bits very quickly without regard to the clock rate used by the DSP, but the state of the bit could be changing during the read operation. Generally, this is not a system problem, since the bit will be read correctly in the next pass of any host polling routine.

However, if the host asserts $\overline{\text{HEN}}$ for more than timing number 31, with a minimum cycle time of timing number 31 + 32, then these status bits are guaranteed to be stable. Exercise care when reading status bits HF3 and HF2 as an encoded pair. If the DSP changes HF3 and HF2 from 00 to 11, there is a small probability that the host could read the bits during the transition and receive 01 or 10 instead of 11. If the combination of HF3 and HF2 has significance, the host could read the wrong combination. Therefore, read the bits twice and check for consensus.

- **Overwriting the Host Vector**—The host program should change the Host Vector register only when the Host Command bit (HC) is clear. This change will guarantee that the DSP interrupt control logic will receive a stable vector.
- **Cancelling a Pending Host Command Exception**—The host processor may elect to clear the HC bit to cancel the host command exception request at any time before it is recognized by the DSP. Because the host does not know exactly when the exception will be recognized (due to exception processing synchronization and pipeline delays), the DSP may execute the host

Preliminary Information

command exception after the HC bit is cleared. For these reasons, the HV bits must not be changed at the same time that the HC bit is cleared.

- **Variance in the Host Interface Timing**—The Host Interface (HI) may vary (e.g. due to the PLL lock time at reset). Therefore, a host which attempts to load (bootstrap) the DSP should first make sure that the part has completed its HI port programming (e.g., by setting the INIT bit in ICR then polling it and waiting it to be cleared, then reading the ISR or by writing the TREQ/RREQ together with the INIT and then polling INIT, ISR, and the HOREQ pin).

DSP Programming Considerations

- **Synchronization of Status Bits from Host to DSP**—DMA, HF1, HF0, and HCP, HTDE, and HRDF status bits are set or cleared by the host processor side of the interface. These bits are individually synchronized to the DSP clock. (Refer to the *User's Manual* for descriptions of these status bits.)
- **Reading HF0 and HF1 as an Encoded Pair**—Care must be exercised when reading status bits HF0 and HF1 as an encoded pair, (i.e., the four combinations 00, 01, 10, and 11 each have significance). A very small probability exists that the DSP will read the status bits synchronized during transition. Therefore, HF0 and HF1 should be read twice and checked for consensus.



SECTION 5

ORDERING INFORMATION

Consult a Motorola Semiconductor sales office or authorized distributor to determine product availability and to place an order.

Table 5-1 Ordering Information

Part	Supply Voltage	Package Type	Pin Count	Frequency (MHz)	Order Number
DSPA56011	5 V	Thin Quad Flat Pack (TQFP)	100	95	XCA56011BU95
DSPB56011	5 V	Thin Quad Flat Pack (TQFP)	100	95	XCB56011BU95
<p>Note: The DSPA56011 and the DSPB56011 include factory-programmed ROM containing support for Dolby AC-3 with DVD specifications. These parts can be used only by customers licensed for Dolby AC-3. Future products in the DSP56011 family will include other ROM-based options. For additional information on future part development, or to request customer-specific ROM-based support, call your local Motorola Semiconductor sales office or authorized distributor.</p>					



Preliminary Information

OnCE, Mfax, and Symphony are trademarks of Motorola, Inc.



Motorola reserves the right to make changes without further notice to any products herein. Motorola makes no warranty, representation or guarantee regarding the suitability of its products for any particular purpose, nor does Motorola assume any liability arising out of the application or use of any product or circuit, and specifically disclaims any and all liability, including without limitation consequential or incidental damages. "Typical" parameters which may be provided in Motorola data sheets and/or specifications can and do vary in different applications and actual performance may vary over time. All operating parameters, including "Typicals" must be validated for each customer application by customer's technical experts. Motorola does not convey any license under its patent rights nor the rights of others. Motorola products are not designed, intended, or authorized for use as components in systems intended for surgical implant into the body, or other applications intended to support life, or for any other application in which the failure of the Motorola product could create a situation where personal injury or death may occur. Should Buyer purchase or use Motorola products for any such unintended or unauthorized application, Buyer shall indemnify and hold Motorola and its officers, employees, subsidiaries, affiliates, and distributors harmless against all claims, costs, damages, and expenses, and reasonable attorney fees arising out of, directly or indirectly, any claim of personal injury or death associated with such unintended or unauthorized use, even if such claim alleges that Motorola was negligent regarding the design or manufacture of the part. Motorola and  are registered trademarks of Motorola, Inc. Motorola, Inc. is an Equal Opportunity/Affirmative Action Employer.

How to reach us:

USA/Europe/Locations Not Listed:

Motorola Literature Distribution
P.O. Box 5405
Denver, Colorado 80217
303-675-2140
1 (800) 441-2447

Asia/Pacific:

Motorola Semiconductors H.K. Ltd.
8B Tai Ping Industrial Park
51 Ting Kok Road
Tai Po, N.T., Hong Kong
852-26629298

Japan:

Nippon Motorola Ltd.
SPD, Strategic Planning Office
4-32-1, Nishi-Gotanda
Shinagawa-ku, Tokyo 141, Japan
81-3-5487-8488

Mfax™:

RMFAX0@email.sps.mot.com
TOUCHTONE (602) 244-6609
US & Canada ONLY (800) 774-1848

Technical Resource Center:

1 (800) 521-6274

DSP Helpline

dsphelp@dsp.sps.mot.com

Internet:

<http://www.motorola-dsp.com>

