

# DATA SHEET

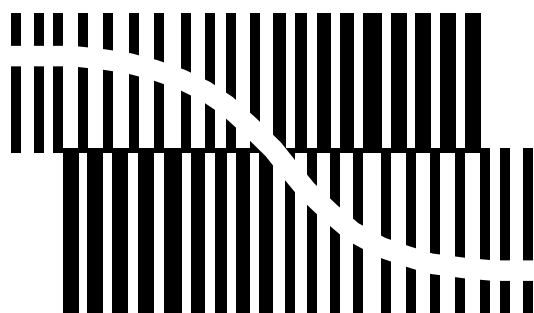

BITSTREAM CONVERSION

## **SAA7367**

Bitstream conversion ADC for  
digital audio systems

Product specification  
Supersedes data of 1996 Jun 17  
File under Integrated Circuits, IC01

1998 Nov 17

# Bitstream conversion ADC for digital audio systems

## SAA7367

### FEATURES

- Total Harmonic Distortion plus Noise (THD + N) = -88 dB (0.004%); DR = 93 dB; S/N = 97 dB
- Simple interfacing to analog inputs
- Small, non-critical PCB layout
- Low pin-out SO24 package (pin-compatible to SAA7366)
- 4 flexible serial interface modes
- 4.5 to 5.5 V operation
- Standby mode
- Detection of digital signal  $\geq -1$  dB amplitude
- Up to 18 significant bits serial output
- Selectable high-pass filter.

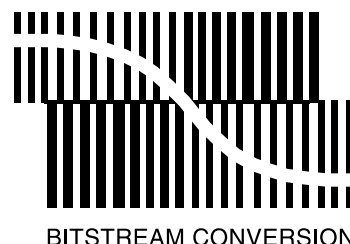

### GENERAL DESCRIPTION

The SAA7367 is a CMOS low-cost stereo Analog-to-Digital Converter (ADC) using the Philips bitstream conversion technique.

### APPLICATIONS

The device is designed for the digital acquisition of analog audio signals for digital audio systems such as:

- Compact Disc-Recordable (CD-R)
- Audio digital signal processing systems for hi-fi and musical instrument applications
- Digital Audio Tape (DAT).

### QUICK REFERENCE DATA

SYMBOL	PARAMETER	CONDITIONS	MIN.	TYP.	MAX.	UNIT
V <sub>DDD</sub>	digital supply voltage		4.5	5.0	5.5	V
I <sub>DDD</sub>	digital supply current		–	17	–	mA
V <sub>DDA</sub>	analog supply voltage		4.5	5.0	5.5	V
I <sub>DDA</sub>	analog supply current		–	13	–	mA
f <sub>BCK</sub>	clock input frequency		4.60	12.288	12.8	MHz
f <sub>s</sub>	sample rate		18	48	50	kHz
THD + N	total harmonic distortion plus noise	at 0 dB input	–	-88	-80	dB
DR	dynamic range	at -60 dB	90	93	–	dB
S/N	signal-to-noise ratio		–	97	–	dB

### ORDERING INFORMATION

TYPE NUMBER	PACKAGE		
	NAME	DESCRIPTION	VERSION
SAA7367	SO24	plastic small outline package; 24 leads; body width 7.5 mm	SOT137-1

# Bitstream conversion ADC for digital audio systems

SAA7367

## BLOCK DIAGRAM

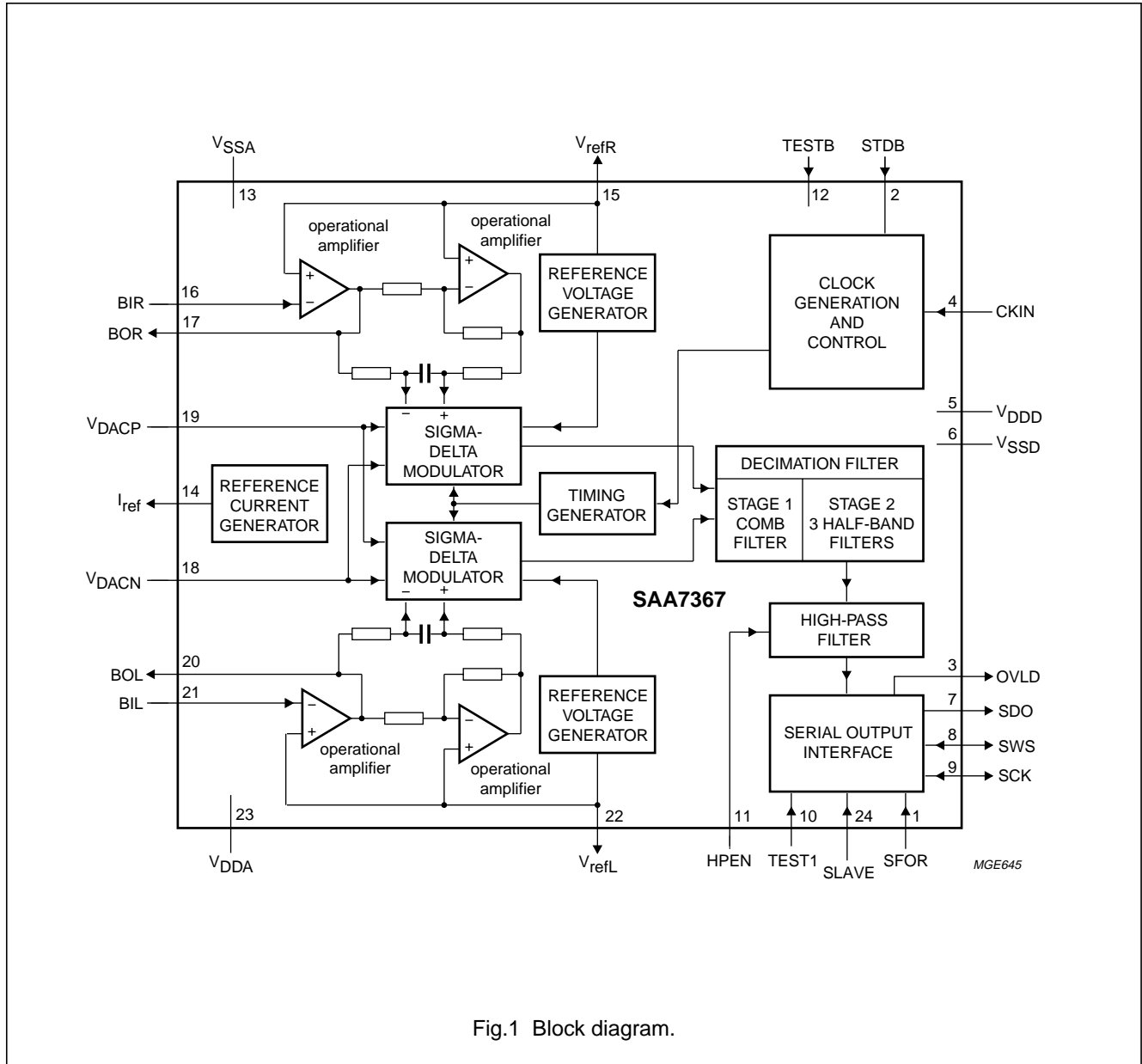

Fig.1 Block diagram.

# Bitstream conversion ADC for digital audio systems

SAA7367

## PINNING

SYMBOL	PIN	DESCRIPTION
SFOR	1	TTL level input; in normal mode this input selects the serial interface output format; output format is selected as follows: SFOR = HIGH selects Format 1 SFOR = LOW selects Format 2 (similar to I <sup>2</sup> S)
STDB	2	schmitt-trigger input; in normal mode, this input is used to select standby mode:
		STDB = HIGH selects normal operation
		STDB = LOW selects standby mode (low power consumption)
OVL	3	TTL level output; in normal mode this output indicates whether the internal digital signal is within 1 dB of maximum; if so, the output will go HIGH for 131072 clock cycles (approximately 11 ms); in standby mode this output is forced LOW
CKIN	4	CMOS level input; system clock input; nominally clocked at 256f <sub>s</sub>
V <sub>DDD</sub>	5	digital supply voltage (4.5 to 5.5 V)
V <sub>SSD</sub>	6	digital ground
SDO	7	TTL level output (3-state); in normal mode this pin outputs data from the serial interface; in standby mode, this output is high impedance
SWS	8	TTL level input/output; serial interface word select signal; in master mode (SLAVE = LOW), this pin outputs the serial interface word select signal; in slave mode (SLAVE = HIGH), this pin is the word select input to the serial interface; in standby mode (STDB = LOW) this pin is always an input (high impedance); for polarity: see Table 1
SCK	9	TTL level input/output; in master mode (SLAVE = LOW) the pin outputs the serial interface bit clock; in slave mode (SLAVE = HIGH) this pin is the input for the external bit clock; data on SDO is clocked out on the HIGH-to-LOW transition of SCK; the data is valid on the LOW-to-HIGH transition
TEST1	10	Test 1; TTL level input with internal pull-down; in slave mode (slave = HIGH), this pin is used to select extra serial interface formats (see Table 2)
HPEN	11	TTL level input; this input is used to enable the internal high-pass filter when HIGH; in scan-test mode (TESTB = LOW and TEST1 = LOW) this pin functions as 'scan chain c' input
TESTB	12	Test B; CMOS level input with internal pull-up; in normal applications, this input should be left HIGH
V <sub>SSA</sub>	13	analog ground; this pin is internally connected to V <sub>SS</sub> via the on-chip substrate contacts
I <sub>ref</sub>	14	current reference generator output; 33 kΩ in parallel with 22 nF is connected from this pin to V <sub>SSA</sub>
V <sub>refR</sub>	15	right channel analog reference output voltage ( $\frac{1}{2}V_{DDA}$ )
BIR	16	buffer operational amplifier inverting input for right channel
BOR	17	buffer operational amplifier output for right channel
V <sub>DACN</sub>	18	negative 1-bit DAC reference voltage input, connected to 0 V
V <sub>DACP</sub>	19	positive 1-bit DAC reference voltage input, connected to +5 V
BOL	20	buffer operational amplifier output for left channel
BIL	21	buffer operational amplifier inverting input for left channel
V <sub>refL</sub>	22	left channel analog reference output voltage ( $\frac{1}{2}V_{DDA}$ )
V <sub>DDA</sub>	23	analog supply voltage (4.5 to 5.5 V)

# Bitstream conversion ADC for digital audio systems

SAA7367

SYMBOL	PIN	DESCRIPTION
SLAVE	24	TTL level input; used to select the serial interface operating mode: SLAVE = HIGH selects slave mode SLAVE = LOW selects master mode

**Table 1** SWS polarity

CONDITIONS			POLARITY
SLAVE AND TEST1	SWS	SFOR	
SLAVE = LOW or TEST1 = LOW	LOW	LOW	left data
	LOW	HIGH	right data
SLAVE = HIGH and TEST1 = HIGH	LOW	LOW	right data
	LOW	HIGH	left data

**Table 2** Selection of serial interface formats via TEST1

CONDITIONS		SELECTED FORMAT
SFOR	TEST1	
HIGH	LOW	format 1
	HIGH	format 3
LOW	LOW	format 2
	HIGH	format 4

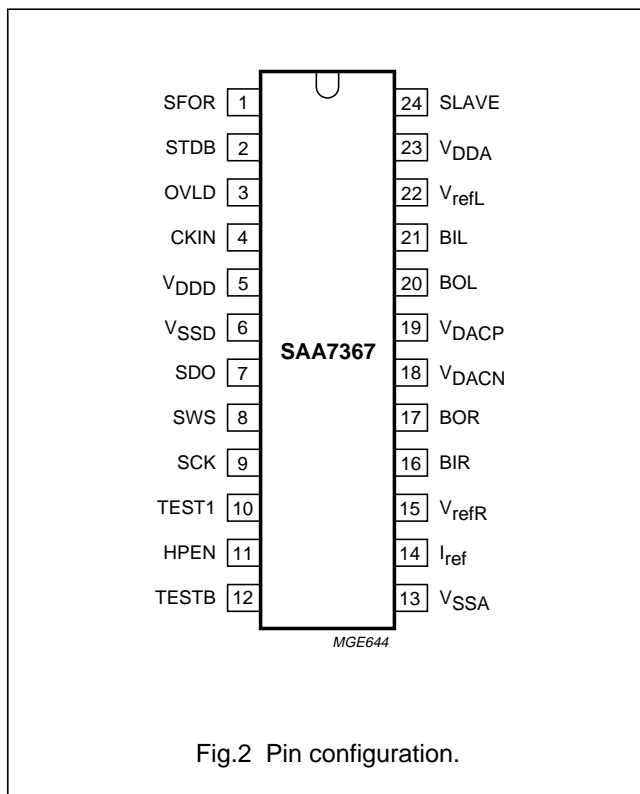

Fig.2 Pin configuration.

## FUNCTIONAL DESCRIPTION

### General

The SAA7367 is a bitstream conversion CMOS ADC for digital audio systems. The conversion is achieved using a third-order Sigma-Delta Modulator (SDM), running at 128 times the output sample frequency ( $f_s$ ). The high oversampling ratio greatly simplifies the design of the analog input anti-alias filter. In most events, the internal buffer operational amplifier, configured as a low-pass filter, will suffice. The 1-bit code from the SDM is filtered and down-sampled (decimated) to  $1f_s$  by Finite Impulse Response (FIR) filters. An optional  $I^2R$  high-pass filter is provided to remove DC, if required. The device has been designed with ease of use, low board area and low application costs in mind.

### Clock frequency

The external clock input on pin CKIN runs at  $256f_s$ , which can range from 18 to 50 kHz.

## Bitstream conversion ADC for digital audio systems

SAA7367

### Input buffer

Two input buffers are provided, one for each channel, for signal amplitude matching, signal buffering and anti-alias filter purposes. These are configured for inverting use. Access is provided by pins BIL, BIR (inverting inputs) and BOL, BOR (outputs), for left and right channels respectively. By the choice of feedback component values, the application signal amplitude can be matched to the requirements of the ADC.

Typically, the operational amplifiers are configured as low-pass filters with a gain of 1 and a pole at approximately  $5f_s$ .

**Remark:** the complete ADC is non-inverting. Hence, a positive DC input (referenced to  $V_{ref}$ ) will yield a positive digital output.

### Input level

The overall system gain is proportional  $V_{DDA}$ , or more accurately the potential difference between the DAC reference voltages ( $V_{VDACP}$ ) and ( $V_{VDACN}$ ). For convenience, the ADC input signal amplitude is defined as that amplitude seen on BOL or BOR, the operational amplifier outputs (i.e. the input to the SDM). Also, the 0 dB input level is defined as that which gives a  $-1$  dB (actually  $-1.12$  dB) digital output, relative to full-scale swing. This reduced gain provides headroom to accommodate small random DC offsets, without causing the digital output to clip.

Hence:

$$V_I (0 \text{ dB}) = \frac{(V_{VDACP} - V_{VDACN})}{5 \text{ V (RMS)}}$$

The user of the IC should ensure that, when all sources of signal amplitude variation are taken into account, the maximum input signal should conform to the 0 dB level. In the event that the maximum signal level cannot be pre-determined, e.g. live microphone input, the average signal level should be set at  $-10$  to  $-20$  dB down. The exact value will depend on the application and the balance between headroom and operating Signal-to-Noise Ratio (SNR).

### Behaviour during overload

As previously defined, the maximum input level for normal operation is 0 dB. If the input level exceeds this value, clipping may occur. Within the system, excessive amplitudes are detected after the high-pass filter. Infringements are limited to the maximum permitted positive or negative values  $2^{17} - 1$  or  $-2^{17}$  respectively.

Input signals in the range 0 to 1 dB may or may not be clipped, depending on the values of DC dither and small random offsets in the analog circuitry.

When using the recommended application circuitry, clipping will initially be observed on negative peaks, due to the use of negative DC dither.

The maximum level of overload that can be safely tolerated is application circuit dependent. In the case of the recommended circuit, the following applies: the inverting operational amplifier inputs BIL and BIR are protected from excessive voltages (currents) by diodes to  $V_{DDA}$  and  $V_{SSA}$ . These have absolute maximum ratings of  $I_d = \pm 20$  mA, with a safe practical limit of  $\pm 2$  mA.

Given the input resistor of  $10 \text{ k}\Omega$ ,  $\pm 2$  mA diode current and the operation of the operational amplifier, a maximum signal (applied to the input resistor) of  $\pm 30$  V can be handled safely. This level represents an overload of 26 dB.

During overload, the in-band portion of the waveform will be correctly converted. The out-of-band portion will be limited as previously detailed.

### Sigma-Delta Modulator (SDM)

The SAA7367 uses two third-order SDMs with a quantization noise floor of approximately  $-104$  dB. The scaling of the feedback has been optimized for stable operation, even during overload. Thus, with a maximum signal swing of 0 V to  $V_{DDA}$  on the input, the digital output remains well-behaved, i.e. it does not burst into random oscillation. During overload, the output is simply a clipped version of the input. The gain of this stage is  $-4.64$  dB.

### Decimation filter

Decimation from  $128f_s$  is performed in two stages. The first stage, a comb filter, uses 64 symmetrical coefficients to implement a  $3\text{rd } \sin^2/x$  characteristic. This filter decimates from 128 to  $8f_s$ . The second stage, an FIR filter, consists of three half-band filters, each decimating by a factor of 2. The overall characteristics are given in Table 3.

## Bitstream conversion ADC for digital audio systems

SAA7367

**Table 3** Overall filter characteristics

ITEM	CONDITION	VALUE (dB)
Pass band ripple	0 to $0.45f_s$	$\pm 0.1$
	$0.45$ to $0.47f_s$	$-0.5$
Stop band	$>0.55f_s$	$-60$
Dynamic range	0 to $0.42f_s$	110
Gain	DC	3.52

**High-pass filter**

An optional I<sup>2</sup>R high-pass filter is provided to remove unwanted DC components. The operation is selected when HPEN is HIGH and deselected when LOW. The filter has the characteristics given in Table 4.

**Table 4** High-pass filter characteristics

ITEM	CONDITION	VALUE (dB)
Pass band ripple		none
Pass band gain		0
Droop	at $0.00042f_s$	0.146
Attenuation at DC	at $0.00000036f_s$	$>40$
Dynamic range	0 to $0.45f_s$	$>110$

**Serial interface**

The serial interface provides 2 formats in master mode and 4 in slave mode (see Figs 3 and 4). Format 2 is similar to Philips I<sup>2</sup>S. In all modes, the interface provides up to 18 significant bits of output data per channel. During standby mode (STDB = LOW), all interface pins are in their high impedance state. On recovery from standby, the serial data output SDO is held LOW until valid data is available from the decimation filter. This time depends on whether the high-pass filter is selected:

HPEN = 0;  $T = 1024/f_s$ ,  $T = 21.3$  ms when  $f_s = 48$  kHz

HPEN = 1;  $T = 12288/f_s$ ,  $T = 256.0$  ms when  $f_s = 48$  kHz

**Overload detection**

The OVLD output is used to indicate when the output data, in either the left or right channel, is greater than  $-1$  dB (actual figure  $-1.023$  dB) of the maximum possible digital swing. When this condition is detected, the OVLD output is forced HIGH for at least  $512f_s$  cycles (10.6 ms at  $f_s = 48$  kHz). This time-out is reset for each infringement.

**Standby mode**

The STDB pin activates a power saving mode when the device function is not required. This pin can also be used as a chip enable.

On a HIGH-to-LOW transition of the STDB pin, the internal control circuitry starts a timed power-down sequence. This takes approximately 32 system clock cycles to complete. Transitions on STDB that are shorter than 32 clock cycles may have an indeterminate effect. However, the device will always recover correctly.

During standby, the following occurs:

- The internal logic clock is disabled
- The serial interface pins are forced to high impedance
- The OVLD output is forced LOW
- The analog circuitry is disabled
- The nominal external analog node voltages are maintained by a low-power circuit. This feature ensures a fast recovery from standby mode.

**Note:** since the serial interface pins are high impedance during standby, these pins could be wire-ORed with other serial interface ICs.

On a LOW-to-HIGH transition, the device reverts back to normal operation. This process takes approximately 256 system clock cycles. Before SDO is enabled, the output data is forced LOW. SDO remains LOW until good data is available from the decimation filter (see Section "Serial interface").

The STDB pin has a Schmitt-trigger input. A simple power-on-reset function can be effected using an external capacitor to  $V_{SS}$  and resistor to  $V_{DD}$ .

**TEST1**

This pin is used to select the serial interface format in slave mode.

# Bitstream conversion ADC for digital audio systems

SAA7367

## LIMITING VALUES

In accordance with the Absolute Maximum Rating System (IEC 134).

SYMBOL	PARAMETER	MIN.	MAX.	UNIT
$V_{DDA}$	analog supply voltage (note 1)	-0.5	+6.5	V
$V_I$	DC input voltage	-0.5	+6.5	V
$I_{IK}$	DC input clamp diode current	-	$\pm 20$	mA
$V_O$	DC output voltage	-0.5	$V_{DD} + 0.5$	V
$I_O$	DC output source or sink current	-	$\pm 20$	mA
$I_{DD(tot)}$	total DC supply current	-	$\pm 0.5$	A
$I_{SStot}$	total DC supply current	-	$\pm 0.5$	A
$T_{amb}$	operating ambient temperature	-40	+85	°C
$T_{stg}$	storage temperature	-65	+150	°C

### Note

- $V_{SSD}$  and  $V_{SSA}$  must be connected to a common potential.

## QUALITY SPECIFICATION

In accordance with "SNW-FQ-611-E". The number of the quality specification can be found in the "Quality Reference Handbook".

## CHARACTERISTICS

$V_{DDD} = 4.5$  to  $5.5$  V;  $V_{DDA} = 4.5$  to  $5.5$  V;  $f_s = 18$  to  $50$  kHz;  $T_{amb} = -40$  to  $+85$  °C; unless otherwise specified.

SYMBOL	PARAMETER	CONDITIONS	MIN.	TYP.	MAX.	UNIT
<b>Supplies</b>						
$V_{DDD}$	digital supply voltage		4.5	5	5.5	V
$I_{DDD}$	digital supply current	$f_s = 48$ kHz	-	17	-	mA
$V_{DDA}$	analog supply voltage		4.5	5	5.5	V
$I_{DDA}$	analog supply current		-	13	-	mA
$P_{tot}$	total power dissipation	$f_s = 48$ kHz	-	150	-	mW
$I_{stb}$	standby supply current		-	160	-	$\mu$ A
$P_{stb}$	standby power consumption		-	800	-	$\mu$ W
<b>Digital part: inputs</b>						
SFOR, SLAVE AND HPEN						
$V_{IL}$	LOW level input voltage		-0.5	-	+0.8	V
$V_{IH}$	HIGH level input voltage		2.0	-	$V_{DD} + 0.5$	V
$I_{LI}$	input leakage current		-10	-	+10	$\mu$ A
$C_i$	input capacitance		-	-	10	pF

# Bitstream conversion ADC for digital audio systems

SAA7367

SYMBOL	PARAMETER	CONDITIONS	MIN.	TYP.	MAX.	UNIT
<b>CKIN</b>						
V <sub>IL</sub>	LOW level input voltage		-0.5	-	0.3V <sub>DD</sub>	V
V <sub>IH</sub>	HIGH level input voltage		0.7V <sub>DD</sub>	-	V <sub>DD</sub> + 0.5	V
I <sub>LI</sub>	input leakage current		-10	-	+10	μA
C <sub>i</sub>	input capacitance		-	-	10	pF
<b>TEST1</b>						
V <sub>IL</sub>	LOW level input voltage		-0.5	-	+0.8	V
V <sub>IH</sub>	HIGH level input voltage		2.0	-	V <sub>DD</sub> + 0.5	V
R <sub>i</sub>	internal resistance to V <sub>SS</sub>		-	50	-	kΩ
C <sub>i</sub>	input capacitance		-	-	10	pF
<b>TESTB</b>						
V <sub>IH</sub>	HIGH level input voltage		0.7V <sub>DD</sub>	-	V <sub>DD</sub> + 0.5	V
R <sub>i</sub>	internal resistance to V <sub>DD</sub>		-	50	-	kΩ
<b>STDB (SCHMITT TRIGGER)</b>						
V <sub>IL</sub>	LOW level input voltage		-0.5	-	0.4V <sub>DD</sub>	V
V <sub>IH</sub>	HIGH level input voltage		0.6V <sub>DD</sub>	-	V <sub>DD</sub> + 0.5	V
V <sub>hys</sub>	hysteresis voltage		200	-	-	mV
I <sub>LI</sub>	input leakage current		-10	-	+10	μA
C <sub>i</sub>	input capacitance		-	-	10	pF
<b>Digital part: inputs/outputs</b>						
<b>SWS AND SCK</b>						
V <sub>IL</sub>	LOW level input voltage		-0.5	-	+0.8	V
V <sub>IH</sub>	HIGH level input voltage		2.0	-	V <sub>DD</sub> + 0.5	V
I <sub>LI</sub>	3-state leakage current		-10	-	+10	μA
C <sub>i</sub>	input capacitance		-	-	10	pF
V <sub>OL</sub>	LOW level output voltage	I <sub>O</sub> = -400 μA	-	-	0.4	V
V <sub>OH</sub>	HIGH level output voltage	I <sub>O</sub> = 20 μA	2.4	-	-	V
C <sub>L</sub>	output load capacitance	note 1	-	-	50	pF
<b>Digital part: outputs</b>						
<b>OVLD</b>						
V <sub>OL</sub>	LOW level output voltage	I <sub>O</sub> = -400 μA	-	-	0.4	V
V <sub>OH</sub>	HIGH level output voltage	I <sub>O</sub> = 20 μA	2.4	-	-	V
C <sub>L</sub>	output load capacitance	note 1	-	-	50	pF
<b>SDO</b>						
V <sub>OL</sub>	LOW level output voltage	I <sub>O</sub> = -400 μA	-	-	0.4	V
V <sub>OH</sub>	HIGH level output voltage	I <sub>O</sub> = 20 μA	2.4	-	-	V
I <sub>LI</sub>	3-state leakage current		-10	-	+10	μA
C <sub>L</sub>	output load capacitance	note 1	-	-	50	pF

# Bitstream conversion ADC for digital audio systems

SAA7367

SYMBOL	PARAMETER	CONDITIONS	MIN.	TYP.	MAX.	UNIT
<b>Digital part: timings</b>						
CKIN						
$t_r$	input rise time		–	–	10	ns
$t_f$	input fall time		–	–	10	ns
$f_i$	input frequency		4.60	–	12.8	MHz
msr	mark-to-space ratio	$f_s > 32$ kHz	40	–	60	%
		$f_s \leq 32$ kHz	30	–	70	%
<b>Serial Interface master and slave modes (see Figs 5 and 6)</b>						
SCK						
$t_r$	rise time	$C_L = 50$ pF; note 1	–	–	50	ns
$t_f$	fall time	$C_L = 50$ pF; note 1	–	–	50	ns
$t_L$	LOW time	$T = 1/64f_s$	0.4T	–	0.6T	ns
$t_H$	HIGH time	$T = 1/64f_s$	0.4T	–	0.6T	ns
$f_{clk}$	clock frequency	master mode	$64f_s$	$64f_s$	$64f_s$	MHz
		slave mode	–	–	$64f_s$	MHz
$t_{idle}$	burst clock idle time	slave mode; $T = 1/f_s$	0	–	0.5T	ns
SWS						
$t_r$	rise time	$C_L = 50$ pF; note 1	–	–	50	ns
$t_f$	fall time	$C_L = 50$ pF; note 1	–	–	50	ns
$t_L$	LOW time	$T = 1/f_s$	0.05T	0.5T	0.95T	ns
$t_H$	HIGH time	$T = 1/f_s$	0.05T	0.5T	0.95T	ns
$f_s$	frequency		$1f_s$	$1f_s$	$1f_s$	MHz
$t_d$	delay from SCK	master mode	–50	–	+50	ns
		slave mode	50	–	–	ns
$t_{su}$	set-up time to SCK	slave mode	150	–	–	ns
SDO						
$t_h$	data output hold time		100	–	–	ns
$t_{su}$	data output set-up time		50	–	–	ns
$t_r$	data output rise time	$C_L = 50$ pF; note 1	–	–	50	ns
$t_f$	data output fall time	$C_L = 50$ pF; note 1	–	–	50	ns

# Bitstream conversion ADC for digital audio systems

SAA7367

SYMBOL	PARAMETER	CONDITIONS	MIN.	TYP.	MAX.	UNIT
<b>Analog part at: <math>V_{DD} = V_{DDA} = 5\text{ V}</math>; <math>T_{amb} = 25\text{ °C}</math></b>						
$V_{refL}$ AND $V_{refR}$						
$V_O$	output voltage		$0.475V_{DDA}$	$0.5V_{DDA}$	$0.525V_{DDA}$	V
$R_{DC}$	DC impedance	normal mode	–	1.3	–	$k\Omega$
		standby mode	–	100	–	$k\Omega$
CURRENT REFERENCE: $I_{ref}$						
$V_O$	out put voltage		–	$0.5V_{DDA}$	–	V
$I_O$	output current	$R = 33\text{ k}\Omega$	–	76	–	$\mu\text{A}$
$V_{DACN}$						
$V_I$	input voltage		–	$V_{SS}$	–	V
$V_{DACP}$						
$V_I$	input voltage		–	$V_{DDA}$	–	V
BUFFER OPERATIONAL AMPLIFIERS: BIL, BOL, BIR AND BOR						
$V_{I(off)}$	input offset voltage		–	<10	–	mV
$R_L$	load resistance; (drive capability)	decoupled to $V_{ref}$	–	10	–	$k\Omega$
$Z_O$	output impedance		–	100	–	$\Omega$
THD + N	total harmonic distortion plus noise	$f = 0\text{ to }20\text{ kHz}$	–	–87	–	dB
OVERALL PERFORMANCE (ANALOG IN, DIGITAL OUT)						
$t_{gd}$	group delay time	$T = 1/f_s$	–	25T	–	s
$\alpha_{sb}$	stop band attenuation	$f > 0.546 f_s$	60	–	–	dB
DR	dynamic range	0 to 20 kHz	90	93	–	dB
THD + N	total harmonic distortion plus noise	0 to 20 kHz	–	–88	–80	dB
S/N	signal-to-noise ratio	A-weighted	–	97	–	dB
$\alpha_{CS}$	channel separation		–	92	–	dB
G	gain	note 2	–1.4	–1	–0.8	dB

**Notes**

1. Load capacitance is valid for master mode only.
2. See also Section “Input level” of Chapter “Functional description”; valid for left or right channel.

# Bitstream conversion ADC for digital audio systems

SAA7367

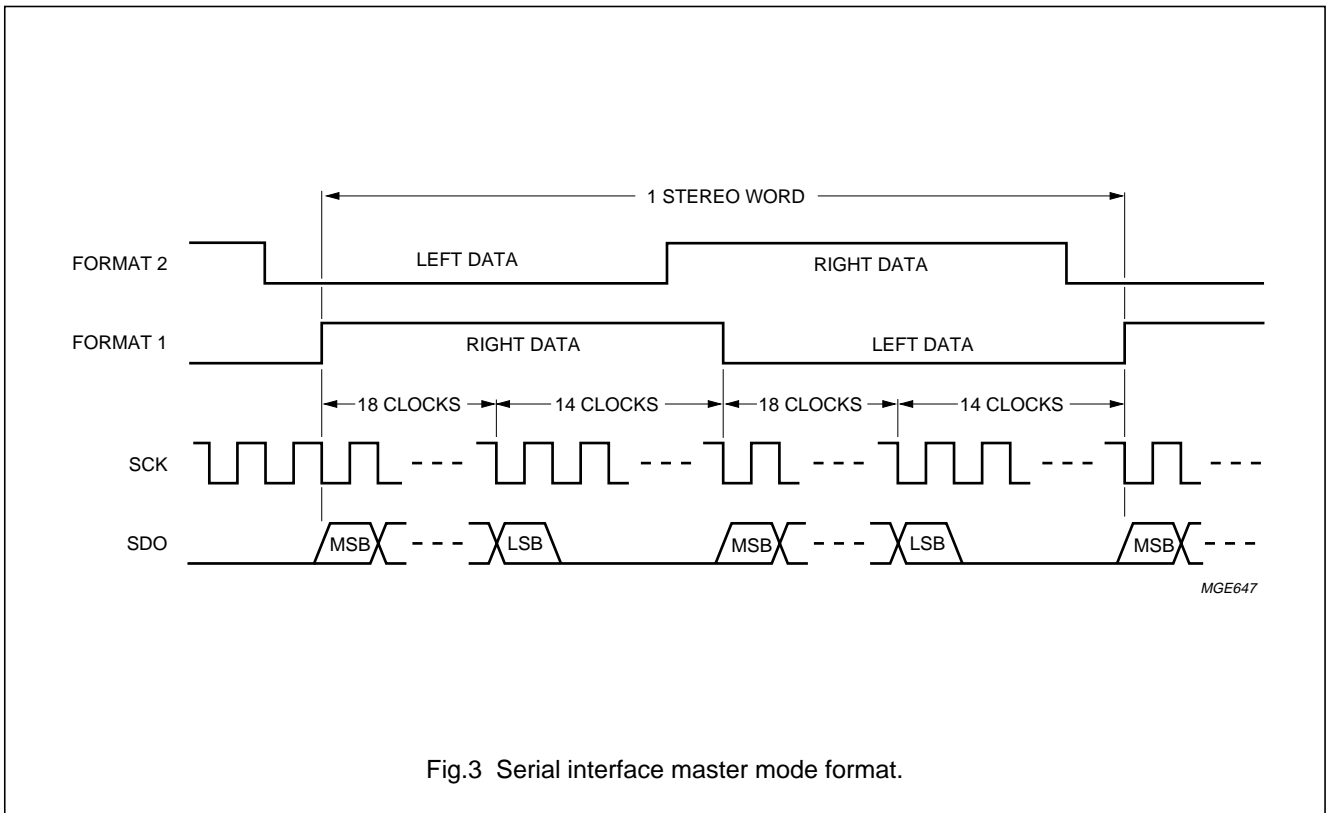

Fig.3 Serial interface master mode format.

# Bitstream conversion ADC for digital audio systems

SAA7367

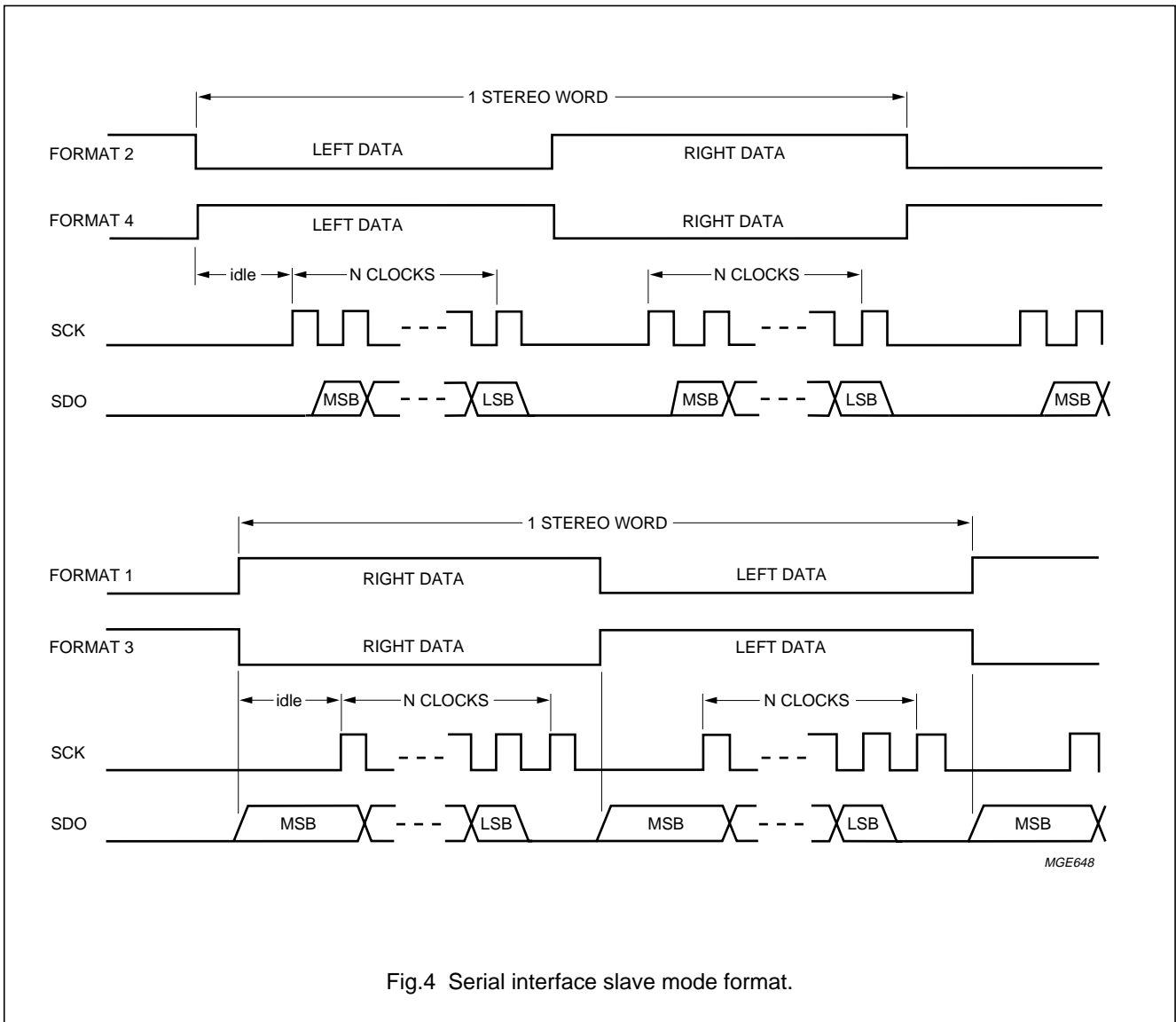
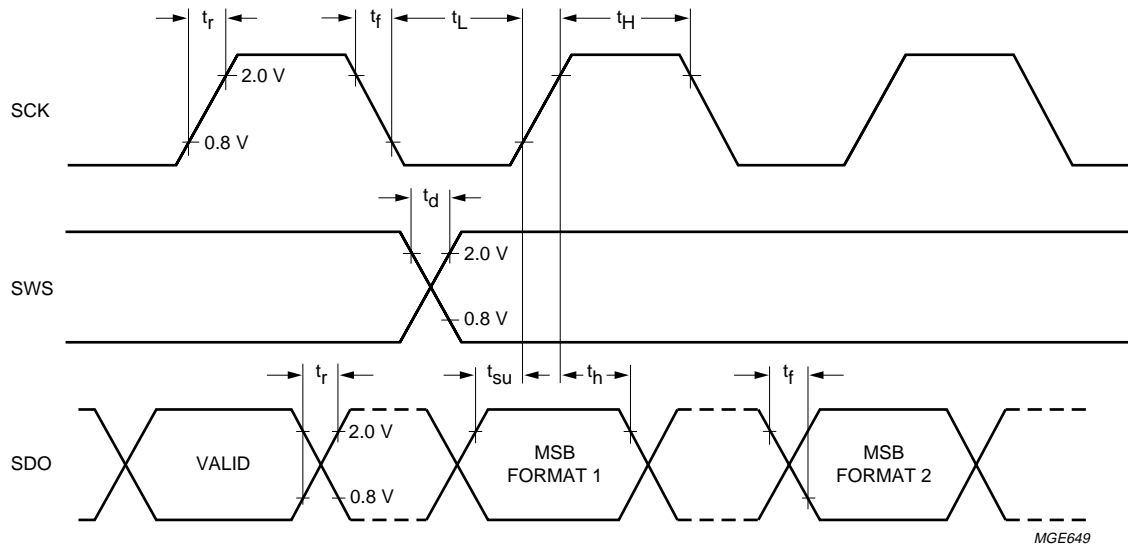

Fig.4 Serial interface slave mode format.

Bitstream conversion ADC for digital audio systems

SAA7367



MGE649

Fig.5 Serial interface master mode timing.

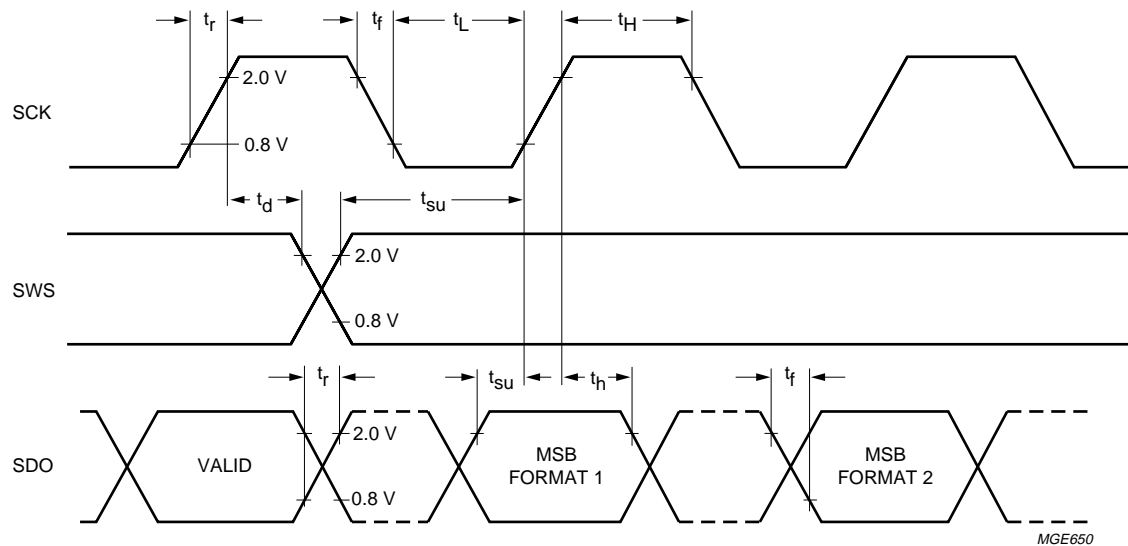

MGE650

Fig.6 Serial interface slave mode timing.

Bitstream conversion ADC for digital audio systems

SA A7367

APPLICATION INFORMATION

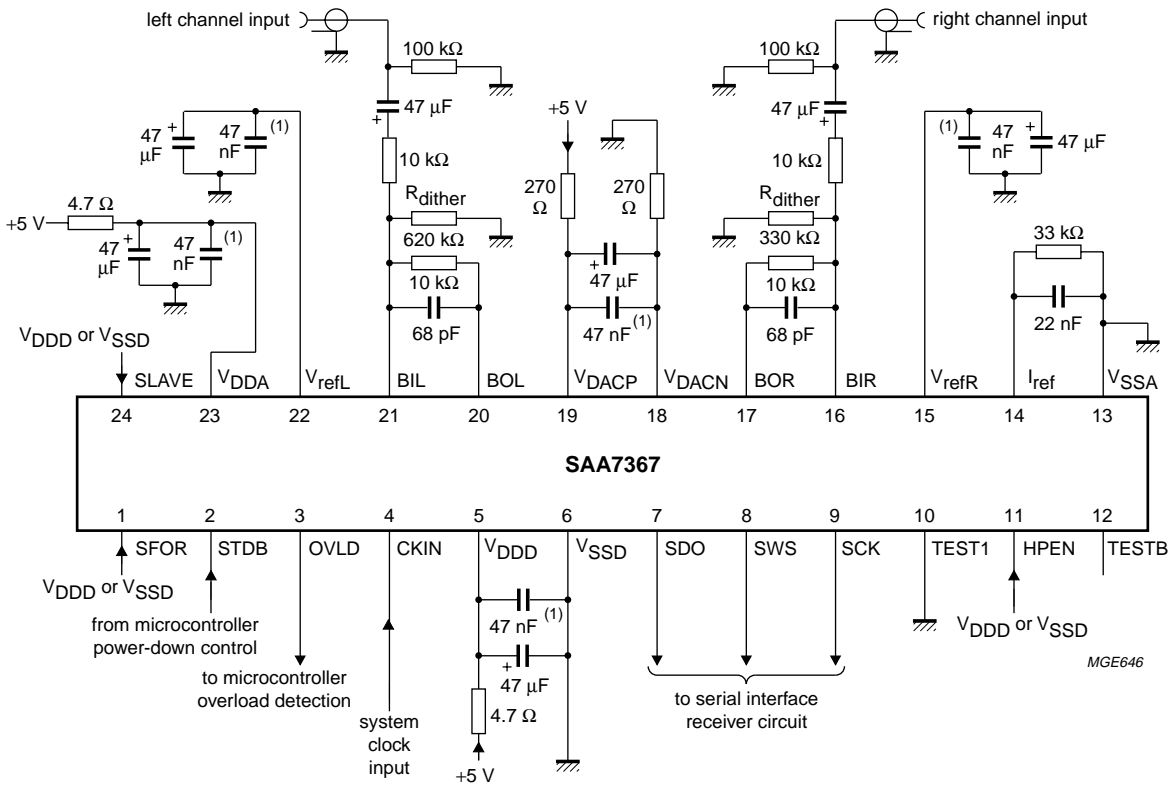

(1) These capacitors should preferably be surface-mounted components located as close as possible to the device pins.

Fig.7 Application circuit.

# Bitstream conversion ADC for digital audio systems

SAA7367

## PACKAGE OUTLINE

SO24: plastic small outline package; 24 leads; body width 7.5 mm

SOT137-1

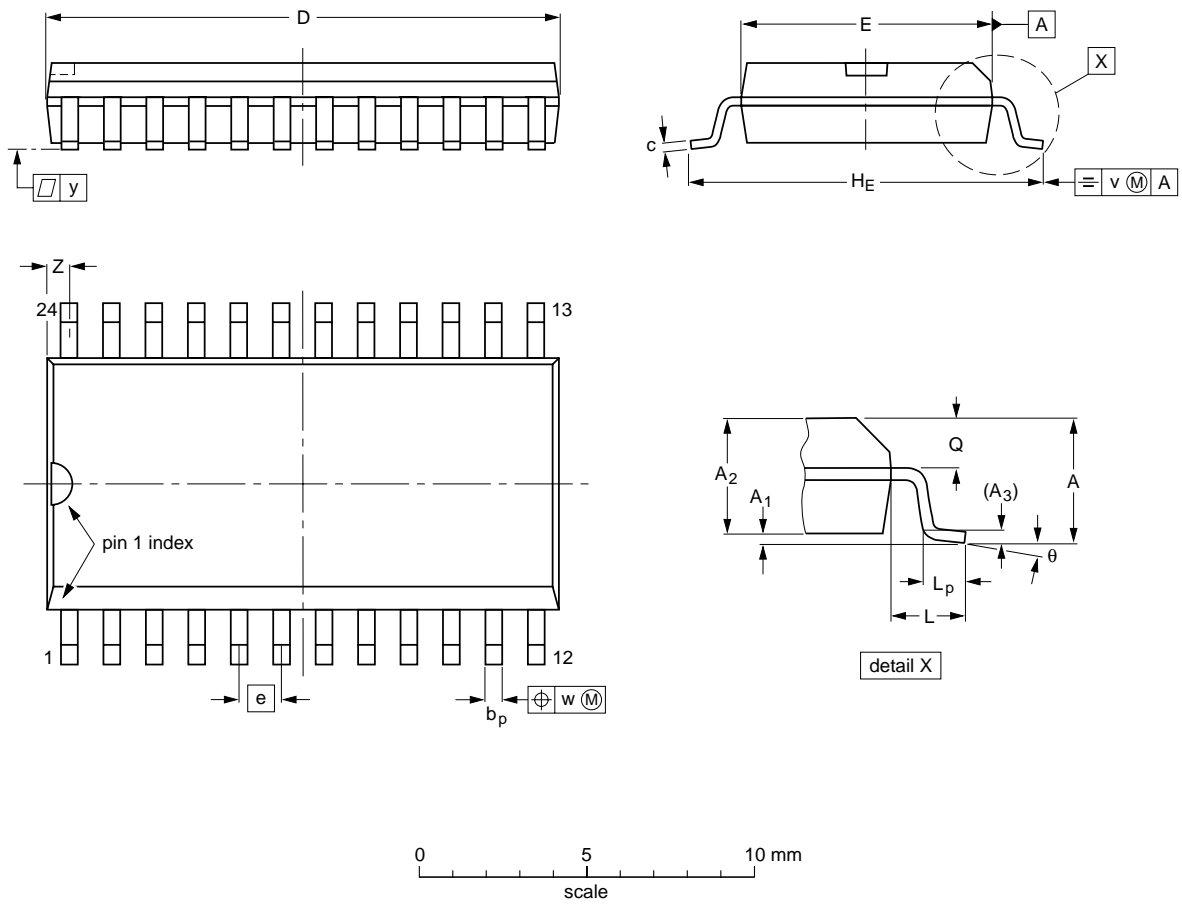

**DIMENSIONS (inch dimensions are derived from the original mm dimensions)**

UNIT	A max.	A <sub>1</sub>	A <sub>2</sub>	A <sub>3</sub>	b <sub>p</sub>	c	D <sup>(1)</sup>	E <sup>(1)</sup>	e	H <sub>E</sub>	L	L <sub>p</sub>	Q	v	w	y	Z <sup>(1)</sup>	θ
mm	2.65	0.30 0.10	2.45 2.25	0.25	0.49 0.36	0.32 0.23	15.6 15.2	7.6 7.4	1.27	10.65 10.00	1.4	1.1 0.4	1.1 1.0	0.25	0.25	0.1	0.9 0.4	8° 0°
inches	0.10	0.012 0.004	0.096 0.089	0.01	0.019 0.014	0.013 0.009	0.61 0.60	0.30 0.29	0.050	0.419 0.394	0.055	0.043 0.016	0.043 0.039	0.01	0.01	0.004	0.035 0.016	

**Note**

1. Plastic or metal protrusions of 0.15 mm maximum per side are not included.

OUTLINE VERSION	REFERENCES				EUROPEAN PROJECTION	ISSUE DATE
	IEC	JEDEC	EIAJ			
SOT137-1	075E05	MS-013AD				95-01-24 97-05-22

## Bitstream conversion ADC for digital audio systems

SAA7367

### SOLDERING

#### Introduction to soldering surface mount packages

This text gives a very brief insight to a complex technology. A more in-depth account of soldering ICs can be found in our *"Data Handbook IC26; Integrated Circuit Packages"* (document order number 9398 652 90011).

There is no soldering method that is ideal for all surface mount IC packages. Wave soldering is not always suitable for surface mount ICs, or for printed-circuit boards with high population densities. In these situations reflow soldering is often used.

#### Reflow soldering

Reflow soldering requires solder paste (a suspension of fine solder particles, flux and binding agent) to be applied to the printed-circuit board by screen printing, stencilling or pressure-syringe dispensing before package placement.

Several methods exist for reflowing; for example, infrared/convection heating in a conveyor type oven. Throughput times (preheating, soldering and cooling) vary between 100 and 200 seconds depending on heating method.

Typical reflow peak temperatures range from 215 to 250 °C. The top-surface temperature of the packages should preferably be kept below 230 °C.

#### Wave soldering

Conventional single wave soldering is not recommended for surface mount devices (SMDs) or printed-circuit boards with a high component density, as solder bridging and non-wetting can present major problems.

To overcome these problems the double-wave soldering method was specifically developed.

If wave soldering is used the following conditions must be observed for optimal results:

- Use a double-wave soldering method comprising a turbulent wave with high upward pressure followed by a smooth laminar wave.
- For packages with leads on two sides and a pitch (e):
  - larger than or equal to 1.27 mm, the footprint longitudinal axis is **preferred** to be parallel to the transport direction of the printed-circuit board;
  - smaller than 1.27 mm, the footprint longitudinal axis **must** be parallel to the transport direction of the printed-circuit board.

The footprint must incorporate solder thieves at the downstream end.
- For packages with leads on four sides, the footprint must be placed at a 45° angle to the transport direction of the printed-circuit board. The footprint must incorporate solder thieves downstream and at the side corners.

During placement and before soldering, the package must be fixed with a droplet of adhesive. The adhesive can be applied by screen printing, pin transfer or syringe dispensing. The package can be soldered after the adhesive is cured.

Typical dwell time is 4 seconds at 250 °C.

A mildly-activated flux will eliminate the need for removal of corrosive residues in most applications.

#### Manual soldering

Fix the component by first soldering two diagonally-opposite end leads. Use a low voltage (24 V or less) soldering iron applied to the flat part of the lead. Contact time must be limited to 10 seconds at up to 300 °C.

When using a dedicated tool, all other leads can be soldered in one operation within 2 to 5 seconds between 270 and 320 °C.

# Bitstream conversion ADC for digital audio systems

SAA7367

## Suitability of surface mount IC packages for wave and reflow soldering methods

PACKAGE	SOLDERING METHOD	
	WAVE	REFLOW <sup>(1)</sup>
HLQFP, HSQFP, HSOP, SMS	not suitable <sup>(2)</sup>	suitable
PLCC <sup>(3)</sup> , SO	suitable	suitable
LQFP, QFP, TQFP	not recommended <sup>(3)(4)</sup>	suitable
SQFP	not suitable	suitable
SSOP, TSSOP, VSO	not recommended <sup>(5)</sup>	suitable

### Notes

- All surface mount (SMD) packages are moisture sensitive. Depending upon the moisture content, the maximum temperature (with respect to time) and body size of the package, there is a risk that internal or external package cracks may occur due to vaporization of the moisture in them (the so called popcorn effect). For details, refer to the Drypack information in the "Data Handbook IC26; Integrated Circuit Packages; Section: Packing Methods".
- These packages are not suitable for wave soldering as a solder joint between the printed-circuit board and heatsink (at bottom version) can not be achieved, and as solder may stick to the heatsink (on top version).
- If wave soldering is considered, then the package must be placed at a 45° angle to the solder wave direction. The package footprint must incorporate solder thieves downstream and at the side corners.
- Wave soldering is only suitable for LQFP, TQFP and QFP packages with a pitch (e) equal to or larger than 0.8 mm; it is definitely not suitable for packages with a pitch (e) equal to or smaller than 0.65 mm.
- Wave soldering is only suitable for SSOP and TSSOP packages with a pitch (e) equal to or larger than 0.65 mm; it is definitely not suitable for packages with a pitch (e) equal to or smaller than 0.5 mm.

### DEFINITIONS

Data sheet status	
Objective specification	This data sheet contains target or goal specifications for product development.
Preliminary specification	This data sheet contains preliminary data; supplementary data may be published later.
Product specification	This data sheet contains final product specifications.
Limiting values	
Limiting values given are in accordance with the Absolute Maximum Rating System (IEC 134). Stress above one or more of the limiting values may cause permanent damage to the device. These are stress ratings only and operation of the device at these or at any other conditions above those given in the Characteristics sections of the specification is not implied. Exposure to limiting values for extended periods may affect device reliability.	
Application information	
Where application information is given, it is advisory and does not form part of the specification.	

### LIFE SUPPORT APPLICATIONS

These products are not designed for use in life support appliances, devices, or systems where malfunction of these products can reasonably be expected to result in personal injury. Philips customers using or selling these products for use in such applications do so at their own risk and agree to fully indemnify Philips for any damages resulting from such improper use or sale.

---

Bitstream conversion ADC for  
digital audio systems

---

SAA7367

**NOTES**

# Philips Semiconductors – a worldwide company

**Argentina:** see South America

**Australia:** 34 Waterloo Road, NORTH RYDE, NSW 2113, Tel. +61 2 9805 4455, Fax. +61 2 9805 4466

**Austria:** Computerstr. 6, A-1101 WIEN, P.O. Box 213, Tel. +43 160 1010, Fax. +43 160 101 1210

**Belarus:** Hotel Minsk Business Center, Bld. 3, r. 1211, Volodarski Str. 6, 220050 MINSK, Tel. +375 172 200 733, Fax. +375 172 200 773

**Belgium:** see The Netherlands

**Brazil:** see South America

**Bulgaria:** Philips Bulgaria Ltd., Energoproject, 15th floor, 51 James Bourchier Blvd., 1407 SOFIA, Tel. +359 2 689 211, Fax. +359 2 689 102

**Canada:** PHILIPS SEMICONDUCTORS/COMPONENTS, Tel. +1 800 234 7381

**China/Hong Kong:** 501 Hong Kong Industrial Technology Centre, 72 Tat Chee Avenue, Kowloon Tong, HONG KONG, Tel. +852 2319 7888, Fax. +852 2319 7700

**Colombia:** see South America

**Czech Republic:** see Austria

**Denmark:** Prags Boulevard 80, PB 1919, DK-2300 COPENHAGEN S, Tel. +45 32 88 2636, Fax. +45 31 57 0044

**Finland:** Sinikalliontie 3, FIN-02630 ESPOO, Tel. +358 9 615800, Fax. +358 9 61580920

**France:** 51 Rue Carnot, BP317, 92156 SURESNES Cedex, Tel. +33 1 40 99 6161, Fax. +33 1 40 99 6427

**Germany:** Hammerbrookstraße 69, D-20097 HAMBURG, Tel. +49 40 23 53 60, Fax. +49 40 23 536 300

**Greece:** No. 15, 25th March Street, GR 17778 TAVROS/ATHENS, Tel. +30 1 4894 339/239, Fax. +30 1 4814 240

**Hungary:** see Austria

**India:** Philips INDIA Ltd, Band Box Building, 2nd floor, 254-D, Dr. Annie Besant Road, Worli, MUMBAI 400 025, Tel. +91 22 493 8541, Fax. +91 22 493 0966

**Indonesia:** PT Philips Development Corporation, Semiconductors Division, Gedung Philips, Jl. Buncit Raya Kav.99-100, JAKARTA 12510, Tel. +62 21 794 0040 ext. 2501, Fax. +62 21 794 0080

**Ireland:** Newstead, Clonskeagh, DUBLIN 14, Tel. +353 1 7640 000, Fax. +353 1 7640 200

**Israel:** RAPAC Electronics, 7 Kehilat Saloniki St, PO Box 18053, TEL AVIV 61180, Tel. +972 3 645 0444, Fax. +972 3 649 1007

**Italy:** PHILIPS SEMICONDUCTORS, Piazza IV Novembre 3, 20124 MILANO, Tel. +39 2 6752 2531, Fax. +39 2 6752 2557

**Japan:** Philips Bldg 13-37, Kohnan 2-chome, Minato-ku, TOKYO 108-8507, Tel. +81 3 3740 5130, Fax. +81 3 3740 5077

**Korea:** Philips House, 260-199 Itaewon-dong, Yongsan-ku, SEOUL, Tel. +82 2 709 1412, Fax. +82 2 709 1415

**Malaysia:** No. 76 Jalan Universiti, 46200 PETALING JAYA, SELANGOR, Tel. +60 3 750 5214, Fax. +60 3 757 4880

**Mexico:** 5900 Gateway East, Suite 200, EL PASO, TEXAS 79905, Tel. +9-5 800 234 7381

**Middle East:** see Italy

**Netherlands:** Postbus 90050, 5600 PB EINDHOVEN, Bldg. VB, Tel. +31 40 27 82785, Fax. +31 40 27 88399

**New Zealand:** 2 Wagener Place, C.P.O. Box 1041, AUCKLAND, Tel. +64 9 849 4160, Fax. +64 9 849 7811

**Norway:** Box 1, Manglerud 0612, OSLO, Tel. +47 22 74 8000, Fax. +47 22 74 8341

**Pakistan:** see Singapore

**Philippines:** Philips Semiconductors Philippines Inc., 106 Valero St. Salcedo Village, P.O. Box 2108 MCC, MAKATI, Metro MANILA, Tel. +63 2 816 6380, Fax. +63 2 817 3474

**Poland:** Ul. Lukiska 10, PL 04-123 WARSZAWA, Tel. +48 22 612 2831, Fax. +48 22 612 2327

**Portugal:** see Spain

**Romania:** see Italy

**Russia:** Philips Russia, Ul. Usatcheva 35A, 119048 MOSCOW, Tel. +7 095 755 6918, Fax. +7 095 755 6919

**Singapore:** Lorong 1, Toa Payoh, SINGAPORE 319762, Tel. +65 350 2538, Fax. +65 251 6500

**Slovakia:** see Austria

**Slovenia:** see Italy

**South Africa:** S.A. PHILIPS Pty Ltd., 195-215 Main Road Martindale, 2092 JOHANNESBURG, P.O. Box 7430 Johannesburg 2000, Tel. +27 11 470 5911, Fax. +27 11 470 5494

**South America:** Al. Vicente Pinzon, 173, 6th floor, 04547-130 SÃO PAULO, SP, Brazil, Tel. +55 11 821 2333, Fax. +55 11 821 2382

**Spain:** Balmes 22, 08007 BARCELONA, Tel. +34 93 301 6312, Fax. +34 93 301 4107

**Sweden:** Kottbygatan 7, Akalla, S-16485 STOCKHOLM, Tel. +46 8 5985 2000, Fax. +46 8 5985 2745

**Switzerland:** Allmendstrasse 140, CH-8027 ZÜRICH, Tel. +41 1 488 2741 Fax. +41 1 488 3263

**Taiwan:** Philips Semiconductors, 6F, No. 96, Chien Kuo N. Rd., Sec. 1, TAIPEI, Taiwan Tel. +886 2 2134 2865, Fax. +886 2 2134 2874

**Thailand:** PHILIPS ELECTRONICS (THAILAND) Ltd., 209/2 Sanpavuth-Bangna Road Prakanong, BANGKOK 10260, Tel. +66 2 745 4090, Fax. +66 2 398 0793

**Turkey:** Talatpasa Cad. No. 5, 80640 GÜLTEPE/ISTANBUL, Tel. +90 212 279 2770, Fax. +90 212 282 6707

**Ukraine:** PHILIPS UKRAINE, 4 Patrice Lumumba str., Building B, Floor 7, 252042 KIEV, Tel. +380 44 264 2776, Fax. +380 44 268 0461

**United Kingdom:** Philips Semiconductors Ltd., 276 Bath Road, Hayes, MIDDLESEX UB3 5BX, Tel. +44 181 730 5000, Fax. +44 181 754 8421

**United States:** 811 East Arques Avenue, SUNNYVALE, CA 94088-3409, Tel. +1 800 234 7381

**Uruguay:** see South America

**Vietnam:** see Singapore

**Yugoslavia:** PHILIPS, Trg N. Pasica 5/v, 11000 BEOGRAD, Tel. +381 11 625 344, Fax. +381 11 635 777

**For all other countries apply to:** Philips Semiconductors, International Marketing & Sales Communications, Building BE-p, P.O. Box 218, 5600 MD EINDHOVEN, The Netherlands, Fax. +31 40 27 24825

**Internet:** <http://www.semiconductors.philips.com>

© Philips Electronics N.V. 1998

SCA60

All rights are reserved. Reproduction in whole or in part is prohibited without the prior written consent of the copyright owner.

The information presented in this document does not form part of any quotation or contract, is believed to be accurate and reliable and may be changed without notice. No liability will be accepted by the publisher for any consequence of its use. Publication thereof does not convey nor imply any license under patent- or other industrial or intellectual property rights.

Printed in The Netherlands

545102/00/02/pp20

Date of release: 1998 Nov 17

Document order number: 9397 750 04775

*Let's make things better.*

**Philips  
Semiconductors**



**PHILIPS**