

PREPARED BY: <i>S. Kamoshita</i>	DATE: <i>Jun/8/1999</i>	SHARP	SPEC.No: <i>DG-996011</i>
APPROVED BY: <i>M. Omote</i>	DATE: <i>Jun/8/99</i>		ISSUE: <i>Jun/8/99</i>
ELECTRONIC COMPONENTS GROUP SHARP CORPORATION			PAGE: <i>14 pages</i>
SPECIFICATION			REPRESENTATIVE DIVISION: Opto-Electronic Devices Division

DEVICE SPECIFICATION FOR
Light Emitting Diode

MODEL No.
LT1ZE40A

1. These specification sheets include materials protected under the copyright of Sharp Corporation ("Sharp"). Please do not reproduce or cause anyone to reproduce them without Sharp's consent.
2. When using this product, please observe the absolute maximum ratings and the instructions for use outlined in these specification sheets, as well as the precautions mentioned below. Sharp assumes no responsibility for any damage resulting from use of the product which does not comply with the absolute maximum ratings and the instructions included in these specification sheets, and the precautions mentioned below.

(Precautions)

 - (1) This products is designed for use in the following application areas;

- * OA equipment * Audio visual equipment * Home appliance
 - * Telecommunication equipment (Terminal) * Measuring equipment
 - * Tooling machines * Computers

If the use of the product in the above application areas is for equipment listed in paragraphs (2) or (3), please be sure to observe the precautions given in those respective paragraphs.
 - (2) Appropriate measures, such as fail-safe design and redundant design considering the safety design of the overall system and equipment, should be taken to ensure reliability and safety when this product is used for equipment which demands high reliability and safety in function and precision, such as ;

- * Transportation control and safety equipment (aircraft, train, automobile etc.)
 - * Traffic signals * Gas leakage sensor breakers * Rescue and security equipment
 - * Other safety equipment
 - (3) Please do not use this product for equipment which require extremely high reliability and safety in function and precision, such as ;

- * Space equipment * Telecommunication equipment (for trunk lines)
 - * Nuclear power control equipment * Medical equipment
 - (4) Please contact and consult with a Sharp sales representative if there are any questions regarding interpretation of the above three paragraphs.
3. Please contact and consult with a Sharp sales representative for any questions about this product.

CUSTOMER'S APPROVAL

DATE: _____

BY: _____

DATE: *Jun/8/1999*
 PRESENTED BY: *M. Katoh*

 M.Katoh,
 Department General Manager of
 Engineering Dept.,III
 Opto-Electronic Devices Division
 Electronic Components Group
 SHARP CORPORATION

DG-996011	Feb/22/99
MODEL No.	PAGE
LT1ZE40A	1/14

SHARP

LT1ZE40A Specification

1. Application

This specification applies to the light emitting diode device Model No. LT1ZE40A.
 [AlInGaP (dicing or scribe/brake type / Yellow green) chip LED device]

2. Outline dimensions and terminal connections Refer to the attached sheet Page 2.

3. Ratings and characteristics Refer to the attached sheet Page 3~5.

- 3-1. Absolute maximum ratings
- 3-2. Electro-optical characteristics
- 3-3. Derating Curve
- 3-4. Characteristics Diagram

4. Reliability Refer to the attached sheet Page 6.

- 4-1. Test items and test conditions
- 4-2. Failure judgement criteria

5. Incoming inspection Refer to the attached sheet Page 7.

- 5-1. Inspection method
- 5-2. Description of inspection and criteria

6. Taping specification Refer to the attached sheet Page 8~11.

- 6-1. Taping
- 6-2. Label
- 6-3. Luminous intensity rank
- 6-4. Dominant wavelength rank

7. Packing Specification Refer to the attached sheet Page 12.

- 7-1. Dampproof package
- 7-2. Storage conditions
- 7-3. Treatment after opening

8. Soldering Refer to the attached sheet Page 13.

- 8-1. Reflow soldering
- 8-2. Manual soldering

9. Precautions for use Refer to the attached sheet Page 14.

- 9-1. Precautions matters for designing circuit
- 9-2. Cleaning method

10. Environment Refer to the attached sheet Page 14.

- 10-1. Ozonosphere destructive chemicals.
- 10-2. Bromic non-burning materials

SHARP

2. Outline dimensions and terminal connections

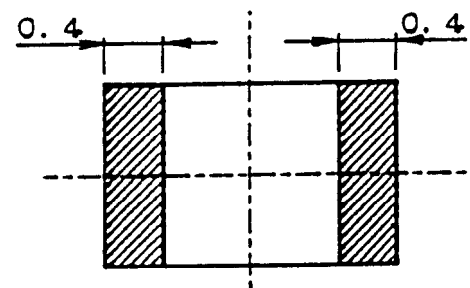
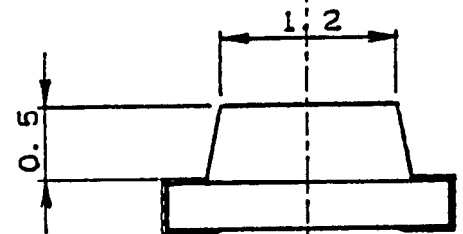
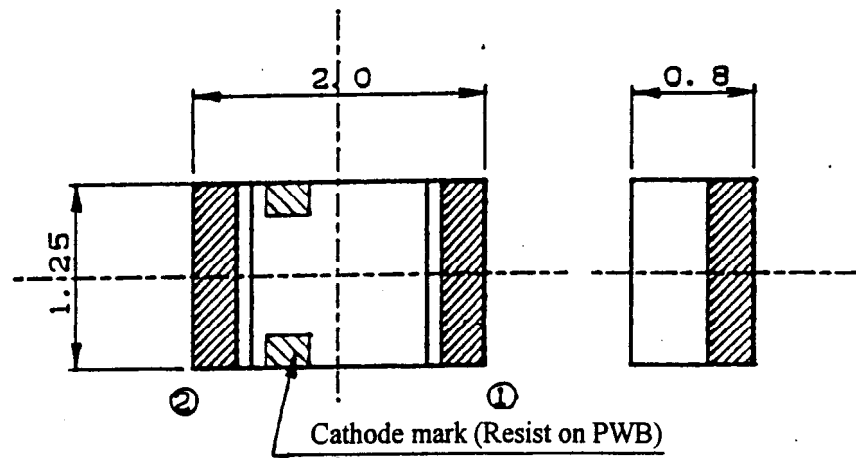

- 1. Plated area
- Resist area
- 2. Pin Connection
 - ① Cathode
 - ② Anode
 -

3. Unspecified tol. to be ± 0.1

Unit	Material	Finish	Drawing No.
mm	PWB: Glass-Epoxy Resin: Epoxy	Au Plated	

SHARP

3. Ratings and characteristics

3-1. Absolute maximum ratings

Parameter	Symbol	Rating	Unit	
Power dissipation	P	78	mW	
Continuous forward current	I_F	30	mA	
Peak forward current(Note 1)	I_{FM}	50	mA	
Derating factor	DC	-	0.4	mA/°C
	Pulse	-	0.67	mA/°C
Reverse voltage	V_R	5	V	
Operating temperature	T_{opr}	-30 ~ 85	°C	
Storage temperature	T_{stg}	-40 ~ 100	°C	
Soldering temperature(Note 2)	T_{sol}	350	°C	

(Note1) Duty ratio=1/10,Pulse width=0.1ms

(Note2) Manual soldering Max.3second

3-2. Electro-optical characteristics

($T_a=25^\circ\text{C}$)

Parameter	Symbol	Conditions *2	MIN.	TYP.	MAX.	Unit
Forward voltage	V_F	$I_F=20\text{mA}$	-	2.1	2.6	V
Luminous intensity (Note 3)	I_v		10	28.2	-	mc
Peak emission wavelength	λ_p		-	570	-	nm
Dominant wavelength	λ_d		-	570	-	nm
Spectrum radiation bandwidth	$\Delta\lambda$		-	15	-	nm
Reverse current	I_R	$V_R=4\text{V}$	-	-	100	μA
Terminal capacitance	C_t	$V=0\text{V}, f=1\text{MHz}$	-	60	-	pF

(Note 3) Measured by SHARP EG&G MODEL550(Radiometer/Photometersystem)

(Tolerance: $\pm 15\%$)

SHARP

3-3. Derating Curve

Forward Current Derating Curve

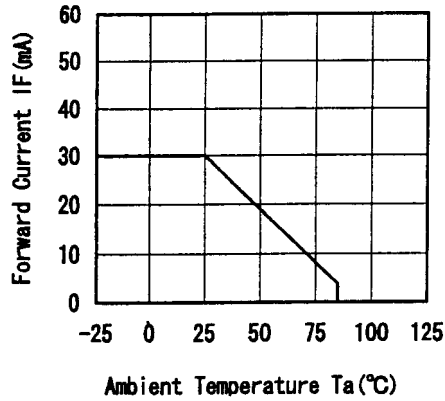

Peak Forward Current Derating Curve

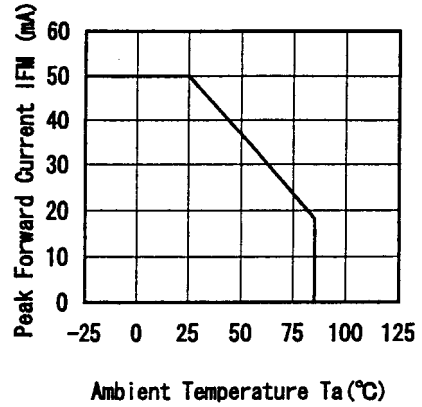

Peak Forward Current vs. Duty Ratio
($T_a=25^\circ\text{C}$)

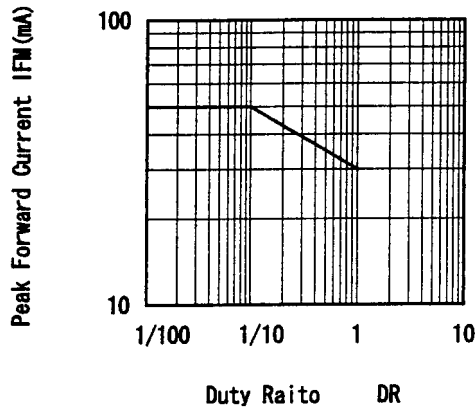

SHARP

3-4. Characteristics Diagram(typ) (Note 1)

Forward Current vs. Forward Voltage

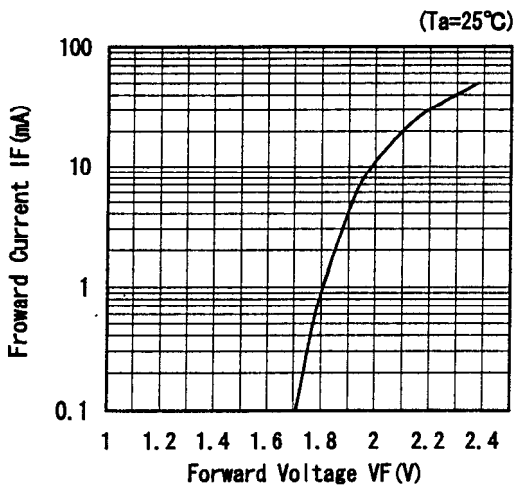

Relative Luminous Intensity vs. Ambient Temperature

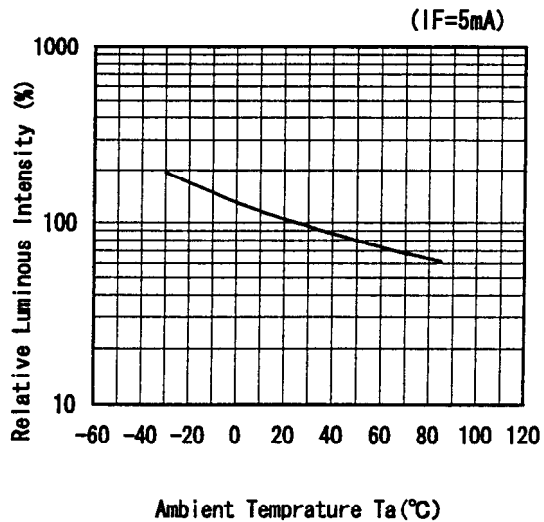

Relative Luminous Intensity vs. Forward Voltage

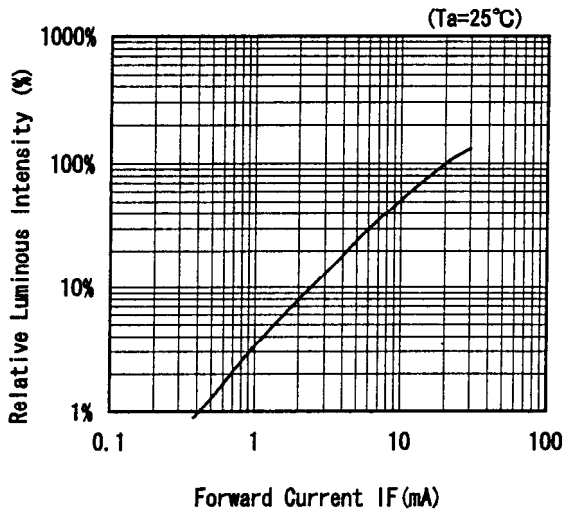

(Note 1) Above characteristic data are typical data and not a guaranteed data.

SHARP

4. Reliability

The reliability of products shall be satisfied with items listed below.

4-1. Test items and test conditions

Confidence level: 90%

Test items	Test conditions	Samples (n) Defective (C)	LTPD (%)
temperature cycling	-40°C(30min)~+100°C(30min),30times	n=22, C=0	10
High temp. and high humidity storage	Ta=+60°C, 90%RH, t=500h	n=22, C=0	10
High temperature storage	Ta=100°C, t=500h	n=22, C=0	10
Low temperature storage	Ta=-40°C, t=500h	n=22, C=0	10
Operating test	Ta=25°C, I _F =30mA, t=500h	n=22, C=0	10
Mechanical shock	15 000m/s ² , 0.5ms, 3times / ±X, ±Y, ±Z direction	n=11, C=0	20
Variable frequency vibration	200m/s ² , 100~2 000~100Hz/sweepfor 4min. ,4times/X, Y, Z direction	n=11, C=0	20
Soldering heat	Refer to the attached sheet, Page 13/14 2time	n=11, C=0	20

4-2. Failure judgement criteria *1

Parameter	Symbol	Failure judgement criteria *2
Forward voltage	V _F	V _F > U.S.L. × 1.2
Reverse current	I _R	I _R > U.S.L. × 2.0
Luminous intensity	I _v	I _v > The first stage value × 2.0 or The first stage value × 0.5 > I _v

*1: Measuring condition is in accordance with specification.

*2: U.S.L. is shown by Upper Specification Limit.

SHARP

5. Incoming inspection

5-1. Inspection method

A single sampling plan, normal inspection level S-4 based on ISO 2859-1 shall be adopted.

5-2. Description of inspection and criteria

No.	Inspection items	Criteria	Defect	AQL
1	Electro-optical characteristics	Not radiation	Major defect	0.1%
2	Radiation color	Not correct		
3	Taping	Product inserted in reverse direction		
4	Label	Model number is not printed, or misprinted		
5	Electrode plating	Plating abnormality observed over 50% or greater percentage *1		
6	Electro-optical characteristics	Not conforming to the specification	Minor defect	0.4%
7	Outline dimensions	Not conforming to the specification		
8	Dust and flaw	Effect to the specification		
9	Resin flash	Over the unspecified tolerance		
10	Resin crack	0.3mm or greater from the product side face		
11	Solderability	could solder 50% or greater and less than 90% out of judgement area *1		

*1 Judgement area : The plated area of the product bottom

SHARP

6. Taping specification

6-1. Taping

6-1-1. Shape and dimension of tape(TYP.)

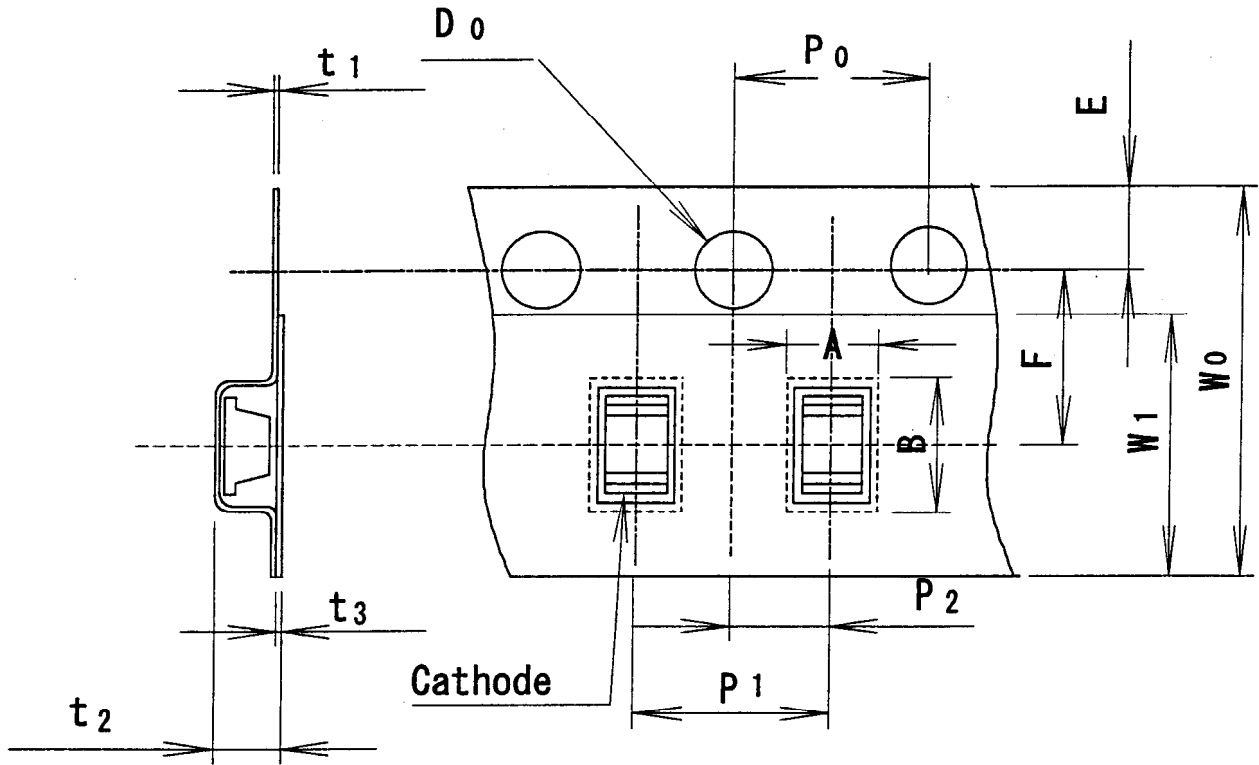

Parameter	Symbol	Dimension [mm](TYP.)	Remarks	
Concave square hole for part insertion	Vertical	A	1.55	Dimension excludes corner R at inside bottom
	Horizontal	B	2.3	
	Pitch	P_1	4.0	
Round sprocket hole	Diameter	D_0	1.5	
	Pitch	P_0	4.0	Accumulated error $\pm 0.5\text{mm}/10$ pitch
	Position	E	1.75	Distance between tape edge and hole center
Center to center dimension	Vert. dire	P_2	2.0	Center line of the concave square hole and round sprocket hole
	Hori. dire	F	3.5	
Cover tape	Width	W_1	5.5	
	Thickness	t_3	0.1	
Carrier tape	Width	W_0	8.0	
	Thickness	t_1	0.2	
Thickness of the entire unit		t_2	1.2	With cover tape and carrier tape combined

※ Material : Carrier tape...PS, Cover tape...Polyester

SHARP

6-1-2. Shape and dimension of reel(TYP.)

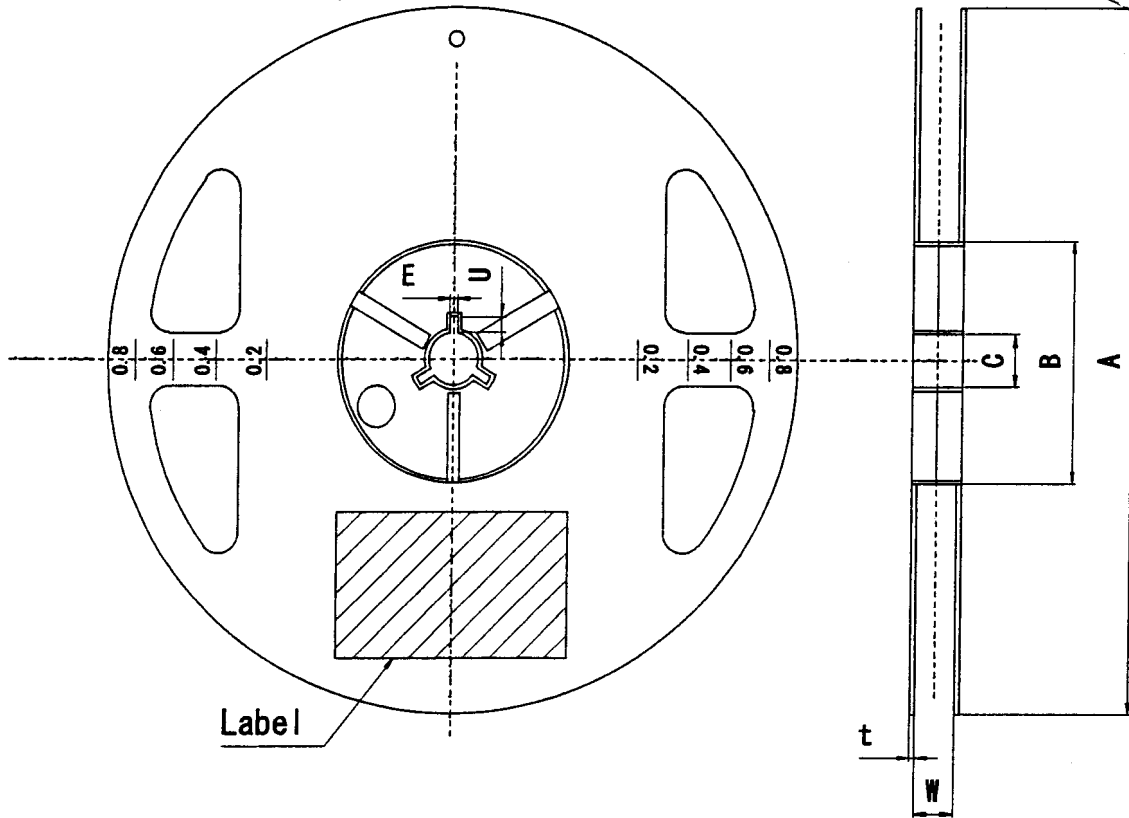

Parameter		Symbol	Dimension [mm](TYP.)	Remarks
Frange	Diameter	A	$\phi 178$	
	Thickness	t	1.5	
	Inner space direction	W	10	Dimension of shaft core
Hub	External diameter	B	$\phi 60$	
	Spindle hole diameter	C	$\phi 13$	
	Key slit	Width E Depth U	2.0 4.5	
Notation for part name etc.		Labeling on one side of flange.(part name,quantity,lot No.)		

※ Material : Reel...Polystyrene

SHARP

6-1-3. Taping specification

(1) Lead tape:

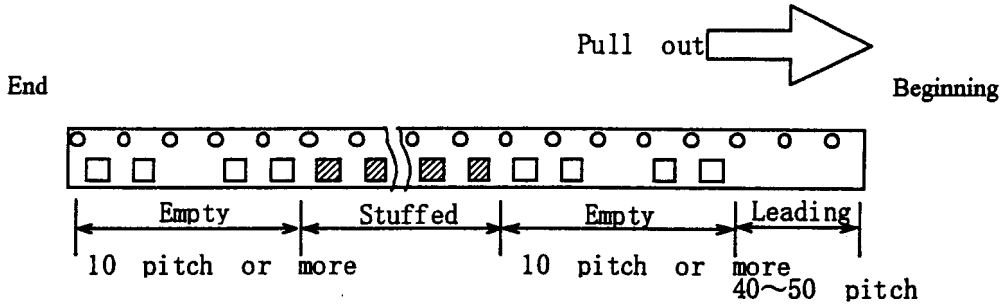

(2) Cover tape strength against peeling: $F=0.1\sim 0.8N$ ($\theta = 10^\circ$ or less)

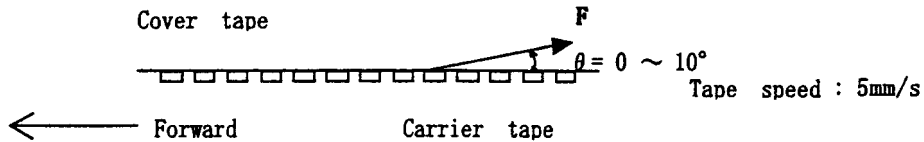

(3) Tape strength against bending:

The radius of bending circle should be 30mm or more.

If it is less than 30mm, the cover may peel.

(4) Jointing of tape: There should not be joint of cover tape or carrier tape.

(5) Quantity per reel: Average 4,000pcs. per reel

- (6) Others:
- ① There should not be missing above continuous three products.
 - ② Products should be easily taken out.
 - ③ Products should not be attached to the cover tape at peeling.

SHARP

6-2. Label

SHARP CORPORATION		
PART No.	LT1ZE40A	← Model number
QUANTITY	4000	← Quantity of products
		← EIAJ C-3 Bar code
		← EIAJ C-3 Bar code
LOT No. KA99B19	RANK ○-○	← Lot number * and Luminous rank , dominant wavelength rank
◁EIAJ C-3▷ MADE IN JAPAN		← Production country

<input type="checkbox"/>	<input type="checkbox"/>	<input type="checkbox"/>	<input type="checkbox"/>	<input type="checkbox"/>	<input type="checkbox"/>	<input type="checkbox"/>
①	②	③	④	⑤		

- ① Production plant code(to be indicated alphabetically)
- ② Production lot(single or double figures)
- ③ Year of production(the last two figures of the year)
- ④ Month of production
(to be indicated alphabetically with January corresponding to A)
- ⑤ Date of production(01~31)

6-3.Luminous intensity rank(Note 1) (Ta=25°C)

Rank	Luminous intensity		Unit	Condition
A	10	~ 19	mcd	I _F =20mA
B	14	~ 28		
C	21	~ 40		
D	30	~ 30		
E	43	~ 84		

(Note 1) Also I shall not ask the delivery ratio of each rank.

6-4.Dominant wavelength rank (Note 2) (Ta=25°C)

Rank	Dominant wavelength		Unit	Condition
d	562	~ 566.0	nm	I _F =20mA
e	565.0	~ 569		
f	568	~ 572.0		
g	571.0	~ 575		

(Note 2) This rank value is the setting value of when that classifies it the rank and be not a guarantee value.
Also I shall not ask the delivery ratio of each rank.

SHARP

7. Packing specification

7-1. Dampproof package

In order to avoid the absorption of humidity in transport and storage, the devices are packed in aluminum sleeve.

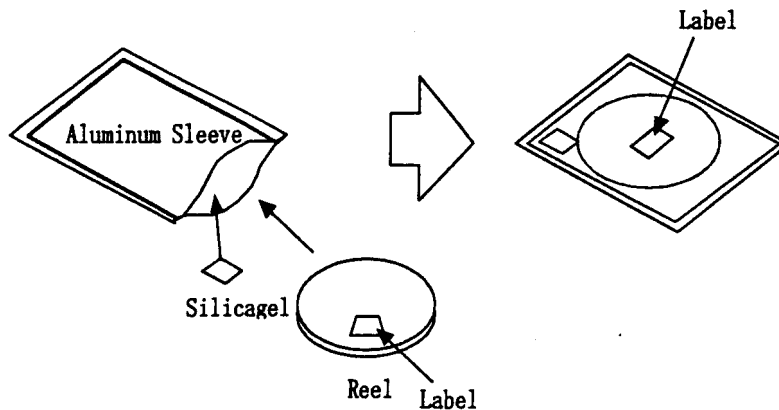

7-2. Storage conditions

Temperature : 5 to 30°C Humidity : less than 60%RH

7-3. Treatment after opening

- (1) Please make a soldering within 15 days after opening under following condition;
Temperature : 5 to 30°C Humidity : less than 60%RH
- (2) In case the devices are not used for a long time after opening, the storage in dry box is recommendable.
Or it is better to repack the devices with a desiccative by the sealer and put them in the some storage conditions as 7-2. Then they should be used within 2 weeks.
- (3) Please make a soldering after a following baking treatment if unused term should be over the conditions of (2)

*Recommendable conditions:

- ① in taping
Temperature: 60°C to 65°C, Time: 36 to 48 hours
- ② in individual (on PWB or metallic tray)
Temperature: 100°C to 120°C, Time: 2 to 3 hours

SHARP

8. Soldering

8-1. Reflow soldering

- (1) It is not recommended to exceed the soldering temperature and time shown below.
Caused by substrate bend or the other mechanical stress during reflow soldering may happen gold wire disconnection etc. Therefore please check and study your solder reflow machine's best condition.
- (2) In case of 2 times reflow process, 2nd reflow process should be done within 8 hours after 1st reflow process. (Storage condition; at 30°C, RH less than 60%RH)
- (3) Reflow soldering temperature profile to be done under the following condition.

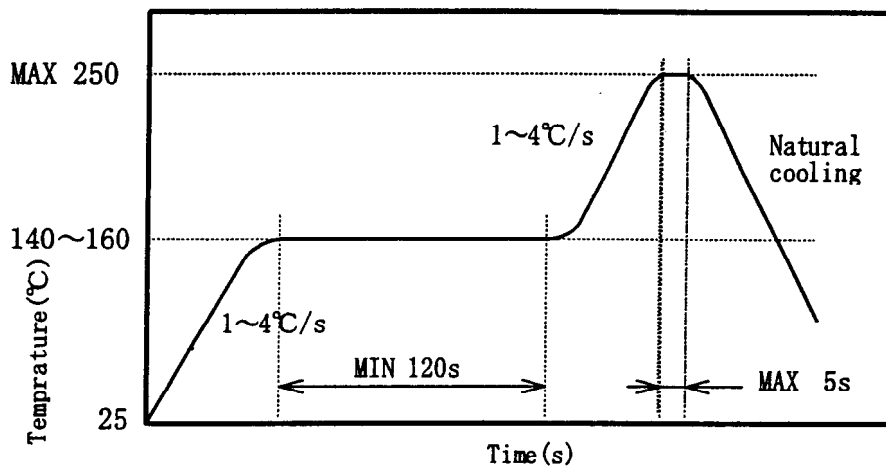

Recommendable Thermal Model

- (4) **Recommendable Metal Mask pattern for screen print**
Recommend 0.2mm to 0.3mm thickness metal mask for screen print. Caused by solder reflow condition, solder paste, substrate and the other material etc., may change solderability.
Please check and study actual solderability before usage.

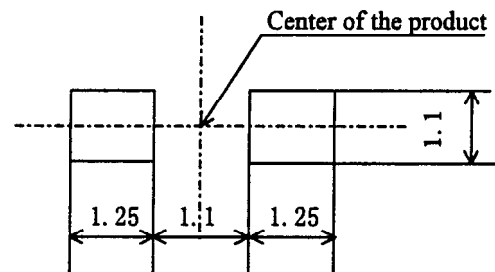

Recommended solder pattern (Unit:mm)

8-2. Manual soldering

- (1) It is recommended to keep the soldering iron temperature at 350°C (soldering iron power consumption 20W) and not to solder more than once or for over 3 seconds.
- (2) When using a soldering iron, care must be taken not to damage the package.
(Pay attention not to allow any under stress or heat on package.)

SHARP

9. Precautions for use

9-1. Precautions matters for designing circuit

This product is not designed as electromagnetic and ionized-particle radiation resistant.

9-2. Cleaning method

(1) Solvent cleaning

Recommend conditions: ① Solvent temperature is not more than 45 degree. ② Immersion up to 3 minutes.

(2) Ultrasonic cleaning

The affect on the device from ultrasonic bath, ultrasonic output, duration, board size and device mounting method.

Test the cleaning method under actual conditions and check for abnormalities before actual use.

(3) Solvents

Use only the following types of solvent.

water, methyl alcohol, ethyl alcohol, isopropyl alcohol

Recommend conditions: R.T. 40KHz, 30W/l, 3 to 5 minutes

10. Environment

10-1. Ozonosphere destructive chemicals.

(1) The device doesn't contain following substance.

(2) The device doesn't have a production line whose process requires following substance.

Restricted part: CFCs,halones,CCl₄, Trichloroethane(Methychloroform)

10-2. Bromic non-burning materials

The device doesn't contain bromic non-burning materials(PBBOs,PBBs)