

Product Specification**CONTENTS**

NO.	ITEM	PAGE
0	Record of Revisions	
1	Summary	
2	Features	
3	General Specification	
4	Interface (Input Terminal)	
5	Absolute Maximum Ratings	
6	Electrical Characteristics	
7	Electro-optical Characteristics	
8	Mechanical Characteristics	
9	Reliability Test	
10	International Standards	
11	Packing	
12	Precautions	

Product Specification

1. Summary

This module utilizes amorphous silicon thin film transistors and a 16:9 aspect ratio. A 7.0 active matrix liquid crystal display allows full color to be displayed.

The applications are Portable DVD, Multimedia applications and others AV system.

2. Features

- Utilizes a panel with a 16:9 aspect ratio, which makes the module suitable for use in wide-screen systems.
- The 7.0" screen produces a high resolution image that is composed of 112,320 pixel elements in a stripe arrangement.
- Wide viewing angle technology is employed.
[The most suitable viewing direction is in the 12 o'clock direction.]
- By adopting an active matrix drive, a picture with high contrast is realized.
- A thin, light and compact module is accomplished through the use of COG mounting technology.
- By adopting a high aperture panel, high transmittance color filter and high transmission polarizing plates, transmittance ratio is realized.

3. General Specification

CHARACTERISTIC ITEM	SPECIFICATION
Video Signal Interface	Analog Video Interface
Display Technology	a-Si TFT active matrix
Display Mode	TN Type Full Color / Transmitting Type / Normally White
Screen Size (Diagonal)	7.0"
Outline Dimension	166(W)[mm] X 100(H)[mm] X 7.0(D) [mm]
Active Area	154.08(W)[mm] X 86.58(H)[mm]
Number Of dots	480(W) X 3(RGB) X 234(H)
Dot Pitch	0.107(W)[mm] X 0.370(H)[mm]
Color Filter Array	RGB vertical stripes
Weight	162 (TYP.)
Backlight	CCFL with 3 wave-length spectrum (L Type)
Surface Treatment	Anti-Glare Treatment

Product Specification

4. Interface (Input terminal)

1> TFT-LCD Panel Driving Part

Pin No.	SYMBOL	FUNCTION	REMARK
1	VDD1	Power Line For Logic	
2	VDD1	Power Line For Logic	
3	DS	Gate Driver Double Scan Control	
4	U/D	Up/Down Scanning Change	
5	STV	Gate Scanning Start Signal (GSP)	
6	CLK	Gate Driver Scanning Clock Pulse (GSC)	
7	OE	Gate Driver Output Enable (GOE)	
8	DSOE	Gate Driver Double Scan Pulse Width Control	
9	DGND	Ground For Logic Circuit	
10	VGL	Gate Driver Negative Voltage	
11	VGH	Gate Driver Positive Voltage	
12	AGND	Ground For Analog Circuit	
13	AGND	Ground For Analog Circuit	
14	VDD2	Power Line For Source Driver IC	
15	VDD2	Power Line For Source Driver IC	
16	VB	Blue Analog Video Signal	
17	VG	Green Analog Video Signal	
18	VR	Red Analog Video Signal	
19	DGND	Ground For Logic Circuit	
20	STHL	Source Scanning Left Start Signal (SSP_L)	
21	SEQ/SIM	Sampling Mode Change	
22	L/R	Left/Right Scanning Change	
23	RESET	Source Driver Reset	
24	INH	Source Driver Output Enable (SOE)	
25	CLI1	Source Driver Clock Input 1(SSC_1)	
26	CLI2	Source Driver Clock Input 2 (SSC_2)	
27	CLI3	Source Driver Clock Input 3 (SSC_3)	
28	STHR	Source Scanning Right Start Signal (SSP_R)	
29	VEE	Gate Driver Negative Voltage For Internal Operation	
30	VCOM	Voltage Applied To Color Filter Substrate	

Product Specification

2> Backlight Fluorescent Tube Driving Part

Pin No.	SYMBOL	FUNCTION	REMARK
1	HV	Power Supply For Lamp [High Voltage Side]	[Note 4-1]
2	LV	Power Supply For Lamp [Low Voltage Side]	[Note 4-2]

The backlight interface connector is a model **BHSR-02VS-1** manufactured by JST or a model **1674817-1** manufactured by AMP. The matching connector part number is **SM02B-BHSS-1-TB** or equivalent.

[Note 4-1] The wire color of high voltage side is pink.

[Note 4-2] The wire color of low voltage side is white. Connect the low voltage side of the DC/AC inverter used to drive the fluorescent tube to GND of the inverter circuit.

PRELIMINARY SPECIFICATION

Product Specification

5. Absolute Maximum Ratings

PARAMETER	SYMBOL	CONDITION	MIN.	MAX.	UNIT	REMARK
Logic Voltage	VDD1	T _a =25°C	-0.5	6.0	V	
Source Driver Voltage	VDD2	T _a =25°C	-0.5	6.0	V	
Digital Input Signals	V _{DI}	T _a =25°C	-0.5	VDD1+0.5	V	[Note 5-1]
Analog Input Signals	V _{AI}	T _a =25°C	-0.5	VDD2+0.5	V	[Note 5-2]
Gate Driver High Supply Voltage	VGH	T _a =25°C	-0.5	28	V	
Gate Driver Internal Negative Supply Voltage	VEE	T _a =25°C	-16	0.5	V	
Gate Driver Low Supply Voltage	VGL	T _a =25°C	VEE-0.3	VEE+7.0	V	
Storage Temperature	T _{st}	-	TBD	TBD	°C	[Note 5-3,4]
Operating Temperature (Panel Surface)	T _p	-	TBD	TBD	°C	[Note 5-3,4,5]
Operating Temperature (Ambient Temperature)	T _a	-	TBD	TBD	°C	[Note 5-6]

[Note 5-1] DS, U/D, STV, CLK, OE, DSOE, STHL, SEQ/SIM, RL, RESET, INH, CLI1, CLI2, CLI3, STHR

[Note 5-2] VR, VG, VB

[Note 5-3] This rating applies to all parts of the module and should not be exceeded.

[Note 5-4] Maximum wet-bulb temperature is 60°C. Condensation of dew must be avoided as electrical current leaks will occur, causing a degradation of performance specifications.

[Note 5-5] The operating temperature only guarantees operation of the circuit and doesn't guarantee all the contents of Electro-optical specification.

[Note 5-6] Ambient temperature when the backlight is lit (reference value).

Product Specification

6. Electrical Characteristics

1> Recommended Operating Conditions

◆ TFT-LCD Panel Driving Section

T_a=25℃

PARAMETER		SYMBOL	MIN.	TYP.	MAX.	UNIT	REMARK
Logic Supply Voltage		VDD1	3.0	3.3	3.6	V	
Digital Input Signal	High Level	V _{IH}	0.8VDD1	-	VDD1	V	
	Low Level	V _{IL}	0	-	0.2VDD1	V	
Source Driver Supply Voltage		VDD2	4.5	5.0	5.5	V	
Gate Driver	High Supply Voltage		VGH	TBD	TBD	TBD	V
	Low Supply Voltage	AC	VGL _{AC}	TBD	TBD	TBD	V _{P-P}
		DC	VGL _{DC}	TBD	TBD	TBD	V
	Internal Negative Supply Voltage		VEE	TBD	TBD	TBD	V
Analog Video Signal Input Voltage		V _{VI}	VSS+0.2	-	VDD2-0.2	V	
Color Filter Substrate Voltage	AC Component	VCOM _{AC}	TBD	TBD	TBD	V _{P-P}	
	DC Component	VCOM _{DC}	TBD	TBD	TBD	V	

***** Cautionary Matter : When applying or disconnecting power, please be sure that such action is simultaneously carried out for all power supplies. In addition, apply input signals only after power has been turned on.

-Source Driver :

Turn on power to VDD1, logic input, VDD2, and video signal input in this order.
Turn off power in the reverse order.

-Gate Driver :

Turn on power to VDD1, VEE, VGL, VGH, and logic input in this order.
Turn off power in the reverse order.

Product Specification

PARAMETER	SYMBOL	MIN.	TYP.	MAX.	UNIT	REMARK
Logic Supply Current	I_{DD1}	-	3.0	5.0	mA	VDD1 = 3.3V
Source Driver Supply Current	I_{DD2}	-	30	50	mA	VDD2 = 5.0V
Gate Driver Internal Negative Supply Current	I_{EE}	-	TBD	TBD	mA	
Gate Driver High Supply Current	I_{GH}	-	TBD	TBD	mA	
Gate Driver Low Supply Current	I_{GL}	-	TBD	TBD	mArms	

◆ Backlight Driving Section

PARAMETER	SYMBOL	MIN.	TYP.	MAX.	UNIT	REMARK
Lamp Current	I_{BL}	3.0	6.0	7.0	mArms	
Lamp Voltage	V_{BL}	530	555	670	Vrms	±10[%]
Lamp Power Consumption	P_{BL}	2.01	3.33	3.71	Wrms	
Lamp Frequency	f_{BL}	45	-	60	kHz	*1
		45	-	80		*2
Kick-Off Voltage (*3)	V_S	-	-	1080	Vrms	$T_a=25^\circ\text{C}$
		-	-	1350	Vrms	$T_a=0^\circ\text{C}$
Discharge Stabilization Time	T_S	-	-	3	Minutes	*4
Lift Time	-	20,000	-	-	Hour	*5

Product Specification

- * 1 : The frequency range can be kept within $\pm 10\%$ range of electrical and optical characteristics.
- * 2 : The frequency range will not affect to lamp life and reliability characteristics.
(The lamp frequency should be selected as different as possible from display horizontal synchronous signal (Including harmonic frequency of this scanning frequency) to avoid "Beat" interference which may be observed on the screen as horizontal stripes like moving wave. This phenomenon is caused by interference between lamp (CCFL) lighting frequency and LCD horizontal synchronous signal.)
- * 3 : The "MAX" of "Kick-Off Voltage" means the minimum voltage for inverter to turn on the CCFL normally in the LCD module. However this isn't the values that we can assure stability of starting lamp on condition that the module is installed in your set.
It is careful that "Kick-Off Voltage" is changed by an increase of stray capacitance in your set, inverter method, value of ballast capacitor in your inverter and so on.
Especially, the value of "Kick-Off Voltage" is higher in low temperature condition than in normal temperature condition, because impedance of CCFL is increased.
- * 4 : The time needed to achieve not less than 95% brightness of the center part of lamp.
The brightness of the lamp after lighted for 5 minutes is defined as 100%.
- * 5 : "Life time" is defined as the lamp brightness decrease to 50% original brightness at $I_{BL} = TYP$; continuous lighting, $T_a = 25^\circ C$.

Inverter should be designed to be subject to the conditions below;

- A. Both the area and the peak under the positive and negative cycles of the waveform of the lamp current and lamp voltage should be symmetric. (The symmetric ratio should be larger than 90%)
- B. There should not be any spikes in the waveform.
- C. The waveform should be close to a sine wave whenever possible.
- D. Lamp current should not exceed the "MAX" value under the "Operating Temperature" (it is prohibited to exceed the "MAX" value even if it is operated in the non-guaranteed temperature).
When lamp current exceed the maximum value for a long time, it may cause a smoking and ignition. Therefore, it is recommended that the inverter have the current limited circuit that is used as a protection circuit and/or the lamp current-controlled inverter.

Product Specification

2> Timing Characteristics of input signals

	PARAMETER	SYMBOL	MIN.	TYP.	MAX.	UNIT	REMARK
S O U R C E	Clock Pulse Width	PW _{CLI}	33	-	-	ns	
	Start Pulse Setup Time	t _{SETUP}	8	-	-	ns	
	Start Pulse Hold Time	t _{HOLD}	8	-	-	ns	
	Reset Pulse Width	PW _{RES}	66	-	-	ns	
	INH Setup Time	t _{ISETUP}	33	-	-	ns	
	INH Hold Time	t _{IHOLD}	33	-	-	ns	
	Reset-INH Time	t _{R-I}	81	-	-	ns	
	INH Pulse Width	PW _{INH}	5	-	-	CLK	
***** Keep the rise and fall times of the logic input signals to within tr=tf=5ns (10 to 90%).							
G A T E	Clock Pulse High Width	PW _{CLK(H)}	(500)	-	-	ns	
	Clock Pulse Low Width	PW _{CLK(L)}	(500)	-	-	ns	
	Enable Pulse Width	PW _{OE}	(1000)	-	-	ns	
	Start Pulse Setup Time	t _{SETUP1}	(200)	-	-	ns	
	Start Pulse Hold Time	t _{HOLD1}	(200)	-	-	ns	
	Double Scan Setup Time	t _{SETUP2}	(200)	-	-	ns	
	Double Scan Hold Time	t _{HOLD2}	(200)	-	-	ns	
***** The value enclosed in parentheses is a reference value.							

3> Signal For Reverse Scanning

MODE	L/R	U/D	STHL	STHR	STV	REMARK
Normal Mode	L	L	Signal Input	Signal Output	Input	
Right/Left Reverse Mode	H	L	Signal Output	Signal Input	Input	
Up/Down Reverse Mode	L	H	Signal Input	Signal Output	Input	
Left/Right & Up/Down Reverse Mode	H	H	Signal Output	Signal Input	Input	

***** H(High Level) =VDD1 / L(Low Level)=DGND

Product Specification

Start Pulse Input Timing

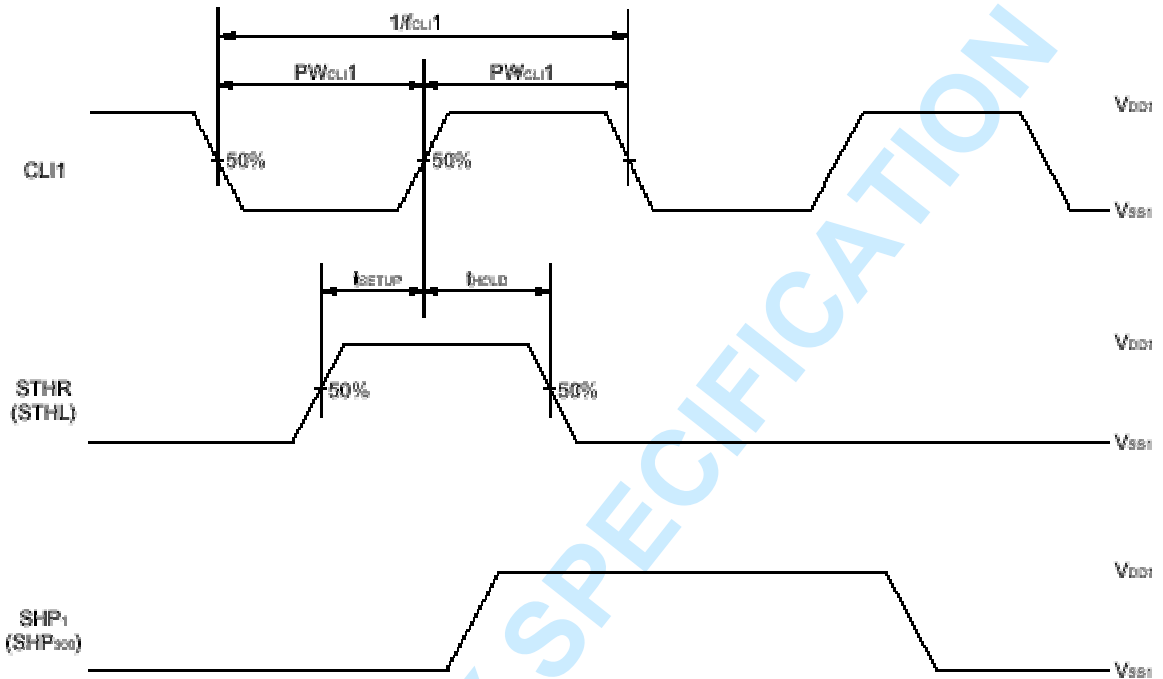

Start Pulse Output Timing

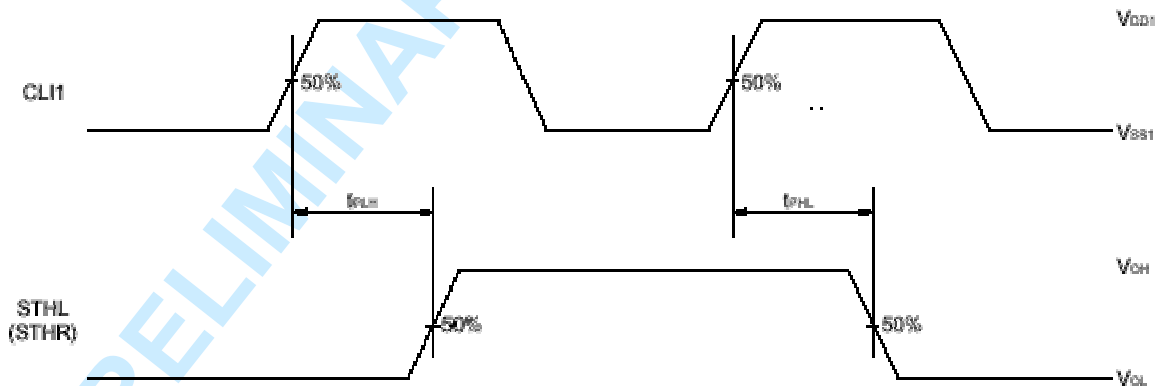

Remark The input/output timing of the start pulse is the same for simultaneous/successive sampling.

Product Specification

Reset INH Pulse Timing

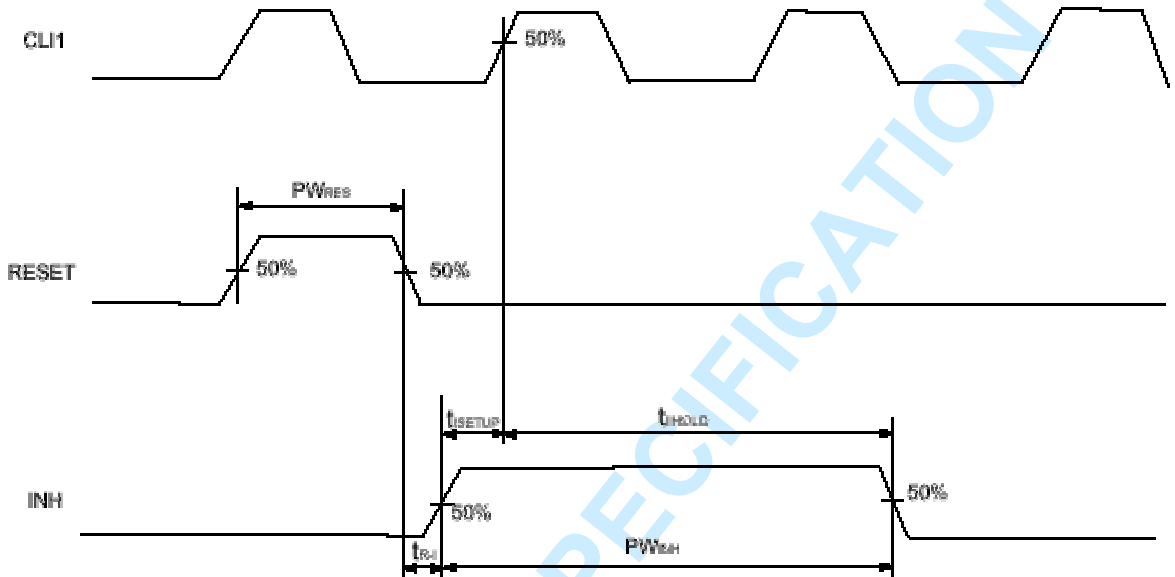

PRELIMINARY SPECIFICATION

Product Specification

Switching Characteristics Waveform (L/R =H)

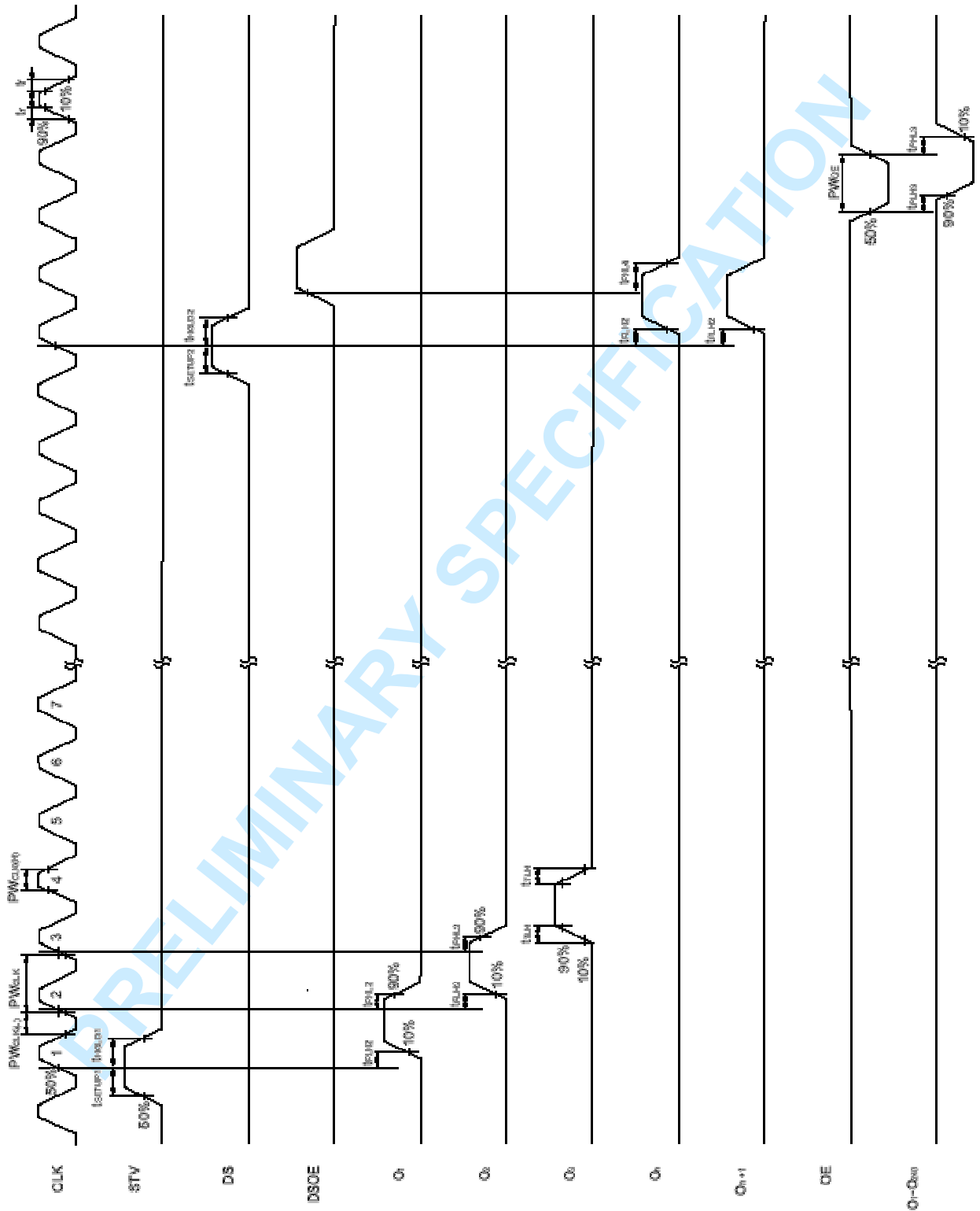

Product Specification

7. Electro-optical Characteristics

$T_a=25^{\circ}\text{C}$

PARAMETER	SYMBOL	CONDITION	MIN.	TYP.	MAX.	UNIT	REMARK
Luminance	Y	$I_{BL}=6\text{mA rms}$	TBD	(350)	-	cd/m^2	[Note 7-1]
Contrast Ratio	CR	Optimal	TBD	400	-	-	[Note 7-2]
White Color Chromaticity	W_x	$I_{BL}=6\text{mA rms}$	0.298	0.313	0.328	-	[Note 7-1]
	W_y		0.314	0.329	0.344	-	
Viewing Angle	$\phi=180^{\circ}$	Θ_l	CR \geq 10	60	-	-	[Note 7-2] [Note 7-3]
	$\phi=0^{\circ}$	Θ_r		60	-	-	
	$\phi=90^{\circ}$	Θ_u		50	-	-	
	$\phi=270^{\circ}$	Θ_d		40	-	-	
Response Time	Rise	τ_r	$\Theta=0^{\circ}$	-	5	-	[Note 7-4]
	Fall	τ_d		-	20	-	

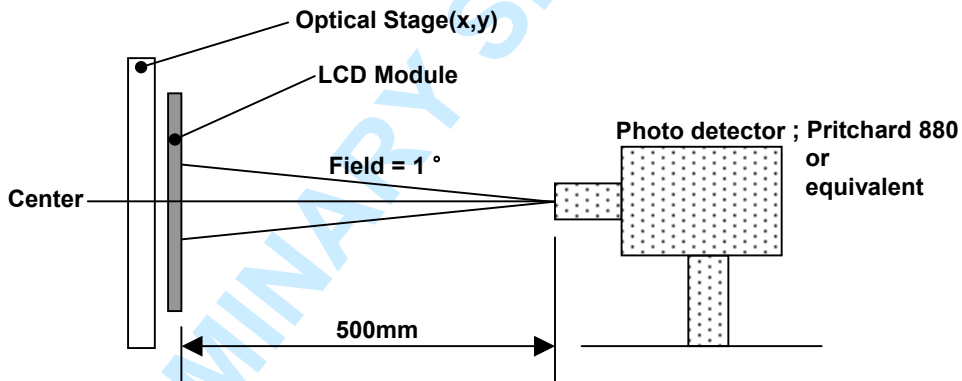

Measuring Condition ;

-Measuring surroundings : Dark Room

-Measuring temperature : $T_a=25^{\circ}\text{C}$

-Adjust operating voltage to get optimum contrast at the center of the display.

-Measured value at the center point of LCD panel after more than 30 minutes while backlight turning on.

Product Specification

[Note 7-1]

Measured on the center area of the panel by PHOTO RESEARCH photometer PR-880.

[Note 7-2]

Contrast ratio is defined as follows ;

$$\text{Contrast Ratio(CR)} = \frac{\text{Photo detector output with LCD being "white"}}{\text{Photo detector output with LCD being "black"}}$$

[Note 7-3]

Viewing angle range is defined as follows;

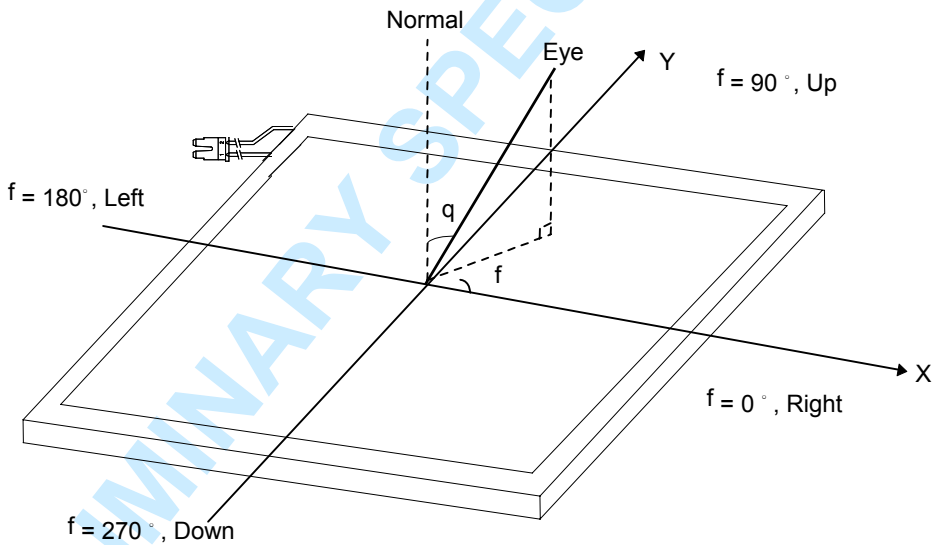

PRELIMINARY SPECIFICATION

Product Specification

[Note 7-4]

Response time is obtained by measuring the transition time of photo detector output, when input signals are applied so as to make the area “black” to and from “white”.

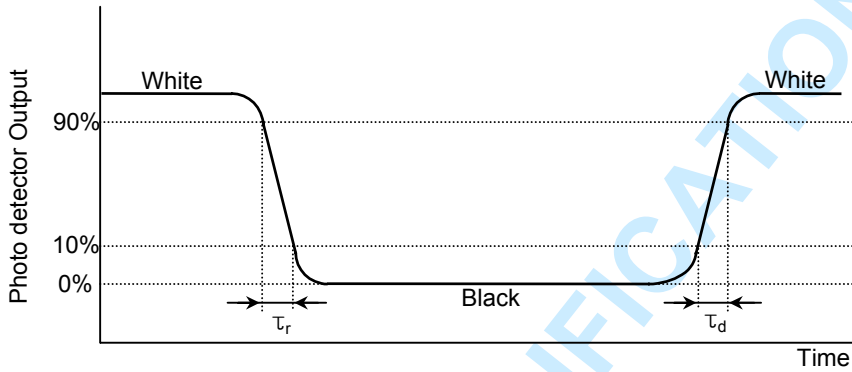

PRELIMINARY SPECIFICATION

Product Specification

8. Mechanical Characteristics

PARAMETER	SPECIFICATION		UNIT	REMARK
Outline Dimension	Wide	166	mm	
	Height	100	mm	
	Depth	7.0 (TYP.)	mm	
Bezel Area	Wide	157.2	mm	
	Height	89.6	mm	
Active Display Area	Wide	154.08	mm	
	Height	86.58	mm	
Weight	162 (TYP.)		g	
Surface Treatment	Anti-Glare Treatment		-	

PRELIMINARY SPECIFICATION

Product Specification

[Outline Dimension]

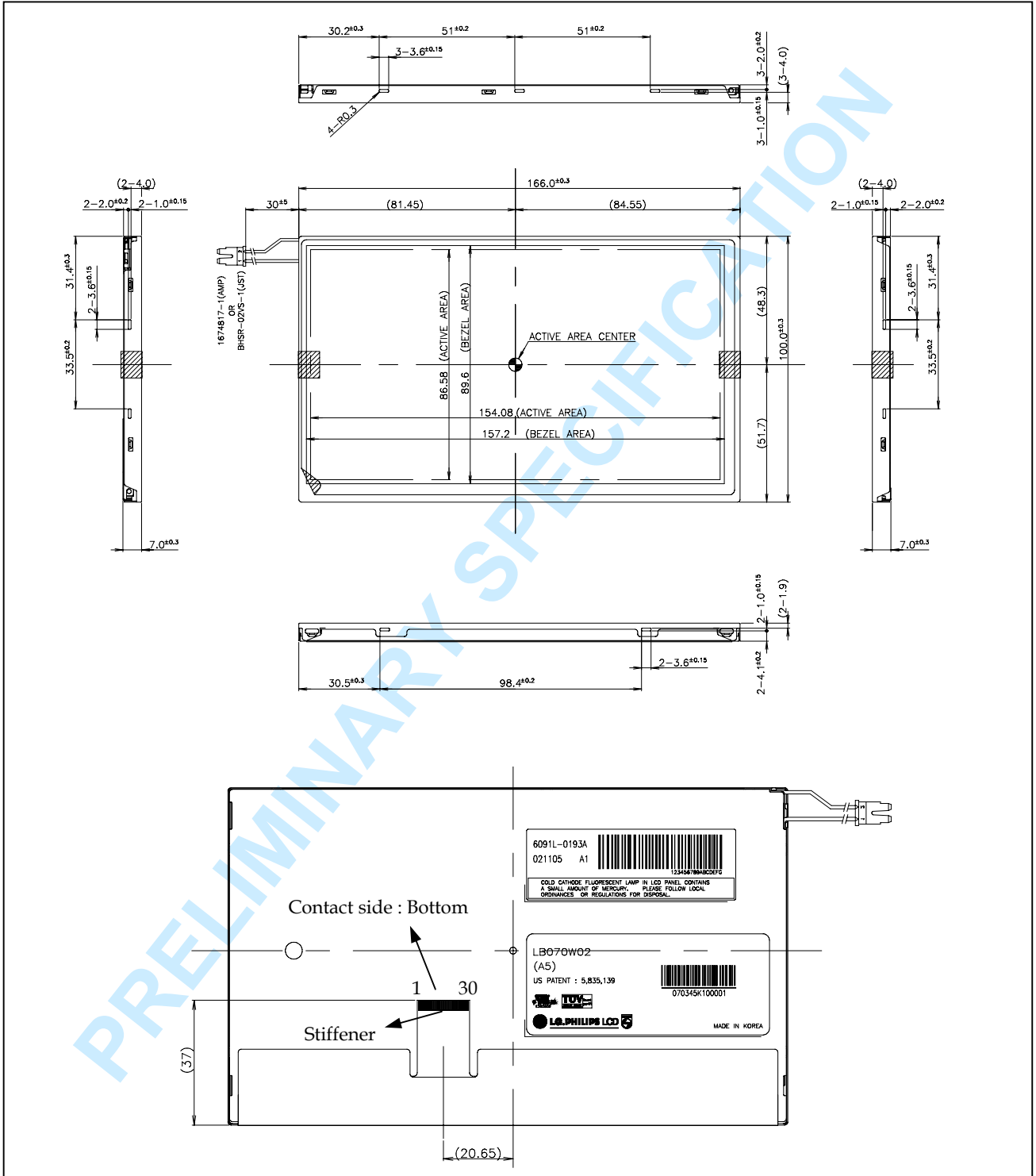

Product Specification

9. Reliability Test

No.	Test Items	Test Condition	REMARK
1	High Temperature Storage Test	TBD	
2	Low Temperature Storage Test	TBD	
3	High Temperature Operation Test	TBD	
4	Low Temperature Operation Test	TBD	
5	High Temperature and High Humidity Operation Test	TBD	
6	Electro Static Discharge Test	TBD	
7	Shock Test	TBD	
8	Vibration Test	TBD	
9	Thermal Shock Test	TBD	

***** T_a = Ambient Temperature, T_p = Panel Temperature

PRELIMINARY SPECIFICATION

Product Specification

10. International Standards

10-1. Safety

- a) UL 1950 Third Edition, Underwriters Laboratories, Inc. Jan. 28, 1995.
Standard for Safety of Information Technology Equipment Including Electrical Business Equipment.
- b) CAN/CSA C22.2 No. 950-95 Third Edition, Canadian Standards Association, Jan. 28, 1995.
Standard for Safety of Information Technology Equipment Including Electrical Business Equipment.
- c) EN 60950 : 1992+A1: 1993+A2: 1993+A3: 1995+A4: 1997+A11: 1997
IEC 950 : 1991+A1: 1992+A2: 1993+A3: 1995+A4: 1996
European Committee for Electrotechnical Standardization(CENELEC)
EUROPEAN STANDARD for Safety of Information Technology Equipment Including Electrical
Business Equipment.

10-2. EMC

- a) ANSI C63.4 "Methods of Measurement of Radio-Noise Emissions from Low-Voltage Electrical and Electrical Equipment in the Range of 9kHz to 40GHz." American National Standards Institute(ANSI), 1992
- b) C.I.S.P.R "Limits and Methods of Measurement of Radio Interface Characteristics of Information Technology Equipment." International Special Committee on Radio Interference
- c) EN 55022 "Limits and Methods of Measurement of Radio Interface Characteristics of Information Technology Equipment." European Committee for Electrotechnical Standardization (CENELEC), 1998

Product Specification

11. Packing

11-1. Designation of Lot Mark

a) Lot Mark

A	B	C	D	E	F	G	H	I	J	K	L	M
---	---	---	---	---	---	---	---	---	---	---	---	---

A,B,C : SIZE(INCH)

D : YEAR

F : PANEL CODE

H : ASSEMBLY CODE

E : MONTH

G : FACTORY CODE

I,J,K,L,M : SERIAL NO.

Note

1. YEAR

Year	97	98	99	2000	2001	2002	2003	2004	2005	2006	2007
Mark	7	8	9	0	1	2	3	4	5	6	7

2. MONTH

Month	Jan	Feb	Mar	Apr	May	Jun	Jul	Aug	Sep	Oct	Nov	Dec
Mark	1	2	4	4	5	6	7	8	9	A	B	C

3. PANEL CODE

Panel Code	P1 Factory	P2 Factory	P3 Factory	P4 Factory	P5 Factory	Hydis Panel
Mark	1	2	3	4	5	H

4. FACTORY CODE

Factory Code	LPL Gumi	LPL Nanjing
Mark	K	C

5. SERIAL NO.

Year	1 ~ 99999	100000 ~
Mark	00001 ~ 99999	A0001 ~ A9999, , Z9999

b) Location of Lot Mark

Serial NO. is printed on the label. The label is attached to the backside of the LCD module.
This is subject to change without prior notice.

11-2. Packing Form

a) Package quantity in one box : 20 pcs

b) Box Size : 335×384×282 (mm)

Product Specification

12. PRECAUTIONS

Please pay attention to the following when you use this TFT LCD module.

12-1. MOUNTING PRECAUTIONS

- (1) You must mount a module using holes arranged in four corners or four sides.
- (2) You should consider the mounting structure so that uneven force(ex. Twisted stress) is not applied to the module.
And the case on which a module is mounted should have sufficient strength so that external force is not transmitted directly to the module.
- (3) Please attach a transparent protective plate to the surface in order to protect the polarizer.
Transparent protective plate should have sufficient strength in order to resist external force.
- (4) You should adopt radiation structure to satisfy the temperature specification.
- (5) Acetic acid type and chlorine type materials for the cover case are not described because the former generates corrosive gas of attacking the polarizer at high temperature and the latter causes circuit break by electro-chemical reaction.
- (6) Do not touch, push or rub the exposed polarizers with glass, tweezers or anything harder than HB pencil lead. And please do not rub with dust clothes with chemical treatment.
Do not touch the surface of polarizer for bare hand or greasy cloth.(Some cosmetics are determined to the polarizer.)
- (7) When the surface becomes dusty, please wipe gently with absorbent cotton or other soft materials like chamois soaks with petroleum benzene. Normal-hexane is recommended for cleaning the adhesives used to attach front / rear polarizers. Do not use acetone, toluene and alcohol because they cause chemical damage to the polarizer.
- (8) Wipe off saliva or water drops as soon as possible. Their long time contact with polarizer causes deformations and color fading.
- (9) Do not open the case because inside circuits do not have sufficient strength.

12-2. OPERATING PRECAUTIONS

- (1) The spike noise causes the mis-operation of circuits. It should be lower than following voltage :
 $V = \pm 200\text{mV}$ (Over and under shoot voltage)
- (2) Response time depends on the temperature.(In lower temperature, it becomes longer.)
- (3) Brightness depends on the temperature. (In lower temperature, it becomes lower.)
And in lower temperature, response time(required time that brightness is stable after turned on) becomes longer.
- (4) Be careful for condensation at sudden temperature change. Condensation makes damage to polarizer or electrical contacted parts. And after fading condensation, smear or spot will occur.
- (5) When fixed patterns are displayed for a long time, remnant image is likely to occur.
- (6) Module has high frequency circuits. Sufficient suppression to the electromagnetic interference shall be done by system manufacturers. Grounding and shielding methods may be important to minimize the interference.

Product Specification

12-3. ELECTROSTATIC DISCHARGE CONTROL

Since a module is composed of electronic circuits, it is not strong to electrostatic discharge. Make certain that treatment persons are connected to ground through wrist band etc. And don't touch interface pin directly.

12-4. PRECAUTIONS FOR STRONG LIGHT EXPOSURE

Strong light exposure causes degradation of polarizer and color filter.

12-5. STORAGE

When storing modules as spares for a long time, the following precautions are necessary.

- (1) Store them in a dark place. Do not expose the module to sunlight or fluorescent light. Keep the temperature between 5°C and 35°C at normal humidity.
- (2) The polarizer surface should not come in contact with any other object.
It is recommended that they be stored in the container in which they were shipped.

12-6. HANDLING PRECAUTIONS FOR PROTECTION FILM

- (1) When the protection film is peeled off, static electricity is generated between the film and polarizer. This should be peeled off slowly and carefully by people who are electrically grounded and with well ion-blown equipment or in such a condition, etc.
- (2) The protection film is attached to the polarizer with a small amount of glue. If some stress is applied to rub the protection film against the polarizer during the time you peel off the film, the glue is apt to remain on the polarizer.
Please carefully peel off the protection film without rubbing it against the polarizer.
- (3) When the module with protection film attached is stored for a long time, sometimes there remains a very small amount of glue still on the polarizer after the protection film is peeled off.
- (4) You can remove the glue easily. When the glue remains on the polarizer surface or its vestige is recognized, please wipe them off with absorbent cotton waste or other soft material like chamois soaked with normal-hexane.