

FEATURES

- Integrated Downconverter
- Integrated Dual Synthesizer
- 256 QAM Compatibility
- Single +5 V Power Supply Operation
- Low Power Consumption: <0.6 W
- Low Noise Figure: 8 dB
- High Conversion Gain: 10 dB
- Low Distortion: -53 dBc
- Two-Wire Interface
- Small Size
- -40 °C to +85 °C

APPLICATIONS

- Set Top Boxes
- CATV Video Tuners
- Digital TV Tuners
- CATV Data Tuners
- Cable Modems

PRODUCT DESCRIPTION

The ACD2203 uses both GaAs and Si technology to provide the downconverter and dual synthesizer functions in a double conversion tuner gain block, local oscillator, balanced mixer and dual synthesizer. The specifications meet the requirements of CATV/TV/Video and Cable Modem Data applications. The ACD2203 is supplied in a 28 lead SSOP package and requires a single +5 V supply voltage.

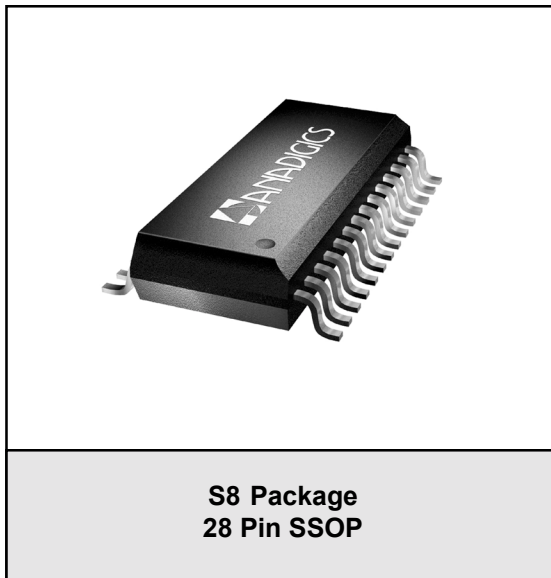

The IC is well suited for applications where small size, low cost, low auxiliary parts count and a no-compromise performance is important. It provides for cost reduction by lowering the component and packaged IC count and decreasing the amount of labor-intensive production alignment steps, while significantly improving performance and reliability.

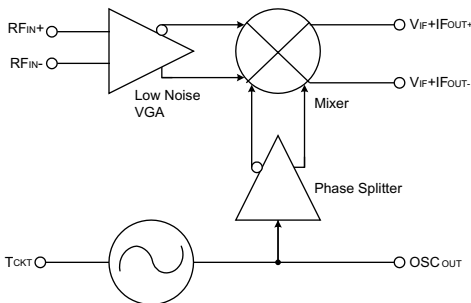

Figure 1: Downconverter Block Diagram

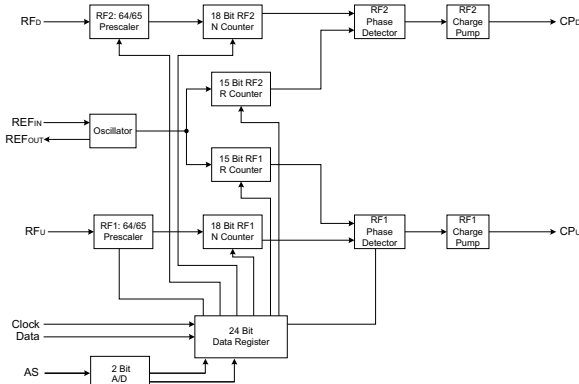

Figure 2: Dual Synthesizer Block Diagram

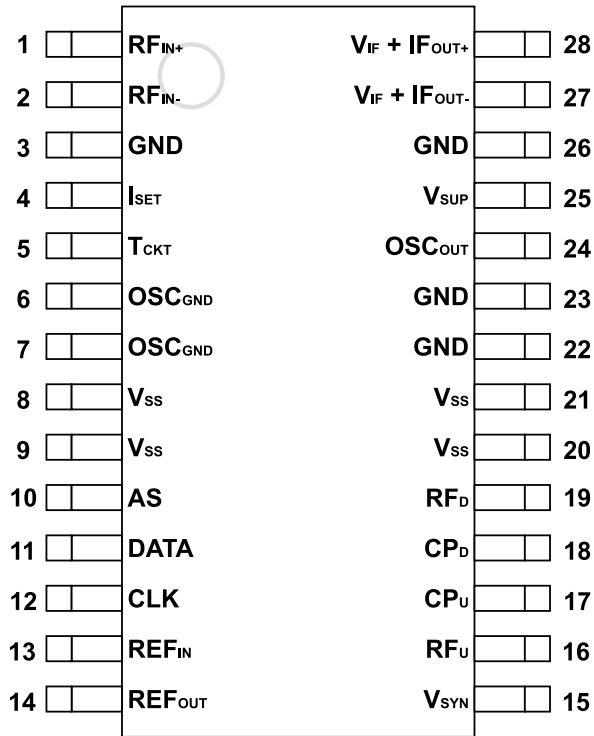

Figure 3: Pinout

Table 1: Pin Description

PIN	NAME	DESCRIPTION	PIN	NAME	DESCRIPTION
1	RF _{IN+}	Downconverter Differential RF Input	28	V _{IF+IFOUT+}	Downconverter Differential IF Output Inductively coupled to +V _{DD}
2	RF _{IN-}	Downconverter Differential RF Input	27	V _{IF+IFOUT-}	Downconverter Differential IF Output Inductively coupled to +V _{DD}
3	GND	Downconverter Ground (Must be connected)	26	GND	Downconverter Ground (Must be connected)
4	I _{SET}	Downconverter Gilbert Cell Current Source Resistor	25	V _{SUP}	Oscillator and Phase Splitter Supply (+V _{DD})
5	T _{CKT}	Oscillator Input Port (Tank circuit connection)	24	OSC _{OUT}	Oscillator Output (Connected to Synthesizer RF Input)
6	OSC _{GND}	Oscillator Tank Circuit Ground (Not to be connected to any other circuit ground)	23	GND	Downconverter Ground (Must be connected)
7	OSC _{GND}	Same as Pin 6	22	GND	Downconverter Ground (Must be connected)
8	V _{SS}	Synthesizer Ground (Required)	21	V _{SS}	Synthesizer Ground (Required)
9	V _{SS}	Synthesizer Ground (Required)	20	V _{SS}	Synthesizer Ground (Required)
10	AS	Address Select	19	RF _D	Synthesizer Downconverter RF Input
11	DATA	2-Wire Interface Data	18	CP _D	Synthesizer Downconverter Charge Pump Output
12	CLK	2-Wire Interface Clock	17	CP _U	Synthesizer Upconverter Charge Pump Output
13	REF _{IN}	Crystal Reference Input	16	RF _U	Synthesizer Upconverter RF Input
14	REF _{OUT}	Crystal Reference Output	15	V _{SYN}	Synthesizer Supply (+V _{DD})

ELECTRICAL CHARACTERISTICS

Table 2: Absolute Minimum and Maximum Ratings

PARAMETER	MIN	MAX	UNIT
Supply Voltage (pins 25, 27 & 28) (pin 15)	- -	+9 +6.5	VDC
Voltage on pins 10 through 14, 16 through 19 with $V_{SS} = 0$ V	-0.3	$V_{SYN} + 0.3$	VDC
Input Voltages (pins 1, 2 & 5)	-	0	VDC
Input Power (pins 1 & 2) (pin 5) (pins 13, 16 & 19)	- - -	+10 +17 +20	dBm
Storage Temperature	-55	+150	°C
Soldering Temperature	-	260	°C
Soldering Time	-	4	Sec
Thermal Impedance, θ_{JC}	-	40	°C/W

Stresses in excess of the absolute ratings may cause permanent damage. Functional operation is not implied under these conditions. Exposure to absolute ratings for extended periods of time may adversely affect reliability.

Table 3: Operating Ranges

PARAMETER	MIN	TYP	MAX	UNIT
Downconverter Frequencies ⁽¹⁾ RF Input (RF) IF Output (IF) Local Oscillator (LO)	900 35 865	- - -	1200 150 1350	MHz
Synthesizer Frequencies Upconverter Synthesizer (RF_U) Downconverter Synthesizer (RF_D) Reference Oscillator (REF_N) Phase Detector	400 400 2 -	- - 4 -	2100 1400 20 10	MHz
Supply Voltage: V_{DD} (pins 15, 25, 27, 28)	+4.70	+5	+5.25	VDC
Ambient Operating Temperature: T_A ⁽²⁾	-40	-	+85	°C

The device may be operated safely over these conditions; however, parametric performance is guaranteed only over the conditions defined in the electrical specifications.

Notes:

- (1) Mixer operation is possible beyond these frequencies with slightly reduced performance.
- (2) Case Temperature is 15 °C higher than Ambient Temperature, when Ambient Temperature is +25 °C, using the PC Board Layout shown in Figures 24-26.

Table 4: Electrical Specifications - Downconverter Section
 ($T_A = +25\text{ }^\circ\text{C}$ ⁽⁷⁾, $V_{DD} = +5\text{ VDC}$, $R_{F_{IN}} = 1087\text{ MHz}$, $I_{F_{OUT}} = 45\text{ MHz}$)

PARAMETER	MIN	TYP	MAX	UNIT
Conversion Gain ⁽¹⁾	8	10	14	dB
Conversion Gain ⁽²⁾	11	13	17	
SSB Noise Figure ^{(2), (3)}	-	4	7	dB
Cross Modulation ^{(2), (4), (6)}	-	-56	-53	dBc
3 rd Order Intermodulation Distortion (IMD3) ^{(2), (5), (6)}	-	-	-53	dBc
2-Tone 3 rd Order Input Intercept Point (IIP3) ^{(2), (5), (6)}	+12	-	-	dBm
LO Phase Noise (@ 10 KHz Offset) ^{(1), (2)}	-	-90	-85.5	dBc/Hz
LO Output Power (pin 24) ^{(1), (2)}	-10	-5	-	dBm
Spurious @ IF Output				
LO Signals and Harmonics	-	-10	-	dBm
Beats Within Output Channel	-	-48	-	dBc
Other Beats from 2 to 200 MHz	-	-50	-	dBm
Other Spurious	-	-10	-	dBm
IF Supply Current (pin 27 & 28) ^{(1), (2), (6)}	-	50	65	mA
Osc/Phase Splitter Supply Current (pin 25)	-	30	45	mA
Power Consumption	-	400	550	mW

Notes:

- (1) As measured in ANADIGICS test fixture with single-ended RF input.
 (2) As measured in ANADIGICS test fixture with differential RF inputs.
 (3) SSB noise figure will be approximately 3 dB higher with single-ended RF input.
 (4) Two tones: 1085 and 1091 MHz, -20 dBm each, 1091 MHz tone AM-modulated 99% at 15 kHz.
 (5) Two tones: 1085 and 1091 MHz, -15 dBm each.
 (6) $R_1 = 10\text{ Ohms}$.
 (7) Case Temperature is 15 °C higher than Ambient Temperature, when Ambient Temperature is +25 °C, using the PC Board Layout shown in Figures 24-26.

Table 5: Electrical Specifications - Synthesizer Section
($T_A = +25\text{ }^\circ\text{C}$ ⁽⁴⁾, $V_{DD} = +5\text{ VDC}$)

PARAMETER	MIN	TYP	MAX	UNIT	COMMENTS
Prescaler Input Sensitivity					(over operating frequency)
Upconverter: RF _U (pin 16) ⁽¹⁾	-7	-	+20	dBm	$T_A = +85\text{ }^\circ\text{C}$, $V_{DD} = +4.7\text{ V}$ $T_A = +85\text{ }^\circ\text{C}$, $V_{DD} = +4.7\text{ V}$
Downconverter: RF _D (pin 19) ⁽²⁾	-13	-	+20		
Upconverter: RF _U (pin 16) ⁽¹⁾	-6	-	-		
Downconverter: RF _D (pin 19) ⁽²⁾	-11	-	-		
Reference Oscillator Sensitivity (pin 13)	-	0.5	-	V _{p-p}	
Charge Pump Output Current ⁽³⁾					
SINK	-	1.25	-	mA	
SOURCE	-	-1.25	-		
Supply Current	-	35	50	mA	
Power Consumption	-	165	250	mW	

Notes:

(1) Measured at 250 kHz comparison frequency.

(2) Measured at 62.5 kHz comparison frequency.

(3) CP_U and $CP_D = V_{CC}/2$.

(4) Case Temperature is 15 °C higher than Ambient Temperature, when Ambient Temperature is +25 °C, using the PC Board Layout shown in Figures 24-26.

Table 6: Digital 2-Wire Interface Specifications
($T_A = +25\text{ }^\circ\text{C}$, $V_{DD} = +5\text{ VDC}$, ref. Figure 4)

PARAMETER	SYMBOL	MIN	MAX	UNIT
CLK Frequency	f_{CLK}	1	400	kHz
Logic High Input (pins 11, 12)	V_H	2.0	-	V
Logic Low Input (pins 11, 12)	V_L	-	0.8	V
Logic Input Current Consumption (pins 11, 12)	I_{LOG}	-	10	μA
Address Select Input Current Consumption (pin 10)	I_{AS}	-	10	μA
Data Sink Current ⁽²⁾	I_{AK}	-	4.0	mA
Bus Free Time between a STOP and START Condition	t_{BUF}	1.3	-	μs
Hold Time (repeated) START Condition. After this period, the first clock pulse is generated.	$t_{HD,STA}$	0.6	-	μs
LOW period of CLK	t_{LOW}	1.3	-	μs
HIGH period of CLK	t_{HIGH}	0.6	-	μs
Set-up Time for a Repeated START Condition	$t_{SU,STA}$	0.6	-	μs
Data Hold Time (for 2-wire bus devices)	$t_{HD,DAT}$	0.0	0.9	μs
Data Set-up Time	$t_{SU,DAT}$	100	-	ns
Rise Time of DATA and CLK Signals	t_R	$20 + 0.1C_b^{(1)}$	300	ns
Fall Time of Data and CLK Signals	t_F	$20 + 0.1C_b^{(1)}$	300	ns
Set-up Time for STOP Condition	$t_{SU,STO}$	0.6	-	μs
Capacitive Load for Each Bus Line	C_b	-	400	pF

Notes:

(1) C_b is the total capacitance of one bus line in pF.

(2) For maximum 0.8 V level during Acknowledge Pulse.

3. All timing values are referred to minimum V_H and maximum V_L levels.

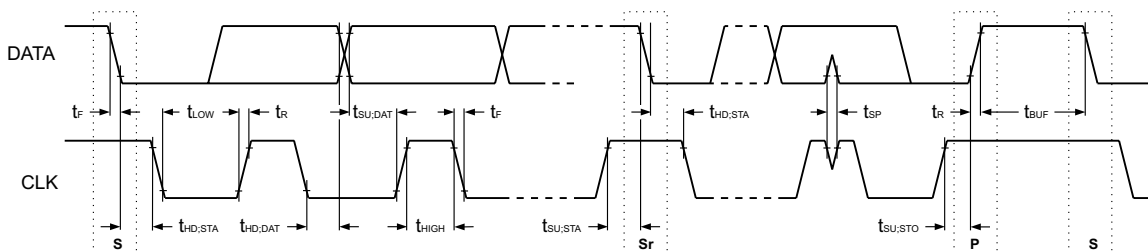

Figure 4: Serial 2-Wire Data Input Timing

PERFORMANCE DATA

Figure 5: Typical Conversion Gain and Noise Figure vs. Supply Voltage
 (T_A = +25 °C, f_{LO2} = 1042 MHz)

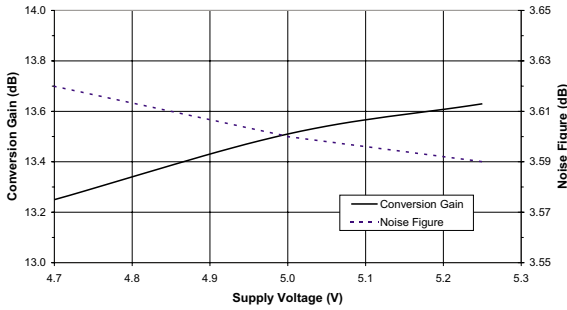

Figure 6: Typical Conversion Gain and Noise Figure vs. Ambient Temperature
 (V_{DD} = +5 V, f_{LO2} = 1042 MHz)

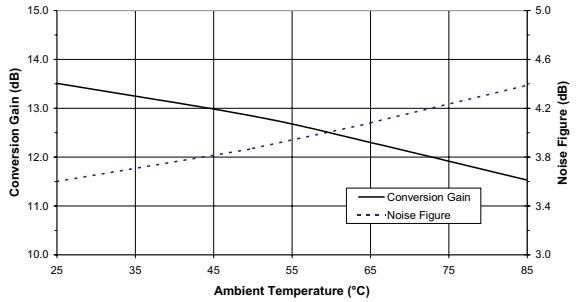

Figure 7: Typical Phase Noise at 10 kHz Offset vs. Supply Voltage
 (T_A = +25 °C, f_{LO2} = 1042 MHz)

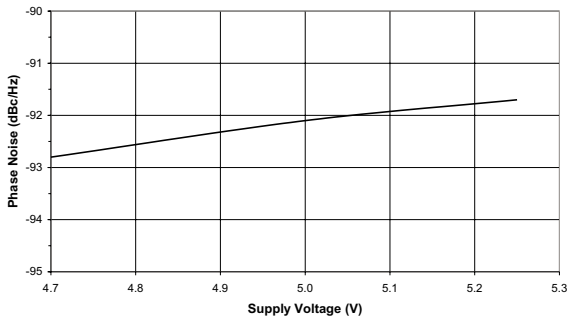

Figure 8: Typical Phase Noise at 10 kHz Offset vs. Ambient Temperature
 (V_{DD} = +5 V, f_{LO2} = 1042 MHz)

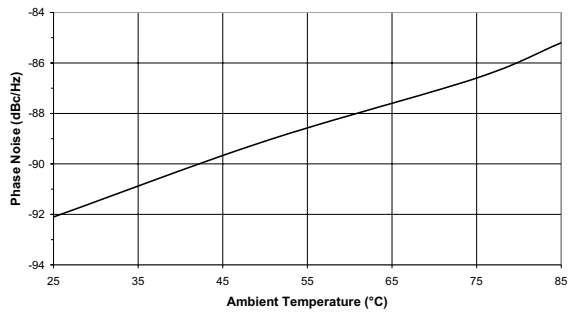

Figure 9: Typical Local Oscillator Output Power vs. Supply Voltage
 (T_A = +25 °C, f_{LO2} = 1042 MHz)

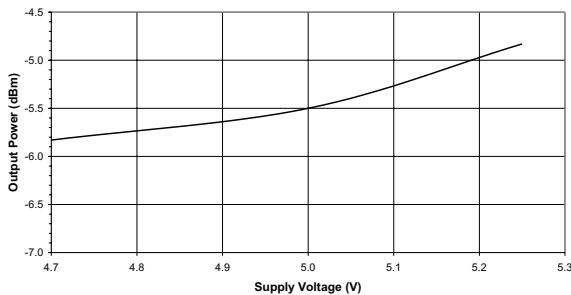

Figure 10: Typical Local Oscillator Output Power vs. Ambient Temperature
 (V_{DD} = +5 V, f_{LO2} = 1042 MHz)

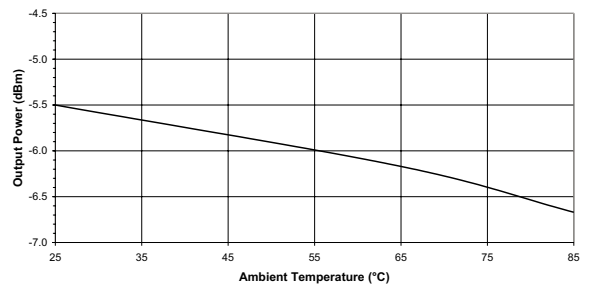

Figure 11: Typical Upconverter Prescaler Sensitivity vs. Local Oscillator Frequency
 ($T_A = +25\text{ }^\circ\text{C}$, $V_{DD} = +5\text{ V}$)

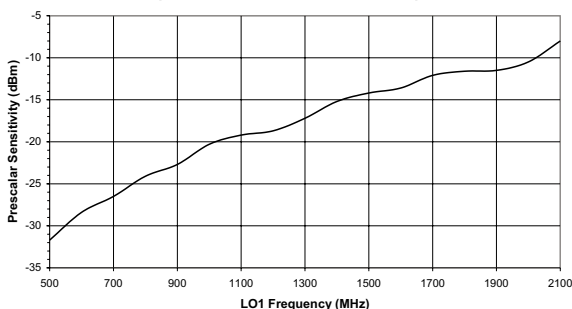

Figure 12: Typical Downconverter Prescaler Sensitivity vs. Local Oscillator Frequency
 ($T_A = +25\text{ }^\circ\text{C}$, $V_{DD} = +5\text{ V}$)

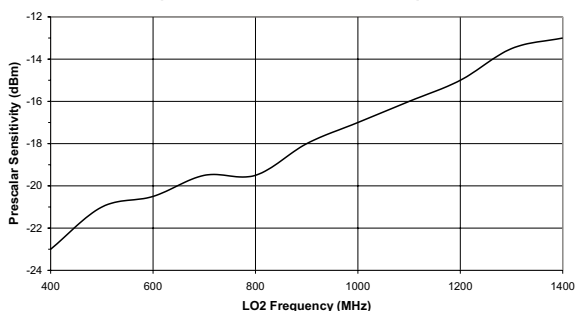

Figure 13: Typical Upconverter Prescaler Sensitivity vs. Supply Voltage
 ($T_A = +25\text{ }^\circ\text{C}$, $f_{LO1} = 2100\text{ MHz}$)

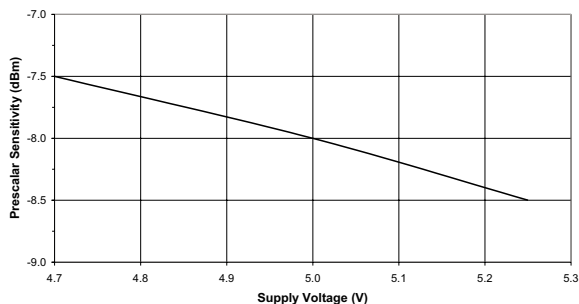

Figure 14: Typical Downconverter Prescaler Sensitivity vs. Supply Voltage
 ($T_A = +25\text{ }^\circ\text{C}$, $f_{LO2} = 1000\text{ MHz}$)

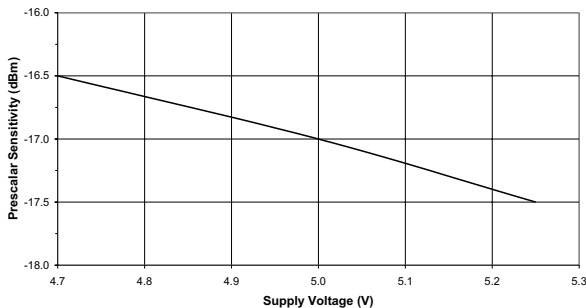

Figure 15: Typical Upconverter Prescaler Sensitivity vs. Ambient Temperature
 ($V_{DD} = +5\text{ V}$, $f_{LO1} = 2100\text{ MHz}$)

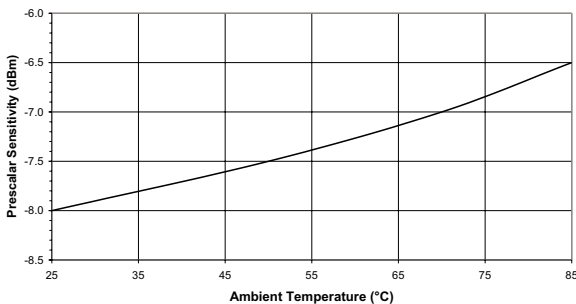

Figure 16: Typical Downconverter Prescaler Sensitivity vs. Ambient Temperature
 ($V_{DD} = +5\text{ V}$, $f_{LO2} = 1000\text{ MHz}$)

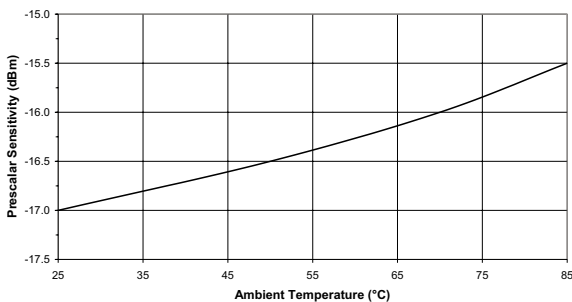

Figure 17: Typical Conversion Gain and Noise Figure vs. LNA/Mixer Current Control Resistor R1
 (T_A = +25 °C, V_{DD} = +5 V, f_{L02} = 1042 MHz)

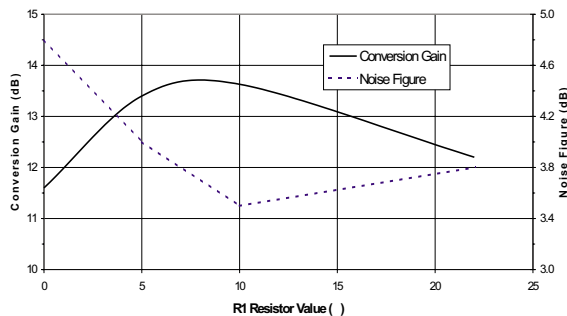

Figure 18: Typical Total Current Consumption vs. LNA/Mixer Current Control Resistor R1
 (T_A = +25 °C, V_{DD} = +5 V)

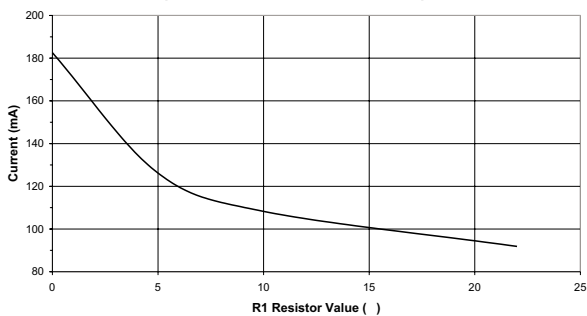

Figure 19: Typical Input IP3 vs. LNA/Mixer Current Control Resistor R1
 (T_A = +25 °C, V_{DD} = +5 V)

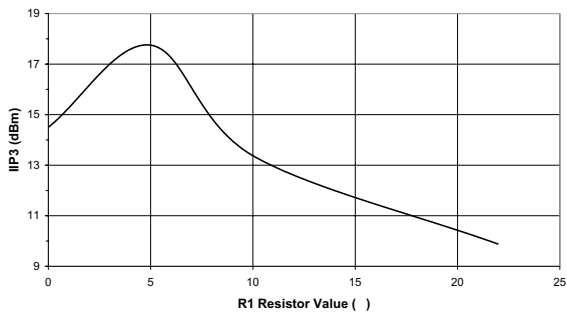
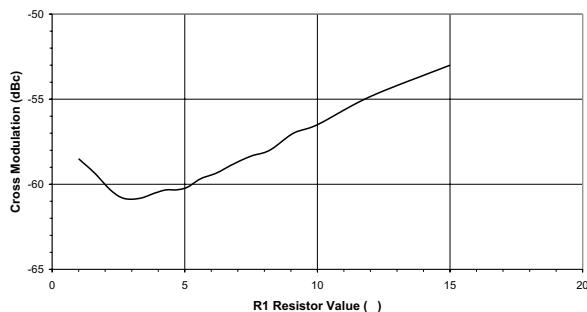

Figure 20: Typical Cross Modulation vs. LNA/Mixer Current Control Resistor R1
 (T_A = +25 °C, V_{DD} = +5 V)



LOGIC PROGRAMMING

The ACD2203 includes an interface for a two-wire serial data control bus that ANADIGICS has developed for use with its dual PLL synthesizers. This interface saves one connection between the host and the dual synthesizer, compared to a standard CLOCK-DATA-ENABLE three-wire interface. The interface is optimized for applications in which the dual synthesizer is a slave receiver device. Hosts that conform to the I²C-Bus Specification standard can be used to program a dual PLL that uses this interface.

Physical Interface

The two-wire interface consists of two digital signal lines, CLOCK and DATA. The speed of the interface is nominally 400 kbits/sec. For data transmission, the signal on the DATA line must be stable when the CLOCK signal is high, and the state of the data must change only while the CLOCK signal is low. A logic level transition on the DATA line during a high CLOCK signal indicates the beginning or end of a data transmission, as specified in the following sections and shown in Figure 21.

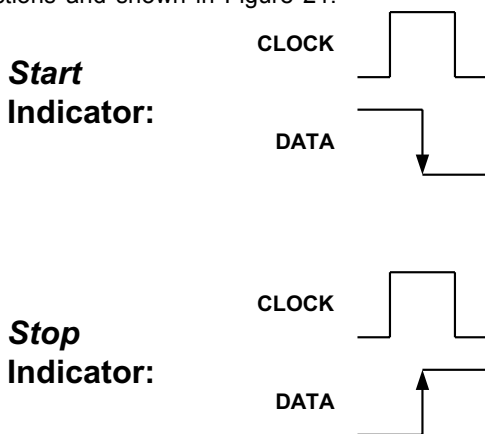

Figure 21: Transmission Indicators

Addressing The Dual PLL

The dual PLL monitors the CLOCK and DATA signals for a *Start* indication from the host. A *Start* is indicated by a high-to-low transition of the DATA signal while the CLOCK signal is high. Immediately following the *Start* indicator, the host sends an 8-bit address word to the dual PLL. The 8-bit word required to address the dual PLL is programmable via a DC voltage level applied to the address select pin. For example, a voltage of $4V < AS < 5V$ corresponds to a value of C6h, or 1100110b. (The MSB is sent first, LSB last.) The Address Select pin

(10) decodes an analog voltage input into two digital logic output bits AS1 and AS2. The level of a DC voltage applied to this pin determines the two-bit logic state, AS2 and AS1 to address the synthesizer. The software must be programmed with the corresponding decimal equivalent of the 8b word selected, as shown in Table 7. Once the dual PLL has recognized the *Start* indicator and the correct address word, it sends an address acknowledgement to the host by pulling the DATA line low for one clock pulse. The host can then begin to send data to program the dual PLL.

Sending Data

After receiving the address byte acknowledgement from the dual PLL, the host begins sending programming data in 8-bit words. The MSB is sent first, and the LSB last. Following the receipt of each 8-bit data word, the dual PLL acknowledges receipt by pulling the DATA line low for one clock pulse. The data acknowledgement tells the host it may send the next data word. For the dual PLL, each group of three data words (24 bits total) is a significant block of information used to program one of four registers, as described in "Programming the Dual PLL."

Completing Data Transmissions

After sending the final data word, the host sends a *Stop* indicator to mark the end of data transmission. A *Stop* is indicated by a low-to-high transition of the DATA signal while the CLOCK signal is held high. After receiving the *Stop* indicator, the dual PLL ceases to send further acknowledgements and begins to monitor the CLOCK and DATA signals for the next *Start* indicator.

Note: The Stop indicator does not directly control when the programming data is latched or takes effect; the data takes effect immediately following the receipt of each three-word block of data, which represents a complete 24-bit divider register.

Resending Data

If, for some reason, the data transmission fails or is interrupted, and the dual PLL fails to send an address word or data word acknowledgement to the host, the host can resend the data. To resend data, a new *Start* indicator and address word must be sent prior to any data words.

Programming The Dual PLL

Each synthesizer in the dual PLL contains programmable Reference and Main dividers, which

Table 7: Address Select Decoding
(T_A = +25 °C ⁽¹⁾, V_{DD} = +5 VDC)

VOLTAGE ON PIN 10, AS	C (BINARY 12)				AS2 AS1				HEX	DECIMAL
	B7	B6	B5	B4	B3	B2	B1	B0		
V _{SS} < AS < 0.8V	1	1	0	0	0	0	1	0	C2	194
1.1V < AS < 1.7V	1	1	0	0	0	0	0	0	C0	192
2.1V < AS < 2.7V	1	1	0	0	0	1	0	0	C4	196
3.15V < AS < 3.65V	1	1	0	0	0	0	0	0	C0	192
4.2V < AS < V _{DD}	1	1	0	0	0	1	1	0	C6	198

Notes:

(1) Case Temperature is 15 °C higher than Ambient Temperature, when Ambient Temperature is +25 °C, using the PC Board Layout shown in Figures 24-26.

allow a wide range of output frequencies. The 24-bit registers that control the dividers and other functions are each segmented into three 8-bit data words, and are programmed via the two-wire interface.

Register Select Bits

The two least significant bits of each register are register select bits that determine which register is programmed during a particular data entry cycle. Table 8 indicates the register select bit settings used to program each of the available registers.

Table 8: Register Select Bits

SELECT BITS		DESTINATION REGISTER FOR SERIAL DATA
S 2	S 1	
0	0	Reference Divider Register for PLL2
0	1	Main Divider Register for PLL2
1	0	Reference Divider Register for PLL1
1	1	Main Divider Register for PLL1

Reference Divider Programming

The reference divider register for each synthesizer consists of fifteen divider bits, five program mode bits and the two register select bits, as shown in Table 9. The fifteen divider bits allow a divide ratio from 3 to 32767, inclusive, as shown in Table 10.

Main Divider Programming

The main divider register for each synthesizer consists of seven A counter bits, eleven B counter bits, two program mode bits and the two register select bits, as shown in Table 11. The main divider divide ratio, N, is determined by the values in the A and B counters. The eleven B Counter bits and allowed values are shown in Table 12, and the seven A Counter bits and allowed values are shown in Table 13. Note that there are some limitations on the ranges of the values for each counter.

Pulse Swallow Function

The VCO output frequency for the local oscillator is computed using the following equation; the variables are defined in Table 14:

$$f_{VCO} = N \times f_{osc}/R, \text{ where } N = [(P \times B) + A]$$

where:

$$N = [(P \times B) + A]$$

f_{VCO} is the desired output frequency

B is the divide ratio of the B counter (3 to 2047)

A is the divide ratio of the A counter (0 < A < P, A < B)

f_{osc} is the frequency of the reference oscillator

R is the divide ratio of the R counter (3 to 32767)

P is the preset modulus of the prescaler (P=64).

Table 9: Reference Divider Registers

		MSB																LSB							
Data Word	FIRST DATA WORD							SECOND DATA WORD							THIRD DATA WORD										
Register Bit	24	23	22	21	20	19	18	17	16	15	14	13	12	11	10	9	8	7	6	5	4	3	2	1	
Function	Dummy/Spacer		Program Mode					Reference Divider Divide Ratio, R																Select	
Data	X	X	D	D	D	D	D	R	R	R	R	R	R	R	R	R	R	R	R	R	R	R	R	S	S
	2	1	5	4	3	2	1	15	14	13	12	11	10	9	8	7	6	5	4	3	2	1	2	1	

Table 10: Reference Divider R Counter Bits

DIVIDE RATIO R	R 15	R 14	R 13	R 12	R 11	R 10	R 9	R 8	R 7	R 6	R 5	R 4	R 3	R 2	R 1
3	0	0	0	0	0	0	0	0	0	0	0	0	0	1	1
4	0	0	0	0	0	0	0	0	0	0	0	0	1	0	0
-	-	-	-	-	-	-	-	-	-	-	-	-	-	-	-
32767	1	1	1	1	1	1	1	1	1	1	1	1	1	1	1

Notes:

Divide ratios less than 3 are prohibited.

Table 11: Main Divider Registers

		MSB																LSB						
Data Word	FIRST DATA WORD							SECOND DATA WORD							THIRD DATA WORD									
Register Bit	24	23	22	21	20	19	18	17	16	15	14	13	12	11	10	9	8	7	6	5	4	3	2	1
Function	Dummy/Spacer		Program Mode		B Counter											A Counter					Select			
Data	X	X	C	C	B	B	B	B	B	B	B	B	B	B	B	A	A	A	A	A	A	A	S	S
	2	1	2	1	11	10	9	8	7	6	5	4	3	2	1	7	6	5	4	3	2	1	2	1

Table 12: Main Divider B Counter Bits

VALUE OF B COUNTER	B 11	B 10	B 9	B 8	B 7	B 6	B 5	B 4	B 3	B 2	B 1
3	0	0	0	0	0	0	0	0	0	1	1
4	0	0	0	0	0	0	0	0	1	0	0
-	-	-	-	-	-	-	-	-	-	-	-
2047	1	1	1	1	1	1	1	1	1	1	1

Notes:

B > A, Divide ratios less than 3 are prohibited.

Table 13: Main Divider A Counter Bits

VALUE OF A COUNTER	A 7	A 6	A 5	A 4	A 3	A 2	A 1
0	0	0	0	0	0	0	0
1	0	0	0	0	0	0	1
-	-	-	-	-	-	-	-
127	1	1	1	1	1	1	1

Notes:

 $B > A, A < P$ **Table 14: Phase Detector Polarity Bit**

S 2	S 1	D 1
0	0	PLL2 Phase Detector Polarity
1	0	PLL1 Phase Detector Polarity

Programmable Modes

Each register contains bits set aside for programming different modes of operation in the synthesizers. Bit D1 in each reference divider register controls the phase detector polarity. Table 14 shows how this bit controls the polarity, and the correct setting is determined by using Table 15 and Figure 22.

Table 15: Phase Detector Polarity Selection

D 1	POLARITY	VCO CHARACTERISTICS
0	Negative	curve (2)
1	Positive	curve (1)

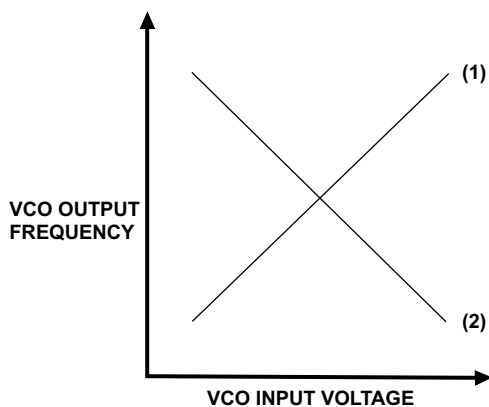
**Figure 22: VCO Characteristics**

Bit C1 in each main divider register sets the prescaler mode. Table 16 indicates the appropriate settings. (Currently, there is only one prescaler mode available for use.)

Table 16: Prescaler Mode

C 1	PRESCALAR MODE
0	64/65
1	(reserved for future use)

Bit C2 in the main divider registers, bits D2 through D5 in the reference divider registers, and bits X1 and X2 in all registers are reserved for future use, and have no current function. They can be set either high or low without affecting synthesizer performance.

Synthesizer Programming Example

The following example for programming the two synthesizers in the dual PLL details the calculations used to determine the required value of each bit in all four registers:

Requirements

Desired CATV input channel: "HHH" - 499.25 MHz picture carrier (501 MHz digital channel center frequency)

(Second) IF picture carrier output frequency: 45.75 MHz (44 MHz digital channel center frequency)

First IF frequency: 1087.75 MHz (recommended)

Phase detector comparison frequency for down converter (also tuning increment): 62.5 KHz

Phase detector comparison frequency for up converter: 250 KHz

Crystal reference oscillator frequency: 4 MHz

Calculation of Reference Divider Values

The value for each reference divider is calculated by dividing the reference oscillator frequency by the desired phase detector comparison frequency:

$$R = f_{OSC} / f_{PD}$$

For the down converter, the 4 MHz crystal oscillator frequency and the 62.5 KHz phase detector comparison frequency are used to yield $R_{PLL2} = 4 \text{ MHz} / 62.5 \text{ KHz} = 64$, and so the bit values for the down converter R counter are $R_{PLL2} = 000000001000000$.

For the up converter, the 4 MHz crystal oscillator frequency and the 250 KHz phase detector comparison frequency are used to yield $R_{PLL1} = 4 \text{ MHz} / 250 \text{ KHz} = 16$, and so the bit values for the up converter R counter are $R_{PLL1} = 00000000010000$.

Calculation of Main Divider Values

The values for the A and B counters are determined by the desired VCO output frequency for the local oscillator and the phase detector comparison frequency:

$$N = f_{VCO} / f_{PD}$$

$$B = \text{trunc}(N / P)$$

$$A = N - (B \times P)$$

The down converter local oscillator frequency will be $1087.75 \text{ MHz} - 45.75 \text{ MHz} = 1042 \text{ MHz}$ in this example. The main divider ratio for the down converter, then, is $N_{PLL2} = 1042 \text{ MHz} / 62.5 \text{ KHz} = 16672$. Since $P = 64$ in the ACD2203, $B_{PLL2} = \text{trunc}(16672 / 64) = 260$, and $A_{PLL2} = 16672 - (260 \times 64) = 32$. These results give bit values of $B_{PLL2} = 00100000100$ and $A_{PLL2} = 0100000$ for the B and A counters.

The up converter local oscillator frequency will be $499.25 \text{ MHz} + 1087.75 \text{ MHz} = 1587 \text{ MHz}$ in this example. Therefore, $N_{PLL1} = 1587 \text{ MHz} / 250 \text{ KHz} = 6348$, $B_{PLL1} = \text{trunc}(6348 / 64) = 99$, and $A_{PLL1} = 6348 - (99 \times 64) = 12$. These results give bit values of $B_{PLL1} = 00001100011$ and $A_{PLL1} = 0001100$ for the B and A counters.

Phase Detector Polarity

If the VCO for the up converter has a negative slope, the phase detector polarity for PLL1 should be negative, and $D1_{PLL1} = 1$. If the VCO for the down converter has a positive slope, the phase detector polarity for PLL2 should be positive, and $D1_{PLL2} = 0$.

In summary, for this example, the four register programming words are shown in Tables 17 and 18 on the following page.

**Table 17: PLL1 and PLL2 Reference Divider Register Bits
for Synthesizer Programming Example**

		MSB																LSB							
Data Word	FIRST DATA WORD							SECOND DATA WORD							THIRD DATA WORD										
Register Bit	24	23	22	21	20	19	18	17	16	15	14	13	12	11	10	9	8	7	6	5	4	3	2	1	
Function	Dummy/ Spacer	Program Mode					Reference Divider Divide Ratio, R															Select			
Data	X	X	D	D	D	D	D	R	R	R	R	R	R	R	R	R	R	R	R	R	R	R	R	S	S
PLL2	0	0	0	0	0	0	1	0	0	0	0	0	0	0	0	0	1	0	0	0	0	0	0	0	0
PLL1	0	0	0	0	0	0	0	0	0	0	0	0	0	0	0	0	0	1	0	0	0	0	0	1	0

**Table 18: PLL1 and PLL2 Main Divider Register Bits
for Synthesizer Programming Example**

		MSB																LSB						
Data Word	FIRST DATA WORD							SECOND DATA WORD							THIRD DATA WORD									
Register Bit	24	23	22	21	20	19	18	17	16	15	14	13	12	11	10	9	8	7	6	5	4	3	2	1
Function	Dummy/ Spacer	Program Mode	B Counter											A Counter					Select					
Data	X	X	C	C	B	B	B	B	B	B	B	B	B	B	B	A	A	A	A	A	A	A	S	S
PLL2	0	0	0	0	0	0	1	0	0	0	0	0	1	0	0	0	1	0	0	0	0	0	0	1
PLL1	0	0	0	0	0	0	0	0	1	1	0	0	0	1	1	0	0	0	1	1	0	0	1	1

APPLICATION INFORMATION

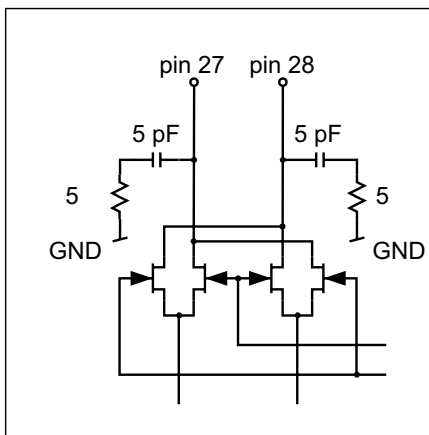
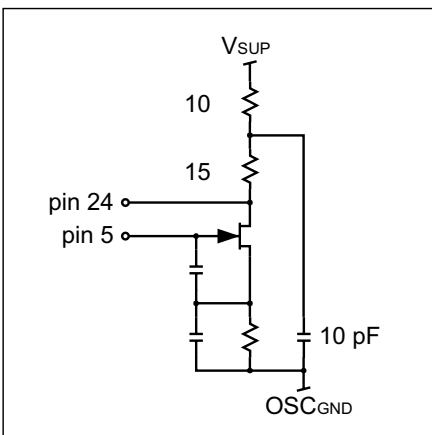
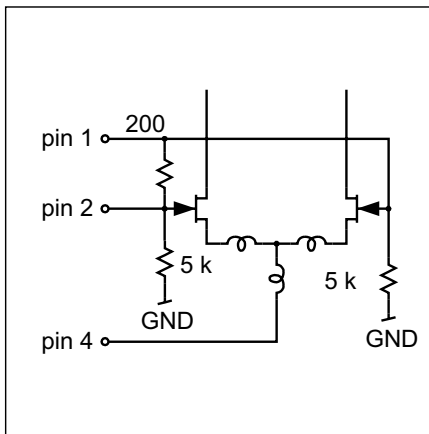
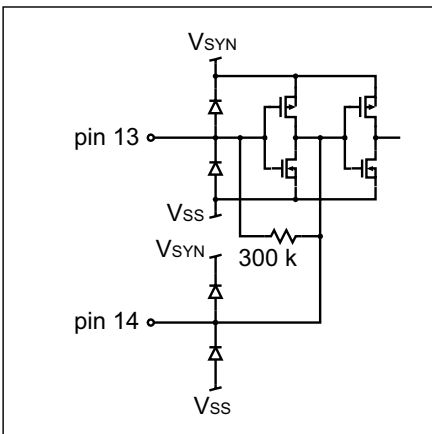
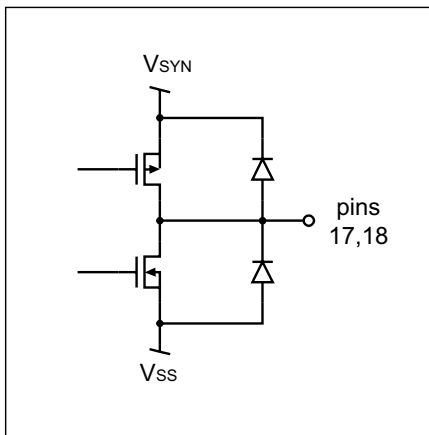
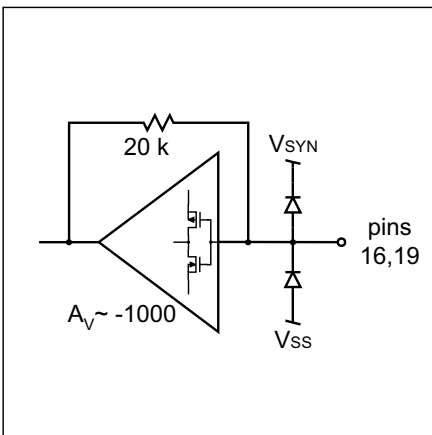

Figure 23: Equivalent Circuits

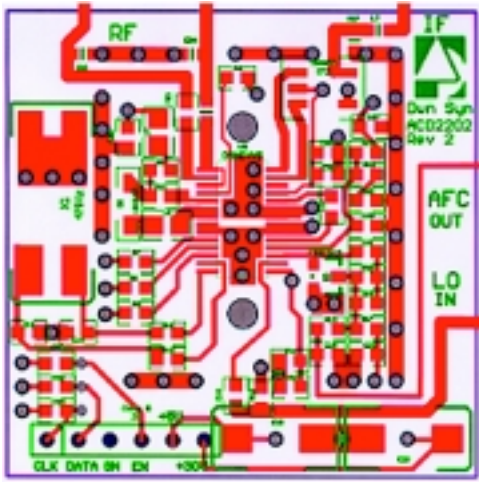

Figure 24: PC Board Layout Top View

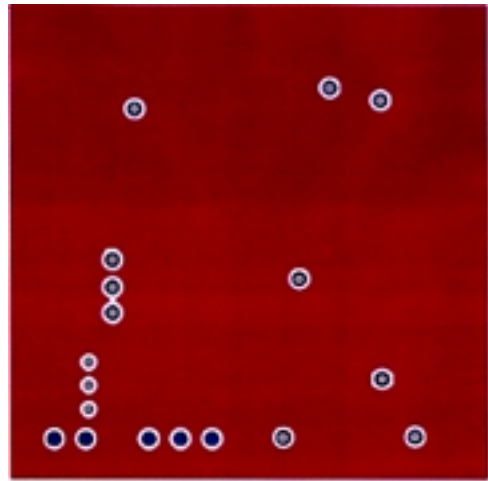

Figure 25: PC Board Layout Mid View

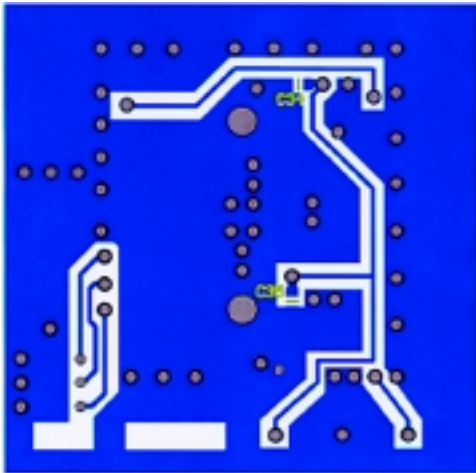

Figure 26: PC Board Layout Bottom View

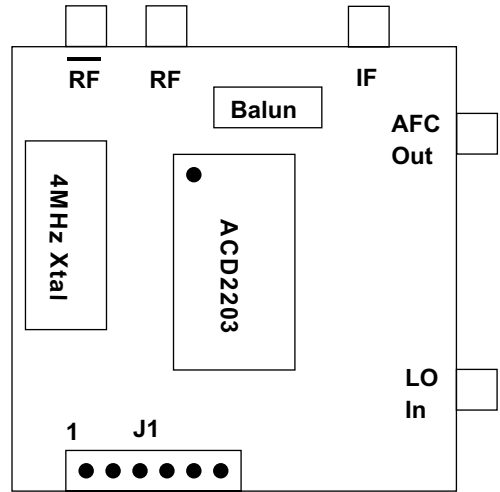

Figure 27: Evaluation Fixture

Table 19: J1 Header Pinout

PIN	FUNCTION
1	Clock
2	Data
3	Ground
4	AS
5	+5 VDC
6	+30 VDC

Table 20: Fixture Pinout

PIN	FUNCTION
RF	Downconverter RF Input
RF	Downconverter RF Input
IF	IF Output (Single Ended)
AFC Out	To Upconverter Oscillator Tuning Circuit
LO In	Synthesizer RF _v LO Input

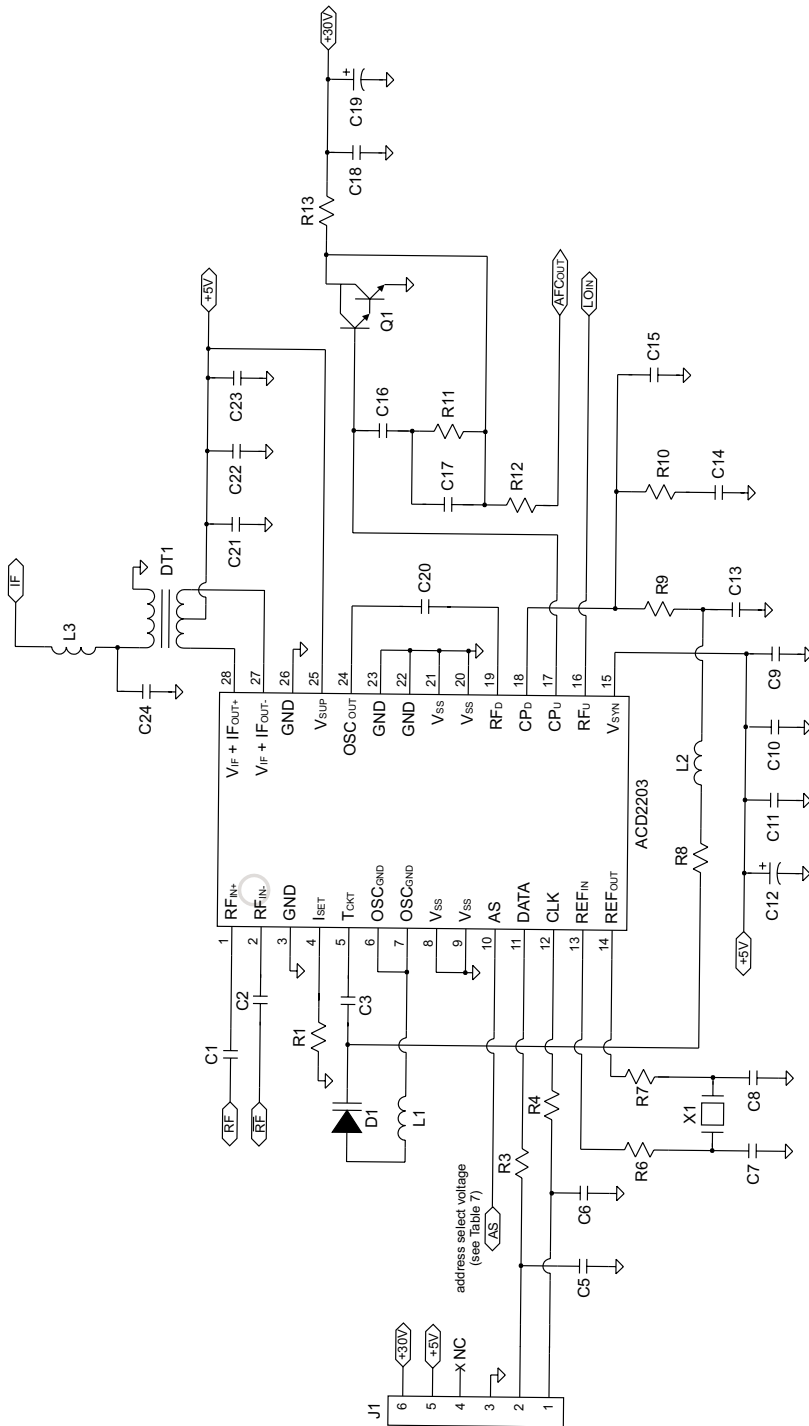

Figure 28: Evaluation Fixture Schematic

Table 21: Evaluation Fixture Parts List

ITEM #	VALUE	SIZE	DESCRIPTION	PART #	QTY	VENDOR
C1, C2, C20	100pF	0603	Chip-capacitor	GRM39COG101J50V	3	Murata
C3	5pF	0603	Chip-capacitor	GRM39COG050C50V	1	Murata
C7, C8	30pF	0603	Chip-capacitor	GRM39COG300J50V	2	Murata
C12	220uF	10V VA Series	Capacitor	PCE2040CT-ND	1	DIGI-KEY
C9, C11, C14, C21, C22	.1uF	0603	Chip-capacitor	GRM39Y5V104Z16V	5	Murata
C10, C23	1000pF	0603	Chip-capacitor	GRM39X7R102K50V	2	Murata
C15, C17	4700pF	0603	Chip-capacitor	GRM39X7R472K25V	2	Murata
C16	1uF	0603	Radial-lead Chip-capacitor	RPE113-X7R-105-K-050	1	Murata
C18	.01uF	0603	Chip-capacitor	GRM39X7R103K25V	1	Murata
C19	10uF	35 V TANT	TE Series Cap.	PCS6106CT-ND	1	DIGI-KEY
C24	15pF	0603	Chip-capacitor	GRM39COG150J50V	1	Murata
C13	5600pF	0603	Chip-capacitor	GRM39X7R562K50V	1	Murata
C5, C6	33pF	0603	Chip-capacitor	GRM39COG330J50V	2	Murata
R8	51	0603	Chip Resistor	ERJ-3GSYJ510	1	Panasonic
R1	10	0603	Chip Resistor	ERJ-3GSYJ100	1	Panasonic
R3, R4	2K	0603	Chip Resistor	ERJ-3GSYJ202	2	Panasonic
R12	1K	0603	Chip Resistor	ERJ-3GSYJ102	1	Panasonic
R11	2.7K	0603	Chip Resistor	ERJ-3GSYJ272	1	Panasonic
R7	3K	0603	Chip Resistor	ERJ-3GSYJ302	1	Panasonic
R13	22K	0603	Chip Resistor	ERJ-3GSYJ223	1	Panasonic
R10	8.2K	0603	Chip Resistor	ERJ-3GSYJ822	1	Panasonic
R6, R9	0	0603	Chip Resistor	ZC0603	2	RCD
L1	6.8nH	0805	Inductor	0805CS-060X-BC	1	Coilcraft

Table 21: Evaluation Fixture Parts List continued

ITEM #	VALUE	SIZE	DESCRIPTION	PART #	QTY	VENDOR
L2	68nH	0805	Inductor	0805CS-680X-BC	1	Coilcraft
L3	270nH	0805	Inductor	0805CS-271X-BC	1	Coilcraft
D1	1SV245		Varactor diode	1SV245	1	Toshiba
DT1	4:1		Transformer	ETC4-1-2	1	M/A-COM, Inc. North America
Q1	30V SMD	SOT-23	Transistor NPN Darl.	FMMTA13CT-ND	1	DIGI-KEY
X1	4MHZ		Crystal	SE2618CT-ND	1	DIGI-KEY

PACKAGE OUTLINE

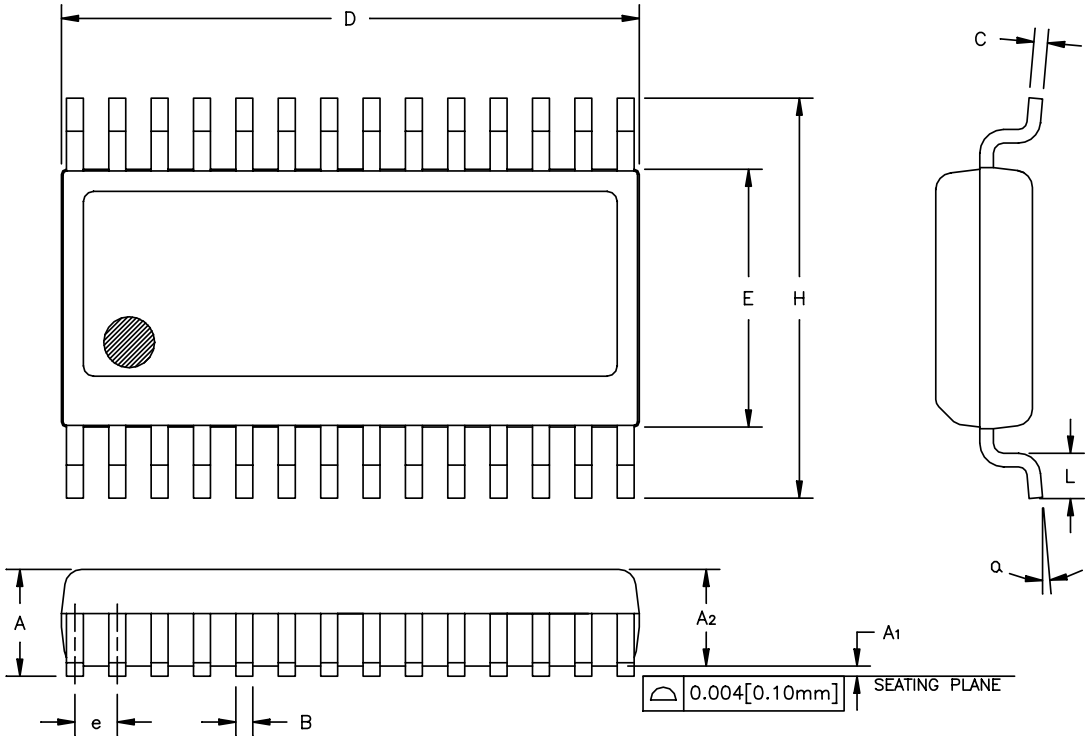

SYMBOL	INCHES		MILLIMETERS		NOTE
	MIN.	MAX.	MIN.	MAX.	
A	0.053	0.069	1.35	1.75	
A1	0.004	0.010	0.10	0.25	
A2	—	0.059	—	1.50	
B	0.008	0.012	0.20	0.30	
C	0.007	0.010	0.18	0.25	
D	0.386	0.394	9.80	10.00	2
E	0.150	0.157	3.81	3.98	3
e	0.025 BSC		0.64 BSC		4
H	0.228	0.244	5.79	6.19	
L	0.016	0.050	0.40	1.27	
α	0°	8°	0°	8°	

NOTES:

1. CONTROLLING DIMENSION: INCHES
2. DIMENSION "D" DOES NOT INCLUDE MOLD FLASH, PROTRUSIONS OR GATE BURRS. MOLD FLASH, PROTRUSIONS AND GATE BURRS SHALL NOT EXCEED 0.006 [0.15mm] PER SIDE.
3. DIMENSION "E" DOES NOT INCLUDE INTER-LEAD FLASH OR PROTRUSIONS. INTER-LEAD FLASH AND PROTRUSIONS SHALL NOT EXCEED 0.010 [0.25mm] PER SIDE.
4. MAXIMUM LEAD TWIST/SKEW TO BE ±0.0035 [0.089mm].
5. REFERENCE JEDEC MO-137 AF.

Figure 29: S8 Package Outline - 28 Pin SSOP

NOTES

ORDERING INFORMATION

ORDER NUMBER	TEMPERATURE RANGE	PACKAGE DESCRIPTION	COMPONENT PACKAGING
ACD2203S8P1	-40°C to +85°C	28 Pin SSOP	Tape & Reel, 3500 pieces per reel
ACD2203S8P0	-40°C to +85°C	28 Pin SSOP	Tubes, 50 pieces per tube
ACD2203S8GP1	-40°C to +85°C	Lead-free 28 Pin SSOP	Tape & Reel, 3500 pieces per reel
ACD2203S8GP0	-40°C to +85°C	Lead-free 28 Pin SSOP	Tubes, 50 pieces per tube



ANADIGICS, Inc.

141 Mount Bethel Road

Warren, New Jersey 07059, U.S.A

Tel: +1 (908) 668-5000

Fax: +1 (908) 668-5132

URL: <http://www.anadigics.com>

E-mail: Mktg@anadigics.com

IMPORTANT NOTICE

ANADIGICS, Inc. reserves the right to make changes to its products or to discontinue any product at any time without notice. The product specifications contained in Advanced Product Information sheets and Preliminary Data Sheets are subject to change prior to a product's formal introduction. Information in Data Sheets have been carefully checked and are assumed to be reliable; however, ANADIGICS assumes no responsibilities for inaccuracies. ANADIGICS strongly urges customers to verify that the information they are using is current before placing orders.

WARNING

ANADIGICS products are not intended for use in life support appliances, devices, or systems. Use of an ANADIGICS product in any such application without written consent is prohibited.