



ANALOG ICs

*33395 EVALUATION
MOTOR BOARD
DESIGNER REFERENCE
MANUAL*

DRM33395/D
Rev. 2
05/2003

Freescale Semiconductor, Inc.

POWER

EMBEDDED MOTION CONTROL



*Communicate
Control
Protect*

**For More Information On This Product,
Go to: www.freescale.com**

List of Sections

Section 1. Introduction and Setup 9

Section 2. Operational Description 15

Section 3. Pin Descriptions 17

Section 4. Schematics and Parts List 25

Section 5. Design Considerations 37

Table of Contents

Section 1. Introduction and Setup

1.1	Contents	9
1.2	SMOS EVM Motor Board Introduction.....	9
1.3	About This Manual.....	9
1.4	Warnings	12
1.5	Setup Guide.....	13

Section 2. Operational Description

2.1	Contents	15
2.2	Introduction.....	15
2.3	Electrical Characteristics	16

Section 3. Pin Descriptions

3.1	Contents	17
3.2	Introduction	17
3.3	Signal Descriptions.....	19
3.3.1	Power Connectors J3 and JP4.....	19
3.3.2	40-Pin Ribbon Connector J1	19
3.3.3	Output Connectors: J2, J4, FASTONS (J5, J7, J8).....	22
3.3.4	Jumpers and Switch/Push Button: M0, M1, PWM, SW1	22
3.3.5	Test Points	24

Section 4. Schematics and Parts List

4.1 Contents 25

4.2 Overview..... 25

4.3 Schematics 25

4.4 Parts List..... 32

Section 5. Design Considerations

5.1 Contents 37

5.2 Overview..... 37

5.3 3-Phase H-Bridge 37

5.4 Bus Voltage and Current Feedback Signals..... 38

5.5 Back-EMF Signals 40

5.6 Brake Control..... 41

List of Figures

Figure	Title	Page
1-1	System Configurations.....	10
1-2	SMOS EVM Motor Board ver. 140A01	11
1-3	SMOS EVM Motor Board Setup	14
3-1	40-Pin Input Connector J1	18
4-1	SMOS EVM Motor Board ver. 140A01 Overview	26
4-1a	SMOS EVM Motor Board ver. 140A02 Overview	27
4-2	3-Phase H-Bridge with Gate Driver	28
4-3	Current Feedback Circuits	29
4-4	Back-EMF Signals	30
4-5	Brake Control.....	31
4-6	Brushless DC Motor Connections - Schematic View	31
5-1	Phase Current and DC Bus Voltage Sensing	39
5-2	Reconstructed Bus Current	40
5-3	Phase C Back-EMF Feedback	40

33395 Evaluation Motor Board

List of Tables

Table	Title	Page
2-1	Electrical Characteristics	16
3-1	Connector J1 Signal Descriptions	19
3-2	Connectors J2 and J4 Signal Descriptions	22
3-3	Driver Jumper Groups for Operating Mode	22
3-4	Gate Driver PWM Signal Selection	23
3-5	Test Points	24
4-1	Parts List.....	32

Section 1. Introduction and Setup

1.1 Contents

1.2	SMOS EVM Motor Board Introduction.....	9
1.3	About This Manual.....	9
1.4	Warnings	12
1.5	Setup Guide.....	13

1.2 SMOS EVM Motor Board Introduction

Motorola's SMARTMOS™ 33395 evaluation motor board (SMOS EVM motor board) is a 12-volt, 8-amp power stage that is an integral part of Motorola's embedded motion control series of development tools. It is also supplied as a kit. In combination with one of the embedded motion-control series control or evaluation boards, it provides a ready-made development platform for brushless dc motors. The motor can be controlled using Hall sensors, an optical encoder or sensorless techniques. An illustration of system configurations is shown in [Figure 1-1](#). [Figure 1-2](#) depicts the board layout.

1.3 About This Manual

Key items can be found in the following locations in this manual:

- Setup instructions are found in chapter [1.5](#).
- Schematics are found in chapter [4.3](#).
- Pin assignments are shown in [Figure 3-1](#), and a pin-by-pin description is contained in chapter [3.3](#).
- For those interested in the reference design aspects of the board's circuitry, a description is provided in [Section 5](#).

Introduction and Setup

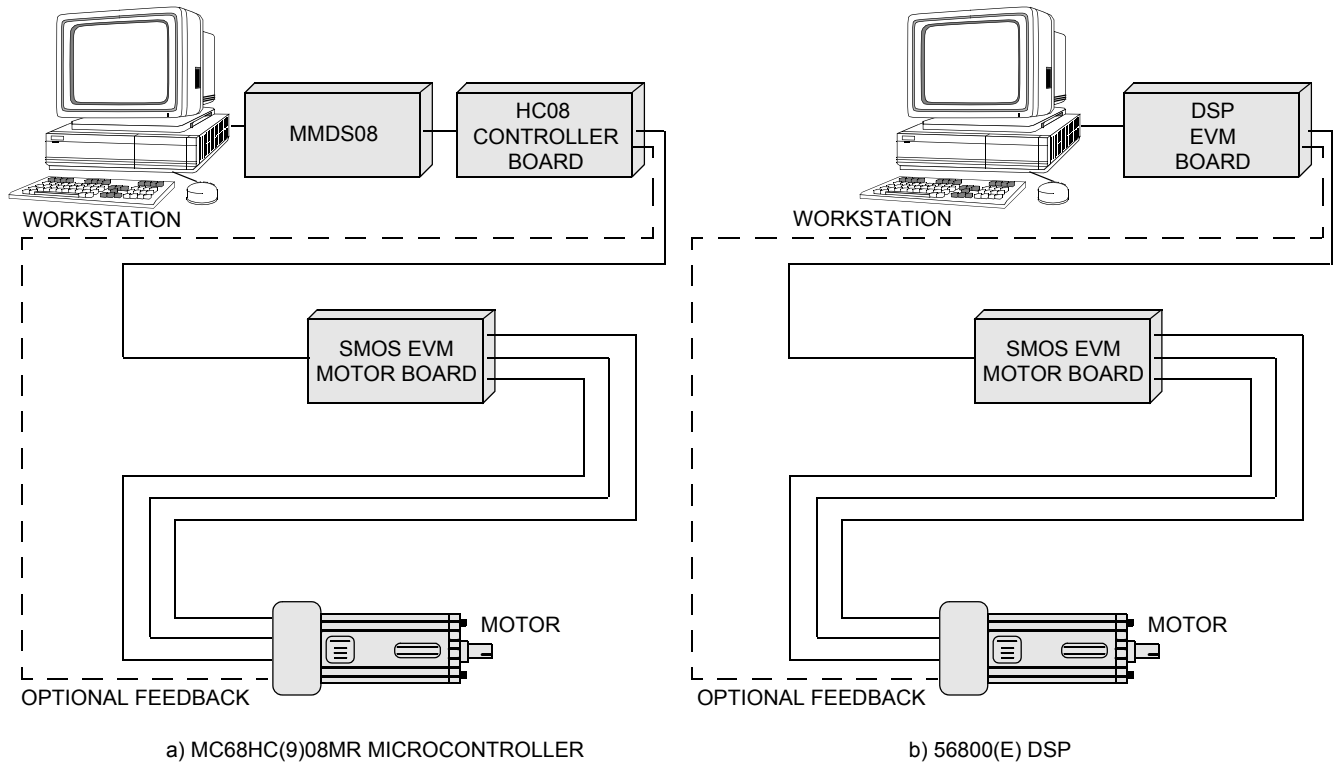

Figure 1-1 System Configurations

Freescale Semiconductor, Inc.

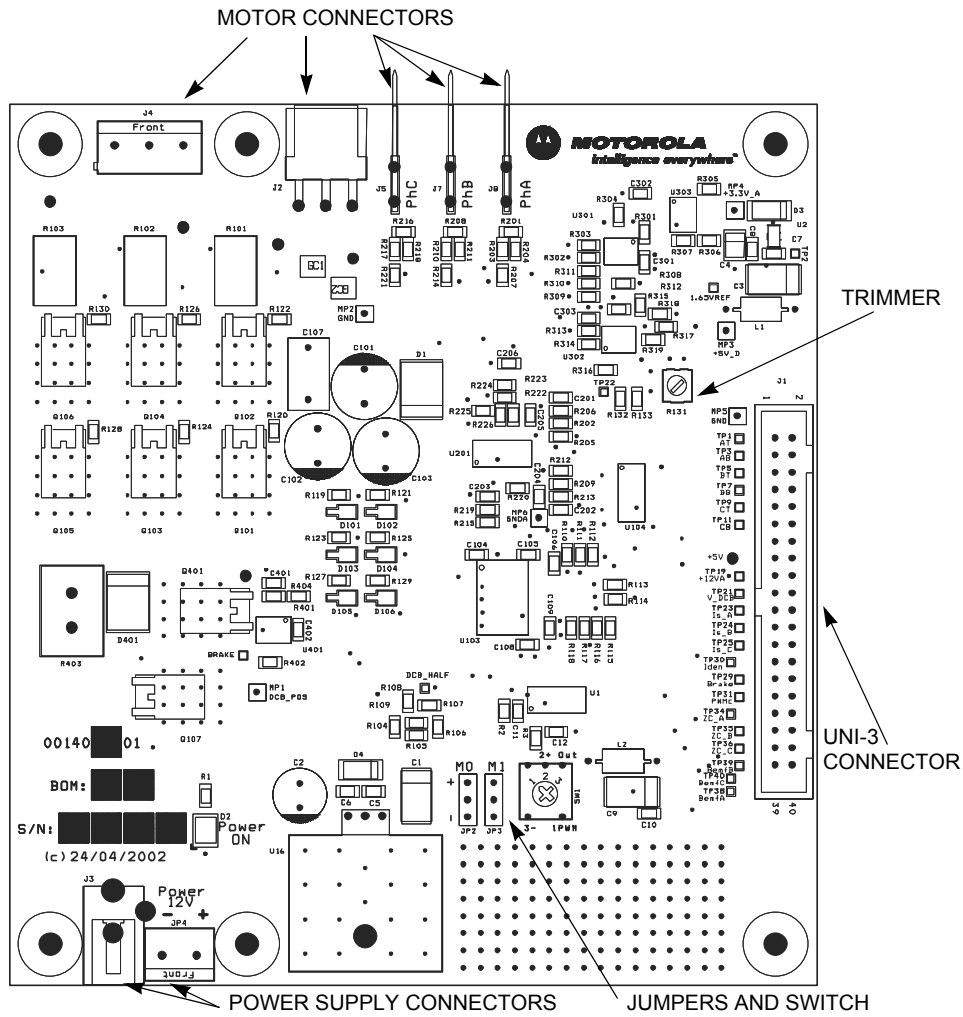

Figure 1-2 SMOS EVM Motor Board ver. 140A01

1.4 Warnings

The SMOS EVM motor board kit includes a rotating machine and power transistors. Both can reach temperatures hot enough to cause burns! To facilitate safe operation, 12-volt input power should come from a dc laboratory power supply that is current limited to no more than 10 amps.

The user should be aware that:

- Before moving scope probes, making connections, etc., it is generally advisable to power down the 12-volt supply.
- Standalone operation of the board should be allowed only with use of an insulative pad or standoffs as shown in **Figure 1-3**.
- Wearing safety glasses, avoiding neckties and jewelry, using shields, and operation by personnel trained in power electronics lab techniques are also advisable.

1.5 Setup Guide

Setup and connections for the SMOS EVM motor board are straightforward. The SMOS EVM motor board connects to a Motorola embedded motion control series control board via a 40-pin ribbon cable. The motor's power leads plug into one of the output connectors J2 or J4 or FASTON type (J5 J7 J8). **Figure 1-3** depicts a completed setup with control board or module.

Follow these steps to set up the board:

1. Mount 4 standoffs to the SMOS EVM motor board at the locations indicated in **Figure 1-3**. Step 1 and step 3 are optional when making connections to DSP control boards such as the DSP56F8xxEVM that can be placed flat on a bench next to the SMOS EVM motor board.
2. Plug one end of the 40-pin ribbon cable that is supplied with Motorola embedded motion control series control boards into input connector J1, located on the right-hand side of the motor board, considering its '*default front view*' position as in **Figure 1-2**. The other end of this cable links to the control board's 40-pin output connector.
3. Mount the control board on top of the standoffs with screws and washers. This step is optional with DSP control boards.
4. Connect a 12-Vdc power supply either to connector J3 or power jack JP4, labeled "Power 12V". Either one, but not both, can be used. These connectors are located on the front left-hand corner of the board. The 12-volt power supply should be rated to match the motor current.
5. Apply power to the SMOS EVM motor board. The green power-on LED lights when the voltage supply is present. Note that the SMOS EVM motor board powers the control board as well.

CAUTION: *Since the control board is powered by the SMOS EVM motor board, it is imperative that only one power supply is used!*

6. Temperature, under-voltage or over-voltage faults, or externally sensed bus current overflow disables the gate driver. Board reset is needed. Either switch the power supply off and on or provide a '*soft reset*'. To provide the soft reset on the 140A01 board version, toggle the SW1 switch from position 3 to 2; on the 140A02 version, press the RESET button. Refer to chapter **3.3.4** to verify the jumper positions.

NOTE: *Check if the trimmer tagged in **Figure 1-2** is set to <2.45V (between bottom trimmer pin-2, R131 label, and GNDA) which thresholds the dc bus current to 10 amps. The closer its value is set to 1.65V, the smaller the bridge current is that can flow.*

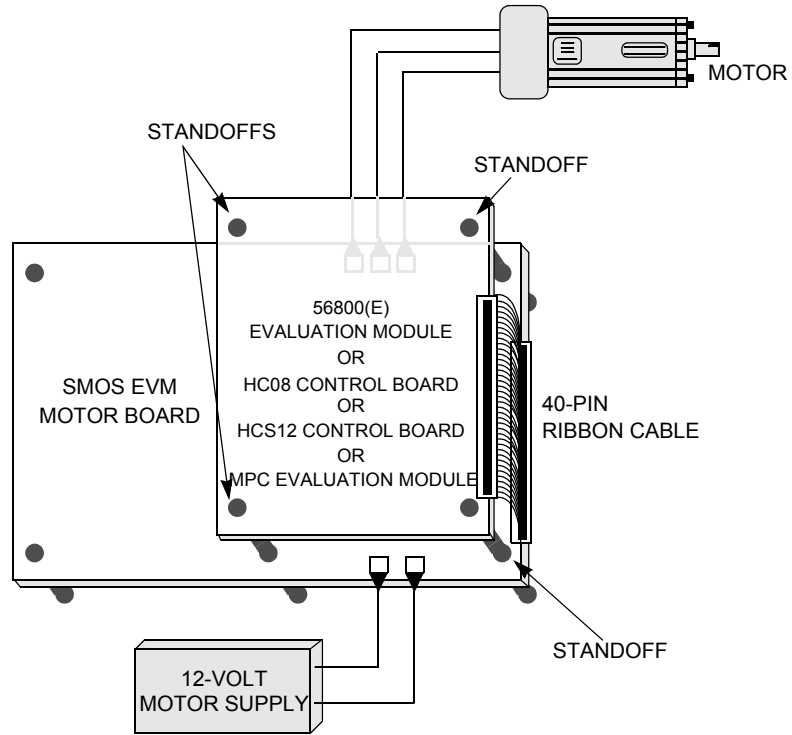

Figure 1-3 SMOS EVM Motor Board Setup

Section 2. Operational Description

2.1 Contents

2.2	Introduction	15
2.3	Electrical Characteristics	16

2.2 Introduction

Motorola's embedded motion control series SMOS EVM motor board is a 12-volt, 8-amp, surface-mount power stage with an analog SMOS driver. In combination with one of the embedded motion control series control boards, it provides a development platform that allows algorithms to be written and tested without the need to design and build a power stage. It supports algorithms that use Hall sensors, encoder feedback, and Back-EMF (electromotive force) signals for sensorless control.

The SMOS EVM motor board has an over-current protection that is independent of the control board, yet some care in its setup and use is required for board or motor protection. Current-measuring circuitry is set up for 8 amps full scale, according to trimmer position. A 25°C ambient temperature operation with output current up to 10 amps of continuous RMS value is within the board's thermal limits. Note that there is no thermal protection provided on the board.

Input connections are made via a 40-pin ribbon cable connector J1. Pin assignments for the input connector are shown in **Figure 3-1**. Power connections to the motor are made on one of the output connectors J2 or J4 or FASTON type (J5 J7 J8). Phase A (J8), phase B (J7), and phase C (J5) are labeled on the board, the phase pin order for all three connector types is identical. Power requirements are met by a single external 12-Vdc power supply. Two connectors, labeled J3 and JP4, are

Operational Description

provided for the 12-volt power supply; they are located on the front edge of the board. Power is supplied to one or the other, but not both.

A summary of the information needed to use the SMOS EVM motor board follows. For design information, see [Section 5](#).

2.3 Electrical Characteristics

The electrical characteristics in [Table 2-1](#) apply to operation at 25°C and a 12-Vdc power supply voltage.

Table 2-1 Electrical Characteristics

Characteristic	Symbol	Min	Typ	Max	Units
Power Supply Voltage	Vdc	10.2	12	16	V
Quiescent Current	I _{CC}	—	70	—	mA
High State Logic 1 Input Voltage	V _{IH}	2.4	3.3 or 5	7	V
Low State Logic 0 Input Voltage	V _{IL}	—	< 0.4	0.8	V
Input Resistance	R _{In}	—	10	—	kΩ
Analog Output Range	V _{Out}	0	—	3.3	V
Phase Current Sense Voltage	I _{Sense}	—	172	—	mV/A
Bus Voltage Sense Voltage	V _{Bus}	—	206	—	mV/V
Power MOSFET On Resistance	R _{DS(On)}	—	10	16	mΩ
RMS Output Current	I _M	—	—	10	A
Total Power Dissipation	P _{diss}	—	—	18	W

Section 3. Pin Descriptions

3.1 Contents

3.2	Introduction	17
3.3	Signal Descriptions	19
3.3.1	Power Connectors J3 and JP4	19
3.3.2	40-Pin Ribbon Connector J1	19
3.3.3	Output Connectors: J2, J4, FASTONS (J5, J7, J8)	22
3.3.4	Jumpers and Switch/Push Button: M0, M1, PWM, SW1	22
3.3.5	Test Points	24

3.2 Introduction

Inputs and outputs are located on six board connectors depicted in **Figure 1-2**:

- There are three motor connectors conducting identical output signals, however only one motor can be connected at run time to one of these connectors.
- There are two power supply connectors which introduce identical input signals, however only one power supply can be plugged in at run time to one of these connectors.
- One connector (UNI-3) is associated with the controller board.

In addition, many test points are located on the SMOS EVM motor board.

Pin descriptions for each of these connectors and the test points are identified in the following information. Pin assignments for the input and

Pin Descriptions

output connectors are shown in **Figure 3-1** with their descriptions in **Table 3-1** through **Table 3-5**.

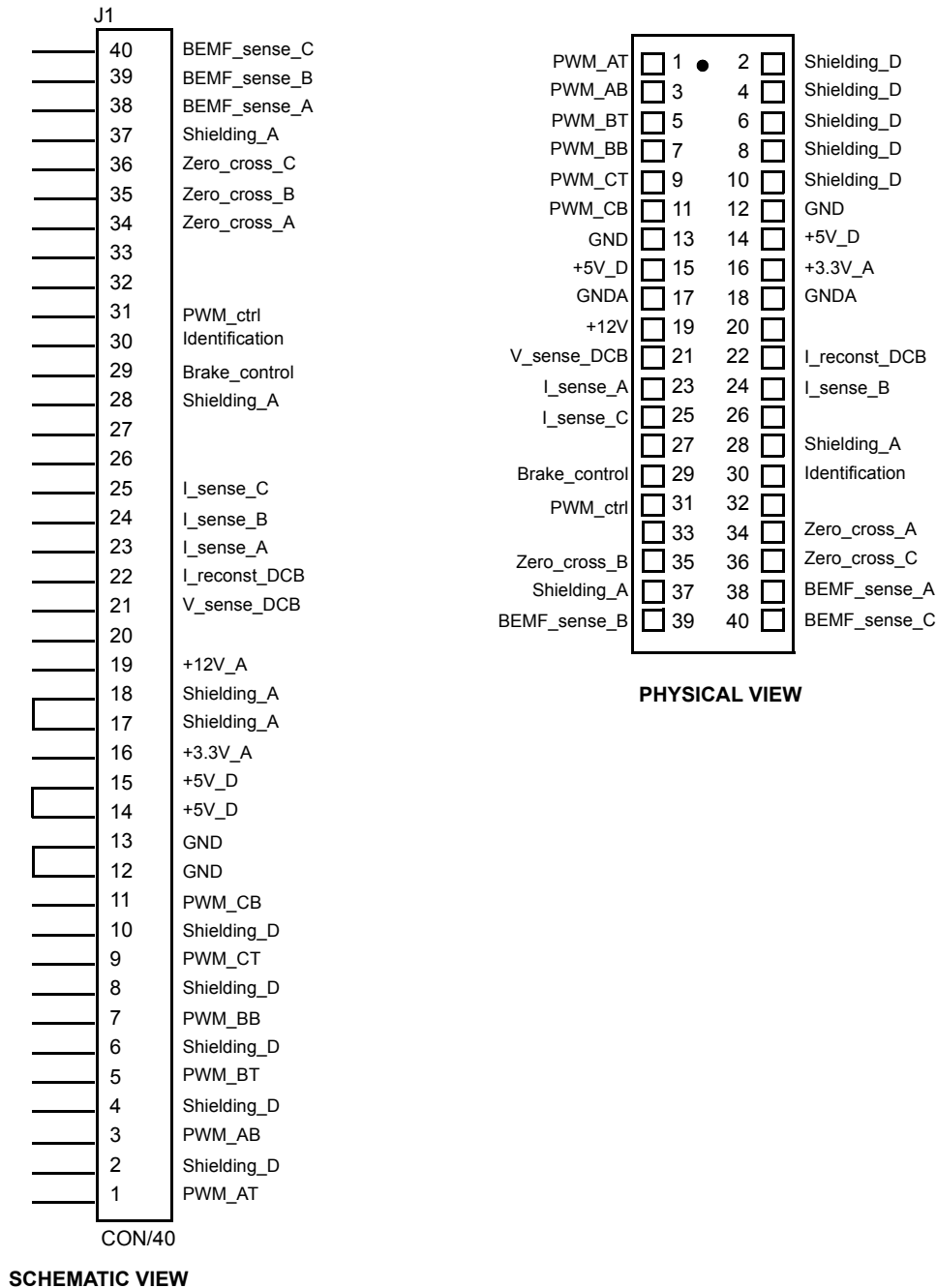

Figure 3-1 40-Pin Input Connector J1

3.3 Signal Descriptions

Pin descriptions are identified in this subsection.

3.3.1 Power Connectors J3 and JP4

Two connectors, labeled J3 and JP4, are provided for the 12-volt power supply. They are located on the bottom left-hand corner of the board. Connector J3 is a 2.5-mm power jack for plug-in type 12-volt power supply connections. Connector JP4 has screw terminal inputs labeled + (plus) and – (minus), for accepting wire inputs. Power is supplied to one or the other, but not both. The power supply required parameters depend on the motor type used. The default output current limit of the board is 10 amps.

3.3.2 40-Pin Ribbon Connector J1

Signal inputs are grouped together on 40-pin ribbon cable connector J1, located on the right side of the board. Pin assignments are shown in [Figure 3-1](#). Pin descriptions are listed in [Table 3-1](#).

Table 3-1 Connector J1 Signal Descriptions (Sheet 1 of 3)

Pin No.	Signal Name	Description
1	PWM_AT	PWM_AT is the gate drive signal for the top half-bridge of phase A. A logic high at input connector J1 turns on the phase A top switch.
2	Shielding_D	Pin 2 is connected to a shield wire in the ribbon cable and ground on the board.
3	PWM_AB	PWM_AB is the gate drive signal for the bottom half-bridge of phase A. A logic high at input connector J1 turns on the phase A bottom switch.
4	Shielding_D	Pin 4 is connected to a shield wire in the ribbon cable and ground on the board.
5	PWM_BT	PWM_BT is the gate drive signal for the top half-bridge of phase B. A logic high at input connector J1 turns on the phase B top switch.
6	Shielding_D	Pin 6 is connected to a shield wire in the ribbon cable and ground on the board.
7	PWM_BB	PWM_BB is the gate drive signal for the bottom half-bridge of phase B. A logic high at input connector J1 turns on the phase B bottom switch.
8	Shielding_D	Pin 8 is connected to a shield wire in the ribbon cable and ground on the board.

Pin Descriptions

Table 3-1 Connector J1 Signal Descriptions (Sheet 2 of 3)

Pin No.	Signal Name	Description
9	PWM_CT	PWM_CT is the gate drive signal for the top half-bridge of phase C. A logic high at input connector J1 turns on the phase C top switch.
10	Shielding_D	Pin 10 is connected to a shield wire in the ribbon cable and ground on the board.
11	PWM_CB	PWM_CB is the gate drive signal for the bottom half-bridge of phase C. A logic high at input connector J1 turns on the phase C bottom switch.
12	GND	Digital power supply ground
13	GND	Digital power supply ground, redundant connection
14	+5V_D	Digital +5-volt power supply
15	+5V_D	Digital +5-volt power supply, redundant connection
16	+3.3V_A	Analog +3.3-volt power supply
17	GND_A	Analog power supply ground
18	GND_A	Analog power supply ground, redundant connection
19	+12V	+12-volt power supply
20	—	No connection
21	V_sense_DCB	V_sense_DCB is an analog sense signal that measures dc bus voltage. It is scaled at 0.206 volts per volt of dc bus voltage.
22	I_reconst_DCB	I_reconst_DCB is an analog sense signal that measures dc bus current. It is scaled at 0.172 volts per amp of dc bus current.
23	I_sense_A	I_sense_A is an analog sense signal that measures current in phase A. It is scaled at 0.172 volts per amp of dc bus current.
24	I_sense_B	I_sense_B is an analog sense signal that measures current in phase B. It is scaled at 0.172 volts per amp of dc bus current.
25	I_sense_C	I_sense_C is an analog sense signal that measures current in phase C. It is scaled at 0.172 volts per amp of dc bus current.
26	—	No connection
27	—	No connection
28	Shielding_A	Pin 28 is connected to a shield wire in the ribbon cable and ground on the board.
29	Brake_control	Brake_control is the gate drive digital signal for the brake MOSFET.
30	Identification	This is an identification signal that lets the controller know which power stage is present. It is nominally a 1.5kHz square wave.

Table 3-1 Connector J1 Signal Descriptions (Sheet 3 of 3)

Pin No.	Signal Name	Description
31	PWM_ctrl	This is a gate drive digital signal that is used for power stage board control with use of just one PWM input signal switching according to gate drive signals PWM_xx
32	—	No connection
33	—	No connection
34	Zero_cross_A	Zero_cross_A is a digital signal that is used for sensing phase A back-EMF zero crossing events.
35	Zero_cross_B	Zero_cross_B is a digital signal that is used for sensing phase B back-EMF zero crossing events.
36	Zero_cross_C	Zero_cross_C is a digital signal that is used for sensing phase C back-EMF zero crossing events.
37	Shielding_A	Pin 37 is connected to a shield wire in the ribbon cable and ground on the board.
38	BEMF_sense_A	BEMF_sense_A is an analog sense signal that measures phase A Back-EMF. It is scaled at 0.206 volts per volt of dc bus voltage.
39	BEMF_sense_B	BEMF_sense_B is an analog sense signal that measures phase B Back-EMF. It is scaled at 0.206 volts per volt of dc bus voltage.
40	BEMF_sense_C	BEMF_sense_A is an analog sense signal that measures phase C Back-EMF. It is scaled at 0.206 volts per volt of dc bus voltage.

3.3.3 Output Connectors: J2, J4, FASTONS (J5, J7, J8)

Power output to the motor is located on connectors J2, J4 and FASTONS (J5, J7, J8). Pin assignments are described in [Table 3-2](#). FASTON type connectors are labelled with PhA (connector J8) for phase A, PhB (J7) for phase B, and PhC (J5) for phase C. Phase order is identical for all three connectors. Note that wire color may vary with different motor types.

Table 3-2 Connectors J2 and J4 Signal Descriptions

Pin No.	Signal Name	FASTON Pin Name	Description
1	Phase_A	J8	Phase_A supplies power to motor phase A.
2	Phase_B	J7	Phase_B supplies power to motor phase B.
3	Phase_C	J5	Phase_C supplies power to motor phase C.

3.3.4 Jumpers and Switch/Push Button: M0, M1, PWM, SW1

The jumper groups M0 (JP2) and M1 (JP3) are used to select the operating mode of the SMOS gate driver (see [Table 3-3](#)). For the truth table of the driver, see its data sheet.

Table 3-3 Driver Jumper Groups for Operating Mode

M0 (JP2)	M1 (JP3)	Comment
+ position	+ position	High state logic 1
- position	- position	Low state logic 0 (default)

For selection of the PWM signal brought to the gate driver, the 140A01 board version uses the SW1 rotary switch and the 140A02 version uses the PWM (JP5) jumper group and RESET (SW1) push button. Both solutions have the same behavior (see [Table 3-4](#) for an explanation).

When one PWM signal is sent from the controller board to the motor board through the UNI-3 interface, the SMOS driver must multiplex it between the three phases according to the mode defined by M0 and M1. The mode selection is not needed when six PWM signals are generated.

Table 3-4 Gate Driver PWM Signal Selection

SW1 Rotary Switch on 140A01 board	Representation on 140A02 board	Comment
Position 1 (1PWM pin)	JP5 jumper uni position	Controller board gives 1 PWM signal
Position 2 (2+ pin)	JP5 jumper + position	High state logic 1 (6 PWM signals, default)
Position 3 (3- pin)	SW1 button press (RESET)	Resets drive off status (temporary)

NOTE: *The gate driver ‘soft reset’ is necessary to leave the drive off status that is not entered by default. When a fault arises or a parallel cable that is connected between a computer and the controller board introduces an obscure voltage from this computer into the motor system, the reset assures correct driver re-initialization. The soft reset is activated either by toggling the SW1 rotary switch from position 3 to 2 (140A01 board version), or by resetting with the SW1 push button (140A02 version). Then the board generates a resetting pulse on the driver PWM_IN pin.*

Pin Descriptions

3.3.5 Test Points

Ten test points provide easy access to the power supply, reference voltages and other circuits. They are listed in [Table 3-5](#) with their descriptions and locations. Additional test points appearing left of the UNI-3 connector are numbered adequately to UNI-3 pin numbers and explained in [Table 3-1](#).

Table 3-5 Test Points

Point No.	Signal Name	The Test/Measurement point is connected to:	Location
1	DCB_POS (MP1)	the +12-volt motor bus	above green LED diode
2	GND (MP2)	the 12-volt power supply and motor bus ground	below J2 - motor connector
3	+5V_D (MP3)	the 5-volt digital power supply voltage	above UNI-3 connector
4	+3.3V_A (MP4)	the 3.3-volt analog power supply voltage	on top right corner
5	GND (MP5)	the 12-volt power supply and motor bus ground	on top left side of UNI-3 connector
6	GND_A (MP6)	the analog ground	in the middle, above SMOS
7	1.65VREF	the 1.65-volt analog reference voltage	above MP3, below MP4
8	DCB_HALF	Back-EMF zero crossing circuitry	right of MP1, below SMOS
9	BRAKE	the gate of the brake's transistor	above MP1
10	I_reconst (TP22)	pin 22 of UNI-3 connector, see Table 3-1	left of trimmer and MP3

Section 4. Schematics and Parts List

4.1 Contents

4.2	Overview	25
4.3	Schematics	25
4.4	Parts List.....	32

4.2 Overview

A set of schematics for the SMOS EVM motor board appears in **Figure 4-1** up to **Figure 4-5**. An overview of the whole board is presented in **Figure 4-1** (or **Figure 4-1a**). The 3-phase H-bridge, including gate driver, is depicted in **Figure 4-2**. Current feedbacks are presented in **Figure 4-3**. Back-EMF signals are shown in **Figure 4-4**. The brake control is illustrated in **Figure 4-5**. Brushless dc motor connections are shown in **Figure 4-6**.

Unless otherwise specified, resistor values are in ohms, resistors are specified as 1/8 watt $\pm 5\%$, and interrupted lines coded with the same letters are electrically connected.

4.3 Schematics

The schematics for the SMARTMOS evaluation motor board are rendered on the following pages.

Schematics and Parts List

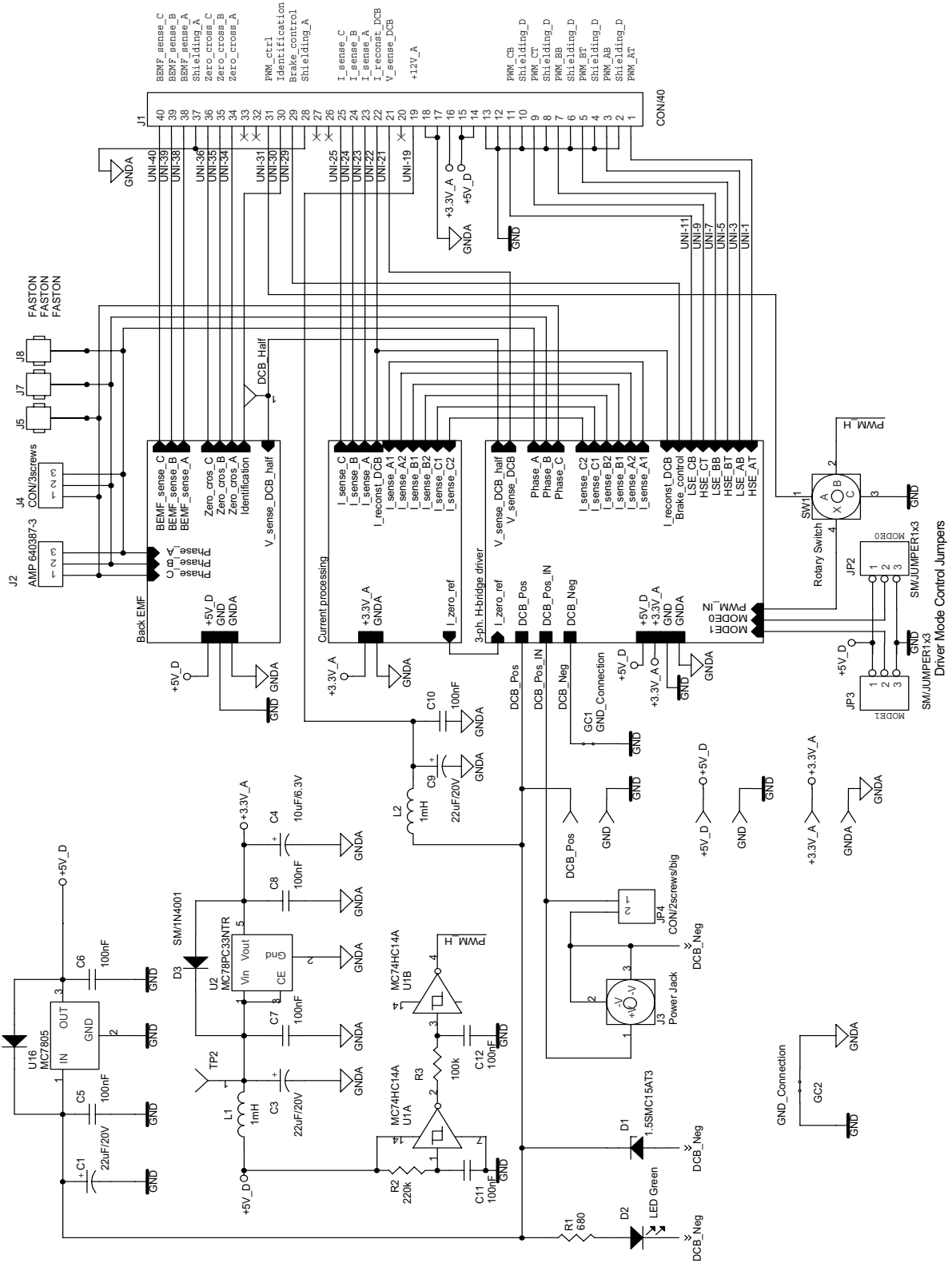

Figure 4-1 SMOS EVM Motor Board ver. 140A01 Overview

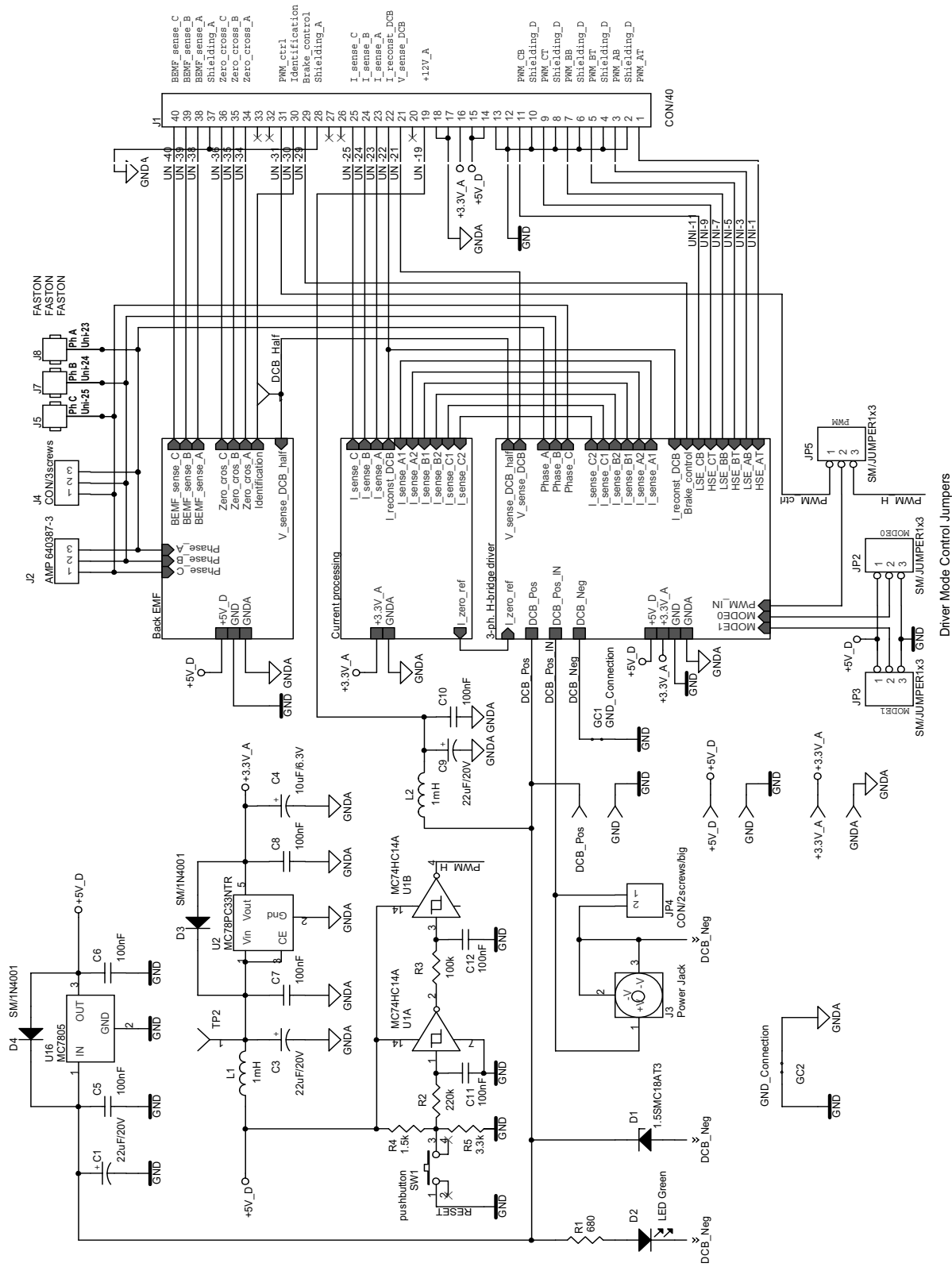

Figure 4-1a SMOS EVM Motor Board ver. 140A02 Overview

Schematics and Parts List

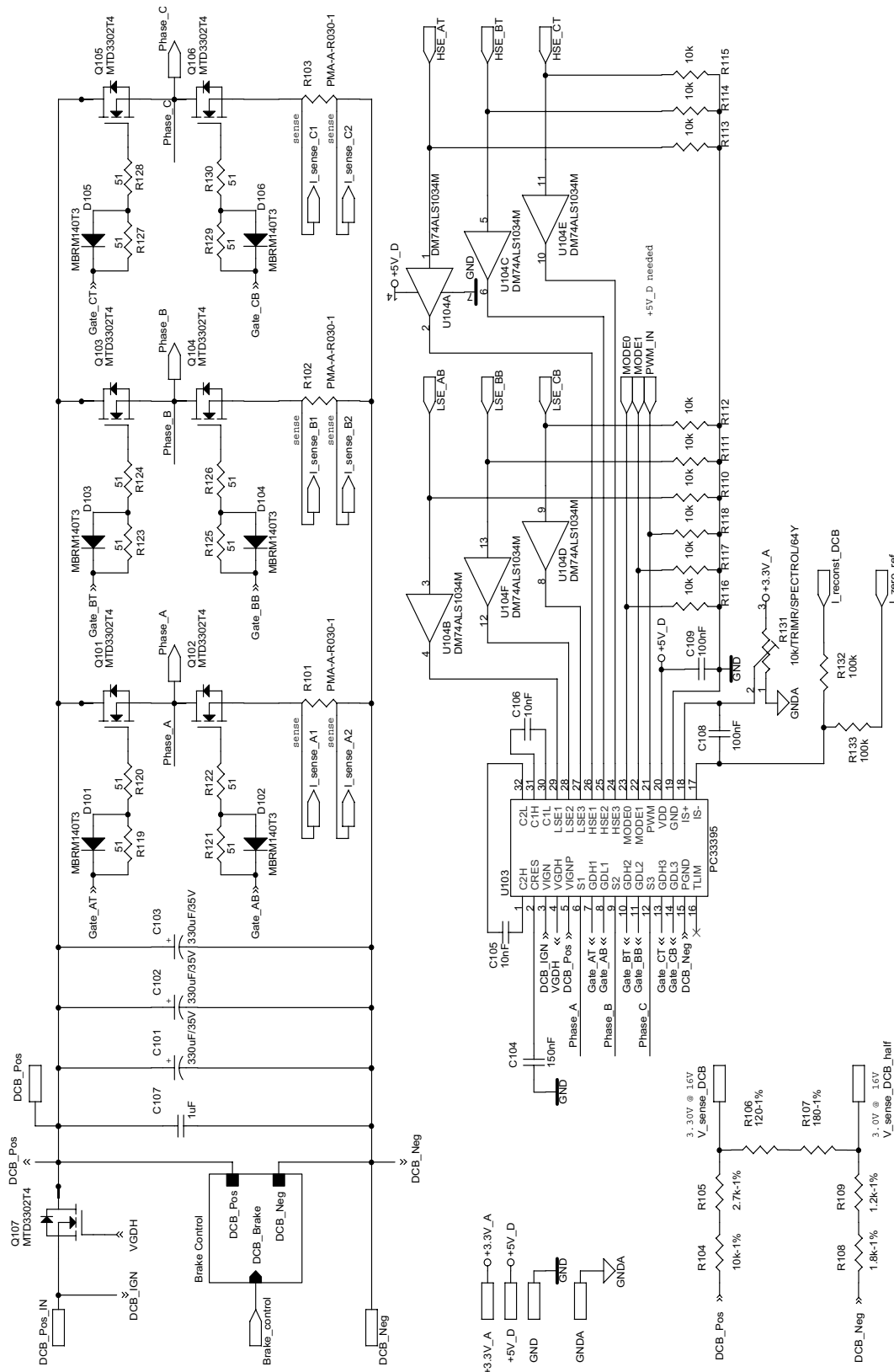

Figure 4-2 3-Phase H-Bridge with Gate Driver

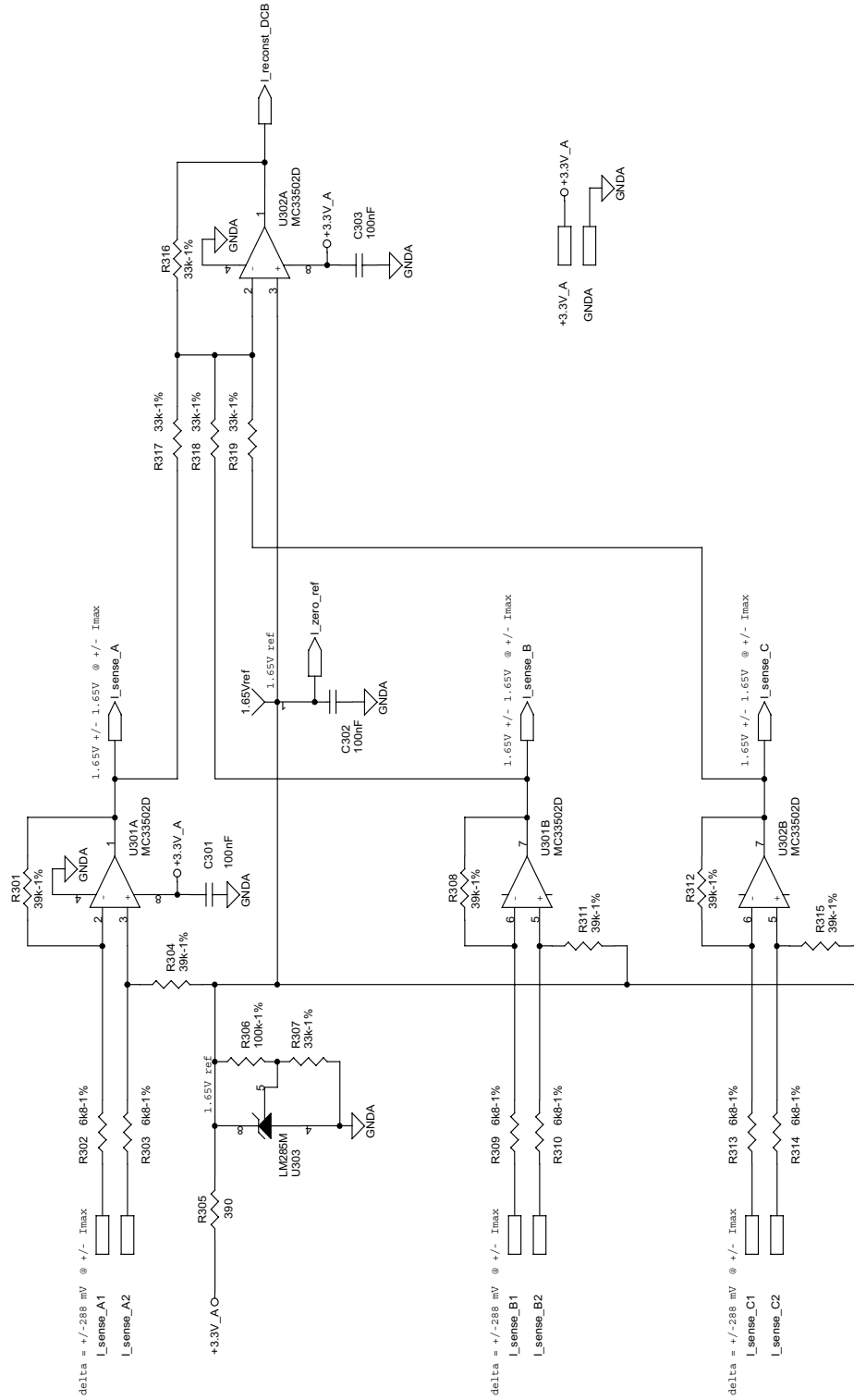

Figure 4-3 Current Feedback Circuits

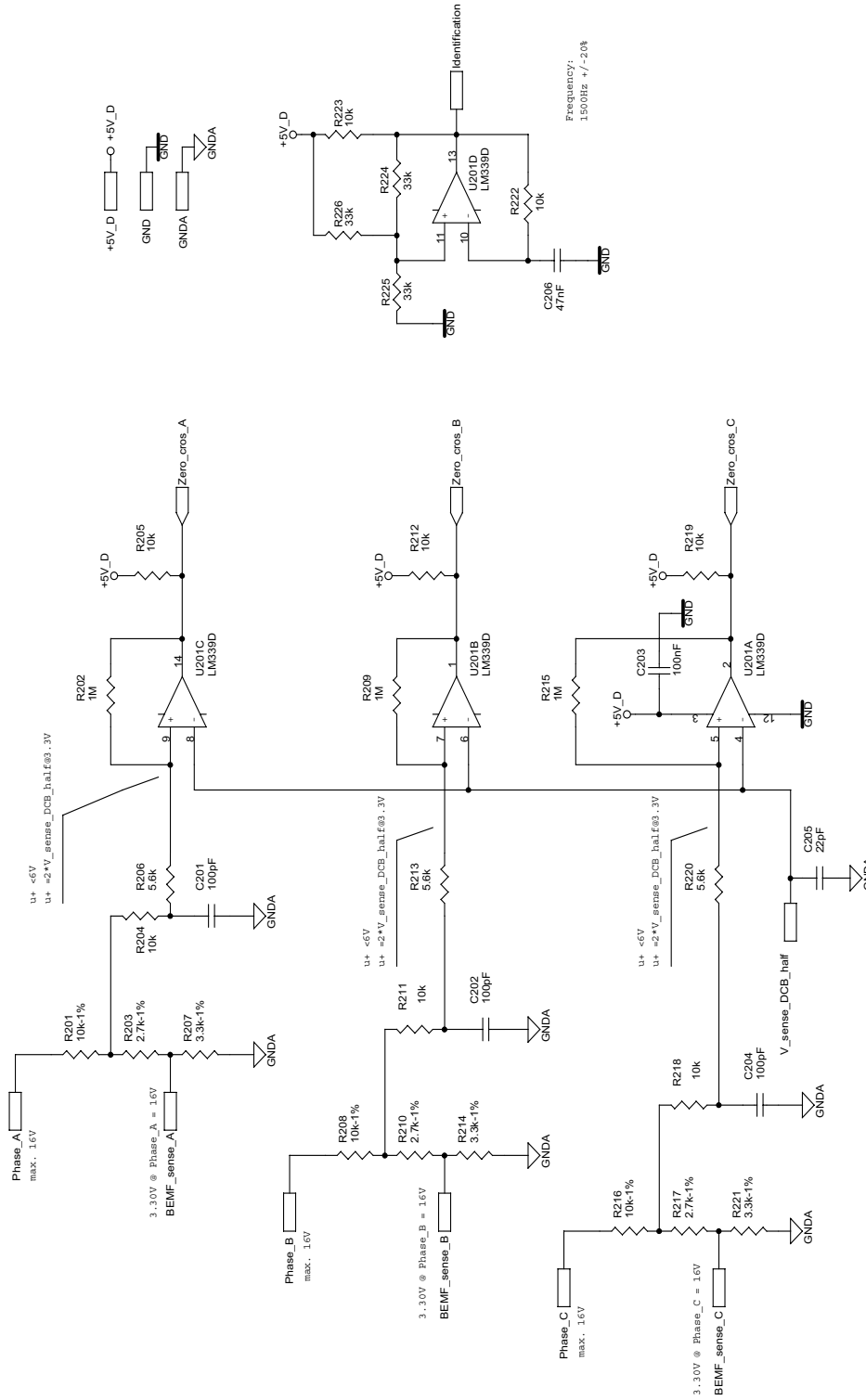

Figure 4-4 Back-EMF Signals

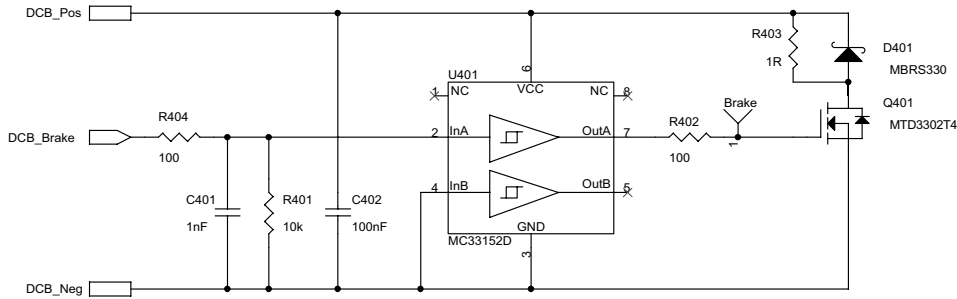

Figure 4-5 Brake Control

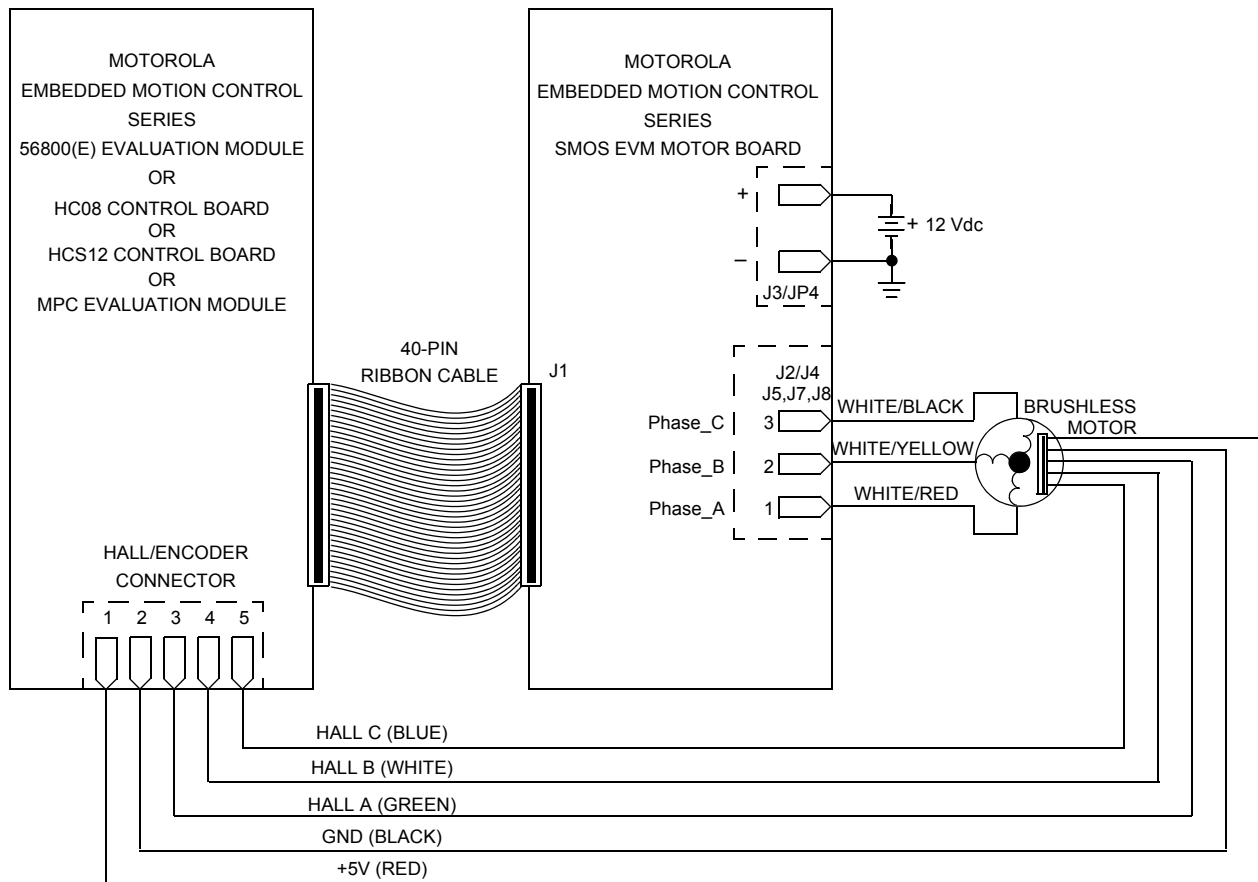

Figure 4-6 Brushless DC Motor Connections - Schematic View

4.4 Parts List

The SMOS EVM motor board's list of parts is described in the following table.

Table 4-1 Parts List (Sheet 1 of 4)

Qty.	Reference	Part Value	Description	Mfg.	Mfg. Part No.
3	C1, C3, C9	22 μ F/25 V	Tantalum capacitor, D, 22 μ F/20 V, \pm 10%, ESR 0.2	AVX	
1	C4	10 μ F/ 6.3 V	Tantalum Capacitor, A, 10 μ F/6.3 V, \pm 10%	AVX, ELNA	
14	C5, C6, C7, C8, C10, C11, C12, C108, C109, C203, C301, C302, C303, C402	100 nF	Capacitor, 0805, Ceramic 100 nF/25 V, Z5U, \pm 20%	Vishay Vitramon	
3	C101, C102, C103	330 μ F/35 V	Electrolytic Capacitor 330 μ F/35 V, Type RE2	ELNA	
1	C104	150 nF	Ceramic capacitor, 0805, 150 nF, \pm 5%	Vishay Vitramon	
2	C105, C106	10 nF	Ceramic capacitor, 0805, 10 nF, \pm 5%	Vishay Vitramon	
1	C107	1 μ F	Polyester Capacitor 1 μ F/63V, \pm 10%, Type MKT 220-7	EPCOS	
3	C201, C202, C204	100 pF	Ceramic capacitor, 0805, 100 pF, \pm 5%	Vishay Vitramon	
1	C205	22 pF	Ceramic capacitor, 0805, 22 pF, \pm 5%	Vishay Vitramon	
1	C206	47 nF	Ceramic capacitor, 0805, 47 nF, \pm 5%	Vishay Vitramon	
1	C401	1 nF	Ceramic capacitor, 0805, 1 nF, \pm 5%	Vishay Vitramon	
1	D1	1.5SMC18AT3	Zener Transient Voltage Suppressor 18V	ON Semiconductor	1.5SMC18AT3
1	D2	LED Green	LED diode, SMD, 20 mA, green	Kingbright	AA3528SGT
2	D3, D4	1N4001	General Purpose Axial Rectifier 50V, 1A	ON Semiconductor	1N4001
6	D101, D102, D103, D104, D105, D106	MBRM140T3	Shottky Rectifiers 40 V, 1A	ON Semiconductor	MBRM140T3
1	D401	MBRS330	Schottky Rectifier 30V, 3A	ON Semiconductor	MBRS330
3	JP2, JP3, JP5	JUMPER1x3	Jumper, 3-pin header, 0.1", M20-973 type	HARWIN	

Table 4-1 Parts List (Sheet 2 of 4)

Qty.	Reference	Part Value	Description	Mfg.	Mfg. Part No.
1	JP4	CON/2screws	2 screws PCB terminal, 5mm pin spacing	WAGO	237-132
1	J1	CON/40	Header 40 pins breakaway connector	Fischer Elektronik	ASLG40G
1	J2	AMP 640387-3	Header 3 pins	AMP	640387-3
1	J3	Power Jack	Power Jack type connector 2.5 mm	CUI Stack	PJ-002
1	J4	CON/3screws	3 screws PCB terminal, 5mm pin spacing	WAGO	237-133
3	J5, J7, J8	FASTON	Faston connector V90P vertical, 6.3mm wide	AMP	
2	L1, L2	1 mH	Inductor 1 mH, 0.2 A	Epcos	
8	Q101, Q102, Q103, Q104, Q105, Q106, Q107, Q401	MTD3302T4	Power N MOSFET Transistor, 30 V, 18 A	ON Semiconductor	MTD3302T4
1	R1	680R	Resistor 680 Ω , 5%, 0805	Vishay Dale	
1	R2	220k	Resistor 220 k Ω , 5%, 0805	Vishay Dale	
3	R3, R132, R133	100k	Resistor 100 k Ω , 5%, 0805	Vishay Dale	
1	R4	1.5k	Resistor 1.5k Ω , 5%, 0805	Vishay Dale	
1	R5	3.3k	Resistor 3.3k Ω , 5%, 0805	Vishay Dale	
3	R101, R102, R103	PMA-A-R030-1	Sensing resistor with Kelvin terminals, 30 m Ω , 1%	Isabellenhuette	PMA-A-R030-1
4	R104, R201, R208, R216	10k-1%	Resistor 10 k Ω , 1%, 0805	Vishay Dale	
4	R105, R203, R210, R217	2.7k-1%	Resistor 2.7 k Ω , 1%, 0805	Vishay Dale	
1	R106	120-1%	Resistor 120 Ω , 1%, 0805	Vishay Dale	
1	R107	180-1%	Resistor 180 Ω , 1%, 0805	Vishay Dale	
1	R108	1k8-1%	Resistor 1.8 k Ω , 1%, 0805	Vishay Dale	
1	R109	1k2-1%	Resistor 1.2 k Ω , 1%, 0805	Vishay Dale	

Schematics and Parts List

Table 4-1 Parts List (Sheet 3 of 4)

Qty.	Reference	Part Value	Description	Mfg.	Mfg. Part No.
18	R110, R111, R112, R113, R114, R115, R116, R117, R118, R204, R205, R211, R212, R218, R219, R222, R223, R401	10k	Resistor 10 k Ω , 5%, 0805	Vishay Dale	
12	R119, R120, R121, R122, R123, R124, R125, R126, R127, R128, R129, R130	51R	Resistor 51 Ω , 5%, 0805	Vishay Dale	
1	R131	10k/TRIMMER	Cermet-Trimmer 10 k Ω , 0.15W, 4315-SMD	Hinkel-elektronik	
3	R202, R209, R215	1M	Resistor 1 M Ω , 5%, 0805	Vishay Dale	
3	R206, R213, R220	5.6k	Resistor 5.6 k Ω , 5%, 0805	Vishay Dale	
3	R207, R214, R221	3k3-1%	Resistor 3.3 k Ω , 1%, 0805	Vishay Dale	
3	R224, R225, R226	33k	Resistor 33 k Ω , 5%, 0805	Vishay Dale	
6	R301, R304, R308, R311, R312, R315	39k-1%	Resistor 39 k Ω , 1%, 0805	Vishay Dale	
2	R302, R303, R309, R310, R313, R314	6k8-1%	Resistor 6.8 k Ω , 1%, 0805	Vishay Dale	
1	R305	390R	Resistor 390 Ω , 5%, 0805	Vishay Dale	
1	R306	100k-1%	Resistor 100 k Ω , 1%, 0805	Vishay Dale	
5	R307, R316, R317, R318, R319	33k-1%	Resistor 33 k Ω , 1%, 0805	Vishay Dale	
2	R402, R404	100R	Resistor 100 Ω , 5%, 0805	Vishay Dale	
1	R403	1R	Resistor 1 Ω , 1%, SQM type, 5-7W	Meggitt CGS	
1	SW1 (only in 140A01 board version)	Rotary Switch	Rotary Switch, RTE03 type, 3 positions	ITT Cannon	
1	SW1 (only in 140A02 board version)	pushbutton	Tactile SMD switch, B3S-1000 type, 6x6mm	OMRON	RS#183-701
1	U1	MC74HC14A	Hex Schmitt Inverter	ON Semiconductor	MC74HC14A
1	U2	MC78PC33NTR	Linear Voltage Regulator	ON Semiconductor	MC78PC33NTR

Table 4-1 Parts List (Sheet 4 of 4)

Qty.	Reference	Part Value	Description	Mfg.	Mfg. Part No.
1	U16	MC7805	Positive Voltage Regulator, 5V, 1A	ON Semiconductor	MC7805ACT
1	U103	MC33395	3-phase Gate Driver	Motorola	MC33395T
1	U104	DM74ALS1034M	Hex Non-Inverting Driver	Fairchild	DM74ALS1034M
1	U201	LM339D	Quad Comparator	ON Semiconductor	LM339D
2	U301, U302	MC33502D	Operational Amplifier, rail-to-rail	ON Semiconductor	MC33502D
1	U303	LM285M	Adjustable Voltage Reference	ON Semiconductor	LM285M
1	U401	MC33152D	High-Speed Dual MOSFET Driver	ON Semiconductor	MC33152D

Freescale Semiconductor, Inc.

Section 5. Design Considerations

5.1 Contents

5.2	Overview.....	37
5.3	3-Phase H-Bridge	37
5.4	Bus Voltage and Current Feedback Signals.....	38
5.5	Back-EMF Signals	40
5.6	Brake Control	41

5.2 Overview

From a systems point of view, the SMOS EVM motor board kit fits into an architecture that is designed for application development. In addition to the hardware that is needed to run a motor, a variety of feedback signals that facilitate control algorithm development are provided.

The SMOS EVM motor board's power output stage is a complementary MOS field effect transistor (MOSFET) 3-phase bridge that is capable of supplying and sensing 8 amps of continuous current. Feedback signals include bus voltage, phase currents, reconstructed bus current, Back-EMF (electromotive force), and zero crossing. The following sections describe these features.

5.3 3-Phase H-Bridge

Use of the Motorola integrated 3-phase gate driver, MC33395, considerably simplifies control of the output stage which is configured as a 3-phase H-bridge with six complementary N-MOSFET output transistors. Together with external components this device provides

reverse battery protection, a high-side, MOSFET switch, PWM frequencies up to 28 kHz and built-in protective circuitry to prevent damage to the MOSFET bridge and the drive's IC, and includes: thermal (not used), over-current, over-voltage (>27V) and under-voltage (<4V) shutdown. A schematic is shown in [Figure 4-2](#).

At the input, pulldown resistors R110 thru R118 set logic low in the absence of a signal. Open input pulldown is important, since it is desirable to keep the power transistors off in case of either a broken connection or absence of power on the control board. In order to accept 5-volt MCUs and 3.3-volt DSPs, a Fairchild non-inverting driver DM74ALS1034M unifies the level of the LSEx and HSEx input signals. This component has a minimum high-state logic 1 input voltage of 2.0 volts, and a maximum low-state logic 0 input voltage of 0.8 volts. The SMOS EVM motor board will thus enable the connection of large number of controller boards with various MCUs or DSPs, for example MC68HC908, HCS12, MPC555, DSP56F8XX(E), etc. Under-voltage lockout is not included in the gate drive. If this feature is desired, the control board's under-voltage detection comparator can be set for 0.85 volts.

5.4 Bus Voltage and Current Feedback Signals

Feedback signals proportional to bus voltage, phase currents and reconstructed bus current are provided in this section.

Bus voltage is scaled down by a voltage divider consisting of R104, R105, R106, R107, R108, and R19. The values are chosen such that a 16-volt maximum bus voltage corresponds to a 3.3-volt maximum analog-to-digital (A/D) input. [Figure 5-1](#) depicts the dc bus voltage circuitry. Phase currents are sampled by resistors R101, R102 and R103 in [Figure 4-2](#) and amplified by the circuit in [Figure 5-1](#), which shows the circuitry for phase A. This circuit provides a voltage output suitable for sampling with A/D inputs. An MC33502 is used as a differential amplifier. The gain is given by:

$$A = R301/R302$$

The output voltage is shifted up by 1.65 V into the middle of the converter range, to accommodate both positive and negative current swings. A ± 300 -mV voltage drop across the shunt resistor corresponds to a measured current range of ± 10 amps (peak value), again with 3.3V maximum on the output.

The SMOS EVM motor board measures and limits current according to a reconstructed bus current value that inverts swings of phase current signals and also shifts the output up by 1.65V with gain A=1. Its significance is adjustable with a trimmer, R131, used for setting an over-current comparator implemented in the SMOS driver. This comparator disables the driver outputs when the IS- (the driver pin) voltage rises above IS+, see Figure 5-2. This happens when the following is true:

$$IS- \geq IS+ \quad \cong \quad V_{IS+off} \approx 0.08 * I_{maxDCB} + 1.65 \quad [V; A]$$

CAUTION: The value, $V_{IS+} > 2.45V$, disables the over-current circuit protection functionality since the value on the V_{IS-} pin is always smaller than 2.45 volts. Allowing a larger V_{IS+} value can lead to permanent damage of the board if a current higher than 18 amps is applied!

For resetting board faults see step 6 in chapter 1.5.

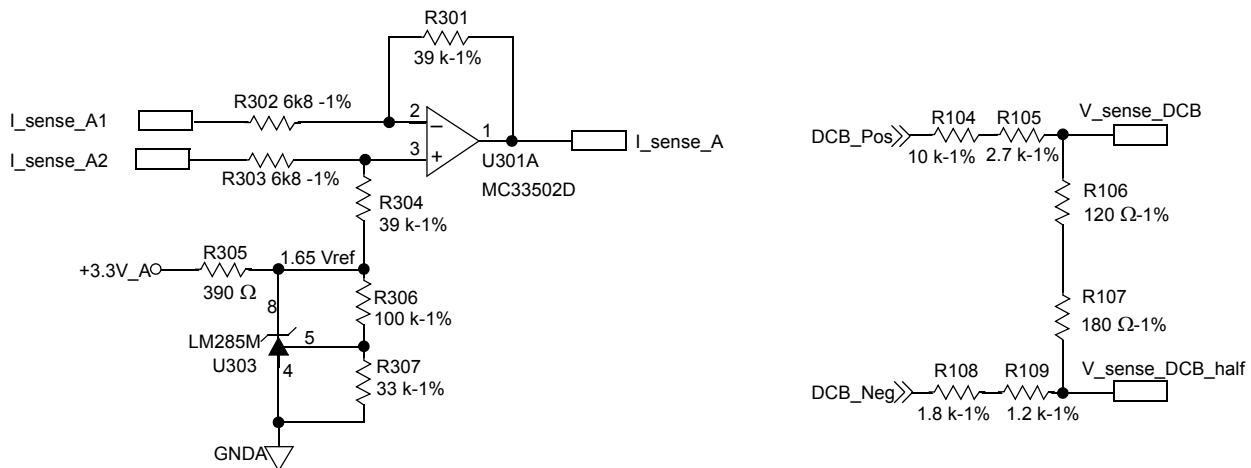

Figure 5-1 Phase Current and DC Bus Voltage Sensing

Design Considerations

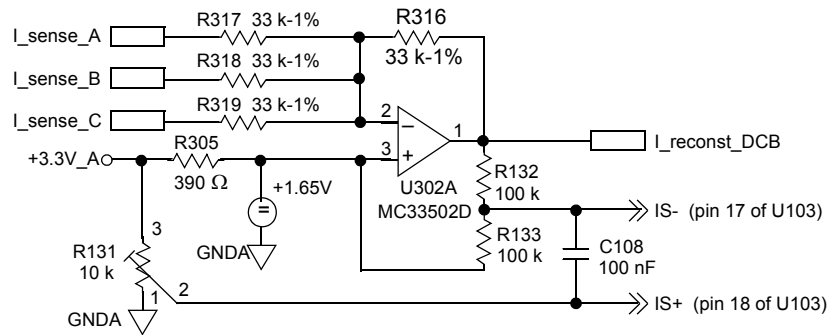

Figure 5-2 Reconstructed Bus Current

5.5 Back-EMF Signals

Back-EMF and zero crossing signals are included to support sensorless algorithms for brushless dc motors. Referring to [Figure 5-3](#), which shows the circuitry for phase C, the raw phase voltage is scaled down by a voltage divider consisting of R216, R217, and R221. One output from this divider, BEMF_sense_C produces Back-EMF sense voltage. Resistor values are chosen such that a 16-volt maximum phase voltage corresponds to a 3.3-volt maximum A/D input.

A zero crossing signal is obtained by comparing the motor phase voltage with ½ the value of the motor bus voltage. Comparator U201A performs this function, producing a zero crossing signal, Zero_cross_C.

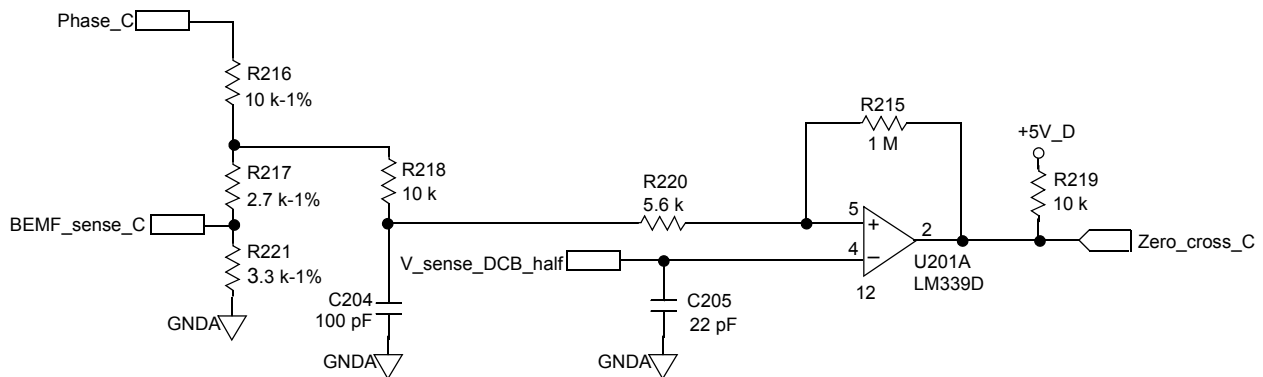

Figure 5-3 Phase C Back-EMF Feedback

5.6 Brake Control

A brake circuit is included to dissipate re-generative motor energy during periods of active deceleration or rapid reversal. Under these conditions, motor Back-EMF adds to the dc bus voltage. Without a means to dissipate excess energy, an over-voltage condition could easily occur.

The circuit shown in **Figure 4-5** connects R403 across the dc bus to dissipate energy. The transistor Q401 is turned on by software when the bus voltage sensing circuit in **Figure 5-1** indicates that the bus voltage could exceed safe levels. On-board power resistor R403 will safely dissipate up to 5 watts continuously or up to 50 watts for 5 seconds.

Freescale Semiconductor, Inc.

HOW TO REACH US:

USA/EUROPE/LOCATIONS NOT LISTED:

Motorola Literature Distribution
P.O. Box 5405
Denver, Colorado 80217
1-800-521-6274 or 480-768-2130

JAPAN:

Motorola Japan Ltd.
SPS, Technical Information Center
3-20-1, Minami-Azabu, Minato-ku
Tokyo 106-8573, Japan
81-3-3440-3569

ASIA/PACIFIC:

Motorola Semiconductors H.K. Ltd.
Silicon Harbour Centre
2 Dai King Street
Tai Po Industrial Estate
Tai Po, N.T., Hong Kong
852-26668334

HOME PAGE:

<http://motorola.com/semiconductors>



Information in this document is provided solely to enable system and software implementers to use Motorola products. There are no express or implied copyright licenses granted hereunder to design or fabricate any integrated circuits or integrated circuits based on the information in this document.

Motorola reserves the right to make changes without further notice to any products herein. Motorola makes no warranty, representation or guarantee regarding the suitability of its products for any particular purpose, nor does Motorola assume any liability arising out of the application or use of any product or circuit, and specifically disclaims any and all liability, including without limitation consequential or incidental damages. "Typical" parameters that may be provided in Motorola data sheets and/or specifications can and do vary in different applications and actual performance may vary over time. All operating parameters, including "Typicals", must be validated for each customer application by customer's technical experts. Motorola does not convey any license under its patent rights nor the rights of others. Motorola products are not designed, intended, or authorized for use as components in systems intended for surgical implant into the body, or other applications intended to support or sustain life, or for any other application in which the failure of the Motorola product could create a situation where personal injury or death may occur. Should Buyer purchase or use Motorola products for any such unintended or unauthorized application, Buyer shall indemnify and hold Motorola and its officers, employees, subsidiaries, affiliates, and distributors harmless against all claims, costs, damages, and expenses, and reasonable attorney fees arising out of, directly or indirectly, any claim of personal injury or death associated with such unintended or unauthorized use, even if such claim alleges that Motorola was negligent regarding the design or manufacture of the part.

MOTOROLA and the Stylized M Logo are registered in the US Patent and Trademark Office. All other product or service names are the property of their respective owners. Motorola, Inc. is an Equal Opportunity/Affirmative Action Employer.

© Motorola Inc. 2003

DRM33395/D
Rev. 2
05/2003

**For More Information On This Product,
Go to: www.freescale.com**