HB56HW465DB-A Series

4196304-word × 64-bit High Density Dynamic RAM Module

HITACHI

ADE-203-829A (Z)

Rev. 1.0

Sep. 19, 1997

Description

The HB56HW465DB-A Series is a 4 M× 64 Dynamic RAM Small Outline Dual In-line Memory Module (S. O. DIMM), mounted 4 pieces of 64-Mbit DRAM (HM5165165A/AL) sealed in TSOP package and 1 piece of serial EEPROM (24C02) for Presence Detect (PD). The HB56HW465DB-A Series offers Extended Data Out (EDO) Page Mode as a high speed access mode. An outline of the HB56HW465DB-A Series is 144-pin Zig Zag Dual tabs socket type compact and thin package. Therefore, the HB56HW465DB-A Series makes high density mounting possible without surface mount technology. The HB56HW465DB-A Series provides common data inputs and outputs. Decoupling capacitors are mounted beside each TSOP on the module board.

Features

- 144-pin Zig Zag Dual tabs socket type
 - Outline: 67.60 mm (Length) × 25.40 mm (Height) × 3.80 mm (Thickness)
 - Lead pitch : 0.80 mm
- Single 3.3 V (±0.3 V)
- High speed
 - Access time: $t_{RAC} = 60 \text{ ns}/70 \text{ ns}$ (max)
 - Access time: $t_{CAC} = 15 \text{ ns}/18 \text{ ns}$ (max)
- Low power dissipation
 - Active mode: 2.60 W/2.24 W (max)
 - Standby mode (TTL): 28.8 mW (max)
 - Standby mode (CMOS): 14.4 mW (max)
4.3 mW (max) (L-version)
- JEDEC standard outline S. O. DIMM
- EDO page mode capability
- 4096 refresh cycles: 64 ms
: 128 ms (L-version)

HB56HW465DB-A Series

- 4 variations of refresh
 - $\overline{\text{RAS}}$ -only refresh
 - $\overline{\text{CAS}}$ -before- $\overline{\text{RAS}}$ refresh
 - Hidden refresh
 - Self refresh (L-version)

Ordering Information

Type No.	Access time	Package	Contact pad
HB56HW465DB-6A	60 ns	144-pin small outline DIMM	Gold
HB56HW465DB-7A	70 ns		
HB56HW465DB-6AL	60 ns		
HB56HW465DB-7AL	70 ns		

Pin Arrangement

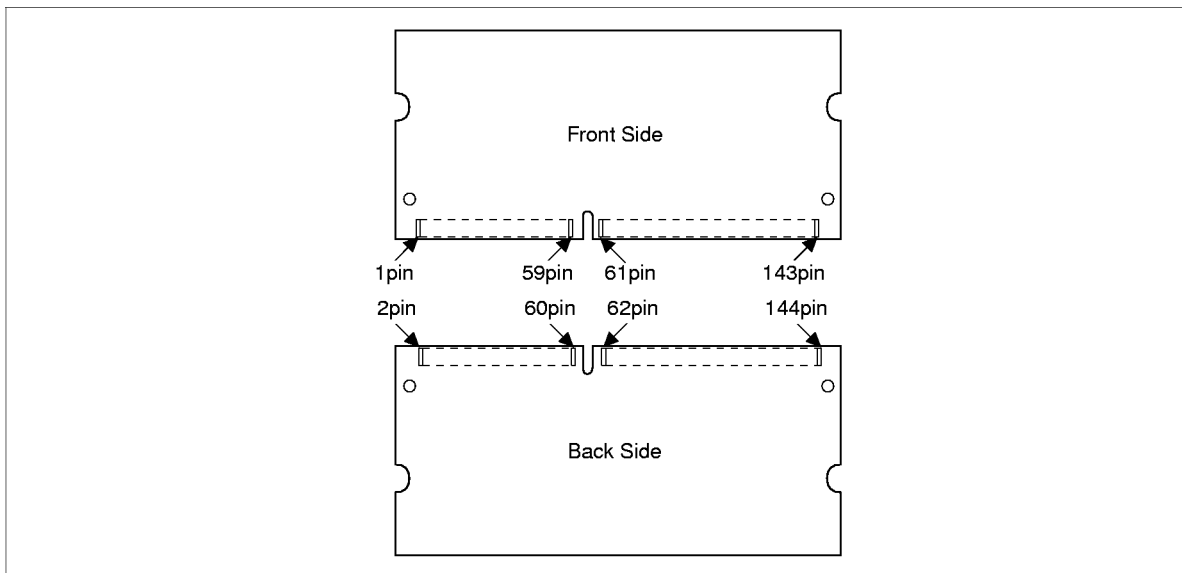

Front side		Back side					
Pin No.	Signal name	Pin No.	Signal name	Pin No.	Signal name	Pin No.	Signal name
1	V_{SS}	73	$\overline{\text{OE}}$	2	V_{SS}	74	NC
3	DQ0	75	V_{SS}	4	DQ32	76	V_{SS}
5	DQ1	77	NC	6	DQ33	78	NC
7	DQ2	79	NC	8	DQ34	80	NC
9	DQ3	81	V_{CC}	10	DQ35	82	V_{CC}
11	V_{CC}	83	DQ16	12	V_{CC}	84	DQ48

HB56HW465DB-A Series

Front side		Back side					
Pin No.	Signal name	Pin No.	Signal name	Pin No.	Signal name	Pin No.	Signal name
13	DQ4	85	DQ17	14	DQ36	86	DQ49
15	DQ5	87	DQ18	16	DQ37	88	DQ50
17	DQ6	89	DQ19	18	DQ38	90	DQ51
19	DQ7	91	V _{SS}	20	DQ39	92	V _{SS}
21	V _{SS}	93	DQ20	22	V _{SS}	94	DQ52
23	$\overline{CE0}$	95	DQ21	24	$\overline{CE4}$	96	DQ53
25	$\overline{CE1}$	97	DQ22	26	$\overline{CE5}$	98	DQ54
27	V _{CC}	99	DQ23	28	V _{CC}	100	DQ55
29	A0	101	V _{CC}	30	A3	102	V _{CC}
31	A1	103	A6	32	A4	104	A7
33	A2	105	A8	34	A5	106	A11
35	V _{SS}	107	V _{SS}	36	V _{SS}	108	V _{SS}
37	DQ8	109	A9	38	DQ40	110	NC
39	DQ9	111	A10	40	DQ41	112	NC
41	DQ10	113	V _{CC}	42	DQ42	114	V _{CC}
43	DQ11	115	$\overline{CE2}$	44	DQ43	116	$\overline{CE6}$
45	V _{CC}	117	$\overline{CE3}$	46	V _{CC}	118	$\overline{CE7}$
47	DQ12	119	V _{SS}	48	DQ44	120	V _{SS}
49	DQ13	121	DQ24	50	DQ45	122	DQ56
51	DQ14	123	DQ25	52	DQ46	124	DQ57
53	DQ15	125	DQ26	54	DQ47	126	DQ58
55	V _{SS}	127	DQ27	56	V _{SS}	128	DQ59
57	NC	129	V _{CC}	58	NC	130	V _{CC}
59	NC	131	DQ28	60	NC	132	DQ60
61	NC	133	DQ29	62	NC	134	DQ61
63	V _{CC}	135	DQ30	64	V _{CC}	136	DQ62
65	NC	137	DQ31	66	NC	138	DQ63
67	\overline{WE}	139	V _{SS}	68	NC	140	V _{SS}
69	$\overline{RE0}$	141	SDA	70	NC	142	SCL
71	NC	143	V _{CC}	72	NC	144	V _{CC}

HB56HW465DB-A Series

Pin Description

Pin name	Function
A0 to A11	Address input <ul style="list-style-type: none">• Row address A0 to A11• Column address A0 to A9• Refresh address A0 to A11
DQ0 to DQ63	Data input/output
$\overline{RE}0$	Row address strobe (\overline{RAS})
$\overline{CE}0$ to $\overline{CE}7$	Column address strobe (\overline{CAS})
\overline{WE}	Read/Write enable
\overline{OE}	Output enable
SDA	Serial data for PD
SCL	Serial clock for PD
V_{cc}	Power supply
V_{ss}	Ground
NC	No connection

HB56HW465DB-A Series

Serial PD Matrix*¹

Byte No.	Function described	Bit7	Bit6	Bit5	Bit4	Bit3	Bit2	Bit1	Bit0	Hex value	Comments
0	Number of bytes used by module manufacturer	1	0	0	0	0	0	0	0	80	128
1	Total SPD memory size	0	0	0	0	1	0	0	0	08	256 byte
2	Memory type	0	0	0	0	0	0	1	0	02	EDO
3	Number of row addresses bits	0	0	0	0	1	1	0	0	0C	12
4	Number of column addresses bits	0	0	0	0	1	0	1	0	0A	10
5	Number of banks	0	0	0	0	0	0	0	1	01	1
6	Module data width	0	1	0	0	0	0	0	0	40	64 bits
7	Module data width (continued)	0	0	0	0	0	0	0	0	00	0 (+)
8	Module interface signal levels	0	0	0	0	0	0	0	1	01	LVTTTL
9	$\overline{\text{RAS}}$ access time -6A/-6AL	0	0	1	1	1	1	0	0	3C	$t_{\text{RAC}} = 60 \text{ ns}$
	$\overline{\text{RAS}}$ access time -7A/-7AL	0	1	0	0	0	1	1	0	46	$t_{\text{RAC}} = 70 \text{ ns}$
10	$\overline{\text{CAS}}$ access time -6A/-6AL	0	0	0	0	1	1	1	1	0F	$t_{\text{CAC}} = 15 \text{ ns}$
	$\overline{\text{CAS}}$ access time -7A/-7AL	0	0	0	1	0	0	1	0	12	$t_{\text{CAC}} = 18 \text{ ns}$
11	Module configuration type	0	0	0	0	0	0	0	0	00	Non parity
12	Refresh rate/type -6A/-7A	0	0	0	0	0	0	0	0	00	Normal (15.625 μs)
	Refresh rate/type -6AL/-7AL (L-version)	1	0	0	0	0	0	1	1	83	Self refresh (31.3 μs)
13	DRAM width	0	0	0	1	0	0	0	0	10	4M \times 16
14	Error checking DRAM data width	0	0	0	0	0	0	0	0	00	
15 to 31	Reserved for future offerings	0	0	0	0	0	0	0	0	00	
32 to 61	Superset information	0	0	0	0	0	0	0	0	00	Future offerings
62	SPD revision	0	0	0	0	0	0	0	1	01	Rev. 1
63	Checksum for bytes 0 to 62 -6A	0	0	1	1	1	1	1	0	3E	
	Checksum for bytes 0 to 62 -7A	0	1	0	0	1	0	1	1	4B	
	Checksum for bytes 0 to 62 -6AL	1	1	0	0	0	0	0	1	C1	
	Checksum for bytes 0 to 62 -7AL	1	1	0	0	1	1	1	0	CE	

HB56HW465DB-A Series

Serial PD Matrix*¹ (cont)

Byte No.	Function described	Bit7	Bit6	Bit5	Bit4	Bit3	Bit2	Bit1	Bit0	Hex value	Comments
64	Manufacturer's JEDEC ID code	0	0	0	0	0	1	1	1	07	Hitachi
65 to 71	Manufacturer's JEDEC ID code	0	0	0	0	0	0	0	0	00	
72	Manufacturing location	×	×	×	×	×	×	×	×	×	* ² (ASCII-8bit code)
73	Manufacturer's part number	0	1	0	0	1	0	0	0	48	H
74	Manufacturer's part number	0	1	0	0	0	0	1	0	42	B
75	Manufacturer's part number	0	0	1	1	0	1	0	1	35	5
76	Manufacturer's part number	0	0	1	1	0	1	1	0	36	6
77	Manufacturer's part number	0	1	0	0	1	0	0	0	48	H
78	Manufacturer's part number	0	1	0	1	0	1	1	1	57	W
79	Manufacturer's part number	0	0	1	1	0	1	0	0	34	4
80	Manufacturer's part number	0	0	1	1	0	1	1	0	36	6
81	Manufacturer's part number	0	0	1	1	0	1	0	1	35	5
82	Manufacturer's part number	0	1	0	0	0	1	0	0	44	D
83	Manufacturer's part number	0	1	0	0	0	0	1	0	42	B
84	Manufacturer's part number	0	1	0	1	1	1	1	1	5F	—
85	Manufacturer's part number -6A/-6AL	0	0	1	1	0	1	1	0	36	6
	Manufacturer's part number -7A/-7AL	0	0	1	1	0	1	1	1	37	7
86	Manufacturer's part number	0	1	0	0	0	0	0	1	41	A
87	Manufacturer's part number -6A/-7A	0	0	1	0	0	0	0	0	20	(Space)
	Manufacturer's part number -6AL/-7AL (L-version)	0	1	0	0	1	1	0	0	4C	L
88 to 90	Manufacturer's part number	0	0	1	0	0	0	0	0	20	(Space)
91	Revision code	0	0	1	1	0	0	0	0	30	Initial
92	Revision code	0	0	1	0	0	0	0	0	20	(Space)
93	Manufacturing date (year code)	×	×	×	×	×	×	×	×	×	Year code* ³ (binary)
94	Manufacturing date (week code)	×	×	×	×	×	×	×	×	×	Week code* ⁴ (binary)

HB56HW465DB-A Series

Serial PD Matrix*¹ (cont)

Byte No.	Function described	Bit7	Bit6	Bit5	Bit4	Bit3	Bit2	Bit1	Bit0	Hex value	Comments
95 to 98	Assembly serial number	* ⁵									
99 to 125	Manufacturer specific data	* ⁶									
126	Reserved	0	0	0	0	0	0	0	0	00	
127	Reserved	0	0	0	0	0	0	0	0	00	

- Notes:
1. All serial PD data are not protected. 0: Serial data, "driven Low", 1: Serial data, "driven High"
 2. Byte 72 is manufacturing location code. (ex: in case of Japan, byte 72 is 4Ah. 4Ah shows "J" on ASCII code.)
 3. Byte 93 (Manufacturing date-year code) ex: 61h shows year '97. 62h shows year '98.
 4. Byte 94 (Manufacturing date-week code) ex: 0Bh shows week 11. 24h shows week 36.
 5. Byte 95 through 98 are assembly serial number.
 6. All bits of byte 99 through 125 are not defined ("1" or "0").

HB56HW465DB-A Series

Block Diagram

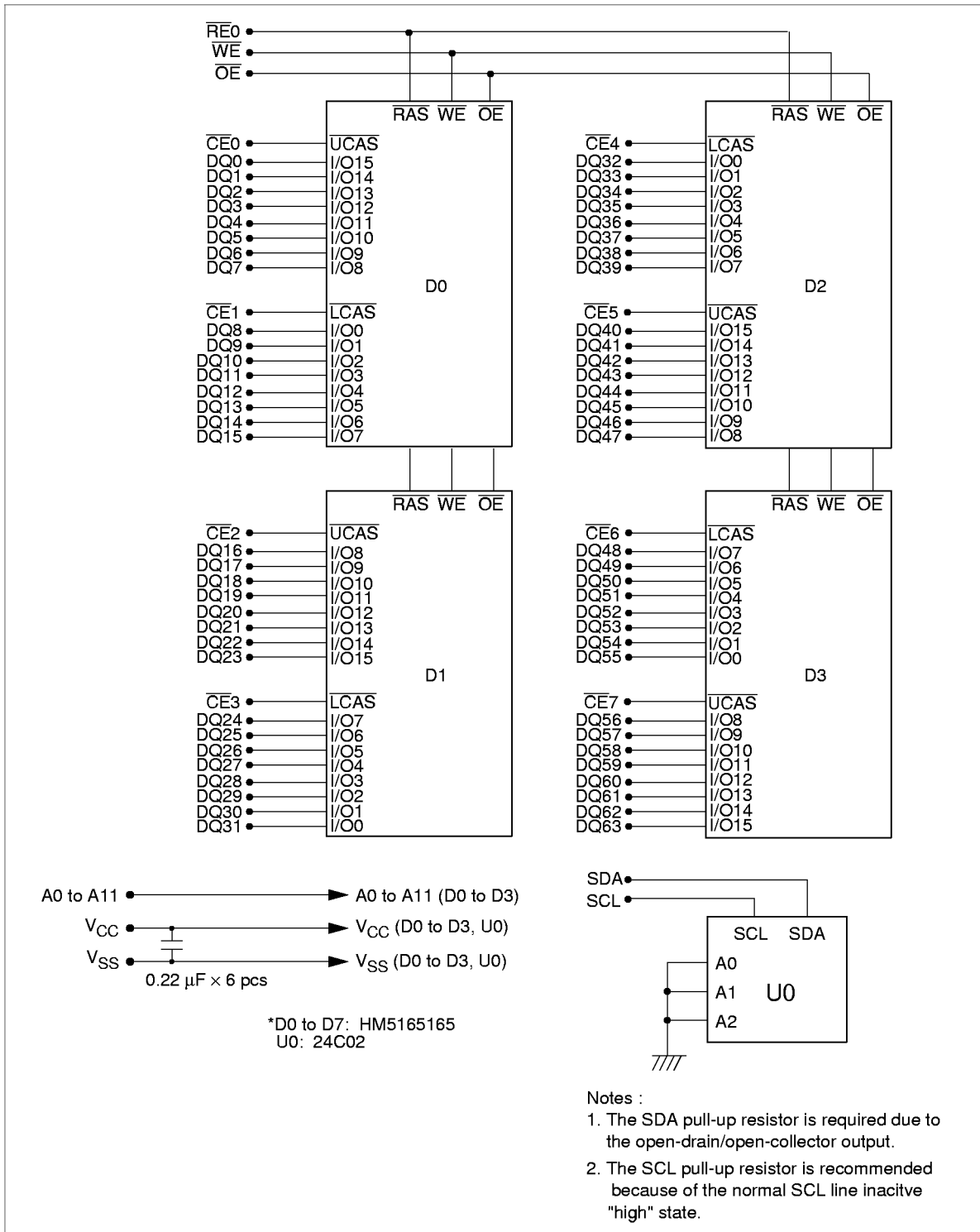

HB56HW465DB-A Series

Absolute Maximum Ratings

Parameter	Symbol	Value	Unit
Voltage on any pin relative to V_{SS}	V_T	-0.5 to +4.6	V
Supply voltage relative to V_{SS}	V_{CC}	-0.5 to +4.6	V
Short circuit output current	I_{out}	50	mA
Power dissipation	P_T	4.0	W
Operating temperature	T_{opr}	0 to +70	°C
Storage temperature	T_{stg}	-55 to +125	°C

Recommended DC Operating Conditions ($T_a = 0$ to +70°C)

Parameter	Symbol	Min	Typ	Max	Unit	Notes
Supply voltage	V_{CC}	3.0	3.3	3.6	V	1, 2
Input high voltage	V_{IH}	2.0	—	$V_{CC} + 0.3$	V	1
Input low voltage	V_{IL}	-0.3	—	0.8	V	1

Notes: 1. All voltage referred to V_{SS} .

2. The supply voltage with all V_{CC} pins must be on the same level. The supply voltage with all V_{SS} pins must be on the same level.

HB56HW465DB-A Series

DC Characteristics (Ta = 0 to +70°C, V_{CC} = 3.3 V ± 0.3 V, V_{SS} = 0 V)

Parameter	Symbol	HB56HW465DB-A				Unit	Test conditions
		60 ns		70 ns			
		Min	Max	Min	Max		
Operating current* ¹ , * ²	I _{CC1}	—	720	—	620	mA	t _{RC} = min
Standby current	I _{CC2}	—	8	—	8	mA	TTL interface RAS, CAS = V _{IH} Dout = High-Z
		—	4	—	4	mA	CMOS interface RAS, CAS ≥ V _{CC} - 0.2 V Dout = High-Z
Standby current (L-version)	I _{CC2}	—	1.2	—	1.2	mA	CMOS interface RAS, CAS ≥ V _{CC} - 0.2 V Dout = High-Z
RAS-only refresh current* ²	I _{CC3}	—	720	—	620	mA	t _{RC} = min
Standby current* ¹	I _{CC5}	—	20	—	20	mA	RAS = V _{IH} , CAS = V _{IL} Dout = enable
CAS-before-RAS refresh current	I _{CC6}	—	560	—	480	mA	t _{RC} = min
EDO page mode current* ¹ , * ³	I _{CC7}	—	600	—	540	mA	t _{HPC} = min
Battery backup current* ⁴ (Standby with CBR refresh) (L-version)	I _{CC10}	—	2.6	—	2.6	mA	CMOS interface Dout = High-Z CBR refresh: t _{RC} = 31.3 μs t _{RAS} ≤ 0.3 μs
Self refresh mode current (L-version)	I _{CC11}	—	2	—	2	mA	CMOS interface RAS, CAS ≤ 0.2 V Dout = High-Z
Input leakage current	I _{LI}	-10	10	-10	10	μA	0 V ≤ Vin ≤ V _{CC} + 0.3 V
Output leakage current	I _{LO}	-10	10	-10	10	μA	0 V ≤ Vout ≤ V _{CC} Dout = disable
Output high voltage	V _{OH}	2.4	V _{CC}	2.4	V _{CC}	V	High Iout = -2 mA
Output low voltage	V _{OL}	0	0.4	0	0.4	V	Low Iout = 2 mA

Notes : 1. I_{CC} depends on output load condition when the device is selected. I_{CC} max is specified at the output open condition.

2. Address can be changed once or less while RAS = V_{IL}.

3. Address can be changed once or less within one page mode cycle t_{HPC}.

4. V_{IH} ≥ V_{CC} - 0.2 V, 0 V ≤ V_{IL} ≤ 0.2 V.

HB56HW465DB-A Series

Capacitance ($T_a = 25^\circ\text{C}$, $V_{CC} = 3.3 \text{ V} \pm 0.3 \text{ V}$)

Parameter	Symbol	Typ	Max	Unit	Notes
Input capacitance (Address)	C_{i1}	—	40	pF	1
Input capacitance ($\overline{\text{RAS}}$, $\overline{\text{WE}}$, $\overline{\text{OE}}$)	C_{i2}	—	48	pF	1
Input capacitance ($\overline{\text{CAS}}$)	C_{i3}	—	22	pF	1
I/O capacitance (DQ)	$C_{i/O}$	—	17	pF	1, 2

- Notes : 1. Capacitance measured with Boonton Meter or effective capacitance measuring method.
2. $\overline{\text{CAS}} = V_{IH}$ to disable Dout.

HB56HW465DB-A Series

AC Characteristics ($T_a = 0$ to $+70^\circ\text{C}$, $V_{CC} = 3.3\text{ V} \pm 0.3\text{ V}$, $V_{SS} = 0\text{ V}$) *¹, *², *¹⁸

Test Conditions

- Input rise and fall time: 2 ns
- Input levels: $V_{IL} = 0\text{ V}$, $V_{IH} = 3\text{ V}$
- Input timing reference levels: 0.8 V, 2.0 V
- Output timing reference levels: 0.8 V, 2.0 V
- Output load: 1 TTL gate + C_L (100 pF) (Including scope and jig)

Read, Write, Read-Modify-Write and Refresh Cycles (Common parameters)

Parameter	Symbol	HB56HW465DB-A				Unit	Notes
		60 ns		70 ns			
		Min	Max	Min	Max		
Random read or write cycle time	t_{RC}	104	—	124	—	ns	
$\overline{\text{RAS}}$ precharge time	t_{RP}	40	—	50	—	ns	
$\overline{\text{CAS}}$ precharge time	t_{CP}	10	—	13	—	ns	
$\overline{\text{RAS}}$ pulse width	t_{RAS}	60	10000	70	10000	ns	
$\overline{\text{CAS}}$ pulse width	t_{CAS}	10	10000	13	10000	ns	
Row address setup time	t_{ASR}	0	—	0	—	ns	
Row address hold time	t_{RAH}	10	—	10	—	ns	
Column address setup time	t_{ASC}	0	—	0	—	ns	
Column address hold time	t_{CAH}	10	—	13	—	ns	
$\overline{\text{RAS}}$ to $\overline{\text{CAS}}$ delay time	t_{RCD}	20	45	20	52	ns	3
$\overline{\text{RAS}}$ to column address delay time	t_{RAD}	14	30	15	35	ns	4
$\overline{\text{RAS}}$ hold time	t_{RSH}	15	—	18	—	ns	
$\overline{\text{CAS}}$ hold time	t_{CSH}	48	—	58	—	ns	
$\overline{\text{CAS}}$ to $\overline{\text{RAS}}$ precharge time	t_{CRP}	5	—	5	—	ns	
$\overline{\text{OE}}$ to D_{in} delay time	t_{OED}	15	—	18	—	ns	5
$\overline{\text{OE}}$ delay time from D_{in}	t_{DZO}	0	—	0	—	ns	6
$\overline{\text{CAS}}$ delay time from D_{in}	t_{DZC}	0	—	0	—	ns	6
Transition time (rise and fall)	t_T	2	50	2	50	ns	7

HB56HW465DB-A Series

Read Cycle

Parameter	Symbol	HB56HW465DB-A				Unit	Notes
		60 ns		70 ns			
		Min	Max	Min	Max		
Access time from $\overline{\text{RAS}}$	t_{RAC}	—	60	—	70	ns	8, 9
Access time from $\overline{\text{CAS}}$	t_{CAC}	—	15	—	18	ns	9, 10, 17
Access time from address	t_{AA}	—	30	—	35	ns	9, 11, 17
Access time from $\overline{\text{OE}}$	t_{OEA}	—	15	—	18	ns	9
Read command setup time	t_{RCS}	0	—	0	—	ns	
Read command hold time to $\overline{\text{CAS}}$	t_{RCH}	0	—	0	—	ns	12
Read command hold time from $\overline{\text{RAS}}$	t_{RCHR}	60	—	70	—	ns	
Read command hold time to $\overline{\text{RAS}}$	t_{RRH}	0	—	0	—	ns	12
Column address to $\overline{\text{RAS}}$ lead time	t_{RAL}	30	—	35	—	ns	
Column address to $\overline{\text{CAS}}$ lead time	t_{CAL}	18	—	23	—	ns	
$\overline{\text{CAS}}$ to output in low-Z	t_{CLZ}	0	—	0	—	ns	
Output data hold time	t_{OH}	3	—	3	—	ns	22
Output data hold time from $\overline{\text{OE}}$	t_{OHO}	3	—	3	—	ns	
Output buffer turn-off time	t_{OFF}	—	15	—	15	ns	13, 22
Output buffer turn-off to $\overline{\text{OE}}$	t_{OEZ}	—	15	—	15	ns	13
$\overline{\text{CAS}}$ to Din delay time	t_{CDD}	15	—	18	—	ns	5
Output data hold time from $\overline{\text{RAS}}$	t_{OHR}	3	—	3	—	ns	22
Output buffer turn-off to $\overline{\text{RAS}}$	t_{OFR}	—	15	—	15	ns	13, 22
Output buffer turn-off to $\overline{\text{WE}}$	t_{WEZ}	—	15	—	15	ns	13
$\overline{\text{WE}}$ to Din delay time	t_{WED}	15	—	18	—	ns	
$\overline{\text{RAS}}$ to Din delay time	t_{RDD}	15	—	18	—	ns	

HB56HW465DB-A Series

Write Cycle

Parameter	Symbol	HB56HW465DB-A				Unit	Notes
		60 ns		70 ns			
		Min	Max	Min	Max		
Write command setup time	t_{WCS}	0	—	0	—	ns	14
Write command hold time	t_{WCH}	10	—	13	—	ns	
Write command pulse width	t_{WCP}	10	—	10	—	ns	
Write command to \overline{RAS} lead time	t_{RWL}	15	—	18	—	ns	
Write command to \overline{CAS} lead time	t_{CWL}	10	—	13	—	ns	
Data-in setup time	t_{DS}	0	—	0	—	ns	15
Data-in hold time	t_{DH}	10	—	13	—	ns	15

Read-Modify-Write Cycle

Parameter	Symbol	HB56HW465DB-A				Unit	Notes
		60 ns		70 ns			
		Min	Max	Min	Max		
Read-modify-write cycle time	t_{RWC}	149	—	175	—	ns	
\overline{RAS} to \overline{WE} delay time	t_{RWD}	78	—	91	—	ns	14
\overline{CAS} to \overline{WE} delay time	t_{CWD}	33	—	39	—	ns	14
Column address to \overline{WE} delay time	t_{AWD}	48	—	56	—	ns	14
\overline{OE} hold time from \overline{WE}	t_{OEH}	15	—	18	—	ns	

Refresh Cycle

Parameter	Symbol	HB56HW465DB-A				Unit	Notes
		60 ns		70 ns			
		Min	Max	Min	Max		
\overline{CAS} setup time (CBR refresh cycle)	t_{CSR}	5	—	5	—	ns	
\overline{CAS} hold time (CBR refresh cycle)	t_{CHR}	10	—	10	—	ns	
\overline{WE} setup time (CBR refresh cycle)	t_{WRP}	0	—	0	—	ns	
\overline{WE} hold time (CBR refresh cycle)	t_{WRH}	10	—	10	—	ns	
\overline{RAS} precharge to \overline{CAS} hold time	t_{RPC}	0	—	0	—	ns	

HB56HW465DB-A Series

EDO Page Mode Cycle

Parameter	Symbol	HB56HW465DB-A				Unit	Notes
		60 ns		70 ns			
		Min	Max	Min	Max		
EDO page mode cycle time	t_{HPC}	25	—	30	—	ns	20
EDO page mode \overline{RAS} pulse width	t_{RASP}	—	100000	—	100000	ns	16
Access time from \overline{CAS} precharge	t_{CPA}	—	35	—	40	ns	9, 17
\overline{RAS} hold time from \overline{CAS} precharge	t_{CPRH}	35	—	40	—	ns	
Output data hold time from \overline{CAS} low	t_{DOH}	3	—	3	—	ns	9
\overline{CAS} hold time referred \overline{OE}	t_{COL}	10	—	13	—	ns	
\overline{CAS} to \overline{OE} setup time	t_{COP}	10	—	10	—	ns	
Read command hold time from \overline{CAS} precharge	t_{RCHC}	35	—	40	—	ns	
Write pulse width during \overline{CAS} precharge	t_{WPE}	10	—	10	—	ns	
\overline{OE} precharge time	t_{OEP}	10	—	10	—	ns	

EDO Page Mode Read-Modify-Write Cycle

Parameter	Symbol	HB56HW465DB-A				Unit	Notes
		60 ns		70 ns			
		Min	Max	Min	Max		
EDO page mode read- modify-write cycle time	t_{HPRWC}	68	—	79	—	ns	
\overline{WE} delay time from \overline{CAS} precharge	t_{CPW}	54	—	62	—	ns	14

Refresh

Parameter	Symbol	Max	Unit	Notes
Refresh period	t_{REF}	64	ms	4096 cycles
Refresh period (L-version)	t_{REF}	128	ms	4096 cycles

HB56HW465DB-A Series

Self Refresh Mode (L-version)

Parameter	Symbol	HB56HW465DB-A				Unit	Notes
		60 ns		70 ns			
		Min	Max	Min	Max		
$\overline{\text{RAS}}$ pulse width (self refresh)	t_{RASS}	100	—	100	—	μs	23
$\overline{\text{RAS}}$ precharge time (self refresh)	t_{RPS}	110	—	130	—	ns	23
$\overline{\text{CAS}}$ hold time (self refresh)	t_{CHS}	-50	—	-50	—	ns	

- Notes:
1. AC measurements assume $t_T = 2 \text{ ns}$.
 2. An initial pause of 200 μs is required after power up followed by a minimum of eight initialization cycles (any combination of cycles containing $\overline{\text{RAS}}$ -only refresh or $\overline{\text{CAS}}$ -before- $\overline{\text{RAS}}$ refresh).
 3. Operation with the t_{RCD} (max) limit insures that t_{RAC} (max) can be met, t_{RCD} (max) is specified as a reference point only; if t_{RCD} is greater than the specified t_{RCD} (max) limit, then access time is controlled exclusively by t_{CAC} .
 4. Operation with the t_{RAD} (max) limit insures that t_{RAC} (max) can be met, t_{RAD} (max) is specified as a reference point only; if t_{RAD} is greater than the specified t_{RAD} (max) limit, then access time is controlled exclusively by t_{AA} .
 5. Either t_{OED} or t_{CDD} must be satisfied.
 6. Either t_{DZO} or t_{DZC} must be satisfied.
 7. V_{IH} (min) and V_{IL} (max) are reference levels for measuring timing of input signals. Also, transition times are measured between V_{IH} (min) and V_{IL} (max).
 8. Assumes that $t_{\text{RCD}} \leq t_{\text{RCD}}$ (max) and $t_{\text{RAD}} \leq t_{\text{RAD}}$ (max). If t_{RCD} or t_{RAD} is greater than the maximum recommended value shown in this table, t_{RAC} exceeds the value shown.
 9. Measured with a load circuit equivalent to 1 TTL loads and 100 pF.
 10. Assumes that $t_{\text{RCD}} \geq t_{\text{RCD}}$ (max) and $t_{\text{RCD}} + t_{\text{CAC}}$ (max) $\geq t_{\text{RAD}} + t_{\text{AA}}$ (max).
 11. Assumes that $t_{\text{RAD}} \geq t_{\text{RAD}}$ (max) and $t_{\text{RCD}} + t_{\text{CAC}}$ (max) $\leq t_{\text{RAD}} + t_{\text{AA}}$ (max).
 12. Either t_{RCH} or t_{RRH} must be satisfied for a read cycles.
 13. t_{OFF} (max), t_{OEZ} (max), t_{WEZ} (max) and t_{OFR} (max) define the time at which the outputs achieve the open circuit condition and are not referred to output voltage levels.
 14. t_{WCS} , t_{RWD} , t_{CWD} , t_{AWD} and t_{CPW} are not restrictive operating parameters. They are included in the data sheet as electrical characteristics only; if $t_{\text{WCS}} \geq t_{\text{WCS}}$ (min), the cycle is an early write cycle and the data out pin will remain open circuit (high impedance) throughout the entire cycle; if $t_{\text{RWD}} \geq t_{\text{RWD}}$ (min), $t_{\text{CWD}} \geq t_{\text{CWD}}$ (min), and $t_{\text{AWD}} \geq t_{\text{AWD}}$ (min), or $t_{\text{CWD}} \geq t_{\text{CWD}}$ (min), $t_{\text{AWD}} \geq t_{\text{AWD}}$ (min) and $t_{\text{CPW}} \geq t_{\text{CPW}}$ (min), the cycle is a read-modify-write and the data output will contain data read from the selected cell; if neither of the above sets of conditions is satisfied, the condition of the data out (at access time) is indeterminate.
 15. These parameters are referred to $\overline{\text{CAS}}$ leading edge in early write cycles and to $\overline{\text{WE}}$ leading edge in delayed write or read-modify-write cycles.
 16. t_{RASp} defines $\overline{\text{RAS}}$ pulse width in EDO page mode cycles.
 17. Access time is determined by the longest among t_{AA} , t_{CAC} and t_{CPA} .
 18. All the V_{CC} and V_{SS} pins shall be supplied with the same voltages.
 19. In delayed write or read-modify-write cycles, $\overline{\text{OE}}$ must disable output buffer prior to applying data to the device.

20. t_{HPC} (min) can be achieved during a series of EDO page mode write cycles or EDO page mode read cycles. If both write and read operation are mixed in a EDO page mode $\overline{\text{RAS}}$ cycle (EDO page mode mix cycle (1), (2)), minimum value of $\overline{\text{CAS}}$ cycle ($t_{\text{CAS}} + t_{\text{CP}} + 2 t_{\text{T}}$) becomes greater than the specified t_{HPC} (min) value. The value of $\overline{\text{CAS}}$ cycle time of mixed EDO page mode is shown in EDO page mode mix cycle (1) and (2).
21. When output buffers are enabled once, sustain the low impedance state until valid data is obtained. When output buffer is turned on and off within a very short time, generally it causes large $V_{\text{CC}}/V_{\text{SS}}$ line noise, which causes to degrade $V_{\text{IH min}}/V_{\text{IL max}}$ level.
22. Data output turns off and becomes high impedance from later rising edge of $\overline{\text{RAS}}$ and $\overline{\text{CAS}}$. Hold time and turn off time are specified by the timing specifications of later rising edge of $\overline{\text{RAS}}$ and $\overline{\text{CAS}}$ between t_{OHR} and t_{OH} , and between t_{OFR} and t_{OFF} .
23. Please do not use t_{RASS} timing, $10 \mu\text{s} \leq t_{\text{RASS}} \leq 100 \mu\text{s}$. During this period, the device is in transition state from normal operation mode to self refresh mode. If $t_{\text{RASS}} \geq 100 \mu\text{s}$, then $\overline{\text{RAS}}$ precharge time should use t_{RPS} instead of t_{RP} .
24. CBR burst refresh or 4096 cycles of distributed CBR refresh with $15.6 \mu\text{s}$ interval should be executed within 64 ms immediately after exiting from and before entering into the self refresh mode.
25. Repetitive self refresh mode without refreshing all memory is not allowed. Once you exit from self refresh mode, all memory cells need to be refreshed before re-entering the self refresh mode again.
26. XXX: H or L (H: $V_{\text{IH}}(\text{min}) \leq V_{\text{IN}} \leq V_{\text{IH}}(\text{max})$, L: $V_{\text{IL}}(\text{min}) \leq V_{\text{IN}} \leq V_{\text{IL}}(\text{max})$)
/////: Invalid Dout
When the address, clock and input pins are not described on timing waveforms, their pins must be applied V_{IH} or V_{IL} .

HB56HW465DB-A Series

Notes concerning $2\overline{\text{CAS}}$ control

Please do not separate the $2\overline{\text{CAS}}$ s ($\overline{\text{CAS0}}$ and $\overline{\text{CAS1}}$ (or $\overline{\text{CAS2}}$, $\overline{\text{CAS4}}$, $\overline{\text{CAS6}}$ and $\overline{\text{CAS3}}$, $\overline{\text{CAS5}}$, $\overline{\text{CAS7}}$)) operation timing intentionally. However skew between $2\overline{\text{CAS}}$ s are allowed under the following conditions.

1. Each of the $2\overline{\text{CAS}}$ s should satisfy the timing specifications individually.
2. Different operation mode for upper/lower byte is not allowed: such as following.

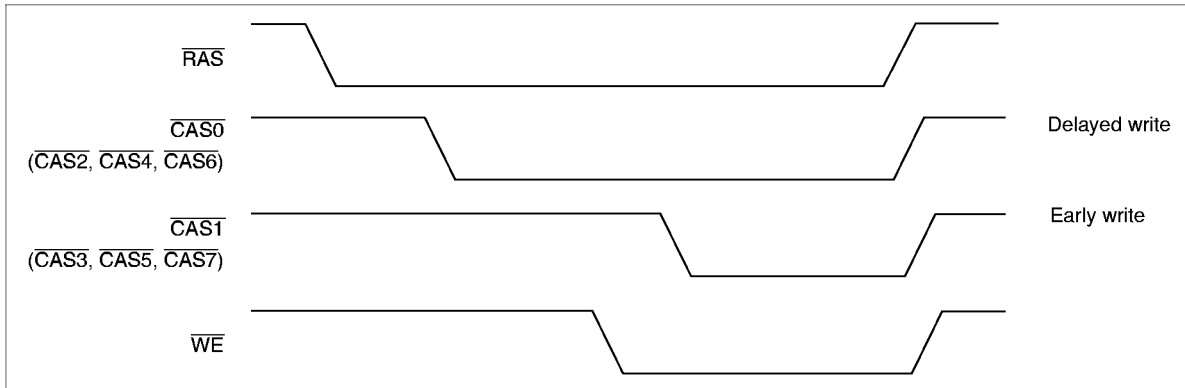

3. Closely separated upper/lower byte control is not allowed. However when the condition ($t_{\text{CP}} \leq t_{\text{UL}}$) is satisfied, EDO page mode can be performed.

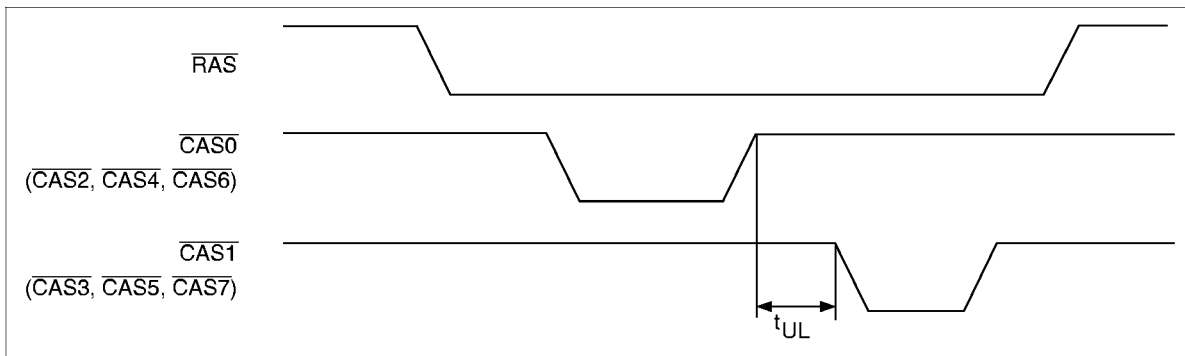

4. Byte control operation by remaining $\overline{\text{CAS0}}$ ($\overline{\text{CAS2}}$, $\overline{\text{CAS4}}$, $\overline{\text{CAS6}}$) or $\overline{\text{CAS1}}$ ($\overline{\text{CAS3}}$, $\overline{\text{CAS5}}$, $\overline{\text{CAS7}}$) high is guaranteed.

Timing Waveforms*26

Read Cycle

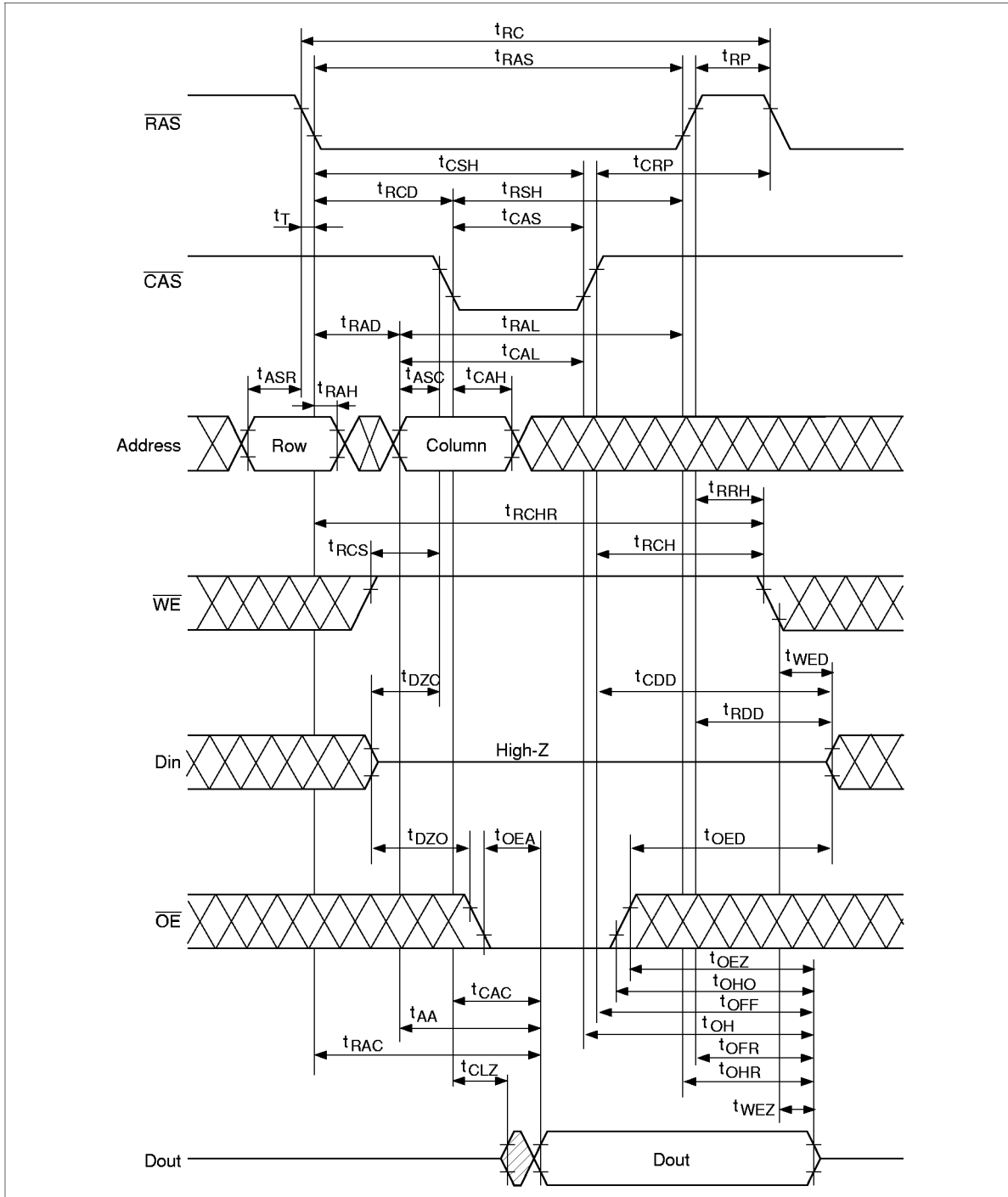

Early Write Cycle

HB56HW465DB-A Series

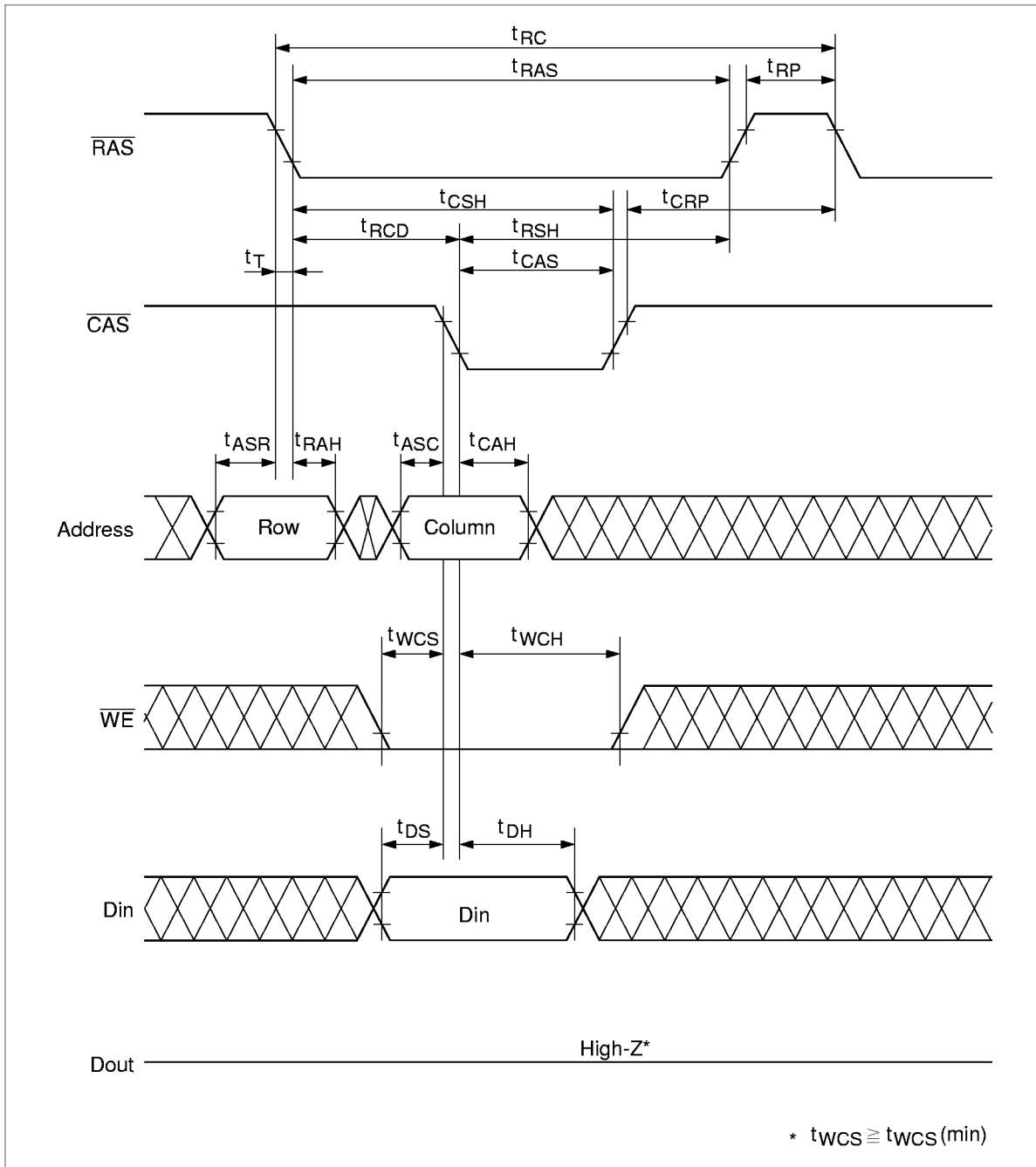

Delayed Write Cycle*19

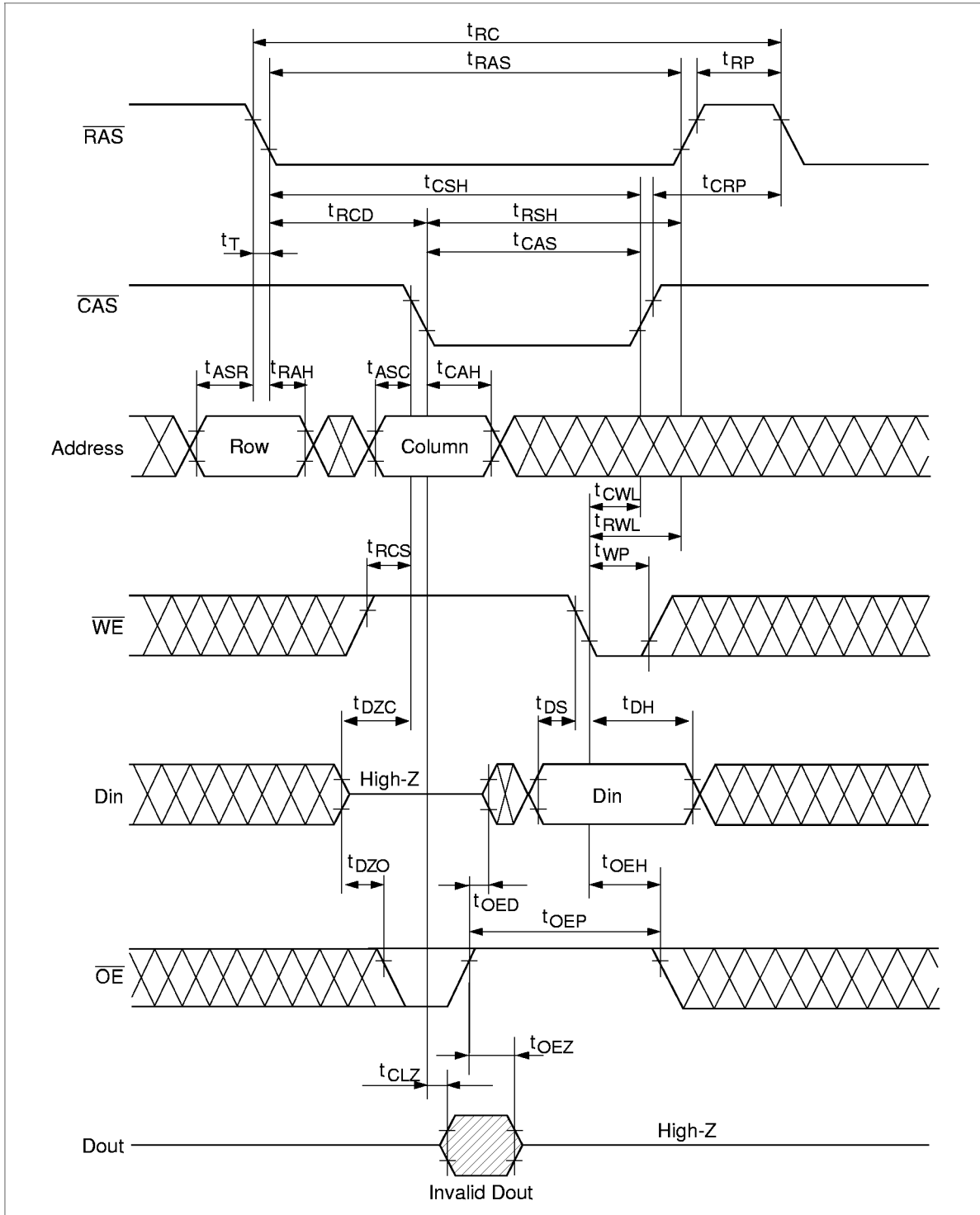

$\overline{\text{RAS}}$ -Only Refresh Cycle

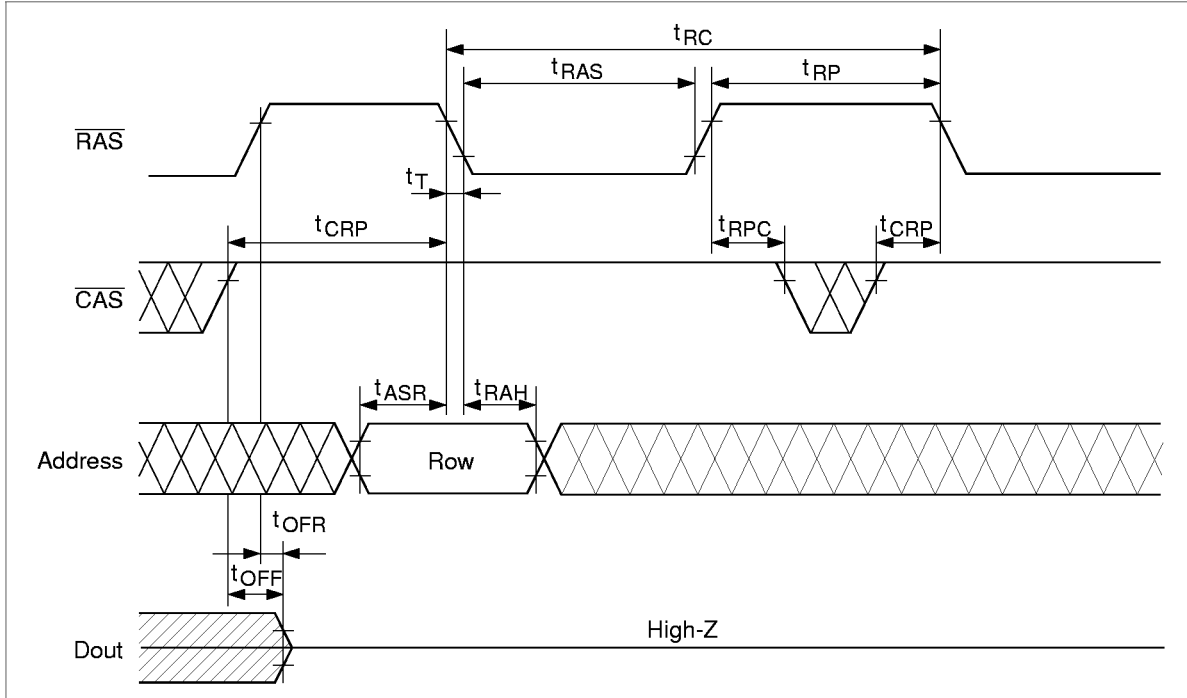

HB56HW465DB-A Series

$\overline{\text{CAS}}$ -Before- $\overline{\text{RAS}}$ Refresh Cycle

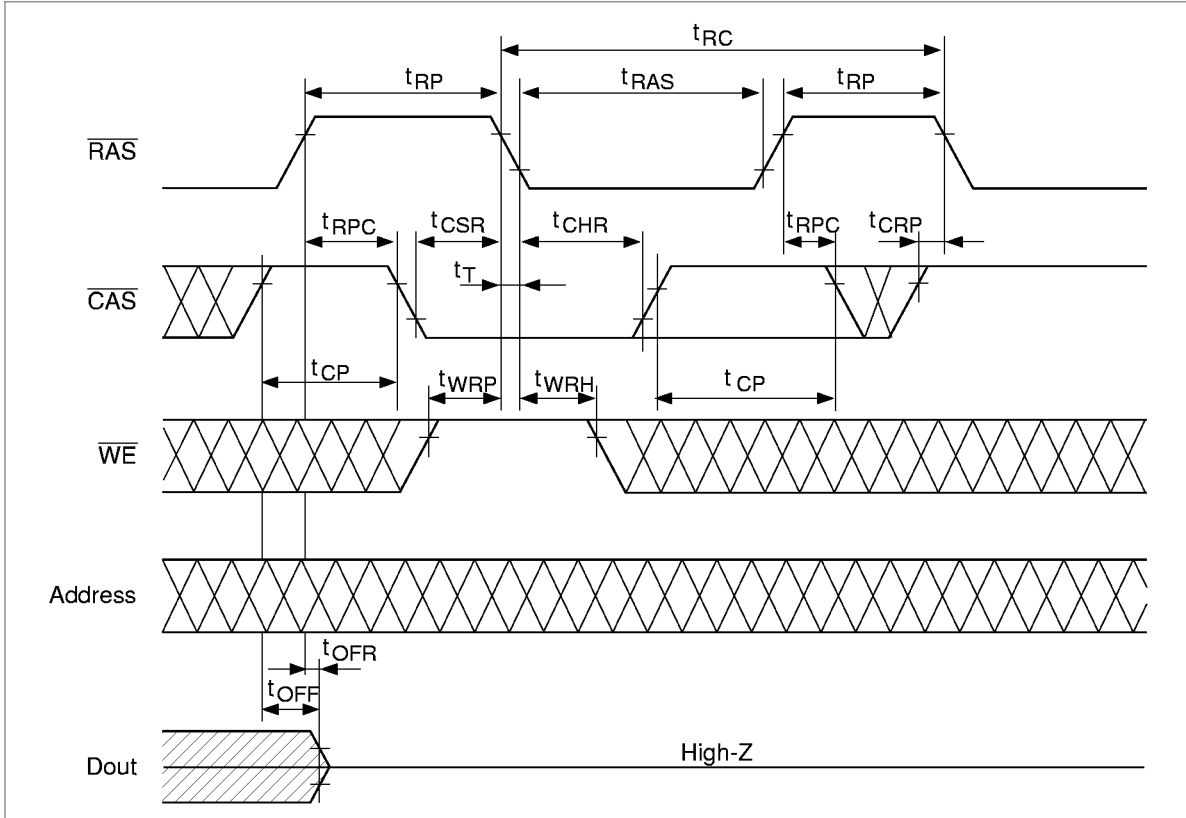

Hidden Refresh

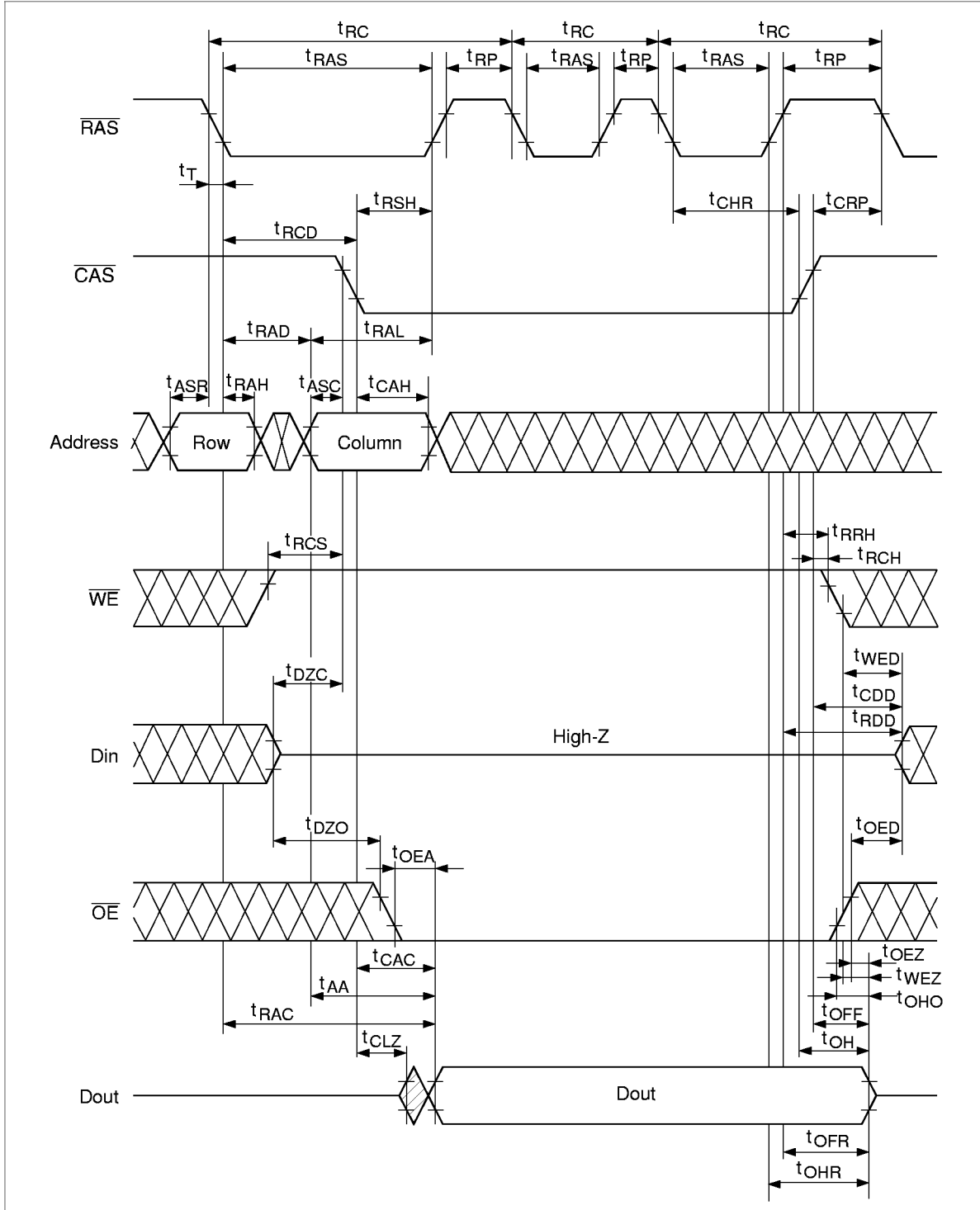

HB56HW465DB-A Series

EDO Page Mode Read Cycle

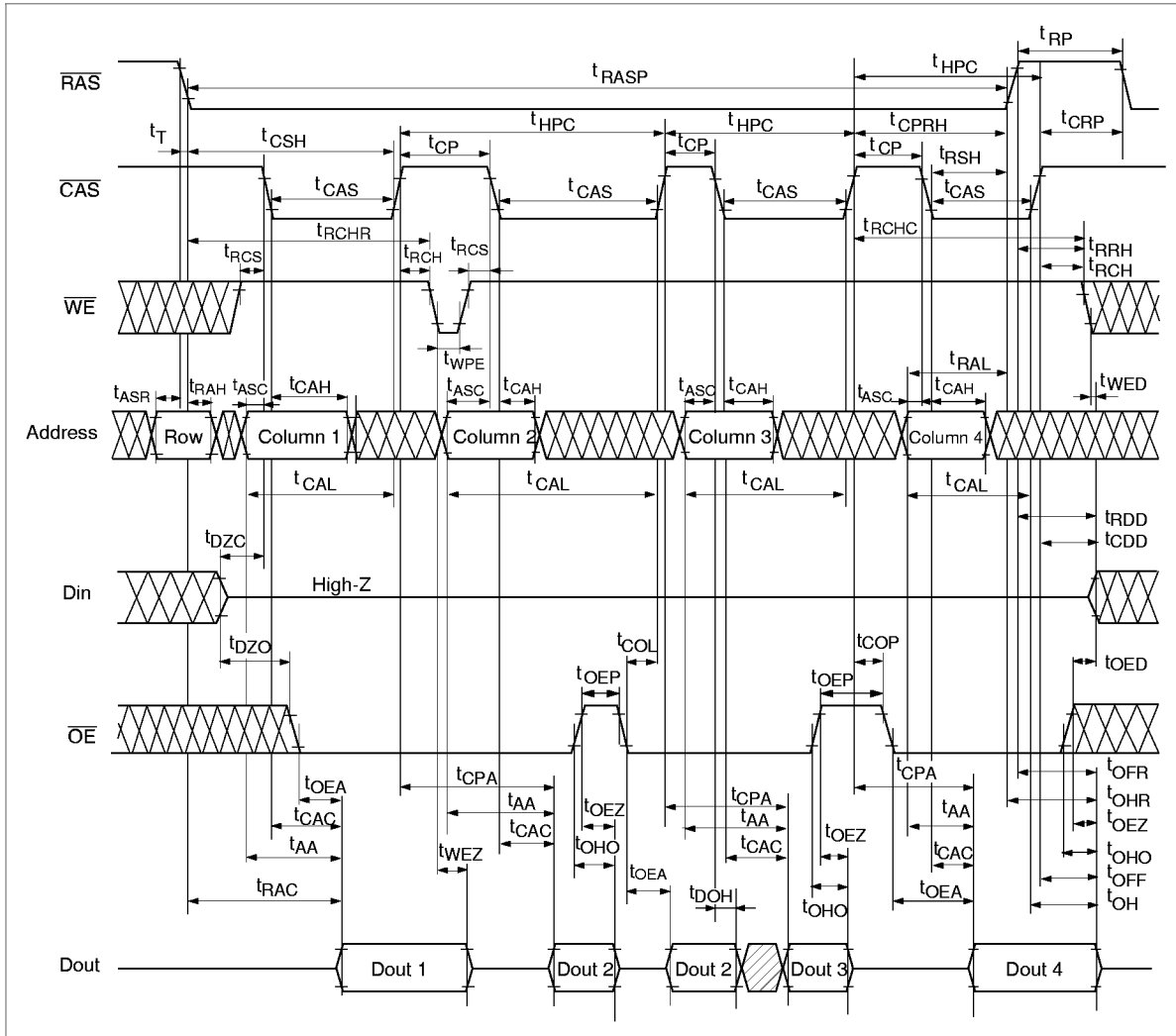

EDO Page Mode Early Write Cycle

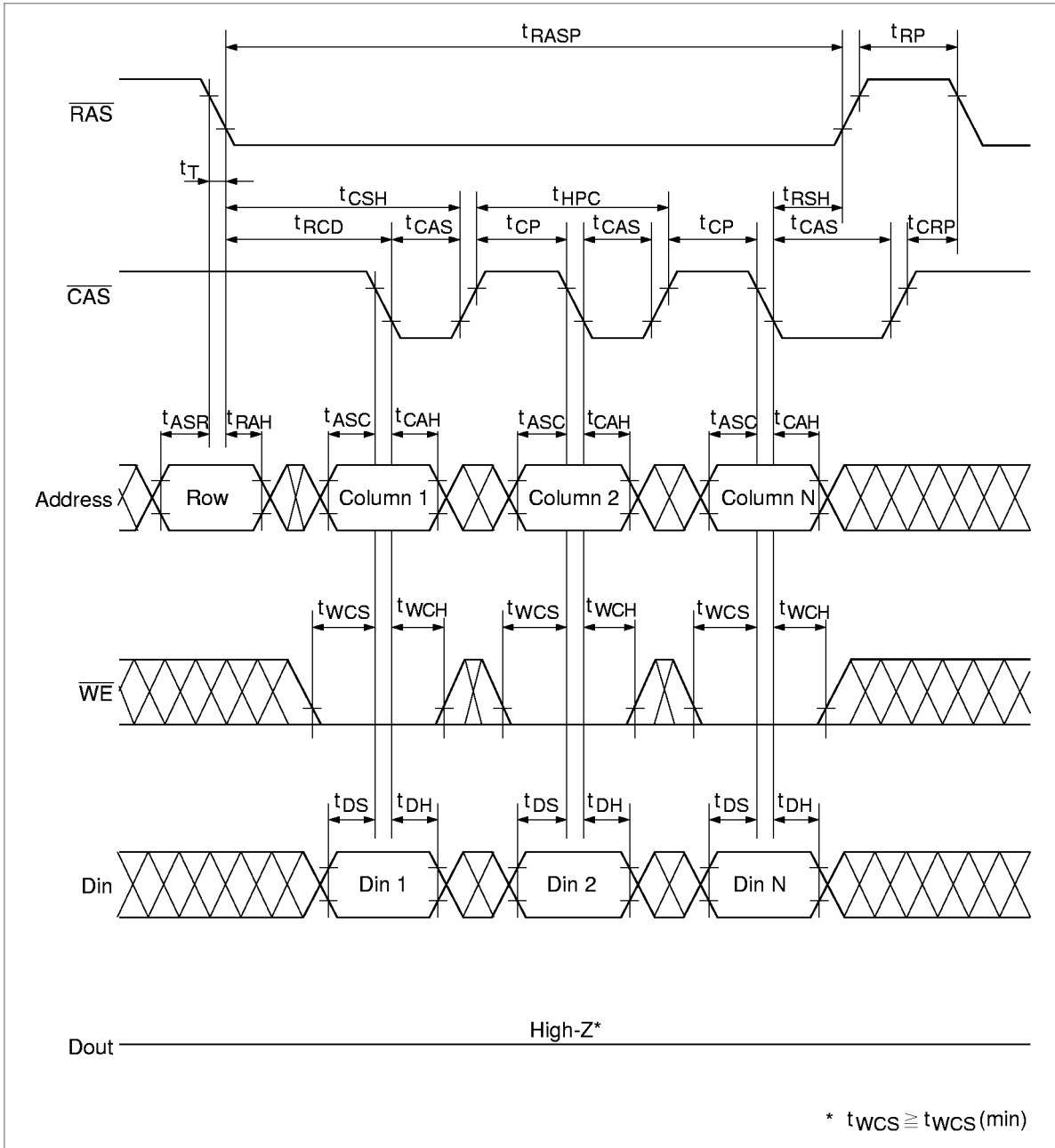

HB56HW465DB-A Series

EDO Page Mode Delayed Write Cycle*19

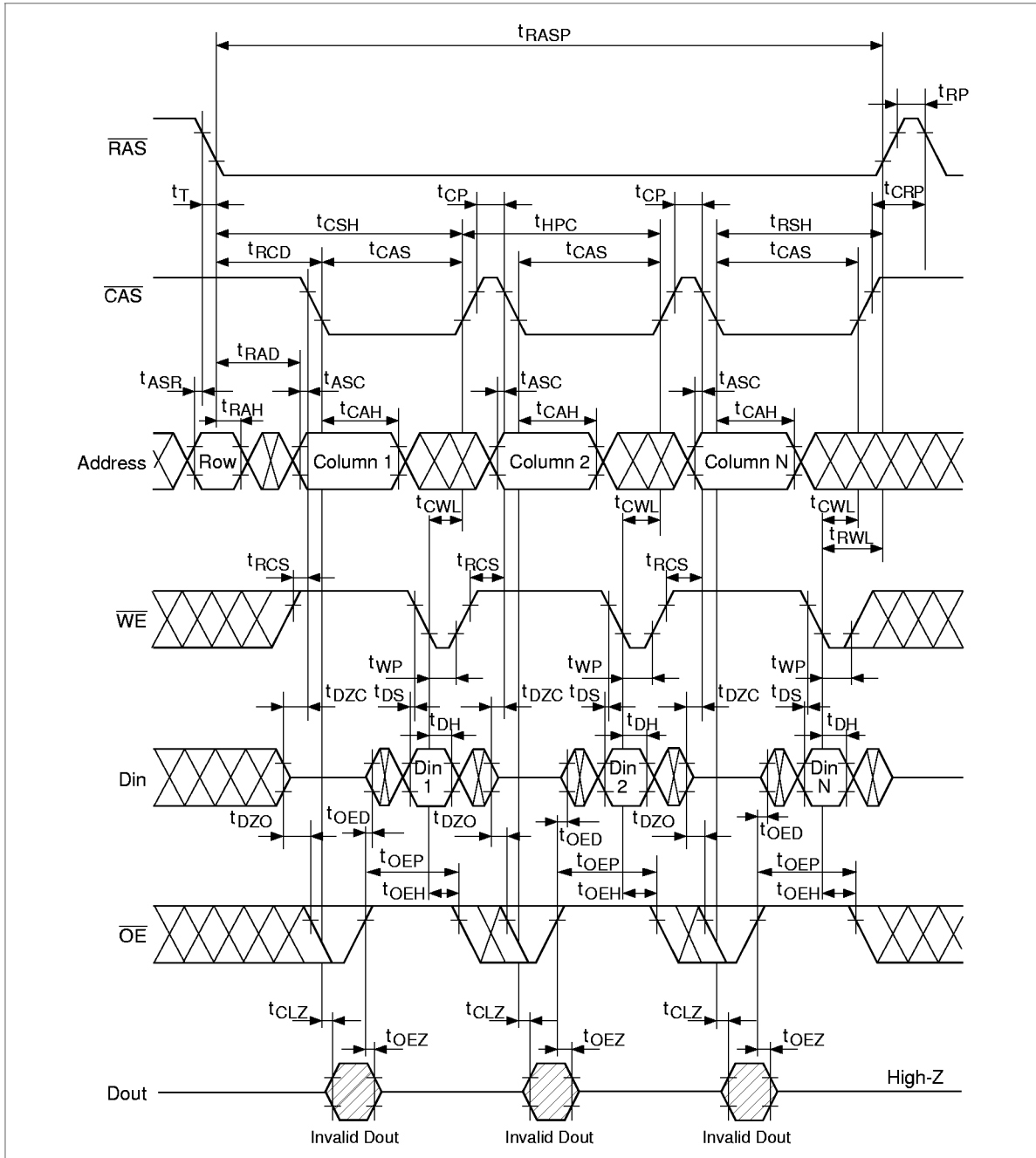

EDO Page Mode Read-Modify-Write Cycle^{*19}

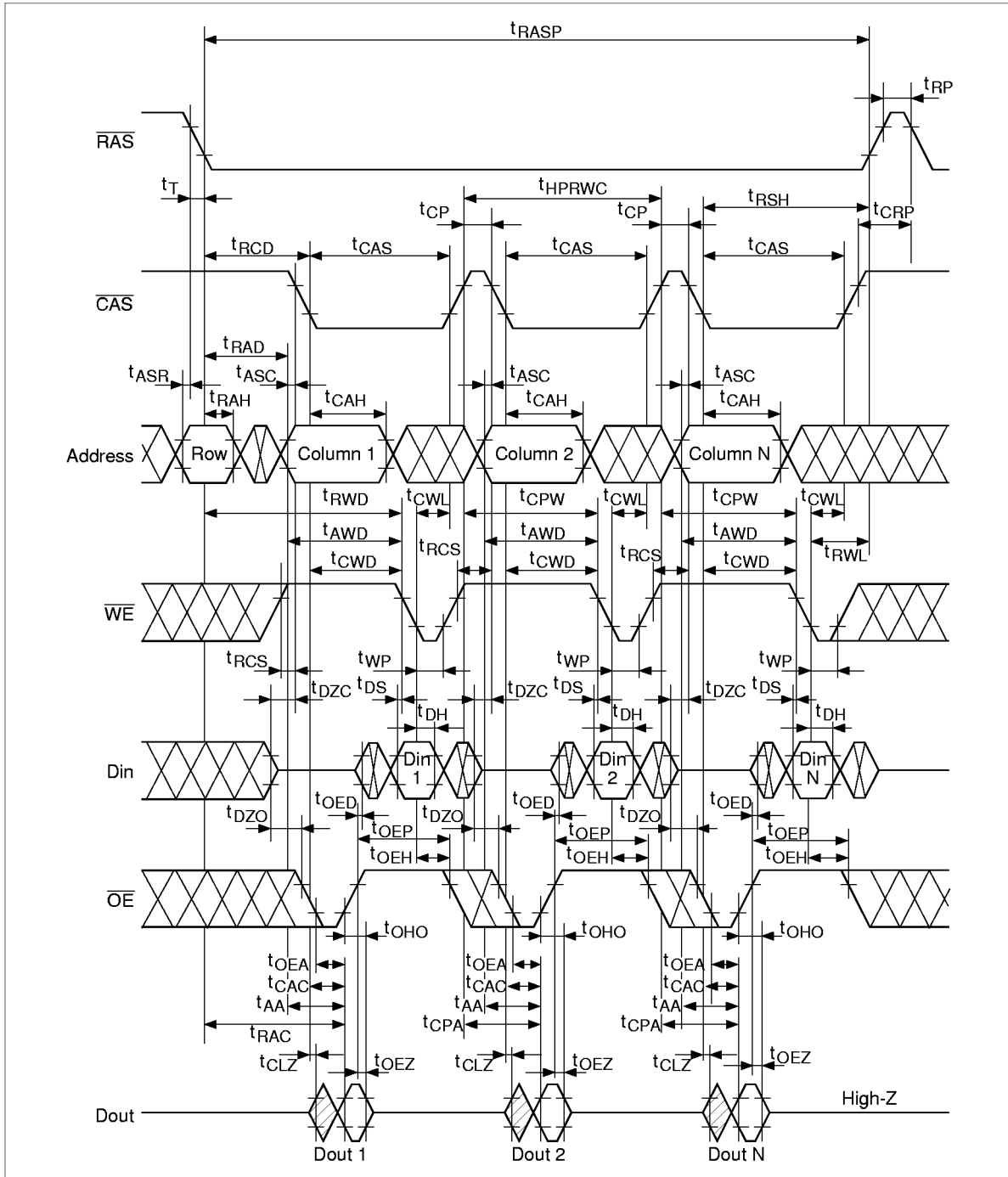

HB56HW465DB-A Series

EDO Page Mode Mix Cycle (1)*20

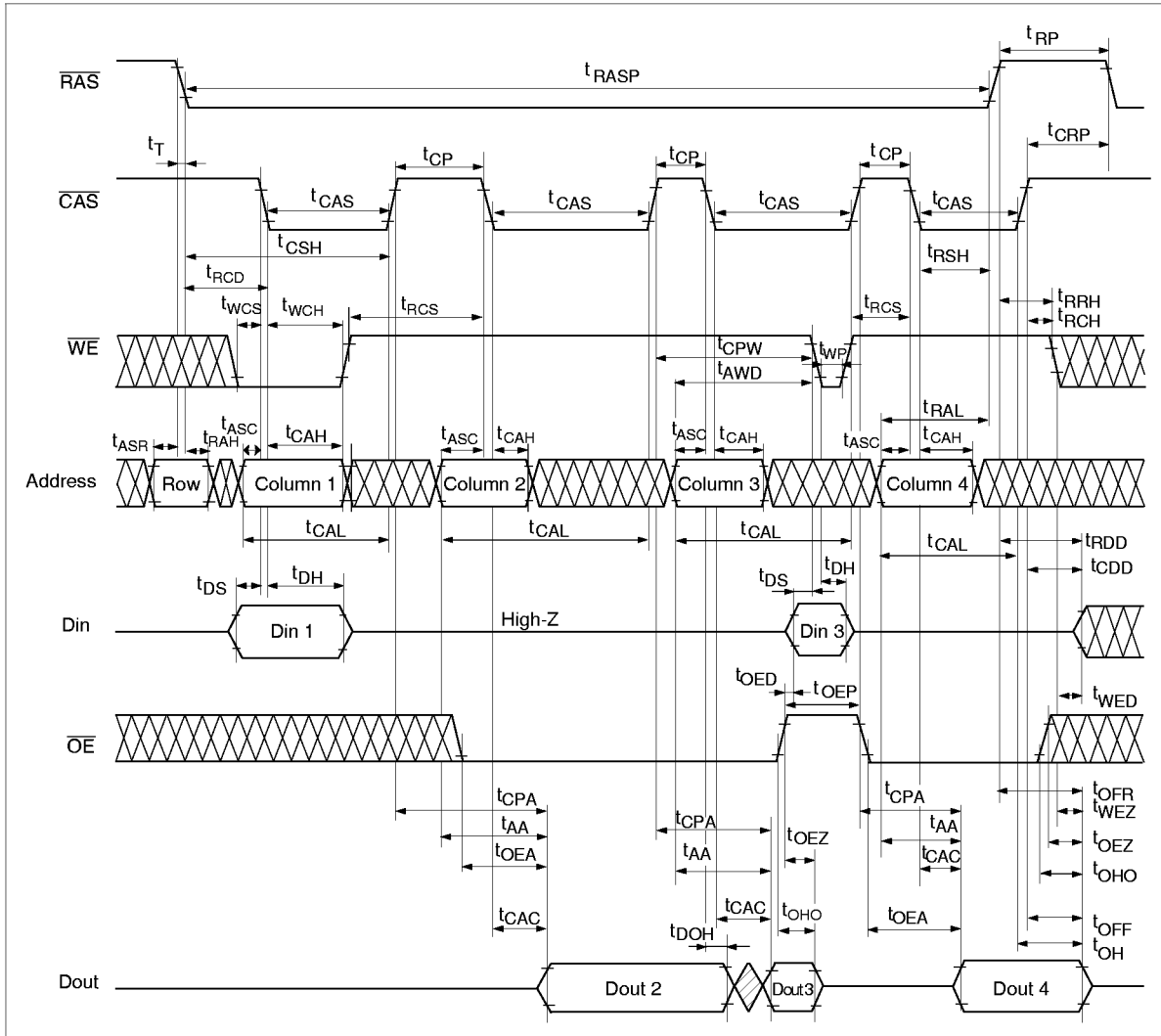

HB56HW465DB-A Series

Self Refresh Mode Cycle*23, 24, 25

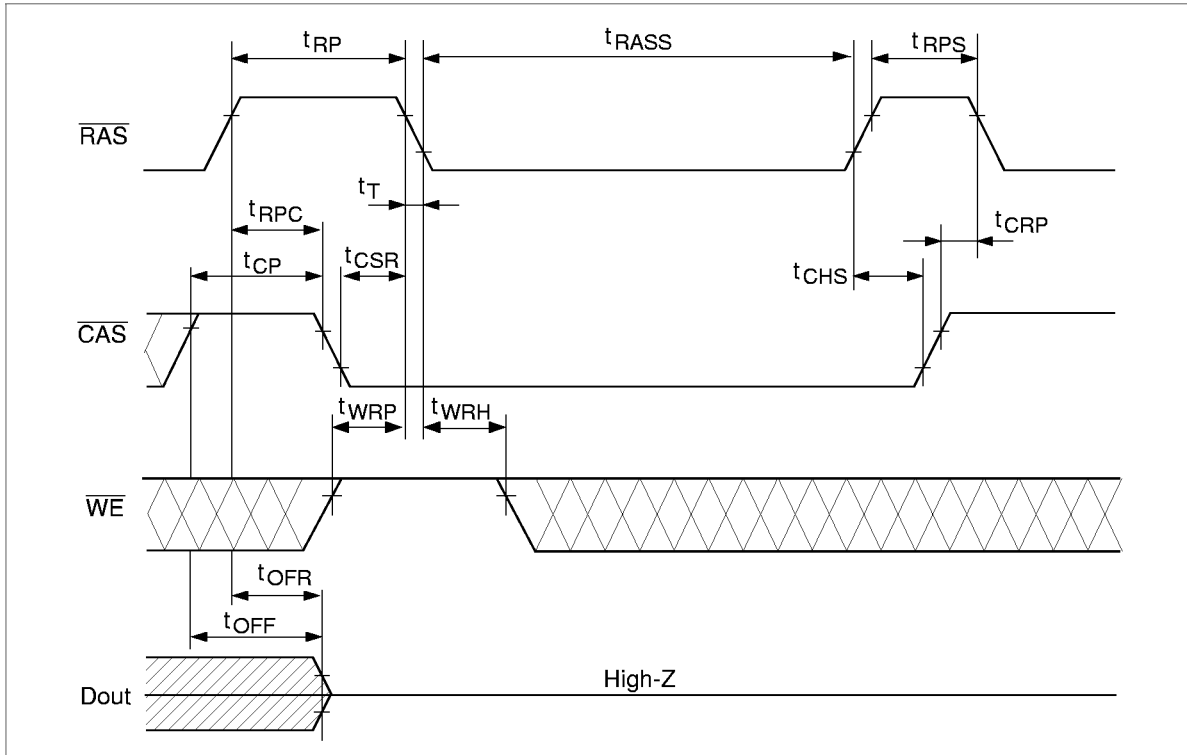

Physical Outline

HB56HW465DB-A Series

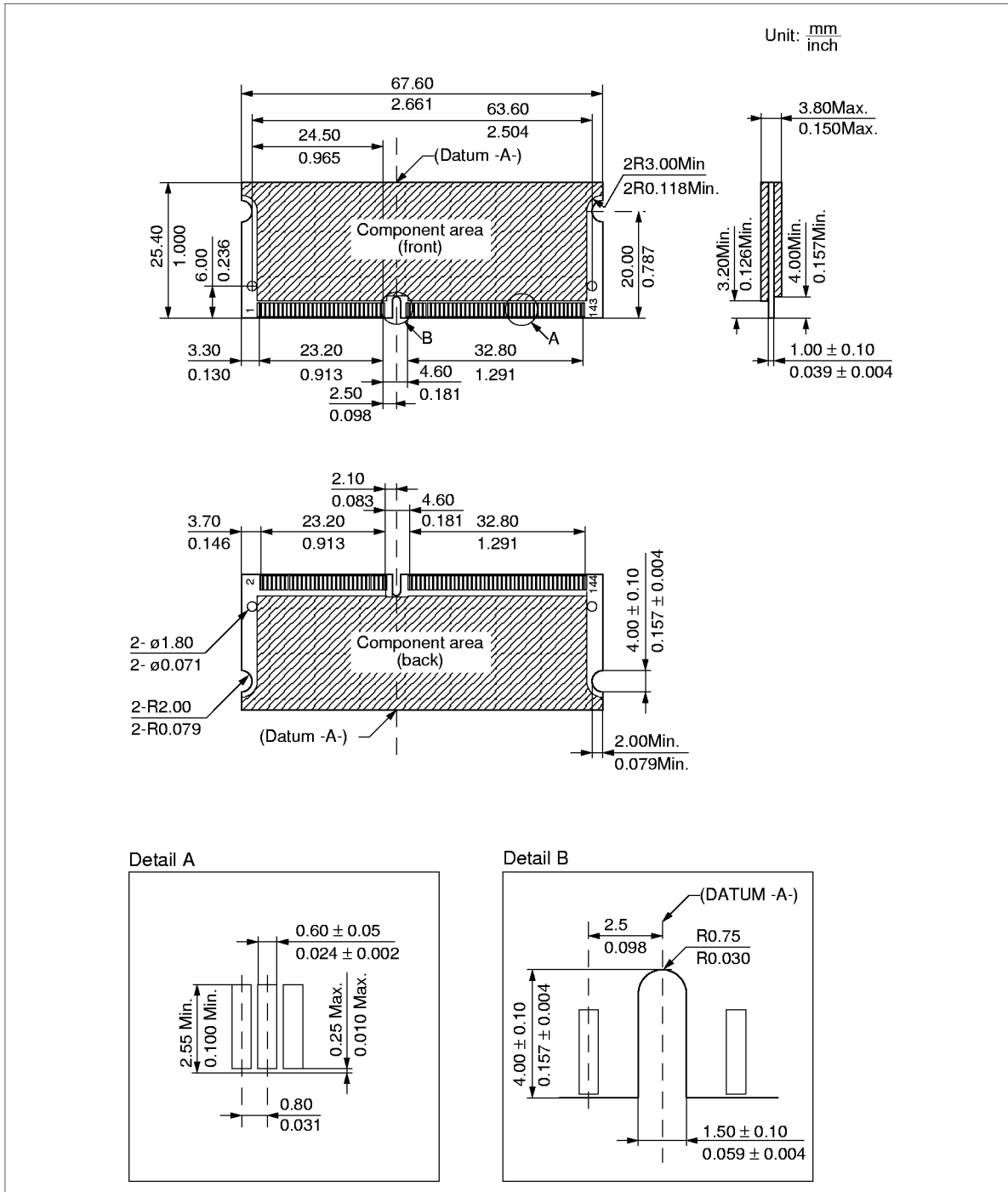

HB56HW465DB-A Series

When using this document, keep the following in mind:

1. This document may, wholly or partially, be subject to change without notice.
2. All rights are reserved: No one is permitted to reproduce or duplicate, in any form, the whole or part of this document without Hitachi's permission.
3. Hitachi will not be held responsible for any damage to the user that may result from accidents or any other reasons during operation of the user's unit according to this document.
4. Circuitry and other examples described herein are meant merely to indicate the characteristics and performance of Hitachi's semiconductor products. Hitachi assumes no responsibility for any intellectual property claims or other problems that may result from applications based on the examples described herein.
5. No license is granted by implication or otherwise under any patents or other rights of any third party or Hitachi, Ltd.
6. **MEDICAL APPLICATIONS:** Hitachi's products are not authorized for use in **MEDICAL APPLICATIONS** without the written consent of the appropriate officer of Hitachi's sales company. Such use includes, but is not limited to, use in life support systems. Buyers of Hitachi's products are requested to notify the relevant Hitachi sales offices when planning to use the products in **MEDICAL APPLICATIONS**.

HITACHI

Hitachi, Ltd.

Semiconductor & IC Div.
Nippon Bldg., 2-6-2, Ohte-machi, Chiyoda-ku, Tokyo 100, Japan
Tel: Tokyo (03) 3270-2111
Fax: (03) 3270-5109

For further information write to:

Hitachi America, Ltd.
Semiconductor & IC Div.
2000 Sierra Point Parkway
Brisbane, CA. 94005-1835
U S A
Tel: 415-589-8300
Fax: 415-583-4207

Hitachi Europe GmbH
Continental Europe
Dornacher Straße 3
D-85622 Feldkirchen
München
Tel: 089-9 91 80-0
Fax: 089-9 29 30-00

Hitachi Europe Ltd.
Electronic Components Div.
Northern Europe Headquarters
Whitebrook Park
Lower Cookham Road
Maidenhead
Berkshire SL6 8YA
United Kingdom
Tel: 01628-585000
Fax: 01628-585160

Hitachi Asia Pte. Ltd.
16 Collyer Quay #20-00
Hitachi Tower
Singapore 049318
Tel: 535-2100
Fax: 535-1533

Hitachi Asia (Hong Kong) Ltd.
Unit 706, North Tower,
World Finance Centre,
Harbour City, Canton Road
Tsim Sha Tsui, Kowloon
Hong Kong
Tel: 27359218
Fax: 27306071

Copyright © Hitachi, Ltd., 1997. All rights reserved. Printed in Japan.

HB56HW465DB-A Series

Revision Record

Rev.	Date	Contents of Modification	Drawn by	Approved by
1.0	Sep. 19, 1997	Initial issue (referred to HM5164165A/5165165A Series rev. 1.0)		
