



Fast Switching Plastic Rectifier

Major Ratings and Characteristics

$I_{F(AV)}$	8.0 A
V_{RRM}	200 V to 800 V
I_{FSM}	100 A
t_{rr}	145 ns
V_F	1.85 V
$T_j \text{ max}$	150 °C

Features

- Glass passivated chip junction
- Superfast recovery time for high efficiency
- Low leakage current
- High forward surge capability
- Meets MSL level 1, per J-STD-020C

Typical Applications

For use in fast switching rectification of power supply, inverters, converters and freewheeling diodes application

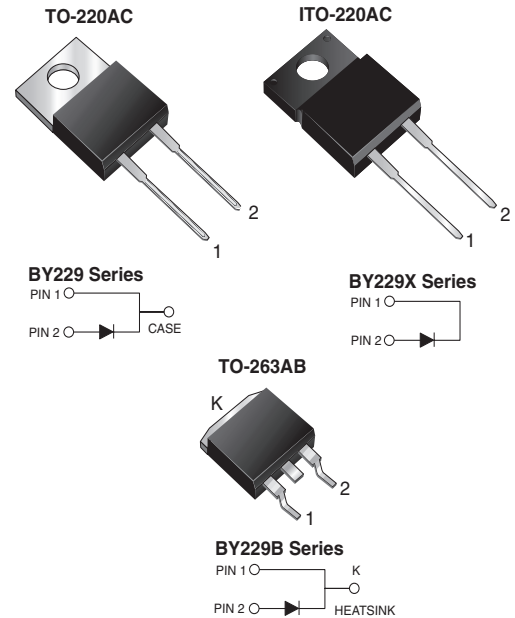

Mechanical Data

Case: TO-220AC, ITO-220AC, TO-263AB

Epoxy meets UL 94V-0 Flammability rating

Terminals: Matte tin plated (E3 Suffix) leads, solderable per J-STD-002B and MIL-STD-750, Method 2026

Polarity: As marked

Mounting Torque: 10 in-lbs maximum

Maximum Ratings

($T_C = 25\text{ °C}$, unless otherwise noted)

Parameter	Symbol	BY229-200	BY229-400	BY229-600	BY229-800	Unit
Maximum recurrent peak reverse voltage	V_{RRM}	200	400	600	800	V
Maximum RMS voltage	V_{RMS}	140	280	420	560	V
Maximum DC blocking voltage	V_{DC}	200	400	600	800	V
Maximum average forward rectified current at $T_C = 100\text{ °C}$	$I_{F(AV)}$	8.0				A
Peak forward surge current 8.3 ms single half sine-wave superimposed on rated load	I_{FSM}	100				A
Maximum slope of reverse recovery current $I_F = 2.0\text{ A}$, $V_R = 30\text{ V}$, $di/dt = 20\text{ }\mu\text{s}$	di/dt	60				A/ μs
Operating junction and storage temperature range	T_J, T_{STG}	- 40 to + 150				°C
RMS Isolation voltage from terminals to heatsink with $t = 1\text{ second}$, $RH \leq 30\%$ (BY229X only)	V_{ISOL}	4500 ⁽¹⁾ 3500 ⁽²⁾ 1500 ⁽³⁾				V



Electrical Characteristics

($T_C = 25\text{ }^\circ\text{C}$ unless otherwise noted)

Parameter	Test condition	Symbol	BY229-200	BY229-400	BY229-600	BY229-800	Unit
Maximum instantaneous forward voltage	at 20 A ⁽⁴⁾	V_F	1.85				V
Maximum DC reverse current at rated DC blocking voltage	$T_J = 25\text{ }^\circ\text{C}$ $T_J = 125\text{ }^\circ\text{C}$	I_R	10 300				μA
Maximum reverse recovery time	at $I_F = 1.0\text{ A}$, $V_R = 30\text{ V}$, $di/dt = 50\text{ A}/\mu\text{s}$, $I_{rr} = 10\% I_{RM}$	t_{rr}	145				ns
Maximum recovered stored charge	$I_F = 2.0\text{ A}$, $V_R = 30\text{ V}$, $di/dt = 20\text{ A}/\mu\text{s}$	Q_{rr}	700				nC

Notes:

- (1) Clip mounting (on case), where lead does not overlap heatsink with 0.110" offset
- (2) Clip mounting (on case), where leads do overlap heatsink
- (3) Screw mounting with 4-40 screw, where washer diameter is $\leq 4.9\text{ mm}$ (0.19")
- (4) Pulse test: 300 μs pulse width, 1 % duty cycle

Thermal Characteristics

($T_C = 25\text{ }^\circ\text{C}$ unless otherwise noted)

Parameter	Symbol	BY229	BY229X	BY229B	Unit
Typical thermal resistance, junction to case	$R_{\theta JC}$	2.0	4.8	2.0	$^\circ\text{C}/\text{W}$
Typical thermal resistance, junction to air	$R_{\theta JA}$	20	-	20	$^\circ\text{C}/\text{W}$



Ratings and Characteristics Curves

($T_A = 25\text{ }^\circ\text{C}$ unless otherwise noted)

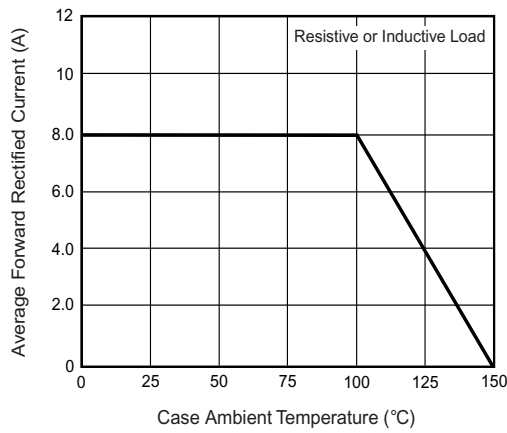

Figure 1. Forward Current Derating Curve

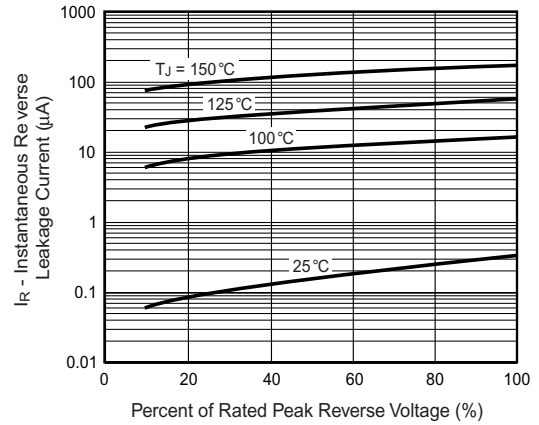

Figure 4. Typical Reverse Leakage Characteristics

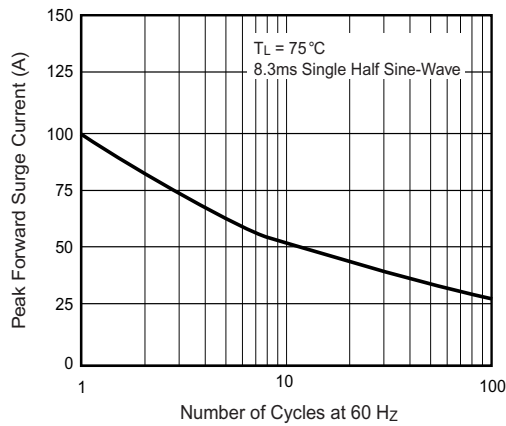

Figure 2. Maximum Non-Repetitive Peak Forward Surge Current

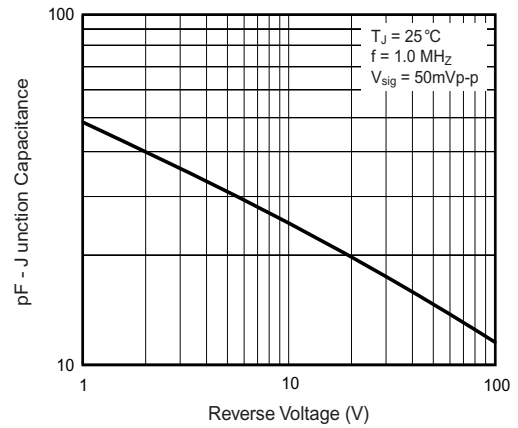

Figure 5. Typical Junction Capacitance

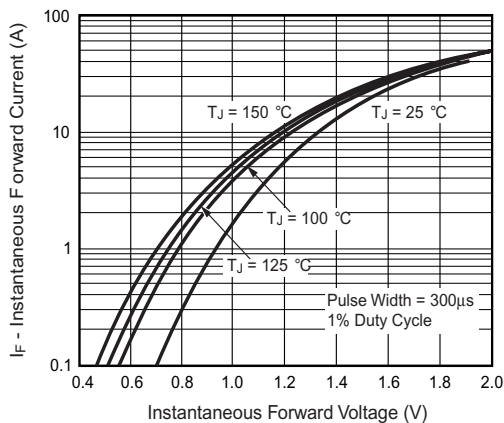
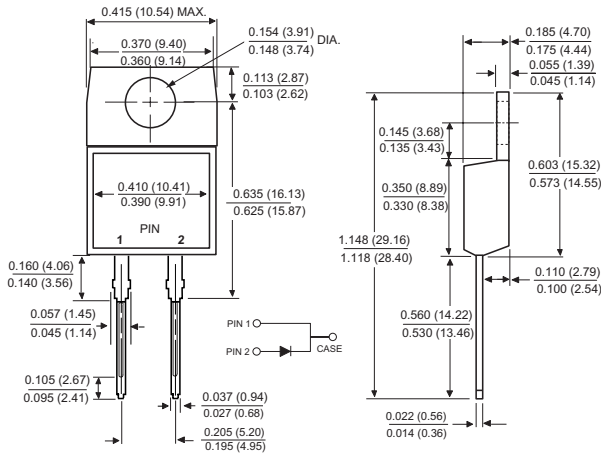

Figure 3. Typical Instantaneous Forward Characteristics

Package outline dimensions in inches (millimeters)

TO-220AC



ITO-220AC

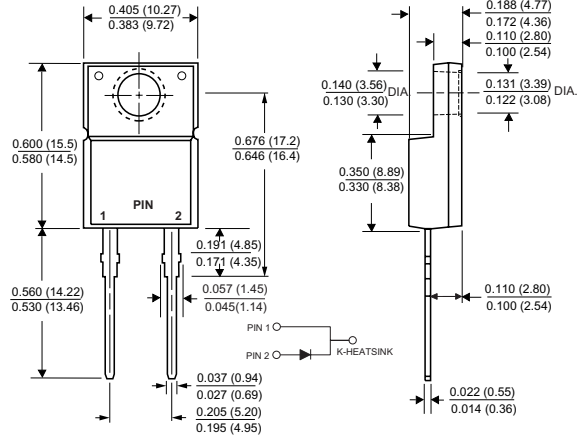

TO-263AB

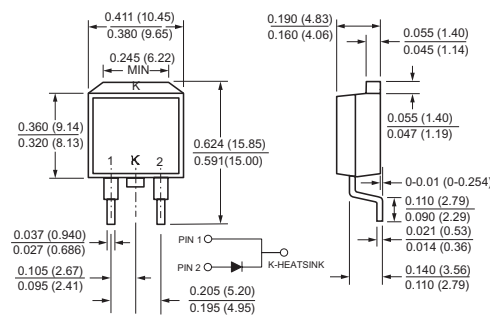

Mounting Pad Layout

