

# FCX – AX SERIES DIFFERENTIAL PRESSURE TRANSMITTER

## Hydroseal® Diaphragm Version

DATA SHEET

FHC, FKC...3

### FEATURES

**1. Unique hydroseal diaphragm**

Permeation of hydrogen into the detecting unit through seal diaphragm can be suppressed thanks to the unique seal diaphragm (double coating) which employs coating of gold and ceramic.

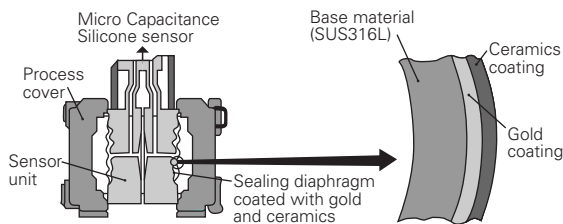

**2. High accuracy**

±0.15% accuracy for all calibrated spans is the standard feature for differential pressure (flow) transmitter covering 3.2 to 130kPa (or 320mm to 13 mH<sub>2</sub>O). Fuji's Micro-capacitance silicon sensor assures this feature.

**3. Minimum environment influence**

Fuji's patented "Advanced Floating Cell" design which protects the pressure sensor against changes in temperature, static pressure, and overpressure substantially reduces total measurement error in actual field applications.

**4. Replaceable Communication Module**

Fuji micro-electronics manufacturing technology offers replaceable communication module the makes FCX-AX transmitter very unique in design. In case of change in communication protocol, all that needs to be done is just to replace the module and the transmitter gets upgraded to the new version.

**5. Fuji/HART bilingual communication module**

The communication module is "bilingual" to speak both Fuji proprietary protocol and HART. Any HART compatible devices can communicate with FCX-AX series transmitters.

**6. Application flexibility**

- Various options that render the FCX-AX series suitable for almost any process applications include.
- Analog indicator at either the electronics side or terminal side
  - Full range of hazardous location approvals
  - 4 ½ -digit LCD meter
  - Stainless steel electronics housing
  - Built-in RFI filter and lightning arrester



**7. Programmable output Linearization Function**

In addition to Linear and Square Root, output signal can be freely programmable. (Up to 14 compensated points at approximation.) (Available for amplifier unit from version 24 and FXW(HHC) version 5.3.)

**8. Burnout current flexibility (Under Scale: 3.2 to 3.8mA, Over Scale: 20.8 to 21.6mA)**

Burnout signal level is adjustable using Model FXW hand Held Communicator (HHC) to comply with NAMUR NE43. (Available for amplifier unit from version 24 and FXW(HHC) version 5.3.)

**9. Dry calibration without reference pressure**

Thanks to the best combination of unique construction of mechanical parts (Sensor unit) and high performance electronics circuit (Electronics unit), reliability of dry calibration without reference pressure is at equal level as wet calibration.

### SPECIFICATIONS

**Functional specifications**

**Type:**

Model FHC: 4 to 20mA, Traditional type

Model FKC: 4 to 20mA with digital signal, Smart type

**Service:**

Liquid, gas, or vapour

**Static pressure, span, and range limit:**

Type	Static pressure [MPa] (bar)	Span limit [kPa] (mbar)			Range limit [kPa] (m bar)
		Min.		Max. FHC/FKC	
		FHC	FKC		
F□C □ 33	-0.1 to 16 (-1 to + 160)	( 3.2 ) ( 32 )	0.32 ( 3.2 )	32 ( 320 )	+/- 32 (+/- 320)
F□C □ 35	-0.1 to 16 (-1 to + 160)	13 ( 130 )	1.3 ( 13 )	130 ( 1300 )	+/- 130 (+/- 1300)

- Lower limit of static pressure (vacuum limit) ;  
Silicone fill sensor: See Fig. 1  
Fluorinated fill sensor: 66kPa abs (500mmHg abs)  
at temperature below 80°C
- The maximum span of each sensor can be converted to different units using below factors.  
1MPa= 10<sup>3</sup>KPa=10bar=10.19716kgf/cm<sup>2</sup>=  
145.0377psi  
1kpa=10mbar=101.9716mmH<sub>2</sub>O=4.01463inH<sub>2</sub>O

**Overrange limit:** To maximum static pressure limit

**Output signal:**

Model FHC: 4 to 20mA DC 2-wire, linear signal

Model FKC: 4 to 20mA DC (linear or square root) with digital signal superimposed on the 4 to 20mA signal

**Power supply:** Transmitter operates on 10.5V to 45V DC at transmitter terminals.  
10.5V to 32V DC for the units with optional arrester.

**Load limitations:** see figure below

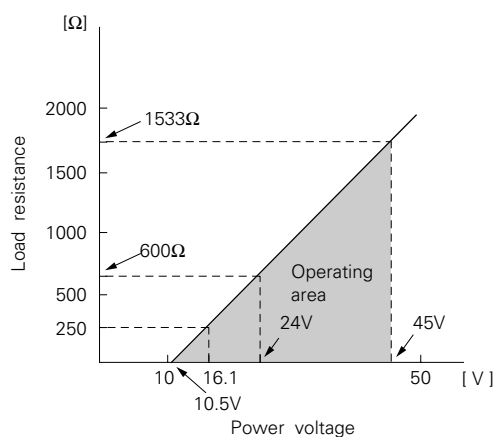

Note: For communication with HHC (Model: FXW), min. of 250Ω required.

**Hazardous locations: (Approval pending)**

Authorities	Flameproof	Intrinsic safety	Type N Nonincendive
BASEEFA Factory Mutual	Ex ds IIC T5, T6 Class I II III Div. 1 Groups B thru. G	EEx ia IIC T4, T5 Class I II III Div. 1 Groups A thru. F	Ex N II T5 Class I II III Div. 2 Groups A thru. G
CSA	Class I II III Div. 1 Groups C thru. G	Class I II III Div. 1 Groups A thru. G	Class I II III Div. 2 Groups A thru. G
RIIS SAA	Ex ds IIB+H <sub>2</sub> T4 Ex d II C T5, T6 IP 66/67	— Ex ia II C T5, T6 IP 66/67	— Ex n II C T5, T6 IP 66/67

**Zero/span adjustment:**

Model FHC: Zero is adjustable from the external adjustment screw.

The adjustment screw can also function to adjust span when MODE SWITCH (located on the electronics unit) is in the span mode. INHIBIT mode to disable the adjustment screw is also available.

Model FKC: Zero and span are adjustable from the HHC. Zero is also adjustable externally from the adjustment screw.

**Damping:** Adjustable electrical damping.

Model FHC: The time constant is adjustable to 0, 0.3, 1.2, 4.8, or 19.2 seconds.

Model FKC: The time constant is adjustable between 0 to 38.4 seconds. (4 steps)

**Zero elevation/suppression:**

-100% to +100% of URL

**Normal/reverse action:**

Model FHC: Selectable by moving a jumper pin located on the electronics unit.

Model FKC: Selectable from HHC

**Indication:** Analog indicator or 4½-digit LCD meter, as specified.

**Burnout direction:** If self-diagnostic detect transmitter failure, the analog signal will be driven to either "Output Hold", "Output Overscale" or "Output Underscale" modes.

Model FHC: Unless otherwise specified in the order, the transmitter will be shipped in "Output Hold" mode.

(Output signal just before failure happens is maintained.)

Model FKC: Selectable from HHC

"Output Hold":

Output signal is hold as the value just before failure happens.

"Output Overscale":

Approx. 21.6mA

(Adjustable within the range 20.8mA to 21.6mA from HHC)

"Output Underscale":

Approx. 3.8mA

(Adjustable within the range 3.2mA to 3.8mA from HHC)

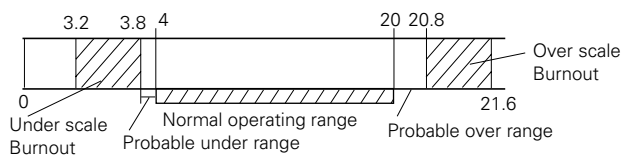

**Loop-check output:**

Model FHC: Transmitter can output constant signal of 4mA, 12mA, or 20mA if MODE SWITCH is set to the loop check mode.

Model FKC: Transmitter can be configured to provide constant signal 3.8mA through 21.6mA by HHC.

**Temperature limit:** Ambient: -40 to +85°C

(-20 to +80°C for LCD indicator)

(-40 to +60°C for arrester option)

(-10 to +60°C for fluorinated oil filled transmitters)

For explosionproof units (flameproof or intrinsic safety), ambient temperature must be within the limits specified in each standard.

Process: -40 to +120°C for silicone fill sensor

-20 to +80°C for fluorinated oil fill sensor

Storage: -40 to +90°C

**Humidity limit:** 0 to 100% RH

**Communication:** (Model FKC only)

With HHC (Model FXW, consult Data Sheet No. EDS8-47), following information can be remotely displayed or reconfigured.

Items	Display	Set
Tag No.	✓	✓
Model No.	✓	✓
Serial No.	✓	—
Engineering unit	✓	✓
Range limit	✓	—
Measuring range	✓	✓
Damping	✓	✓
Output mode	✓	✓
Burnout direction	✓	✓
Adjustment	✓	✓
Output adjust	—	✓
Data	✓	—
Self diagnoses	✓	—
Printer	—	—
External switch lock	✓	✓
Transmitter display(*)	✓	✓
Linearise (**)	✓	✓
Rerange (**)	✓	✓

Notes: (\*) HHC's version must be more than 5.0 (or FXW □□□□1-□2), to use this function.

(\*\*) HHC's version must be more than 5.3, and Amplifier unit version 24.

**Programmable output linearization function:**

In smart version, output signal can be characterized with "14 points linear approximation function" from HHC.

**Performance specifications for linear output**

**Accuracy rating:** (including linearity, hysteresis, and repeatability)

For spans greater than 1/10 of URL: ±0.15% of span

For spans below 1/10 of URL (Model FKC only):

$$\pm \left( 0.1 + 0.05 \frac{0.1 \times \text{URL}}{\text{Span}} \right) \% \text{ of span}$$

**Linearity:** 0.075% of calibrated span

**Stability:** ±0.15% of upper range limit (URL) for 24 months

**Temperature effect:**

Effects per 55°C change between the limits of -40°C and +85°C

Range code (6th digit in Code symbols)	Zero shift	Total effect
"3"/32kPa {320mbar} max. span	$\pm \left( 0.1 + 0.075 \frac{\text{URL}}{\text{Span}} \right) \% / 28^\circ\text{C}$	$\pm \left( 0.125 + 0.075 \frac{\text{URL}}{\text{Span}} \right) \% / 28^\circ\text{C}$

**Static pressure effect:**

Zero shift (% of URL)	Span shift (% of calibrated span)
±0.15%/10MPa{100bar}	-0.2%/10MPa{100bar}

**Overrange effect:**

Zero shift (% of URL)
±0.3% /16MPa {160bar} (*1)

(\*1) in case of 6th code "5"

**Supply voltage effect:**

Less than 0.05% of calibrated span per 10V

**RFI effect:**

Less than 0.2% of URL for the frequencies of 20 to 1000MHz and field strength 30 V/m when electronics covers on.

(Classification: 2-abc: 0.2% span per SAMA PMC 33.1)

**Step response:** (without electrical damping)

Range code	Time constant	Dead time
(6th digit in Code symbols)		approx. 0.3 s
"3"	0.45 s	
"5"	0.2 s	

**Mounting position effect:**

Zero shift, less than 0.12kPa {1.2m bar} for a 10° tilt in any plane.

No effect on span.

This error can be corrected by adjusting Zero.

(Double the effect for fluorinated fill sensors)

**Dielectric strength:**

500V AC, 50/60Hz 1 min., between circuit and earth.

**Insulation resistance:**

More than 100MΩ at 500V DC.

**Turn-on time:**

4 sec.

**Internal resistance for external field indicator:**

12Ω or less

**Performance specifications for square root output (Model FKC only)**

**Accuracy rating:**

Output	Span	
	over 0.1 × URL	below 0.1 × URL
50 to 100%	±0.15%	±(0.1+0.05 × 0.1 × URL/Span)%
20 to 50%	±0.375%	±2.5 × (0.1+0.05 × 0.1 × URL/Span)%
10 to 20%	±0.75%	±5 × (0.1+0.05 × 0.1 × URL/Span)%

**Temperature effect:**

effect per 55°C change between the limits of -40°C and +85°C

Range code	Shift at 20% output point
"3" through "5"	$\pm \left( 0.25 + 0.19 \frac{\text{URL}}{\text{Span}} \right) \% / 28^\circ\text{C}$

**Low flow cut-off:** Customer configurable for any point between 7 to 20% of output

**Physical specifications**

**Electrical connections:**

G1/2, 1/2-14 NPT, Pg13.5, or M20 x1.5 conduit, as specified.

**Process connections:**

1/4-18 NPT or Rc1/4 on 54mm centers, as specified.

Meets DIN 19213.

**Process-wetted parts material:**

Material code (7th digit in Code symbols)	Process cover	Diaphragm	Wetted sensor body	Vent/drain
C	316 stainless steel(*1)	316L stainless steel(*2)	316 stainless steel	316 stainless steel

Notes: \* (1) SCS14 per JIS G 5121  
 (2) The diaphragm face is coated with gold and ceramic.  
 Remark: Sensor O-rings: Viton and teflon selectable.

**Non-wetted parts material:**

Electronics housing: Low copper die-cast aluminum alloy (standard), finished with epoxy/polyurethane double coating, or 304 stainless steel, as specified.

Bolts and nuts: Cr-Mo alloy (standard), 304 stainless steel (for static pressure code "1", "2", and "3" only), or 630 stainless steel (for static pressure code "3" and "4" only). Static pressure rating for code "3" with 304 stainless steel bolts is degraded to 10MPa.

Fill fluid: Silicone oil (standard) or fluorinated oil (Daifloil)

Mounting bracket: Carbon steel with epoxy coating or 304 stainless steel, as specified

**Environmental protection:**

IEC IP67 and NEMA 4X

**Mounting:**

On 60.5mm(JIS 50A) pipe using mounting bracket, direct wall mounting, or direct process mounting.

**Mass(weight):**

Transmitter approximately 4.4kg without options.

Add; 0.5kg for mounting bracket  
 0.8kg for indicator option  
 4.5kg for stainless steel housing option

**Optional features**

**Indicator:**

A plug-in analog indicator (1.5% accuracy) can be housed in the electronics compartment or in the terminal box of the housing.

An optional 4 1/2 digits LCD meter is also available.

**Arrester:**

A built-in arrester protects the electronics from lightning surges.

Lightning surge immunity : 4KV (1.2 x 50µs)

**Oxygen service:**

Special cleaning procedures are followed throughout the process to maintain all process wetted parts oil-free.  
 The fill fluid is fluorinated oil.

**Chlorine service:**

The fill fluid is fluorinated oil.

**Degreasing:**

Process-wetted parts are cleaned, but the fill fluid is standard silicone oil. Not for use on oxygen or chlorine measurement.

**NACE specification:**

Metallic materials for all pressure boundary parts comply with NACE MR-01-75. ASTM B7M or L7M bolts and 2HM nuts (Class II) are available.

Static pressure rating for code "3" (16 MPa) is degraded to 10MPa.

**Vacuum service:**

Special silicone oil and filling procedure are applied.

See below figure.

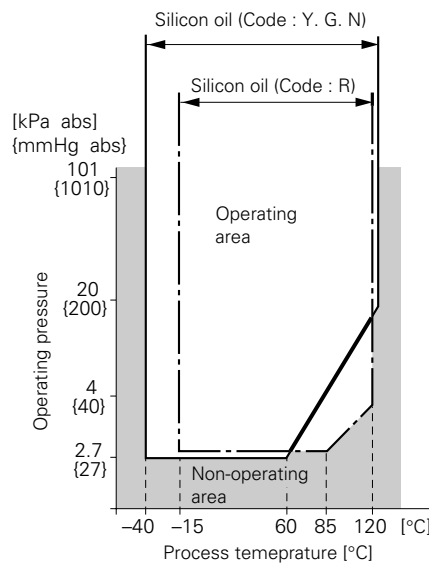

Fig. 1 Relation between process temperature and operating pressure

**Customer tag:**

A stainless steel tag with customer tag data is wired to the transmitter.

**Coating of cell:**

Cell's surface is finished with epoxy/polyurethane double coating. Specify if environment is extremely corrosive.

**ACCESSORIES**

**Oval flanges:**

(Model FFP, refer to Data Sheet No. EDS6-10)  
 Converts process connection to 1/2-14 NPT or to Rc1/2; in carbon steel or in 316 stainless steel.

**Equalizing valves:**

(Model FFN, refer to Data Sheet No. EDS6-10)  
 Available in CS or in 316 stainless steel and in pressure rating 16MPa or 42MPa.

**Hand-held communicator:**

(Model FXW, refer to Data Sheet No. EDS 8-47)

**Communication module:** (standard for model FKC)

When using this module for model FHC, remote setting function becomes available.

Remark: When the communication module is connected, the operation mode of external zero/span adjustable screw is changed to zero adjustment.

# CODE SYMBOLS

1 2 3 4 5 6 7 8 9 10 11 12 13 14 15																																									
							3								Description																										
FHC															<b>Type</b> 4 to 20mA, Output type 4 to 20mA with digital signal, Output type																										
FKC															<b>Connections</b> <table border="1"> <thead> <tr> <th>Process connection</th> <th>Oval flange screw</th> <th>Conduit connection</th> </tr> </thead> <tbody> <tr> <td>Rc1/4</td> <td>7/16-20UNF</td> <td>G 1/2</td> </tr> <tr> <td>1/4-18NPT</td> <td>7/16-20UNF</td> <td>1/2-14NPT</td> </tr> <tr> <td>1/4-18NPT</td> <td>M10</td> <td>Pg 13.5</td> </tr> <tr> <td>1/4-18NPT</td> <td>M10</td> <td>M20x1.5</td> </tr> <tr> <td>1/4-18NPT</td> <td>7/16-20UNF</td> <td>Pg 13.5</td> </tr> </tbody> </table>		Process connection	Oval flange screw	Conduit connection	Rc1/4	7/16-20UNF	G 1/2	1/4-18NPT	7/16-20UNF	1/2-14NPT	1/4-18NPT	M10	Pg 13.5	1/4-18NPT	M10	M20x1.5	1/4-18NPT	7/16-20UNF	Pg 13.5							
Process connection	Oval flange screw	Conduit connection																																							
Rc1/4	7/16-20UNF	G 1/2																																							
1/4-18NPT	7/16-20UNF	1/2-14NPT																																							
1/4-18NPT	M10	Pg 13.5																																							
1/4-18NPT	M10	M20x1.5																																							
1/4-18NPT	7/16-20UNF	Pg 13.5																																							
S															<b>Span and materials</b> <table border="1"> <thead> <tr> <th>Static pressure [MPa] {bar}</th> <th>Span limit (*1) FHC/FKC [kPa] (m bar)</th> <th>Process cover</th> <th>Diaphragm</th> <th>Wated cell body</th> </tr> </thead> <tbody> <tr> <td rowspan="2">33C</td> <td rowspan="2">-0.1 to 16 (-1 to +160)</td> <td rowspan="2">316 stainless steel</td> <td rowspan="2">316Lstainless steel (*1)</td> <td rowspan="2">316 stainless steel</td> </tr> <tr> <td>3.2/0.32...32/32 (32/3.2...320/320)</td> </tr> <tr> <td>35C</td> <td></td> <td></td> <td></td> <td></td> </tr> <tr> <td></td><td></td><td></td><td></td><td></td> <td>13/1.3...130/130 (130/13...1300/1300)</td> <td></td><td></td><td></td> </tr> </tbody> </table>		Static pressure [MPa] {bar}	Span limit (*1) FHC/FKC [kPa] (m bar)	Process cover	Diaphragm	Wated cell body	33C	-0.1 to 16 (-1 to +160)	316 stainless steel	316Lstainless steel (*1)	316 stainless steel	3.2/0.32...32/32 (32/3.2...320/320)	35C										13/1.3...130/130 (130/13...1300/1300)			
Static pressure [MPa] {bar}	Span limit (*1) FHC/FKC [kPa] (m bar)	Process cover	Diaphragm	Wated cell body																																					
33C	-0.1 to 16 (-1 to +160)	316 stainless steel	316Lstainless steel (*1)	316 stainless steel																																					
					3.2/0.32...32/32 (32/3.2...320/320)																																				
35C																																									
					13/1.3...130/130 (130/13...1300/1300)																																				

Notes: \* (1) The diaphragm face is coated with gold and ceramic.

1	2	3	4	5	6	7	8	9	10	11	12	13	14	15
F	H	C					3							
F	K	C					3							

															Description		
															<b>Indicator and arrester</b>		
A															Indicator	Arrester	
B															None	None	
C															Analog, 0 to 100% linear scale	None	
D															Analog, 0 to 100% sq. root scale	None	
E															Analog, custom scale	None	
F															Analog, double scale	None (*4)	
G															None	Yes	
H															Analog, 0 to 100% linear scale	Yes	
I															Analog, 0 to 100% sq. root scale	Yes	
J															Analog, custom scale	Yes	
K															Analog, double scale	Yes(*4)	
L															Digital, 0 to 100%	None	
M															Digital, custom scale	None (Model FKC only) (*5)	
N															Digital, 0 to 100% square root	None	
O															Digital, 0 to 100%	Yes	
P															Digital, custom scale	Yes (Model FKC only) (*5)	
Q															Digital, 0 to 100% square root	Yes	
															<b>Approvals for hazardous locations (Approval pending)</b>		
A															None (for ordinary locations)		
B															JIS, Flameproof (Conduit seal)		
C															JIS, Flameproof (Cable gland seal)		
D															FM, Flameproof (or explosionproof)		
E															CSA, Flameproof (or explosionproof)		
M															BASEEFA, Flameproof (Conduit seal)		
N															BASEEFA, Flameproof (Cable gland seal) (Conduit connection G 1/2 only)		
G															JIS, Intrinsic safety		
H															FM, Intrinsic safety and Nonincendive		
J															CSA, Intrinsic safety and Nonincendive		
K															CENELEC, Intrinsic safety		
P															CENELEC, Intrinsic safety and BASEEFA, Type N		
R															SAA Flameproof (Conduit seal)(Available for 4th digit code "S,T,W")		
T															SAA Intrinsic safety (Available for 4th digit code "S,T,W")		
Q															SAA Type-N (non-sparking)(Available for 4th digit code "S,T,W")		
															<b>Side vent/drain and mounting bracket</b>		
															Side vent/drain	Mounting bracket	
A															None	None	
B															None	Yes, carbon steel	
C															None	Yes, stainless steel	
D															Yes	None	
E															Yes	Yes, carbon steel	
F															Yes	Yes, stainless steel	
															<b>Stainless steel parts</b>		
															Stainless steel tag plate	Stainless steel elec. housing	Coating of cell
Y															None	None	None
B															Yes	None	None
C															None	Yes	None
E															Yes	Yes	None
M															None	None	Yes
N															Yes	None	Yes
P															None	Yes	Yes
Q															Yes	Yes	Yes
															<b>Special applications and fill fluid</b>		
															Treatment	Fill fluid	
Y															None (standard)	Silicone oil	
W															None (standard)	Fluorinated oil	
G															Degreasing	Silicone oil	
A															Oxygen service	Fluorinated oil	
N															NACE specification	Silicon oil	
															<b>Sensor O-ring</b>		
A															Viton		
B															Teflon		
															<b>Bolt/nut</b>		
A															Cr-Mo alloy hexagon socket head cap screw/carbon steel nut		
B															Cr-Mo alloy hexagon bolt/nut		
C															NACE bolt/nut (ASTMA 193 B7M/A 194 2HM)	} (*3)	
D															NACE bolt/nut (ASTMA 193 B7M/A 194 2HM)		
E															304 stainless steel/304 stainless steel (*6)		

Notes: \* (3) Static pressure should be -0.1 to +10MPa[-1 to 100bar]  
 (4) The scale is selectable "JIS and SI unit" or "Linear and sq. root" or "Linear and sq. root by 10"  
 (5) In case of FKC, specified the output mode linear or sq. root. Unless specified the output mode is linear. In case of 9th digit code "P", "S" with FKC, specified the output indication. Unless specified, the indication is output mode.  
 (6) In case of tropical use, select a stainless bolts and nuts.

# OUTLINE DIAGRAM (Unit:mm)

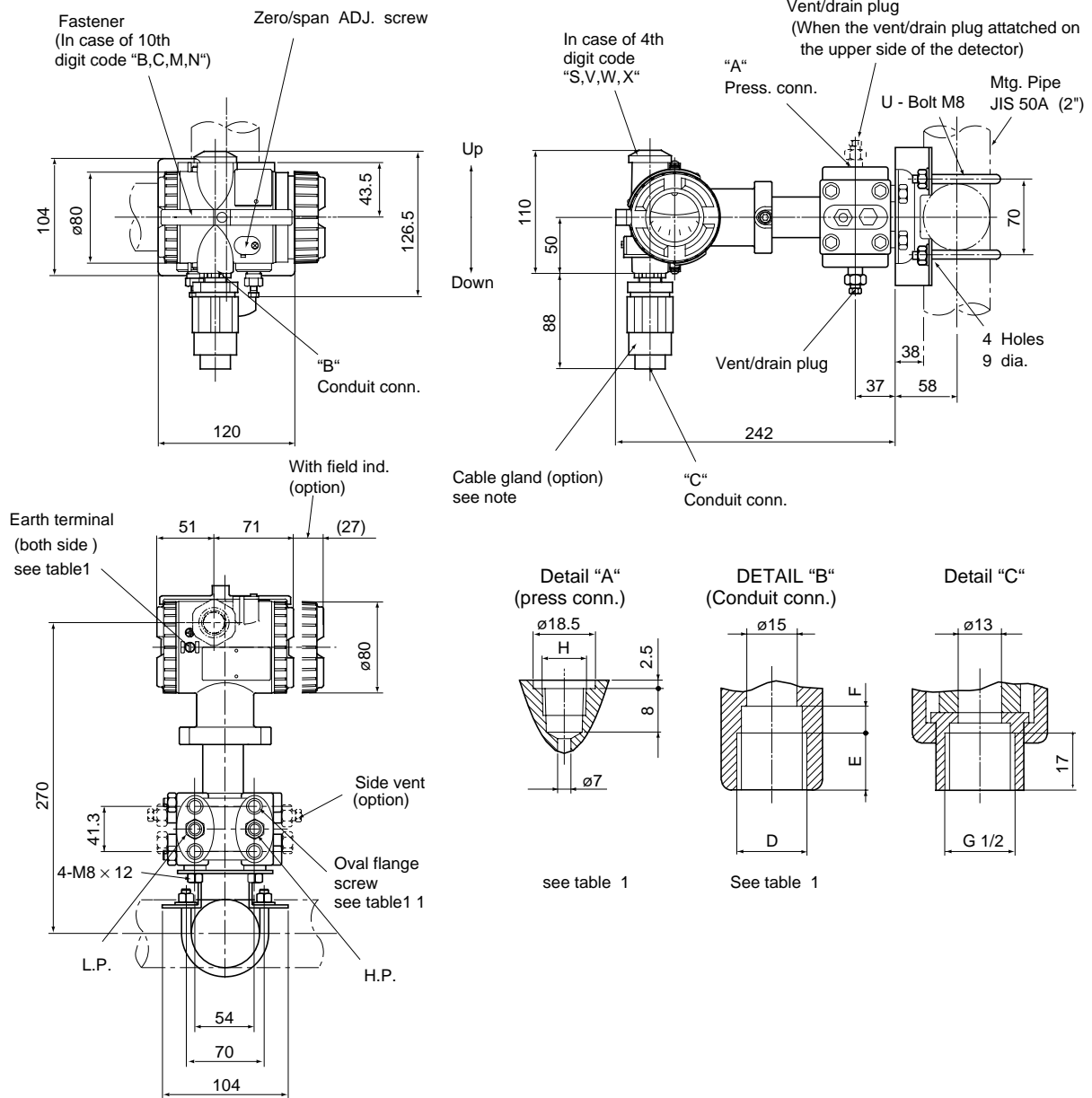

4th of Code symbols	Conduit conn.			Press. conn.	Oval flange screw	Earth terminal
	D	E	F			
S	G1/2	17	8	Rc1/4	7/16-20UNF screw depth 13	M4
T	1/2-14NPT	16	5	1/4-18NPT	7/16-20UNF screw depth 13	No. 8-32UNC
V	Pg13.5	8	4.5	1/4-18NPT	M10 or M12 screw depth 13	M4
W	M20x1.5	16	5	1/4-18NPT	M10 or M12 screw depth 13	M4
X	Pg13.5	8	4.5	1/4-18NPT	7/16-20UNF screw depth 13	M4

Table 1

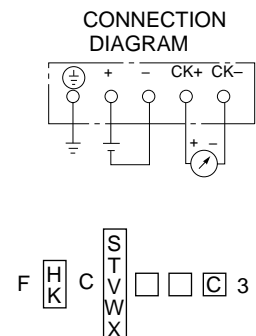

Note \*: Cable gland is supplied in case of flameproof packing type.  
ø11 cable is suitable.

The product conforms to the requirements of the Electromagnetic compatibility Directive 89/336/EEC as detailed within the technical construction file number TN510412. The applicable standards used to demonstrate compliance are :-

**EMI (Emission) EN50081-1 : 1992**

Test item	Frequency range	Basic standard
Applicable Electro-magnetic Radiation Disturbance	30-1000MHz	EN55022 Class B

**EMS (Immunity) EN50082-1 : 1992**

No.	Test item	Test specification	Basic standard	Performance criteria
1	Electrostatic discharge	8kV (Air)	IEC 801-2:1984	B
2	Radio-frequency electromagnetic field.	27-500MHz 3V/m (Unmodulated)	IEC 801-3:1984	A
3	Fast transients common mode	0.5kV, 5/50 (Tr/Th) ns 5kHz Rep.	IEC 801-4:1988	B

"LVD - The transmitter is not covered by the requirements of the LVD standard."

## Fuji Electric Co.,Ltd.

### Head office

11-2 Osaki 1-chome, Shinagawa-ku, Tokyo, 141-0032 Japan  
Phone: 81-3-5435-7111  
<http://www.fujielectric.co.jp/eng/sg/KEISOKU/welcome.htm>

## Fuji Electric Instruments Co.,Ltd.

### Sales Div.

#### International Sales Dept.

No.1, Fuji-machi, Hino-city, Tokyo, 191-8502 Japan  
Phone: 81-42-585-6201, 6202  
Fax: 81-42-585-6187, 6189