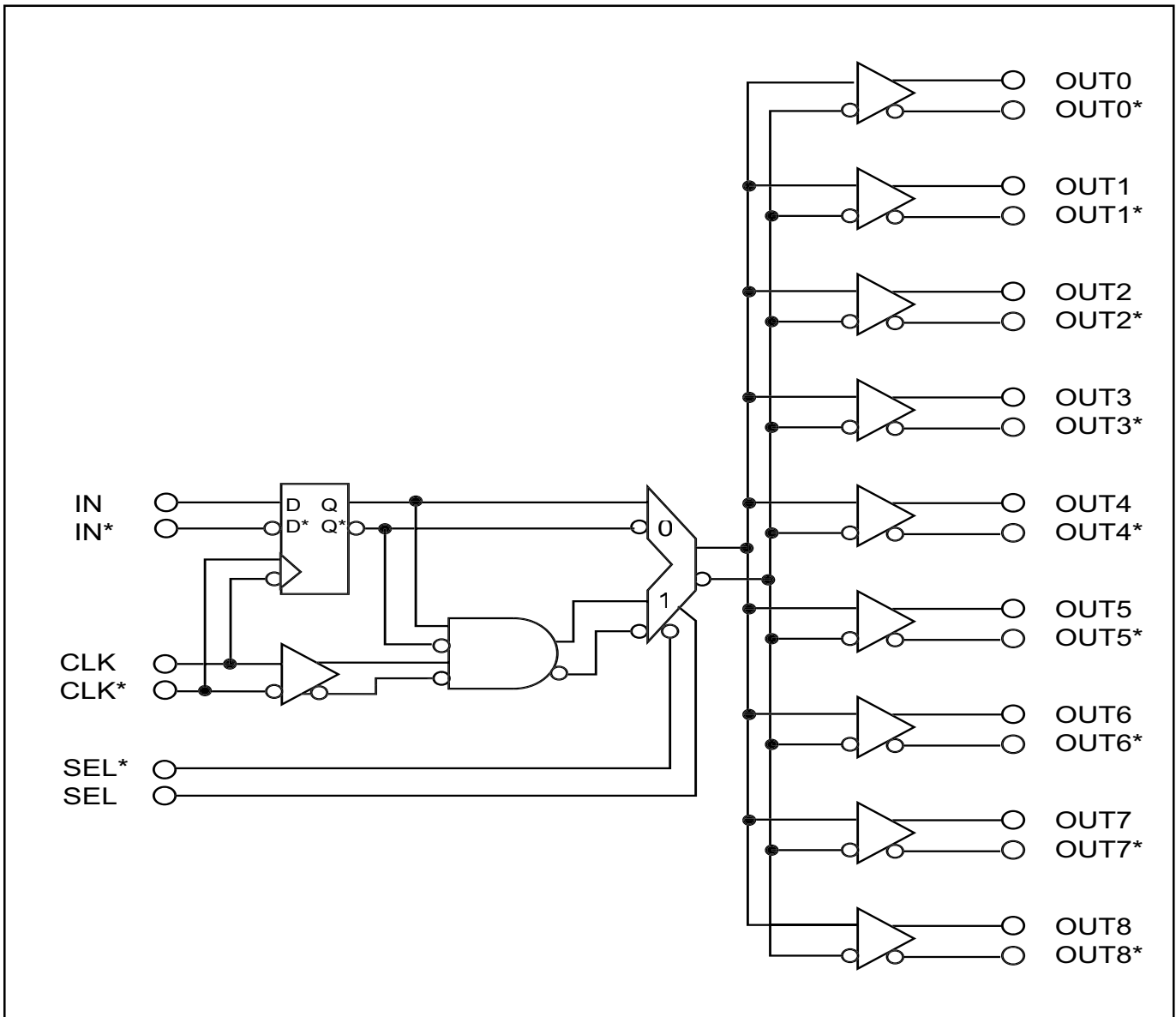

SK19XX Family Functional Block Diagram

SK19XX Family Product Selection Guide

1:9 Signal Distribution
3 GHz
Synch / Asynch Operation

Logic Family

Product	Power Supply		Output Configuration				Output	Availability
	3.3V	5.2V	Open Emitter	50Ω Double Termination	50Ω Source Termination	Internal Current Sink (Double Termination)		
SK1900	●	●	●				ECL / PECL	Now
SK1901		●	●				Double Swing / TTL	Now
SK1902	●	●		●			ECL / PECL	Now
SK1903	●	●				●	ECL / PECL	Now
SK1904	●	●			●		ECL / PECL	Now

Logic / Translation Family

Product	Translation	Output Configuration			Availability
		Open Emitter	50Ω Double Termination	50Ω Source Termination	
SK1925	Anything to PECL	●			Now
SK1926	Anything to ECL	●			Now
SK1927	Anything to PECL		●		Now
SK1928	Anything to ECL		●		Now
SK1929	Anything to PECL			●	Now
SK1930	Anything to ECL			●	Now

Open Collector Logic Family

Product	Output Configuration	Output Current	Availability
	Open Collector		
SK1999	●	12mA	Q2 2001

*SK19XX Family Package Information
5mm x 5mm TQFP*

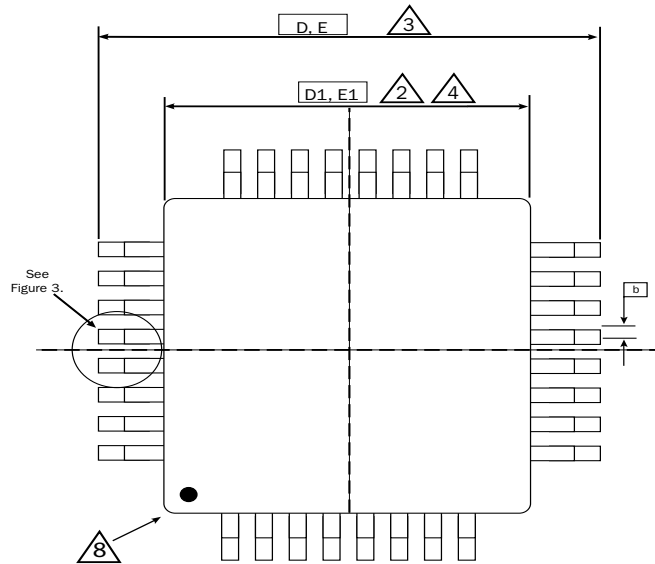

Top View

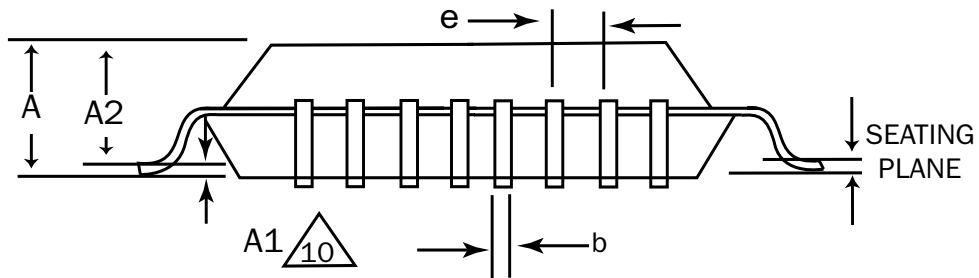

Side View

SK19XX Family Package Information (continued)

5mm x 5mm TQFP

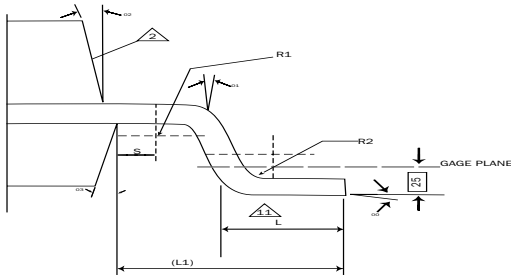

Figure 1.

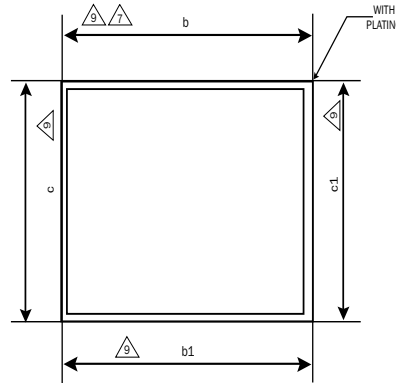

Figure 2.

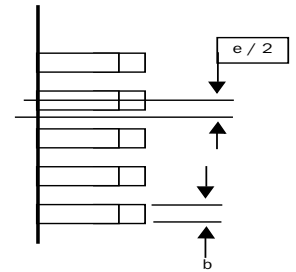

Figure 3.

- All dimensions and tolerancing conforms to ANSI Y14.5M-1982.
- The top package body size may be smaller than the bottom package body size by as much as 0.15 mm.
- To be determined at seating plane.
- Dimensions D1 and E1 do not include mold protrusion. Allowable protrusion is 0.25 mm per side. D1 and E1 are maximum plastic body size dimensions including mold mismatch.
- Details of Pin 1 identifier optional, but must be located within the zone indicated.
- All dimensions are in millimeters.
- Dimension b does not include Dambar protrusion. Allowable Dambar protrusion shall not cause the lead width to exceed the maximum b dimension by more than 0.08 mm. Dambar cannot be located on the lower radius or the foot. Minimum space between protrusion and an adjacent lead is 0.07 mm for 0.4 mm and 0.5 mm pitch packages.
- Exact shape of each corner is optional.
- These dimensions apply to the flat section of the lead between 0.10 mm and 0.25 mm from the lead tip.
- A1 is defined as the distance from the seating plane to the lowest point of the package body.

JEDEC Variation					
All Dimensions in Millimeters					
Symbol	MIN	NOM	MAX	Note	Comments
A	1.00	1.10	1.20		Package Stand Off Height
A1	0.05	0.10	0.15		Air Gap
A2	0.95	1.00	1.05		Package Body Thickness
D	7.00 BSC			3	
D1	5.00 BSC			4, 2	Package Body Length
E	7.00 BSC			3	
E1	5.00 BSC			4, 2	Package Body Width
N	32				Lead Count
e	0.50 BSC				Lead Pitch
b	0.17	0.22	0.27	7	Lead Thickness
b1	0.17	0.20	0.23		
R1	0.08	-	-		
R2	0.08	-	0.20		
00	0°	3.5°	7°		
01	0°	-	-		
02	11°	12°	13°		
03	11°	12°	13°		
S	0.20	-	-		
c	0.09	-	0.20		
c1	0.09	-	0.16		
L	0.45	0.60	0.75		
L1	1.00 REF				
aaa	0.20				
bbb	0.20				
ccc	0.08				
ddd	0.08				

Absolute Maximum Ratings*

Symbol	Parameter	Value	Unit
V_{EE}	Power Supply ($V_{CC} = 0V$)	-6.0 to 0	V
V_{CC}	Power Supply ($V_{EE} = 0V$)	6.0 to 0	V
V_I	Input Voltage ($V_{CC} = 0V$, V_I not more negative than V_{EE})	-6.0 to 0	V
V_I	Input Voltage ($V_E = 0V$, V_I not more positive than V_{CC})	6.0 to 0	V
I_{OUT}	Output Current Continuous Surge	50 100	mA mA
T_A	Operating Temperature Range	0 to +70	°C
T_{stg}	Storage Temperature	-65 to +150	°C
T_{sol}	Solder Temperature (<2 to 3 seconds: 245°C desired)	265	°C

* Maximum Ratings are those values beyond which damage to the device may occur.

Description

The SK1900 is an extremely fast, stable, and accurate low skew 1:9 clock / signal distributor featuring a synchronous enable, which allows the outputs to be turned off and on without the risk of an unpredictable output pulse. The D - flip-flop is triggered on the falling edge of the clock.

The SK1900 uses standard open emitter ECL outputs optimized for:

- General purpose ECL compatible applications
- Multiple destination applications (daisy chain).

Features

- 1:9 Clock/Data Driver
- 3 GHz Fmax
- 3.3V / 5.2V Compatible

Functional Block Diagram

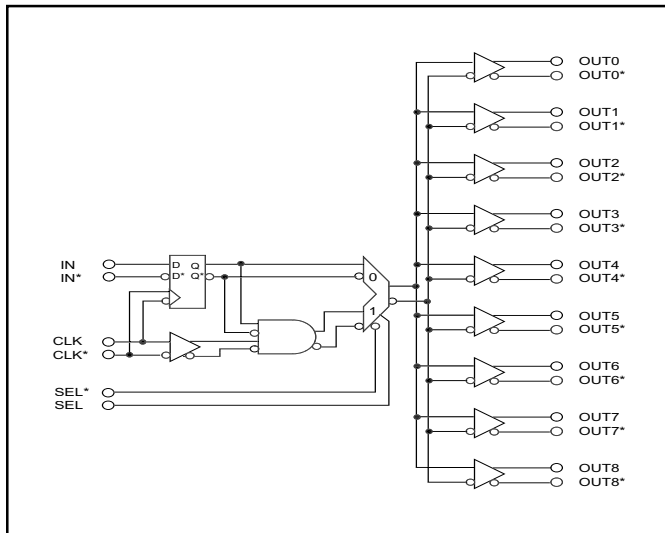

Package Information

32 pin, 5 mm x 5 mm
TQFP Package



Output Options

Open Emitter

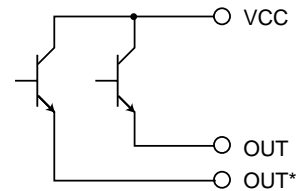

Output Swing

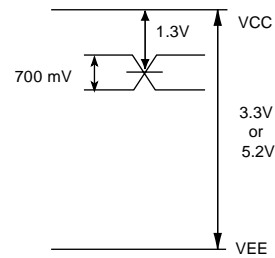

Pin Description

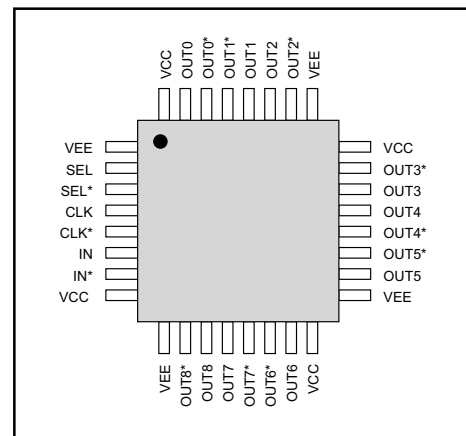

DC Characteristics

Parameter	Symbol	Min	Typ	Max	Units
Inputs					
Input High	V _{IH}	V _{EE} + 2.0		V _{CC}	V
Input Low	V _{IL}	V _{EE}		V _{CC} - .2	V
(IN - IN*, CLK - CLK*, SEL - SEL*) Differential Input Voltage (Note 1)	Input - Input*	.2		4.3	V
Timing Inputs (CLK / CLK*) Input High Current	I _{IH}	+1		+25	μA
Input Low Current	I _{IL}	-1		+1	μA
Functional Inputs (IN / IN*, SEL / SEL*) Input Current	I _{IH} , I _{IL}	-420		+250	μA
Outputs					
Digital Output Voltage Output Common Mode Range	OUT - OUT* (OUT + OUT*) / 2	600 V _{CC} - 1.5	700 V _{CC} - 1.3	V _{CC} - 1.1	mV V
Power Supply					
Power Supply Current	I _{EE}		135	170	mA
Power Supply Voltage	V _{CC} - V _{EE}	3.0		5.5	V

Test Conditions: Outputs terminated with 50Ω to V_{CC} – 2V.

Note 1: Production tested to a maximum V_{diff} = 2.0V.

AC Characteristics

Parameter	Symbol	Min	Typ	Max	Units
High Performance Option					
Propagation Delay CLK to OUT (SEL = 0)	T _{pd}	490	590	690	ps
CLK to OUT (SEL = 1)	T _{pd}	340	440	540	ps
SEL to OUT	T _{pd}	330	430	530	ps
Channel to Channel Skew				<20	ps
Maximum Operating Frequency (Note 1)	F _{max}	3.0			GHz
Minimum Pulse Width (Note 1)	PW min	160			ps
IN to CLK (Note 1) Set Up Time	T _{su}	100			ps
Hold Time	T _h	100			ps
Output Rise and Fall Times (20% / 80%)	T _r / T _f		125	150	ps
Temperature Coefficient	ΔT _{pd} / ΔT		<1		ps / °C

AC Test Conditions: Outputs terminated with 50Ω to V_{CC} – 2V.

Note 1: Guaranteed by characterization. Not production tested.

Description

The SK1901 is an extremely fast, stable, and accurate low skew 1:9 clock / signal distributor featuring a synchronous enable, which allows the outputs to be turned off and on without the risk of an unpredictable output pulse. The D - flip-flop is triggered on the falling edge of the clock.

The SK1901 uses open emitter outputs with a double amplitude swing suitable for the following applications:

- TTL compatible destinations
- Double termination situations that require a full swing at the destination
- Long cables

Features

- 1:9 Clock/Data Driver
- 2 GHz Fmax
- 4.5V / 5.2V Compatible

Functional Block Diagram

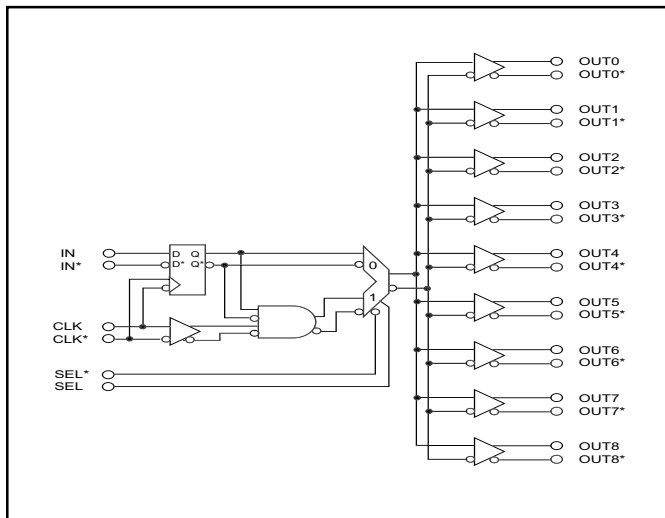

Output Options

Open Emitter

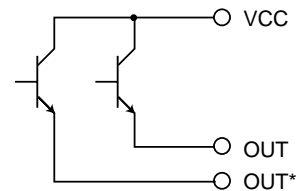

Output Swing

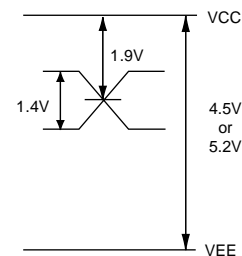

Package Information

32 pin, 5 mm x 5 mm
TQFP Package



Pin Description

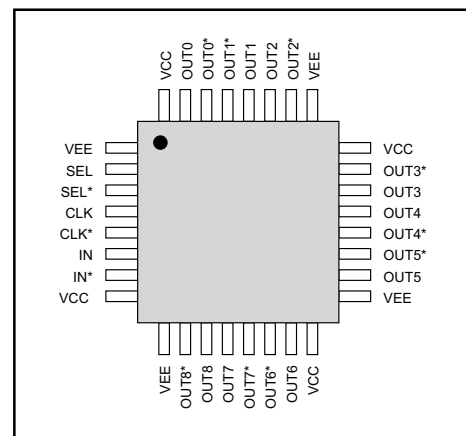

DC Characteristics

Parameter	Symbol	Min	Typ	Max	Units
Inputs					
Input High	V _{IH}	V _{EE} + 2.0		V _{CC}	V
Input Low	V _{IL}	V _{EE}		V _{CC} - .2	V
(IN - IN*, CLK - CLK*, SEL - SEL*) Differential Input Voltage	Input - Input*	.2		4.3	V
Timing Inputs (CLK / CLK*) Input High Current	I _{IH}	+1		+25	μA
Input Low Current	I _{IL}	-1		+1	μA
Functional Inputs (IN / IN*, SEL / SEL*) Input Current	I _{IH} , I _{IL}	-420		+250	μA
Outputs					
Digital Output Voltage	OUT - OUT*	1.2	1.4		V
Output Common Mode Range	(OUT + OUT*) / 2	V _{CC} - 2.1	V _{CC} - 1.9	V _{CC} - 1.7	V
Power Supply					
Power Supply Current	I _{EE}		135	170	mA
Power Supply Voltage	V _{CC} - V _{EE}	4.2		5.5	V

Test Conditions: Outputs terminated with 50Ω to V_{CC} – 3V.

AC Characteristics

Parameter	Symbol	Min	Typ	Max	Units
High Performance Option					
Propagation Delay CLK to OUT (SEL = 0)	T _{pd}	490	590	690	ps
CLK to OUT (SEL = 1)	T _{pd}	340	440	540	ps
SEL to OUT	T _{pd}	330	430	530	ps
Channel to Channel Skew				<20	ps
Maximum Operating Frequency (Note 1)	F _{max}	2.0			GHz
Minimum Pulse Width (Note 1)	PW min	250			ps
IN to CLK (Note 1) Set Up Time	T _{su}	100			ps
Hold Time	T _h	100			ps
Output Rise and Fall Times (20% / 80%)	T _r / T _f		200	250	ps
Temperature Coefficient	ΔT _{pd} / ΔT		<1		ps / °C

AC Test Conditions: Outputs terminated with 50Ω to V_{CC} – 3V.

Note 1: Guaranteed by characterization. Not production tested.

Description

The SK1902 is an extremely fast, stable, and accurate low skew 1:9 clock / signal distributor featuring a synchronous enable, which allows the outputs to be turned off and on without the risk of an unpredictable output pulse. The D - flip-flop is triggered on the falling edge of the clock.

The SK1902 uses 50Ω outputs with source /sink capability, and is optimized for applications that require:

- Point to point, double terminated, timing critical lines

Features

- 1:9 Clock/Data Driver
- 3 GHz Fmax
- 3.3V / 5.2V Compatible

Output Options

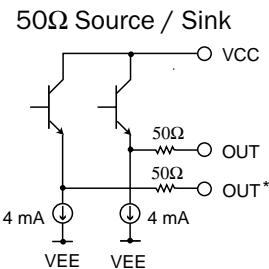

Output Swing

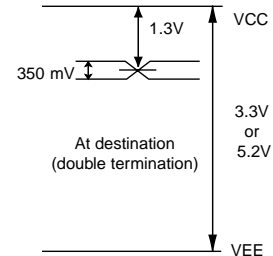

Functional Block Diagram

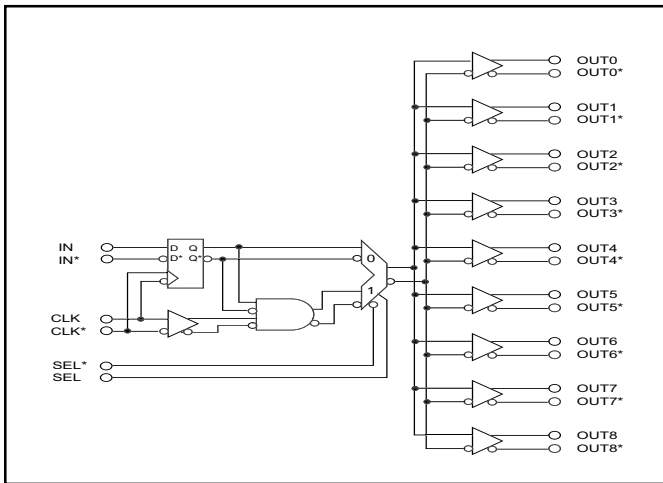

Pin Description

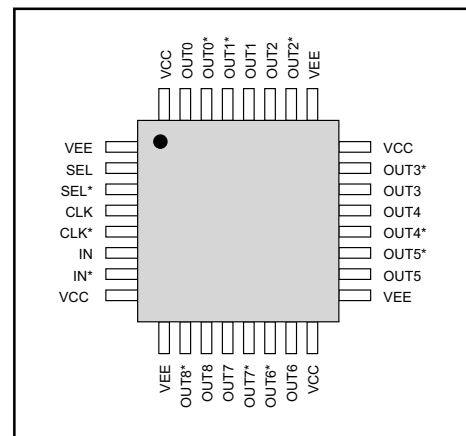

Package Information

32 pin, 5 mm x 5 mm
TQFP Package



DC Characteristics

Parameter	Symbol	Min	Typ	Max	Units
Inputs					
Input High	V _{IH}	VEE + 2.0		VCC	V
Input Low	V _{IL}	VEE		VCC - .2	V
(IN - IN*, CLK - CLK*, SEL - SEL*) Differential Input Voltage	Input - Input*	.2		4.3	V
Timing Inputs (CLK / CLK*)					
Input High Current	I _{IH}	+1		+25	μA
Input Low Current	I _{IL}	-1		+1	μA
Functional Inputs (IN / IN*, SEL / SEL*) Input Current	I _{IH} , I _{IL}	-420		+250	μA
Outputs					
Digital Output Voltage	OUT - OUT*	600	700		mV
Output Common Mode Range	(OUT + OUT*) / 2	VCC - 1.5	VCC - 1.3	VCC - 1.1	V
Internal Current Source	ISINK	TBD	5	TBD	mA
Output Impedance	ROUT	40	45	50	Ω
Power Supply					
Power Supply Current	I _{EE}		210	265	mA
Power Supply Voltage	VCC - VEE	3.0		5.5	V

Test Conditions: Outputs unterminated.

AC Characteristics

Parameter	Symbol	Min	Typ	Max	Units
High Performance Option					
Propagation Delay					
CLK to OUT (SEL = 0)	T _{pd}	490	590	690	ps
CLK to OUT (SEL = 1)	T _{pd}	340	440	540	ps
SEL to OUT	T _{pd}	330	430	530	ps
Channel to Channel Skew				<20	ps
Maximum Operating Frequency (Note 1)	F _{max}	3.0			GHz
Minimum Pulse Width (Note 1)	PW min	160			ps
IN to CLK (Note 1)					
Set Up Time	T _{su}	100			ps
Hold Time	T _h	100			ps
Output Rise and Fall Times (20% / 80%)	T _r / T _f		125	150	ps
Temperature Coefficient	ΔT _{pd} / ΔT		<1		ps / °C

AC Test Conditions: Outputs are terminated with 50 Ω to VCC - 2V.

Note 1: Guaranteed by characterization. Not production tested.

Description

The SK1903 is an extremely fast, stable, and accurate low skew 1:9 clock / signal distributor featuring a synchronous enable, which allows the outputs to be turned off and on without the risk of an unpredictable output pulse. The D - flip-flop is triggered on the falling edge of the clock.

The SK1903 outputs are open emitter with an internal current source, optimized for applications that are:

- Point to point, double terminated, timing critical lines
- Non-50Ω transmission lines

Features

- 1:9 Clock/Data Driver
- 3 GHz Fmax
- 3.3V / 5.2V Compatible

Functional Block Diagram

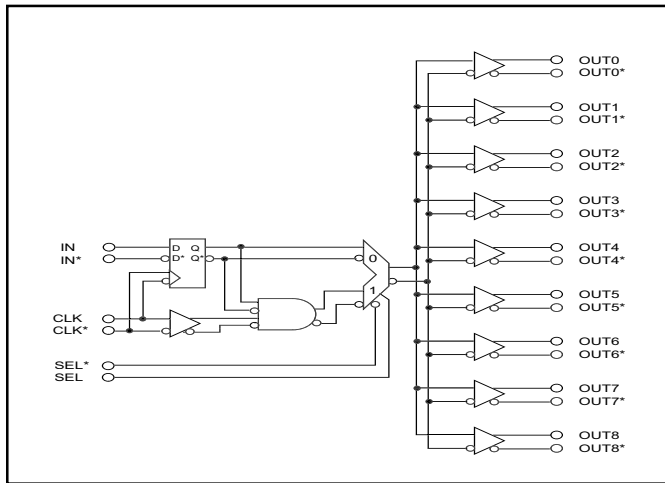

Package Information

32 pin, 5 mm x 5 mm
TQFP Package

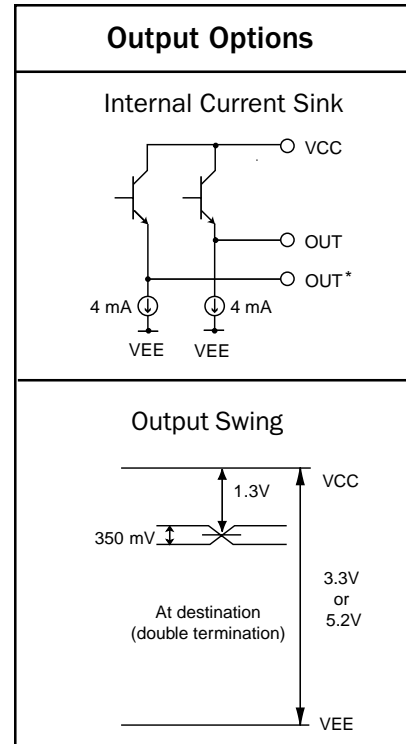

Pin Description

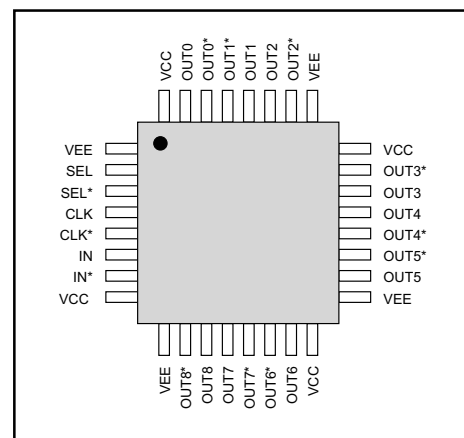

DC Characteristics

Parameter	Symbol	Min	Typ	Max	Units
Inputs					
Input High	V _{IH}	V _{EE} + 2.0		V _{CC}	V
Input Low	V _{IL}	V _{EE}		V _{CC} - .2	V
(IN - IN*, CLK - CLK*, SEL - SEL*) Differential Input Voltage	Input - Input*	.2		4.3	V
Timing Inputs (CLK / CLK*)					
Input High Current	I _{IH}	+1		+25	μA
Input Low Current	I _{IL}	-1		+1	μA
Functional Inputs (IN / IN*, SEL / SEL*)					
Input Current	I _{IH} , I _{IL}	-420		+250	μA
Outputs					
Digital Output Voltage	OUT - OUT*	600	700		mV
Output Common Mode Range	(OUT + OUT*) / 2	V _{CC} - 1.5	V _{CC} - 1.3	V _{CC} - 1.1	V
Internal Current Source	I _{SINK}	TBD	5	TBD	mA
Power Supply					
Power Supply Current	I _{EE}		210	265	mA
Power Supply Voltage	V _{CC} - V _{EE}	3.0		5.5	V

Test Conditions: Outputs Unterminated.

AC Characteristics

Parameter	Symbol	Min	Typ	Max	Units
High Performance Option					
Propagation Delay					
CLK to OUT (SEL = 0)	T _{pd}	490	590	690	ps
CLK to OUT (SEL = 1)	T _{pd}	340	440	540	ps
SEL to OUT	T _{pd}	330	430	530	ps
Channel to Channel Skew				<20	ps
Maximum Operating Frequency (Note 1)	F _{max}	3.0			GHz
Minimum Pulse Width (Note 1)	PW min	160			ps
IN to CLK (Note 1)					
Set Up Time	T _{su}	100			ps
Hold Time	T _h	100			ps
Output Rise and Fall Times (20% / 80%)	T _r / T _f		125	150	ps
Temperature Coefficient	ΔT _{pd} / ΔT		<1		ps / °C

AC Test Conditions: Outputs are terminated with 50 Ω to V_{CC} - 2V.

Note 1: Guaranteed by characterization. Not production tested.

Description

The SK1904 is an extremely fast, stable, and accurate low skew 1:9 clock / signal distributor featuring a synchronous enable, which allows the outputs to be turned off and on without the risk of an unpredictable output pulse. The D - flip-flop is triggered on the falling edge of the clock.

The SK1904 outputs are 50Ω with source and sink capability, optimized for:

- Point to point, series terminated, timing critical lines

Features

- 1:9 Clock/Data Driver
- 3 GHz Fmax
- 3.3V / 5.2V Compatible

Functional Block Diagram

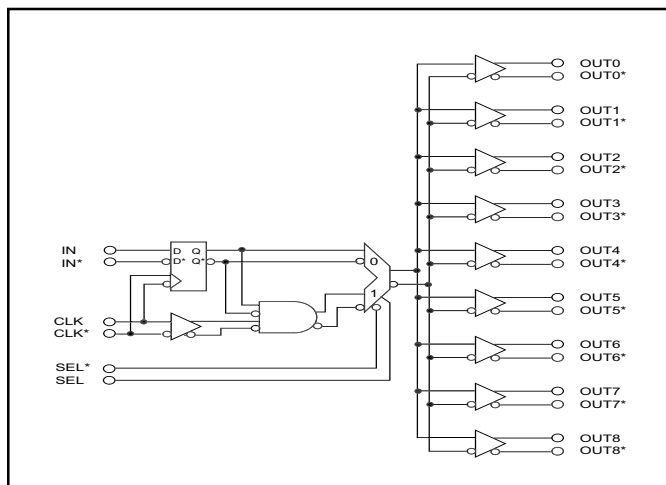

Package Information

32 pin, 5 mm x 5 mm
TQFP Package

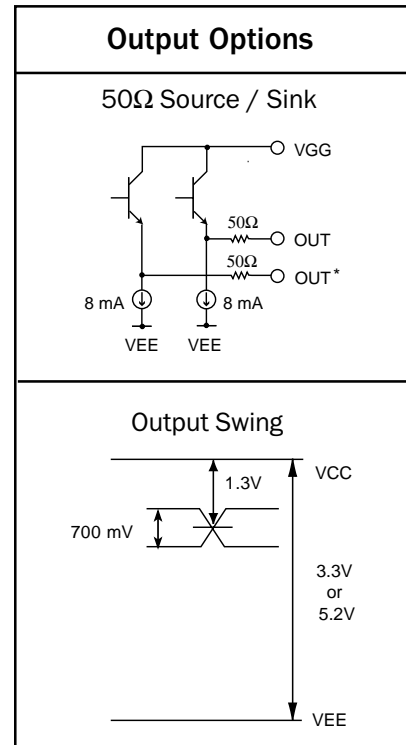

Pin Description

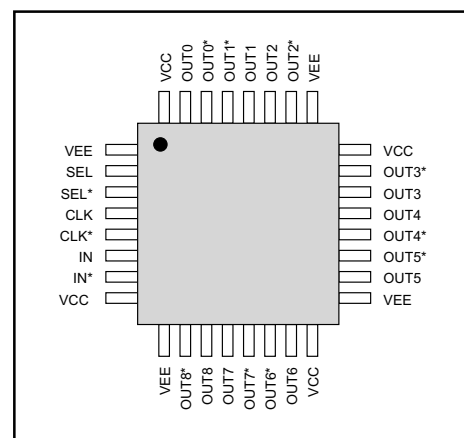

DC Characteristics

Parameter	Symbol	Min	Typ	Max	Units
Inputs					
Input High	V _{IH}	V _{EE} + 2.0		V _{CC}	V
Input Low	V _{IL}	V _{EE}		V _{CC} - .2	V
(IN - IN*, CLK - CLK*, SEL - SEL*) Differential Input Voltage	Input - Input*	.2		4.3	V
Timing Inputs (CLK / CLK*) Input High Current	I _{IH}	+1		+25	μA
Input Low Current	I _{IL}	-1		+1	μA
Functional Inputs (IN / IN*, SEL / SEL*) Input Current	I _{IH} , I _{IL}	-420		+250	μA
Outputs					
Digital Output Voltage	OUT - OUT*	600	700		mV
Output Common Mode Range	(OUT + OUT*) / 2	V _{CC} - 1.5	V _{CC} - 1.3	V _{CC} - 1.1	V
Internal Current Source	I _{SINK}	6.5	8	10	mA
Output Impedance	R _{OUT}	40	45	50	Ω
Power Supply					
Power Supply Current	I _{EE}		280	353	mA
Power Supply Voltage	V _{CC} - V _{EE}	3.0		5.5	V

Test Conditions: Outputs unterminated.

AC Characteristics

Parameter	Symbol	Min	Typ	Max	Units
High Performance Option					
Propagation Delay CLK to OUT (SEL = 0)	T _{pd}	490	590	690	ps
CLK to OUT (SEL = 1)	T _{pd}	340	440	540	ps
SEL to OUT	T _{pd}	330	430	530	ps
Channel to Channel Skew				<20	ps
Maximum Operating Frequency (Note 1)	F _{max}	3.0			GHz
Minimum Pulse Width (Note 1)	PW min	160			ps
IN to CLK (Note 1) Set Up Time	T _{su}	100			ps
Hold Time	T _h	100			ps
Output Rise and Fall Times (20% / 80%)	T _r / T _f		125	150	ps
Temperature Coefficient	ΔT _{pd} / ΔT		<1		ps / °C

AC Test Conditions: Outputs are terminated with 50 Ω to V_{CC} - 2V.

Note 1: Guaranteed by characterization. Not production tested.

Description

The SK1925 is an extremely fast, stable, and accurate low skew 1:9 clock / signal distributor featuring a synchronous enable, which allows the outputs to be turned off and on without the risk of an unpredictable output pulse. It is also capable of receiving inputs of any technology or voltage level. The D - flip-flop is triggered on the falling edge of the clock.

The SK1925 has open emitter PECL outputs.

Target applications:

- High speed clock / data lines that require translation
- Multiple destination (daisy chain) applications

- 1:9 Clock/Data Driver
- 3 GHz Fmax
- Anything to PECL Translation

Functional Block Diagram

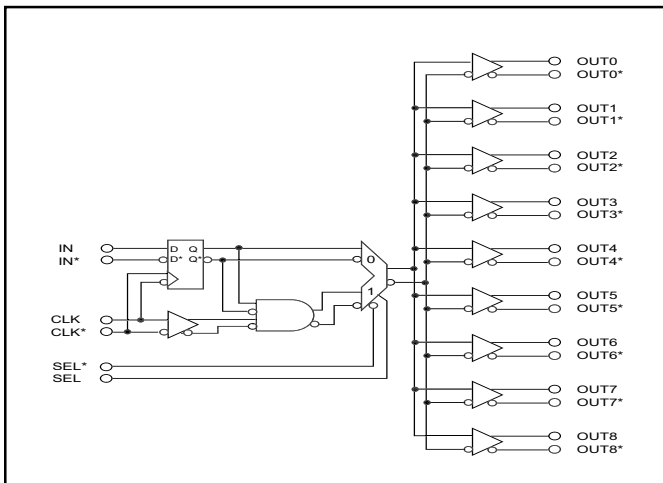

Package Information

32 pin, 5 mm x 5 mm
TQFP Package



Features

Output Options

Open Emitter

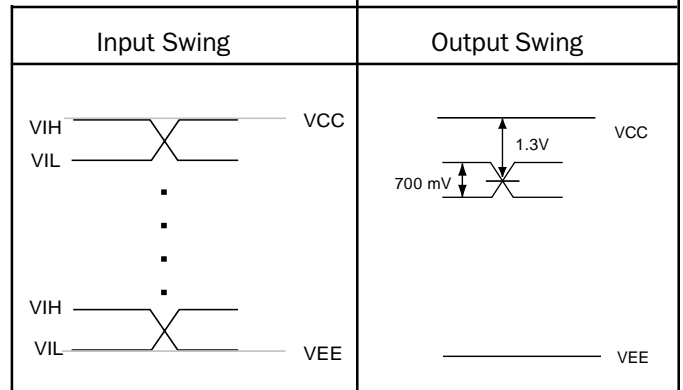
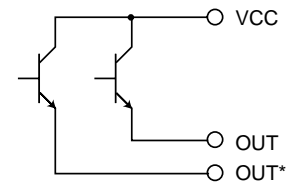

Pin Description

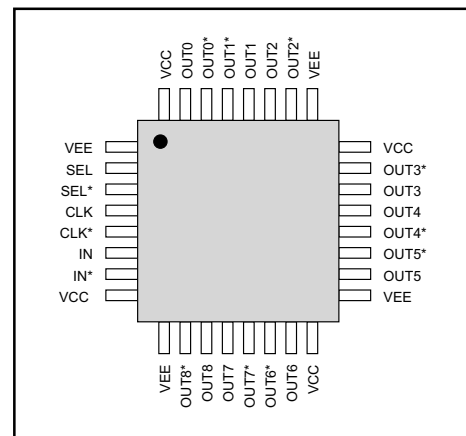

DC Characteristics

Parameter	Symbol	Min	Typ	Max	Units
Inputs					
Input High	V _{IH}	V _{EE} + 2.0		V _{CC}	V
Input Low	V _{IL}	V _{EE}		V _{CC} - 2	V
(IN - IN*, CLK - CLK*, SEL - SEL*) Differential Input Voltage	Input - Input*	.2		4.3	V
Timing Inputs (CLK / CLK*)					
Input High Current	I _{IH}	+1		+25	μA
Input Low Current	I _{IL}	-1		+1	μA
Functional Inputs (IN / IN*, SEL / SEL*) Input Current	I _{IH} , I _{IL}	-420		+250	μA
Outputs					
Digital Output Voltage	OUT - OUT*	600	700		mV
Output Common Mode Range	(OUT + OUT*) / 2	V _{CC} - 1.5	V _{CC} - 1.3	V _{CC} - 1.1	V
Power Supply					
Power Supply Current	I _{EE}		135	170	mA
Positive Supply Voltage	V _{CC}	3.0	3.3	3.6	V
Negative Supply Voltage	V _{EE}	-3.6	-3.3	-3.0	V

Test Conditions: Outputs terminated with 50Ω to V_{CC} - 2V.

AC Characteristics

Parameter	Symbol	Min	Typ	Max	Units
High Performance Option					
Propagation Delay					
CLK to OUT (SEL = 0)	T _{pd}	490	590	690	ps
CLK to OUT (SEL = 1)	T _{pd}	340	440	540	ps
SEL to OUT	T _{pd}	330	430	530	ps
Channel to Channel Skew				<20	ps
Maximum Operating Frequency (Note 1)	F _{max}	3.0			GHz
Minimum Pulse Width (Note 1)	PW min	160			ps
IN to CLK (Note 1)					
Set Up Time	T _{su}	100			ps
Hold Time	T _h	100			ps
Output Rise and Fall Times (20% / 80%)	T _r / T _f		125	150	ps
Temperature Coefficient	ΔT _{pd} / ΔT		<1		ps / °C

AC Test Conditions: Outputs are terminated with 50 Ω to V_{CC} - 2V.

Note 1: Guaranteed by characterization. Not production tested.

DC Characteristics

Parameter	Symbol	Min	Typ	Max	Units
Inputs					
Input High	V _{IH}	V _{EE} + 2.0		V _{CC}	V
Input Low	V _{IL}	V _{EE}		V _{CC} - 2	V
(IN - IN*, CLK - CLK*, SEL - SEL*) Differential Input Voltage	Input - Input*	.2		4.3	V
Timing Inputs (CLK / CLK*)					
Input High Current	I _{IH}	+1		+25	μA
Input Low Current	I _{IL}	-1		+1	μA
Functional Inputs (IN / IN*, SEL / SEL*) Input Current	I _{IH} , I _{IL}	-420		+250	μA
Outputs					
Digital Output Voltage	OUT - OUT*	600	700		mV
Output Common Mode Range	(OUT + OUT*) / 2	V _{GG} - 1.5	V _{GG} - 1.3	V _{GG} - 1.1	V
Power Supply					
Power Supply Current	I _{EE}		135	170	mA
	I _{CC}		45	52	mA
Positive Supply Voltage	V _{CC}	2.0	3.3	3.6	V
	V _{GG}	-1	0	2.0	V
Negative Supply Voltage	V _{EE}	-3.6	-3.3	-3.0	V
	V _{CC} - V _{GG}	0		3.6	V

Test Conditions: Outputs terminated with 50Ω to V_{GG} – 2V.

AC Characteristics

Parameter	Symbol	Min	Typ	Max	Units
High Performance Option					
Propagation Delay					
CLK to OUT (SEL = 0)	T _{pd}	490	590	690	ps
CLK to OUT (SEL = 1)	T _{pd}	340	440	540	ps
SEL to OUT	T _{pd}	330	430	530	ps
Channel to Channel Skew				<20	ps
Maximum Operating Frequency (Note 1)	F _{max}	3.0			GHz
Minimum Pulse Width (Note 1)	PW min	160			ps
IN to CLK (Note 1)					
Set Up Time	T _{su}	100			ps
Hold Time	T _h	100			ps
Output Rise and Fall Times (20% / 80%)	T _r / T _f		125	150	ps
Temperature Coefficient	ΔT _{pd} / ΔT		<1		ps / °C

AC Test Conditions: Outputs are terminated with 50 Ω to V_{GG} - 2V.

Note 1: Guaranteed by characterization. Not production tested.

Description

The SK1927 is an extremely fast, stable, and accurate low skew 1:9 clock / signal distributor featuring a synchronous enable, which allows the outputs to be turned off and on without the risk of an unpredictable output pulse. It is also capable of receiving inputs of any technology or voltage level. The D - flip-flop is triggered on the falling edge of the clock.

The SK1927 uses 50Ω outputs with source /sink capability, and is optimized for:

- High speed clock / data lines that require translation
- Point to point, double termination applications

Features

- 1:9 Clock/Data Driver
- 3 GHz Fmax
- Anything to PECL Translation

Functional Block Diagram

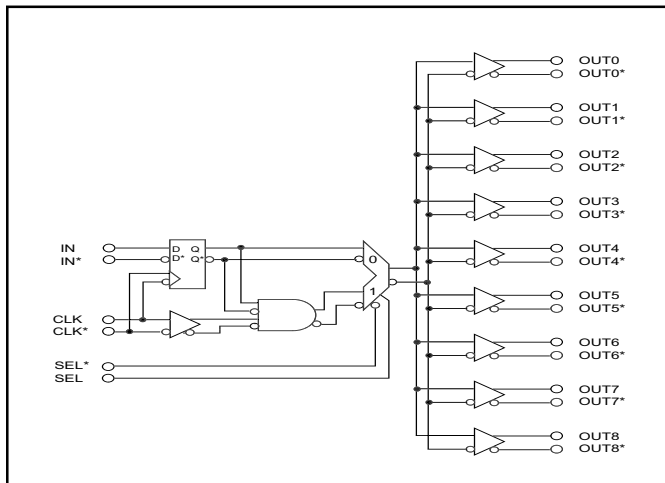

Package Information

32 pin, 5 mm x 5 mm
TQFP Package



Output Options

50Ω Source / Sink

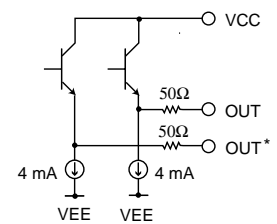

Input Swing

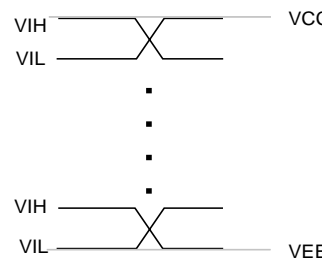

Output Swing

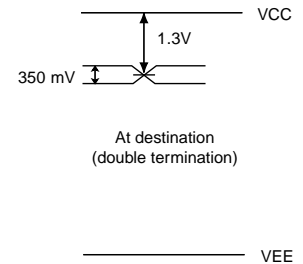

Pin Description

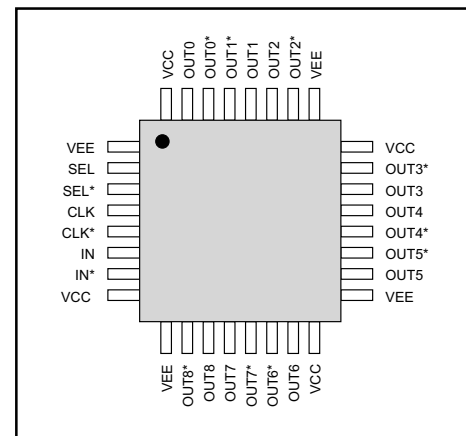

DC Characteristics

Parameter	Symbol	Min	Typ	Max	Units
Inputs					
Input High	V _{IH}	V _{EE} + 2.0		V _{CC}	V
Input Low	V _{IL}	V _{EE}		V _{CC} - .2	V
(IN - IN*, CLK - CLK*, SEL - SEL*) Differential Input Voltage	Input - Input*	.2		4.3	V
Timing Inputs (CLK / CLK*)					
Input High Current	I _{IH}	+1		+25	μA
Input Low Current	I _{IL}	-1		+1	μA
Functional Inputs (IN / IN*, SEL / SEL*) Input Current	I _{IH} , I _{IL}	-420		+250	μA
Outputs					
Digital Output Voltage	OUT - OUT*	600	700		mV
Output Common Mode Range	(OUT + OUT*) / 2	V _{CC} - 1.5	V _{CC} - 1.3	V _{CC} - 1.1	V
Internal Current Source	I _{SINK}	TBD	5	TBD	mA
Output Impedance	R _{OUT}	40	45	50	Ω
Power Supply					
Power Supply Current	I _{EE}		210	265	mA
Positive Supply Voltage	V _{CC}	3.0	3.3	3.6	V
Negative Supply Voltage	V _{EE}	-3.6	-3.3	-3.0	V

Test Conditions: Outputs unterminated.

AC Characteristics

Parameter	Symbol	Min	Typ	Max	Units
High Performance Option					
Propagation Delay					
CLK to OUT (SEL = 0)	T _{pd}	490	590	690	ps
CLK to OUT (SEL = 1)	T _{pd}	340	440	540	ps
SEL to OUT	T _{pd}	330	430	530	ps
Channel to Channel Skew				<20	ps
Maximum Operating Frequency (Note 1)	F _{max}	3.0			GHz
Minimum Pulse Width (Note 1)	PW min	160			ps
IN to CLK (Note 1)					
Set Up Time	T _{su}	100			ps
Hold Time	T _h	100			ps
Output Rise and Fall Times (20% / 80%)	T _r / T _f		125	150	ps
Temperature Coefficient	ΔT _{pd} / ΔT		<1		ps / °C

AC Test Conditions: Outputs are terminated with 50 Ω to V_{CC} - 2V.

Note 1: Guaranteed by characterization. Not production tested.

Description

The SK1928 is an extremely fast, stable, and accurate low skew 1:9 clock / signal distributor featuring a synchronous enable, which allows the outputs to be turned off and on without the risk of an unpredictable output pulse. It is also capable of receiving inputs of any technology and voltage level. The D - flip-flop is triggered on the falling edge of the clock.

The SK1928 has 50Ω outputs with source /sink capability, and is optimized for:

- High speed clock / data lines that require translation
- Point to point, double termination applications

Features

- 1:9 Clock/Data Driver
- 3 GHz Fmax
- Anything to ECL Translation

Functional Block Diagram

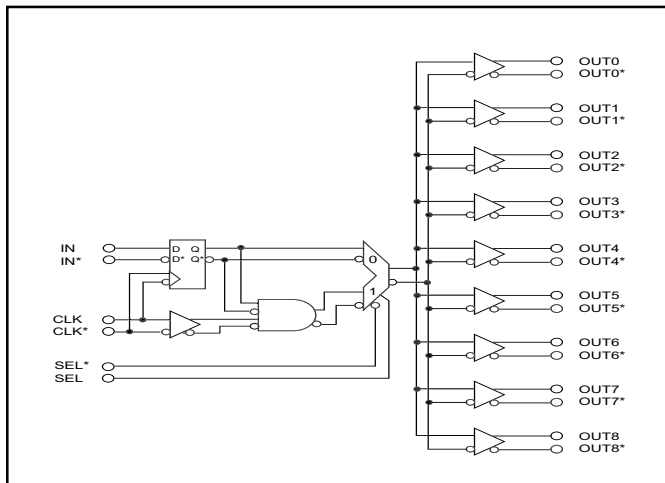

Package Information

32 pin, 5 mm x 5 mm
TQFP Package

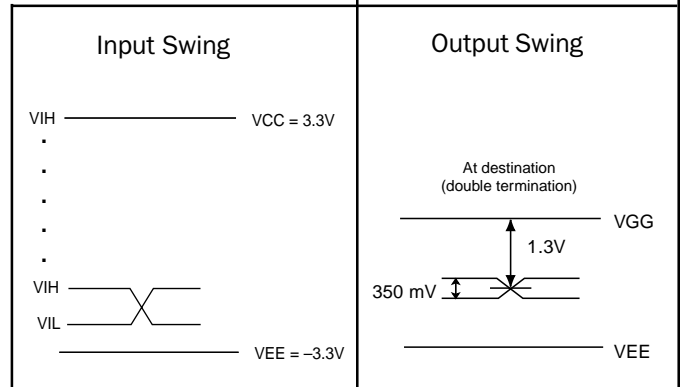
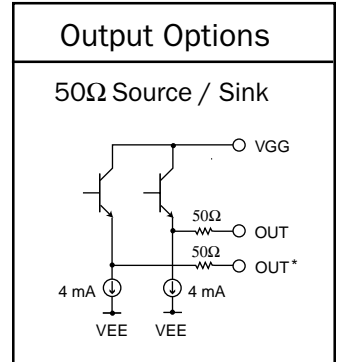

Pin Description

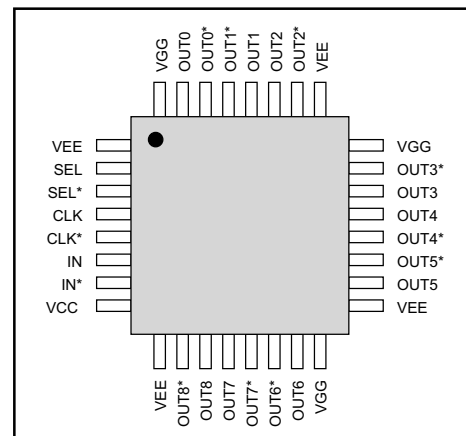

DC Characteristics

Parameter	Symbol	Min	Typ	Max	Units
Inputs					
Input High	V _{IH}	V _{EE} + 2.0		V _{CC}	V
Input Low	V _{IL}	V _{EE}		V _{CC} - .2	V
(IN - IN*, CLK - CLK*, SEL - SEL*) Differential Input Voltage	Input - Input*	.2		4.3	V
Timing Inputs (CLK / CLK*)					
Input High Current	I _{IH}	+1		+25	μA
Input Low Current	I _{IL}	-1		+1	μA
Functional Inputs (IN / IN*, SEL / SEL*) Input Current	I _{IH} , I _{IL}	-420		+250	μA
Outputs					
Digital Output Voltage	OUT - OUT*	600	700		mV
Output Common Mode Range	(OUT + OUT*) / 2	V _{GG} - 1.5	V _{GG} - 1.3	V _{GG} - 1.1	V
Internal Current Source	I _{SINK}	TBD	5	TBD	mA
Output Impedance	R _{OUT}	40	45	50	Ω
Power Supply					
Power Supply Current	I _{EE}		210	265	mA
	I _{CC}		45	52	mA
Positive Supply Voltage	V _{CC}	2.0	3.3	3.6	V
	V _{GG}	-.1	0	2.0	V
Negative Supply Voltage	V _{EE}	-3.6	-3.3	-3.0	V
	V _{CC} - V _{GG}	0		3.6	V

Test Conditions: Outputs unterminated.

AC Characteristics

Parameter	Symbol	Min	Typ	Max	Units
High Performance Option					
Propagation Delay					
CLK to OUT (SEL = 0)	T _{pd}	490	590	690	ps
CLK to OUT (SEL = 1)	T _{pd}	340	440	540	ps
SEL to OUT	T _{pd}	330	430	530	ps
Channel to Channel Skew				<20	ps
Maximum Operating Frequency (Note 1)	F _{max}	3.0			GHz
Minimum Pulse Width (Note 1)	PW min	160			ps
IN to CLK (Note 1)					
Set Up Time	T _{su}	100			ps
Hold Time	T _h	100			ps
Output Rise and Fall Times (20% / 80%)	T _r / T _f		125	150	ps
Temperature Coefficient	ΔT _{pd} / ΔT		<1		ps / °C

Note 1: Guaranteed by characterization. Not production tested.

Description

The SK1929 is an extremely fast, stable, and accurate low skew 1:9 clock / signal distributor featuring a synchronous enable, which allows the outputs to be turned off and on without the risk of an unpredictable output pulse. It is also capable of receiving inputs of any technology and voltage level. The D - flip-flop is triggered on the falling edge of the clock.

The SK1929 uses 50Ω outputs with source /sink capability, and is optimized for:

- High speed clock / data lines that require translation
- Point to point, series termination applications

Features

- 1:9 Clock/Data Driver
- 3 GHz Fmax
- Anything to PECL Translation

Functional Block Diagram

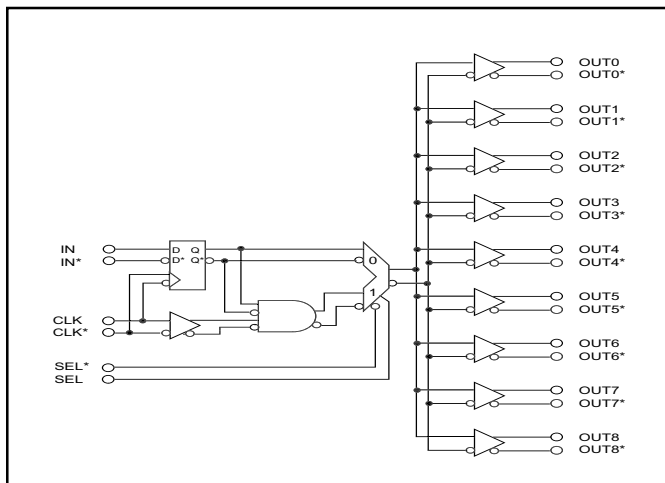

Package Information

32 pin, 5 mm x 5 mm
TQFP Package



Output Options

50Ω Source / Sink

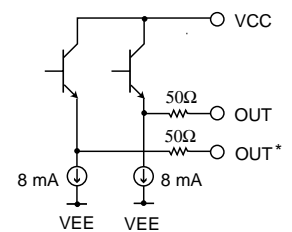

Input Swing

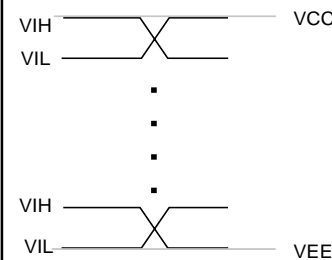

Output Swing

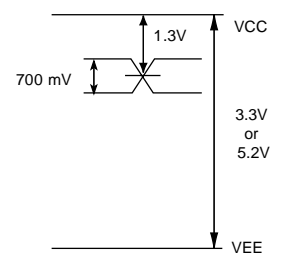

Pin Description

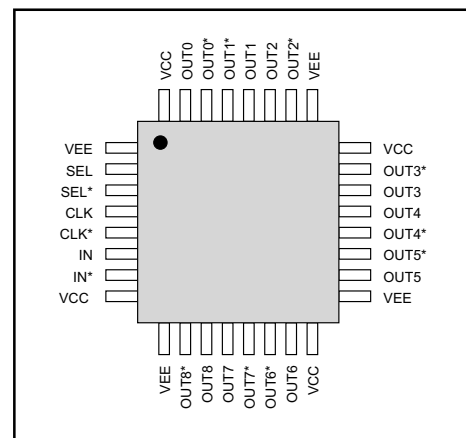

DC Characteristics

Parameter	Symbol	Min	Typ	Max	Units
Inputs					
Input High	V _{IH}	V _{EE} + 2.0		V _{CC}	V
Input Low	V _{IL}	V _{EE}		V _{CC} - .2	V
(IN - IN*, CLK - CLK*, SEL - SEL*) Differential Input Voltage	Input - Input*	.2		4.3	V
Timing Inputs (CLK / CLK*)					
Input High Current	I _{IH}	+1		+25	μA
Input Low Current	I _{IL}	-1		+1	μA
Functional Inputs (IN / IN*, SEL / SEL*) Input Current	I _{IH} , I _{IL}	-420		+250	μA
Outputs					
Digital Output Voltage	OUT - OUT*	600	700		mV
Output Common Mode Range	(OUT + OUT*) / 2	V _{CC} - 1.5	V _{CC} - 1.3	V _{CC} - 1.1	V
Internal Current Source	I _{SINK}	6.5	8	10	mA
Output Impedance	R _{OUT}	40	45	50	Ω
Power Supply					
Power Supply Current	I _{EE}		175	221	mA
Positive Supply Voltage	V _{CC}	3.0	3.3	3.6	V
Negative Supply Voltage	V _{EE}	-3.6	-3.3	-3.0	V

Test Conditions: Outputs unterminated.

AC Characteristics

Parameter	Symbol	Min	Typ	Max	Units
High Performance Option					
Propagation Delay					
CLK to OUT (SEL = 0)	T _{pd}	490	590	690	ps
CLK to OUT (SEL = 1)	T _{pd}	340	440	540	ps
SEL to OUT	T _{pd}	330	430	530	ps
Channel to Channel Skew				<20	ps
Maximum Operating Frequency (Note 1)	F _{max}	3.0			GHz
Minimum Pulse Width (Note 1)	PW min	160			ps
IN to CLK (Note 1)					
Set Up Time	T _{su}	100			ps
Hold Time	T _h	100			ps
Output Rise and Fall Times (20% / 80%)	T _r / T _f		125	150	ps
Temperature Coefficient	ΔT _{pd} / ΔT		<1		ps / °C

Note 1: Guaranteed by characterization. Not production tested.

Description

The SK1930 is an extremely fast, stable and accurate low skew 1:9 clock / signal distributor featuring a synchronous enable, which allows the outputs to be turned off and on without the risk of an unpredictable output pulse. It is also capable of receiving inputs of any technology or voltage level. The D - flip-flop is triggered on the falling edge of the clock.

The SK1930 uses 50Ω outputs with source /sink capability, and is optimized for:

- High speed clock / data lines that require translation
- Point to point, series termination applications

Features

- 1:9 Clock / Data Driver
- 3 GHz Fmax
- Anything to ECL Translation

Functional Block Diagram

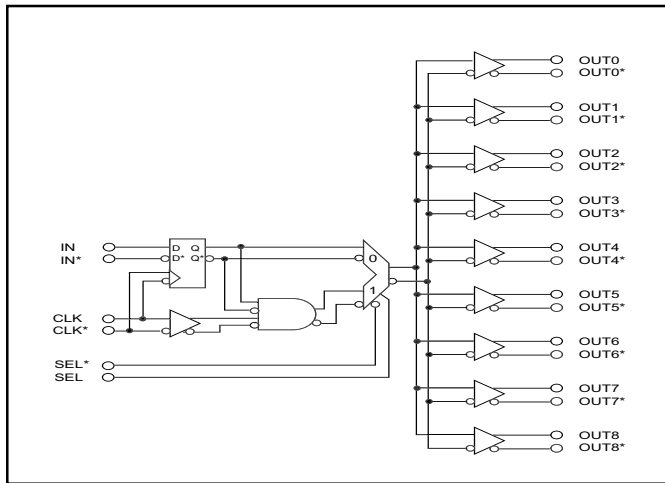

Package Information

32 pin, 5 mm x 5 mm
TQFP Package

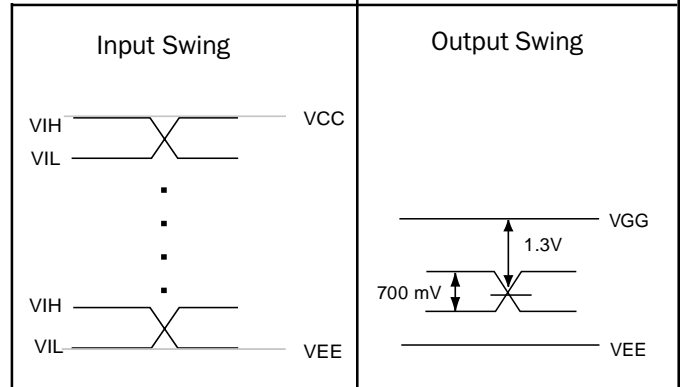
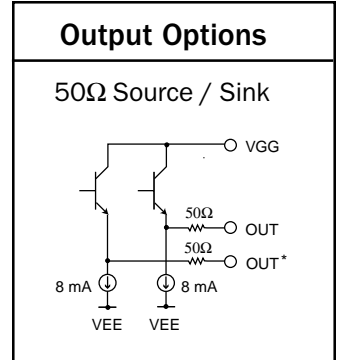

Pin Description

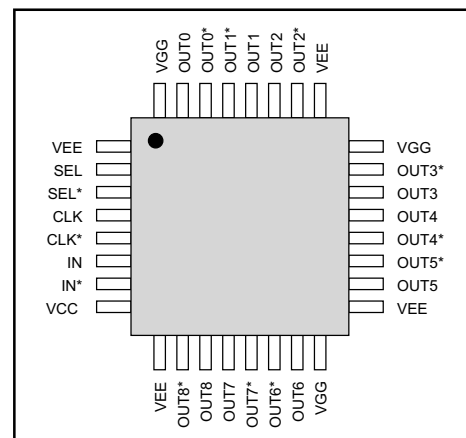

DC Characteristics

Parameter	Symbol	Min	Typ	Max	Units
Inputs					
Input High	V _{IH}	V _{EE} + 2.0		V _{CC}	V
Input Low	V _{IL}	V _{EE}		V _{CC} - .2	V
(IN - IN*, CLK - CLK*, SEL - SEL*) Differential Input Voltage	Input - Input*	.2		4.3	V
Timing Inputs (CLK / CLK*)					
Input High Current	I _{IH}	+1		+25	μA
Input Low Current	I _{IL}	-1		+1	μA
Functional Inputs (IN / IN*, SEL / SEL*) Input Current	I _{IH} , I _{IL}	-420		+250	μA
Outputs					
Digital Output Voltage	OUT - OUT*	600	700		mV
Output Common Mode Range	(OUT + OUT*) / 2	V _{GG} - 1.5	V _{GG} - 1.3	V _{GG} - 1.1	V
Internal Current Source	I _{SINK}	6.5	8	10	mA
Output Impedance	R _{OUT}	40	45	50	Ω
Power Supply					
Power Supply Current	I _{EE}		175	221	mA
	I _{CC}		45	52	mA
Positive Supply Voltage	V _{CC}	2.0	3.3	3.6	V
	V _{GG}	-.1	0	2.0	V
Negative Supply Voltage	V _{EE}	-3.6	-3.3	-3.0	V
	V _{CC} - V _{GG}	0		3.6	V

Test Conditions: Outputs unterminated.

AC Characteristics

Parameter	Symbol	Min	Typ	Max	Units
High Performance Option					
Propagation Delay					
CLK to OUT (SEL = 0)	T _{pd}	490	590	690	ps
CLK to OUT (SEL = 1)	T _{pd}	340	440	540	ps
SEL to OUT	T _{pd}	330	430	530	ps
Channel to Channel Skew				<20	ps
Maximum Operating Frequency (Note 1)	F _{max}	3.0			GHz
Minimum Pulse Width (Note 1)	PW min	160			ps
IN to CLK (Note 1)					
Set Up Time	T _{su}	100			ps
Hold Time	T _h	100			ps
Output Rise and Fall Times (20% / 80%)	T _r / T _f		125	150	ps
Temperature Coefficient	ΔT _{pd} / ΔT		<1		ps / °C

Note 1: Guaranteed by characterization. Not production tested.

Description

Features

The SK1999 is an extremely fast, stable, and accurate low skew 1:9 clock / signal distributor featuring a synchronous enable, which allows the outputs to be turned off and on without the risk of an unpredictable output pulse. The D - flip-flop is triggered on the falling edge of the clock.

- 1:9 Clock/Data Driver
- 3 GHz Fmax
- 3.3V / 5.2V Compatible

The SK1999 has open collector (CML) outputs, targeted for:

- Ultra high speed applications
- Adjustable common mode levels at the destination.

Functional Block Diagram

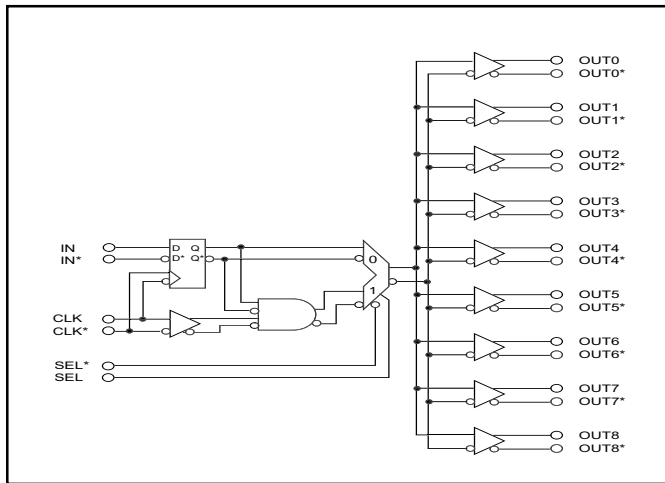

Package Information

32 pin, 5 mm x 5 mm
TQFP Package



Output Options

Open Collector

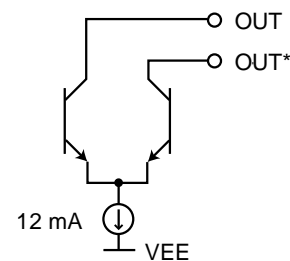

Pin Description

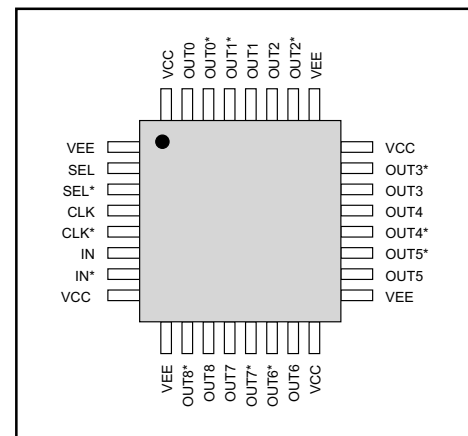

DC Characteristics

Parameter	Symbol	Min	Typ	Max	Units
Inputs					
Input High	V _{IH}	V _{EE} + 2.0		V _{CC}	V
Input Low	V _{IL}	V _{EE}		V _{CC} - 2	V
(IN - IN*, CLK - CLK*, SEL - SEL*) Differential Input Voltage	Input - Input*	.2		4.3	V
Timing Inputs (CLK / CLK*) Input High Current	I _{IH}	+1		+25	μA
Input Low Current	I _{IL}	-1		+1	μA
Functional Inputs (IN / IN*, SEL / SEL*) Input Current	I _{IH} , I _{IL}	-420		+250	μA
Outputs					
Output Current High	I _{OH}	TBD	0	TBD	mA
Output Current Low	I _{OL}	TBD	12	TBD	mA
Power Supply					
Power Supply Current	I _{EE}		185	233	mA
Power Supply Voltage	V _{CC} - V _{EE}	3.0		5.5	V

Test Conditions: Outputs terminated with 50Ω to V_{CC}.

AC Characteristics

Parameter	Symbol	Min	Typ	Max	Units
High Performance Option					
Propagation Delay CLK to OUT (SEL = 0)	T _{pd}	490	590	690	ps
CLK to OUT (SEL = 1)	T _{pd}	340	440	540	ps
SEL to OUT	T _{pd}	330	430	530	ps
Channel to Channel Skew				<20	ps
Maximum Operating Frequency (Note 1)	F _{max}	3.0			GHz
Minimum Pulse Width (Note 1)	PW min	160			ps
IN to CLK (Note 1) Set Up Time	T _{su}	100			ps
Hold Time	T _h	100			ps
Output Rise and Fall Times (20% / 80%)	T _r / T _f		125	150	ps
Temperature Coefficient	ΔT _{pd} / ΔT		<1		ps / °C

Note 1: Guaranteed by characterization. Not production tested.

Ordering Information

Ordering Code	Package ID	Temperature Range
SK1900	32-TQFP 5 x 5 mm	Commercial
SK1901	32-TQFP 5 x 5 mm	Commercial
SK1902	32-TQFP 5 x 5 mm	Commercial
SK1903	32-TQFP 5 x 5 mm	Commercial
SK1904	32-TQFP 5 x 5 mm	Commercial
SK1925	32-TQFP 5 x 5 mm	Commercial
SK1926	32-TQFP 5 x 5 mm	Commercial
SK1927	32-TQFP 5 x 5 mm	Commercial
SK1928	32-TQFP 5 x 5 mm	Commercial
SK1929	32-TQFP 5 x 5 mm	Commercial
SK1930	32-TQFP 5 x 5 mm	Commercial
SK1999	32-TQFP 5 x 5 mm	Commercial

Note: For tape and reel, add the letter "T" at the end of ordering code.

Device Type	Tape Width (mm)	Max Device/Reel	Reel Size (inch)	Max Device/Tube
PLCC-28	24	750	13	37
SOIC-8	12	2,500	13	98
SOIC-16	16	2,500	13	49
SOIC-20	24	1,000	13	38
MSOP-8	12	2,500	13	50
MSOP-10	12	2,500	13	50
LQFP-32 (7 x 7 mm)	16	1,000	13	250 (tray)
TQFP-32 (7 x 7 mm)	16	1,000	13	250 (tray)
TQFP-32 (5 x 5 mm)	16	1,000	13	360 (tray)

Tape and Reel

Semtech's tape and reel packaging fully conforms to the latest EIA-481-1A and EIA-481-2A specifications. The antistatic embossed tape provides a secure cavity sealed with a peel-back cover tape.

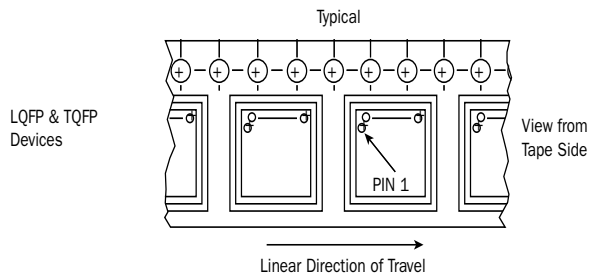
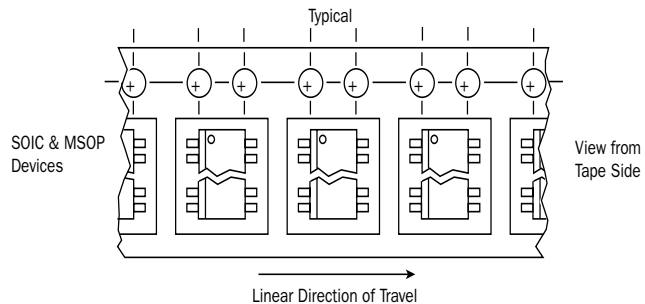
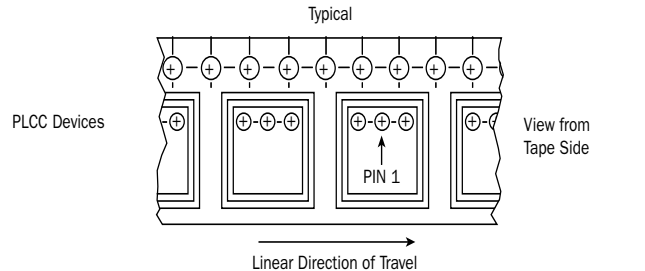

Ordering Information

To order devices which are to be delivered in Tape and Reel, add the suffix T to the device number being ordered.

Contact Information

Division Headquarters
10021 Willow Creek Road
San Diego, CA 92131
Phone (858) 695-1808
FAX (858)695-2633

Semtech Corporation

High-Performance Products Division

Marketing Group
1111 Comstock Street
Santa Clara, CA 95054
Phone: (408) 566-8776
FAX: (408) 727-8994