

Version : 0.1

Preliminary

TECHNICAL SPECIFICATION
MODEL NO. : PM070WT1

Customer's Confirmation

Customer _____

By _____

PVI's Confirmation

FOR MORE INFORMATION:
AZ DISPLAYS, INC.
75 COLUMBIA, ALISO VIEJO, CA, 92656
[Http://www.AZDISPLAYS.com](http://www.AZDISPLAYS.com)

Dep	FAE	Panel Design	Electronic Design	Mechanical Design	Product Verification	Prepared by
SIGN						

TECHNICAL SPECIFICATION

CONTENTS

NO.	ITEM	PAGE
-	Cover	1
-	Contents	2
1	Application	3
2	Features	3
3	Mechanical Specifications	3
4	Mechanical Drawing of TFT-LCD module	4
5	Input Terminals	6
6	Absolute Maximum Ratings	8
7	Electrical Characteristics	8
8	Pixel Arrangement	10
9	Display Color and Gray Scale Reference	11
10	Block Diagram	12
11	Interface Timing	13
12	Power On Sequence	16
13	Optical Characteristics	16
14	Handling Cautions	20
15	Reliability Test	21
16	Packing Diagram	22
	Revision History	-

1. Application

This data sheet applies to a color TFT LCD module, PM070WT1.

The application of panel are OA product, portable DVD, car TV(must use Analog to Digital driving board), which requires high quality flat panel display.

Prime View assume no responsibility for any damage resulting from the use of the device which dose not comply with the instructions and the precautions in these specification sheet.

2. Features

- . Wide VGA (800*480 pixels) resolution
- . Amorphous silicon TFT LCD panel with back-light unit
- . Pixel in stripe configuration
- . Thin and light weight
- . Display Colors : 262,144 colors
- . Optimum Viewing Direction : 6 o'clock
- . +3.3V DC supply voltage for TFT LCD panel driving
- . Backlight driving DC/AC inverter not included in this module
- . Long Life Lamp
- . Wide viewing angle

3. Mechanical Specifications

Parameter	Specifications	Unit
Screen Size	7.0(diagonal)	inch
Display Format	800x(R, G, B)x480	dot
Display Colors	262,144	
Active Area	152.4(H)x91.44(V)	mm
Pixel Pitch	0.190(H)x0.190(V)	mm
Pixel Configuration	Stripe	
Outline Dimension	166.3(W)x105.3 (H)x10.8 (typ.) (D)	mm
Weight	TBD	g
Back-light	CCFL, 1 tube	
Surface treatment	Anti-glare and Wide View Film	
Display mode	Normally white	

4.Mechanical Drawing of TFT-LCD Module
Outline Drawing : Front View (unit mm)

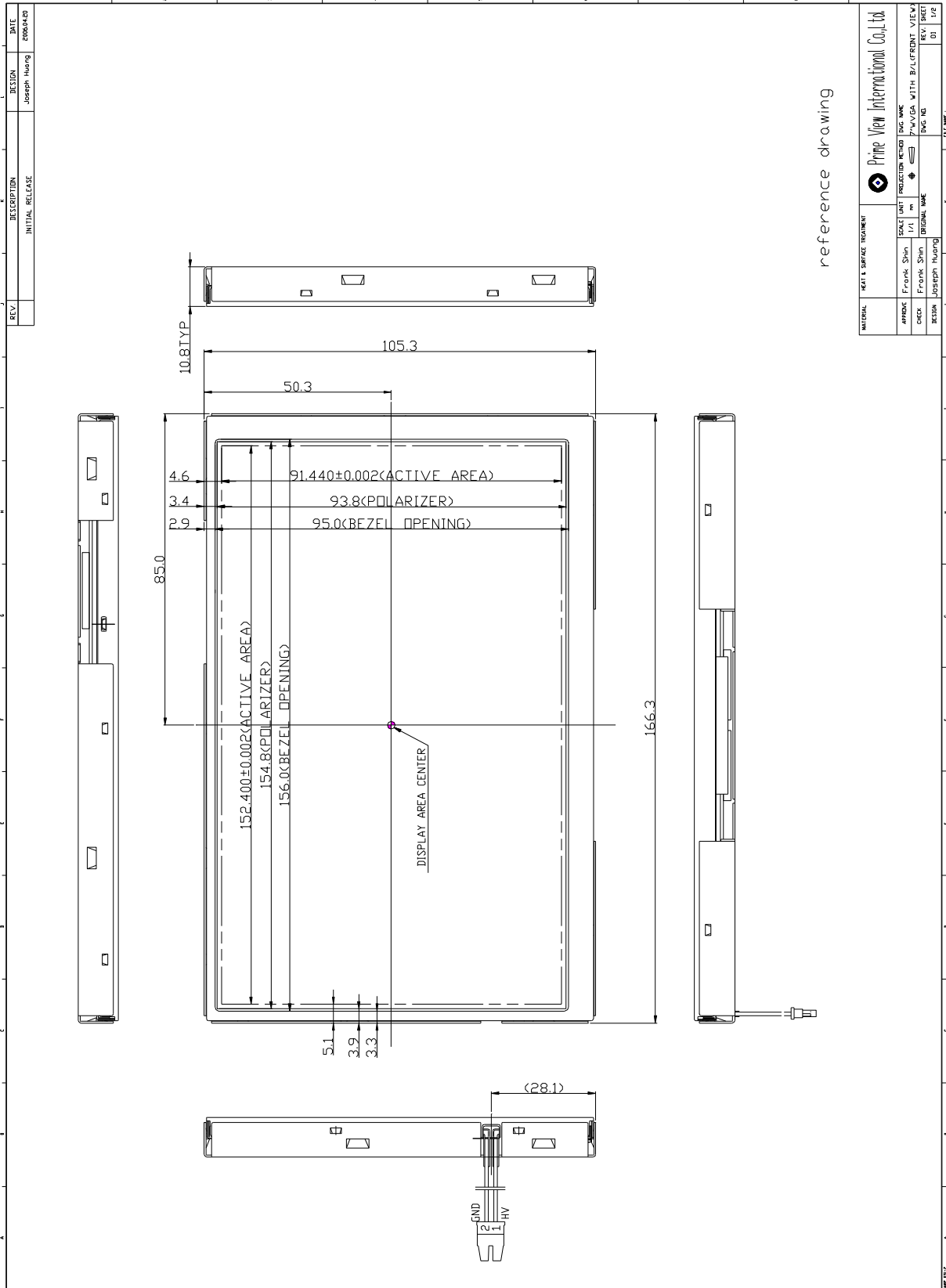

Outline Drawing : Rear View (unit mm)

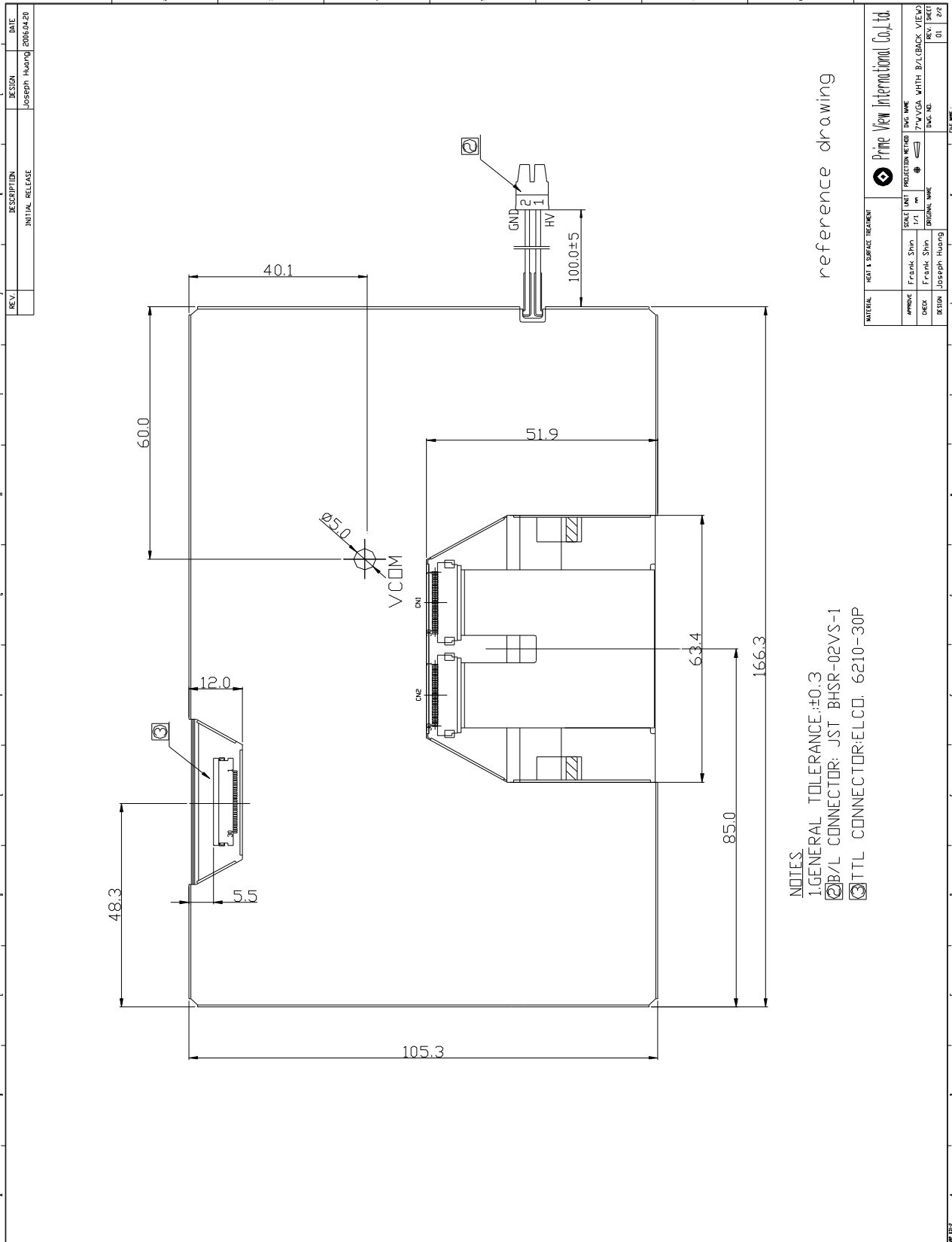

5. Input Terminals

5-1) TFT-LCD Panel Driving

Connector type: ELCO 6210-30P

Pin No.	Symbol	Function	Remark
1	CLK	Clock Signal for Sampling Image Digital Data	
2	Hsync	Horizontal Synchronous Signal	
3	Vsync	Vertical Synchronous Signal	
4	GND	Ground (0V)	
5	R0	Red Image Data Signal (LSB)	
6	R1	Red Image Data Signal	
7	R2	Red Image Data Signal	
8	R3	Red Image Data Signal	
9	R4	Red Image Data Signal	
10	R5	Red Image Data Signal (MSB)	
11	GND	Ground (0V)	
12	G0	Green Image Data Signal (LSB)	
13	G1	Green Image Data Signal	
14	G2	Green Image Data Signal	
15	G3	Green Image Data Signal	
16	G4	Green Image Data Signal	
17	G5	Green Image Data Signal (MSB)	
18	GND	Ground (0V)	
19	B0	Blue Image Data Signal (LSB)	
20	B1	Blue Image Data Signal	
21	B2	Blue Image Data Signal	
22	B3	Blue Image Data Signal	
23	B4	Blue Image Data Signal	
24	B5	Blue Image Data Signal (MSB)	
25	GND	Ground (0V)	
26	DENB	Compound Synchronization signal	Note5-1
27	VCC	DC +3.3V Power Supply	
28	VCC	DC +3.3V Power Supply	
29	R/L	Left / Right control for source driver	Note5-2
30	U/D	Up / Down control for gate driver	Note5-2

Note5-1 DENB input signal.

If customer wanted to off the DENB mode , you must keep the DENB always High or Low.

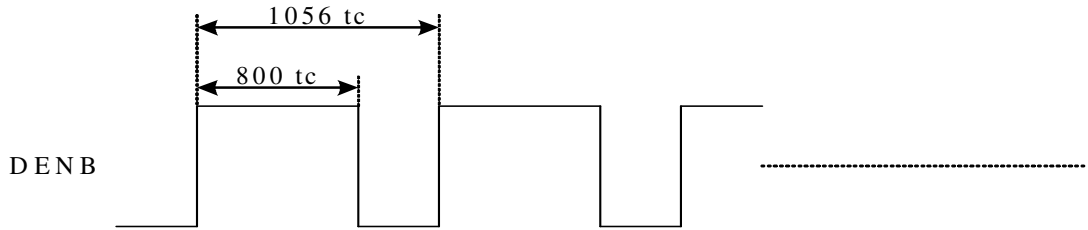

(tc: the period of sampling clock)

Note 5-2 The definitions of U/D & R/L

U/D(PIN 30)=Low R/L(PIN 29)=High

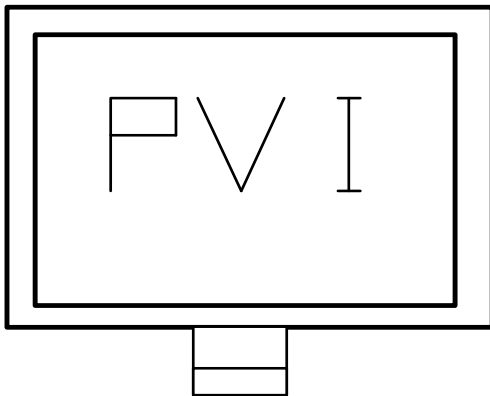

U/D(PIN 30)=High R/L(PIN 29)=Low

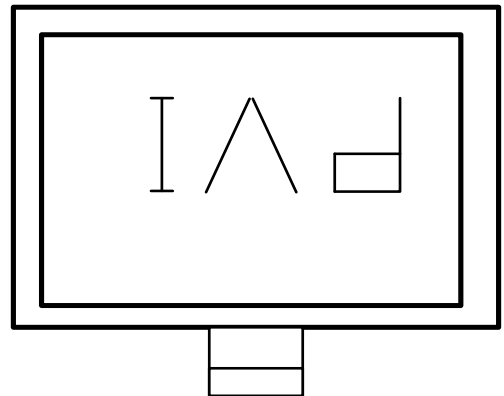

6.Absolute Maximum Ratings:

GND=0V, Ta=25°C

Parameters	Symbol	MIN.	MAX.	Unit	Remark
Supply Voltage	V _{CC}	-0.3	+4.0	V	
Input Signals Voltage	V _{IN}	-0.3	V _{CC} +0.3	V	
Backlight Driving Frequency	F _L	0	100	KHz	

7.Electrical Characteristics

7-1) Recommended Operating Conditions:

GND = 0V · Ta = 25°C

Item	Symbol	Min.	Typ.	Max.	Unit	Remark
Supply Voltage	V _{CC}	3.0	3.3	3.6	V	
Current Dissipation	I _{CC}	-	350	450	mA	Note7-1
LVDS Differential input high threshold	V _{TH}	-	-	100	mV	
LVDS Differential input low threshold	V _{TL}	-100	-	-		

Note 7-1 : To test the current dissipation of VCC using the “color bars” testing pattern shown as below

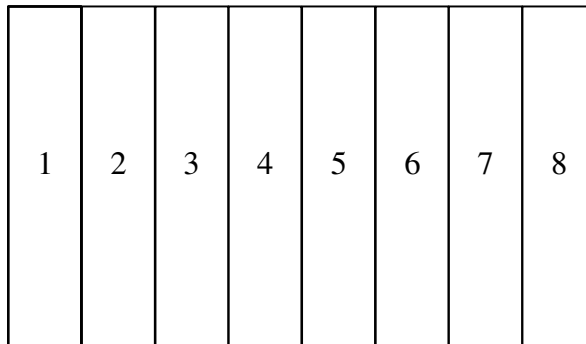

1. White
2. Yellow
3. Cyan
4. Green
5. Magenta
6. Red
7. Blue
8. Black

Idd current dissipation testing pattern

7-2) Recommended Driving Condition for Back Light

Ta=25°C

Parameter	Symbol	Min.	Typ.	Max.	Unit	Remark
Lamp Voltage	V_L	522	580	638	V	$I_L=6mA$
Lamp Current	I_L	4	6	7	mA	Note 7-2
Lamp Frequency	P_L	45	60	80	KHz	Note 7-3
Starting Voltage (25°C) (Reference Value)	V_s	-	-	1090	Vrms	Note 7-4
Starting Voltage (0°C) (Reference Value)	V_s	-	-	1420	Vrms	Note 7-4

Note 7-2 In order to satisfy the quality of B/L, no matter use what kind of inverter, the output lamp current must between Min. and Max. to avoid the abnormal display image caused by B/L.

Note 7-3: The waveform of lamp driving voltage should be as closed to a perfect sine wave as possible.

Note 7-4 The "Max of starting voltage" means the minimum voltage of inverter to turn on the CCFL. and it should be applied to the lamp for more than 1 second to start up. Otherwise the lamp may not be turned on.

7-3) Backlight driving & Power Consumption

Pin No	Symbol	Description	Remark
1	VL1	Input terminal (Hi voltage side)	
2	VL2	Input terminal (Low voltage side)	Note 7-6

Note 7-6 : Low voltage side of backlight inverter connects with ground of inverter circuits.

8. Pixel Arrangement

The LCD module pixel arrangement is the stripe.

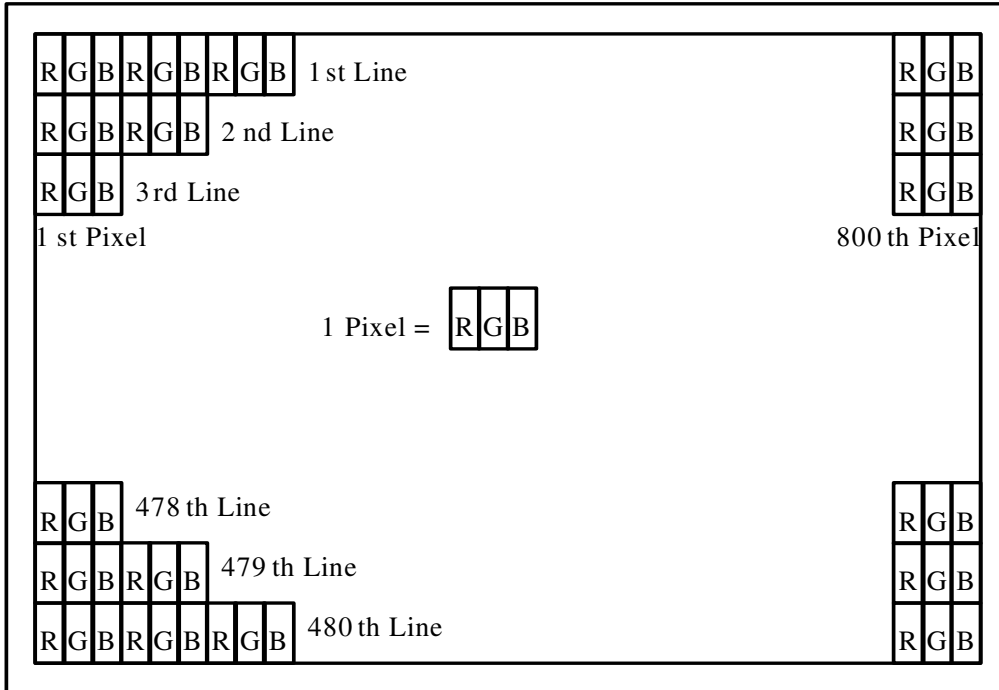

9. Display Color and Gray Scale Reference

Color		Input Color Data																	
		Red					Green					Blue							
		R5	R4	R3	R2	R1	R0	G5	G4	G3	G2	G1	G0	B5	B4	B3	B2	B1	B0
Basic Colors	Black	0	0	0	0	0	0	0	0	0	0	0	0	0	0	0	0	0	0
	Red (63)	1	1	1	1	1	1	0	0	0	0	0	0	0	0	0	0	0	0
	Green (63)	0	0	0	0	0	0	1	1	1	1	1	1	0	0	0	0	0	0
	Blue (63)	0	0	0	0	0	0	0	0	0	0	0	0	1	1	1	1	1	1
	Cyan	0	0	0	0	0	0	1	1	1	1	1	1	1	1	1	1	1	1
	Magenta	1	1	1	1	1	1	0	0	0	0	0	0	1	1	1	1	1	1
	Yellow	1	1	1	1	1	1	1	1	1	1	1	1	0	0	0	0	0	0
	White	1	1	1	1	1	1	1	1	1	1	1	1	1	1	1	1	1	1
Red	Red (00)	0	0	0	0	0	0	0	0	0	0	0	0	0	0	0	0	0	0
	Red (01)	0	0	0	0	0	1	0	0	0	0	0	0	0	0	0	0	0	0
	Red (02)	0	0	0	0	1	0	0	0	0	0	0	0	0	0	0	0	0	0
	Darker																		
	↓	↓	↓	↓	↓	↓	↓	↓	↓	↓	↓	↓	↓	↓	↓	↓	↓	↓	↓
	Brighter																		
	Red (61)	1	1	1	1	0	1	0	0	0	0	0	0	0	0	0	0	0	0
	Red (62)	1	1	1	1	1	0	0	0	0	0	0	0	0	0	0	0	0	0
Red (63)	1	1	1	1	1	1	0	0	0	0	0	0	0	0	0	0	0	0	
Green	Green (00)	0	0	0	0	0	0	0	0	0	0	0	0	0	0	0	0	0	0
	Green (01)	0	0	0	0	0	0	0	0	0	0	0	1	0	0	0	0	0	0
	Green (02)	0	0	0	0	0	0	0	0	0	0	1	0	0	0	0	0	0	0
	Darker																		
	↓	↓	↓	↓	↓	↓	↓	↓	↓	↓	↓	↓	↓	↓	↓	↓	↓	↓	↓
	Brighter																		
	Green (61)	0	0	0	0	0	0	1	1	1	1	0	1	0	0	0	0	0	0
	Green (62)	0	0	0	0	0	0	1	1	1	1	1	0	0	0	0	0	0	0
Green (63)	0	0	0	0	0	0	1	1	1	1	1	1	0	0	0	0	0	0	
Blue	Blue (00)	0	0	0	0	0	0	0	0	0	0	0	0	0	0	0	0	0	0
	Blue (01)	0	0	0	0	0	0	0	0	0	0	0	0	0	0	0	0	0	1
	Blue (02)	0	0	0	0	0	0	0	0	0	0	0	0	0	0	0	0	1	0
	Darker																		
	↓	↓	↓	↓	↓	↓	↓	↓	↓	↓	↓	↓	↓	↓	↓	↓	↓	↓	↓
	Brighter																		
	Blue (61)	0	0	0	0	0	0	0	0	0	0	0	0	1	1	1	1	0	1
	Blue (62)	0	0	0	0	0	0	0	0	0	0	0	0	1	1	1	1	1	0
Blue (63)	0	0	0	0	0	0	0	0	0	0	0	0	1	1	1	1	1	1	

10. Block Diagram

10-2) TFT-module Block Diagram

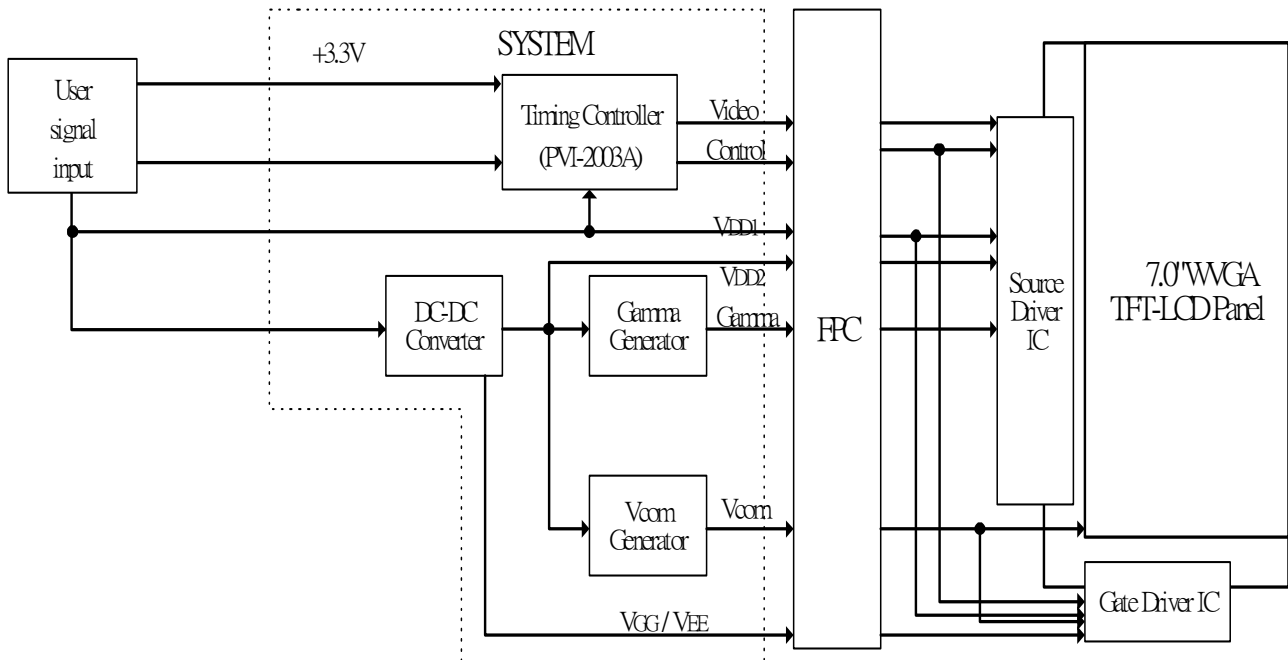

11. Interface Timing

11.1) Timing Parameters

		Symbol	Min.	Typ.	Max.	Unit	Remark	
Power supply		VCC	3.0	3.3	3.6	V		
CLK	Frequency	1/tc	-	32	-	MHz		
		tc	-	31.25	-	ns		
HSYNC	Period	Hp	-	33	-	us		
			-	1056	-	tc		
	Display period	Hdp	-	800	-	tc		
	Pulse width	Hpw	-	128	-	tc		
	Back-porch	Hbp	-	86	-	tc		
	Front-porch	Hfp	-	42	-	tc		
	Hpw+Hbp			-	214	-	tc	
	Hsync-CLK	Hhc	10	-	Tc-10	ns		
	Vsync-Hsync	Hvh	0	0	200	tc		
VSYNC	Period	Vp	-	17.325	-	ms		
			-	525	-	Hp		
	Display period	Vdp	-	480	-	Hp		
	Pulse width	Vpw	-	2	-	Hp		
	Back-porch	Vbp	-	33	-	Hp		
	Front-porch	Vfp	-	10	-	Hp		
	Vpw+Vbp			-	35	-	Hp	
DENB	Horizontal scanning period	T1	860	1056	1064	tc		
	Horizontal display period	T2	-	800	-	tc		
	Vertical display period	T3	-	480	-	T1		
	Frame cycling period	T4	520	525	800	T1		
R,G,B	CLK-DATA	Dcd	10	-	-	ns		
	DATA-CLK	Ddc	8	-	-	ns		

11.2) The Timing Diagram

A. The timing chart for DENB mode
 a-1 CLK data ,relationship

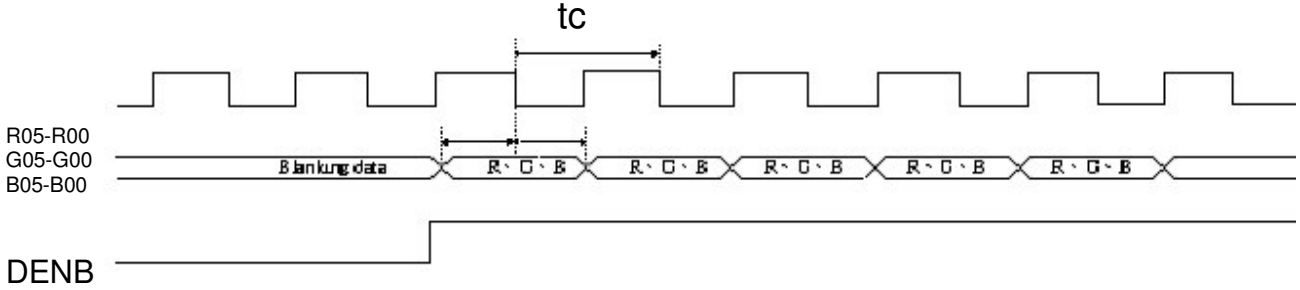

a-2 DENB Timing

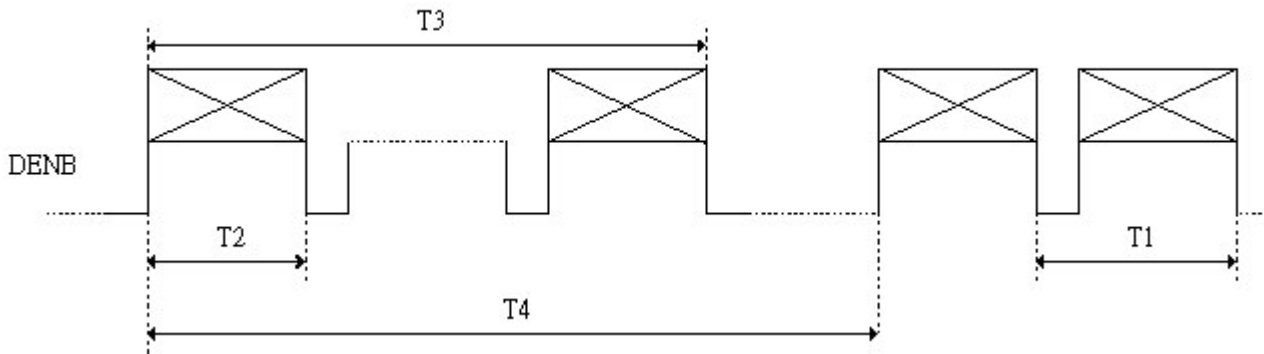

B. The timing chart for sync mode

b-1 CLK Hsync relation ship



b-2 Hsync timing

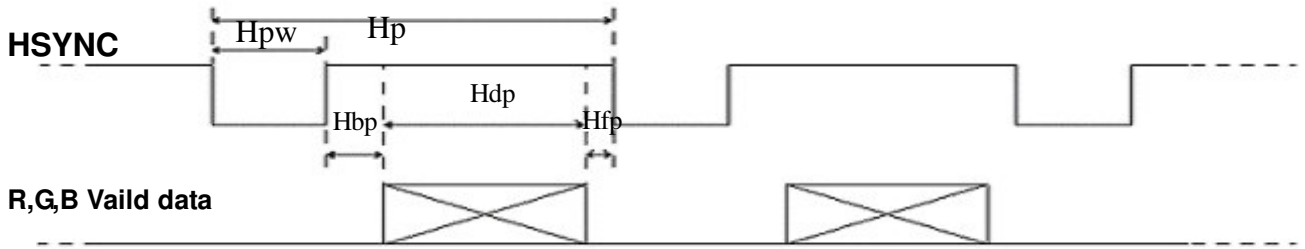

b-3 Hsync ,Vsync relation ship

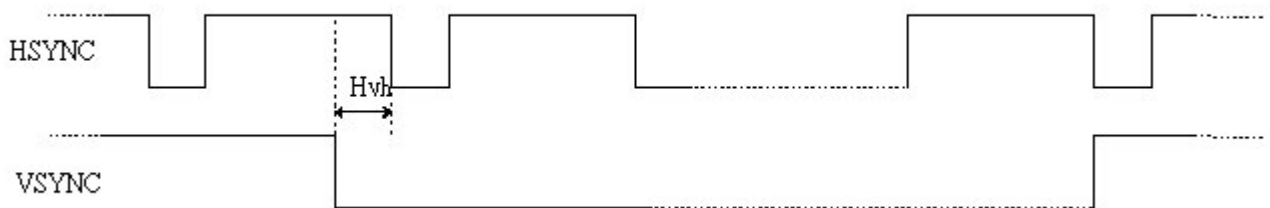

b-4 Vsync Timing

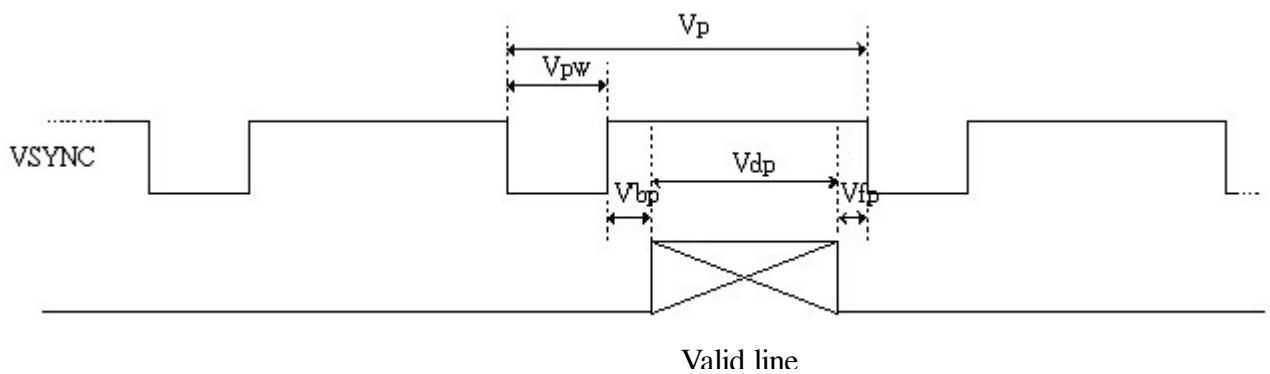

12. Power On Sequence

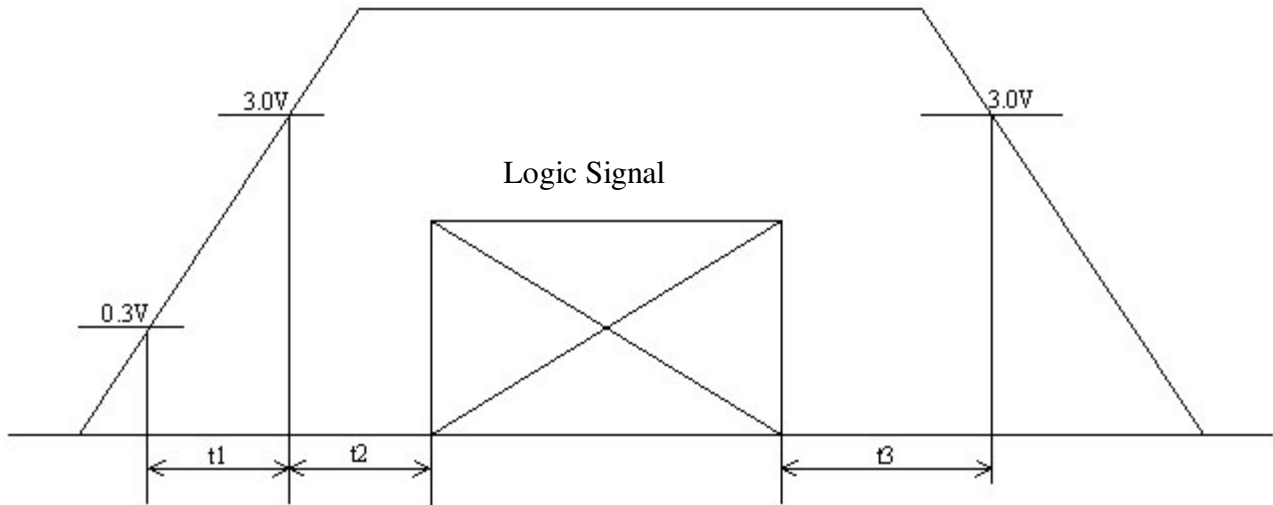

1. $0 < t_1 \leq 20\text{ms}$
2. $0 < t_2 \leq 50\text{ms}$
3. $0 < t_3 \leq 1\text{s}$

13. Optical Characteristics

13-1) Specification:

$T_a=25^\circ\text{C}$

Parameter	Symbol	Condition	MIN.	TYP.	MAX.	Unit	Remarks
Viewing Angle	Horizontal	θ	± 55	± 60	-	deg	Note 13-1
	Vertical	θ (to 12 o'clock)	35	40	-	deg	
		θ (to 6 o'clock)	50	55	-	deg	
Contrast Ratio	CR	$\theta = 0^\circ$	250	400	-	-	Note 13-2
Response time	Rise	T_r	-	15	30	ms	Note 13-3
	Fall	T_f	-	25	50	ms	
Brightness	L	$\theta = 0^\circ / \varphi = 0$	300	330	-	cd/m^2	
Luminance Uniformity	U	-	70	75	-	%	Note 13-4
Lamp Life Time	-	-	25000	-	-	hr	At 6mA
White Chromaticity	x	-	0.27	0.30	0.33	-	
	y	-	0.30	0.33	0.36	-	
Cross Talk	-	$\theta = 0^\circ$	-	-	3.5	%	Note 13-5

All the optical measurement shall be executed 30 minutes after backlight being turn-on. The optical characteristics shall be measured in dark room (ambient illumination on panel surface less than 1 Lux). The measuring configuration shows as following figure.

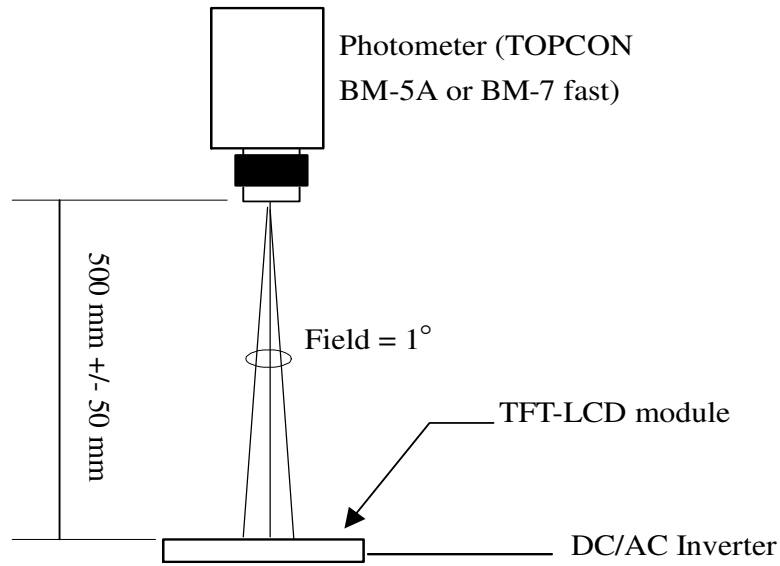

Optical characteristics measuring configuration

Topcon BM-5A or BM-7 fast luminance meter 1° field of view is used in the testing (after 30 minutes' operation). The typical luminance value is measured at lamp current 6.0 mA.

Note 13-1: The definitions of viewing angles are as follow.

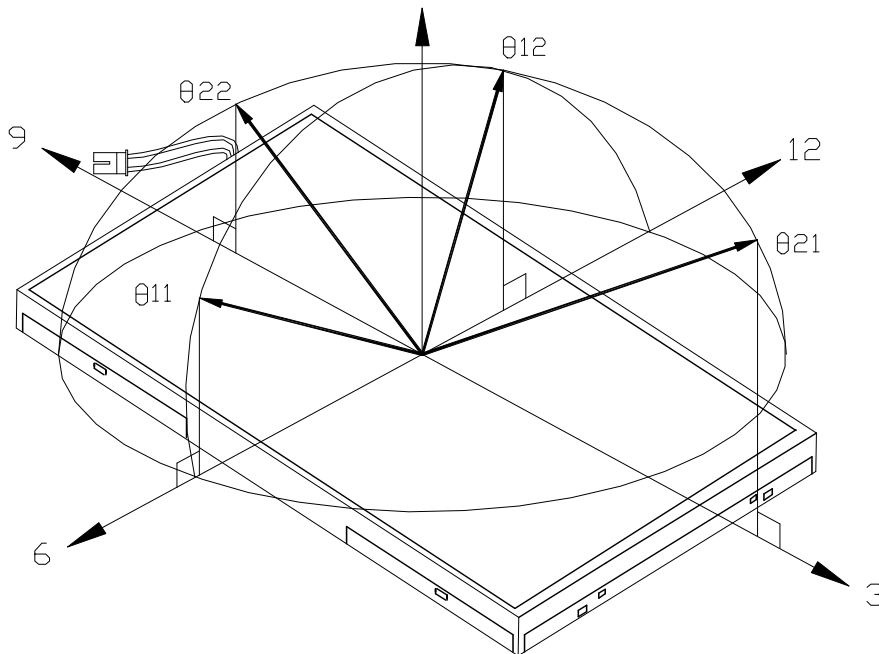

Note 13-2: The definition of contrast ratio $CR = \frac{\text{Luminance at gray level 63}}{\text{Luminance at gray level 0}}$

Note 13-3: Definition of Response Time T_r and T_f :

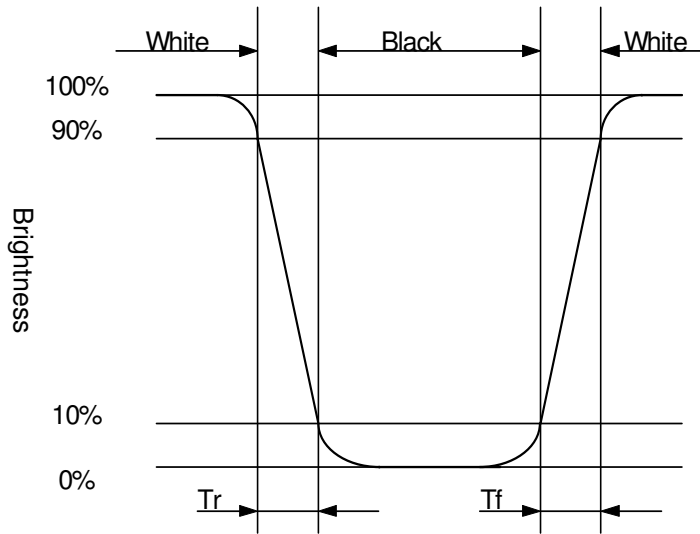

Note 13-4: The uniformity of LCD is defined as

$$U = \frac{\text{The Minimum Brightness of the 9 testing Points}}{\text{The Maximum Brightness of the 9 testing Points}}$$

Luminance meter : BM-5A or BM-7 fast(TOPCON)

Measurement distance : 500 mm +/- 50 mm

Ambient illumination : < 1 Lux

Measuring direction : Perpendicular to the surface of module

The test pattern is white (Gray Level 63).

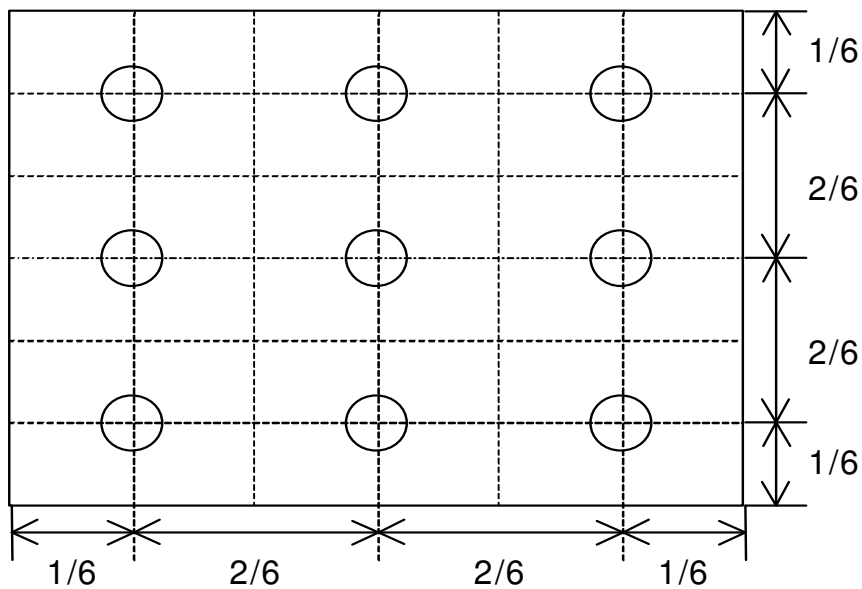

Note 13-5: Cross Talk (CTK) = $\frac{|YA-YB|}{YA} \times 100\%$

YA: Brightness of Pattern A
 YB: Brightness of Pattern B
 Luminance meter : BM 5A or BM-7 fast (TOPCON)
 Measurement distance : 500 mm +/- 50 mm
 Ambient illumination : < 1 Lux
 Measuring direction : Perpendicular to the surface of module

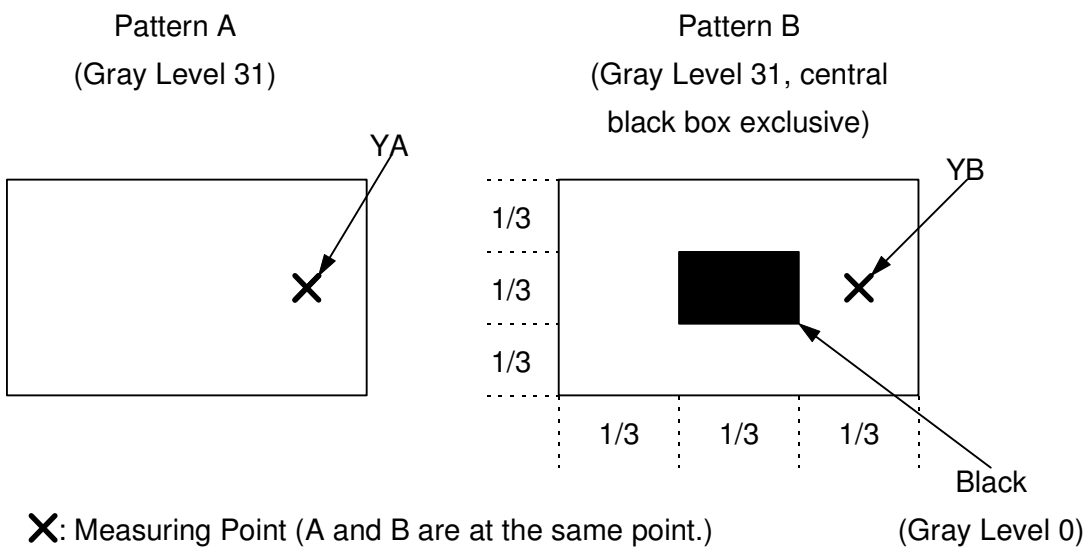

14. Handling Cautions

14-1) Mounting of module

- a) Please power off the module when you connect the input/output connector.
- b) Please connect the ground pattern of the inverter circuit surely. If the connection is not perfect, some following problems may happen possibly.
 - 1.The noise from the backlight unit will increase.
 - 2.The output from inverter circuit will be unstable.
 - 3.In some cases a part of module will heat.
- c) Polarizer which is made of soft material and susceptible to flaw must be handled carefully.
- d) Protective film (Laminator) is applied on surface to protect it against scratches and dirt. It is recommended to peel off the laminator before use and taking care of static electricity.

14-2) Precautions in mounting

- a) When metal part of the TFT-LCD module (shielding lid and rear case) is soiled, wipe it with soft dry cloth.
- b) Wipe off water drops or finger grease immediately. Long contact with water may cause discoloration or spots.
- c) TFT-LCD module uses glass which breaks or cracks easily if dropped or bumped on hard surface. Please handle with care.
- d) Since CMOS LSI is used in the module. So take care of static electricity and earth yourself when handling.

14-3) Adjusting module

- a) Adjusting volumes on the rear face of the module have been set optimally before shipment.
- b) Therefore, do not change any adjusted values. If adjusted values are changed, the specifications described may not be satisfied.

14-4) Others

- a) Do not expose the module to direct sunlight or intensive ultraviolet rays for many hours.
- b) Store the module at a room temperature place.
- c) The voltage of beginning electric discharge may over the normal voltage because of leakage current from approach conductor by to draw lump read lead line around.
- d) If LCD panel breaks, it is possibly that the liquid crystal escapes from the panel. Avoid putting it into eyes or mouth. When liquid crystal sticks on hands, clothes or feet. Wash it out immediately with soap.
- e) Observe all other precautionary requirements in handling general electronic components.
- f) Please adjust the voltage of common electrode as material of attachment by 1 module.

15. Reliability Test

No	Test Item	Test Condition	Remark
1	High Temperature Storage Test	Ta = +80°C, 240 hrs	
2	Low Temperature Storage Test	Ta = -30°C, 240 hrs	
3	High Temperature Operation Test	Ta = +70°C, 240 hrs	
4	Low Temperature Operation Test	Ta = -20°C, 240 hrs	
5	High Temperature & High Humidity Operation Test	Ta = +60°C, 90%RH, 240 hrs (No Condensation)	
6	Thermal Cycling Test (non-operating)	-30°C → +80°C, 100 Cycles 30min 30min	
7	Vibration Test (non-operating)	Frequency : 10 ~ 55 Hz, Amplitude : 1 mm Sweep time: 11 min Test Period: 6 Cycles for each direction of X, Y, Z	
8	Shock Test (non-operating)	100G, 6ms Direction: ±X, ±Y, ±Z Cycle: 3 times	
9	Electrostatic Discharge Test (non-operating)	200pF, 0Ω ±200V 1 time / each terminal	

Ta: ambient temperature

Note : The protective film must be removed before temperature test.

[Criteria]

1. Main LCD should normally work under the normally condition no defect of function, screen quality and appearance (including : mura ,line defect ,no image).
2. After the temperature and humidity test, the luminance and CR (Contrast ratio) ,should not be lower than minimum of specification.
3. After the vibration and shock test , can't be find chip ,broken.

16. Packing Diagram

TBD

Revision History

Rev.	Issued Date	Revised Contents
0.1	Apr.20. 2006	Preliminary