

# MOS FIELD EFFECT TRANSISTORS 2SK2365/2SK2366

## SWITCHING N-CHANNEL POWER MOS FET INDUSTRIAL USE

### DESCRIPTION

The 2SK2365, 2SK2365-Z/2SK2366, 2SK2366-Z is N-Channel MOS Field Effect Transistor designed for high voltage switching applications.

### FEATURES

- Low On-Resistance  
2SK2365:  $R_{DS(on)} = 0.5 \Omega$  ( $V_{GS} = 10 V, I_D = 5.0 A$ )  
2SK2366:  $R_{DS(on)} = 0.6 \Omega$  ( $V_{GS} = 10 V, I_D = 5.0 A$ )
- Low  $C_{iss}$   $C_{iss} = 1\ 600\ pF$  TYP.
- High Avalanche Capability Ratings
- Isolate TO-220 Package

### ABSOLUTE MAXIMUM RATINGS ( $T_A = 25\ ^\circ C$ )

Drain to Source Voltage (2SK2365/2SK2366)	$V_{DSS}$	450/500	V
Gate to Source Voltage	$V_{GSS}$	$\pm 30$	V
Drain Current (DC)	$I_{D(DC)}$	$\pm 10$	A
Drain Current (pulse)*	$I_{D(pulse)}$	$\pm 40$	A
Total Power Dissipation ( $T_c = 25\ ^\circ C$ )	$P_{T1}$	75	W
Total Power Dissipation ( $T_A = 25\ ^\circ C$ )	$P_{T2}$	1.5	W
Channel Temperature	$T_{ch}$	150	$^\circ C$
Storage Temperature	$T_{stg}$	-55 to +150	$^\circ C$
Single Avalanche Current**	$I_{AS}$	10	A
Single Avalanche Energy**	$E_{AS}$	143	mJ

\*  $PW \leq 10\ \mu s$ , Duty Cycle  $\leq 1\ %$

\*\* Starting  $T_{ch} = 25\ ^\circ C$ ,  $R_G = 25\ \Omega$ ,  $V_{GS} = 20\ V \rightarrow 0$

### PACKAGE DIMENSIONS (in millimeters)

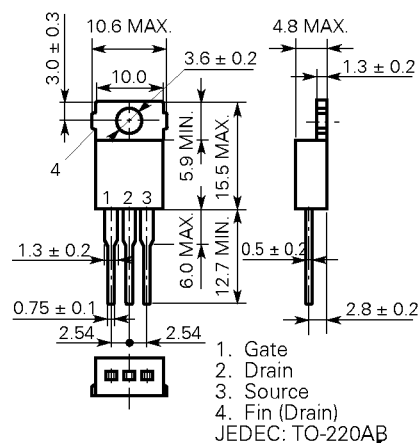

### MP-25 (TO-220)

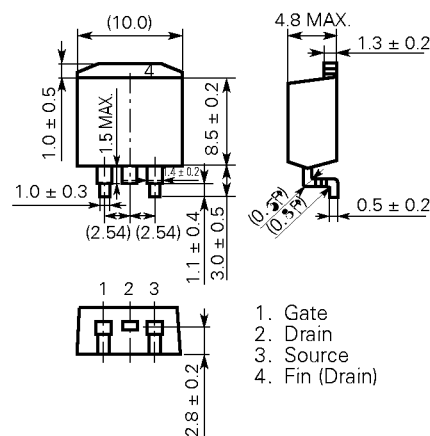

### MP-25Z (SURFACE MOUNT TYPE)

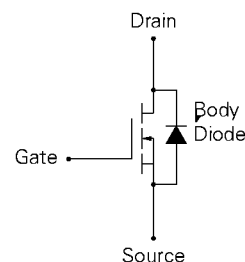

**ELECTRICAL CHARACTERISTICS (TA = 25 °C)**

CHARACTERISTIC	SYMBOL	MIN.	TYP.	MAX.	UNIT	TEST CONDITIONS
Drain to Source On-State Resistance	R <sub>DS(on)</sub>		0.4	0.5	Ω	V <sub>GS</sub> = 10 V 2SK2365
			0.5	0.6		I <sub>D</sub> = 5.0 A 2SK2366
Gate to Source Cutoff Voltage	V <sub>GS(off)</sub>	2.5		3.5	V	V <sub>DS</sub> = 10 V, I <sub>D</sub> = 1 mA
Forward Transfer Admittance	y <sub>fs</sub>	4.0			S	V <sub>DS</sub> = 10 V, I <sub>D</sub> = 5.0 A
Drain Leakage Current	I <sub>DSS</sub>			100	μA	V <sub>DS</sub> = V <sub>DSS</sub> , V <sub>GS</sub> = 0
Gate to Source Leakage Current	I <sub>GSS</sub>			±100	nA	V <sub>GS</sub> = ±30 V, V <sub>DS</sub> = 0
Input Capacitance	C <sub>iss</sub>		1 600		pF	V <sub>DS</sub> = 10 V
Output Capacitance	C <sub>oss</sub>		310			V <sub>GS</sub> = 0
Reverse Transfer Capacitance	C <sub>rss</sub>		30			f = 1 MHz
Turn-On Delay Time	t <sub>d(on)</sub>		30		ns	I <sub>D</sub> = 5.0 A
Rise Time	t <sub>r</sub>		20			V <sub>GS</sub> = 10 V
Turn-Off Delay Time	t <sub>d(off)</sub>		80			V <sub>DD</sub> = 150 V
Fall Time	t <sub>f</sub>		20		ns	R <sub>G</sub> = 10 Ω R <sub>L</sub> = 30 Ω
Total Gate Charge	Q <sub>G</sub>		42			I <sub>D</sub> = 10 A
Gate to Source Charge	Q <sub>GS</sub>		10			V <sub>DD</sub> = 400 V
Gate to Drain Charge	Q <sub>GD</sub>		20		V <sub>GS</sub> = 10 V	
Body Diode Forward Voltage	V <sub>F(S-D)</sub>		1.0		V	I <sub>F</sub> = 10 A, V <sub>GS</sub> = 0
Reverse Recovery Time	t <sub>rr</sub>		350		ns	I <sub>F</sub> = 10 A, V <sub>GS</sub> = 0
Reverse Recovery Charge	Q <sub>rr</sub>		1.5			di/dt = 50 A/μs

**Test Circuit 1 Avalanche Capability**

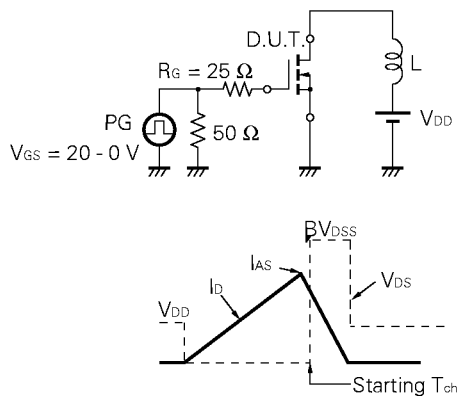

**Test Circuit 2 Switching Time**

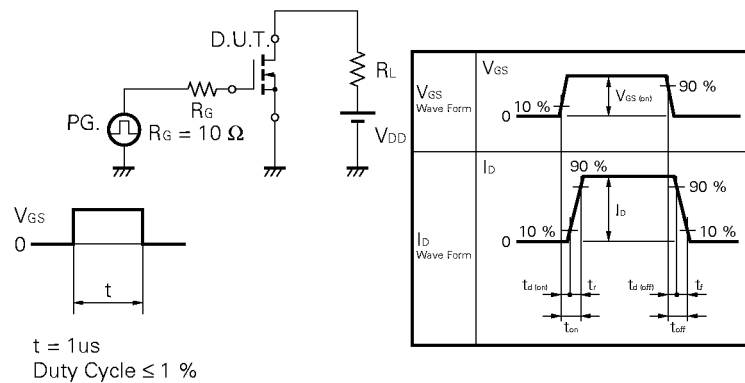

**Test Circuit 3 Gate Charge**

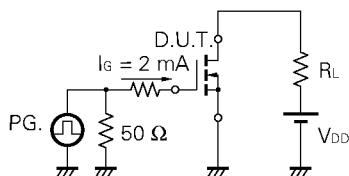

The application circuits and their parameters are for references only and are not intended for use in actual design-in's.

TYPICAL CHARACTERISTICS (T<sub>A</sub> = 25 °C)

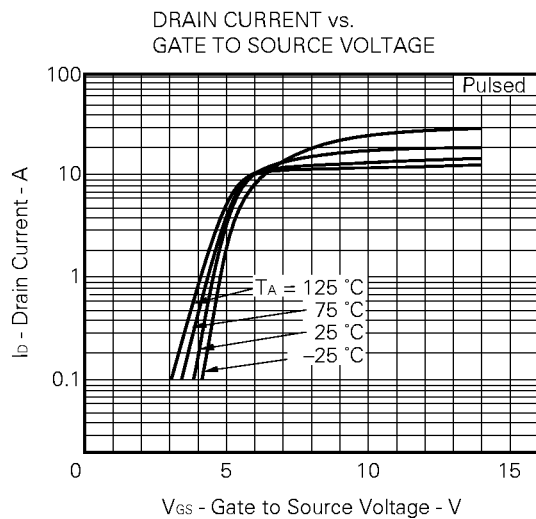
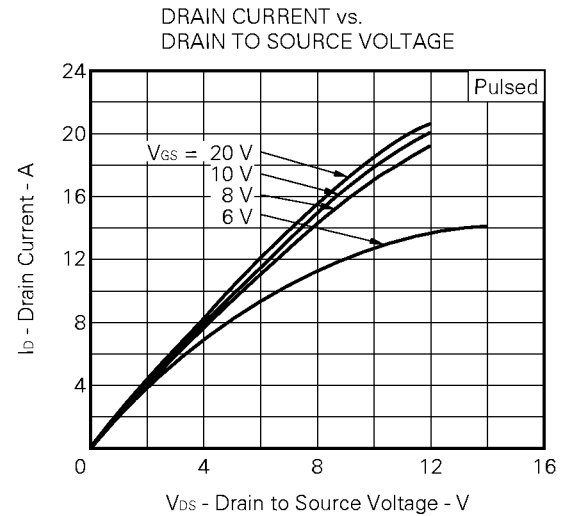
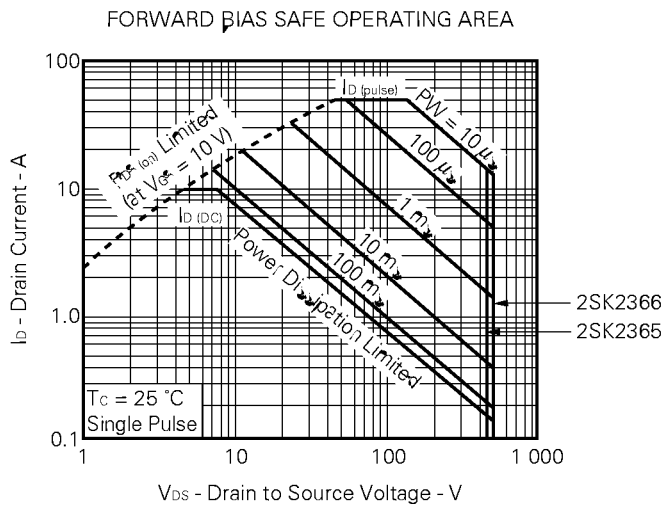
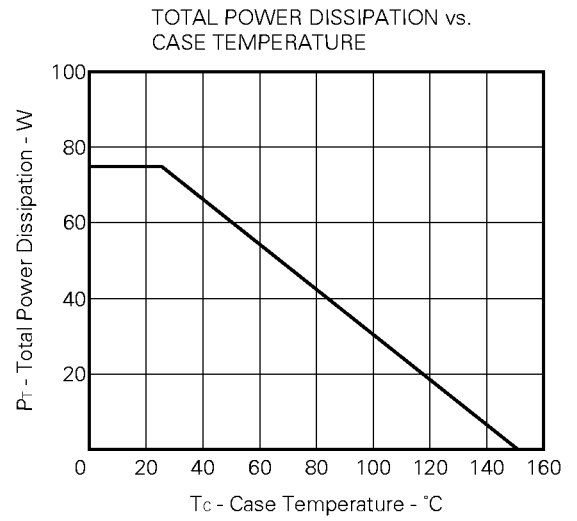
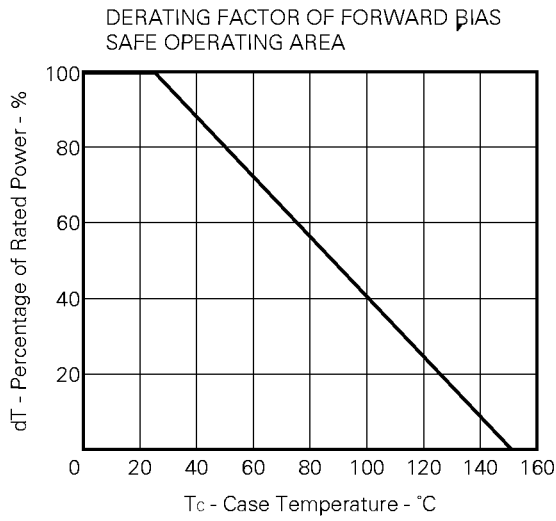

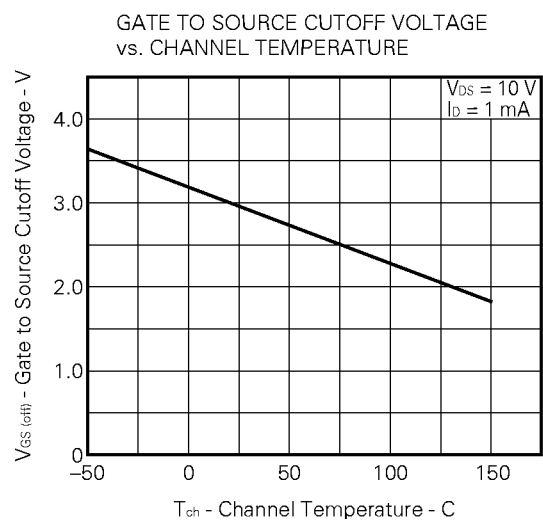
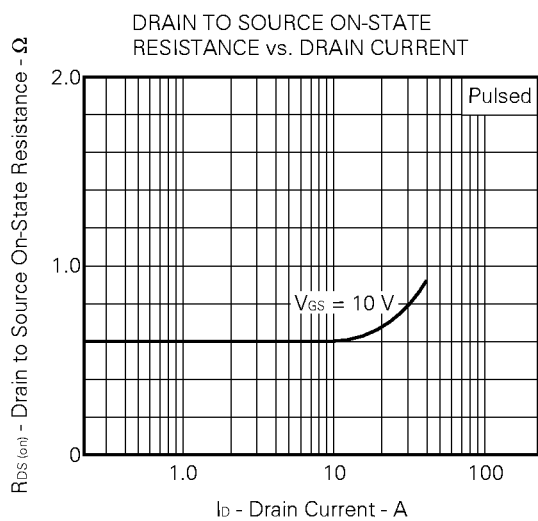
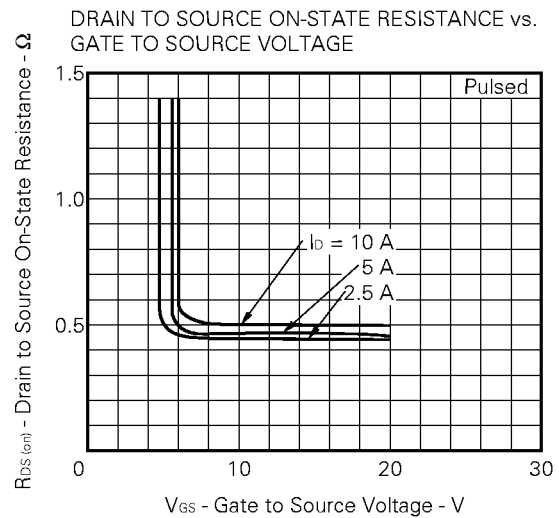
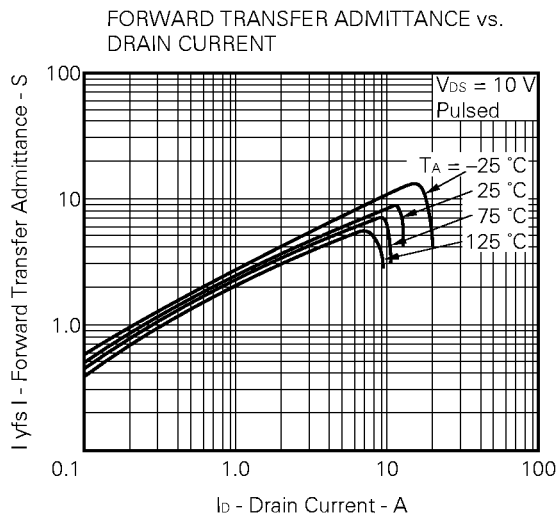
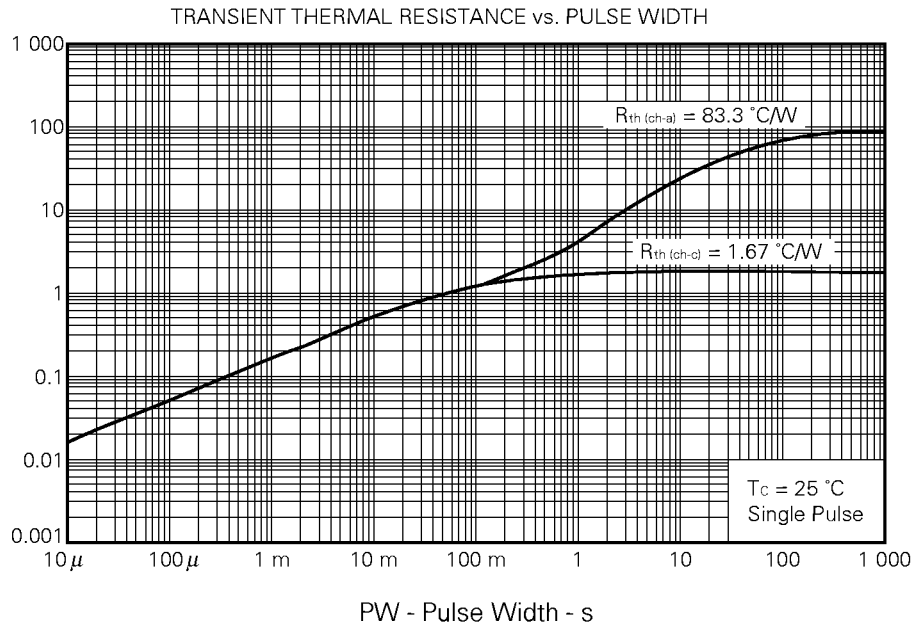

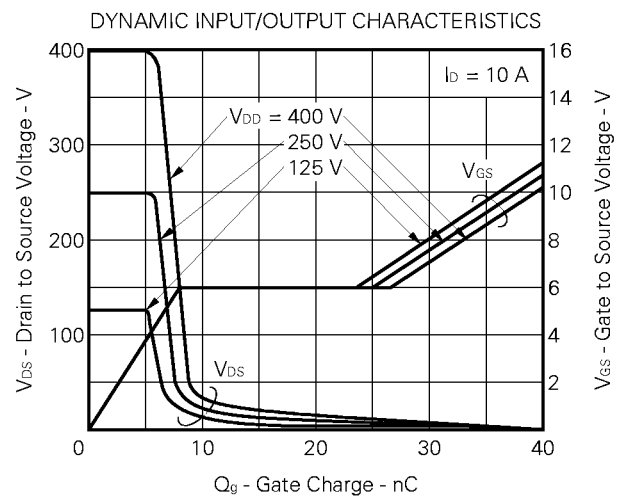
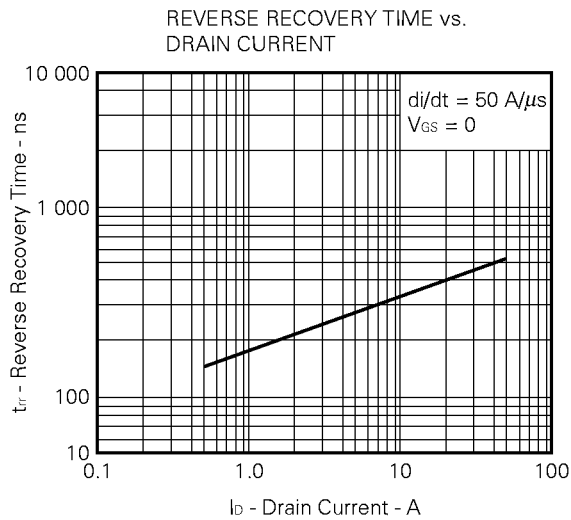
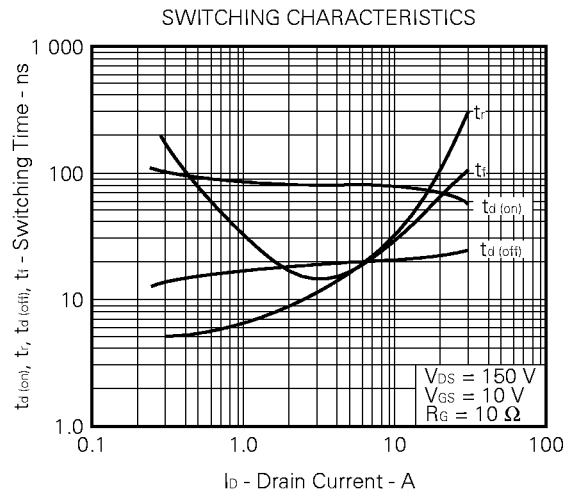
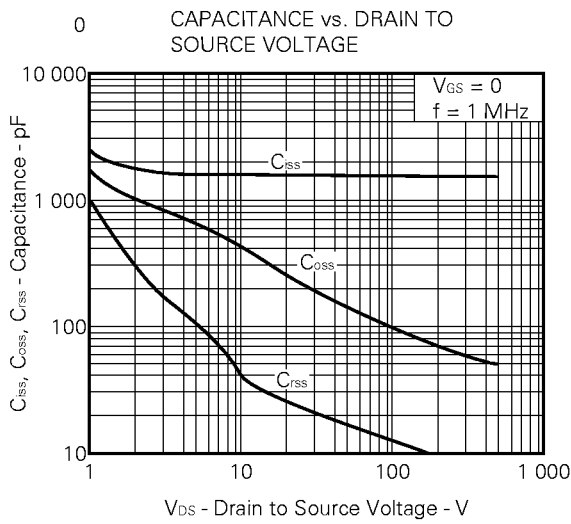
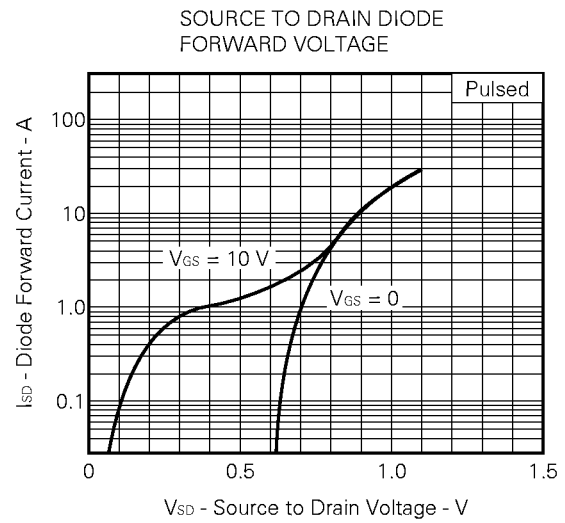
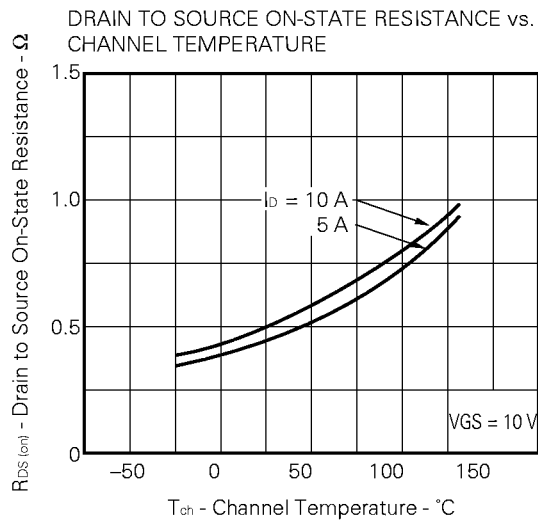

SINGLE AVALANCHE ENERGY vs. STARTING CHANNEL TEMPERATURE

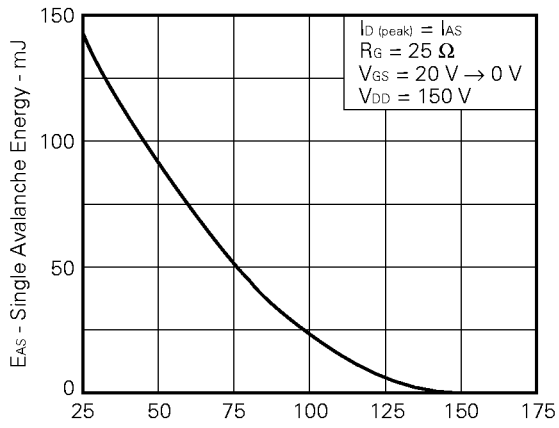

SINGLE AVALANCHE CURRENT vs. INDUCTIVE LOAD

