

P6SMB220 ... P6SMB550CA

Surface mount unidirectional and bidirectional Transient Voltage Suppressor Diodes Unidirektionale und bidirektionale Spannungs-Begrenzer-Dioden für die Oberflächenmontage

Version 2011-06-15

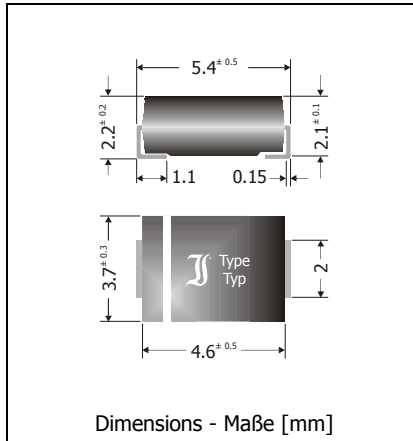

Peak pulse power dissipation Impuls-Verlustleistung	600 W
Nominal breakdown voltage Nominale Abbruch-Spannung	220...550 V
Plastic case Kunststoffgehäuse	~ SMB ~ DO-214AA
Weight approx. – Gewicht ca.	0.1 g
Plastic material has UL classification 94V-0 Gehäusematerial UL94V-0 klassifiziert	
Standard packaging taped and reeled Standard Lieferform gurgtet auf Rollen	



For bidirectional types, suppressor characteristics apply in both directions; add suffix "C" or "CA".
Für bidirektionale Dioden gelten die Begrenzer-Eigenschaften in beiden Richtungen;
es ist das Suffix "C" oder "CA" zu ergänzen.

**TVS diodes having stand-off voltage $V_{WM} = 5.0 \dots 170 \text{ V}$:
please refer to datasheet P6SMBJ5.0 ... 170CA**
**TVS-Dioden mit Sperrspannung $V_{WM} = 5.0 \dots 170 \text{ V}$:
siehe Datenblatt P6SMBJ5.0 ... 170CA**

Maximum ratings and Characteristics

Grenz- und Kennwerte

Peak pulse power dissipation (10/1000 μs waveform) Impuls-Verlustleistung (Strom-Impuls 10/1000 μs)	$T_A = 25^\circ\text{C}$	P_{PPM}	600 W ¹⁾
Steady state power dissipation Verlustleistung im Dauerbetrieb	$T_T = 75^\circ\text{C}$	$P_{M(AV)}$	5 W
Peak forward surge current, 60 Hz half sine-wave Stoßstrom für eine 60 Hz Sinus-Halbwellen	$T_A = 25^\circ\text{C}$	I_{FSM}	100 A ²⁾
Max. instantaneous forward voltage Augenblickswert der Durchlass-Spannung	$I_F = 25 \text{ A}$	V_F	< 3.0 V ²⁾
Operating junction temperature – Sperrschichttemperatur Storage temperature – Lagerungstemperatur		T_j T_S	-50...+150°C -50...+150°C
Thermal resistance junction to ambient air Wärmewiderstand Sperrschicht – umgebende Luft		R_{thA}	< 45 K/W ³⁾
Thermal resistance junction to terminal Wärmewiderstand Sperrschicht – Anschluss		R_{thT}	< 15 K/W

- 1 Non-repetitive pulse see curve $I_{pp} = f(t) / P_{pp} = f(t)$
Höchstzulässiger Spitzenwert eines einmaligen Impulses, siehe Kurve $I_{pp} = f(t) / P_{pp} = f(t)$
- 2 Unidirectional diodes only – Nur für unidirektionale Dioden
- 3 Mounted on P.C. board with 50 mm² copper pads at each terminal
Montage auf Leiterplatte mit 50 mm² Kupferbelag (Löt-pad) an jedem Anschluss

Maximum ratings
Grenzwerte

Type Typ	Breakdown voltage at $I_T = 1 \text{ mA}$ Abbruch-Spannung bei $I_T = 1 \text{ mA}$		Stand-off voltage Sperrspannung	Max. rev. current Max. Sperrstrom at / bei V_{WM}	Max. clamping voltage Max. Begrenzer-Spannung at / bei I_{PPM} (10/1000 μs)	
bidir. = C / CA	V_{BR} [V]		V_{WM} [V]	I_D [μA]	V_C [V]	I_{PPM} [A]
P6SMBJ5.0 ... P6SMBJ170CA $\rightarrow V_{BR} = 7.2 \dots 200\text{V}$						
P6SMB220	$220 \pm 10\%$	198...242	175	5	344	1.7
P6SMB220A	$220 \pm 5\%$	209...231	185	5	328	1.8
P6SMB250	$250 \pm 10\%$	225...275	202	5	360	1.7
P6SMB250A	$250 \pm 5\%$	237...263	214	5	344	1.7
P6SMB300	$300 \pm 10\%$	270...330	243	5	430	1.4
P6SMB300A	$300 \pm 5\%$	285...315	256	5	414	1.4
P6SMB350	$350 \pm 10\%$	315...385	284	5	504	1.2
P6SMB350A	$350 \pm 5\%$	332...368	300	5	482	1.2
P6SMB400	$400 \pm 10\%$	360...440	324	5	574	1.0
P6SMB400A	$400 \pm 5\%$	380...420	342	5	548	1.1
P6SMB440	$440 \pm 10\%$	396...484	356	5	631	1.0
P6SMB440A	$440 \pm 5\%$	418...462	376	5	602	1.0
P6SMB480	$480 \pm 10\%$	432...528	388	5	686	0.87
P6SMB480A	$480 \pm 5\%$	456...504	408	5	658	0.91
P6SMB530	$530 \pm 10\%$	477...583	429	5	764	0.79
P6SMB530A	$530 \pm 5\%$	503...556	477	5	729	0.82
P6SMB550	$550 \pm 10\%$	495...605	445	5	793	0.76
P6SMB550A	$550 \pm 5\%$	522...577	495	5	760	0.79

TVS diodes having stand-off voltage $V_{WM} = 5.0 \dots 170 \text{ V}$:
please refer to datasheet P6SMBJ5.0 ... 170CA
TVS-Dioden mit Sperrspannung $V_{WM} = 5.0 \dots 170 \text{ V}$:
siehe Datenblatt P6SMBJ5.0 ... 170CA

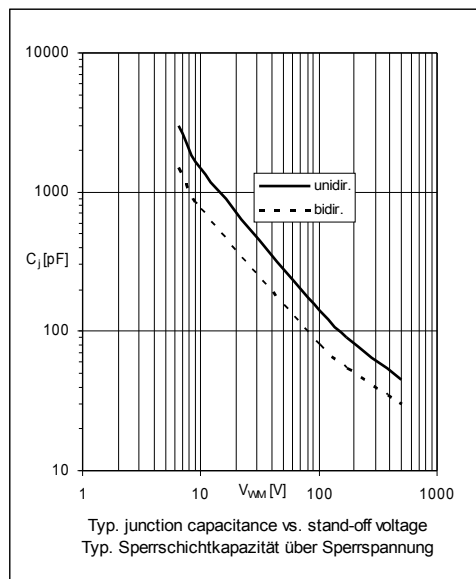
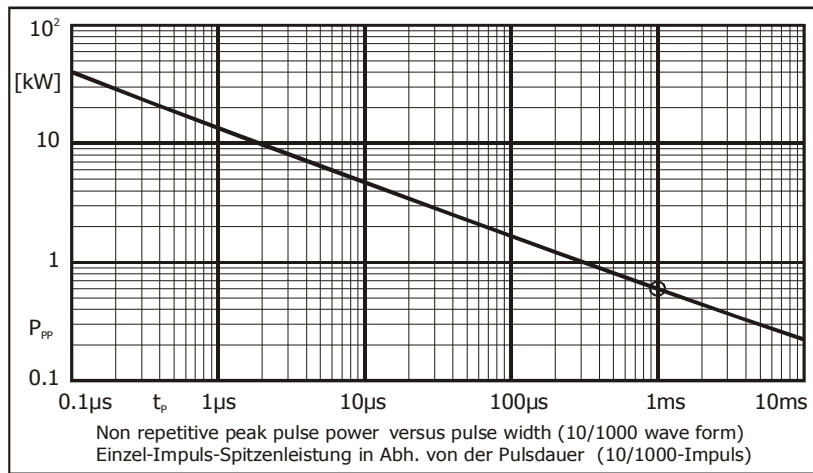
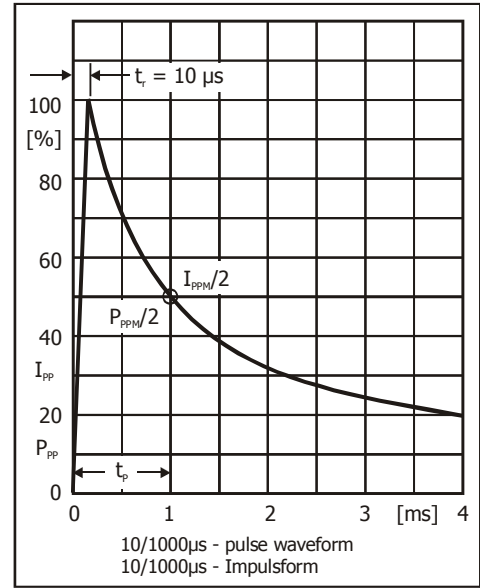
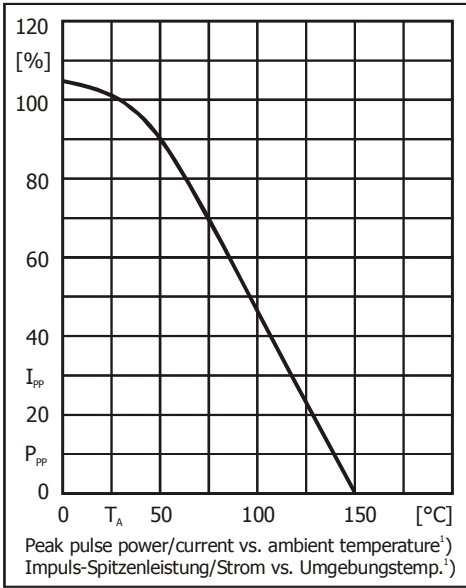

1 Mounted on P.C. board with 50 mm² copper pads at each terminal
 Montage auf Leiterplatte mit 50 mm² Kupferbelag (Lötpad) an jedem Anschluss