

Series J Pneumatic Switch Mechanism

Installation and Operating Manual

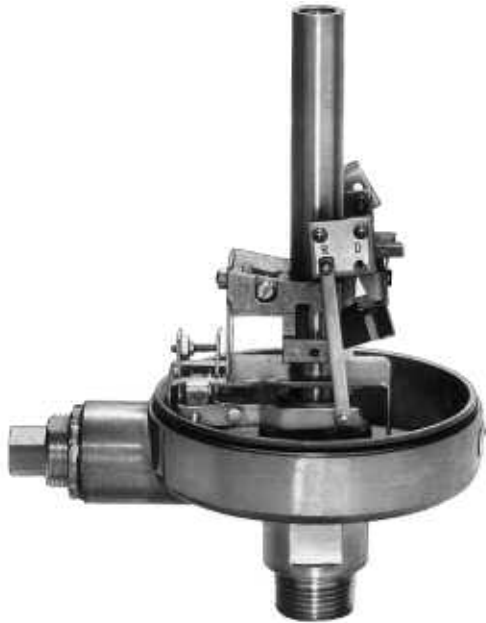

*Bleed
Type
Valve
for
Liquid
Level
Switches*

Read this Manual Before Installing

This manual provides information on the Series J Pneumatic Switch Mechanism. It is important that all instructions are read carefully and followed in sequence. Detailed installation and hook-up instructions are included in this manual.

Conventions Used in this Manual

Certain conventions are used in this manual to convey specific types of information. General technical material, support data, and safety information are presented in narrative form. The following styles are used for notes, cautions, and warnings.

Notes

Notes contain information that augments or clarifies an operating step. Notes do not normally contain actions. They follow the procedural steps to which they refer.

Cautions

Cautions alert the technician to special conditions that could injure personnel, damage equipment, or reduce a component's mechanical integrity. Cautions are also used to alert the technician to unsafe practices or the need for special protective equipment or specific materials. In this manual, a caution box indicates a potentially hazardous situation which, if not avoided, may result in minor or moderate injury.

Warnings

Warnings identify potentially dangerous situations or serious hazards. In this manual, a warning indicates an imminently hazardous situation which, if not avoided, could result in serious injury or death.

Safety Messages

Follow all standard industry procedures for servicing electrical equipment when working with or around high voltage. Always shut off the power supply before touching any components.

Low Voltage Directive

For use in Installations Category II, Pollution Degree 2. If equipment is used in a manner not specified by the manufacturer, protection provided by equipment may be impaired.

Notice of Copyright, and Limitations

Copyright © 2009 Magnetrol International, Incorporated. All rights reserved.

Magnetrol reserves the right to make changes to the product described in this manual at any time without notice. Magnetrol makes no warranty with respect to the accuracy of the information in this manual.

Warranty

All Magnetrol mechanical level and flow controls are warranted free of defects in materials or workmanship for five full years from the date of original factory shipment.

If returned within the warranty period; and, upon factory inspection of the control, the cause of the claim is determined to be covered under the warranty; then, Magnetrol will repair or replace the control at no cost to the purchaser (or owner) other than transportation.

Magnetrol shall not be liable for misapplication, labor claims, direct or consequential damage or expense arising from the installation or use of equipment. There are no other warranties expressed or implied, except special written warranties covering some Magnetrol products.

Quality Assurance

The quality assurance system in place at Magnetrol guarantees the highest level of quality throughout the company. Magnetrol is committed to providing full customer satisfaction both in quality products and quality service.

Magnetrol's quality assurance system is registered to ISO 9001 affirming its commitment to known international quality standards providing the strongest assurance of product/service quality available.



1.0 Description

The Series 'J' Pneumatic Switch is a single airline, bleed type valve with a magnetically actuated flapper. The movement of the magnet assembly causes the switch to change state, either moving the flapper away from the nozzle allowing the pressure in the line to vent or moving the flapper against the nozzle causing pressure to build up in the line.

2.0 Principle of Operation

Figure 1 shows the attraction sleeve and magnet in the position when the liquid level is such that the attraction sleeve is below the field of the magnet. In this position, the flapper has been drawn away from the nozzle by the fall-out spring; and, air flows faster through the nozzle than it can be supplied through the restriction. The air pressure to the control valve then drops to zero.

Figure 2 shows the attraction sleeve when it is within the field of the magnet. When a change in the liquid level moves the attraction sleeve into the field of the magnet, it causes the magnet to pull in against the enclosing tube. In this position, the flapper is held against the nozzle, thus shutting off the bleed of air. The air pressure to the control valve builds up to supply pressure. The switch is reversible with two simple adjustments described on page 4.

NOTE: Clean, dry, regulated air should be used with the pneumatic switch.

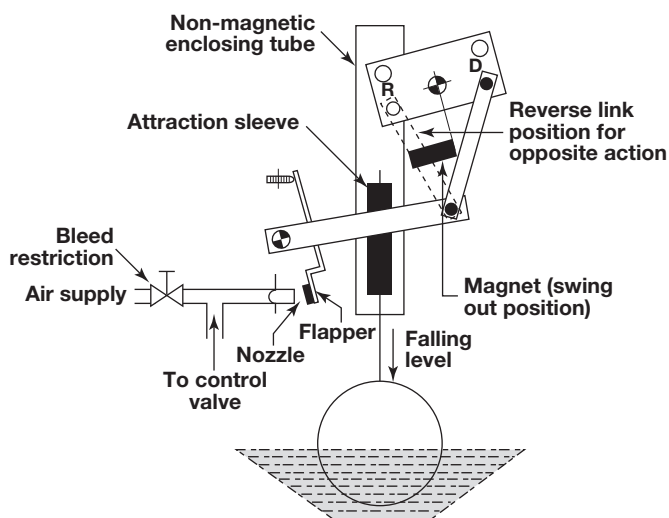

Figure 1
Attraction sleeve below field of magnet

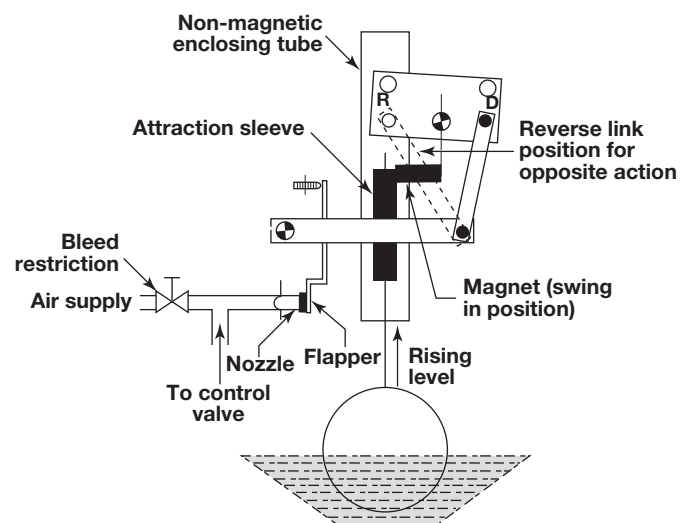

Figure 2
Attraction sleeve in field of magnet

3.0 Reversing Pilot Action

All Series J Pneumatic Switch Mechanisms are shipped from the factory set-up for direct action; closed at high level. They can be field modified for the reverse (open) position by following the steps below:

1. First remove the upper shoulder screw from the actuator link and move it from the direct (D) position to the reverse (R); refer to Figure 3.
2. Loosen the screw that positions the spring bracket and move it from the direct (D) position to the reverse (R) position; refer to Figure 4.
3. Fasten screw securely.

The switch is now setup for reverse action.

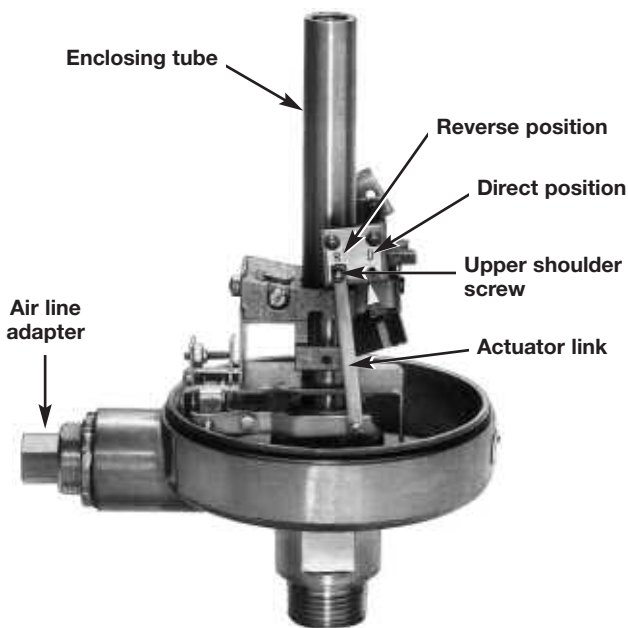

Figure 3

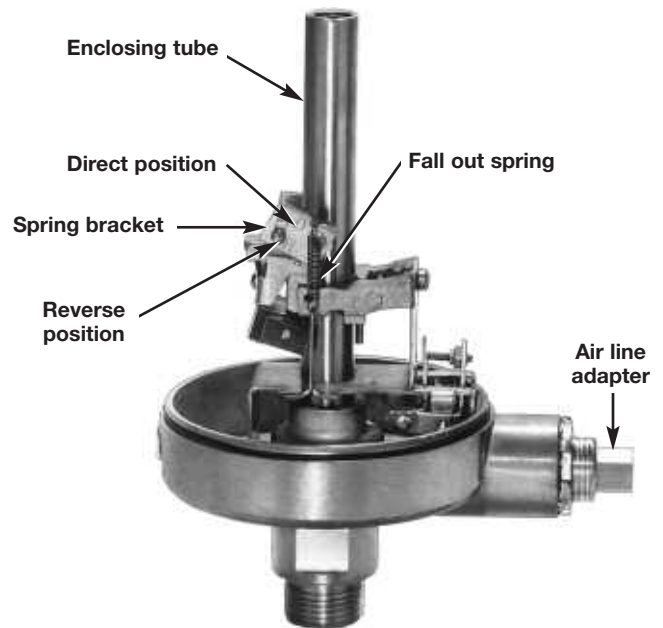

Figure 4

4.0 Locating Air Line Connection

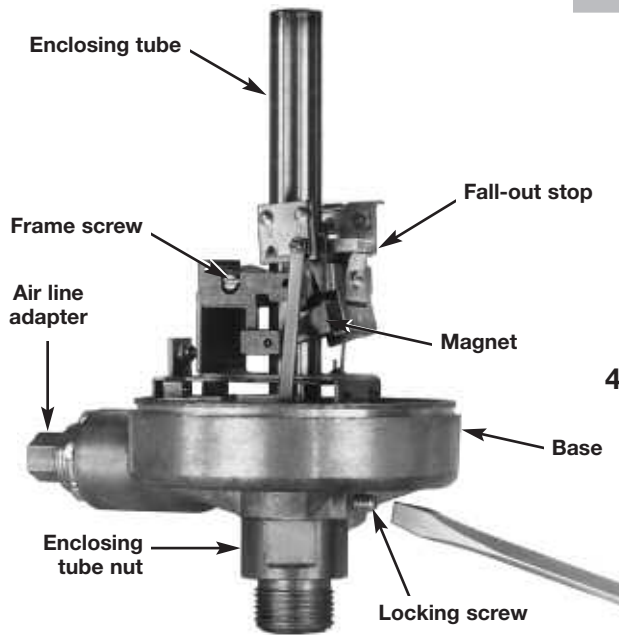

Figure 5

The air line connection may be rotated a full 360° for your convenience in connecting the instrument air supply. To rotate the switch and base assembly:

1. Loosen both the locking screw above the enclosing tube nut and the frame screw. Refer to Figure 5.
2. Rotate the entire base to the desired position.
3. Tighten both the locking screw and the frame screw.

4.0.1 Remove complete mechanism

1. Disconnect air line from air line adapter.
2. Loosen both the locking screw above the enclosing tube nut, and the frame screw approximately 3 to 4 turns. Refer to Figure 5.
3. Lift the entire base and switch assembly straight up and off the enclosing tube.

5.0 Preventive Maintenance

5.0.1 Nozzle cleaning

To clean the nozzle, follow the steps below:

1. Unscrew and remove the adapter. Refer to Figure 6.
2. The o-ring and strainer will now fall out when the switch is tipped.
3. Unscrew the flapper adjustment screw with a 1/16" Allen wrench. This will prevent damage to the flapper when performing step 4.
4. Insert a 1/16" diameter wire into the nozzle from the air line connection side. Refer to Figure 7. The wire may be moved back and forth to clean the opening of any accumulated matter.
5. Reassemble the o-ring, strainer, and air line adapter; insert into nozzle. Refer to Figure 6.
6. Securely tighten the air line adapter.
7. Readjust the flapper to its original position; refer to **Section 5.02 Nozzle flapper readjustment** on page 6.

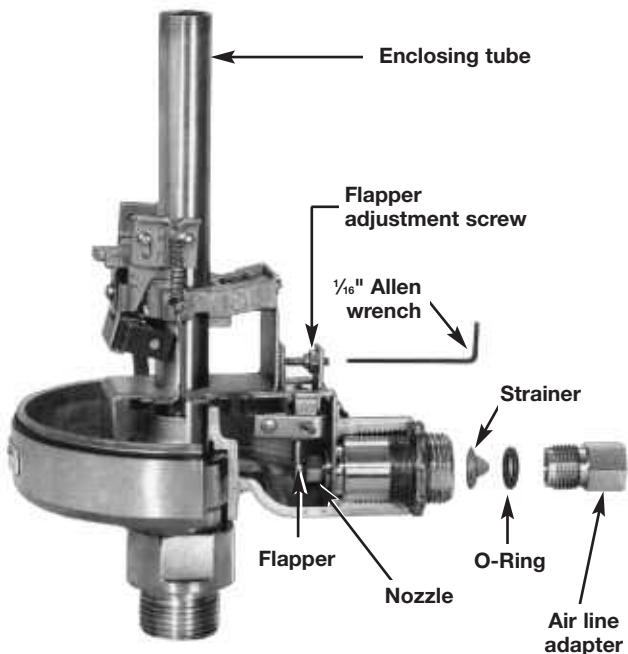

Figure 6

5.0.2 Nozzle flapper readjustment

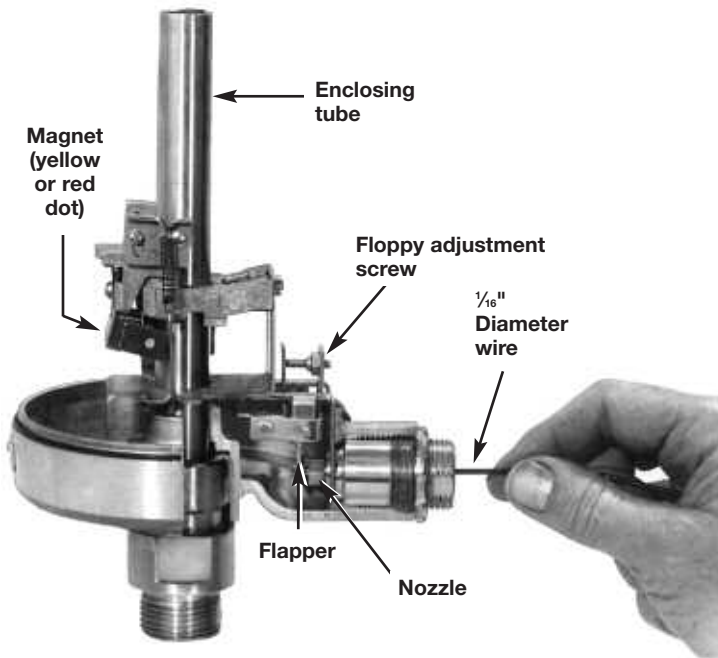

Figure 7

Connect an air line to the adapter.

Adjust the air line.

Turn the flapper adjustment screw for the desired action:

Direct Action

- a. Hold the magnet against the enclosing tube.
- b. Adjust the flapper adjustment screw with a $\frac{1}{16}$ " Allen wrench until the air flow stops, plus an extra one-eighth turn.

Reverse Action

- a. Hold the magnet against the fall out stop. Refer to Figure 5 on page 5.
- b. Adjust the flapper adjustment screw with a $\frac{1}{16}$ " Allen wrench until the air flow stops.
4. Manually actuate the switch under pressure to assure its correct actuation. The unit is now ready for service.

6.0 Replacement Parts

6.1 J Series pneumatic switch

Replacement parts for J Series Pneumatic Switch Mechanisms are available as an assembly only. When ordering an assembly, be certain to specify:

1. The model number of the level control in which the switch was installed, for example B75-1B20-JDE.
2. The serial number of the level control in which the switch was installed. Refer to nameplate attached to control
3. The part number of the replacement switch assembly, for example 89-7501-026.

Description		Part Number
Red Dot	JDG, JGH	89-7501-027
	JEG, JHH	89-7501-029
	JFG, JJH	89-7501-031
Yellow Dot ①	JDE, JGF	89-7501-026
	JEE, JHF	89-7501-028
	JFE, JJF	89-7501-030
Yellow Dot ②	JKE, JNF	89-7501-032
	JLE, JPF	89-7501-033
	JME, JRF	89-7501-034

① For models rated below 1480 psig.

② For models rated above 1480 psig.

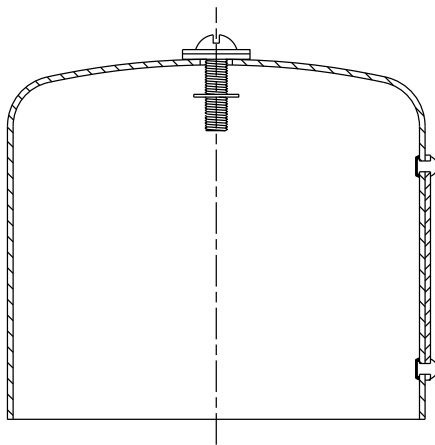

Figure 8

Carbon steel housing assembly

6.2 Switch housing replacement assembly

Standard carbon steel housing replacement assemblies are available. Refer to Figure 8.

Description		Replacement Kit Part Number	
		Gray Cover	Blue Cover
Standard housing cover	Short 4" (102 mm)	89-6523-002	89-6509-003 ①
	Tall 6" (152 mm)	89-6523-001	89-6510-003 ①
Cover assembly hardware		89-6508-001	89-6508-001

① Includes assembly hardware kit 89-6508-001.

7.0 Switch Codes

Magnetrol level controls are identified by an alpha-numeric numbering system. The last digits describe the type of switch mechanism furnished.

SWITCH MECHANISM AND ENCLOSURE

Switch Code			Maximum Supply	Maximum Process Temp.	Orifice Diameter in. (mm)	Cover Height in. (mm)
Red Dot	Yellow Dot					
	①	②				
JDG	JDE	JKE	100 psig (6 bar)	400° F (204° C)	.063 (1)	4 (101)
JEG	JEE	JLE	60 psig (4 bar)	400° F (204° C)	.094 (2)	4 (101)
JFG	JFE	JME	60 psig (4 bar)	700° F (371° C)	.055 (1)	4 (101)
JGH	JGF	JNF	100 psig (6 bar)	400° F (204° C)	.063 (1)	6 (152)
JHH	JHF	JPF	60 psig (4 bar)	400° F (204° C)	.094 (2)	6 (152)
JJH	JJF	JRF	60 psig (4 bar)	700° F (371° C)	.055 (1)	6 (152)

① For models rated below 1480 psig.

② For models rated above 1480 psig.

NOTE: Maximum leakage rate is .5 SCFH at maximum supply pressure.

Example Model Number:

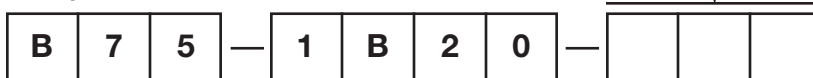

Service Policy

Owners of Magnetrol may request the return of a control or any part of a control for complete rebuilding or replacement. They will be rebuilt or replaced promptly. Controls returned under our service policy must be returned by Prepaid transportation. Magnetrol will repair or replace the control at no cost to the purchaser (or owner) other than transportation if:

1. Returned within the warranty period; and
2. The factory inspection finds the cause of the claim to be covered under the warranty.

If the trouble is the result of conditions beyond our control; or, is NOT covered by the warranty, there will be charges for labor and the parts required to rebuild or replace the equipment.

In some cases it may be expedient to ship replacement parts; or, in extreme cases a complete new control, to replace the original equipment before it is returned. If this is desired, notify the factory of both the model and serial numbers of the control to be replaced. In such cases, credit for the materials returned will be determined on the basis of the applicability of our warranty.

No claims for misapplication, labor, direct or consequential damage will be allowed.

Return Material Procedure

So that we may efficiently process any materials that are returned, it is essential that a "Return Material Authorization" (RMA) number be obtained from the factory, prior to the material's return. This is available through Magnetrol's local representative or by contacting the factory. Please supply the following information:

1. Company Name
2. Description of Material
3. Serial Number
4. Reason for Return
5. Application

Any unit that was used in a process must be properly cleaned in accordance with OSHA standards, before it is returned to the factory.

A Material Safety Data Sheet (MSDS) must accompany material that was used in any media.

All shipments returned to the factory must be by prepaid transportation.

All replacements will be shipped F.O.B. factory.

