

MAXIM

High Speed 12-Bit Monolithic D/A Converters

General Description

The MX565A and MX566A are 12-bit monolithic digital to analog converters (DACs) built in bipolar technology that offer an excellent combination of high speed settling and $\pm 1/4$ LSB linearity. The MX565A also features an on-chip precision 10V reference, whereas the MX566A requires an external reference.

Laser trimming of the on chip thin film resistor networks achieve $\pm 1/4$ LSB typical linearity ($\pm 1/2$ LSB max.) at +25°C. Full scale settling time to $\pm 1/2$ LSB is specified at 250ns max. for the MX565A and 350ns max. for the MX566A. This high speed and accuracy makes the MX565A and MX566A DACs ideal choices for fast analog to digital converters and CRT display drivers.

The MX565A and MX566A contain onboard application resistors that can be used as feedback and offset resistors with an external output amplifier to generate unipolar and bipolar outputs or as the input resistors in analog to digital converter applications. The excellent matching and tracking of the DAC's current setting resistor and application resistors assure good gain stability over both time and temperature.

Applications

High Speed Display Drivers
High Speed Control Systems
High Speed A/D Converters
Data Acquisition Systems
Test Equipment

Features

- ◆ 250ns Settling to $\pm 1/2$ LSB
- ◆ Monotonicity Guaranteed Over Temperature
- ◆ TTL and CMOS Logic Compatibility
- ◆ High Stability Buried Zener 10V Reference (MX565A Only)
- ◆ $\pm 1/4$ LSB Linearity Guaranteed Over Temperature (MX565AK,AT and MX566AK,AT Only)
- ◆ Low Power Consumption: 225mW
- ◆ Widely Second Sourced

Ordering Information

PART	TEMP. RANGE	PACKAGE*	ERROR
MX565AJN	0°C to +70°C	Plastic DIP	$\pm 1/2$ LSB
MX565AJD	0°C to +70°C	Ceramic	$\pm 1/2$ LSB
MX565AJQ	0°C to +70°C	CERDIP**	$\pm 1/2$ LSB
MX565AJCWG	0°C to +70°C	Small Outline	$\pm 1/2$ LSB
MX565AJC/D	0°C to +70°C	Dice	$\pm 1/2$ LSB
MX565AKN	0°C to +70°C	Plastic DIP	$\pm 1/4$ LSB
MX565AKD	0°C to +70°C	Ceramic	$\pm 1/4$ LSB
MX565AKQ	0°C to +70°C	CERDIP**	$\pm 1/4$ LSB
MX565AKCWG	0°C to +70°C	Small Outline	$\pm 1/4$ LSB
MX565ASD	-55°C to +125°C	Ceramic	$\pm 1/2$ LSB
MX565ASQ	-55°C to +125°C	CERDIP**	$\pm 1/2$ LSB
MX565ATD	-55°C to +125°C	Ceramic	$\pm 1/4$ LSB
MX565ATQ	-55°C to +125°C	CERDIP**	$\pm 1/4$ LSB

* All devices — 24 lead packages

** MAXIM reserves the right to ship Ceramic packages in lieu of CERDIP packages.

Ordering information for MX566A continued on back page

Pin Configurations

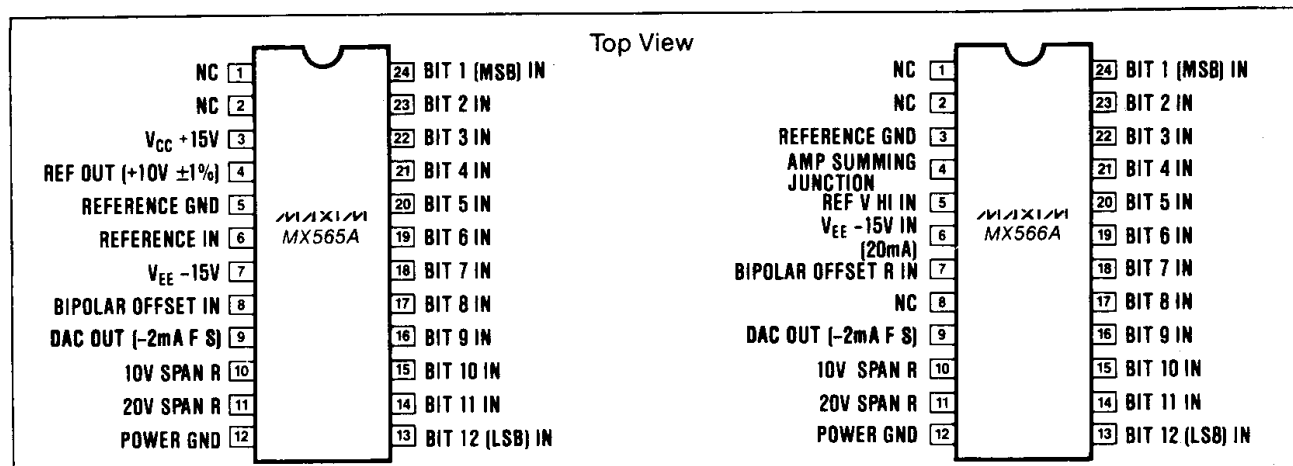

MAXIM

MAXIM is a registered trademark of Maxim Integrated Products

Maxim Integrated Products 2-1

MX565A/MX566A

2

High Speed 12-Bit Monolithic D/A Converters

ABSOLUTE MAXIMUM RATINGS

V _{CC} to Power Ground (MX565A only)	0V to +18V
V _{EE} to Power Ground	0V to -18V
Voltage on DAC Output	-3V to +12V
Digital Inputs (pins 13 to 24) to Power Ground	-1V to +7V
REF IN to Reference Ground	±12V
Bipolar Offset to Reference Ground	±12V
10V Span R to Reference Ground	±12V

20V Span R to Reference Ground	±24V
REF OUT (MX565A only)	
Short Circuit to Power Ground	Continuous
Short to V _{CC}	Momentary
Storage Temperature	-65° C to +150° C
Lead Temperature (Soldering, 10 sec)	+300° C
Package Dissipation	1000mW

Stresses above those listed under "Absolute Maximum Ratings" may cause permanent damage to the device. These are stress ratings only, and functional operation of the device at these or any other conditions above those indicated in the operational sections of the specification is not implied. Exposure to absolute maximum ratings conditions for extended periods may affect the device reliability.

ELECTRICAL CHARACTERISTICS

(T_A = +25° C, V_{CC} = +15V (MX565A only), V_{EE} = -15V, unless noted)

PARAMETER	CONDITIONS	MX565AJ, AS MX566AJ, AS			MX565AK, AT MX566AK, AT			UNITS	
		MIN.	TYP.	MAX.	MIN.	TYP.	MAX.		
Data Inputs (Pins 13 to 24)									
Input Voltage	TTL or 5V CMOS T _{MIN} to T _{MAX} (Note 1)	+2.0		+5.5	+2.0		+5.5	V	
Bit ON Logic "1"		0		+0.8	0		+0.8	V	
Bit OFF Logic "0"									
Logic Current (each bit)				+120	+300		+120	+300	μA
Bit ON Logic "1"				+35	+100		+35	+100	μA
Bit OFF Logic "0"									
Resolution				12			12	Bits	
Output									
Output Current									
Unipolar (all bits on)		-1.6	-2.0	-2.4	-1.6	-2.0	-2.4	mA	
Bipolar (all bits on or off)		±0.8	±1.0	±1.2	±0.8	±1.0	±1.2	mA	
Output Resistance (exclusive of span resistors)			8	10	6	8	10	kΩ	
Output Offset									
Unipolar (adjustable to zero per Fig. 1)			0.01	0.05		0.01	0.05	% of F.S.	
Bipolar (Fig. 2, R ₁ and R ₂ = 50Ω fixed)			0.05	0.15		0.05	0.1	% of F.S.	
Output Capacitance			25			25		pF	
Output Compliance Voltage	T _{MIN} to T _{MAX}	-1.5		+10	-1.5		+10	V	
Accuracy (error relative to full scale)	+25° C		±¼ (0.006)	±½ (0.012)		±¼ (0.003)	±½ (0.006)	LSB	
	T _{MIN} to T _{MAX}		±½ (0.012)	±¾ (0.018)		±¼ (0.006)	±½ (0.012)	(% of F.S.)	
Differential Nonlinearity	+25° C		±½	±¾		±¼	±½	LSB	
	T _{MIN} to T _{MAX}		Monotonicity Guaranteed						
Temperature Coefficients									
MX565A with Internal Reference									
Unipolar Zero			1	2		1	2	ppm/° C	
Bipolar Zero			5	10		5	10		
Gain (Full Scale)									
MX565AJ			15	50		10	20		
MX565AK									
MX565AS			15	30					
MX565AT						10	15		
Differential Nonlinearity			2			2			
MX566A								ppm/° C	
Unipolar Zero			1	2		1	2		
Bipolar Zero			5	10		5	10		
Gain (Full Scale)									
MX566AJ, AS			7	10					
MX566AK, AT						2	3		
Differential Nonlinearity			2			2			

High Speed 12-Bit Monolithic D/A Converters

MX565A/MX566A
ELECTRICAL CHARACTERISTICS (continued)

 (T_A = +25° C, V_{CC} = +15V (MX565A only), V_{EE} = -15V, unless noted)

PARAMETER	CONDITIONS	MX565AJ, AS MX566AJ, AS			MX565AK, AT MX566AK, AT			UNITS	
		MIN.	TYP.	MAX.	MIN.	TYP.	MAX.		
Full Scale Transition 70% to 90% Delay plus Rise Time 90% to 10% Delay plus Full Time	(Note 3)		15 30	30 50		15 30	30 50	ns	
Settling Time to within ±½ LSB All Bits on-to-off or off-to-on	MX565A (Note 3) MX566A (Note 3)		150 250	250 350		150 250	250 350	ns	
Temperature Range (Operating)	AJ, AK AS, AT	0 -55		+70 +125	0 -55		+70 +125	°C	
Power Requirements (MX565A Only)									
+I _{PS} -I _{PS}	11.4V > V _{CC} > 16.5V		3 -12	5 -18		3 -12	5 -18	mA	
+V _{CC} Gain Sensitivity -V _{EE} Gain Sensitivity (Note 2)	11.4V > V _{EE} > 16.5V		3 15	10 25		3 15	10 25	ppm of F.S./%	
Power Requirements (MX566A Only)									
-I _{PS}	11.4V > V _{EE} > 16.5V		-12	-20		-12	-20	mA	
-V _{EE} Gain Sensitivity			15	25		15	25	ppm of F.S./%	
Programmable Output Ranges (MX565A and MX566A)	See Figs. 4.5		0 to +5 -2.5 to +2.5 0 to +10 -5 to +5 -10 to +10			0 to +5 -2.5 to +2.5 0 to +10 -5 to +5 -10 to +10		V	
External Adjustments									
Gain Error with Fixed 50Ω Resistor Bipolar Zero Error with Fixed 50Ω Resistor Gain Adjustment Range Bipolar Zero Adjustment Range	See Figs. 4.5		±0.1 ±0.05 ±0.25 ±0.15	±0.25 ±0.15		±0.1 ±0.05 ±0.25 ±0.15	±0.25 ±0.1	% of F.S.	
Reference Input Impedance			15	20	25	15	20	25	kΩ
Reference Output Voltage (MX565A Only)			9.90	10.00	10.10	9.90	10.00	10.10	V
Reference Output Current (available for external loads) (MX565A Only)			1.5	2.5		1.5	2.5		mA
Power Dissipation (MX565A) MX566A			225 180	345 300		225 180	345 300		mW
Multiplying Mode Performance (MX566A Only)									
Quadrants Reference Voltage Accuracy Reference Feedthrough (unipolar mode, all bits OFF, and 1 to +10V [p-p] sinewave frequency for ½ LSB [p-p] feedthrough) Output Slew Rate 10%-90% 90%-10% Output Settling Time (all bits on and a 0-10V step change in reference voltage)			Two (2): Bipolar Operation at Digital Input Only +1V to +10V, Unipolar 10 Bits (±0.05% of Reduced F.S.) for 1V DC Reference Voltage 40kHz typ 5mA/μs 1mA/μs 1.5μs to 0.01% F.S.						
Control Amplifier (MX566A)									
Full Power Bandwidth Small-Signal Closed-Loop Bandwidth			300kHz 1.8MHz						

Note 1: The digital input levels are guaranteed but not tested over the temperature range.

Note 2: The power supply gain sensitivity is tested in reference to a V_{CC} of +15V and V_{EE} of -15V d.c.

Note 3: Sample tested at +25°C to ensure compliance.

2-3

High Speed 12-Bit Monolithic D/A Converters

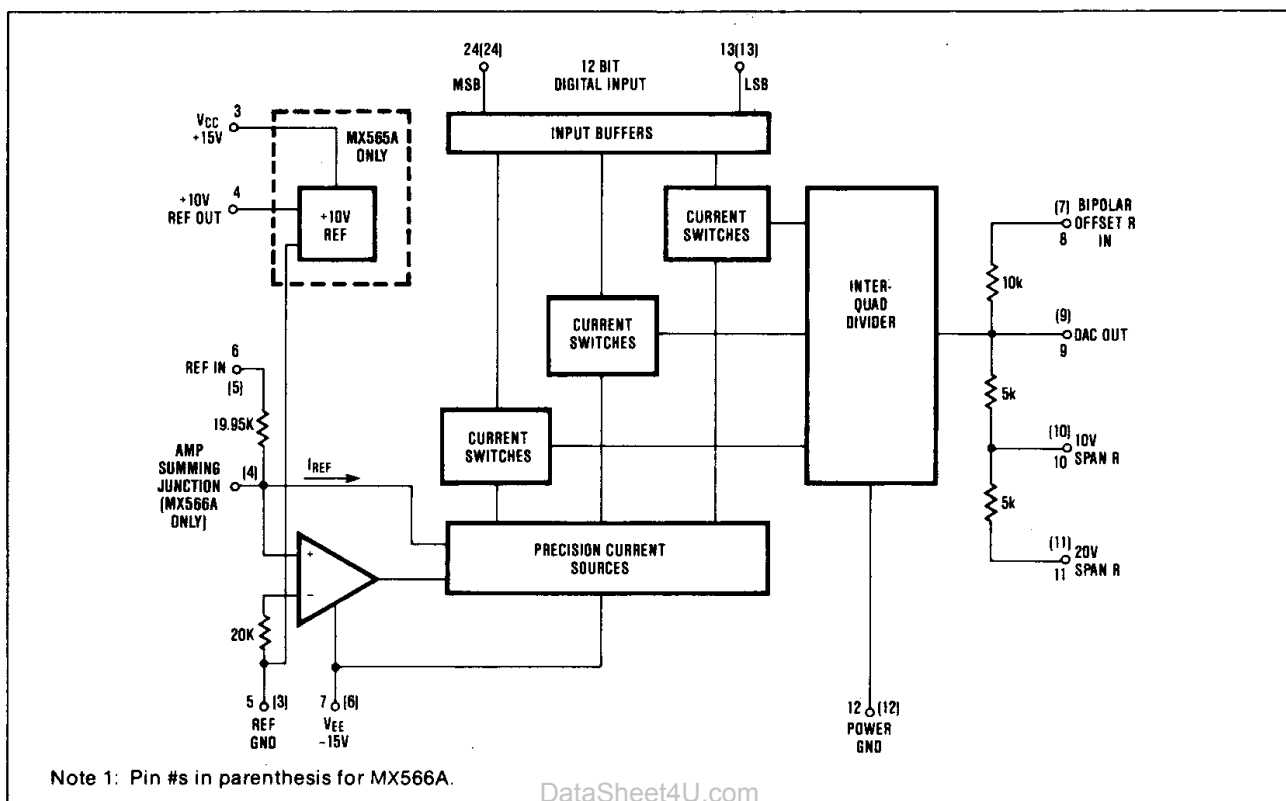

Figure 1. Functional Block Diagram

Circuit Description

The MX565A and MX566A are 12-bit precision DACs that consist of three binary weighted quad current sources with 16:1 interquad current dividers (see figure 1). Each quad has four current switches with 8-4-2-1 current weighting ratios. The current switches are optimized for fast switching and low transient glitches at the output of the DAC during input code changes.

Full scale accuracy of the DACs are maintained over temperature and time by the DAC control amplifier that includes a current switch reference device that implements first order correction for resistor, transistor V_{BE} and beta changes with temperature so that the only remaining errors are those that are induced by component mismatch.

The MX565A has a buried zener diode that is used for the on chip 10V voltage reference. In the feedback of the reference amplifier is a temperature compensation circuit that allows reference temperature coefficients as low as 10ppm/ $^{\circ}$ C to be achieved. The 10V output of the voltage reference is laser trimmed to within ± 10 mV.

Application Hints

To realize the true performance of the MX565A and MX566A special attention must be taken in the application of the device.

The settling time of the DAC is specified in the current output mode. However, most DAC applications require a current to voltage conversion. The simplest, and fastest voltage conversion technique is achieved by connecting a low value resistor directly between the output and ground (see figure 2). The settling time is a function of the cell switching and the RC time constant of the MX565A and MX566A output capacitance (typically 25pF) plus any stray capacitance, and the value of the output resistor. Settling to 0.01% ($\frac{1}{2}$ LSB) of full scale for a full scale change requires 9.1 time constants. The effect of the external resistor becomes important when the equivalent resistance at the output of the DAC is over 1k Ω .

The wide compliance voltages of the MX565A and MX566A allow direct current to voltage conversion with just an output resistor. Connecting the internal gain (span) resistors (pins 10 and 11) to ground and the bipolar offset resistor to the internal 10V reference on the MX565A and an external 10V reference for the MX566A, a bipolar output voltage swing of ± 1.60 V

High Speed 12-Bit Monolithic D/A Converters

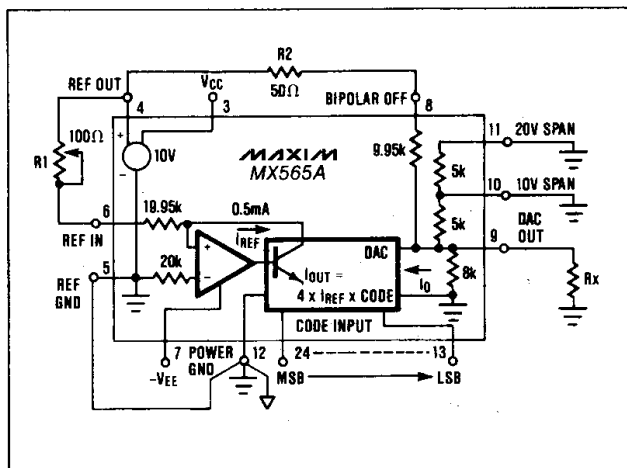

Figure 2. Unbuffered Bipolar Voltage Output

can be generated. Other combinations of external and the internal resistors can scale the full scale output current of 0 to -2mA to any voltage as long as this voltage stays within the compliance voltage of the MX565A and MX566A, which is typically -2V to $+10\text{V}$. For example, setting the $R_x = 2.67\text{k}\Omega$ produces an equivalent impedance of $1\text{k}\Omega$ giving a $\pm 1\text{V}$ output voltage swing.

The output voltage compliance of typically -2V to $+10\text{V}$ allows the performance of the DAC to be unaffected by changes in the output terminal voltage. There is however, an equivalent output resistance of $8\text{k}\Omega$ in parallel with 25pF which produces an equivalent current error when the output voltage deviates from ground. This effect is linear and is independent of the digital input code. Output swings outside the compliance range can cause either output stage saturation or breakdown which may result in non-linear performance. The compliance limits are affected only by the output current and the negative supply voltage. The positive supply voltage has no effect. Figure 3 shows the typical negative compliance versus the negative supply voltage.

The current output of the DAC can directly drive 50Ω and 75Ω coaxial cable. Terminating the cable in its characteristic impedance would produce a $\pm 50\text{mV}$ full scale swing for the 50Ω and $\pm 75\text{mV}$ for the 75Ω cable. The settling times are dominated by the internal settling of the MX565A and MX566A.

The high speed current steering switching cell and internally compensated reference amplifier of the MX565A and MX566A have been specifically designed for fast settling. The typical settling time to $\pm 0.01\%$ ($\frac{1}{2}\text{LSB}$) for the major carry or full scale change (worst case transition) is about 200ns ; the lower order bits all settle in less than 200ns . The maximum guaranteed settling time to 0.01% ($\pm \frac{1}{2}\text{LSB}$) for the MX565A is 250ns and 350ns for the MX566A.

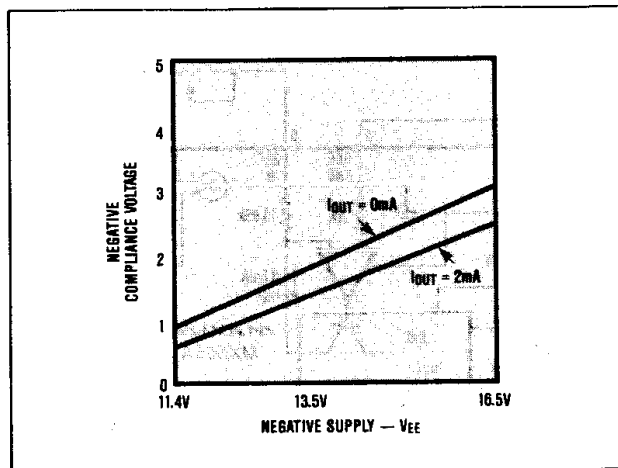

Figure 3. Typical Negative Compliance Range vs. Negative Supply

Buffered Voltage Output

If an external op-amp is used to provide low impedance output drive and high voltage swing, some loss in settling time will occur due to the op-amp's own settling characteristics. In these applications the DAC's output capacitance should be compensated by a feedback capacitor connected across the amplifier's output and inverting input as shown in figures 4 and 5.

If a low offset amplifier such as the MAX400M ($10\mu\text{V}$ max.) or MAX400C ($15\mu\text{V}$ max.) is used, excellent performance can be obtained without any trimming. Figures 4(a), 4(b), and 4(c) show how to connect the MX565A for both unipolar and bipolar voltage outputs. The connections for the MX566A are shown in figures 5(a), 5(b), and 5(c). The preferred trimming techniques are shown for both offset and gain adjustments if required. Substituting a fixed 50Ω resistor in place of the 100Ω potentiometers, the unipolar zero offset error will be within $\pm \frac{1}{2}\text{LSB}$ (plus op-amp offset), and full scale accuracy will be within 0.1% (0.25% max.). Similarly, the bipolar zero offset error will be typically within $\pm 2\text{LSB}$ (0.05%).

Unipolar configuration zero and gain adjustment

Figures 4(a) and 5(a) show the configurations for a unipolar 0 to $+10\text{V}$ output. The bipolar offset resistor is tied to ground if zero offset adjustment is not required.

Turn all bits OFF and adjust potentiometer R1 until DAC output reads 0.000V ($1\text{LSB} = 2.44\text{mV}$). If offset adjust is not required tie pin 8 to ground.

Next, turn all bits ON and adjust gain potentiometer R2 until DAC output reads 9.9976V (full scale -1LSB). If full scale of 10.2400V is required ($2.5\text{mV}/\text{bit}$) then insert a 120Ω resistor between op-amp output and pin 10 (10V span resistor).

High Speed 12-Bit Monolithic D/A Converters

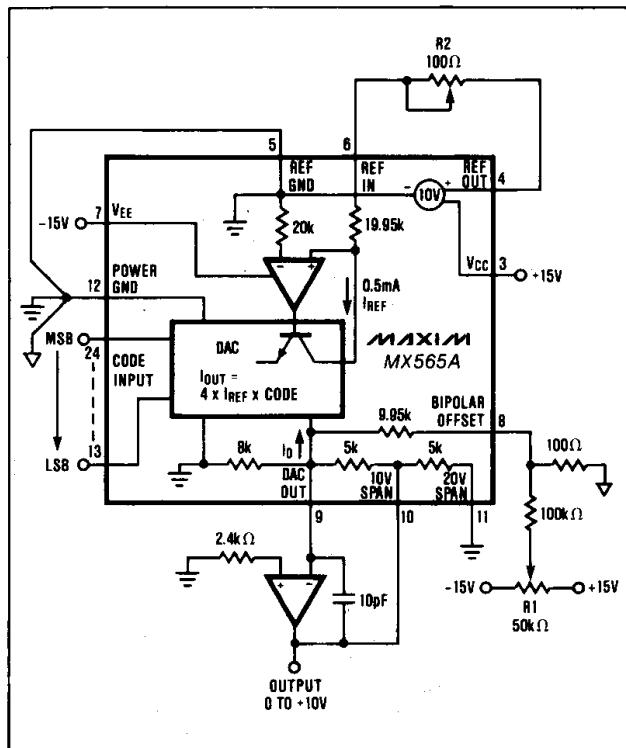

Figure 4(a). MX565A 0 to +10V Unipolar Voltage Output

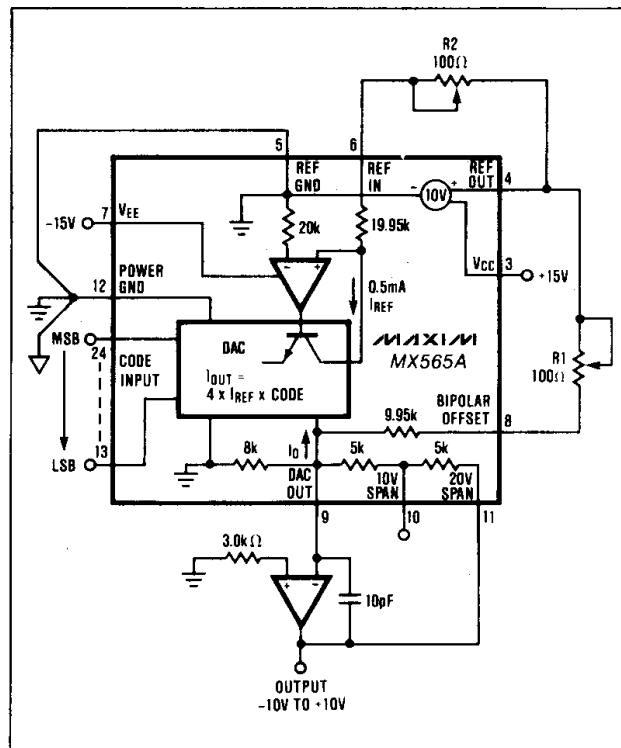

Figure 4(c). MX565A ±10V Bipolar Voltage Output

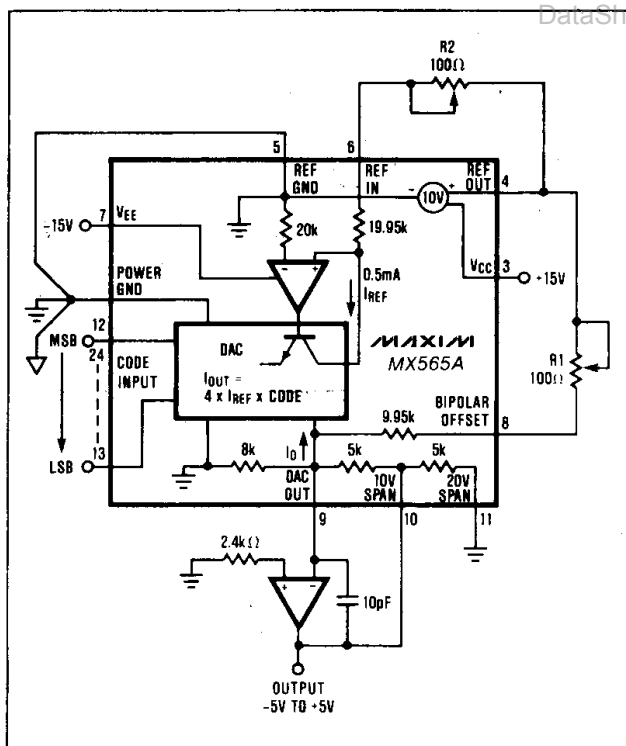

Figure 4(b). MX565A ±5V Bipolar Voltage Output

Bipolar configuration offset and gain adjustment

Figures 4(b) and 5(b) show how to configure the DAC to produce an output from -5.000V (all 0's) to +4.9976V (all 1's).

First turn OFF all bits, adjust potentiometer R1 to give -5.000V output.

Then turn all bits ON. Adjust potentiometer R2 to give a DAC output of +4.9976V.

Other voltage ranges

The MX565A and MX566A can easily be configured for unipolar 0 to +5V range or ±2.5V and ±10V bipolar ranges by using the 20V span resistor (pin 11). Connecting pin 9 and 11 together a 5V span can be developed by connecting pin 10 to the output of the op-amp and the bipolar offset resistor to either ground for the unipolar 0 to +5V range or to REF OUT for the bipolar ±2.5V range. For the ±10V (20V span) connect pin 11 to the op-amp output and the bipolar offset resistor to potentiometer R1 as shown in figures 4(c) and 5(c).

High Speed 12-Bit Monolithic D/A Converters

MX565A/MX566A

2

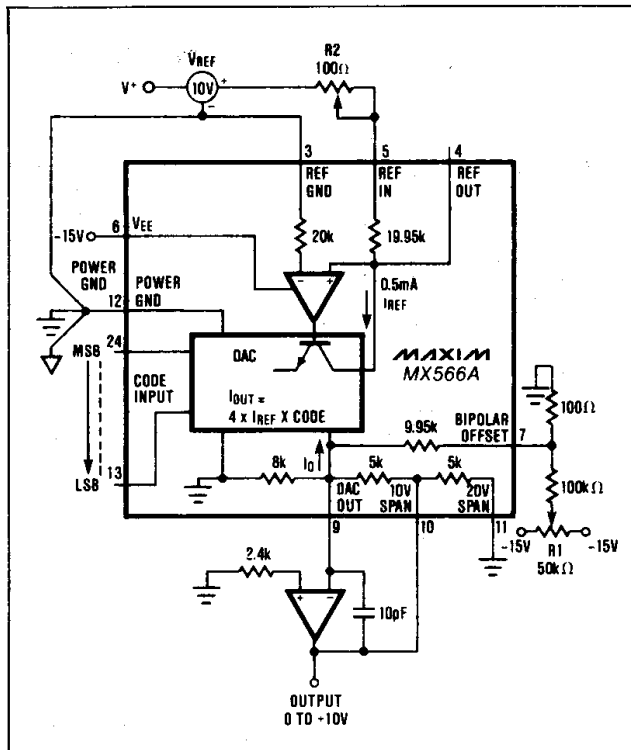

Figure 5(a). MX566A 0 to +10V Unipolar Voltage Output

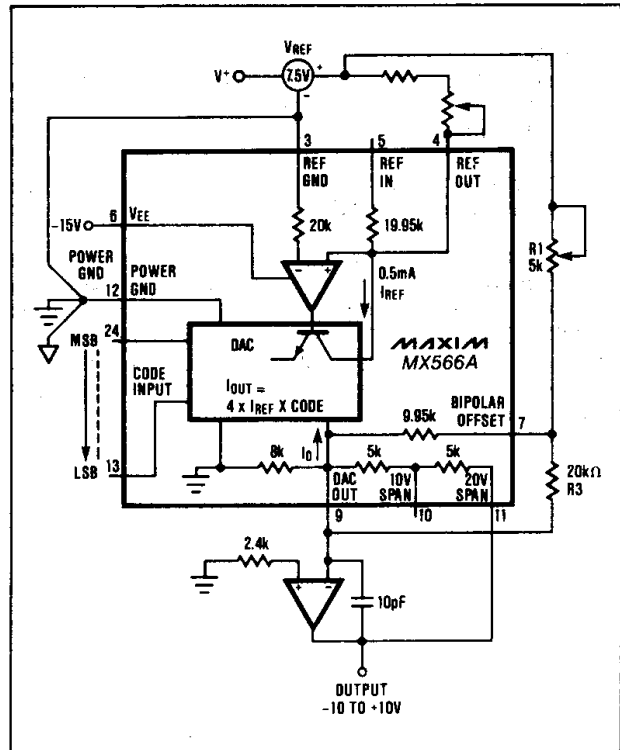

Figure 5(c). MX566A ±10V Bipolar Voltage Output

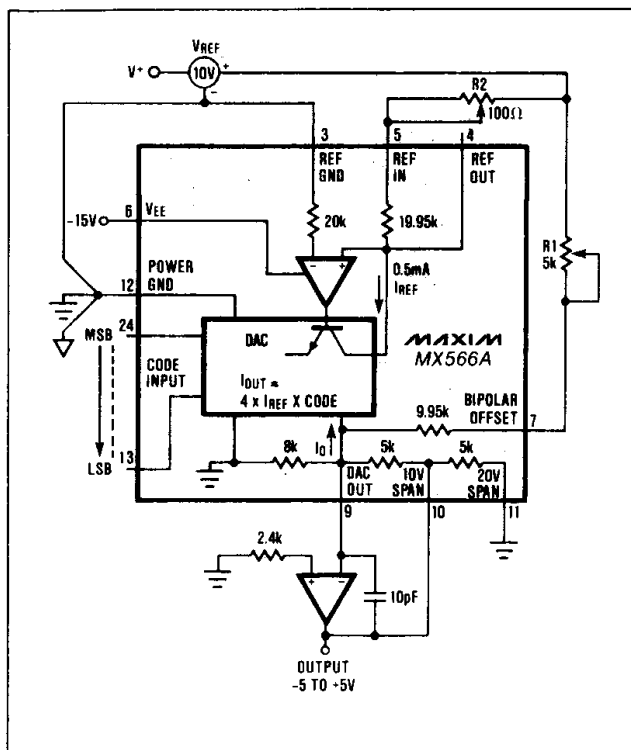

Figure 5(b). MX566A ±5V Bipolar Voltage Output

Grounding

The MX565A and MX566A have two ground pins, Reference GND and Power GND. The current in the power ground varies with the digital input code and should be connected to the local ground, digital ground or power ground. The reference ground is the ground point for the internal reference amplifier and should be connected to the system's "high quality" ground, usually called signal or analog ground.

Internal/External Reference Use

The MX565A has an internal reference whereas the MX566A requires an external reference. The MX565A can be used with either the internal reference or an external reference. With an external 10V reference there may not be enough adjustment range to accommodate a reference that does not match the internal reference voltage. The MX566A is recommended for applications that need to be driven with an external reference.

The internal reference of the MX565A is a low noise buried zener diode that is buffered by an internal amplifier whose gain is trimmed for absolute accuracy and temperature stability. The performance of the MX565A DAC is tested and specified using the internal reference.

MAXIM

2-7

High Speed 12-Bit Monolithic D/A Converters

In addition, the internal reference of the MX565A has sufficient buffering to drive the internal DAC (typically 0.5mA to REF IN and 1.0mA to Bipolar Offset, if used) plus an additional 1.5mA for driving external circuits. The temperature coefficient of the reference output voltage is comparable to the DAC's full scale TC for the particular grade of MX565A.

For the MX566A an external reference is required that should have a low temperature coefficient, such as the MX581, MX584, or precision references such as the MX2700 and MX2710. For the ultimate in performance use the MAX670 and MAX671, which have kelvin sense connections for both the +10V reference output and ground return.

Ordering Information (continued)

PART	TEMP. RANGE	PACKAGE*	ERROR
MX566AJN	0°C to +70°C	Plastic DIP	±½LSB
MX566AJD	0°C to +70°C	Ceramic	±½LSB
MX566AJQ	0°C to +70°C	CERDIP**	±½LSB
MX566AJCWG	0°C to +70°C	Small Outline	±½LSB
MX566AKN	0°C to +70°C	Plastic DIP	±¼LSB
MX566AKD	0°C to +70°C	Ceramic	±¼LSB
MX566AKQ	0°C to +70°C	CERDIP**	±¼LSB
MX566AKCWG	0°C to +70°C	Small Outline	±¼LSB
MX566ASD	-55°C to +125°C	Ceramic	±½LSB
MX566ASQ	-55°C to +125°C	CERDIP**	±½LSB
MX566ATD	-55°C to +125°C	Ceramic	±¼LSB
MX566ATQ	-55°C to +125°C	CERDIP**	±¼LSB

* All devices — 24 lead packages

** MAXIM reserves the right to ship Ceramic packages in lieu of CERDIP packages.

Chip Topography

MX565A

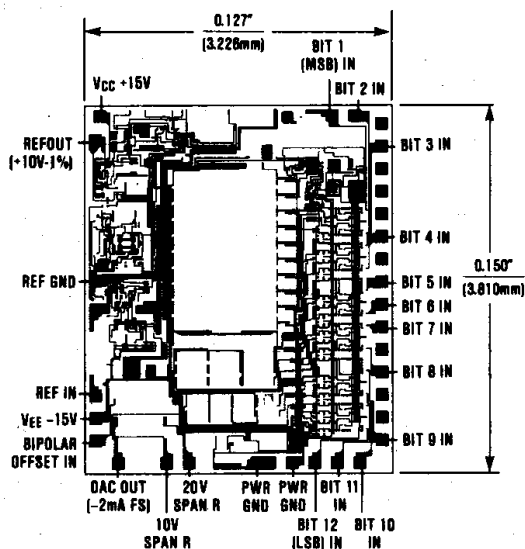

DataSheet4U.MX566A

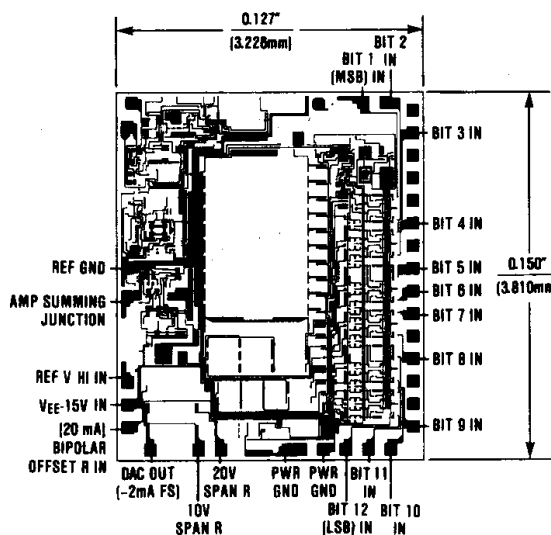

Maxim cannot assume responsibility for use of any circuitry other than circuitry entirely embodied in a Maxim product. No circuit patent licenses are implied. Maxim reserves the right to change the circuitry and specifications without notice at any time.