



AUDIO PROCESSOR with Multipurpose Surround Sound System and Input Selector

■ GENERAL DESCRIPTION

The **NJW1190** is a sound processor with Multipurpose Surround Sound system includes all of functions processing audio signal for Mini-Component and TV, such as input selector, tone control, balance, volume, and mute functions.

Also the **NJW1190** includes the 5 types of surround sound and Bass Boost function. Their combination reproduces a number of sound effects.

NJW1190 performs low noise and low distortion characteristics with resistance ladder type electrical volume. All of internal status and variables are controlled by I²C BUS interface.

■ PACKAGE OUTLINE



NJW1190V

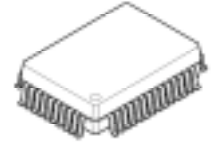

NJW1190FP1

■ FEATURES

- Operating Voltage 8 to 13V
- I²C BUS Interface
- Low Output Noise -100dBV typ
- Low Distortion 0.005% typ
- 5ch Input Selector
- Monaural Microphone Input
- Input Gain Setting 0 to +14dB
- Tone Control Bass / Middle / Treble
- 5 types of Surround Sound
- Bi-CMOS Technology
- Package Outline SSOP44, QFP48-P1

■ BLOCK DIAGRAM

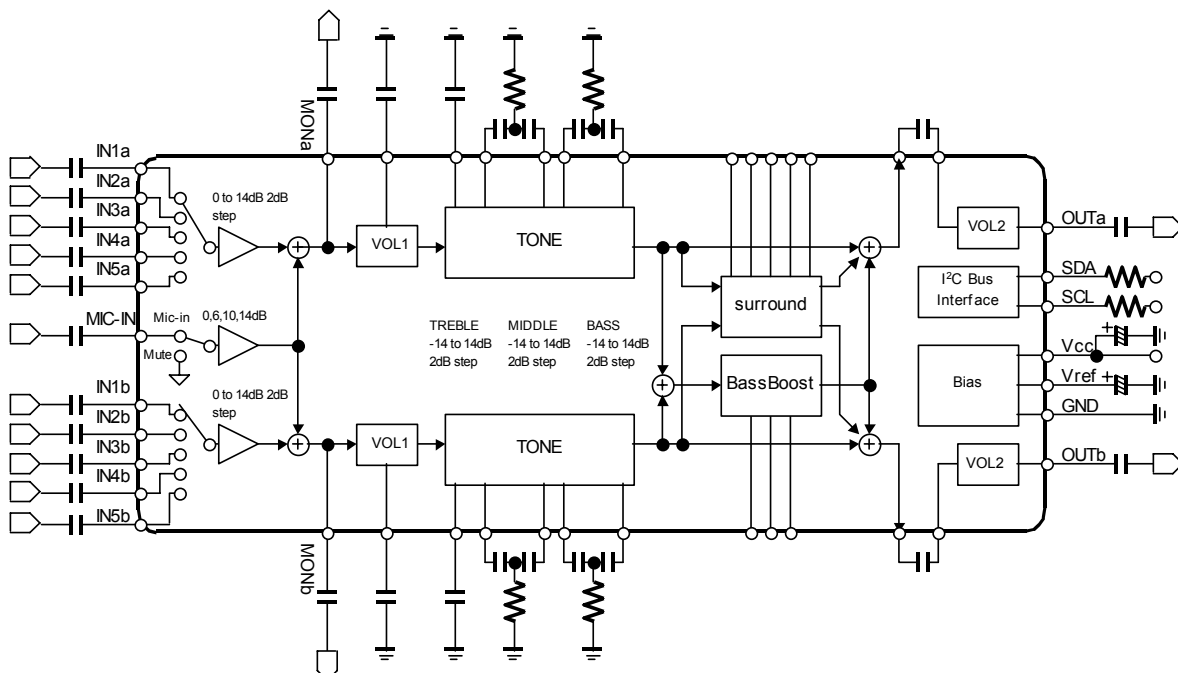

■ PIN FUNCTION (SSOP44)

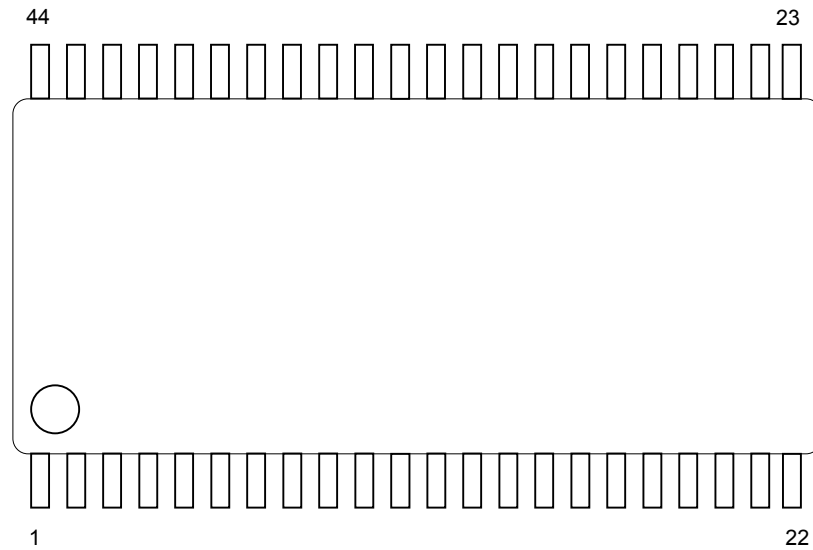

No.	SYMBOL	FUNCTION	No.	SYMBOL	FUNCTION
1	MIC-IN	Microphone Input	23	SDA	SDA Data Input (I ² C BUS)
2	SRFil1	Surround Filter1	24	V ⁺	Power Supply Pin
3	SRFil2	Surround Filter2	25	OUTb	Bch Output
4	VEFil1	Voice Enhancement Filter1	26	VOL2INb	Bch Volume2 Input
5	VEFil2	Voice Enhancement Filter2	27	SROUTb	Bch Surround Output
6	IN1a	Ach Input1	28	TONE-L2b	Bch Bass Filter2
7	IN2a	Ach Input2	29	TONE-L1b	Bch Bass Filter1
8	IN3a	Ach Input3	30	TONE-M2b	Bch Middle Filter2
9	IN4a	Ach Input4	31	TONE-M1b	Bch Middle Filter1
10	IN5a	Ach Input5	32	TONE-Hb	Bch Treble Filter
11	MONOUTa	Ach Monitor Output	33	VOL1-DCb	Bch Volume1 Switching Noise Rejection Capacitor
12	VOL1-DCa	Ach Volume1 Switching Noise Rejection Capacitor	34	MONOUTb	Bch Monitor Output
13	TONE-Ha	Ach Treble Filter	35	IN5b	Bch Input5
14	TONE-M1a	Ach Middle Filter1	36	IN4b	Bch Input4
15	TONE-M2a	Ach Middle Filter2	37	IN3b	Bch Input3
16	TONE-L1a	Ach Bass Filter1	38	IN2b	Bch Input2
17	TONE-L2a	Ach Bass Filter2	39	IN1b	Bch Input1
18	SROUTa	Ach Surround Output	40	BBFil3	Bass Boost Filter3
19	VOL2INa	Ach Volume2 Input	41	BBFil2	Bass Boost Filter2
20	OUTa	Ach Output	42	BBFil1	Bass Boost Filter1
21	GND	GND	43	PSFil	Phase Shifter Filter
22	SCL	SCL Data Input (I ² C BUS)	44	Vref	Reference Voltage

■ PIN FUNCTION (QFP48-P1)

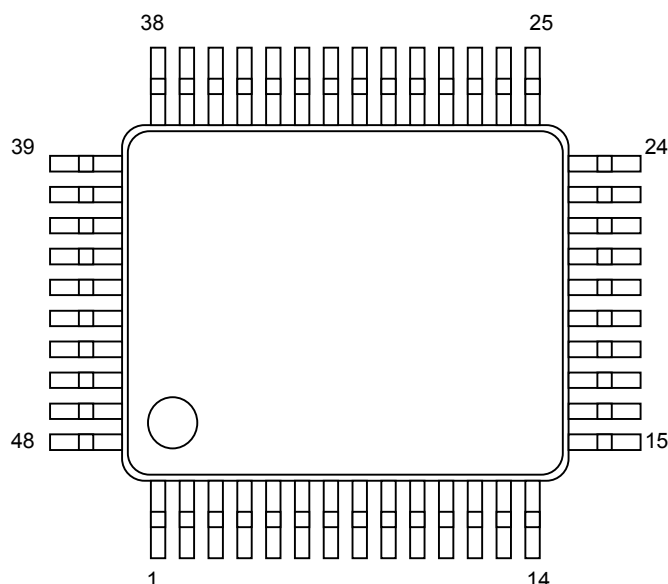

No.	SYMBOL	FUNCTION	No.	SYMBOL	FUNCTION
1	N.C.	No Connection	25	N.C.	No Connection
2	IN1a	Ach Input1	26	TONE-L2b	Bch Bass Filter2
3	IN2a	Ach Input2	27	TONE-L1b	Bch Bass Filter1
4	IN3a	Ach Input3	28	TONE-M2b	Bch Middle Filter2
5	IN4a	Ach Input4	29	TONE-M1b	Bch Middle Filter1
6	IN5a	Ach Input5	30	TONE-Hb	Bch Treble Filter
7	MONOUTa	Ach Monitor Output	31	VOL1-DCb	Bch Volume1 Switching Noise Rejection Capacitor
8	VOL1-DCa	Ach Volume1 Switching Noise Rejection Capacitor	32	MONOUTb	Bch Monitor Output
9	TONE-Ha	Ach Treble Filter	33	IN5b	Bch Input5
10	TONE-M1a	Ach Middle Filter1	34	IN4b	Bch Input4
11	TONE-M2a	Ach Middle Filter2	35	IN3b	Bch Input3
12	TONE-L1a	Ach Bass Filter1	36	IN2b	Bch Input2
13	TONE-L2a	Ach Bass Filter2	37	IN1b	Bch Input1
14	N.C.	No Connection	38	N.C.	No Connection
15	SROUTa	Ach Surround Output	39	BBFil3	Bass Boost Filter3
16	VOL2INa	Ach Volume2 Input	40	BBFil2	Bass Boost Filter2
17	OUTa	Ach Output	41	BBFil1	Bass Boost Filter1
18	GND	GND	42	PSFil	Phase Shifter Filter
19	SCL	SCL Data Input (I ² C BUS)	43	Vref	Reference Voltage
20	SDA	SDA Data Input (I ² C BUS)	44	MIC-IN	Microphone Input
21	V ⁺	Power Supply Pin	45	SRFil1	Surround Filter1
22	OUTb	Bch Output	46	SRFil2	Surround Filter2
23	VOL2INb	Bch Volume2 Input	47	VEFil1	Voice Enhancement Filter1
24	SROUTb	Bch Surround Output	48	VEFil2	Voice Enhancement Filter2

■ ABSOLUTE MAXIMUM RATING (Ta=25°C)

PARAMETER	SYMBOL	RATING	UNIT
Supply Voltage	V ⁺	15	V
Power Dissipation	P _D	800 (SSOP44)	mW
		1500 (QFP48-P1) (Note)	
Operating Temperature Range	Topr	-20 to +75	°C
Storage Temperature Range	Tstg	-40 to +125	°C

(Note) At on a board of EIA/JEDEC specification. (76.2 × 114.3 × 1.6mm Two layers, FR-4)

■ ELECTRICAL CHARACTERISTICS

(Ta=25°C, V+=9V, R_L=47kΩ, Vin=100mVrms/1kHz, all controls flat(Gv=0dB) unless otherwise specified)

PARAMETER	SYMBOL	Condition	MIN.	TYP.	MAX.	UNIT
Operating Voltage	V ⁺		8.0	9.0	13.0	V
Supply Current	I _{CC}	No Signal	-	20	40	mA
Reference Voltage	V _{REF}	No Signal	4.0	4.5	5.0	V
Maximum Input Voltage	V _{IM}	VOL1=-20dB, VOL2A/VOL2B=0dB, THD=10%	2.8	3.0	-	Vrms
Maximum Output Voltage	V _{OM}	OUTPUT VOL1/VOL2A/VOL2B=0dB, THD=1%	-	2.5	-	Vrms
Maximum Monitor Output Gain	G _{VMOMAX}	MON OUT, GVIN="111"	-	14.0	-	dB
Minimum Monitor Output Gain	G _{VMOMIN}	MON OUT, GVIN="000"	-1.0	0.0	1.0	dB
Maximum Mic input Gain	G _{VMICMAX}	MIC-IN, MON OUT, MICGV="11"	-	14.0	-	dB
Minimum Mic input Gain	G _{VICOMIN}	MIC-IN, MON OUT, MICGV="00"	-	0.0	-	dB
Channel Balance	G _{CB}	VOL1/VOL2A/VOL2B=0dB	-1.0	0.0	1.0	dB
Total Harmonic Distortion	THD	Vo=0.5Vrms, BW=400Hz to 30kHz	-	0.005	0.05	%
Maximum Gain	G _{VMAX}	VOL1/VOL2A/VOL2B=0dB	-1.0	0.0	1.0	dB
Minimum Gain	G _{VMIN}	VOL1/VOL2A/VOL2B=MUTE	-	-	-90	dB
Cross Talk	CT	Vin=1Vrms BW=400Hz to 30kHz Selected Input : Rg=0Ω Unselected Inputs : Signal	-	-	-70	dB
Channel Separation	CS	Vin = 1Vrms	-	-	-70	dB
Output Noise Voltage 1	V _{NO1}	VOL1/VOL2A/VOL2B=0dB A-weighted	-	-100 (10)	-	dBV (μVrms)
Output Noise Voltage 2	V _{NO2}	VOL1/VOL2A/VOL2B=MUTE A-weighted	-	-106 (5.0)	-96 (15.8)	dBV (μVrms)

BW : Band Width

■ ELECTRICAL CHARACTERISTICS

(Ta=25°C, V+=9V, RL=47kΩ, Vin=100mVrms/1kHz, all controls flat(Gv=0dB) unless otherwise specified)

◆TONE

PARAMETER	SYMBOL	Condition	MIN.	TYP.	MAX.	UNIT
High Frequency Boost	HF _{BST}	BCT="1",TREB="111", f=10kHz	11.5	14.0	16.5	dB
High Frequency Flat	HF _{FLT}	TREB="000",f=10kHz	-2.0	0.0	2.0	dB
High Frequency Cut	HF _{CUT}	BCT="0",TREB="111", f=10kHz	-16.5	-14.0	-11.5	dB
Middle Frequency Boost	MF _{BST}	BCM="1",MIDD="111", f=1kHz	11.5	14.0	16.5	dB
Middle Frequency Flat	MF _{FLT}	MIDD="000",f=1kHz	-2.0	0.0	2.0	dB
Middle Frequency Cut	MF _{CUT}	BCM="0",MIDD="111", f=1kHz	-16.5	-14.0	-11.5	dB
Low Frequency Boost	LF _{BST}	BCB="1",BASS="111", f=100Hz	11.5	14.0	16.5	dB
Low Frequency Flat	LF _{FLT}	BASS="000",f=100Hz	-2.0	0.0	2.0	dB
Low Frequency Cut	LF _{CUT}	BCB="0",BASS="111", f=100Hz	-16.5	-14.0	-11.5	dB

◆SURROUND

PARAMETER	SYMBOL	Condition	MIN.	TYP.	MAX.	UNIT
Surround Gain1	SR _{GAIN1}	SUR="001", f=100Hz, Ain → Aout	6.3	8.3	10.3	dB
Surround Gain2	SR _{GAIN2}	SUR="001", f=100Hz, Ain → Bout	2.1	4.1	6.1	dB
Surround Gain3	SR _{GAIN3}	SUR="010", f=100Hz, Ain → Aout	10.7	12.7	14.7	dB
Surround Gain4	SR _{GAIN4}	SUR="010", f=100Hz, Ain → Bout	8.4	10.4	12.4	dB
Surround Gain5	SR _{GAIN5}	SUR="011", f=5kHz, A+Bin → Aout	8.0	10.0	12.0	dB

◆Bass Boost

PARAMETER	SYMBOL	Condition	MIN.	TYP.	MAX.	UNIT
Bass Boost Gain1	BB _{GAIN1}	BB="01", f=60Hz, A+Bin → Aout	-	18.0	-	dB
Bass Boost Gain2	BB _{GAIN2}	BB="10", f=60Hz, A+Bin → Aout	-	24.0	-	dB
Bass Boost Gain3	BB _{GAIN3}	BB="11", f=60Hz, A+Bin → Aout	-	29.0	-	dB

■ I²C BUS BLOCK CHARACTERISTICS (SDA,SCL)

PARAMETER	SYMBOL	MIN.	TYP.	MAX.	UNIT
High Level Input Voltage	V _{IH}	2.5	-	5.0	V
Low Level Input Voltage	V _{IL}	0	-	1.5	V
High Level Input Current	I _{IH}	-	-	10	μA
Low Level Input Current	I _{IL}	-	-	10	μA
Low Level Output Voltage (3mA at SDA pin)	V _{OL}	0	-	0.4	V
Maximum Output Current	I _{OL}	-3.0	-	-	mA
Maximum Clock Frequency	f _{SCL}	-	-	100	kHz
Data Change Minimum Waiting Time	t _{BUF}	4.7	-	-	μs
Data Transfer Start Minimum Waiting Time	t _{HD:STA}	4.0	-	-	μs
Low Level Clock Pulse Width	t _{LOW}	4.7	-	-	μs
High Level Clock Pulse Width	t _{HIGH}	4.0	-	-	μs
Minimum Start Preparation Waiting Time	t _{SU:STA}	4.7	-	-	μs
Minimum Data Hold Time	t _{HD:DAT}	0	-	3.45	μs
Minimum Data Preparation Time	t _{SU:DAT}	250	-	-	ns
Rise Time	t _R	-	-	1.0	μs
Fall Time	t _F	-	-	300	ns
Minimum Stop Preparation Waiting Time	t _{SU:STO}	4.0	-	-	μs

I²C BUS Load Condition: Pull up resistance 4kΩ (Connected to +5V)
Load capacitance 200pF (Connected to GND)

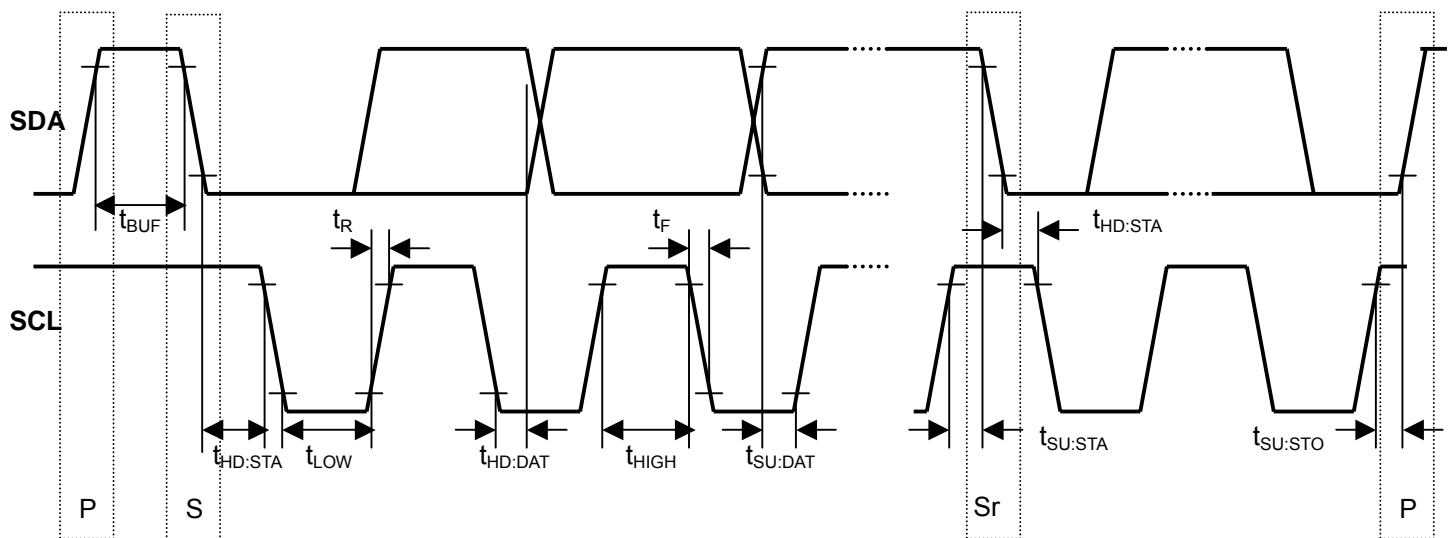

■TERMINAL DESCRIPTION

No.		SYMBOL	FUNCTION	EQUIVALENT CIRCUIT	VOLTAGE
SSOP	QFP				
1	44	MIC-IN	Microphone Input		$V^+/2$
2 3 5 43	45 46 48 42	SRFi1 SRFi2 VEFi2 PSFi1	Surround Filter 1 Surround Filter 2 Voice Enhancement Filter2 Phase Shifter Filter		$V^+/2$
4	47	VEFi1	Voice Enhancement Filter1		$V^+/2$
6 7 8 9 10 35 36 37 38 39	2 3 4 5 6 33 34 35 36 37	IN1a IN2a IN3a IN4a IN5a IN5b IN4b IN3b IN2b IN1b	Ach Input 1 Ach Input 2 Ach Input 3 Ach Input 4 Ach Input 5 Bch Input 5 Bch Input 4 Bch Input 3 Bch Input 2 Bch Input 1		$V^+/2$
11 18 20 25 27 34	7 15 17 22 24 32	MONOUTa SROUTa OUTa OUTb SROUTb MONOUTb	Ach Monitor Output Ach Surround Output Ach Output Bch Output Bch Surround Output Bch Monitor Output		$V^+/2$

■TERMINAL DESCRIPTION

No.		SYMBOL	FUNCTION	EQUIVALENT CIRCUIT	VOLTAGE
SSOP	QFP				
12	8	VOL1-DCa	Ach Volume1 Switching Noise Rejection Capacitor	<p>36k (PIN.8,31) 26k (PIN.9,30) 34k (PIN.11,28) 36k (PIN.13,26) * : QFP PIN No.</p>	V ⁺ /2
13	9	TONE-Ha	Ach Treble Filter		
15	11	TONE-M2a	Ach Middle Filter 2		
17	13	TONE-L2a	Ach Bass Filter 2		
28	26	TONE-L2b	Bch Bass Filter 2		
30	28	TONE-M2b	Bch Middle Filter 2		
32	30	TONE-Hb	Bch Treble Filter		
33	31	VOL1-DCb	Bch Volume1 Switching Noise Rejection Capacitor		
14	10	TONE-M1a	Ach Middle Filter 1		V ⁺ /2
16	12	TONE-L1a	Ach Bass Filter 1		
29	27	TONE-L1b	Bch Bass Filter 1		
31	29	TONE-M1b	Bch Middle Filter 1		
40	39	BBFi3	Bass Boost Filter 3		
19	16	VOL2INa	Ach Volume2 Input		V ⁺ /2
26	23	VOL2INb	Bch Volume2 Input		
22	19	SCL	SCL Data Input (I ² C BUS)		-
23	20	SDA	SDA Data Input (I ² C BUS)		
41	40	BBFi2	Bass Boost Filter 2		V ⁺ /2
42	41	BBFi1	Bass Boost Filter 1		

■TERMINAL DESCRIPTION

No.		SYMBOL	FUNCTION	EQUIVALENT CIRCUIT	VOLTAGE
SSOP	QFP				
44	43	Vref	Reference Voltage		$V^+/2$

APPLICATION CIRCUIT 1 (SSOP44)

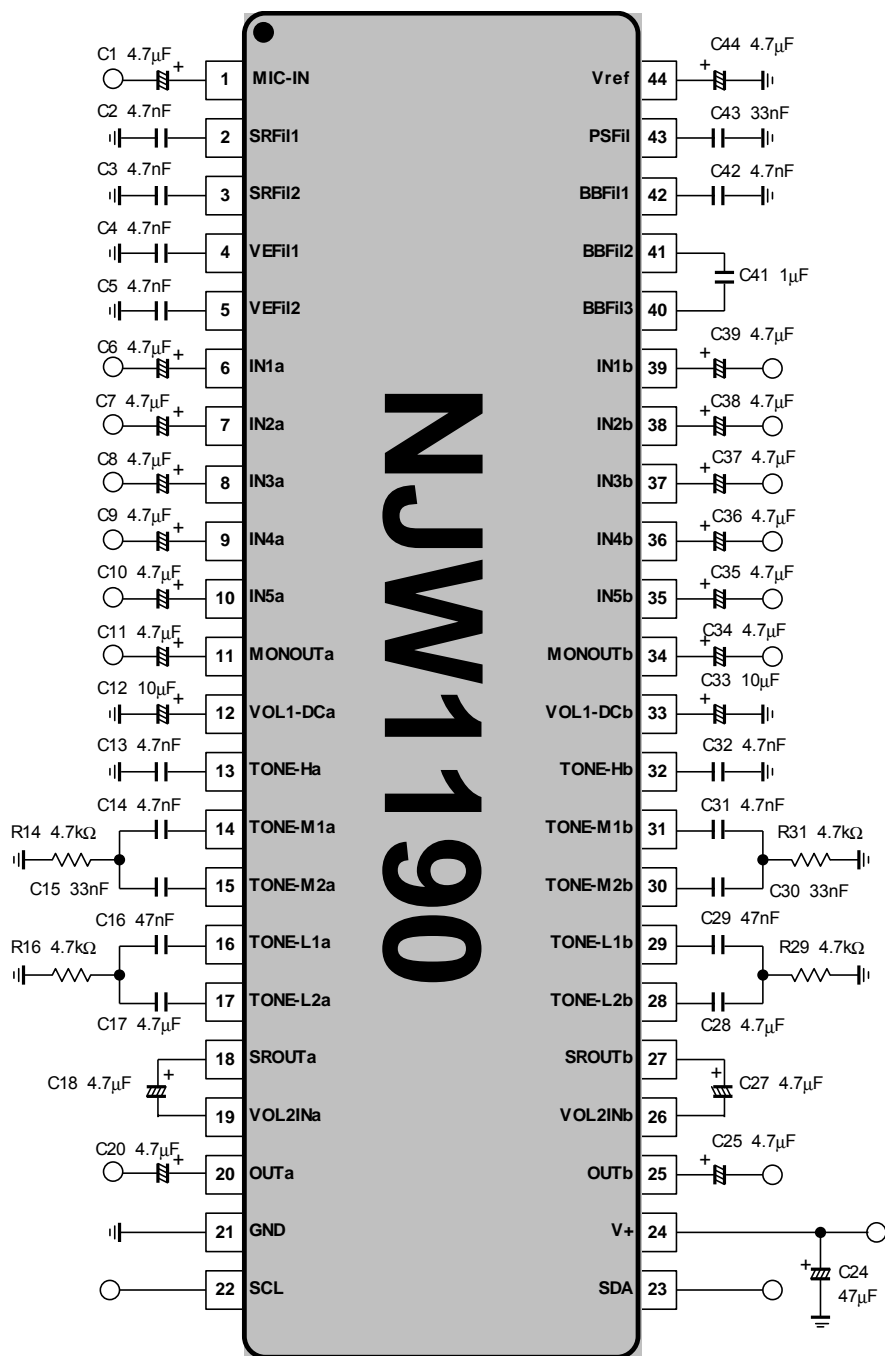

(*) Separate the I²C bus line and Signal line from the following terminals for avoiding digital noise problem and cross talk.

Pin No.	Function
1, 6 - 10, 35 - 39	Input terminals
2 - 5, 43	Surround, Voice Enhancement Filter terminals
13 - 17, 28 - 32	Tone Control Filter terminals
40 - 42	Bass Boost Filter terminals

(*) The input terminals (1, 6 - 10, 35 - 39 pin) impedance is designed about 32k ohms. The ground line should be inserted between each input lines to avoid cross talk.

APPLICATION CIRCUIT 2 (QFP48-P1)

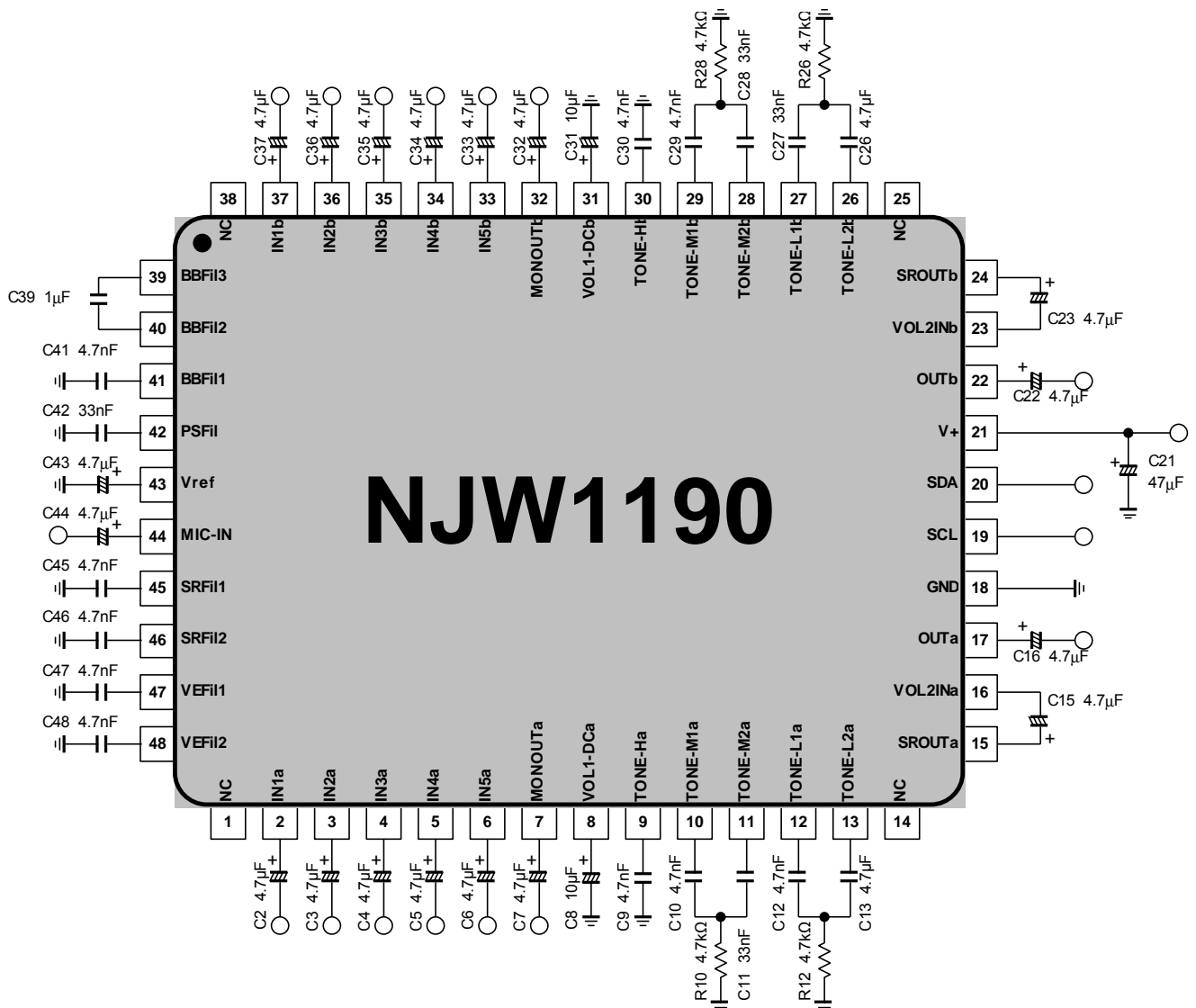

(*) Separate the I²C bus line and Signal line from the following terminals for avoiding digital noise problem and cross talk.

Pin No.	Function
44, 2 - 6, 33 - 37	Input terminals
45 - 48, 42	Surround, Voice Enhancement Filter terminals
9 - 13, 26 - 30	Tone Control Filter terminals
39 - 41	Bass Boost Filter terminals

(*) The input terminals (44, 2 - 6, 33 - 37 pin) impedance is designed about 32k ohms.
The ground line should be inserted between each input lines to avoid cross talk.

APPLICATION NOTE

(1) TONE Control Application note

(a) Bass Control

(a-1) Boost

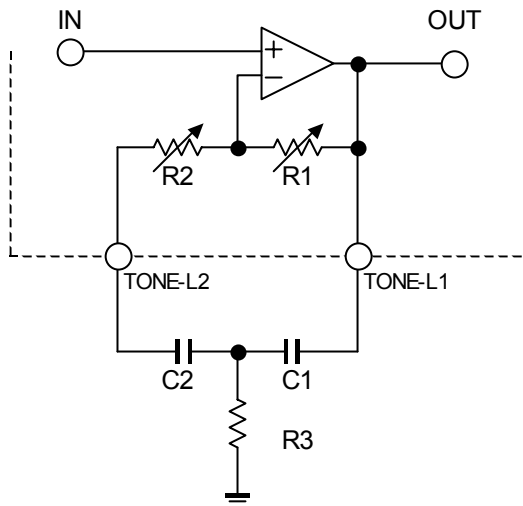

(a-2) Cut

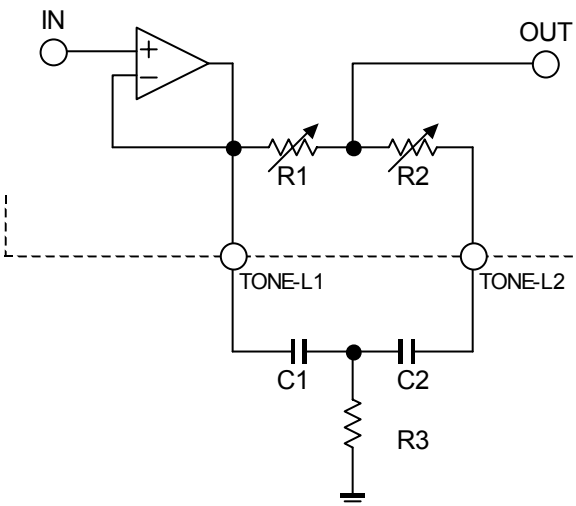

$$f_0 = \frac{1}{2\pi\sqrt{(R1 + R2) \times R3 \times C1 \times C2}}$$

$$Q = \frac{\sqrt{(R1 + R2) \times R3 \times C1 \times C2}}{R2 \times C2 + R3 \times (C1 + C2)}$$

$$G_0 = \pm 20 \text{Log} \frac{(R1 + R2 + R3) \times C2 + R3 \times C1}{R2 \times C2 + R3 \times (C1 + C2)}$$

$$C2 = \frac{G_v - 1}{2\pi \times f_0 \times Q \times R1}$$

$$C1 = \frac{R1^2 \times C2 \times Q^2}{(R1 + R2) \times \{G_v \times (R1 + 2 \times R2) - G_v^2 \times R2 - (R1 + R2)\} - R1^2 \times Q^2}$$

$$R3 = \frac{(R1 + R2) \times \{G_v \times (R1 + 2 \times R2) - G_v^2 \times R2 - (R1 + R2)\} - R1^2 \times Q^2}{(G_v - 1)^2 \times (R1 + R2)}$$

Table.1-a-1 : Gain vs. Internal resistance

Gain	R1	R2
±14dB	34kΩ	2kΩ
±10dB	28.6kΩ	7.4kΩ
±6dB	20.8kΩ	15.2kΩ
±2dB	8.4kΩ	27.6kΩ

Table.1-a-2 (fc : variable)
Gain=14dB, fc =variable
C1 =changed, C2=4.7uF, R3=4.7kΩ

fc	C1
29Hz	220nF
63 Hz	100nF
130 Hz	47nF
285 Hz	22nF

Gain vs Frequency (ToneBass:14dB)

V+=9V, Vin=0.1Vrms, Rg=0Ω, Ta=25°C
C1=changed, C2=4.7uF, R3=4.7kΩ

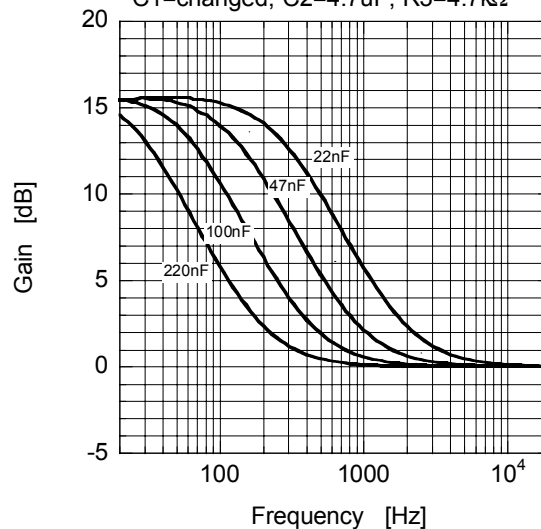
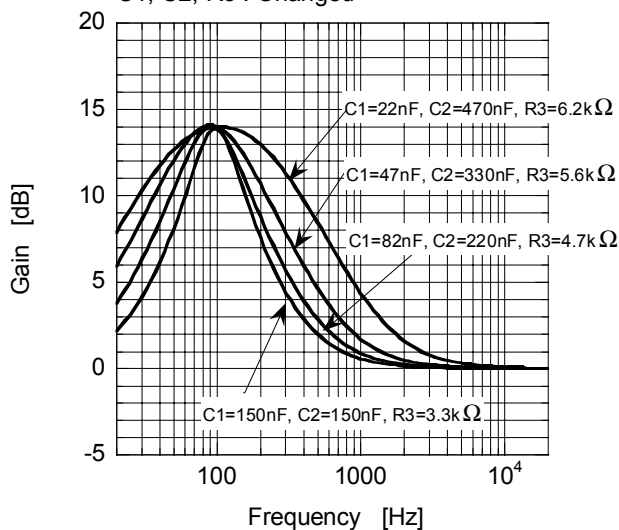

Table.1-a-3 (Q : variable)
f₀≈100Hz, Gain=14dB, Q =variable
C1, C2, R3=changed

Q	C1	C2	R3
0.4	22nF	470nF	6.2kΩ
0.6	47nF	330nF	5.6kΩ
0.9	82nF	220nF	4.7kΩ
1.3	150nF	150nF	3.3kΩ

Gain vs Frequency (ToneBass:14dB)

V+=9V, Vin=0.1Vrms, Rg=0Ω, Ta=25°C
C1, C2, R3 : Changed



(b) Middle Control

(b-1) Boost

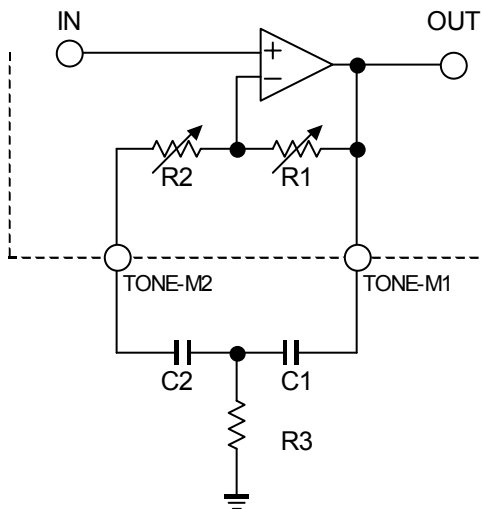

(b-2) Cut

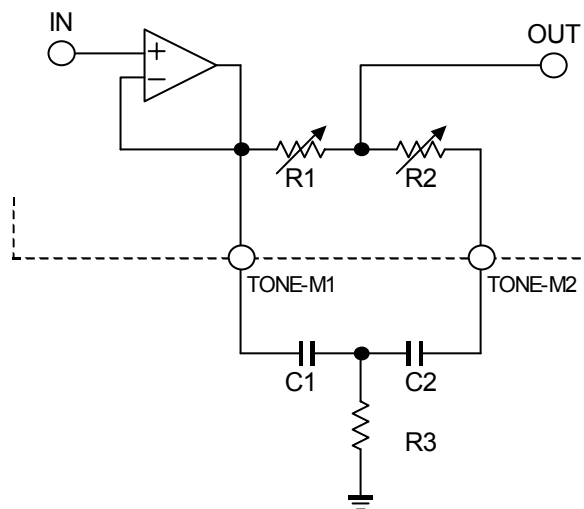

$$f_0 = \frac{1}{2\pi\sqrt{(R1+R2)\times R3\times C1\times C2}}$$

$$Q = \frac{\sqrt{(R1+R2)\times R3\times C1\times C2}}{R2\times C2 + R3\times (C1+C2)}$$

$$G_0 = \pm 20 \text{Log} \frac{(R1+R2+R3)\times C2 + R3\times C1}{R2\times C2 + R3\times (C1+C2)}$$

$$C2 = \frac{G_v - 1}{2\pi \times f_0 \times Q \times R1}$$

$$C1 = \frac{R1^2 \times C2 \times Q^2}{(R1+R2) \times \{G_v \times (R1+2 \times R2) - G_v^2 \times R2 - (R1+R2)\} - R1^2 \times Q^2}$$

$$R3 = \frac{(R1+R2) \times \{G_v \times (R1+2 \times R2) - G_v^2 \times R2 - (R1+R2)\} - R1^2 \times Q^2}{(G_v - 1)^2 \times (R1+R2)}$$

Table.1-b-1 : Gain vs. Internal resistance

Gain	R1	R2
±14dB	31.5kΩ	2.5kΩ
±6dB	27kΩ	7kΩ
±6dB	19.6kΩ	14.4kΩ
±2dB	8.2kΩ	25.8kΩ

Table.1-b-2 (Q : variable)
 $f_0 \approx 1\text{kHz}$, Gain=14dB, Q =variable
 C1, C2, R3=changed

Q	C1	C2	R3
0.44	3.3nF	47nF	5k Ω
0.6	4.7nF	33nF	4.7k Ω
1.0	10nF	22nF	3.6k Ω
1.3	22nF	15nF	2.2k Ω

Gain vs Frequency (ToneMiddle:14dB)

$V_+ = 9\text{V}$, $V_{in} = 0.1\text{Vrms}$, $R_g = 0\Omega$, $T_a = 25^\circ\text{C}$
 C1, C2, R3 : Changed

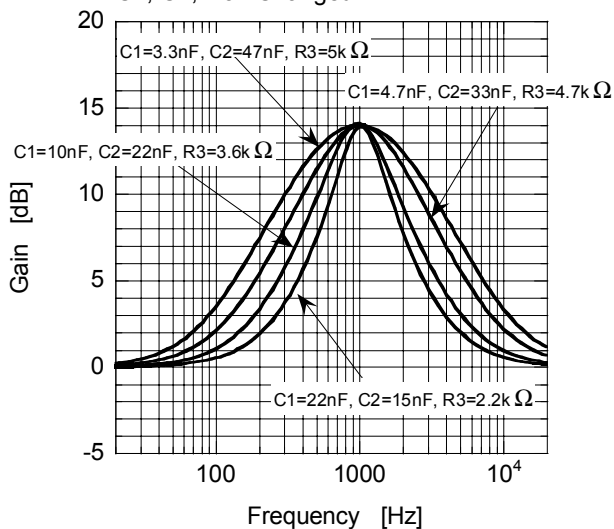
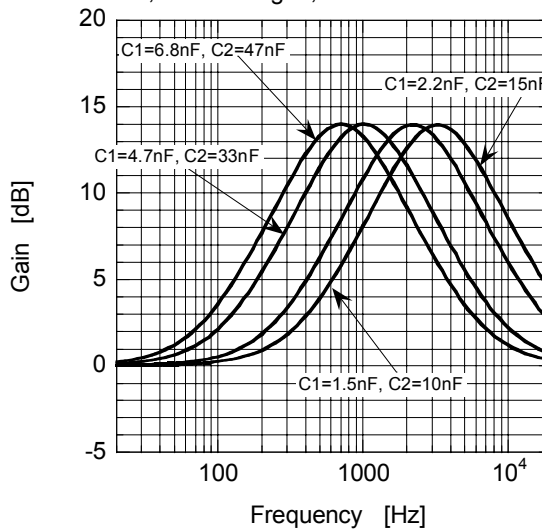

Table.1-b-3 (f_0 : variable)
 $Q \approx 0.6$, Gain=14dB, f_0 =variable
 C1, C2 =changed, R3=4.7k Ω

f_0	C1	C2	R3
700Hz	6.8nF	47nF	4.7k Ω
1kHz	4.7nF	33nF	4.7k Ω
2.2kHz	2.2nF	15nF	4.7k Ω
3.2kHz	1.5nF	10nF	4.7k Ω

Gain vs Frequency (ToneMiddle:14dB)

$V_+ = 9\text{V}$, $V_{in} = 0.1\text{Vrms}$, $R_g = 0\Omega$, $T_a = 25^\circ\text{C}$
 C1, C2 =Changed, R3=4.7k Ω



(c) Treble Control

(c-1) Boost

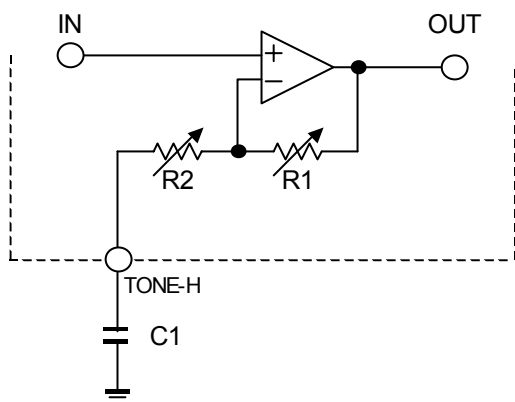

(c-2) Cut

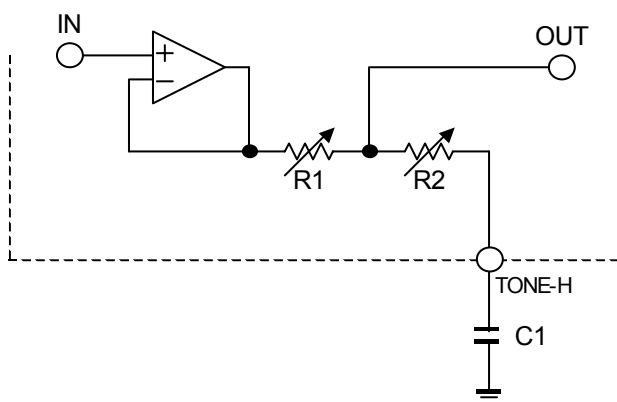

$$G_v = \pm 20 \text{Log} \left[1 + \frac{R1}{R2} \times \frac{1}{\sqrt{1 + (1/\omega \times C1 \times R2)^2}} \right]$$

Table.1-c-1 : Gain vs. Internal resistance

Gain	R1	R2
±14dB	22kΩ	4kΩ
±6dB	18.4kΩ	7.6kΩ
±6dB	13.3kΩ	12.7kΩ
±2dB	5.5kΩ	20.5kΩ

Table.1-c-2 (fc : variable)
Gain=14dB, fc =variable
C1 =changed

fc	C1
1.8kHz	22nF
4kHz	10nF
8.5kHz	4.7nF
18kHz	2.2nF

Gain vs Frequency (ToneTreble:14dB)

V+=9V, Vin=0.1Vrms, Rg=0Ω, Ta=25°C
C1 = Changed

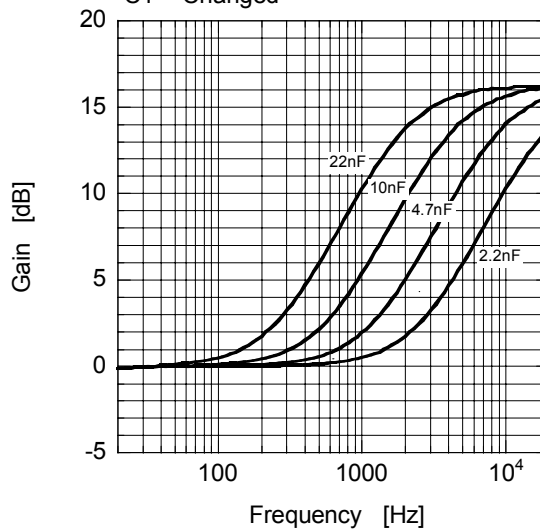

(2) Surround Application note

(a) eala

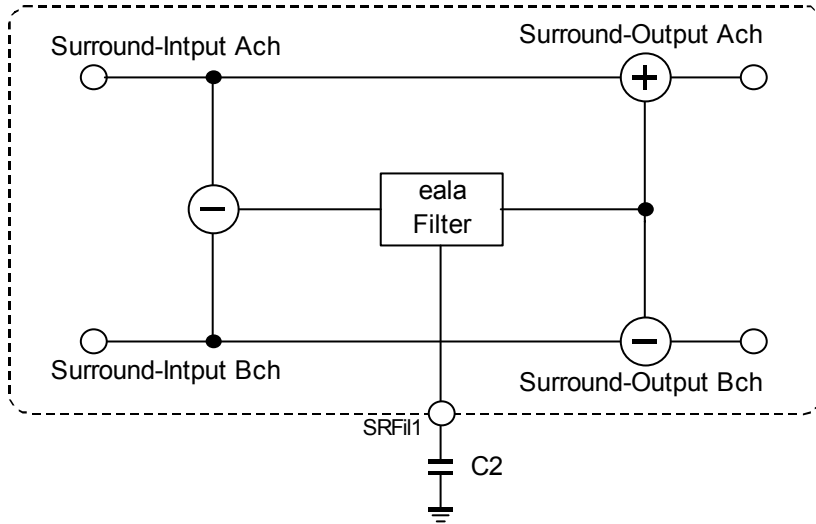

The eala effect depends on the external capacitor C2.
It becomes larger as the capacity smaller. (refer to the following figure)

Gain vs Frequency (eala)

V+=9V, Vin=0.1Vrms, Rg=0Ω, Ta=25°C
SRFil1(C2)=changed

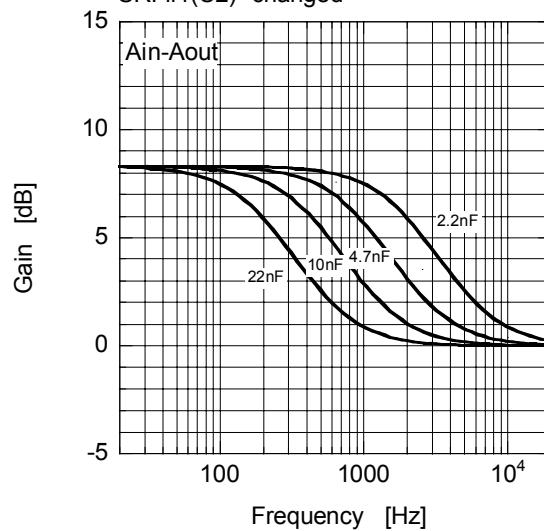

(b) Surround

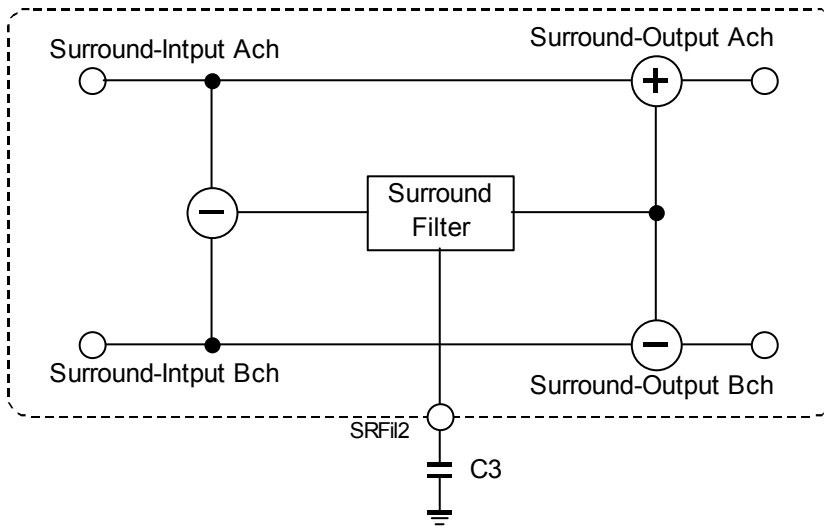

The surround effect depends on the external capacitor C3.
It becomes larger as the capacity smaller. (refer to the following figure)

Gain vs Frequency (Surround)

$V+=9V$, $V_{in}=0.1V_{rms}$, $R_g=0\Omega$, $T_a=25^\circ C$
SRFil2(C3) = changed

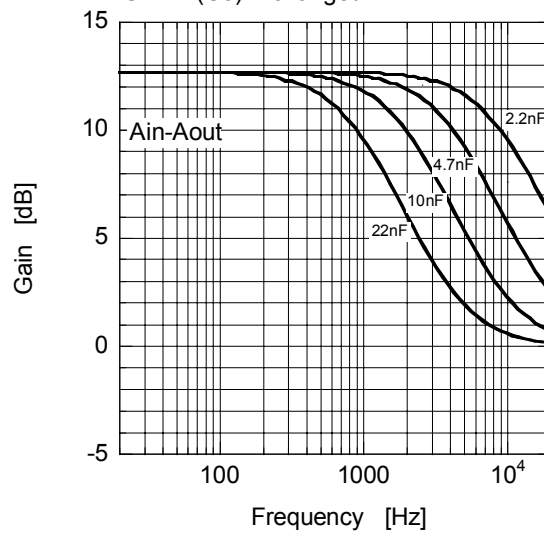

(c) Surround + PS (PS: Phase Shift)

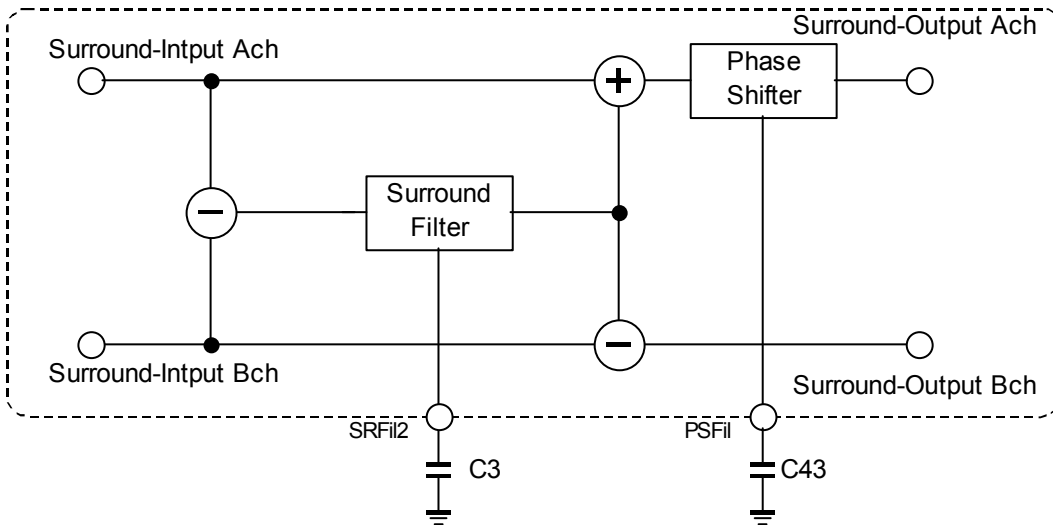

The PS effect depends on the external capacitor C43.
It becomes larger as the capacity larger. (refer to the following figure)

Phase vs Frequency (PS)

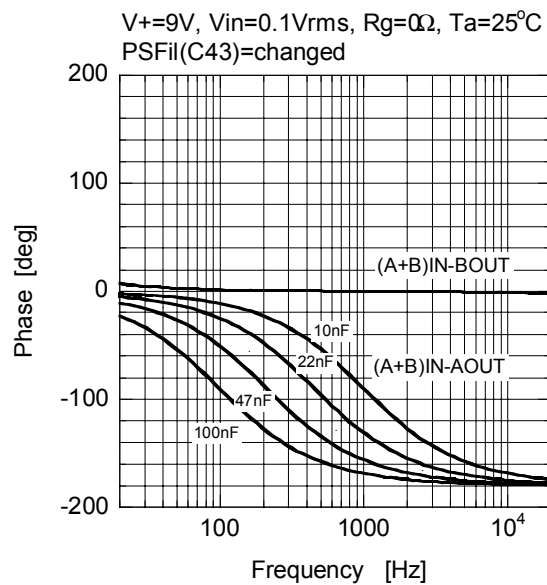

(d) Voice Enhancement (VE)

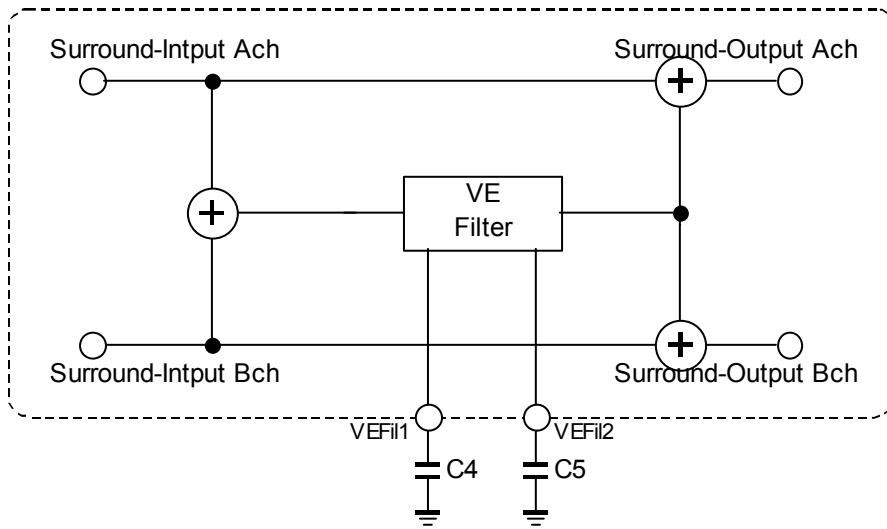

The Voice Enhancement (VE) mode amplifies the same phase signal such as vocal signal. The VE (Voice Enhancement) effect depends on the external capacitor C4, C5. (refer to the following figure)

Gain vs Frequency (VE)

$V_+ = 9V$, $V_{in} = 0.1V_{rms}$, $R_g = \Omega$, $T_a = 25^\circ C$
 $VEFil1(C4)$, $VEFil2(C5)$ = changed

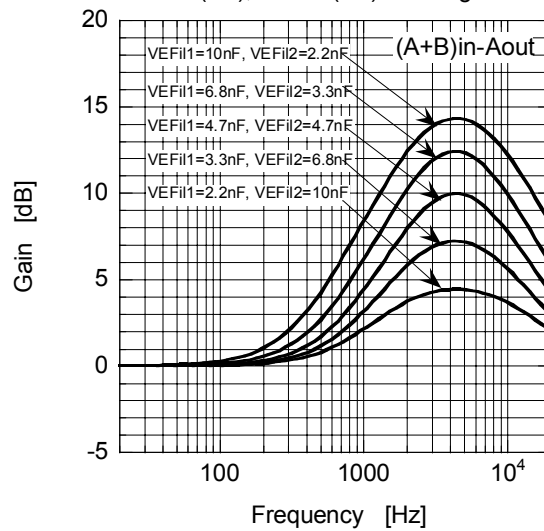

(3) BassBoost Application note

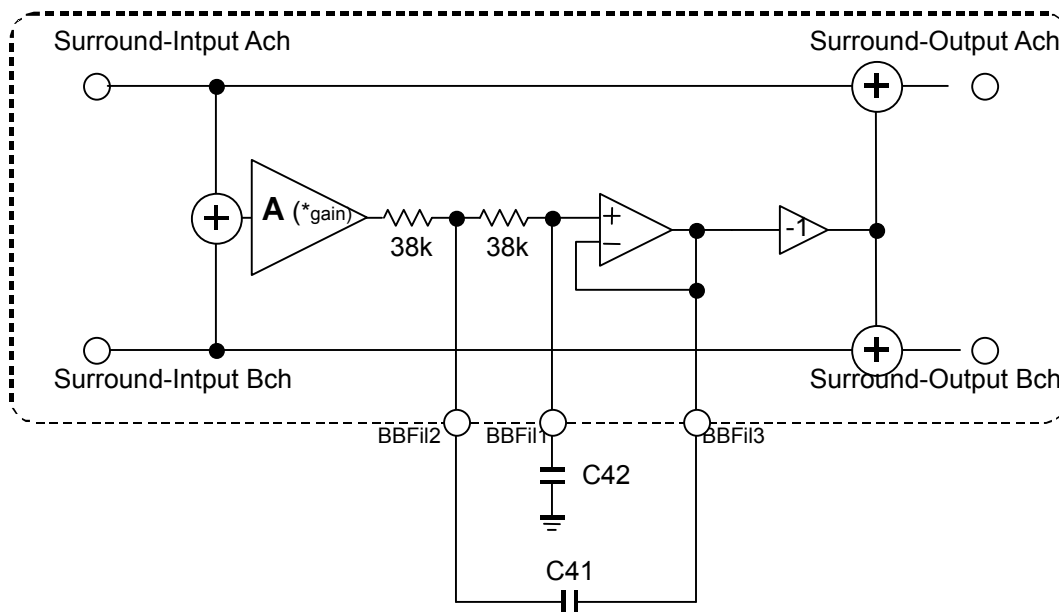

The BassBoost frequency characteristics depend on external capacitor C41 ,C42.
The value of A (*gain) is selectable via I²C bus. (Refer to Table.3-1)

Table.3-1 : Bass Boost Gain vs. A (*gain)

Bass Boost Gain Setting	05H D4	05H D3	A (*gain)
18dB	0	1	1 (0dB)
24dB	1	0	2 (6dB)
29dB	1	1	4 (12dB)

$$f_0 = \frac{1}{2 \times \pi \times R \times \sqrt{C41 \times C42}}$$

$$Q = \frac{1}{2} \times \sqrt{\frac{C41}{C42}}$$

$$G_0(dB) = 20 \times LOG \sqrt{1 + A^2 \times Q^2} = 20 \times LOG \sqrt{1 + \frac{A^2 \times C41}{4 \times C42}}$$

* Input signal : Ach + Bch (same phase)

Table.3-2-(a)
 $f_0 \approx 60\text{Hz}$, $A=1$, Q & G_0 =variable

Q	G_0	C41	C42
0.7	1.9dB	100nF	47nF
1.6	5.4dB	220nF	15nF
3.5	11.6dB	470nF	10nF
7.3	17.3dB	1 μ F	4.7nF

Gain vs Frequency (BassBoost)

$V+=9\text{V}$, $V(A+B)_{in}=0.05\text{Vrms}$, $R_g=0\Omega$, $T_a=25^\circ\text{C}$
 Boost Gain 1, C41,C42 = changed

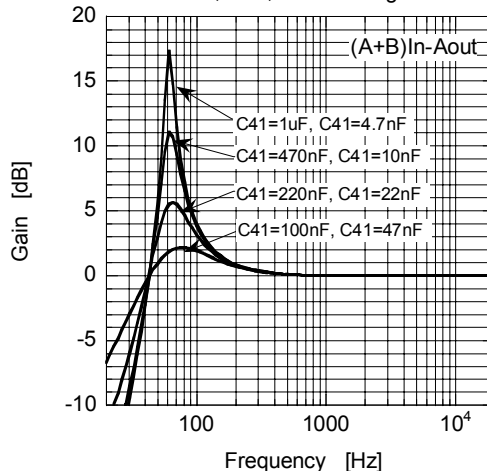

Table.3-2-(b) (C41, C42 : Sweep)
 $Q \approx 7.3$, $G_0 \approx 17.3\text{dB}$, $A=1$, f_0 =variable

f_0	C41	C42
60Hz	1 μ F	4.7nF
89Hz	680nF	3.3nF
130Hz	470nF	2.2nF
282Hz	220nF	1 μ F

Gain vs Frequency (BassBoost)

$V+=9\text{V}$, $V(A+B)_{in}=0.05\text{Vrms}$, $R_g=0\Omega$, $T_a=25^\circ\text{C}$
 Boost Gain 1, C41,C42 = changed

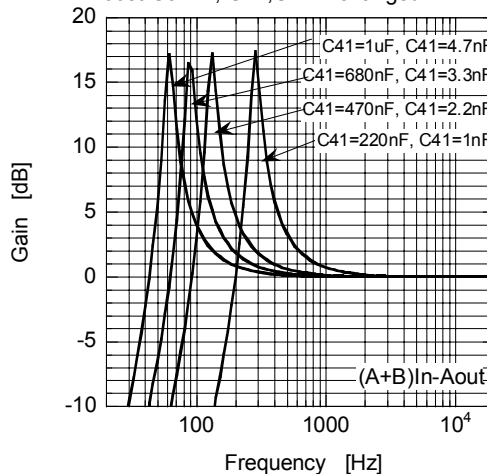
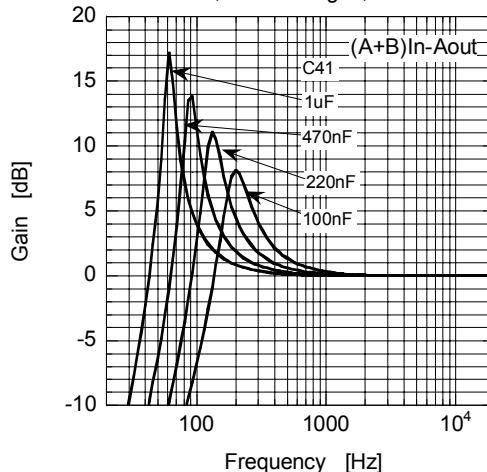

Table.3-2-(c) (C41 : Sweep)
 $f_0 \approx 60\text{Hz}$, $A=1$, C41=variable

f_0	Q	G_0	C41
60Hz	7.3	17.3dB	1 μ F
89Hz	5	14.1dB	470nF
130Hz	3.4	11.0dB	220nF
193Hz	2.3	8.0dB	100nF

Gain vs Frequency (BassBoost)

$V+=9\text{V}$, $V(A+B)_{in}=0.05\text{Vrms}$, $R_g=0\Omega$, $T_a=25^\circ\text{C}$
 Boost Gain 1, C41=changed, C42=4.7nF



■ DEFINITION OF I²C REGISTER

◆ I²C BUS FORMAT



S: Starting Term
A: Acknowledge Bit
P: Ending Term

◆ SLAVE ADDRESS

Slave Address								Hex
MSB				LSB				-
1	0	0	0	1	0	0	0	88(h)

◆ CONTROL REGISTER TABLE

The select address sets each function (Volume, Microphone Input Gain, Tone Control, Input Gain, Surround, Bass Boost, Input Selector).

The auto increment function cycles the select address as follows.

00H → 01H → 02H → 03H → 04H → 05H → 00H

<Write Mode>

Select Address	BIT							
	D7	D6	D5	D4	D3	D2	D1	D0
00H	VOL1						*	
01H	VOL2A						*	
02H	VOL2B						MICGV	
03H	BCB	BASS			GVIN			MICSW
04H	BCM	MID			BCT	TREB		
05H	SUR			BB		SEL		

* : Don't Care

◆ CONTROL REGISTER DEFAULT VALUE

Control register default value is all "0".

Select Address	BIT							
	D7	D6	D5	D4	D3	D2	D1	D0
00H	0	0	0	0	0	0	0	0
01H	0	0	0	0	0	0	0	0
02H	0	0	0	0	0	0	0	0
03H	0	0	0	0	0	0	0	0
04H	0	0	0	0	0	0	0	0
05H	0	0	0	0	0	0	0	0

■ INSTRUCTION CODE

a) MASTER VOLUME1 SETTING

Select Address	BIT							
	D7	D6	D5	D4	D3	D2	D1	D0
00H	VOL1						*	

* : Don't Care

•Volume1 Level : 0 to -44dB (1dB/Step) , MUTE

b) MASTER VOLUME2A SETTING

Select Address	BIT							
	D7	D6	D5	D4	D3	D2	D1	D0
01H	VOL2A						*	

* : Don't Care

•Volume2A Level : 0 to -44dB (1dB/Step) , MUTE

c) MASTER VOLUME2B, Microphone Gain SETTING

Select Address	BIT							
	D7	D6	D5	D4	D3	D2	D1	D0
02H	VOL2B						MICGV	

•Volume2B Level : 0 to -44dB (1dB/Step) , MUTE

<MICGV : Microphone Input Gain Setting>

Mic Input Gain Setting	D1	D0
0dB	0	0
6dB	0	1
10dB	1	0
14dB	1	1

d) TONE CONTROL BASS, Microphone SW SETTING

Select Address	BIT							
	D7	D6	D5	D4	D3	D2	D1	D0
03H	BCB	BASS			GVIN			MICSW

* : Don't Care

- BCB : Boost cut select for Bass control
 "0" : Cut
 "1" : Boost
- BASS : BASS Level Setting
 Cut Level : -14 to 0dB(2dB/Step)
 Boost Level : 0 to +14dB(2dB/Step)

<GVIN : Input Gain Setting>

Input Gain Setting	D3	D2	D1
0dB	0	0	0
2dB	0	0	1
4dB	0	1	0
6dB	0	1	1
8dB	1	0	0
10dB	1	0	1
12dB	1	1	0
14dB	1	1	1

<MICSW : Microphone SW Setting>

Microphone SW Setting	D0
MUTE	0
ON	1

d) TONE CONTROL MIDDLE, TREBLE SETTING

Select Address	BIT							
	D7	D6	D5	D4	D3	D2	D1	D0
04H	BCM	MID			BCT	TREB		

- BCM : Boost cut select for Middle control
 "0" : Cut
 "1" : Boost
- MID : Middle Level Setting
 Cut Level : -14 to 0dB(2dB/Step)
 Boost Level : 0 to +14dB(2dB/Step)
- BCT : Boost cut select for Treble control
 "0" : Cut
 "1" : Boost
- TREB : Treble Level Setting
 Cut Level : -14 to 0dB(2dB/Step)
 Boost Level : 0 to +14dB(2dB/Step)

e) Surround, Bass Boost, Input Selector SETTING

Select Address	BIT							
	D7	D6	D5	D4	D3	D2	D1	D0
05H	SUR			BB			SEL	

<SUR : Surround Level Setting>

Surround Setting	D7	D6	D5	Remarks
Bypass	0	0	0	Bypass
SUR1	0	0	1	eala
SUR2	0	1	0	eala+VE *1
SUR3	0	1	1	Surround+VE
SUR4	1	0	0	Surround
SUR5	1	0	1	Surround+PS *2

VE *1 : Voice Enhancement
PS *2 : Phase Shifter

<BB : Bass Boost Gain Setting>

Bass Boost Gain Setting	D4	D3
OFF	0	0
18dB	0	1
24dB	1	0
29dB	1	1

<SEL : Input Selector Setting >

Input Selector Setting	D2	D1	D0
INPUT1	0	0	0
INPUT2	0	0	1
INPUT3	0	1	0
INPUT4	0	1	1
INPUT5	1	0	0

■MASTER VOLUME1 (Select Address : 00H)

Gain(dB)	VOL1					
	D7	D6	D5	D4	D3	D2
0	1	1	1	1	1	1
-1	1	1	1	1	1	0
-2	1	1	1	1	0	1
-3	1	1	1	1	0	0
-4	1	1	1	0	1	1
-5	1	1	1	0	1	0
-6	1	1	1	0	0	1
-7	1	1	1	0	0	0
-8	1	1	0	1	1	1
-9	1	1	0	1	1	0
-10	1	1	0	1	0	1
-11	1	1	0	1	0	0
-12	1	1	0	0	1	1
-13	1	1	0	0	1	0
-14	1	1	0	0	0	1
-15	1	1	0	0	0	0
-16	1	0	1	1	1	1
-17	1	0	1	1	1	0
-18	1	0	1	1	0	1
-19	1	0	1	1	0	0
-20	1	0	1	0	1	1
-21	1	0	1	0	1	0
-22	1	0	1	0	0	1
-23	1	0	1	0	0	0
-24	1	0	0	1	1	1
-25	1	0	0	1	1	0
-26	1	0	0	1	0	1
-27	1	0	0	1	0	0
-28	1	0	0	0	1	1
-29	1	0	0	0	1	0
-30	1	0	0	0	0	1
-31	1	0	0	0	0	0
-32	0	1	1	1	1	1
-33	0	1	1	1	1	0
-34	0	1	1	1	0	1
-35	0	1	1	1	0	0
-36	0	1	1	0	1	1
-37	0	1	1	0	1	0
-38	0	1	1	0	0	1
-39	0	1	1	0	0	0
-40	0	1	0	1	1	1
-41	0	1	0	1	1	0
-42	0	1	0	1	0	1
-43	0	1	0	1	0	0
-44	0	1	0	0	1	1
Mute	0	0	0	0	0	0

■MASTER VOLUME2A (Select Address : 01H)

Gain(dB)	VOL2A					
	D7	D6	D5	D4	D3	D2
0	1	1	1	1	1	1
-1	1	1	1	1	1	0
-2	1	1	1	1	0	1
-3	1	1	1	1	0	0
-4	1	1	1	0	1	1
-5	1	1	1	0	1	0
-6	1	1	1	0	0	1
-7	1	1	1	0	0	0
-8	1	1	0	1	1	1
-9	1	1	0	1	1	0
-10	1	1	0	1	0	1
-11	1	1	0	1	0	0
-12	1	1	0	0	1	1
-13	1	1	0	0	1	0
-14	1	1	0	0	0	1
-15	1	1	0	0	0	0
-16	1	0	1	1	1	1
-17	1	0	1	1	1	0
-18	1	0	1	1	0	1
-19	1	0	1	1	0	0
-20	1	0	1	0	1	1
-21	1	0	1	0	1	0
-22	1	0	1	0	0	1
-23	1	0	1	0	0	0
-24	1	0	0	1	1	1
-25	1	0	0	1	1	0
-26	1	0	0	1	0	1
-27	1	0	0	1	0	0
-28	1	0	0	0	1	1
-29	1	0	0	0	1	0
-30	1	0	0	0	0	1
-31	1	0	0	0	0	0
-32	0	1	1	1	1	1
-33	0	1	1	1	1	0
-34	0	1	1	1	0	1
-35	0	1	1	1	0	0
-36	0	1	1	0	1	1
-37	0	1	1	0	1	0
-38	0	1	1	0	0	1
-39	0	1	1	0	0	0
-40	0	1	0	1	1	1
-41	0	1	0	1	1	0
-42	0	1	0	1	0	1
-43	0	1	0	1	0	0
-44	0	1	0	0	1	1
Mute	0	0	0	0	0	0

■MASTER VOLUME2B (Select Address : 02H)

Gain(dB)	VOL2B					
	D7	D6	D5	D4	D3	D2
0	1	1	1	1	1	1
-1	1	1	1	1	1	0
-2	1	1	1	1	0	1
-3	1	1	1	1	0	0
-4	1	1	1	0	1	1
-5	1	1	1	0	1	0
-6	1	1	1	0	0	1
-7	1	1	1	0	0	0
-8	1	1	0	1	1	1
-9	1	1	0	1	1	0
-10	1	1	0	1	0	1
-11	1	1	0	1	0	0
-12	1	1	0	0	1	1
-13	1	1	0	0	1	0
-14	1	1	0	0	0	1
-15	1	1	0	0	0	0
-16	1	0	1	1	1	1
-17	1	0	1	1	1	0
-18	1	0	1	1	0	1
-19	1	0	1	1	0	0
-20	1	0	1	0	1	1
-21	1	0	1	0	1	0
-22	1	0	1	0	0	1
-23	1	0	1	0	0	0
-24	1	0	0	1	1	1
-25	1	0	0	1	1	0
-26	1	0	0	1	0	1
-27	1	0	0	1	0	0
-28	1	0	0	0	1	1
-29	1	0	0	0	1	0
-30	1	0	0	0	0	1
-31	1	0	0	0	0	0
-32	0	1	1	1	1	1
-33	0	1	1	1	1	0
-34	0	1	1	1	0	1
-35	0	1	1	1	0	0
-36	0	1	1	0	1	1
-37	0	1	1	0	1	0
-38	0	1	1	0	0	1
-39	0	1	1	0	0	0
-40	0	1	0	1	1	1
-41	0	1	0	1	1	0
-42	0	1	0	1	0	1
-43	0	1	0	1	0	0
-44	0	1	0	0	1	1
Mute	0	0	0	0	0	0

■TONE CONTROL BASS (Select Address : 03H)

Bass Cut or Boost	BCB
	D7
Cut	0
Boost	1

		BASS		
		D6	D5	D4
Cut Gain(dB)	Boost Gain(dB)			
-14	14	1	1	1
-12	12	1	1	0
-10	10	1	0	1
-8	8	1	0	0
-6	6	0	1	1
-4	4	0	1	0
-2	2	0	0	1
0	0	0	0	0

■TONE CONTROL MIDDLE (Select Address : 04H)

Middle Cut or Boost	BCM
	D7
Cut	0
Boost	1

		MIDD		
		D6	D5	D4
Cut Gain(dB)	Boost Gain(dB)			
-14	14	1	1	1
-12	12	1	1	0
-10	10	1	0	1
-8	8	1	0	0
-6	6	0	1	1
-4	4	0	1	0
-2	2	0	0	1
0	0	0	0	0

■TONE CONTROL TREBLE (Select Address : 04H)

Treble Cut or Boost	BCT
	D3
Cut	0
Boost	1

		TREB		
		D2	D1	D0
Cut Gain(dB)	Boost Gain(dB)			
-14	14	1	1	1
-12	12	1	1	0
-10	10	1	0	1
-8	8	1	0	0
-6	6	0	1	1
-4	4	0	1	0
-2	2	0	0	1
0	0	0	0	0

■ TYPICAL CHARACTERISTICS

Supply Current vs Supply Voltage

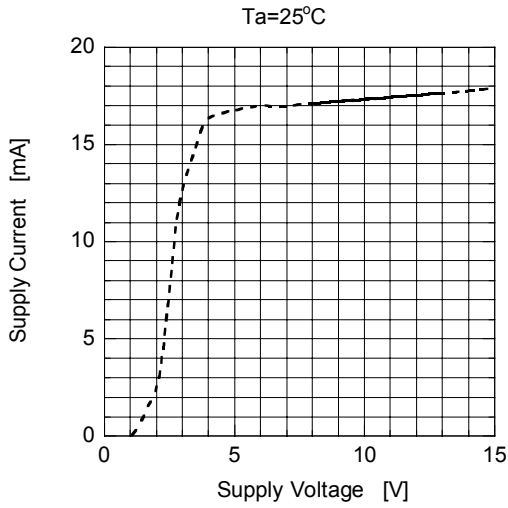

Supply Current vs Temperature

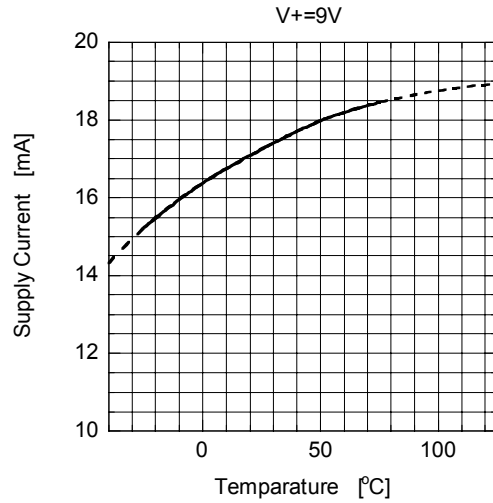

Reference Voltage vs Supply Voltage

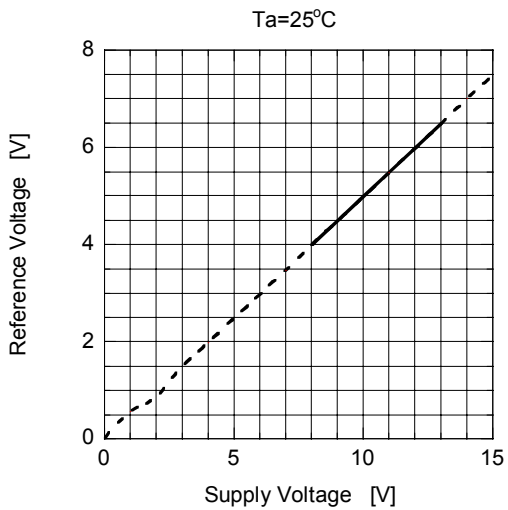

Reference Voltage vs Temperature

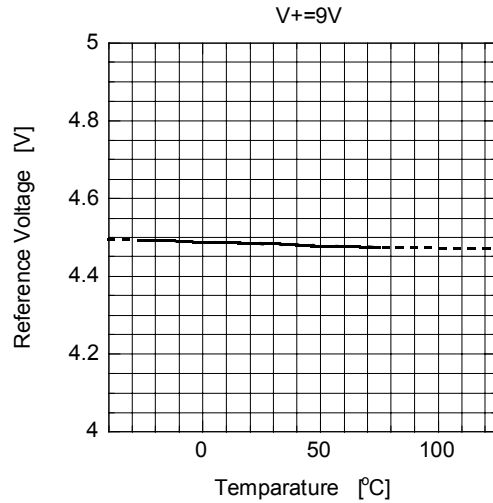

Gain vs Volume Control (1st Volume)

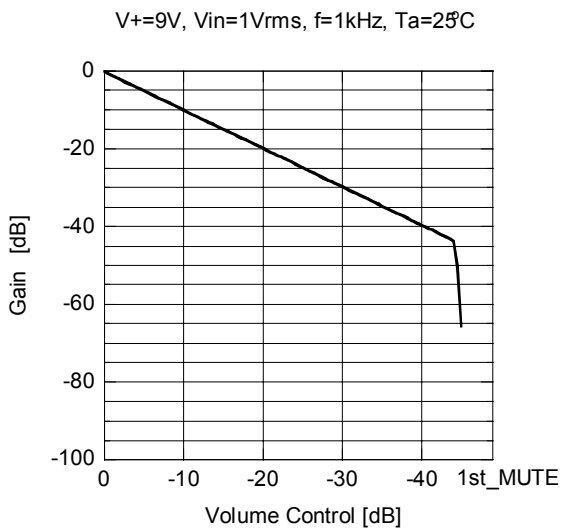

Gain vs Volume Control (2nd Volume)

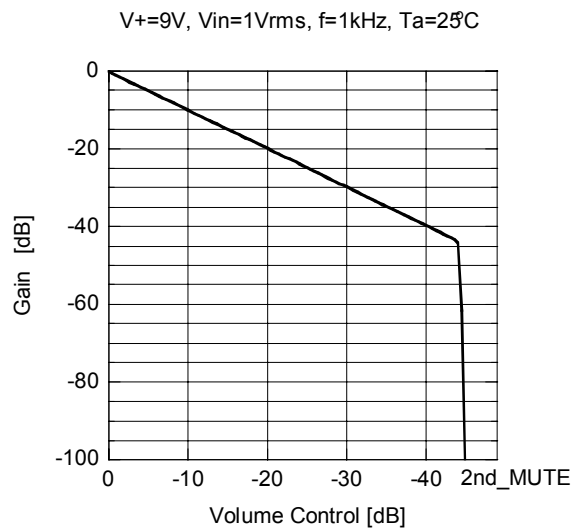

■ TYPICAL CHARACTERISTICS

Gain vs Volume Control (TOTAL)

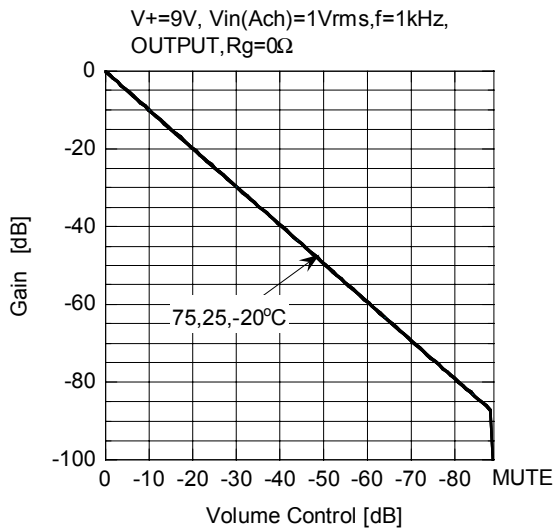

Output Noise vs Temperature

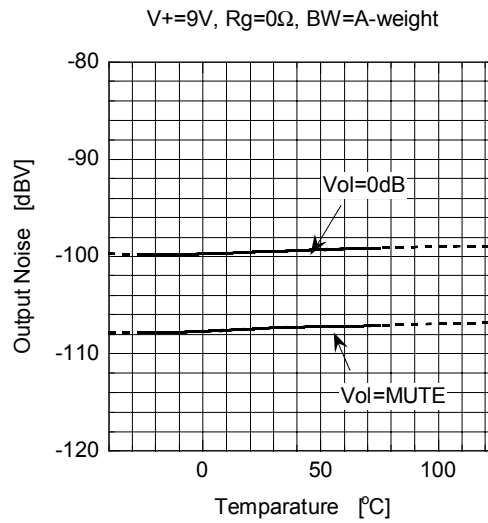

THD+N vs Input Voltage (1st VOL)

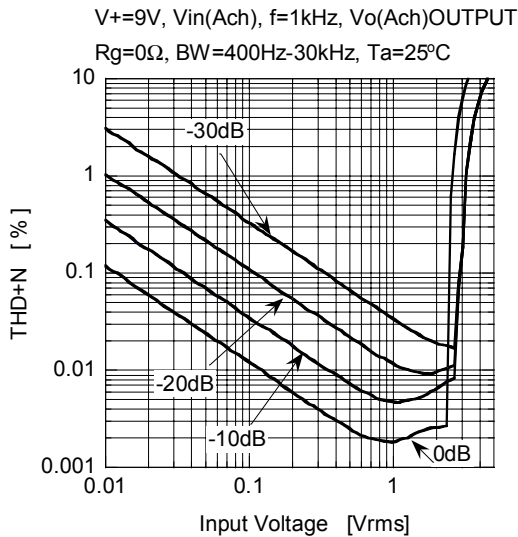

THD+N vs Input Voltage (2nd VOL)

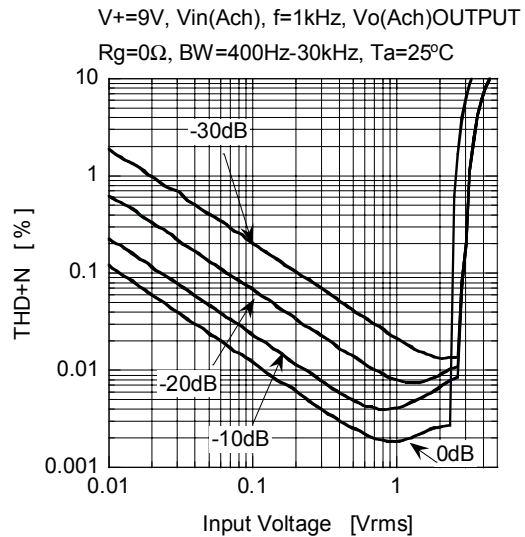

THD+N vs Output Voltage (1st VOL)

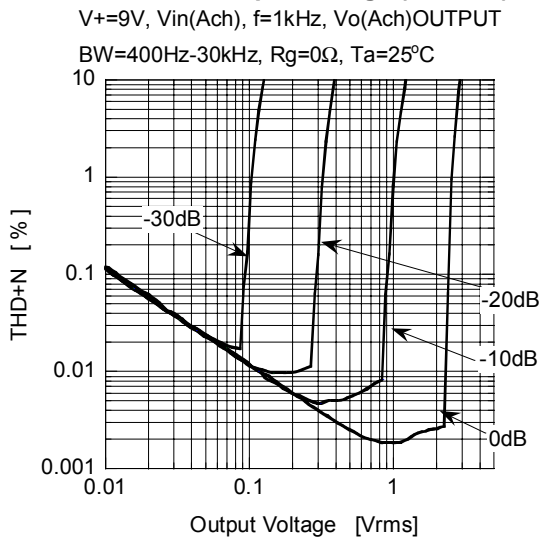

THD+N vs Output Voltage (2nd VOL)

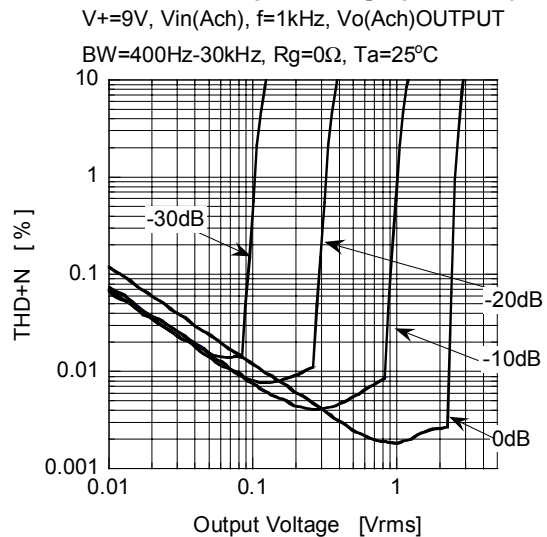

■ TYPICAL CHARACTERISTICS

THD+N vs Input Voltage

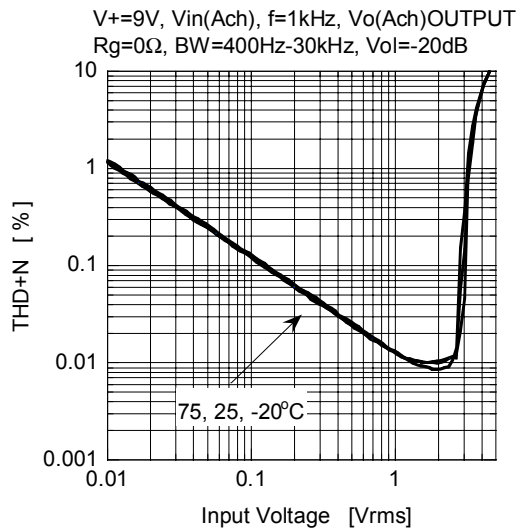

THD+N vs Output Voltage

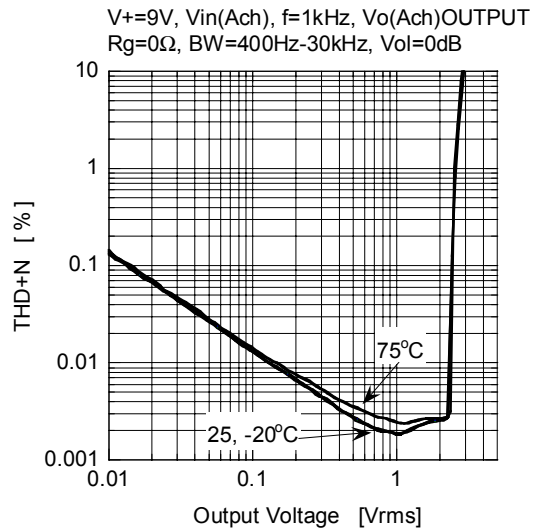

MUTE Level vs Frequency

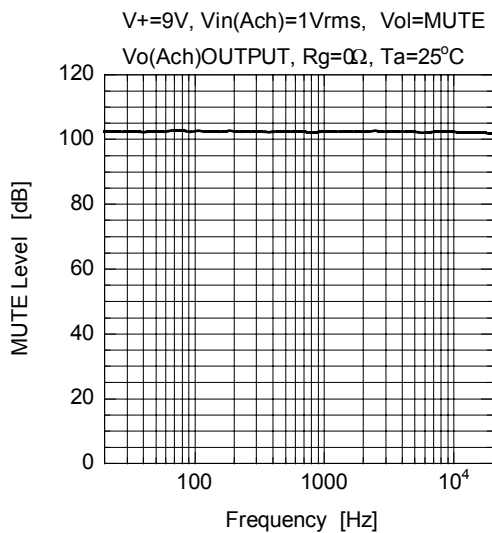

Channel Separation vs Frequency

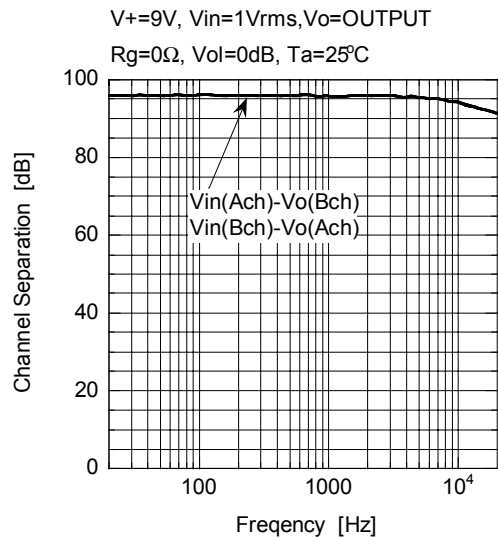

CrossTalk vs Frequency

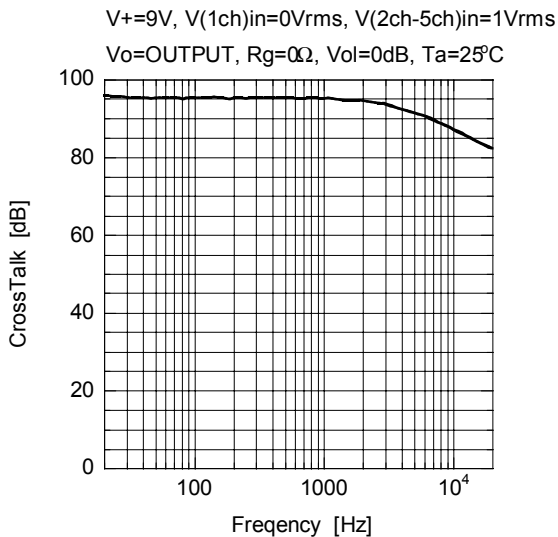

■ TYPICAL CHARACTERISTICS

Gain vs Frequency (TONE Bass)

$V+=9V$, $VOL=0dB$, $Vin=0.1Vrms$, $Ta=25^{\circ}C$

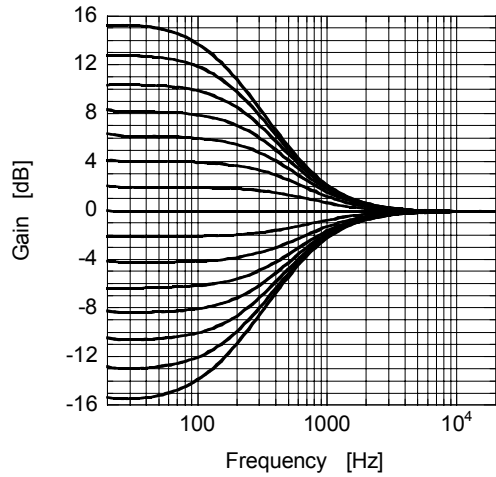

Gain vs Frequency (TONE Bass)

$V+=9V$, $Vin(Ach)=0.1Vrms$, $Gv=+14, -14dB$
 $Vo(Ach)$, $Rg=0\Omega$

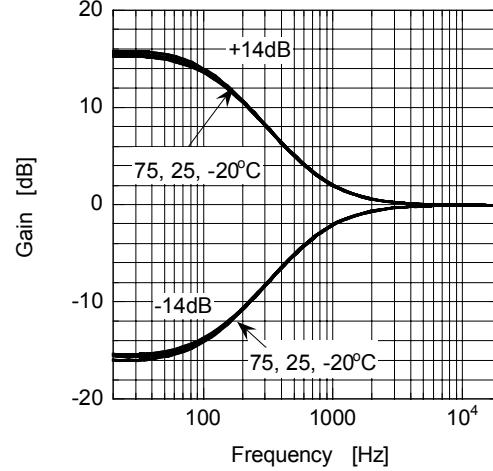

Gain vs Frequency (TONE Middle)

$V+=9V$, $VOL=0dB$, $Vin=0.1Vrms$, $Ta=25^{\circ}C$

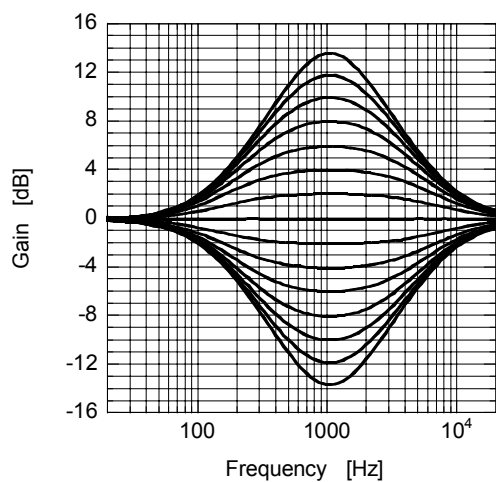

Gain vs Frequency (TONE Middle)

$V+=9V$, $Vin(Ach)=0.1Vrms$, $Gv=+14, -14dB$
 $Vo(Ach)$, $Rg=0\Omega$

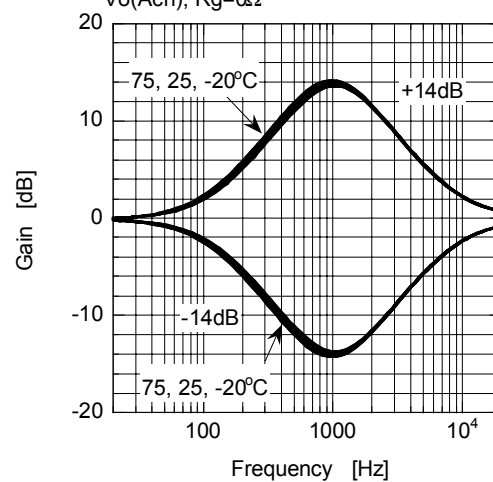

Gain vs Frequency (TONE Treble)

$V+=9V$, $VOL=0dB$, $Vin=0.1Vrms$, $Ta=25^{\circ}C$

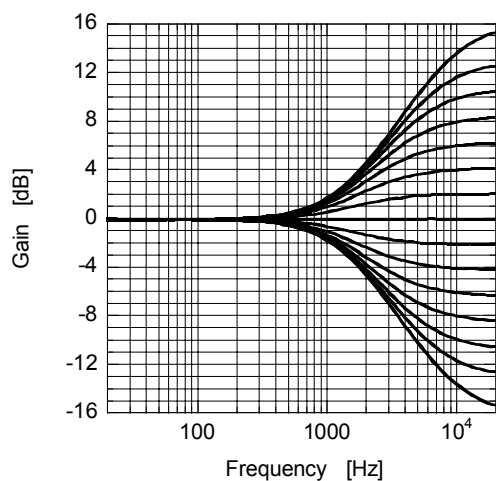

Gain vs Frequency (TONE Treble)

$V+=9V$, $Vin(Ach)=0.1Vrms$, $Gv=+14, -14dB$
 $Vo(Ach)$, $Rg=0\Omega$

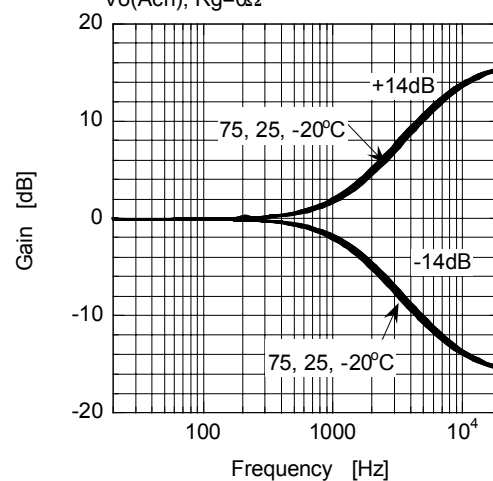

■ TYPICAL CHARACTERISTICS

Gain vs Frequency (eala)

$V+=9V, V_{in}=0.1V_{rms}, R_g=0\Omega, T_a=25^\circ C$

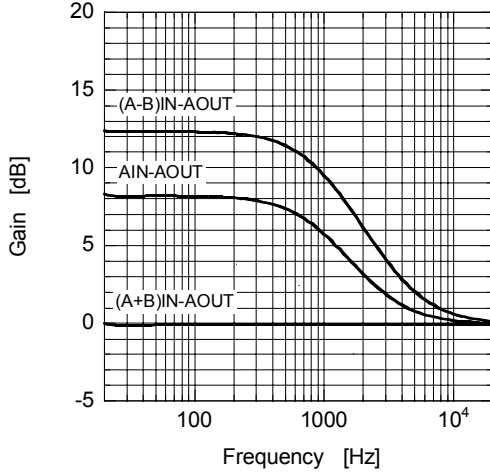

Gain vs Frequency (eala)

$V+=9V, V_{in}=0.1V_{rms}, R_g=0\Omega$

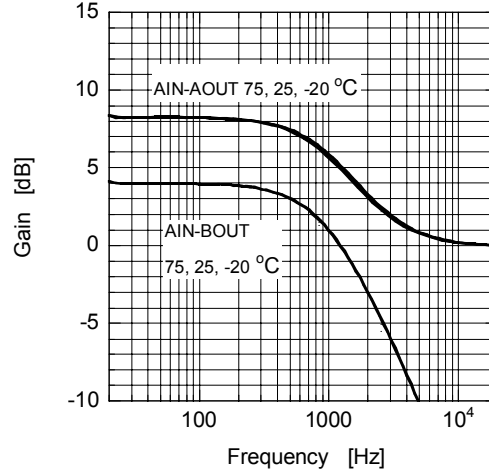

Gain vs Frequency (Surround)

$V+=9V, V_{in}=0.1V_{rms}, R_g=0\Omega, T_a=25^\circ C$

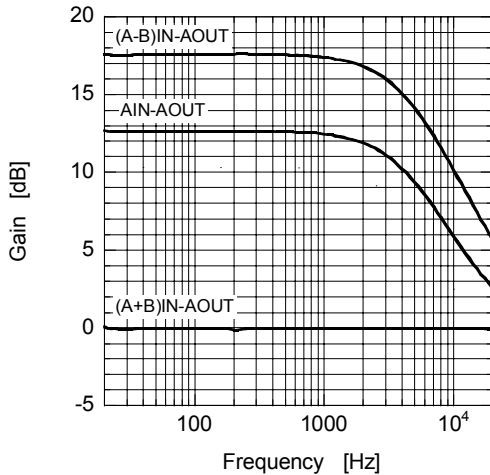

Gain vs Frequency (Surround)

$V+=9V, V_{in}=0.1V_{rms}, R_g=0\Omega$

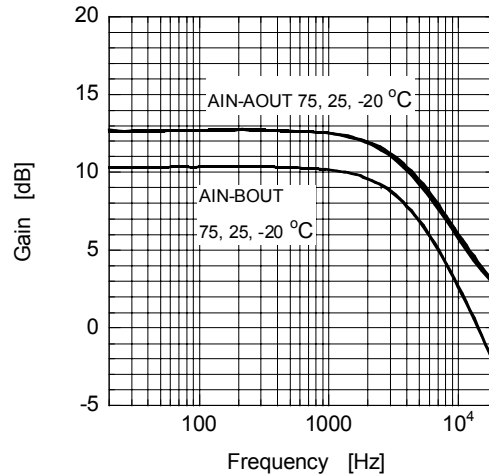

Gain vs Frequency (eala+VE)

$V+=9V, V_{in}=0.1V_{rms}, R_g=0\Omega, T_a=25^\circ C$

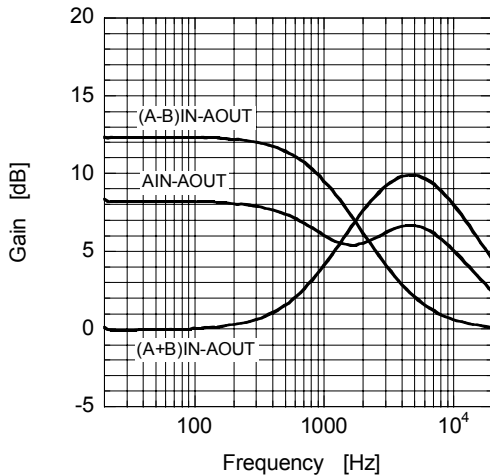

Gain vs Frequency (Surround+VE)

$V+=9V, V_{in}=0.1V_{rms}, R_g=0\Omega, T_a=25^\circ C$

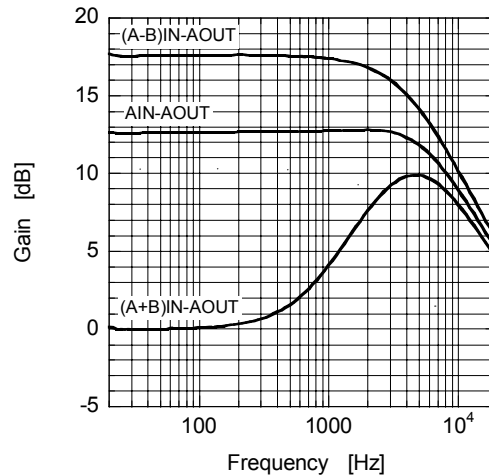

■ TYPICAL CHARACTERISTICS

Gain vs Frequency (VoiceEnhance)

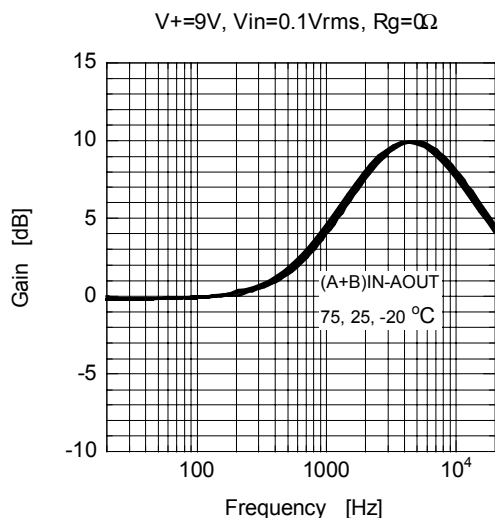

Phase vs Frequency (Surround+PS)

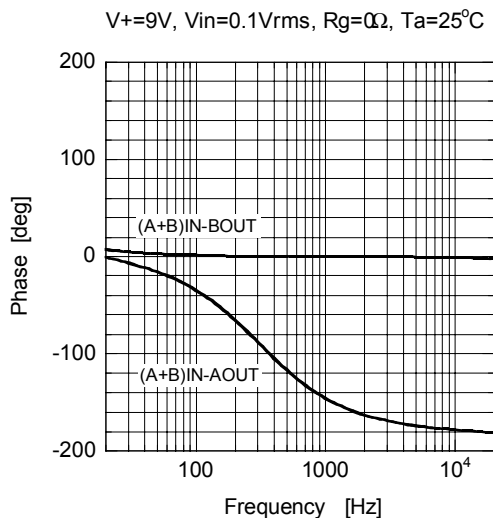

Gain vs Frequency (BassBoost)

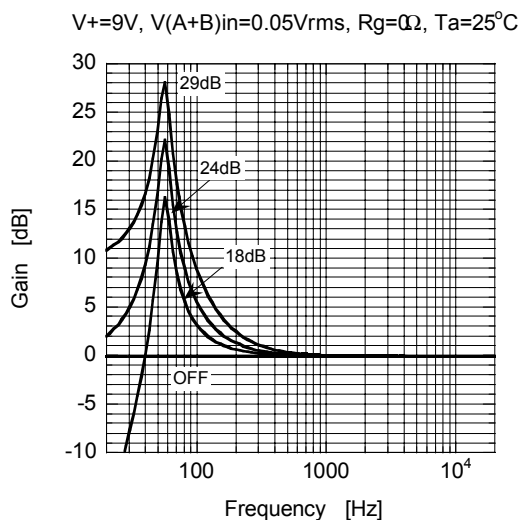

Gain vs Frequency (BassBoost)

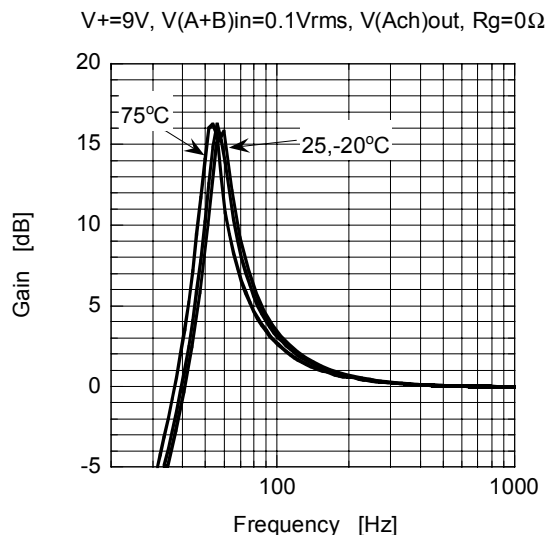

[CAUTION]

The specifications on this databook are only given for information, without any guarantee as regards either mistakes or omissions. The application circuits in this databook are described only to show representative usages of the product and not intended for the guarantee or permission of any right including the industrial rights.