

Single Phase Rectifier Bridge

PSB 35

$$I_{dAVM} = 35 \text{ A}$$

$$V_{RRM} = 800-1800 \text{ V}$$

Preliminary Data Sheet

V_{RSM} (V)	V_{RRM} (V)	Type
800	800	PSB 35/08
1200	1200	PSB 35/12
1400	1400	PSB 35/14
1600	1600	PSB 35/16
1800	1800	PSB 35/18

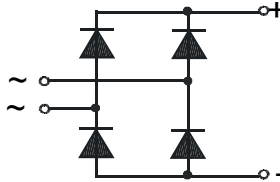

Symbol	Test Conditions	Maximum Ratings
I_{dAVM}	$T_C = 85 \text{ }^\circ\text{C}$, (per module)	35 A
I_{FSM}	$T_{VJ} = 45 \text{ }^\circ\text{C}$ $t = 10 \text{ ms}$ (50 Hz), sine	400 A
	$V_R = 0$ $t = 8.3 \text{ ms}$ (60 Hz), sine	440 A
	$T_{VJ} = T_{VJM}$ $t = 10 \text{ ms}$ (50 Hz), sine	360 A
	$V_R = 0$ $t = 8.3 \text{ ms}$ (60 Hz), sine	400 A
$\int i^2 dt$	$T_{VJ} = 45 \text{ }^\circ\text{C}$ $t = 10 \text{ ms}$ (50 Hz), sine	800 A ² s
	$V_R = 0$ $t = 8.3 \text{ ms}$ (60 Hz), sine	810 A ² s
	$T_{VJ} = T_{VJM}$ $t = 10 \text{ ms}$ (50 Hz), sine	650 A ² s
	$V_R = 0$ $t = 8.3 \text{ ms}$ (60 Hz), sine	670 A ² s
T_{VJ}		-40... + 150 $^\circ\text{C}$
T_{VJM}		150 $^\circ\text{C}$
T_{stg}		-40... + 150 $^\circ\text{C}$
V_{ISOL}	50/60 Hz, RMS $t = 1 \text{ min}$	2500 V~
	$I_{ISOL} \leq 1 \text{ mA}$ $t = 1 \text{ s}$	3000 V~
M_d	Mounting torque (M4)	1.5 Nm
	Terminal connection torque (M4)	1.5 Nm
Weight	typ.	105 g

Features

-
- Package with screw terminals
- Isolation voltage 3000 V~
- Planar glass passivated chips
- Blocking voltage up to 1800 V
- Low forward voltage drop
- UL registered E 148688

Applications

- Supplies for DC power equipment
- Input rectifier for PWM inverter
- Battery DC power supplies
- Field supply for DC motors

Advantages

- Easy to mount with two screws
- Space and weight savings
- Improved temperature and power cycling capability

Package style and outline

Dimensions in mm (1mm = 0.0394")

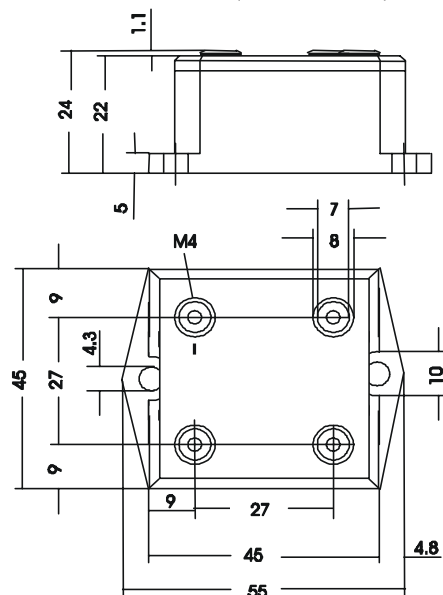

Symbol	Test Conditions	Characteristic Value
I_R	$V_R = V_{RRM}$, $T_{VJ} = 25 \text{ }^\circ\text{C}$	$\leq 0.3 \text{ mA}$
	$V_R = V_{RRM}$, $T_{VJ} = T_{VJM}$	$\leq 5 \text{ mA}$
V_F	$I_F = 150 \text{ A}$, $T_{VJ} = 25 \text{ }^\circ\text{C}$	$\leq 2.2 \text{ V}$
V_{TO}	For power-loss calculations only	0.85 V
r_T		12 m Ω
R_{thJC}	per diode; DC	2.8 K/W
	per module	0.7 K/W
R_{thJK}	per diode; DC	3.4 K/W
	per module	0.85 K/W
d_s	Creeping distance on surface	18.6 mm
d_A	Creeping distance in air	18.6 mm
a	Max. allowable acceleration	50 m/s ²

Data according to IEC 60747 refer to a single diode unless otherwise stated

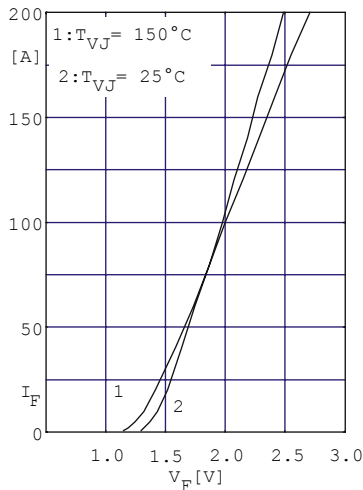

Fig. 1 Forward current versus voltage drop per diode

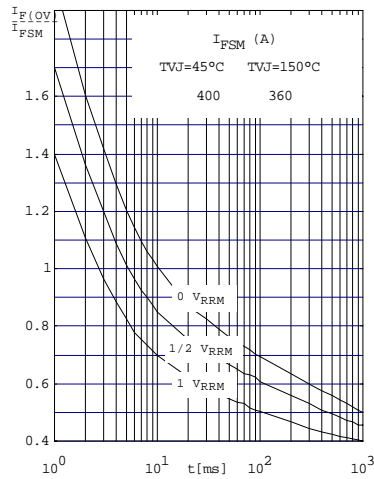

Fig. 2 Surge overload current per diode I_{FSM} : Crest value. t : duration

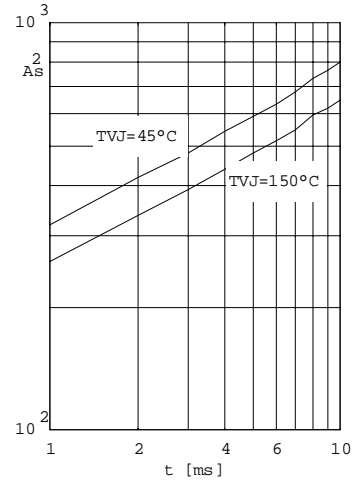

Fig. 3 $\int i^2 dt$ versus time (1-10ms) per diode (or thyristor)

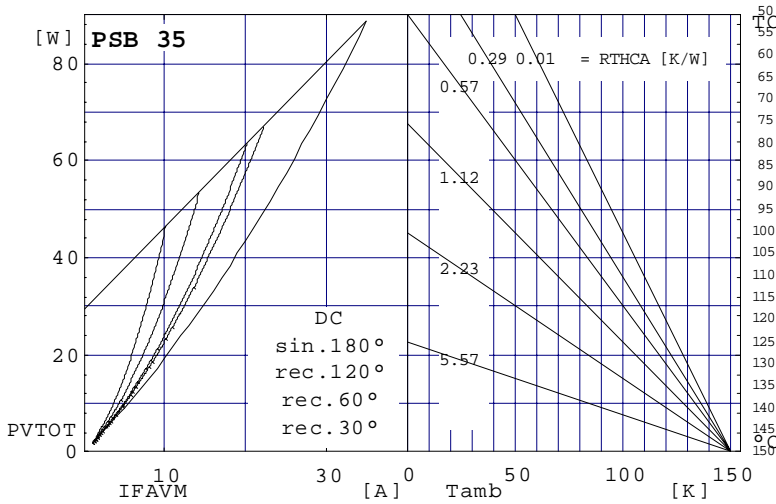

Fig. 4 Power dissipation versus direct output current and ambient temperature

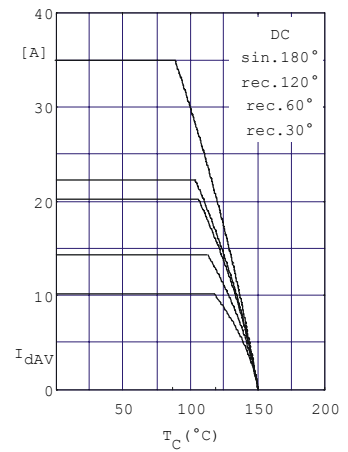

Fig. 5 Maximum forward current at case temperature

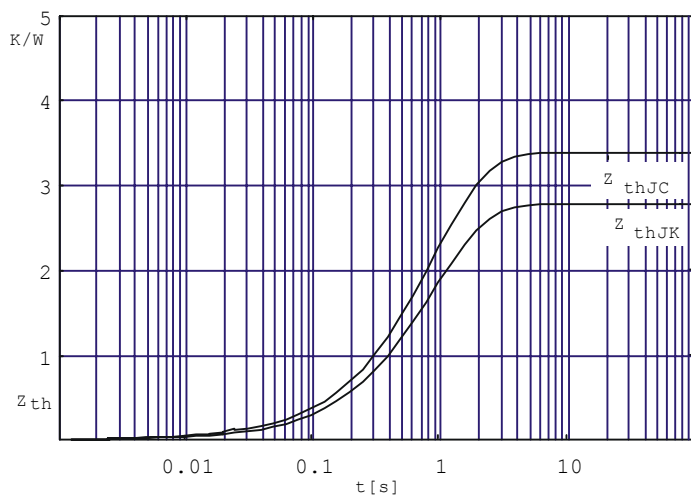

Fig. 6 Transient thermal impedance per diode (or thyristor), calculated