

Silicon NPN Power Transistors

2N5050 2N5051 2N5052

DESCRIPTION

- With TO-66 package
- High breakdown voltage
- Excellent safe operating area

APPLICATIONS

- Designed for driver circuits,switching and amplifier applications

PINNING

PIN	DESCRIPTION
1	Base
2	Emitter
3	Collector

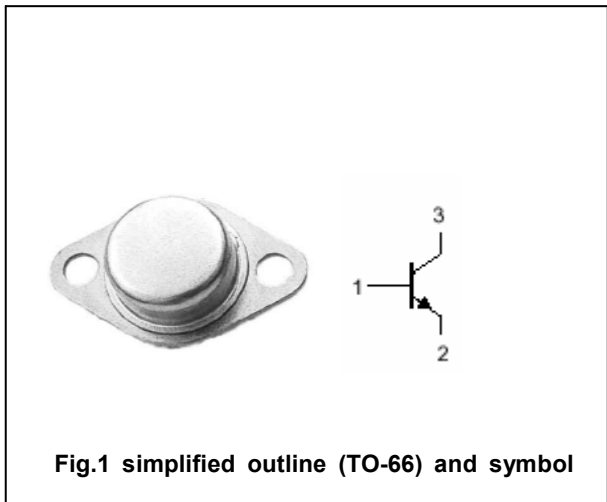

Fig.1 simplified outline (TO-66) and symbol

Absolute maximum ratings(Ta=□)

SYMBOL	PARAMETER	CONDITIONS	VALUE	UNIT
V _{CBO}	Collector-base voltage	2N5050	125	V
		2N5051	150	
		2N5052	200	
V _{CEO}	Collector-emitter voltage	2N5050	125	V
		2N5051	150	
		2N5052	200	
V _{EBO}	Emitter-base voltage	Open collector	7	V
I _C	Collector current		2	A
P _D	Total Power Dissipation	T _C =25□	40	W
T _j	Junction temperature		150	□
T _{stg}	Storage temperature		-65~200	□

THERMAL CHARACTERISTICS

SYMBOL	PARAMETER	VALUE	UNIT
R _{th j-c}	Thermal resistance junction to case	7.0	□/W

Silicon NPN Power Transistors

2N5050 2N5051 2N5052

CHARACTERISTICS

T_j=25°C unless otherwise specified

SYMBOL	PARAMETER	CONDITIONS	MIN	TYP.	MAX	UNIT
V _{CEO(SUS)}	Collector-emitter sustaining voltage	2N5050	I _C =0.1A ; I _B =0			V
		2N5051				
		2N5052				
V _{CEsat}	Collector-emitter saturation voltage	I _C =2A; I _B =0.5A			1.2	V
V _{BEsat}	Base-emitter saturation voltage	I _C =2A; I _B =0.5A			1.5	V
V _{BE}	Base-emitter on voltage	I _C =750mA ; V _{CE} =5V			1.2	V
I _{CEO}	Collector cut-off current	2N4910	V _{CE} =125V; I _B =0			mA
		2N4911				
		2N4912				
I _{CBO}	Collector cut-off current	V _{CB} =Rated V _{CBO} ; I _E =0			0.1	mA
I _{EBO}	Emitter cut-off current	V _{EB} =7V; I _C =0			1.0	mA
h _{FE}	DC current gain	I _C =750mA ; V _{CE} =5V	25		100	
f _T	Transition frequency	I _C =500mA; V _{CE} =10V; f=1MHz		10		MHz

Silicon NPN Power Transistors

2N5050 2N5051 2N5052

PACKAGE OUTLINE

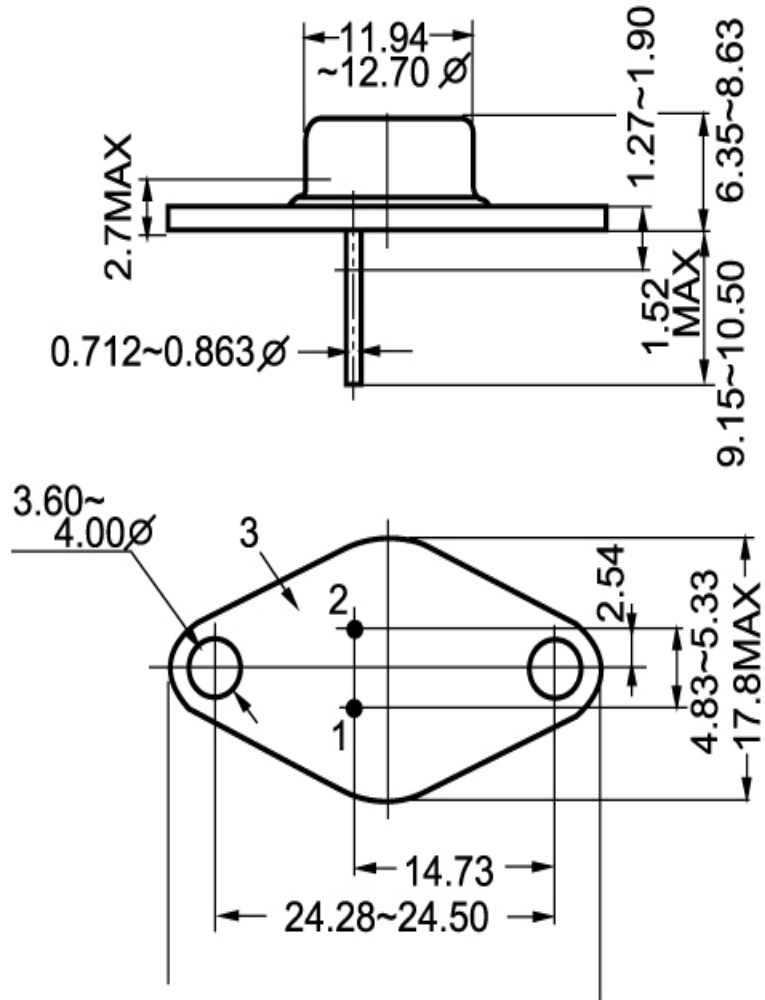

Fig.2 outline dimensions