

Adjustable Precision Shunt Regulator

Features

- Precise Reference Voltage to 2.500V
- Guaranteed 0.5% or 1% Reference Voltage Tolerance
- Sink Current Capability , 1mA to 100mA
- Quick Turn-on
- Adjustable Output Voltage , $V_O = V_{REF}$ to 20V
- Low Operational Cathode Current , 250 μ A Typical
- 0.1 Ω Typical Output Impedance
- SOT-23 , SOT-89 and TO-92 Packages
- Lead Free and Green Devices Available (RoHS Compliant)

Applications

- Linear Regulators
- Adjustable Power Supply
- Switching Power Supply

Symbol

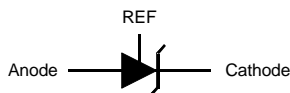

Functional Diagram

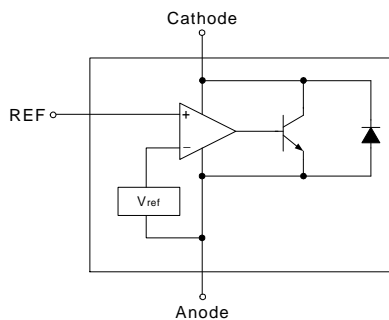

General Description

The APL1431 is a 3-terminal adjustable voltage reference with specified thermal stability over applicable commercial temperature ranges. Output voltage may be set to any value between V_{REF} (2.5 V) and 20 V with two external resistors (see Figure 2). When used with an photocoupler, the APL1431 is an ideal voltage reference in isolated feedback circuits for 2.5V to 12V switching-mode power supplies. This device has a typical output impedance of 0.1 Ω . Active output circuitry provides a very sharp turn-on characteristic, making the APL1431 excellent replacements for zener diodes in many applications, including on-board regulation and adjustable power supplies.

Pin Configuration

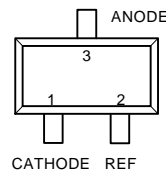

SOT-23 (Top View)

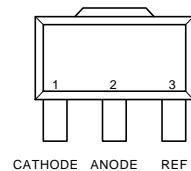

SOT-89 (Top View)

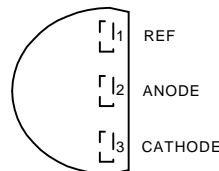

TO-92 (Top View)

ANPEC reserves the right to make changes to improve reliability or manufacturability without notice, and advise customers to obtain the latest version of relevant information to verify before placing orders.

Ordering and Marking Information

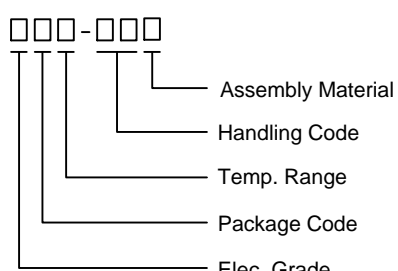
<p>APL1431 □□□-□□□</p>  <p>Assembly Material Handling Code Temp. Range Package Code Elec. Grade</p>	<p>Elec. Grade A : 0.5% Reference Voltage Tolerance B : 1% Reference Voltage Tolerance</p> <p>Package Code A : SOT-23 D : SOT-89 E : TO-92 Y : Chip Form</p> <p>Temp. Range C : 0 to 70 °C I : -40 to 85 °C</p> <p>Handling Code TB : Tape & Box TR : Tape & Reel</p> <p>Assembly Material L : Lead Free Device G : Halogen and Lead Free Device</p>
<p>APL1431 A : □1431</p>	<p>APL1431 E : □APL □1431 □XXXXX XXXXX - Date Code</p>
<p>APL1431 D : □APL1431 □XXXXX XXXXX - Date Code</p>	

Note: ANPEC lead-free products contain molding compounds/die attach materials and 100% matte tin plate termination finish; which are fully compliant with RoHS. ANPEC lead-free products meet or exceed the lead-free requirements of IPC/JEDEC J-STD-020C for MSL classification at lead-free peak reflow temperature. ANPEC defines "Green" to mean lead-free (RoHS compliant) and halogen free (Br or Cl does not exceed 900ppm by weight in homogeneous material and total of Br and Cl does not exceed 1500ppm by weight).

Absolute Maximum Ratings

Symbol	Parameter	Rating	Unit	
V_{KA}	Cathode Voltage	21	V	
I_K	Continuous Cathode Current Range	120	mA	
I_{REF}	Reference Current Range	3	mA	
θ_{JA}	Thermal Resistance from Junction to Ambient in Free Air		°C/W	
	SOT-23	416		
	SOT-89	250		
	TO-92	250		
T_A	Ambient Temperature Range	APL1431XXC APL1431XXI	0 to 70 -40 to 85	°C
T_j	Junction Temperature Range	APL1431XXC APL1431XXI	0 to 150 -40 to 150	°C
T_{STG}	Storage Temperature Range		-65 to 150	°C
T_{SDR}	Maximum Lead Soldering Temperature, 10 Seconds		260	°C

Electrical Characteristics $T_A = 25^\circ\text{C}$ (unless otherwise noted)

Symbol	Parameter	Test Conditions	APL1431			Unit
			Min.	Typ.	Max.	
V_{REF}	Reference Voltage	$V_{KA}=V_{REF}, I_K=10\text{mA}$ APL431A APL431B	2.487 2.475	2.500	2.513 2.525	V
$\Delta V_{REF}/T$	Reference Voltage Drift Over Temp. Range	$V_{KA}=V_{REF}, I_K=10\text{mA}$ $T_A = 0 \text{ to } 70^\circ\text{C}^{*1}$ $T_A = -40 \text{ to } 85^\circ\text{C}^{*1}$			20 30	mV
$\Delta V_{REF} / \Delta V_{KA}$	Voltage Ratio (open loop gain)	$I_K=10\text{mA}, V_{KA}=V_{REF} \text{ to } 10V^{*2}$ $I_K=10\text{mA}, V_{KA}=V_{REF} \text{ to } 20V^{*2}$		-1.5 -1.2	-3 -2.5	mV/V

Electrical Characteristics (Cont.) $T_A = 25^\circ\text{C}$ (unless otherwise noted)

Symbol	Parameter	Test Conditions	APL1431			Unit
			Min.	Typ.	Max.	
I_{REF}	Reference Current	$I_K=10\text{mA}$, $R_1=10\text{k}\Omega$, $R_2=\text{open}^{*2}$		1.0	3	μA
$\Delta I_{REF}/T$	Reference Current Drift	$I_K=10\text{mA}$, $R_1=10\text{k}\Omega$, $R_2=\text{open}$, $T_A = -40$ to 85°C^{*2}		0.3	1	μA
$I_{K(\text{min})}$	Min. Cathode Current	$V_{KA}=V_{REF}^{*1}$		0.25	0.5	mA
$I_{K(\text{off})}$	Off-state Cathode Current	$V_{KA}= 20\text{V}$, $V_{REF}= 0\text{V}^{*3}$		0.1	1	μA
$ Z_{KA} $	Dynamic Impedance	$V_{KA}=V_{REF}$ $I_K=1\text{mA}$ to 100mA , $f \leq 1\text{kHz}^{*1}$		0.1	0.4	Ω
I_K	Cathode Current				100	mA

- Notes : *1 : use Figure 1
 *2 : use Figure 2
 *3 : use Figure 3

Test figures

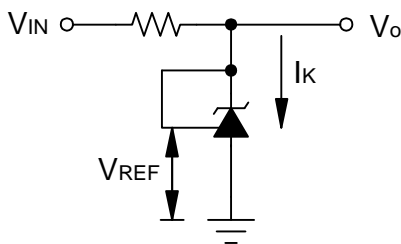

Figure 1. Test Circuit for $V_{KA}=V_{REF}$, $V_O=V_{KA}=V_{REF}$

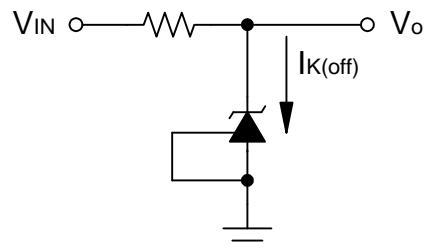

Figure 3. Test Circuit for $I_{K(\text{off})}$

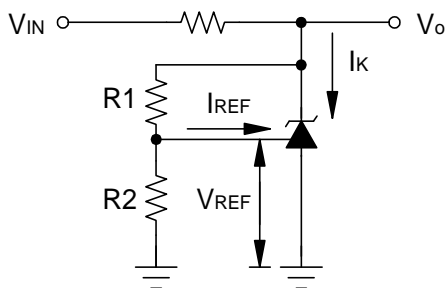
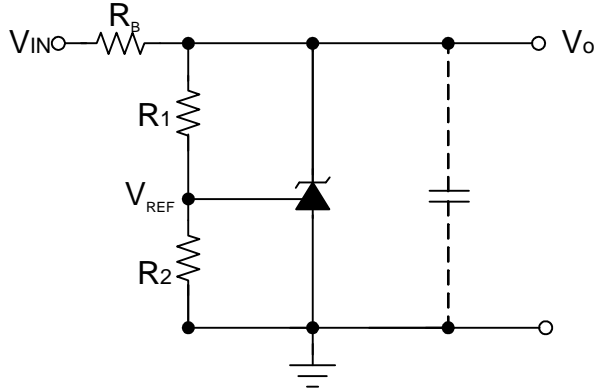
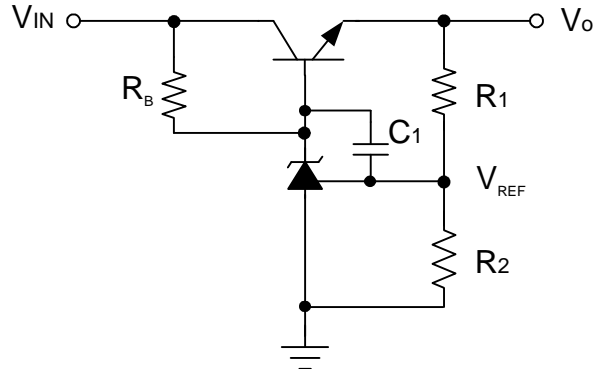

Figure 2. Test Circuit for $V_{KA}>V_{REF}$
 $V_O = V_{KA} = V_{REF} \times (1+R_1/R_2) + I_{REF} \times R_1$

Application Circuits



Precision Voltage Reference



Precision High-Current Series Regulator

Notes for Application Circuits:

- 1) For the series regulator applications, add a compensation capacitor C1 between CATHODE and REF is strongly recommended to improve the stability of output voltage .
- 2) Set V_o according to the following equation: $V_o = V_{REF}(1+R1/R2)+I_{REF} \times R1$
- 3) Choose the value for R_B as follows:
 - A) The maximum limit for R_B should be such that the cathode current (I_k) is greater than the minimum operating current (0.5mA) at $V_{IN(MIN)}$.
 - B) The minimum limit for R_B should be such that the cathode current (I_k) does not exceed 100mA under all load conditions, and the instantaneous turn-on value for I_k does not exceed 120mA.

Typical Characteristics

Reference Input Current vs. Ambient Temperature

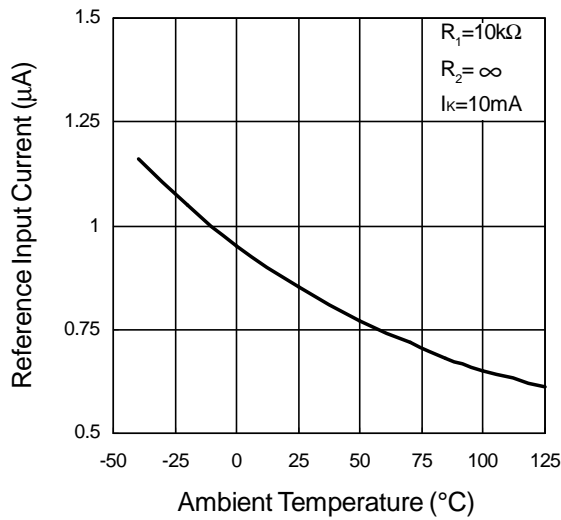

Cathode Current vs. Cathode Voltage

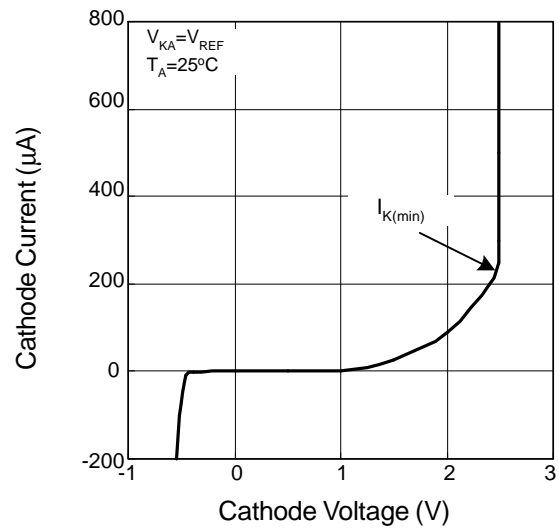

Cathode Current vs. Cathode Voltage

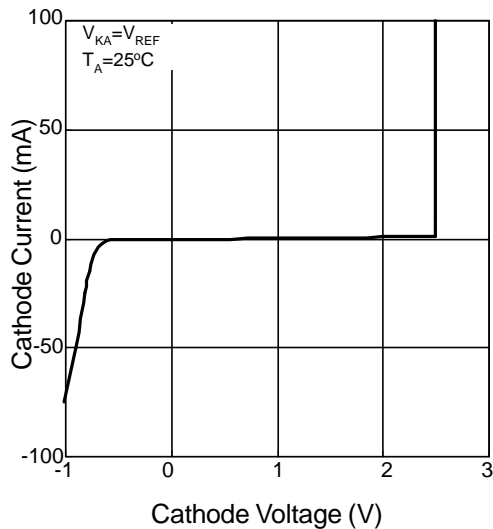

Reference Voltage vs. Ambient Temperature

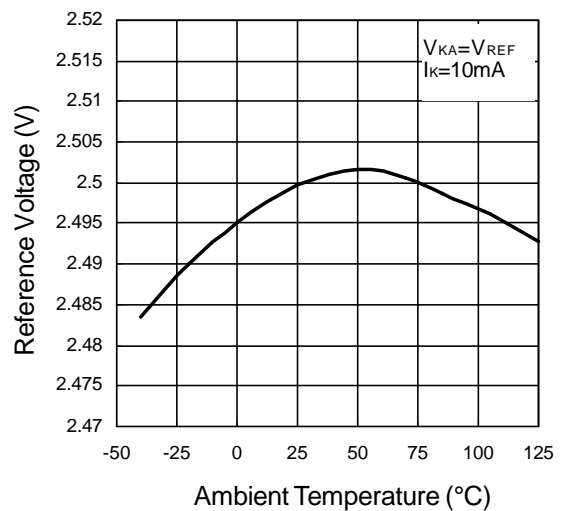

Typical Characteristics (Cont.)

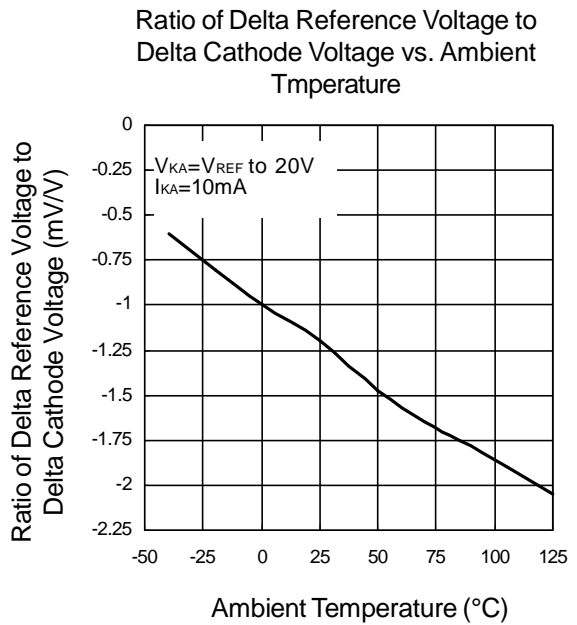
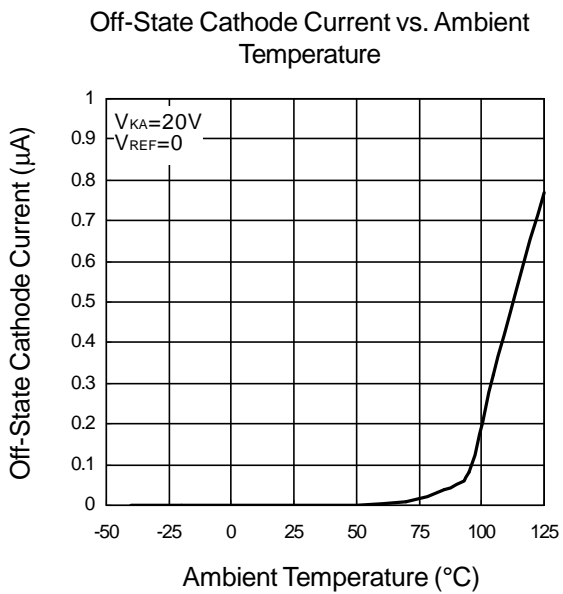
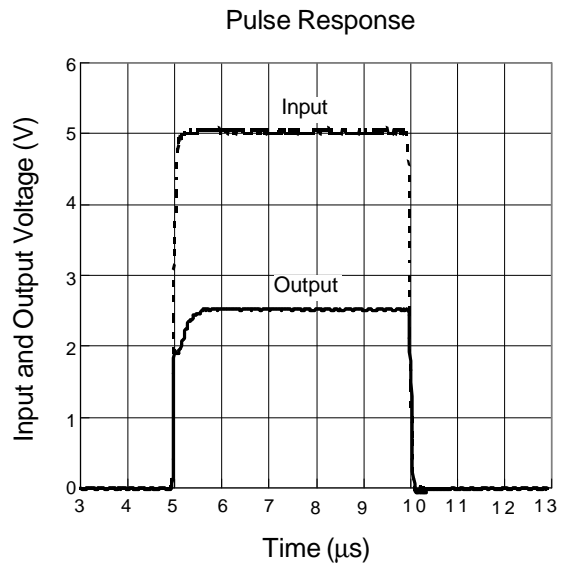
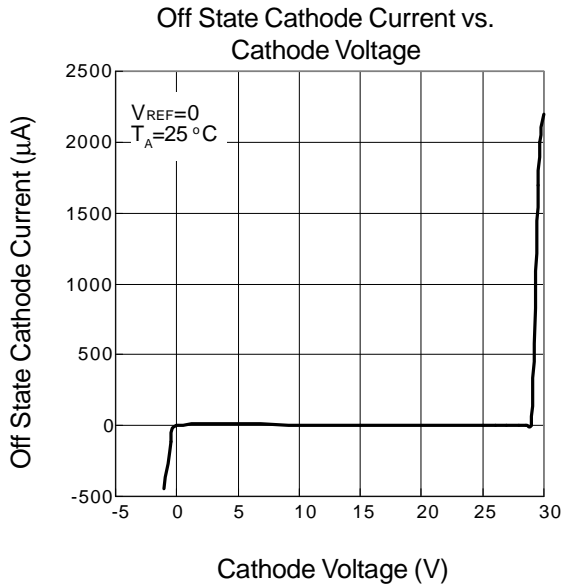

Typical Characteristics (Cont.)

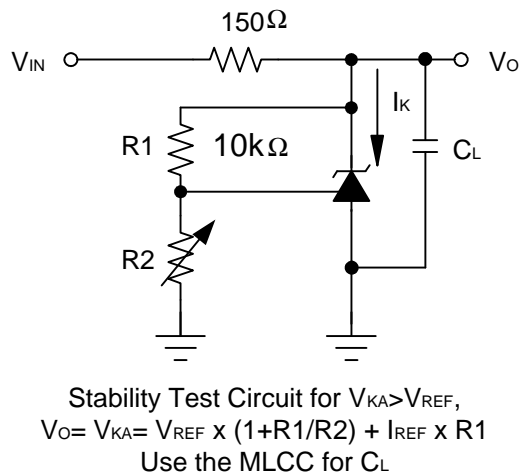
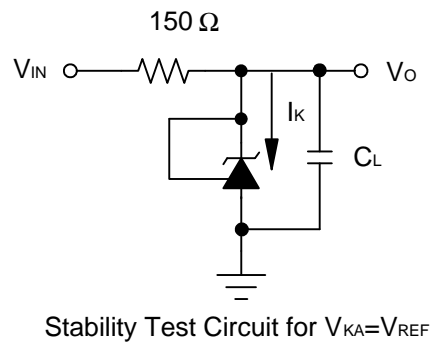
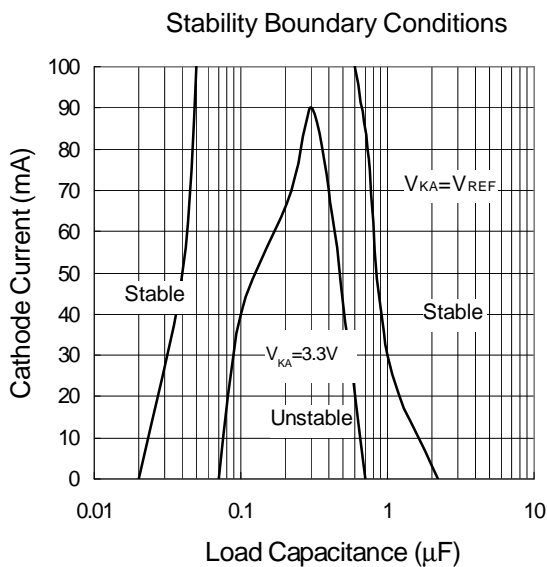
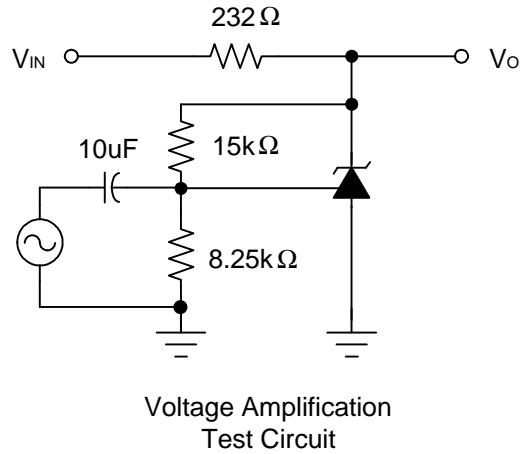
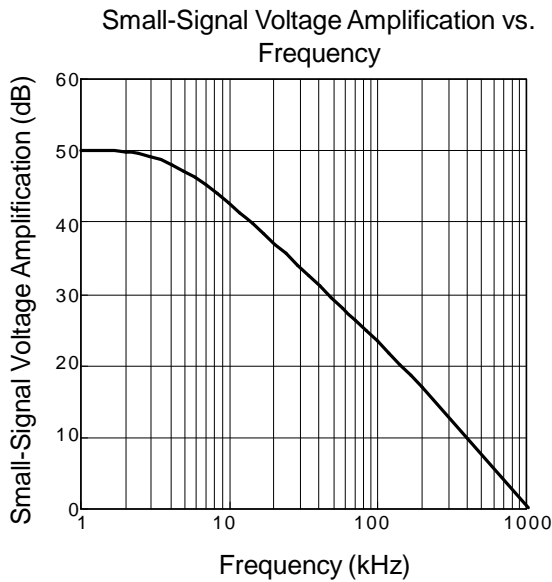

Typical Characteristics (Cont.)

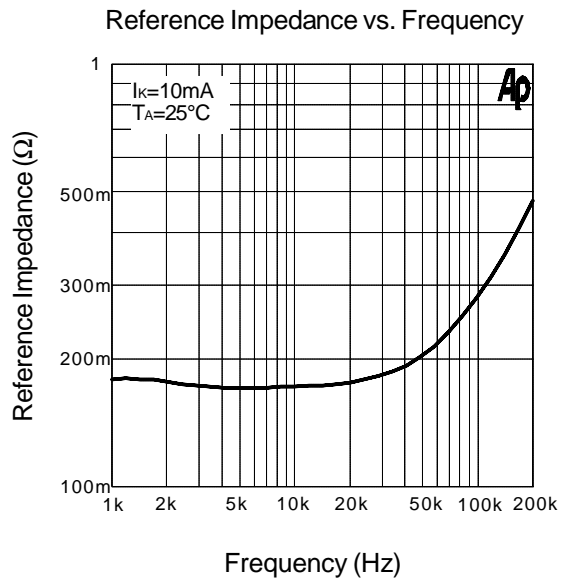

Package Information

SOT-23-3

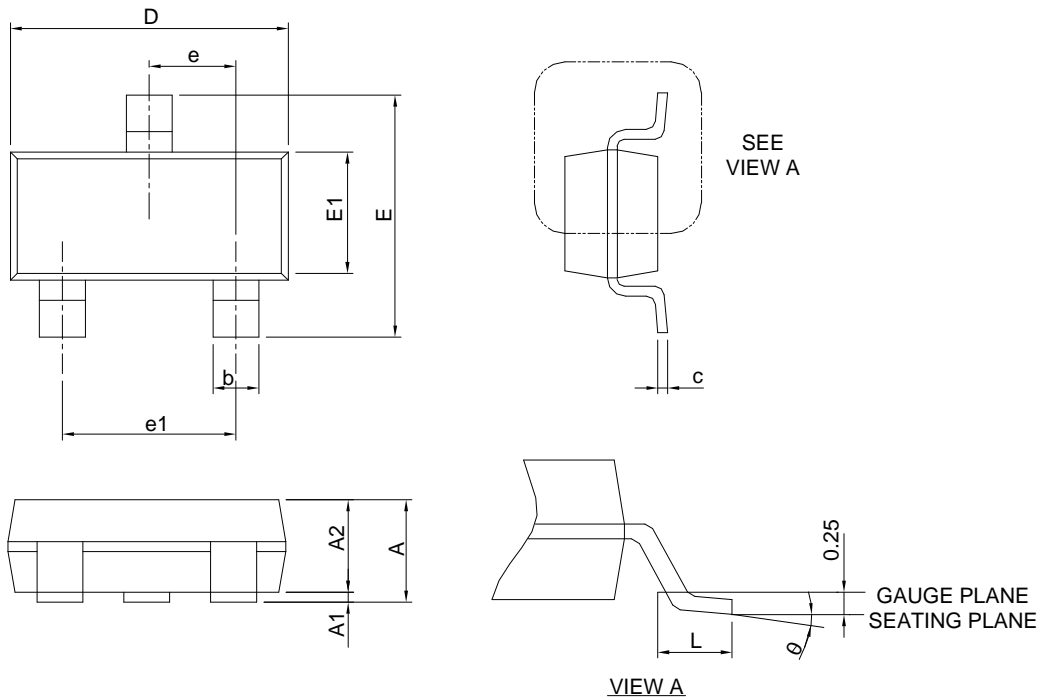

SYMBOLS	SOT-23			
	MILLIMETERS		INCHES	
	MIN.	MAX.	MIN.	MAX.
A		1.45		0.057
A1	0.00	0.15	0.000	0.006
A2	0.90	1.30	0.035	0.051
b	0.30	0.50	0.012	0.020
c	0.08	0.22	0.003	0.009
D	2.70	3.10	0.106	0.122
E	2.60	3.00	0.102	0.118
E1	1.40	1.80	0.055	0.071
e	0.95 BSC		0.037 BSC	
e1	1.90 BSC		0.075 BSC	
L	0.30	0.60	0.012	0.024
θ	0°	8°	0°	8°

Note : Dimension D and E1 do not include mold flash, protrusions or gate burrs. Mold flash, protrusion or gate burrs shall not exceed 10 mil per side.

Package Information

SOT-89

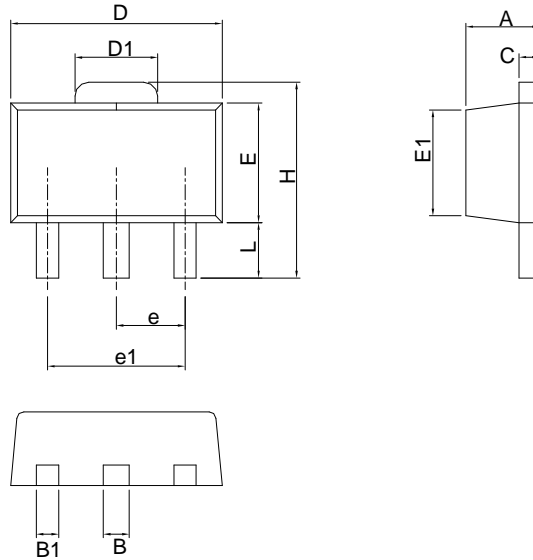

SYMBOL	SOT-89			
	MILLIMETERS		INCHES	
	MIN.	MAX.	MIN.	MAX.
A	1.40	1.60	0.055	0.063
B	0.44	0.56	0.017	0.022
B1	0.36	0.48	0.014	0.019
C	0.35	0.44	0.014	0.017
D	4.40	4.60	0.173	0.181
D1	1.62	1.83	0.064	0.072
E	2.29	2.60	0.090	0.102
E1	2.13	2.29	0.084	0.090
e	1.50 BSC		0.059 BSC	
e1	3.00 BSC		0.118 BSC	
H	3.94	4.25	0.155	0.167
L	0.89	1.20	0.035	0.047

Note : Follow JEDEC TO-243 AA.

Package Information

TO-92

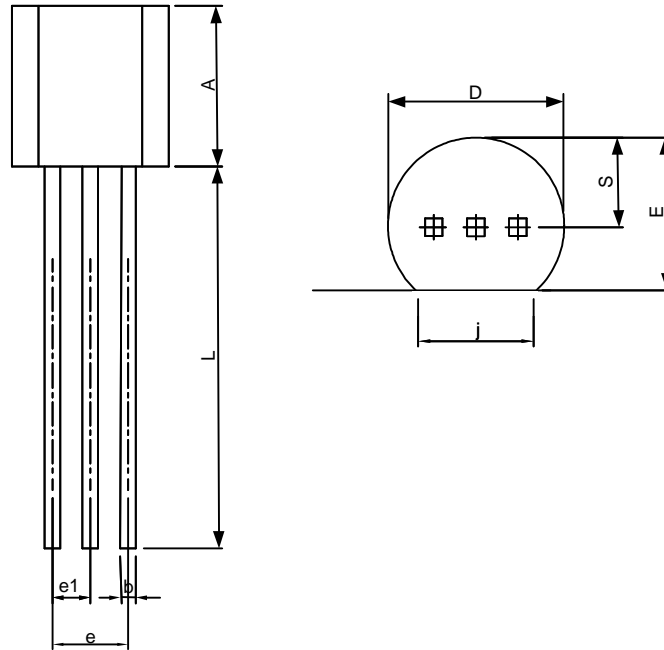

SYMBOL	TO-92			
	MILLIMETERS		INCHES	
	MIN.	MAX.	MIN.	MAX.
A	4.32	5.33	0.170	0.210
b	0.41	0.53	0.016	0.021
D	4.45	5.20	0.175	0.205
E	3.18	4.19	0.125	0.165
e	2.42	2.66	0.095	0.105
e1	1.15	1.39	0.045	0.055
j	3.43	4.00	0.135	0.157
L	12.70	15.00	0.500	0.591
S	2.03	2.66	0.080	0.105

Note : Follow JEDEC TO-92.

Carrier Tape & Reel Dimensions

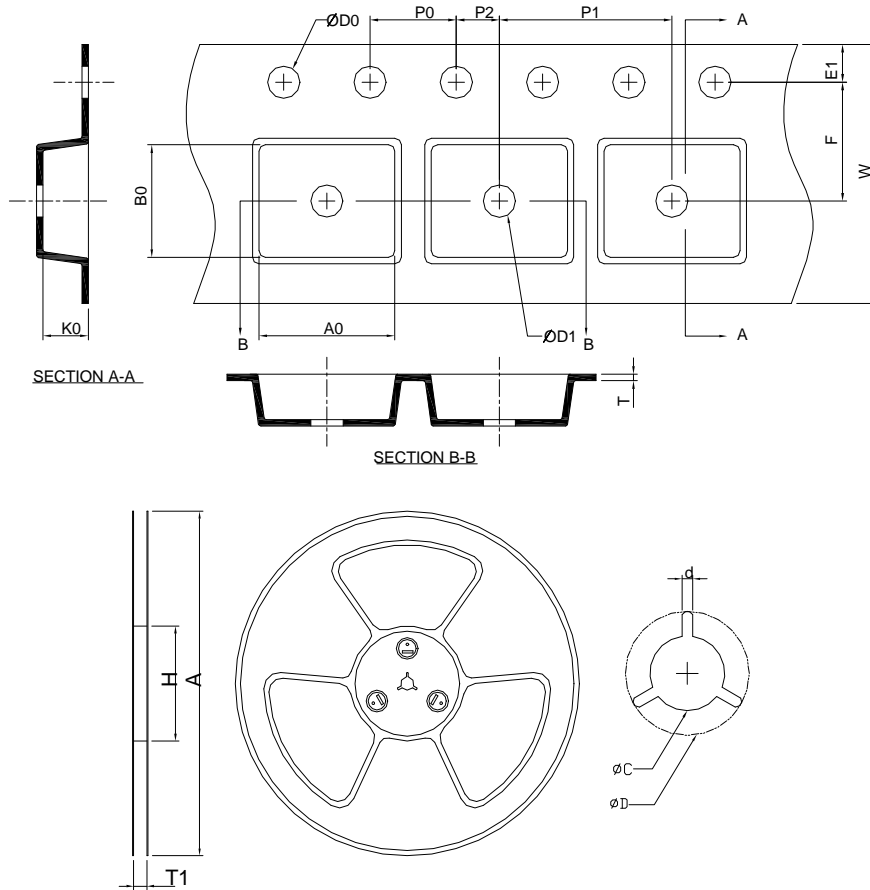

Application	A	H	T1	C	d	D	W	E1	F
SOT-23-3	178.0 ±0.00	50 MIN.	8.4+2.00 -0.00	13.0+0.50 -0.20	1.5 MIN.	20.2 MIN.	8.0 ±0.30	1.75 ±0.10	3.5 ±0.05
	P0	P1	P2	D0	D1	T	A0	B0	K0
	4.0 ±0.10	4.0 ±0.10	2.0 ±0.10	1.5+0.10 -0.00	1.5 MIN.	0.6+0.00 -0.40	3.20 ±0.20	3.10 ±0.20	1.50 ±0.20
Application	A	H	T1	C	d	D	W	E1	F
SOT-89	178.0 ±0.00	50 MIN.	8.4+2.00 -0.00	13.0+0.50 -0.20	1.5 MIN.	20.2 MIN.	12.0 ±0.30	1.75 ±0.10	5.50 ±0.05
	P0	P1	P2	D0	D1	T	A0	B0	K0
	4.0 ±0.10	8.0 ±0.10	2.0 ±0.10	1.5+0.10 -0.00	1.5 MIN.	0.6+0.00 -0.40	4.80 ±0.20	4.50 ±0.20	1.80 ±0.20

(mm)

Carrier Tape & Box Dimensions

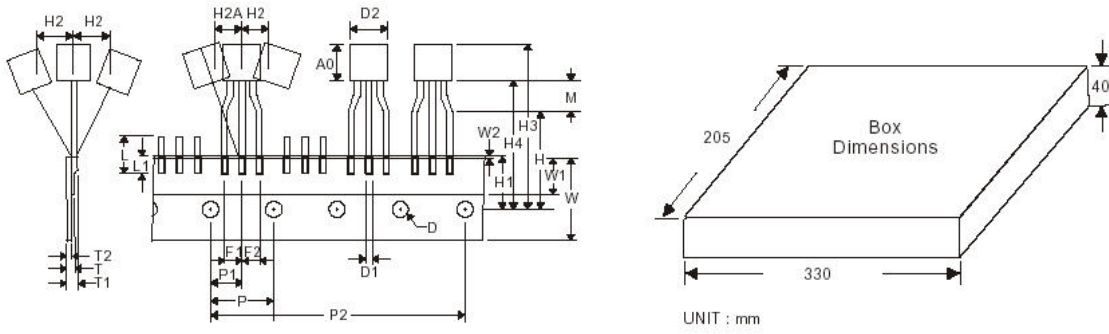

Reflow Condition (IR/Convection or VPR Reflow)

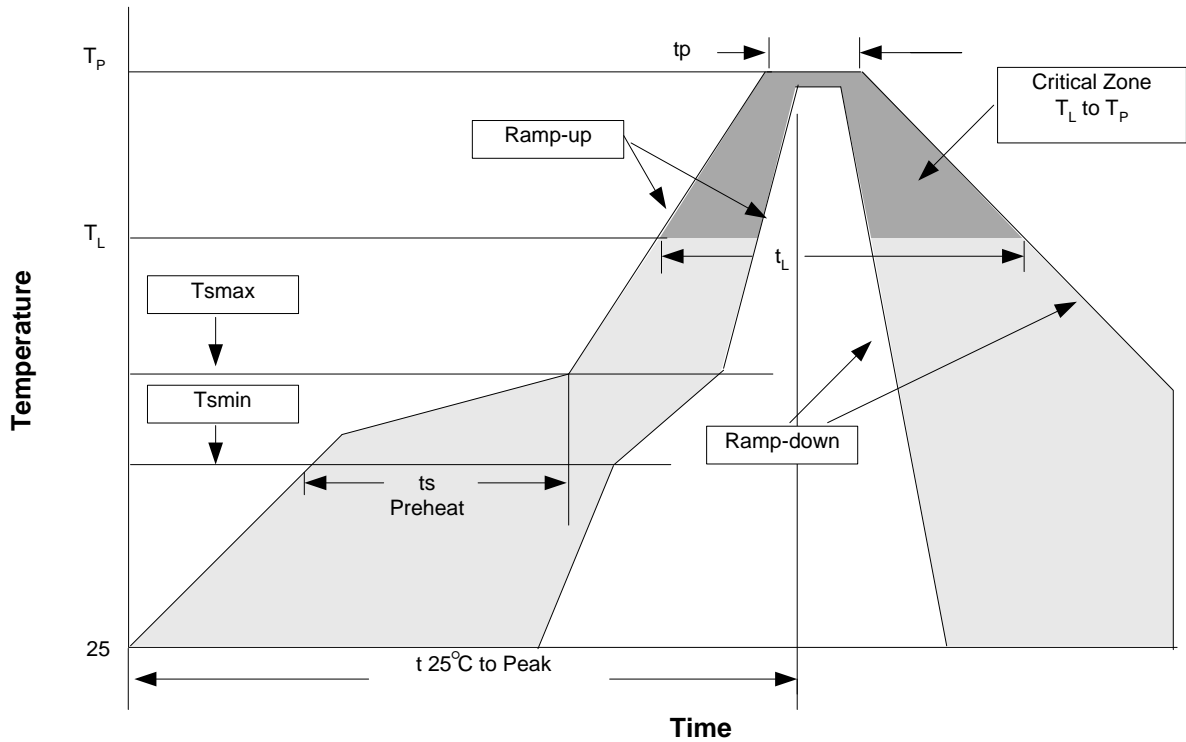

Devices Per Unit

Package Type	Unit	Quantity
SOT-23-3	Tape & Reel	3000
SOT-89	Tape & Reel	1000
TO-92	Tape & Box	2000

Reliability Test Program

Test item	Method	Description
SOLDERABILITY	MIL-STD-883D-2003	245°C, 5 sec
HOLT	MIL-STD-883D-1005.7	1000 Hrs Bias @125°C
PCT	JESD-22-B, A102	168 Hrs, 100%RH, 121°C
TST	MIL-STD-883D-1011.9	-65°C~150°C, 200 Cycles
ESD	MIL-STD-883D-3015.7	VHBM > 2KV, VMM > 200V
Latch-Up	JESD 78	10ms, 1 _{tr} > 100mA

Classification Reflow Profiles

Profile Feature	Sn-Pb Eutectic Assembly	Pb-Free Assembly
Average ramp-up rate (T _L to T _P)	3°C/second max.	3°C/second max.
Preheat		
- Temperature Min (T _{smin})	100°C	150°C
- Temperature Max (T _{smax})	150°C	200°C
- Time (min to max) (t _s)	60-120 seconds	60-180 seconds
Time maintained above:		
- Temperature (T _L)	183°C	217°C
- Time (t _L)	60-150 seconds	60-150 seconds
Peak/Classification Temperature (T _p)	See table 1	See table 2
Time within 5°C of actual Peak Temperature (t _p)	10-30 seconds	20-40 seconds
Ramp-down Rate	6°C/second max.	6°C/second max.
Time 25°C to Peak Temperature	6 minutes max.	8 minutes max.

Note: All temperatures refer to topside of the package. Measured on the body surface.

Classification Reflow Profiles (Cont.)

Table 1. SnPb Eutectic Process – Package Peak Reflow Temperatures

Package Thickness	Volume mm ³ <350	Volume mm ³ ≥350
<2.5 mm	240 +0/-5°C	225 +0/-5°C
≥2.5 mm	225 +0/-5°C	225 +0/-5°C

Table 2. Pb-free Process – Package Classification Reflow Temperatures

Package Thickness	Volume mm ³ <350	Volume mm ³ 350-2000	Volume mm ³ >2000
<1.6 mm	260 +0°C*	260 +0°C*	260 +0°C*
1.6 mm – 2.5 mm	260 +0°C*	250 +0°C*	245 +0°C*
≥2.5 mm	250 +0°C*	245 +0°C*	245 +0°C*

* Tolerance: The device manufacturer/supplier **shall** assure process compatibility up to and including the stated classification temperature (this means Peak reflow temperature +0°C. For example 260°C+0°C) at the rated MSL level.

Customer Service

Anpec Electronics Corp.

Head Office :

No.6, Dusing 1st Road, SBIP,

Hsin-Chu, Taiwan, R.O.C.

Tel : 886-3-5642000

Fax : 886-3-5642050

Taipei Branch :

2F, No. 11, Lane 218, Sec 2 Jhongsing Rd.,

Sindian City City, Taipei County 23146, Taiwan

Tel : 886-2-2910-3838

Fax : 886-2-2917-3838