

# 16-Mbit (1M x 16) Pseudo Static RAM

## Features

- **Wide voltage range: 1.7V–1.95V**
- **Access Time: 70 ns**
- **Ultra-low active power**
  - Typical active current: 3 mA @ f = 1 MHz
  - Typical active current: 18 mA @ f = f<sub>max</sub>
- **Ultra low standby power**
- **Automatic power-down when deselected**
- **CMOS for optimum speed/power**
- **Available in 48-ball BGA package**
- **Operating Temperature: –40°C to +85°C**

## Functional Description<sup>[1]</sup>

The CYU01M16SFE is a high-performance CMOS Pseudo Static RAM organized as 1M words by 16 bits that supports an asynchronous memory interface. This device features advanced circuit design to provide ultra-low active current. This is ideal for providing More Battery Life™ (MoBL®) in

portable applications such as cellular telephones. The device can be put into standby mode when deselected ( $\overline{CE}_1$  HIGH or  $CE_2$  LOW or both BHE and BLE are HIGH). The input/output pins (I/O<sub>0</sub> through I/O<sub>15</sub>) are placed in a high-impedance state when: deselected ( $\overline{CE}_1$  HIGH or  $CE_2$  LOW), outputs are disabled (OE HIGH), both Byte High Enable and Byte Low Enable are disabled ( $\overline{BHE}$ ,  $\overline{BLE}$  HIGH), or during a write operation ( $\overline{CE}_1$  LOW and  $CE_2$  HIGH and WE LOW).

To write to the device, take Chip Enable ( $\overline{CE}_1$  LOW and  $CE_2$  HIGH) and Write Enable (WE) input LOW. If Byte Low Enable (BLE) is LOW, then data from I/O pins (I/O<sub>0</sub> through I/O<sub>7</sub>), is written into the location specified on the address pins (A<sub>0</sub> through A<sub>19</sub>). If Byte High Enable ( $\overline{BHE}$ ) is LOW, then data from I/O pins (I/O<sub>8</sub> through I/O<sub>15</sub>) is written into the location specified on the address pins (A<sub>0</sub> through A<sub>19</sub>).

To read from the device, take Chip Enables ( $\overline{CE}_1$  LOW and  $CE_2$  HIGH) and Output Enable (OE) LOW while forcing the Write Enable (WE) HIGH. If Byte Low Enable (BLE) is LOW, then data from the memory location specified by the address pins will appear on I/O<sub>0</sub> to I/O<sub>7</sub>. If Byte High Enable ( $\overline{BHE}$ ) is LOW, then data from memory will appear on I/O<sub>8</sub> to I/O<sub>15</sub>. Refer to the truth table for a complete description of read and write modes.

## Logic Block Diagram

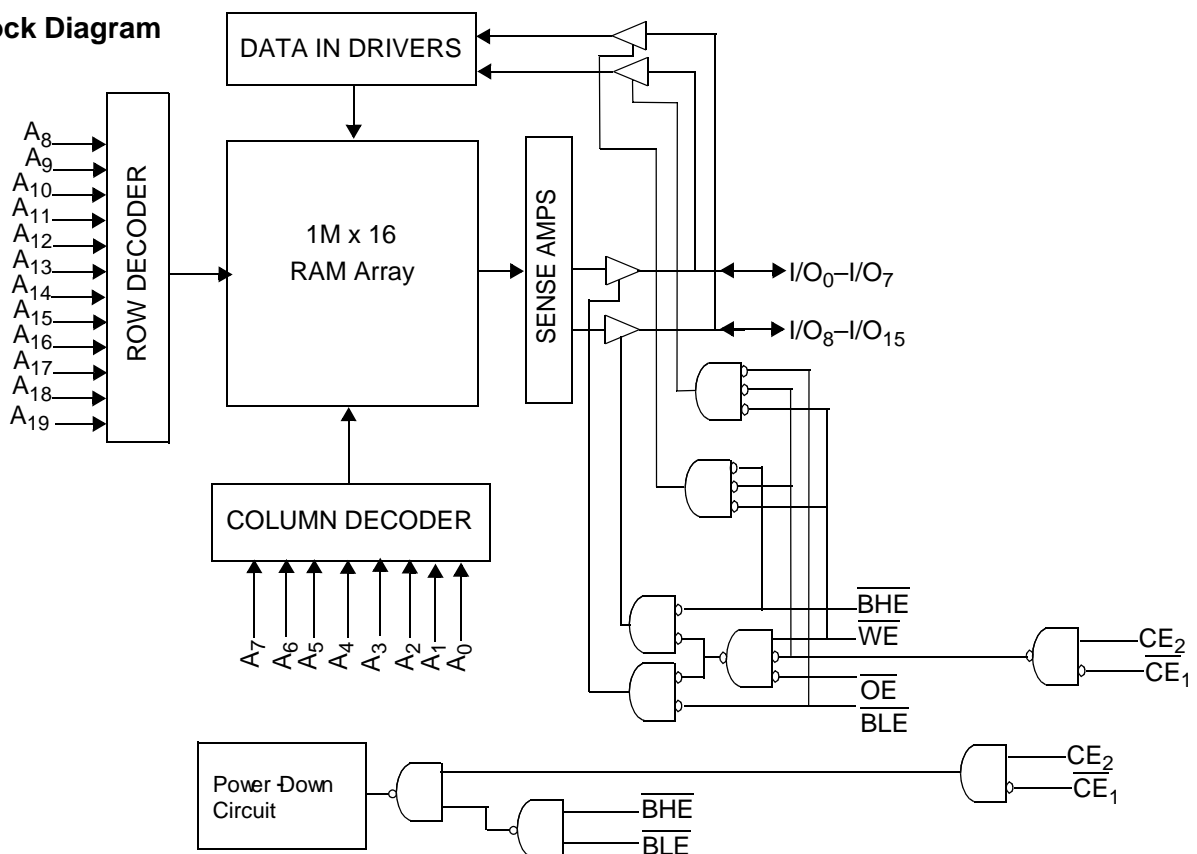

**Note:**

1. For best-practice recommendations, please refer to the Cypress application note "System Design Guidelines" on <http://www.cypress.com>.

**Pin Configuration<sup>[2, 3]</sup>**

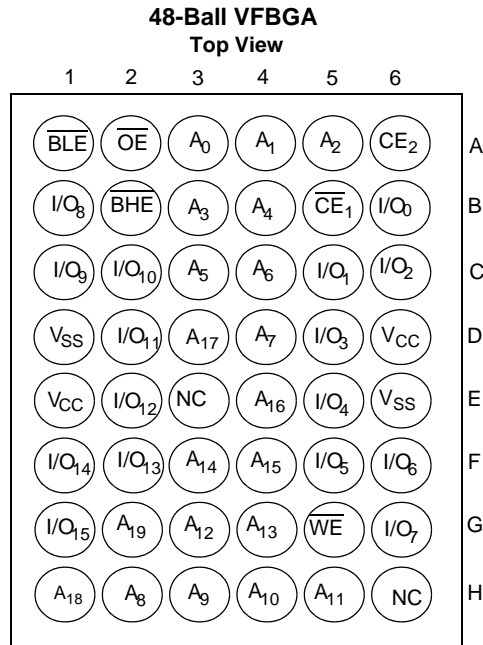

**Product Portfolio<sup>[4]</sup>**

Product	V <sub>CC</sub> Range (V)			Speed (ns)	Power Dissipation					
					Operating I <sub>CC</sub> (mA)				Standby I <sub>SB2</sub> (μA)	
					f = 1MHz		f = f <sub>max</sub>			
Min.	Typ. <sup>[4]</sup>	Max.	Typ. <sup>[4]</sup>	Max.	Typ. <sup>[4]</sup>	Max.	Typ. <sup>[4]</sup>	Max.		
CYU01M16SFE	1.7	1.8	1.95	70	3	5	18	20	55	70

**Power-up Characteristics**

The initialization sequence is shown in the figure below. Chip Select should be  $\overline{CE}_1$  HIGH or  $CE_2$  LOW for at least 200 μs after V<sub>CC</sub> has reached a stable value. No access must be attempted during this period of 200 μs.

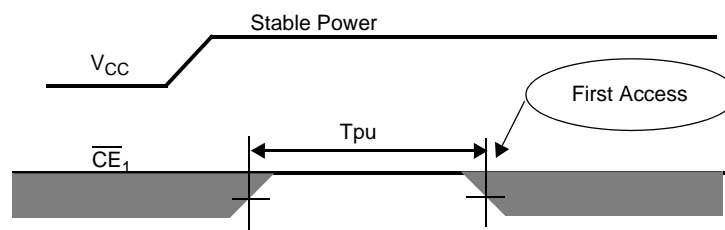

Parameter	Description	Min.	Typ.	Max.	Unit
T <sub>pu</sub>	Chip Enable Low After Stable V <sub>CC</sub>	200			μs

**Notes:**

2. Ball H6 and E3 can be used to upgrade to a 32-Mbit and a 64-Mbit density, respectively.
3. NC "no connect"-not connected internally to the die.
4. Typical values are included for reference only and are not guaranteed or tested. Typical values are measured at V<sub>CC</sub> = V<sub>CC</sub> (typ) and T<sub>A</sub> = 25°C. Tested initially and after design changes that may affect the parameters.



**Maximum Ratings**

(Above which the useful life may be impaired. For user guidelines, not tested.)

Storage Temperature ..... -65°C to +150°C  
 Ambient Temperature with Power Applied..... -55°C to +125°C  
 Supply Voltage to Ground Potential. -0.2V to  $V_{CCMAX} + 0.3V$   
 DC Voltage Applied to Outputs in High Z State<sup>[5, 6, 7]</sup> ..... -0.2V to  $V_{CCMAX} + 0.3V$

DC Input Voltage<sup>[5, 6, 7]</sup>..... -0.2V to  $V_{CCMAX} + 0.3V$   
 Output Current into Outputs (LOW)..... 20 mA  
 Static Discharge Voltage..... > 2001V (per MIL-STD-883, Method 3015)  
 Latch-Up Current..... > 200 mA

Device	Range	Operating Temperature (T <sub>A</sub> )	V <sub>CC</sub>
CYU01M16SFE	Industrial	-40°C to +85°C	1.7V to 1.95V

**DC Electrical Characteristics** (Over the Operating Range) <sup>[5, 6, 7]</sup>

Parameter	Description	Test Conditions	CYU01M16SFE-70 ns			Unit
			Min.	Typ. <sup>[4]</sup>	Max.	
V <sub>CC</sub>	Supply Voltage		1.7	1.8	1.95	V
V <sub>OH</sub>	Output HIGH Voltage	I <sub>OH</sub> = -0.1 mA V <sub>CC</sub> = 1.7V to 1.95V	V <sub>CC</sub> - 0.2			V
V <sub>OL</sub>	Output LOW Voltage	I <sub>OL</sub> = 0.1 mA V <sub>CC</sub> = 1.7V to 1.95V			0.2	V
V <sub>IH</sub>	Input HIGH Voltage	V <sub>CC</sub> = 1.7V to 1.95V	0.8 * V <sub>CC</sub>		V <sub>CC</sub> + 0.3V	V
V <sub>IL</sub>	Input LOW Voltage	V <sub>CC</sub> = 1.7V to 1.95V	-0.2		0.2 * V <sub>CC</sub>	V
I <sub>IX</sub>	Input Leakage Current	GND ≤ V <sub>IN</sub> ≤ V <sub>CC</sub>	-1		+1	μA
I <sub>OZ</sub>	Output Leakage Current	GND ≤ V <sub>OUT</sub> ≤ V <sub>CC</sub>	-1		+1	μA
I <sub>CC</sub>	V <sub>CC</sub> Operating Supply Current	f = f <sub>MAX</sub> = 1/t <sub>RC</sub> V <sub>CC</sub> = V <sub>CCmax</sub> I <sub>OUT</sub> = 0 mA CMOS levels		18	20	mA
		f = 1 MHz		3	5	mA
I <sub>SB1</sub>	Automatic CE Power-Down Current — CMOS Inputs	$\overline{CE}_1 \geq V_{CC} - 0.2V, CE_2 \leq 0.2V, V_{IN} > V_{CC} - 0.2V, V_{IN} < 0.2V$ f = f <sub>MAX</sub> (Address and Data Only), f = 0 (OE, WE, BHE and BLE), V <sub>CC</sub> = 3.60V		55	70	μA
I <sub>SB2</sub>	Automatic CE Power-Down Current — CMOS Inputs	$\overline{CE}_1 \geq V_{CC} - 0.2V, CE_2 \leq 0.2V$ V <sub>IN</sub> ≥ V <sub>CC</sub> - 0.2V or V <sub>IN</sub> ≤ 0.2V, f = 0, V <sub>CC</sub> = V <sub>CCMAX</sub>		55	70	μA

**Capacitance**<sup>[8]</sup>

Parameter	Description	Test Conditions	Max.	Unit
C <sub>IN</sub>	Input Capacitance	T <sub>A</sub> = 25°C, f = 1 MHz, V <sub>CC</sub> = V <sub>CC(typ)</sub>	8	pF
C <sub>OUT</sub>	Output Capacitance		8	pF

**Thermal Resistance**<sup>[8]</sup>

Parameter	Description	Test Conditions	VFBGA	Unit
θ <sub>JA</sub>	Thermal Resistance (Junction to Ambient)	Test conditions follow standard test methods and procedures for measuring thermal impedance, per EIA/JESD51.	56	°C/W
θ <sub>JC</sub>	Thermal Resistance (Junction to Case)		11	°C/W

**Notes:**

- V<sub>IL(MIN)</sub> = -0.5V for pulse durations less than 20 ns.
- V<sub>IH(MAX)</sub> = V<sub>CC</sub> + 0.5V for pulse durations less than 20 ns.
- Overshoot and undershoot specifications are characterized and are not 100% tested.
- Tested initially and after any design or process changes that may affect these parameters.

**AC Test Loads and Waveforms**

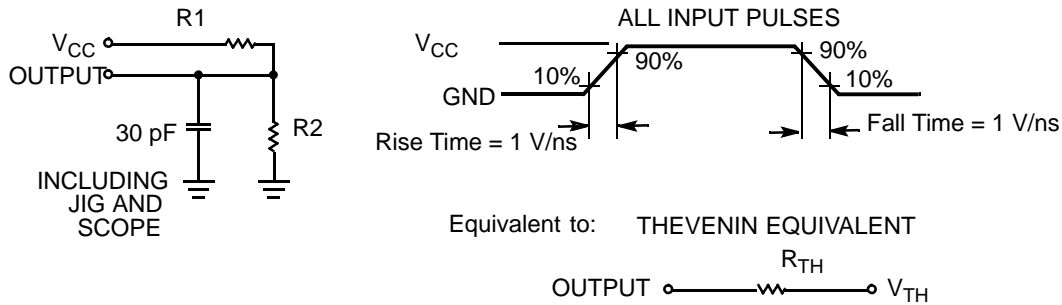

Parameters	1.8V (V <sub>CC</sub> )	Unit
R1	14000	Ω
R2	14000	Ω
R <sub>TH</sub>	7000	Ω
V <sub>TH</sub>	0.90	V

**Switching Characteristics** Over the Operating Range<sup>[9, 10, 11, 15, 14]</sup>

Parameter	Description	70 ns		Unit
		Min.	Max.	
<b>Read Cycle</b>				
t <sub>RC</sub> <sup>[13]</sup>	Read Cycle Time	70	40000	ns
t <sub>CD</sub>	Chip Deselect Time $\overline{CE}_1 = \text{HIGH}$ or $CE_2 = \text{LOW}$ , BLE/BHE High Pulse Time	15		ns
t <sub>AA</sub>	Address to Data Valid		70	ns
t <sub>OHA</sub>	Data Hold from Address Change	10		ns
t <sub>ACE</sub>	$\overline{CE}_1$ LOW and $CE_2$ HIGH to Data Valid		70	ns
t <sub>DOE</sub>	$\overline{OE}$ LOW to Data Valid		35	ns
t <sub>LZOE</sub>	$\overline{OE}$ LOW to Low Z <sup>[10, 11, 12]</sup>	5		ns
t <sub>HZOE</sub>	$\overline{OE}$ HIGH to High Z <sup>[10, 11, 12]</sup>		25	ns
t <sub>LZCE</sub>	$\overline{CE}_1$ LOW and $CE_2$ HIGH to Low Z <sup>[10, 11, 12]</sup>	10		ns
t <sub>HZCE</sub>	$\overline{CE}_1$ HIGH and $CE_2$ LOW to High Z <sup>[10, 11, 12]</sup>		25	ns
t <sub>DBE</sub>	$\overline{BLE/BHE}$ LOW to Data Valid		70	ns
t <sub>LZBE</sub>	$\overline{BLE/BHE}$ LOW to Low Z <sup>[10, 11, 12]</sup>	5		ns
t <sub>HZBE</sub>	$\overline{BLE/BHE}$ HIGH to High Z <sup>[10, 11, 12]</sup>		25	ns

**Notes:**

- Test conditions for all parameters other than tri-state parameters assume signal transition time of 1 ns/V, timing reference levels of V<sub>CC(typ.)</sub>/2, input pulse levels of 0V to V<sub>CC</sub>, and output loading of the specified I<sub>OL</sub>/I<sub>OH</sub> as shown in the "AC Test Loads and Waveforms" section.
- At any given temperature and voltage conditions t<sub>HZCE</sub> is less than t<sub>LZCE</sub>, t<sub>HZBE</sub> is less than t<sub>LZBE</sub>, t<sub>HZOE</sub> is less than t<sub>LZOE</sub>, and t<sub>HZWE</sub> is less than t<sub>LZWE</sub> for any given device. All low-Z parameters will be measured with a load capacitance of 30 pF (3V).
- t<sub>HZOE</sub>, t<sub>HZCE</sub>, t<sub>HZBE</sub>, and t<sub>HZWE</sub> transitions are measured when the outputs enter a high-impedance state.
- High-Z and Low-Z parameters are characterized and are not 100% tested.
- If invalid address signals shorter than min.t<sub>RC</sub> are continuously repeated for 40 μs, the device needs a normal read timing (t<sub>RC</sub>) or needs to enter standby state at least once in every 40 μs.
- In order to achieve 70-ns performance, the read access must be Chip Enable ( $\overline{CE}_1$  or  $CE_2$ ) controlled. That is, the addresses must be stable prior to Chip Enable going active.

**Switching Characteristics** Over the Operating Range<sup>[9, 10, 11, 15, 14]</sup> (continued)

Parameter	Description	70 ns		Unit
		Min.	Max.	
<b>Write Cycle<sup>[15]</sup></b>				
$t_{WC}$	Write Cycle Time	70	40000	ns
$t_{SCE}$	$\overline{CE}_1$ LOW and $CE_2$ HIGH to Write End	60		ns
$t_{AW}$	Address Set-Up to Write End	60		ns
$t_{CD}$	Chip Deselect Time $\overline{CE}_1 = \text{HIGH}$ or $CE_2 = \text{LOW}$ , BLE/BHE High Pulse Time	15		ns
$t_{HA}$	Address Hold from Write End	0		ns
$t_{SA}$	Address Set-Up to Write Start	0		ns
$t_{PWE}$	$\overline{WE}$ Pulse Width	50		ns
$t_{BW}$	BLE/BHE LOW to Write End	60		ns
$t_{SD}$	Data Set-Up to Write End	25		ns
$t_{HD}$	Data Hold from Write End	0		ns
$t_{HZWE}$	$\overline{WE}$ LOW to High-Z <sup>[10, 11, 12]</sup>		25	ns
$t_{LZWE}$	$\overline{WE}$ HIGH to Low-Z <sup>[10, 11, 12]</sup>	10		ns

**Note:**

15. The internal Write time of the memory is defined by the overlap of  $\overline{WE}, \overline{CE}_1 = V_{IL}$  or  $CE_2 = V_{IH}, \overline{BHE}$  and/or  $\overline{BLE} = V_{IL}$ . All signals must be ACTIVE to initiate a write and any of these signals can terminate a write by going INACTIVE. The data input set-up and hold timing should be referenced to the edge of the signal that terminates the write.

**Switching Waveforms**

**Read Cycle 1 (Address Transition Controlled)<sup>[17, 18]</sup>**

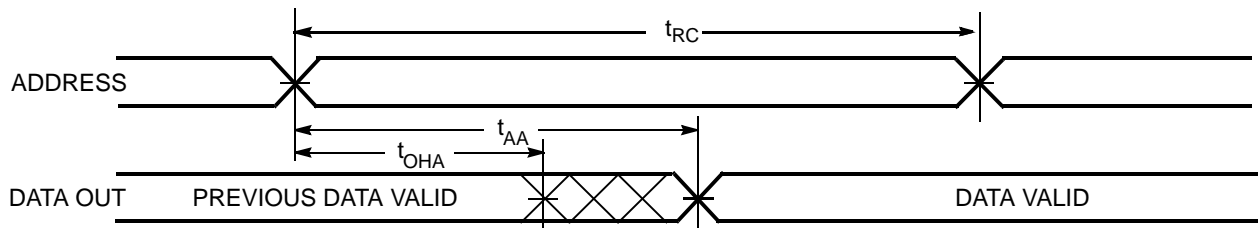

**Read Cycle 2 ( $\overline{OE}$  Controlled)<sup>[16, 18, 19]</sup>**

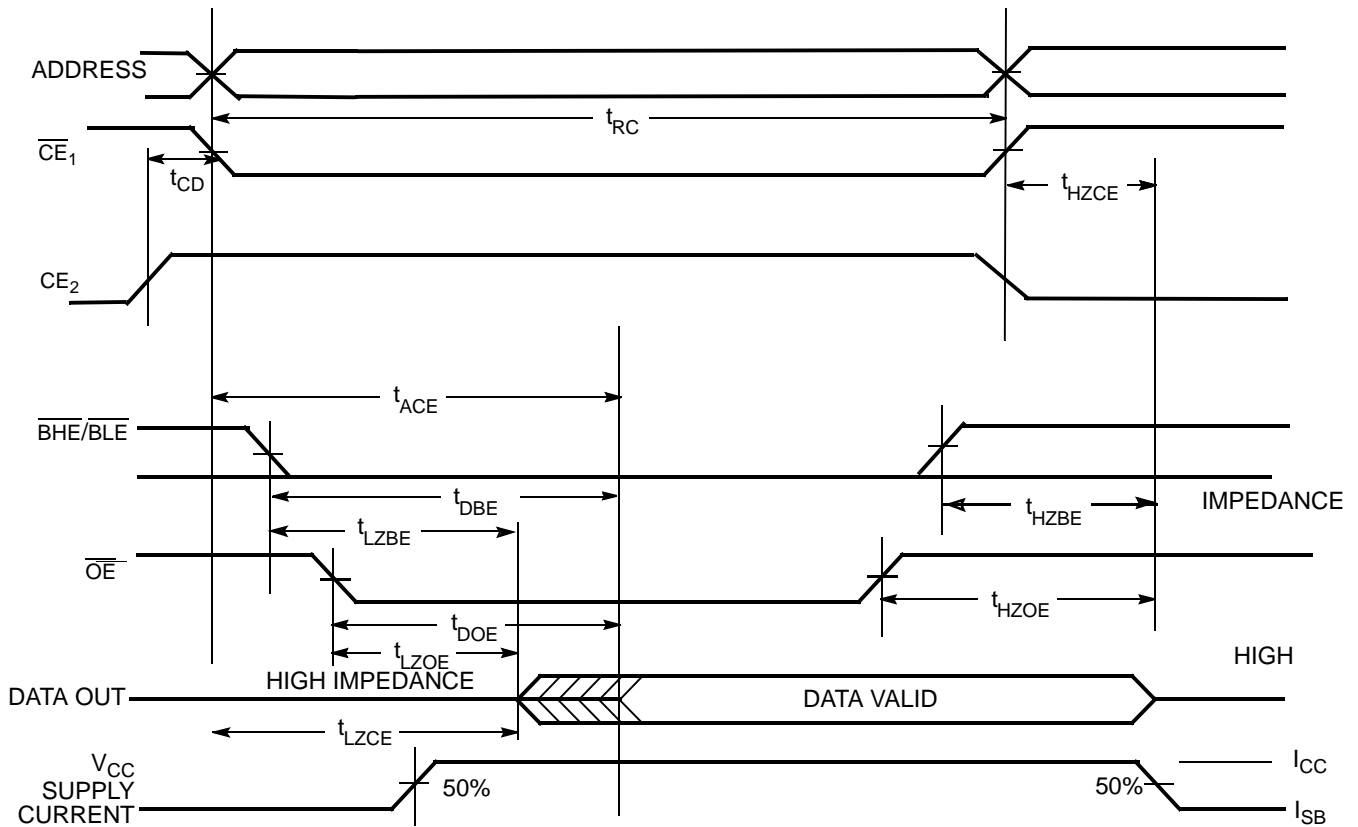

**Notes:**

- 16. Whenever  $\overline{CE}_1 = \text{HIGH}$  or  $\overline{CE}_2 = \text{LOW}$ ,  $\overline{BHE}/\overline{BLE}$  are taken inactive, they must remain inactive for a minimum of 5 ns.
- 17. Device is continuously selected.  $\overline{OE} = \overline{CE}_1 = V_{IL}$  and  $\overline{CE}_2 = V_{IH}$ .
- 18.  $\overline{WE}$  is HIGH for Read Cycle.
- 19.  $\overline{CE}$  is the Logical AND of  $\overline{CE}_1$  and  $\overline{CE}_2$ .

**Switching Waveforms** (continued)

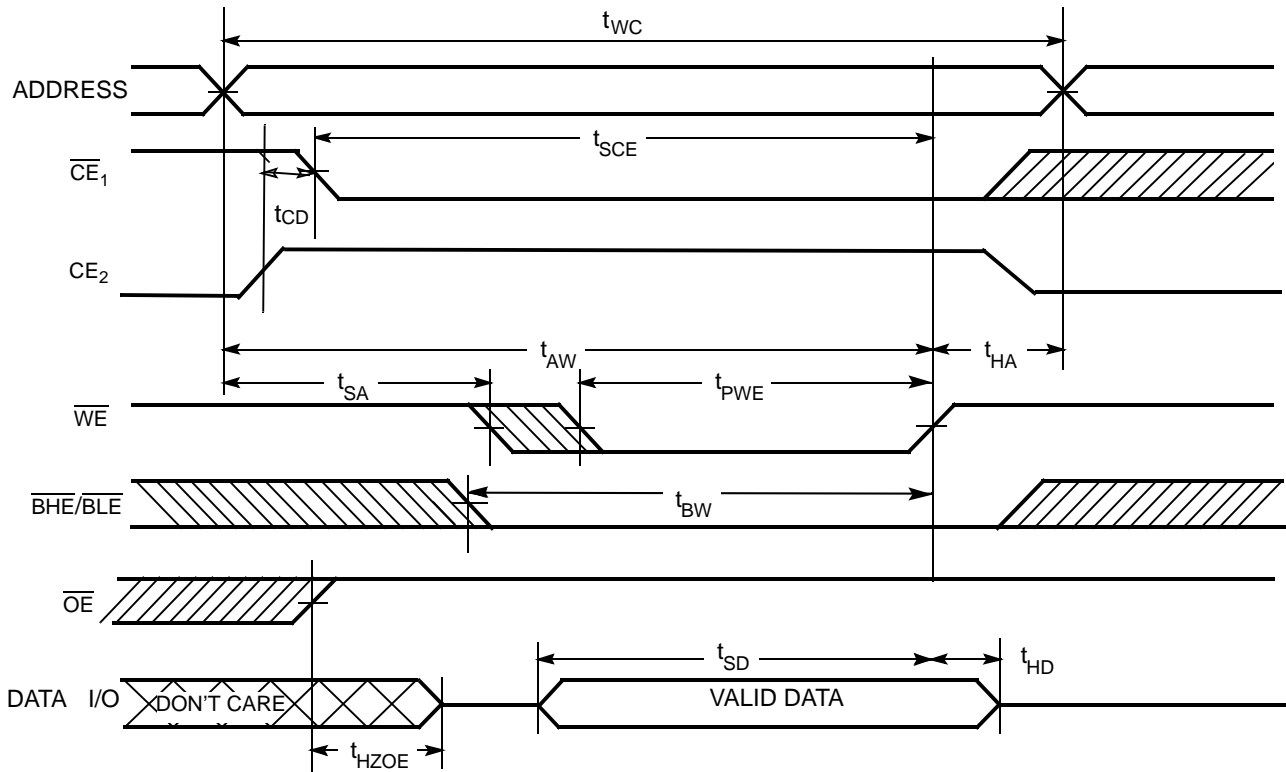

**Notes:**

- 20. Data I/O is high-impedance if  $\overline{OE} \geq V_{IH}$ .
- 21. During the DON'T CARE period in the DATA I/O waveform, the I/Os are in output state and input signals should not be applied.

Switching Waveforms (continued)

Write Cycle 2 ( $\overline{CE}_1$  or  $\overline{CE}_2$  Controlled)<sup>[15, 12, 16, 20, 21]</sup>

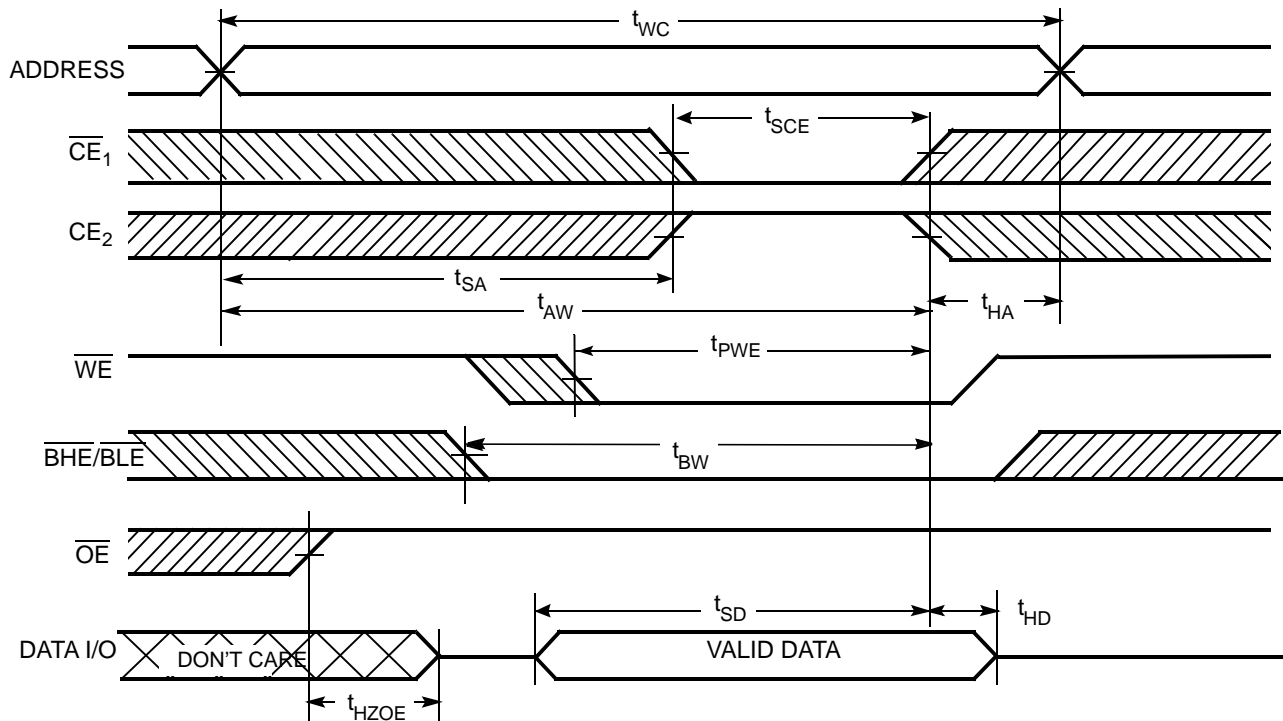

Write Cycle 3 ( $\overline{WE}$  Controlled,  $\overline{OE}$  LOW)<sup>[16, 21]</sup>

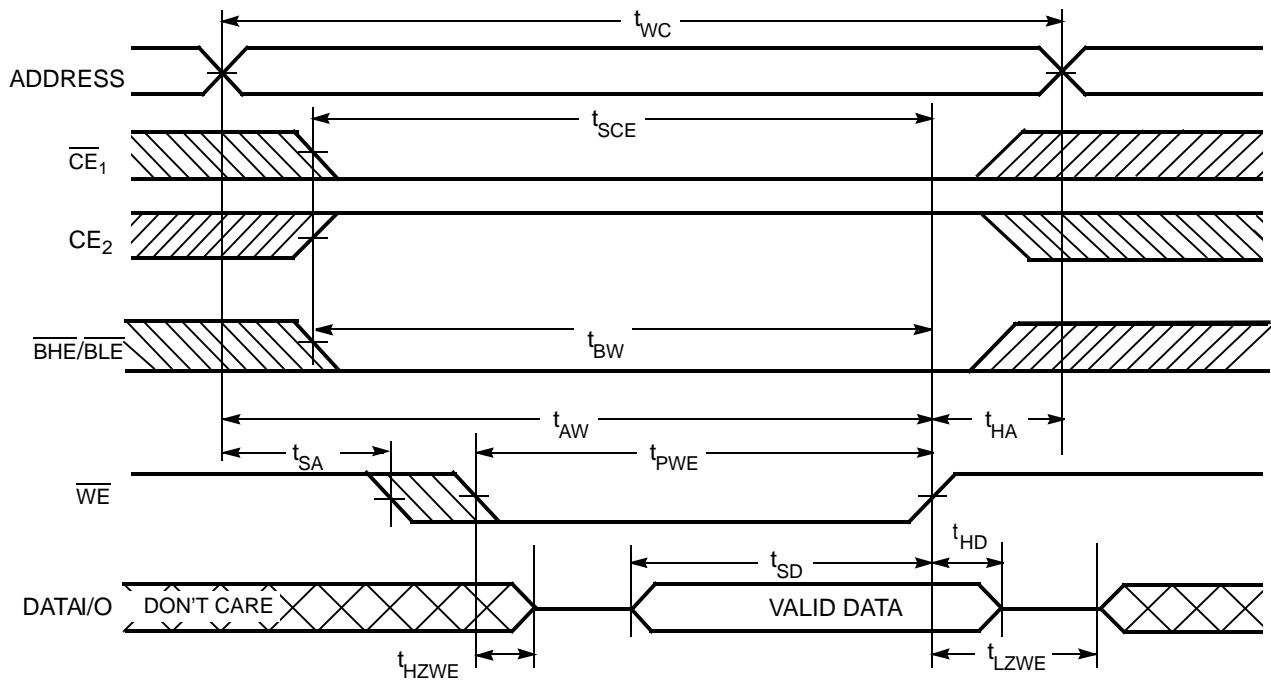



**Switching Waveforms** (continued)

**Write Cycle 4 (BHE/BLE Controlled, OE LOW)**<sup>[15, 16, 20, 21]</sup>

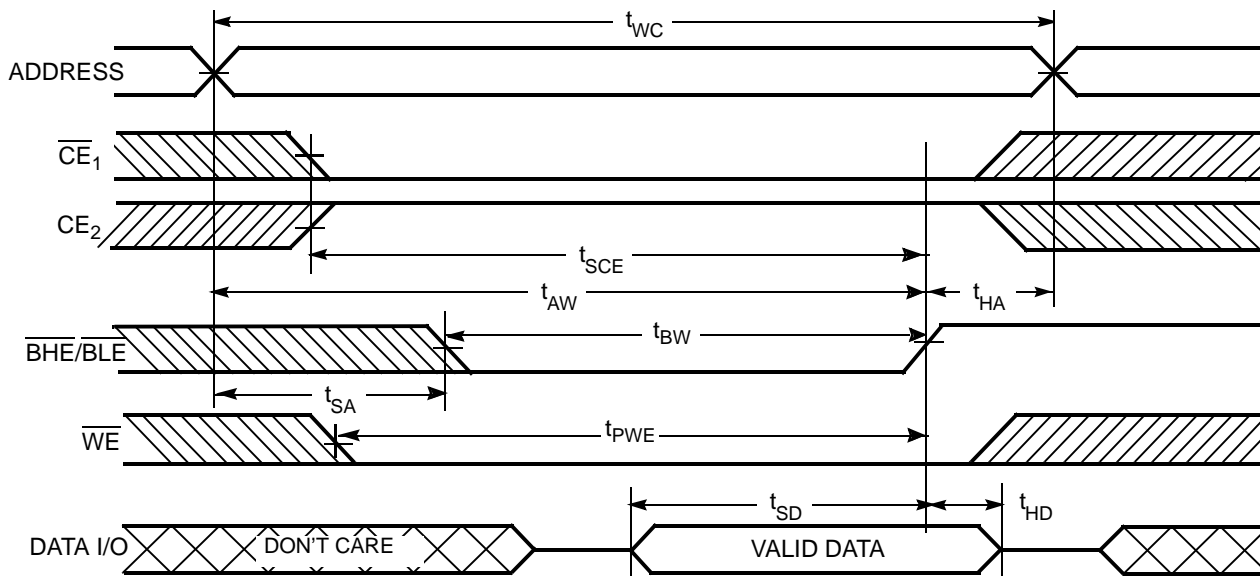

**Truth Table**<sup>[22]</sup>

$\overline{CE}_1$	$\overline{CE}_2$	$\overline{WE}$	$\overline{OE}$	$\overline{BHE}$	$\overline{BLE}$	Inputs/Outputs	Mode	Power
H	X	X	X	X	X	High Z	Deselect/Power-down	Standby ( $I_{SB}$ )
X	L	X	X	X	X	High Z	Deselect/Power-down	Standby ( $I_{SB}$ )
X	X	X	X	H	H	High Z	Deselect/Power-down	Standby ( $I_{SB}$ )
L	H	H	L	L	L	Data Out (I/O <sub>0</sub> –I/O <sub>15</sub> )	Read	Active ( $I_{CC}$ )
L	H	H	L	H	L	Data Out (I/O <sub>0</sub> –I/O <sub>7</sub> ); I/O <sub>8</sub> –I/O <sub>15</sub> in High Z	Read	Active ( $I_{CC}$ )
L	H	H	L	L	H	Data Out (I/O <sub>8</sub> –I/O <sub>15</sub> ); I/O <sub>0</sub> –I/O <sub>7</sub> in High Z	Read	Active ( $I_{CC}$ )
L	H	H	H	L	L	High Z	Output Disabled	Active ( $I_{CC}$ )
L	H	H	H	H	L	High Z	Output Disabled	Active ( $I_{CC}$ )
L	H	H	H	L	H	High Z	Output Disabled	Active ( $I_{CC}$ )
L	H	L	X	L	L	Data In (I/O <sub>0</sub> –I/O <sub>15</sub> )	Write (Upper Byte and Lower Byte)	Active ( $I_{CC}$ )
L	H	L	X	H	L	Data In (I/O <sub>0</sub> –I/O <sub>7</sub> ); I/O <sub>8</sub> –I/O <sub>15</sub> in High Z	Write (Lower Byte Only)	Active ( $I_{CC}$ )
L	H	L	X	L	H	Data In (I/O <sub>8</sub> –I/O <sub>15</sub> ); I/O <sub>0</sub> –I/O <sub>7</sub> in High Z	Write (Upper Byte Only)	Active ( $I_{CC}$ )

**Note:**  
22. H = Logic HIGH, L = Logic LOW, X = Don't Care.

### Ordering Information

Speed (ns)	Ordering Code	Package Diagram	Package Type	Operating Range
70	CYU01M16SFEU-70BVXI	51-85150	48-ball Fine Pitch VBGA (6 mm x 8 mm x 1 mm) (Pb-Free)	Industrial

### Package Diagram

#### 48-ball VFBGA (6 x 8 x 1 mm) (51-85150)

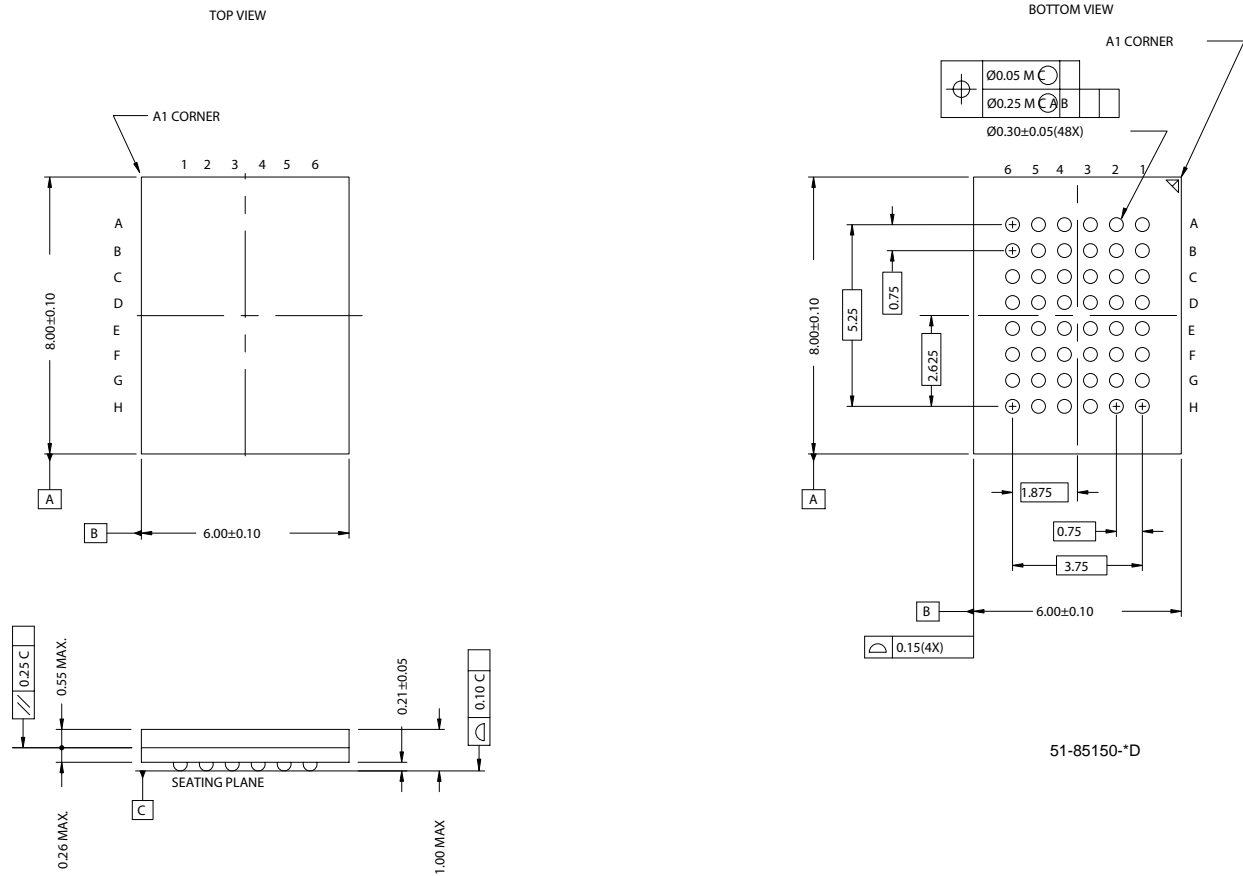

MoBL is a registered trademark and MoBL3 and More Battery Life are trademarks of Cypress Semiconductor Corporation. All product and company names mentioned in this document may be the trademarks of their respective holders.

**Document History Page**

Document Title: CYU01M16SFE MoBL3™ 16-Mbit (1M x 16) Pseudo Static RAM				
Document Number: 38-05603				
REV.	ECN NO.	Issue Date	Orig. of Change	Description of Change
**	342199	See ECN	PCI	New Data sheet
*A	386551	See ECN	PCI	Changed from Advance to Preliminary Replaced TBDs with appropriate values Changed $t_{PC}$ and $t_{PA}$ from 20 to 25 ns Corrected footnote # 16 as $\overline{OE} = \overline{CE}_1 = V_{IL}$ and $CE_2 = V_{IH}$ Added separate waveforms for $\overline{CE}_1$ and $CE_2$ in Read #2, Page Read and Write#1 Timing diagram
*B	422623	See ECN	HRT	Removed the 55-ns Speed Bin Changed Isb2 Max value from 60 $\mu A$ to 70 $\mu A$ Added Isb1 to the DC parameters Added Chip Enable Access Foot Note to AC Parameters Changed the $t_{CD}$ Min value from 5 ns to 15 ns Changed the Page Mode Values ( $t_{PC}$ and $t_{PAA}$ ) from 25 ns to 35 ns
*C	462289	See ECN	NXR	Revised MPN from CYU01M16SFCU to CYU01M16SFE Renamed Package Name column with Package Diagram
*D	492939	See ECN	NXR	Removed Page Mode feature
*E	504021	See ECN	NXR	Converted from Preliminary to Final Changed $I_{CC}(\text{Max})$ from 25 mA to 20 mA Changed $t_{OHA}(\text{Min})$ from 5 ns to 10 ns