

DATA SHEET

CHIP RESISTORS ARRAY

YC324 (8Pin/4R)

5%; 1%

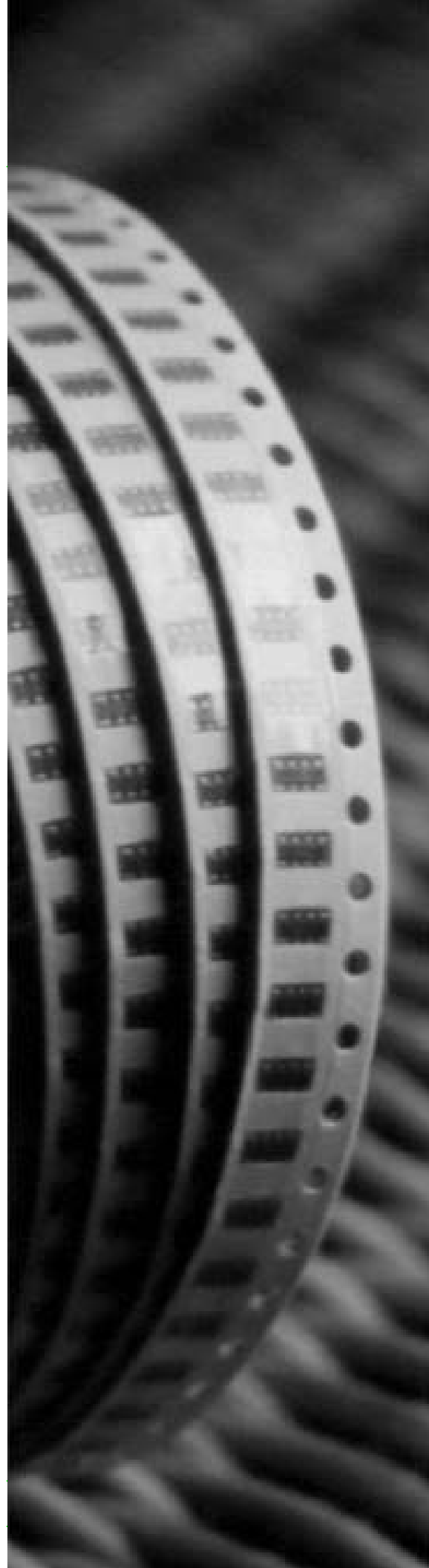

SCOPE

This specification describes YC324 series chip resistors made by thick film process.

ORDERING INFORMATION

Part number is identified by the series, size, tolerance, packing style, temperature coefficient, special type and resistance value.

YC324 - X X X XX XXXX
(1) (2) (3) (4) (5)

(1) TOLERANCE

- F = ±1%
- J = ±5%

(2) PACKAGING TYPE

K = Embossed tapping reel

(3) TEMPERATURE CHARACTERISTIC OF RESISTANCE

- G = ±200ppm/°C
- = Base on spec

(4) SPECIAL TYPE

07 = 7 inch dia. Reel

(5) RESISTANCE VALUE:

56R, 560R, 5K6, 56K, 1M.

MARKING

YC324



Fig. 1 5% Marking, Value=56Ω

First two digits for significant figure and 3rd digit for number of zeros

Letter R: decimal place

DIMENSION

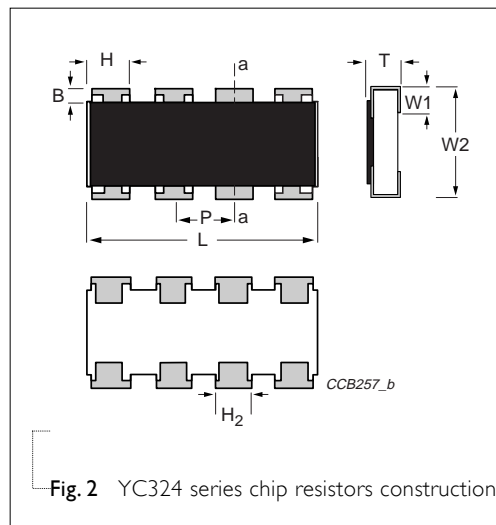
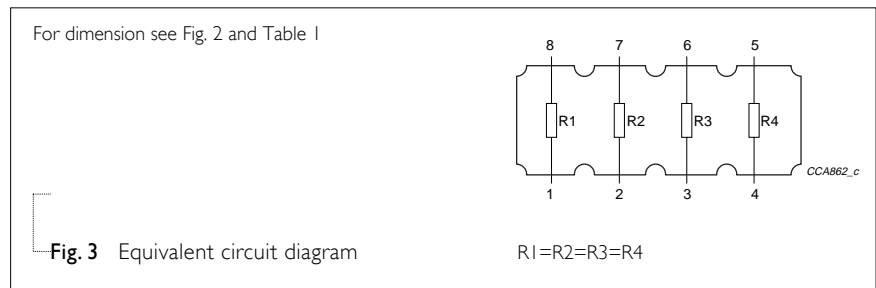

Fig. 2 YC324 series chip resistors construction

Table I

TYPE	YC324
B (mm)	0.5±0.2
H (mm)	1.1±0.15
P (mm)	1.27±0.05
L (mm)	5.08±0.2
H ₂ (mm)	0.9±0.15
T (mm)	0.6±0.1
W ₁ (mm)	0.5±0.15
W ₂ (mm)	3.2±0.2

SCHEMATIC



POWER RATING

**RATED POWER AT 70°C,
YC324=1/8W FOR ELEMENT**

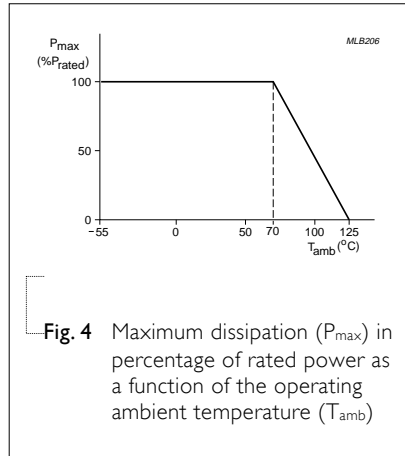

Fig. 4 Maximum dissipation (P_{max}) in percentage of rated power as a function of the operating ambient temperature (T_{amb})

RATED VOLTAGE:

The DC or AC (rms) continuous working voltage corresponding to the rated power is determined by the following formula:

$$V = \sqrt{P \times R}$$

Where

V=Continuous rated DC or AC (rms) working voltage (V)

P=Rated power (W)

R=Resistance value (Ω)

ELECTRICAL CHARACTERISTICS

Table 2

CHARACTERISTICS	YC324 1/8W
Operating Temperature Range	-55°C to +125°C
Maximum Working Voltage	200V
Maximum Overload Voltage	400V
Dielectric Withstanding Voltage	500V
Number of Resistors	4
Resistance Range	10Ω to 1MΩ
Temperature Coefficient	±200ppm/°C

TAPING REEL

Table 3

DIMENSION	YC324
Tape Width	12
ØA (mm)	180+0/-3
ØB (mm)	60+1/-0
ØC (mm)	13.0±0.2
ØD (mm)	21±0.8
W (mm)	13.0±0.3
T (mm)	15.4±1

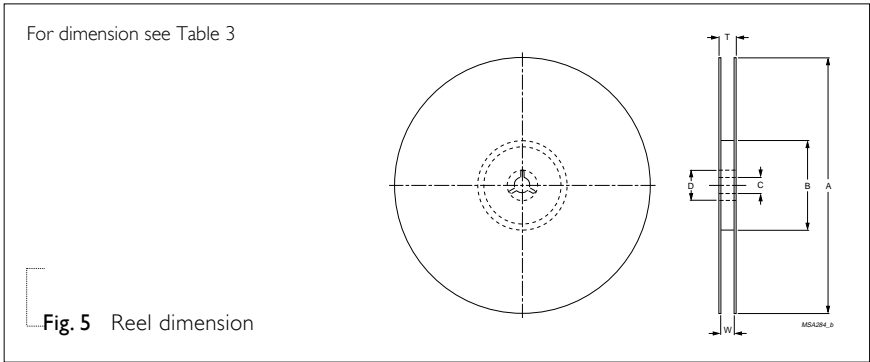

EMBOSSED TAPE SPECIFICATION

Table 4

DIMENSION	YC324
A (mm)	3.5±0.2
B (mm)	5.6±0.2
W (mm)	12±0.3
E (mm)	1.75±0.1
F (mm)	5.5±0.05
P ₀ (mm)	4.0±0.1
P ₁ (mm)	4.0±0.1
P ₂ (mm)	2.0±0.05
ØD ₀ (mm)	1.5+0.1/-0
ØD ₁ (mm)	1.5±0.25
T (mm)	1.0±0.1

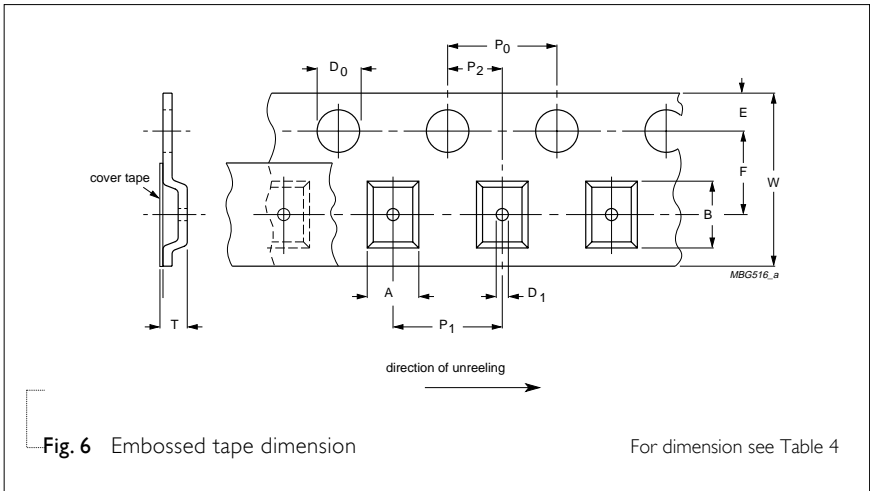

PACKING METHOD

LEADER/TRAILER TAPE SPECIFICATION

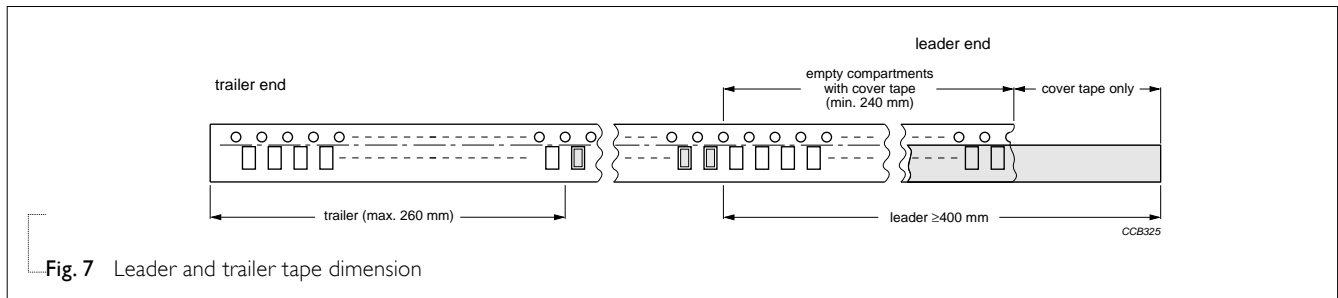

Table 5 Packing style and packaging quantity

PACKING STYLE	REEL DIMENSION	YC324
Embossed Taping Reel (K)	7" (178 mm)	4,000

TYPE	TEST METHOD	ACCEPTANCE STANDARD				
Temperature Coefficient of Resistance (T.C.R.)	<p>Measure resistance at +25°C or specified room temperature as R₁, then measure at -55°C or +125°C respectively as R₂. Determine the temperature coefficient of resistance from the following formula:</p>	<p>Formula</p> <hr/> $T.C.R. = \frac{R_2 - R_1}{R_1(t_2 - t_1)} \times 10^6 \text{ (ppm/}^\circ\text{C)}$ <p>Where t₁=+25°C or specified room temperature t₂=-55°C or +125°C test temperature R₁=resistance at reference temperature in ohms R₂=resistance at test temperature in ohms</p>				
Thermal Shock	<p>At -55±3°C for 2 minutes and at +125±2°C for 2 minutes as one cycle. After 5 cycles, the specimen shall be stabilized at room temp. Measure the resistance to determine ΔR/R (%) after one more hour.</p>	<p>±(1%+0.05Ω) for 5% tolerance ±(0.5%+0.05Ω) for 1% tolerance</p>				
Low Temperature Operation	<p>Place the specimen in a test chamber maintained at -65 (+0/-5)°C. After one hour stabilization at this temperature, full rated working voltage shall be applied for 45 (+5/-0) minutes. Have 15 (+5/-0) minutes after remove the voltage, the specimen shall be removed from the chamber and stabilized at room temperature for 24 hrs. Measure the resistance to determine ΔR/R(%).</p>	<p>±(1.0%+0.05Ω) for 5% tolerance ±(0.5%+0.05Ω) for 1% tolerance No visible damage</p>				
Short Time Overload	<p>Apply 2.5 times of rated voltage but not exceeding the maximum overload voltage for 5 seconds. Have the specimen stabilized at room temperature for 30 minutes minimum. Measure the resistance to determine ΔR/R (%).</p>	<p>±(2.0%+0.05Ω) for 5% tolerance ±(1%+0.05Ω) for 1% tolerance No visible damage</p>				
Insulation Resistance	<p>Place the specimen in the jig and apply a rated continuous overload voltage (R.C.O.V) for one minute as shown. Measure the insulation resistance.</p>	<table border="1"> <tr> <td>Type</td> <td>YC324</td> </tr> <tr> <td>Voltage (DC)</td> <td>400V</td> </tr> </table> <p>≥10,000MΩ</p>	Type	YC324	Voltage (DC)	400V
Type	YC324					
Voltage (DC)	400V					
Dielectric Withstand Voltage	<p>Place the specimen in the jig and apply a specified value continuous overload voltage as shown for one minute.</p>	<table border="1"> <tr> <td>Type</td> <td>YC324</td> </tr> <tr> <td>Voltage (AC)</td> <td>500Vrms</td> </tr> </table> <p>Breakdown voltage> specification and without open/short</p>	Type	YC324	Voltage (AC)	500Vrms
Type	YC324					
Voltage (AC)	500Vrms					
Resistance To Soldering Heat	<p>Immerse the specimen in the solder pot at 260±5°C. for 10±1 seconds. Have the specimen stabilized at room temperature for 30 minutes minimum. Measure the resistance to determine ΔR/R (%).</p>	<p>±(1.0%+0.05Ω) for 5% tolerance ±(0.5%+0.05Ω) for 1% tolerance No visible damage</p>				

TYPE	TEST METHOD	ACCEPTANCE STANDARD
Moisture Resistance	Place the specimen in the test chamber and subject to 42 damp heat cycles. Each one of which consists of the steps 1 to 7 as figure 9. The total length of test is 1,000 hours. Have the specimen stabilized at room temperature for 24 hours after testing. Measure the resistance to determine $\Delta R/R$ (%).	$\pm(2.0\%+0.05\Omega)$ for 5% tolerance $\pm(0.5\%+0.05\Omega)$ for 1% tolerance No visible damage
Life	Place the specimen in the oven at $70\pm 2^\circ\text{C}$. Apply the rated voltage to the specimen at the 1.5 hours on and 0.5 hour off cycle. The total length of test is 1,000 hours. Have the specimen stabilized at room temperature for one hour minimum after testing. Measure the $\Delta R/R$ (%).	$\pm(3\%+0.05\Omega)$ for 5% tolerance $\pm(1\%+0.05\Omega)$ for 1% tolerance No visible damage
Solderability	Immerse the specimen in the solder pot at $235\pm 5^\circ\text{C}$ for 5 sec.	At least 95% solder coverage on the termination
Bending Strength	Mount the specimen on a test board as shown in the figure 8. Slowly apply the force till the board is bent for 5 ± 1 sec. Measure the $\Delta R/R$ (%) at this position.	$\pm(1.0\%+0.05\Omega)$ for 5% tolerance No visible damage

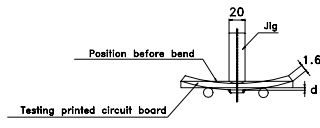

Fig. 8 Principle of the bending test

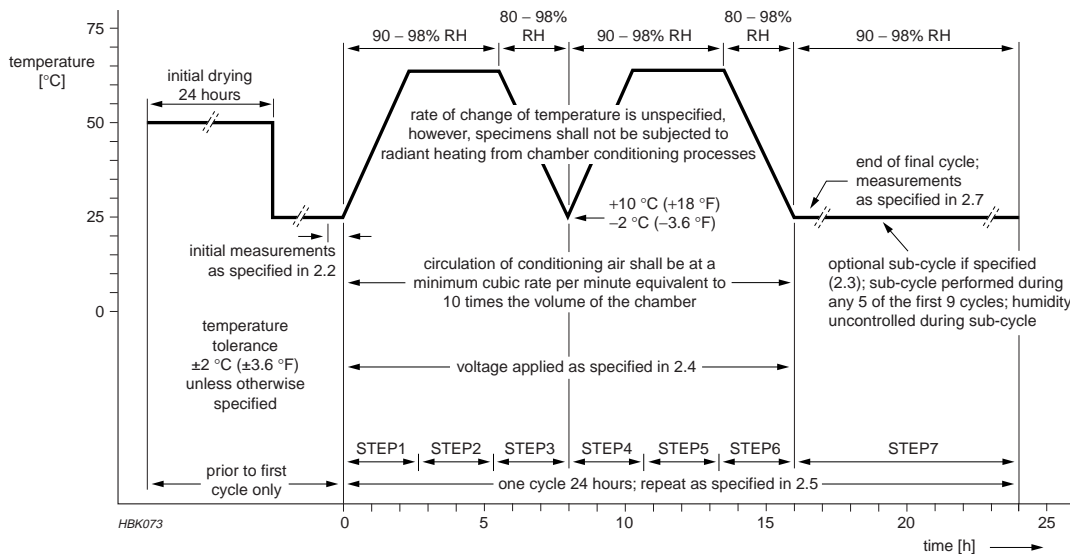

Fig. 9 Conditions by change of temperature