

# FLASH MEMORY

CMOS

**64 M (8 M × 8/4 M × 16) BIT**

Dual Operation

## MBM29DL64DF-70

### DESCRIPTION

MBM29DL64DF is a 64 M-bit, 3.0 V-only Flash memory organized as 8 Mbytes of 8 bits each or 4 M words of 16 bits each. The device comes in 48-pin TSOP (1) and 48-ball FBGA packages. This device is designed to be programmed in system with 3.0 V  $V_{CC}$  supply. 12.0 V  $V_{PP}$  and 5.0 V  $V_{CC}$  are not required for write or erase operations. The device can also be reprogrammed in standard EPROM programmers.

The device is organized into four physical banks : Bank A, Bank B, Bank C and Bank D, which are considered to be four separate memory arrays operations. This device is the almost identical to Fujitsu's standard 3 V only Flash memories, with the additional capability of allowing a normal non-delayed read access from a non-busy bank of the array while an embedded write (either a program or an erase) operation is simultaneously taking place on the other bank.

*(Continued)*

### PRODUCT LINE UP

Part No.	MBM29DL64DF-70
Power Supply Voltage $V_{CC}$ (V)	3.0 V $^{+0.6V}_{-0.3V}$
Max Address Access Time (ns)	70
Max $\overline{CE}$ Access Time (ns)	70
Max $\overline{OE}$ Access Time (ns)	30

### PACKAGES

48-pin plastic TSOP (1)

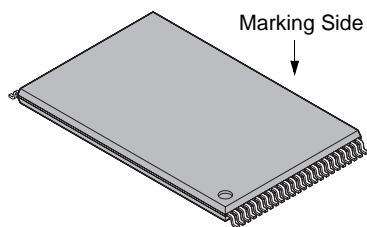

(FPT-48P-M19)

48-ball plastic FBGA

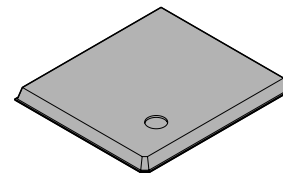

(BGA-48P-M13)

# MBM29DL64DF-70

(Continued)

The new design concept called FlexBank™\*1 Architecture is implemented. With this concept the device can execute simultaneous operation between Bank 1, a bank chosen from among the four banks, and Bank 2, a bank consisting of the three remaining banks. This means that any bank can be chosen as Bank 1. (Refer to ■FUNCTIONAL DESCRIPTION for Simultaneous Operation.)

The standard device offers access times 70 ns, allowing operation of high-speed microprocessors without the wait. To eliminate bus contention the device has separate chip enable ( $\overline{CE}$ ), write enable ( $\overline{WE}$ ) and output enable ( $\overline{OE}$ ) controls.

This device supports pin and command set compatible with JEDEC standard E<sup>2</sup>PROMs. Commands are written to the command register using standard microprocessor write timings. Register contents serve as input to an internal state-machine which controls the erase and programming circuitry. Write cycles also internally latch addresses and data needed for the programming and erase operations. Reading data out of the device is similar to reading from 5.0 V and 12.0 V Flash or EPROM devices.

The device is programmed by executing the program command sequence. This invokes the Embedded Program Algorithm™ which is an internal algorithm that automatically times the program pulse widths and verifies proper cell margin. Typically each sector can be programmed and verified in about 0.5 seconds. Erase is accomplished by executing the erase command sequence. This invokes the Embedded Erase Algorithm™ which is an internal algorithm that automatically preprograms the array if it is not already programmed before executing the erase operation. During erase, the device automatically times the erase pulse widths and verifies the proper cell margin.

Each sector is typically erased and verified in 0.5 second (if already completely preprogrammed).

The device also features sector erase architecture. The sector mode allows each sector to be erased and reprogrammed without affecting other sectors. The device is erased when shipped from the factory.

The device features single 3.0 V power supply operation for both read and write functions. Internally generated and regulated voltages are provided for the program and erase operations. A low  $V_{CC}$  detector automatically inhibits write operations on the loss of power. The end of program or erase is detected by  $\overline{Data}$  Polling of  $DQ_7$ , by the Toggle Bit feature on  $DQ_6$ , or the  $RY/\overline{BY}$  output pin. Once the end of a program or erase cycle is completed, the device internally returns to the read mode.

The device also has a hardware  $\overline{RESET}$  pin. When this pin is driven low, execution of any Embedded Program Algorithm or Embedded Erase Algorithm is terminated. The internal state machine is then reset to the read mode. The  $\overline{RESET}$  pin may be tied to the system reset circuitry. Therefore if a system reset occurs during the Embedded Program™\*2 Algorithm or Embedded Erase™\*2 Algorithm, the device is automatically reset to the read mode and have erroneous data stored in the address locations being programmed or erased. These locations need rewriting after the reset. Resetting the device enables the system's microprocessor to read the boot-up firmware from the Flash memory.

Fujitsu Flash technology combines years of Flash memory manufacturing experience to produce the highest levels of quality, reliability, and cost effectiveness. The device memory electrically erases the entire chip or all bits within a sector simultaneously via Fowler-Nordhiem tunneling. The bytes/words are programmed one byte/word at a time using the EPROM programming mechanism of hot electron injection.

\*1 : FlexBank™ is a trademark of Fujitsu Limited.

\*2 : Embedded Erase™ and Embedded Program™ are trademarks of Advanced Micro Devices, Inc.

## ■ FEATURES

- **0.17  $\mu\text{m}$  Process Technology**
- **Two-bank Architecture for Simultaneous Read/Program and Read/Erase**
- **FlexBank™ \*1**
  - Bank A : 8 Mbit (8 KB  $\times$  8 and 64 KB  $\times$  15)
  - Bank B : 24 Mbit (64 KB  $\times$  48)
  - Bank C : 24 Mbit (64 KB  $\times$  48)
  - Bank D : 8 Mbit (8 KB  $\times$  8 and 64 KB  $\times$  15)Two virtual Banks are chosen from the combination of four physical banks (Refer to “■FUNCTIONAL DESCRIPTION FlexBank™ Architecture” and “Example of Virtual Banks Combination”).  
Host system can program or erase in one bank, and then read immediately and simultaneously from the other bank with zero latency between read and write operations.  
Read-while-erase  
Read-while-program
- **Single 3.0 V Read, Program, and Erase**
  - Minimized system level power requirements
- **Compatible with JEDEC-standard Commands**
  - Uses the same software commands as E<sup>2</sup>PROMs
- **Compatible with JEDEC-standard Worldwide Pinouts**
  - 48-pin TSOP (1) (Package suffix : TN – Normal Bend Type)
  - 48-ball FBGA (Package suffix : PBT)
- **Minimum 100,000 Program/Erase Cycles**
- **High Performance**
  - 70 ns maximum access time
- **Sector Erase Architecture**
  - Sixteen 4 Kword and one hundred twenty-six 32 Kword sectors in word mode
  - Sixteen 8 Kbyte and one hundred twenty-six 64 Kbyte sectors in byte mode
  - Any combination of sectors can be concurrently erased. Also supports full chip erase.
- **HiddenROM Region**
  - 256 byte of HiddenROM, accessible through a new “HiddenROM Enable” command sequence
  - Factory serialized and protected to provide a secure electronic serial number (ESN)
- **$\overline{\text{WP}}/\text{ACC}$  Input Pin**
  - At  $V_{\text{IL}}$  allows protection of “outermost” 2  $\times$  8 Kbytes on both ends of boot sectors, regardless of sector group protection/unprotection status
  - At  $V_{\text{ACC}}$ , increases program performance
- **Embedded Erase™ \*2 Algorithms**
  - Automatically preprograms and erases the chip or any sector
- **Embedded Program™ \*2 Algorithms**
  - Automatically programs and verifies data at specified address

\*1 : FlexBank™ is a trademark of Fujitsu Limited

\*2 : Embedded Erase™ and Embedded Program™ are trademarks of Advanced Micro Devices, Inc.

(Continued)

# MBM29DL64DF-70

(Continued)

- **$\overline{\text{Data Polling and Toggle Bit}}$  feature for program detection or erase cycle completion**
- **Ready/Busy Output (RY/BY)**  
Hardware method for detection of program or erase cycle completion
- **Automatic Sleep Mode**  
When addresses remain stable, the device automatically switches itself to low power mode.
- **Low  $V_{cc}$  Write Inhibit  $\leq 2.5$  V**
- **Program Suspend/Resume**  
Suspends the program operation to allow a read in another byte
- **Erase Suspend/Resume**  
Suspends the erase operation to allow a read data and/or program in another sector within the same device
- **Sector Group Protection**  
Hardware method disables any combination of sector groups from program or erase operations
- **Sector Group Protection Set function by Extended sector group protection command**
- **Fast Programming Function by Extended Command**
- **Temporary Sector Group Unprotection**  
Temporary sector group unprotection via the  $\overline{\text{RESET}}$  pin.
- **In accordance with CFI (Common Flash Memory Interface)**

## ■ PIN ASSIGNMENTS

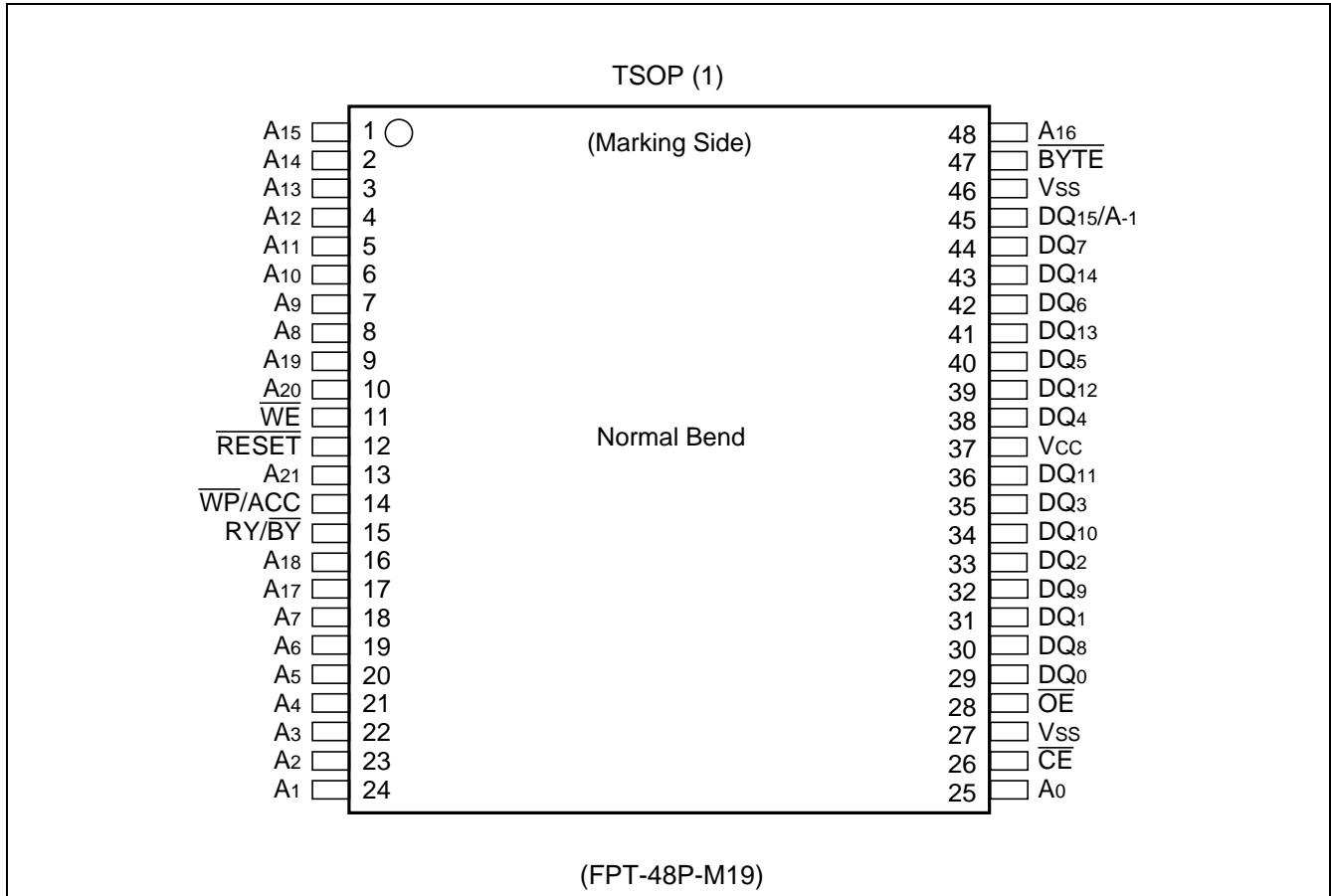

(Continued)

# MBM29DL64DF-70

(Continued)

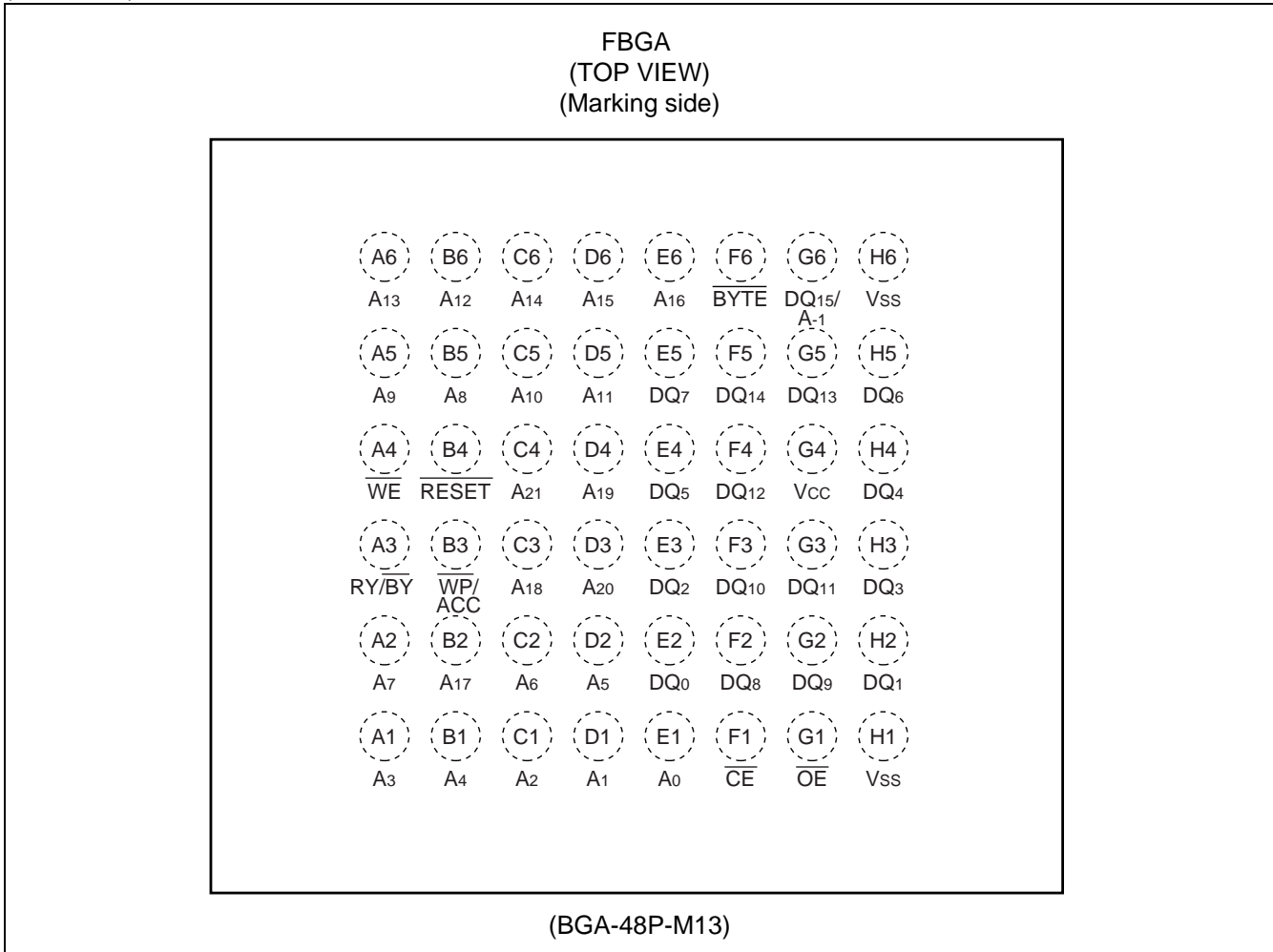

## ■ PIN DESCRIPTIONS

Pin	Function
A <sub>21</sub> to A <sub>0</sub> , A <sub>-1</sub>	Address Input
DQ <sub>15</sub> to DQ <sub>0</sub>	Data Input/Output
$\overline{\text{CE}}$	Chip Enable
$\overline{\text{OE}}$	Output Enable
$\overline{\text{WE}}$	Write Enable
RESET	Hardware Reset Pin/Temporary Sector Group Unprotection
RY/BY	Ready/Busy Output
BYTE	Selects 8-bit or 16-bit mode
$\overline{\text{WP/ACC}}$	Hardware Write Protection/Program Acceleration
V <sub>cc</sub>	Device Power Supply
V <sub>ss</sub>	Device Ground
N.C.	No Internal Connection

## ■ BLOCK DIAGRAM

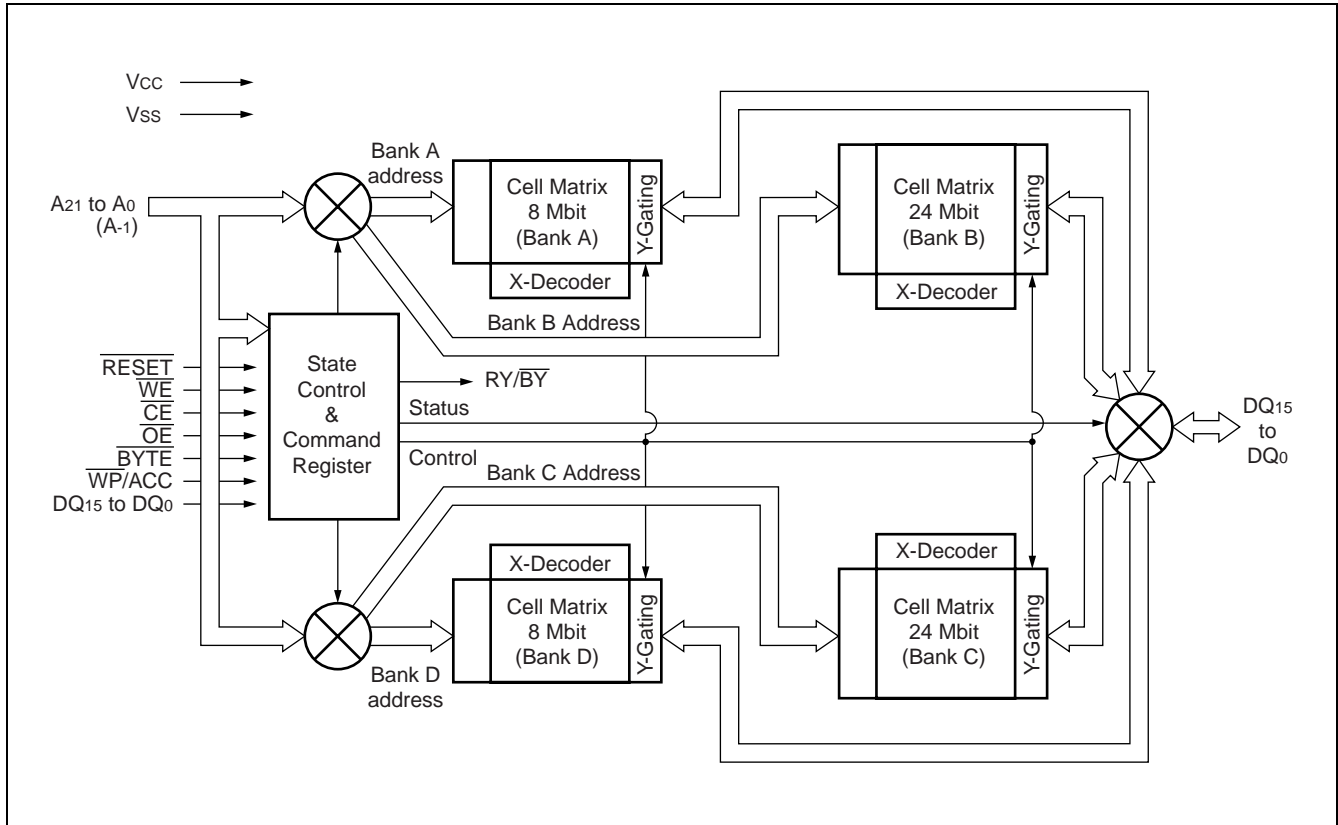

## ■ LOGIC SYMBOL

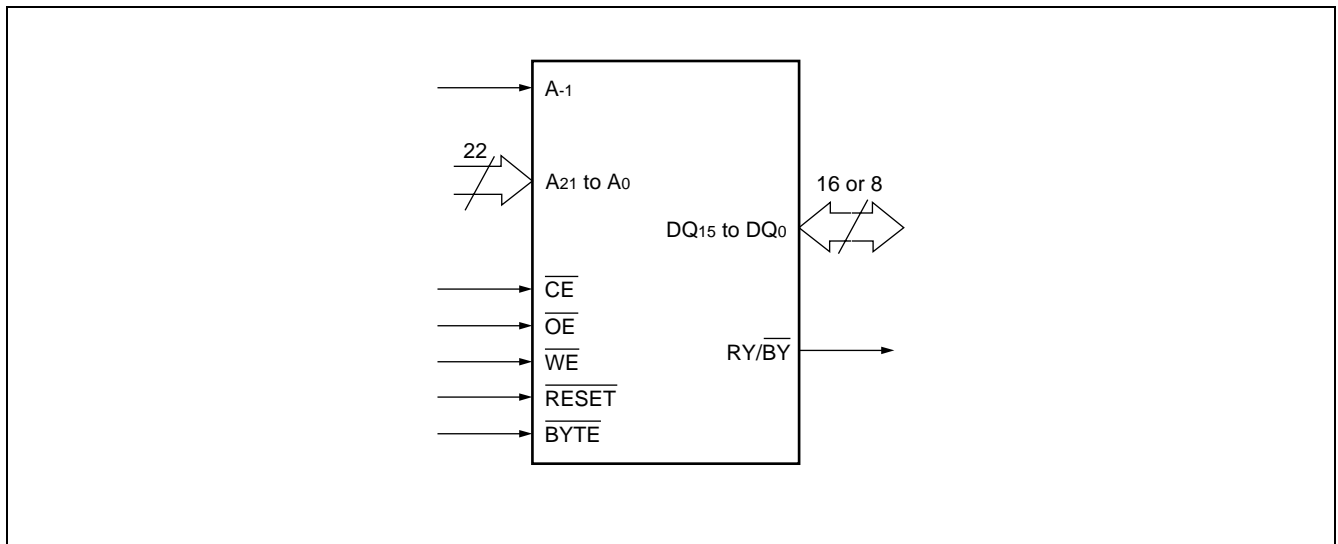

# MBM29DL64DF-70

## ■ DEVICE BUS OPERATION

MBM29DL64DF User Bus Operations Table ( $\overline{\text{BYTE}} = V_{IH}$ )

Operation	$\overline{\text{CE}}$	$\overline{\text{OE}}$	$\overline{\text{WE}}$	A <sub>0</sub>	A <sub>1</sub>	A <sub>2</sub>	A <sub>3</sub>	A <sub>6</sub>	A <sub>9</sub>	DQ <sub>15</sub> to DQ <sub>0</sub>	$\overline{\text{RESET}}$	$\overline{\text{WP/ACC}}$
Standby	H	X	X	X	X	X	X	X	X	High-Z	H	X
Autoselect Manufacturer Code *1	L	L	H	L	L	L	L	L	V <sub>ID</sub>	Code	H	X
Autoselect Device Code *1	L	L	H	H	L	L	L	L	V <sub>ID</sub>	Code	H	X
Extended Autoselect Device Code *1	L	L	H	L	H	H	H	L	V <sub>ID</sub>	Code	H	X
	L	L	H	H	H	H	H	L	V <sub>ID</sub>	Code	H	X
Read *3	L	L	H	A <sub>0</sub>	A <sub>1</sub>	A <sub>2</sub>	A <sub>3</sub>	A <sub>6</sub>	A <sub>9</sub>	D <sub>OUT</sub>	H	X
Output Disable	L	H	H	X	X	X	X	X	X	High-Z	H	X
Write (Program/Erase)	L	H	L	A <sub>0</sub>	A <sub>1</sub>	A <sub>2</sub>	A <sub>3</sub>	A <sub>6</sub>	A <sub>9</sub>	D <sub>IN</sub>	H	X
Enable Sector Group Protection *2, *4	L	V <sub>ID</sub>		L	H	L	L	L	V <sub>ID</sub>	X	H	X
Verify Sector Group Protection *2, *4	L	L	H	L	H	L	L	L	V <sub>ID</sub>	Code	H	X
Temporary Sector Group Unprotection *5	X	X	X	X	X	X	X	X	X	X	V <sub>ID</sub>	X
Reset (Hardware) /Standby	X	X	X	X	X	X	X	X	X	High-Z	L	X
Boot Block Sector Write Protection *6	X	X	X	X	X	X	X	X	X	X	X	L

Legend : L = V<sub>IL</sub>, H = V<sub>IH</sub>, X = V<sub>IL</sub> or V<sub>IH</sub>,  = Pulse input. See “■DC CHARACTERISTICS” for voltage levels.

\*1 : Manufacturer and device codes are accessed via a command register write sequence. See “Command Definitions Table”.

\*2 : Refer to “Sector Group Protection” in ■FUNCTIONAL DESCRIPTION.

\*3 :  $\overline{\text{WE}}$  can be V<sub>IL</sub> if  $\overline{\text{OE}}$  is V<sub>IL</sub>,  $\overline{\text{OE}}$  at V<sub>IH</sub> initiates the write operations.

\*4 : V<sub>CC</sub> = 2.7 V to 3.6 V

\*5 : Also used for the extended sector group protection.

\*6 : Protects “outermost” 2 × 4 Kwords on both ends of the boot block sectors (SA0, SA1, SA140, SA141) .



MBM29DL64DF User Bus Operations Table ( $\overline{\text{BYTE}} = V_{\text{IL}}$ )

Operation	$\overline{\text{CE}}$	$\overline{\text{OE}}$	$\overline{\text{WE}}$	DQ <sub>15</sub> / A <sub>-1</sub>	A <sub>0</sub>	A <sub>1</sub>	A <sub>2</sub>	A <sub>3</sub>	A <sub>6</sub>	A <sub>9</sub>	DQ <sub>7</sub> to DQ <sub>0</sub>	$\overline{\text{RESET}}$	WP/ ACC
Standby	H	X	X	X	X	X	X	X	X	X	High-Z	H	X
Autoselect Manufacturer Code *1	L	L	H	L	L	L	L	L	L	V <sub>ID</sub>	Code	H	X
Autoselect Device Code *1	L	L	H	L	H	L	L	L	L	V <sub>ID</sub>	Code	H	X
Extended Autoselect Device Code *1	L	L	H	L	L	H	H	H	L	V <sub>ID</sub>	Code	H	X
	L	L	H	L	H	H	H	H	L	V <sub>ID</sub>	Code	H	X
Read *3	L	L	H	A <sub>-1</sub>	A <sub>0</sub>	A <sub>1</sub>	A <sub>2</sub>	A <sub>3</sub>	A <sub>6</sub>	A <sub>9</sub>	D <sub>OUT</sub>	H	X
Output Disable	L	H	H	X	X	X	X	X	X	X	High-Z	H	X
Write (Program/Erase)	L	H	L	A <sub>-1</sub>	A <sub>0</sub>	A <sub>1</sub>	A <sub>2</sub>	A <sub>3</sub>	A <sub>6</sub>	A <sub>9</sub>	D <sub>IN</sub>	H	X
Enable Sector Group Protection *2, *4	L	V <sub>ID</sub>	$\overline{\text{P}}\overline{\text{P}}$	L	L	H	L	L	L	V <sub>ID</sub>	X	H	X
Verify Sector Group Protection *2, *4	L	L	H	L	L	H	L	L	L	V <sub>ID</sub>	Code	H	X
Temporary Sector Group Unprotection *5	X	X	X	X	X	X	X	X	X	X	X	V <sub>ID</sub>	X
Reset (Hardware) / Standby	X	X	X	X	X	X	X	X	X	X	High-Z	L	X
Boot Block Sector Write Protection *6	X	X	X	X	X	X	X	X	X	X	X	X	L

Legend : L = V<sub>IL</sub>, H = V<sub>IH</sub>, X = V<sub>IL</sub> or V<sub>IH</sub>,  $\overline{\text{P}}\overline{\text{P}}$  = Pulse input. See “■DC CHARACTERISTICS” for voltage levels.

\*1 : Manufacturer and device codes are accessed via command register write sequence. See “Command Definitions Table”.

\*2 : Refer to “Sector Group Protection” in ■FUNCTIONAL DESCRIPTION.

\*3 :  $\overline{\text{WE}}$  can be V<sub>IL</sub> if  $\overline{\text{OE}}$  is V<sub>IL</sub>,  $\overline{\text{OE}}$  at V<sub>IH</sub> initiates the write operations.

\*4 : V<sub>CC</sub> = 2.7 V to 3.6 V

\*5 : Also used for extended sector group protection.

\*6 : Protect “outermost” 2 × 8K bytes on both ends of the boot block sectors (SA0, SA1, SA140, SA141) .

# MBM29DL64DF-70

MBM29DL64DF Command Definitions Table \*1

Command Sequence		Bus Write Cycles Req'd	First Bus Write Cycle		Second Bus Write Cycle		Third Bus Write Cycle		Fourth Bus Read/Write Cycle		Fifth Bus Write Cycle		Sixth Bus Write Cycle	
			Addr.	Data	Addr.	Data	Addr.	Data	Addr.	Data	Addr.	Data	Addr.	Data
Read/Reset *2	Word	1	XXXh	F0h	—	—	—	—	—	—	—	—	—	—
	Byte													
Read/Reset*2	Word	3	555h	AAh	2AAh	55h	555h	F0h	RA*12	*12 RD	—	—	—	—
	Byte		AAAh		555h		AAAh							
Autoselect	Word	3	555h	AAh	2AAh	55h	(BA) 555h	90h	IA*12	ID*12	—	—	—	—
	Byte		AAAh		555h		(BA) AAAh							
Program	Word	4	555h	AAh	2AAh	55h	555h	A0h	PA	PD	—	—	—	—
	Byte		AAAh		555h		AAAh							
Program Suspend		1	BA	B0h	—	—	—	—	—	—	—	—	—	—
Program Resume		1	BA	30h	—	—	—	—	—	—	—	—	—	—
Chip Erase	Word	6	555h	AAh	2AAh	55h	555h	80h	555h	AAh	2AAh	55h	555h	10h
	Byte		AAAh		555h		AAAh		555h		AAAh			
Sector Erase	Word	6	555h	AAh	2AAh	55h	555h	80h	555h	AAh	2AAh	55h	SA	30h
	Byte		AAAh		555h		AAAh		555h		AAAh			
Erase Suspend*3		1	BA	B0h	—	—	—	—	—	—	—	—	—	—
Erase Resume*3		1	BA	30h	—	—	—	—	—	—	—	—	—	—
Set to Fast Mode	Word	3	555h	AAh	2AAh	55h	555h	20h	—	—	—	—	—	—
	Byte		AAAh		555h		AAAh							
Fast Program *4	Word	2	XXXh	A0h	PA	PD	—	—	—	—	—	—	—	—
	Byte													
Reset from Fast Mode *5	Word	2	BA	90h	XXXh	*11 00h	—	—	—	—	—	—	—	—
	Byte													
Extended Sector Group Protection *6, *7	Word	3	XXXh	60h	SPA	60h	SPA	40h	*12 SPA	*12 SD	—	—	—	—
	Byte													
Query *8	Word	1	(BA) 55h	98h	—	—	—	—	—	—	—	—	—	—
	Byte		(BA) AAh											
Hidden-ROM Entry*9	Word	3	555h	AAh	2AAh	55h	555h	88h	—	—	—	—	—	—
	Byte		AAAh		555h		AAAh							

(Continued)

(Continued)

Command Sequence		Bus Write Cycles Req'd	First Bus Write Cycle		Second Bus Write Cycle		Third Bus Write Cycle		Fourth Bus Read/Write Cycle		Fifth Bus Write Cycle		Sixth Bus Write Cycle	
			Addr.	Data	Addr.	Data	Addr.	Data	Addr.	Data	Addr.	Data	Addr.	Data
HiddenROM Program *9, *10	Word	4	555h	AAh	2AAh	55h	555h	A0h	(HRA) PA	PD	—	—	—	—
	Byte		AAAh		555h		AAAh							
HiddenROM Exit *10	Word	4	555h	AAh	2AAh	55h	(HRBA) 555h	90h	XXXh	00h	—	—	—	—
	Byte		AAAh		555h		(HRBA) AAAh							

- \*1 : Command combinations not described in “MBM29DL64DF Command Definitions” are illegal.
- \*2 : Both of these reset commands are equivalent.
- \*3 : Erase Suspend and Erase Resume command are valid only during a sector erase operations.
- \*4 : This command is valid during Fast Mode.
- \*5 : The Reset from Fast mode command is required to return to the Read mode when the device is in Fast mode.
- \*6 : This command is valid while  $\overline{\text{RESET}} = V_{\text{ID}}$  (except during HiddenROM mode) .
- \*7 : Sector Group Address (SGA) with  $(A_6, A_3, A_2, A_1, A_0) = (0, 0, 0, 1, 0)$  .
- \*8 : The valid address are  $A_6$  to  $A_0$ .
- \*9 : The HiddenROM Entry command is required prior to the HiddenROM programming.
- \*10 : This command is valid during HiddenROM mode.
- \*11 : The data “F0h” is also acceptable.
- \*12 : Fourth bus cycle becomes read cycle.

- Notes :
- Address bits  $A_{21}$  to  $A_{11} = X = \text{“H”}$  or  $\text{“L”}$  for all address commands except or Program Address (PA) , Sector Address (SA) , Bank Address (BA) and Sector Group Address (SPA) .
  - Bus operations are defined in “MBM29DL64DF User Bus Operations ( $\overline{\text{BYTE}} = V_{\text{IH}}$ )” and “MBM29DL64DF User Bus Operations ( $\overline{\text{BYTE}} = V_{\text{IL}}$ )” .
  - RA = Address of the memory location to be read
  - IA = Autoselect read address that sets both the bank address specified at  $(A_{21}, A_{20}, A_{19})$  and all the other  $A_6, A_3, A_2, A_1, A_0$  and  $(A_{-1})$  .
  - PA = Address of the memory location to be programmed  
Addresses are latched on the falling edge of the write pulse.
  - SA = Address of the sector to be erased. The combination of  $A_{21}, A_{20}, A_{19}, A_{18}, A_{17}, A_{16}, A_{15}, A_{14}, A_{13}$  and  $A_{12}$  will uniquely select any sector.
  - BA = Bank Address. Address setted by  $A_{21}, A_{20}, A_{19}$  will select Bank A, Bank B, Bank C and Bank D.
  - RD = Data read from location RA during read operation.
  - ID = Device code/manufacture code for the address located by IA.
  - PD = Data to be programmed at location PA. Data is latched on the rising edge of write pulse.
  - SPA = Sector group address to be protected. Set sector group address and  $(A_6, A_3, A_2, A_1, A_0) = (0, 0, 0, 1, 0)$  .
  - SGA = Sector Group Address. The combination of  $A_{21}$  to  $A_{12}$  will uniquely select any sector group.
  - SD = Sector group protection verify data. Output 01h at protected sector group addresses and output 00h at unprotected sector group addresses.
  - HRA = Address of the HiddenROM area  
Word Mode : 000000h to 00007Fh  
Byte Mode : 000000h to 0000FFh
  - HRBA = Bank Address of the HiddenROM area ( $A_{21} = A_{20} = A_{19} = V_{\text{IL}}$ )
  - The system should generate the following address patterns :  
Word Mode : 555h or 2AAh to addresses  $A_{10}$  to  $A_0$   
Byte Mode : AAAh or 555h to addresses  $A_{10}$  to  $A_0$ , and  $A_{-1}$
  - Both Read/Reset commands are functionally equivalent, resetting the device to the read mode.

# MBM29DL64DF-70

**MBM29DL64DF Sector Group Protection Verify Autoselect Codes Table**

Type		A <sub>21</sub> to A <sub>12</sub>	A <sub>6</sub>	A <sub>3</sub>	A <sub>2</sub>	A <sub>1</sub>	A <sub>0</sub>	A <sub>-1</sub> *1	Code (HEX)
Manufacturer's Code	Byte	BA*3	V <sub>IL</sub>	V <sub>IL</sub>	V <sub>IL</sub>	V <sub>IL</sub>	V <sub>IL</sub>	V <sub>IL</sub>	04h
	Word							X	0004h
Device Code	Byte	BA*3	V <sub>IL</sub>	V <sub>IL</sub>	V <sub>IL</sub>	V <sub>IL</sub>	V <sub>IH</sub>	V <sub>IL</sub>	7Eh
	Word							X	227Eh
Extended Device Code*4	Byte	BA*3	V <sub>IL</sub>	V <sub>IH</sub>	V <sub>IH</sub>	V <sub>IH</sub>	V <sub>IH</sub>	V <sub>IL</sub>	02h
	Word							X	2202h
	Byte	BA*3	V <sub>IL</sub>	V <sub>IH</sub>	V <sub>IH</sub>	V <sub>IH</sub>	V <sub>IH</sub>	V <sub>IL</sub>	01h
	Word							X	2201h
Sector Group Protection	Byte	Sector Group Addresses	V <sub>IL</sub>	V <sub>IL</sub>	V <sub>IL</sub>	V <sub>IH</sub>	V <sub>IL</sub>	V <sub>IL</sub>	01h*2
	Word							X	0001h*2

\*1 : A<sub>-1</sub> is for Byte mode. At Byte mode, DQ<sub>14</sub> to DQ<sub>8</sub> are High-Z and DQ<sub>15</sub> is A<sub>-1</sub>, the lowest address.

\*2 : Outputs 01h at protected sector group addresses and outputs 00h at unprotected sector group addresses.

\*3 : When V<sub>ID</sub> is applied to A<sub>9</sub>, both Bank 1 and Bank 2 are put into Autoselect mode, which makes simultaneous operation unable to be executed. Consequently, specifying the bank address is not required. However, the bank address needs to be indicated when Autoselect mode is read out at command mode, because then it enables to activate simultaneous operation.

\*4 : At Word mode, a read cycle at address (BA) 01h (at Byte mode, (BA) 02h) outputs device code. When 227Eh (at Byte mode, 7Eh) is output, it indicates that two additional codes, called Extended Device Codes, will be required. Therefore the system may continue reading out these Extended Device Codes at the address of (BA) 0Eh (at Byte mode, (BA) 1Ch) , as well as at (BA) 0Fh (at Byte mode, (BA) 1Eh) .

**Extended Autoselect Code Table**

Type	Code	DQ <sub>15</sub>	DQ <sub>14</sub>	DQ <sub>13</sub>	DQ <sub>12</sub>	DQ <sub>11</sub>	DQ <sub>10</sub>	DQ <sub>9</sub>	DQ <sub>8</sub>	DQ <sub>7</sub>	DQ <sub>6</sub>	DQ <sub>5</sub>	DQ <sub>4</sub>	DQ <sub>3</sub>	DQ <sub>2</sub>	DQ <sub>1</sub>	DQ <sub>0</sub>
Manufacturer's Code	(B)*	04h	A <sub>-1</sub>	HZ	HZ	HZ	HZ	HZ	HZ	0	0	0	0	0	1	0	0
	(W)	0004h	0	0	0	0	0	0	0	0	0	0	0	0	1	0	0
Device Code	(B)*	7Eh	A <sub>-1</sub>	HZ	HZ	HZ	HZ	HZ	HZ	0	1	1	1	1	1	1	0
	(W)	227Eh	0	0	1	0	0	0	1	0	0	1	1	1	1	1	0
Extended Device Code	(B)*	02h	A <sub>-1</sub>	HZ	HZ	HZ	HZ	HZ	HZ	0	0	0	0	0	0	1	0
	(W)	2202h	0	0	1	0	0	0	1	0	0	0	0	0	0	1	0
	(B)*	01h	A <sub>-1</sub>	HZ	HZ	HZ	HZ	HZ	HZ	0	0	0	0	0	0	0	1
	(W)	2201h	0	0	1	0	0	0	1	0	0	0	0	0	0	0	1
Sector Group Protection	(B)*	01h	A <sub>-1</sub>	HZ	HZ	HZ	HZ	HZ	HZ	0	0	0	0	0	0	0	1
	(W)	0001h	0	0	0	0	0	0	0	0	0	0	0	0	0	0	1

(B) : Byte mode  
(W) : Word mode  
HZ : High-Z

\* : At Byte mode, DQ<sub>14</sub> to DQ<sub>8</sub> are High-Z and DQ<sub>15</sub> is A<sub>-1</sub>, the lowest address.

## ■ FLEXIBLE SECTOR-ERASE ARCHITECTURE

Sector Address Table (Bank A)

Bank	Sector	Sector Address										Sector Size (Kbytes/ Kwords)	( × 8) Address Range	( × 16) Address Range
		Bank Address			A <sub>18</sub>	A <sub>17</sub>	A <sub>16</sub>	A <sub>15</sub>	A <sub>14</sub>	A <sub>13</sub>	A <sub>12</sub>			
		A <sub>21</sub>	A <sub>20</sub>	A <sub>19</sub>										
Bank A	SA0	0	0	0	0	0	0	0	0	0	0	8/4	000000h to 001FFFh	000000h to 000FFFh
	SA1	0	0	0	0	0	0	0	0	0	1	8/4	002000h to 003FFFh	001000h to 001FFFh
	SA2	0	0	0	0	0	0	0	0	1	0	8/4	004000h to 005FFFh	002000h to 002FFFh
	SA3	0	0	0	0	0	0	0	0	1	1	8/4	006000h to 007FFFh	003000h to 003FFFh
	SA4	0	0	0	0	0	0	0	1	0	0	8/4	008000h to 009FFFh	004000h to 004FFFh
	SA5	0	0	0	0	0	0	0	1	0	1	8/4	00A000h to 00BFFFh	005000h to 005FFFh
	SA6	0	0	0	0	0	0	0	1	1	0	8/4	00C000h to 00DFFFh	006000h to 006FFFh
	SA7	0	0	0	0	0	0	0	1	1	1	8/4	00E000h to 00FFFFh	007000h to 007FFFh
	SA8	0	0	0	0	0	0	1	X	X	X	64/32	010000h to 01FFFFh	008000h to 00FFFFh
	SA9	0	0	0	0	0	1	0	X	X	X	64/32	020000h to 02FFFFh	010000h to 017FFFh
	SA10	0	0	0	0	0	1	1	X	X	X	64/32	030000h to 03FFFFh	018000h to 01FFFFh
	SA11	0	0	0	0	1	0	0	X	X	X	64/32	040000h to 04FFFFh	020000h to 027FFFh
	SA12	0	0	0	0	1	0	1	X	X	X	64/32	050000h to 05FFFFh	028000h to 02FFFFh
	SA13	0	0	0	0	1	1	0	X	X	X	64/32	060000h to 06FFFFh	030000h to 037FFFh
	SA14	0	0	0	0	1	1	1	X	X	X	64/32	070000h to 07FFFFh	038000h to 03FFFFh
	SA15	0	0	0	1	0	0	0	X	X	X	64/32	080000h to 08FFFFh	040000h to 047FFFh
	SA16	0	0	0	1	0	0	1	X	X	X	64/32	090000h to 09FFFFh	048000h to 04FFFFh
	SA17	0	0	0	1	0	1	0	X	X	X	64/32	0A0000h to 0AFFFFh	050000h to 057FFFh
	SA18	0	0	0	1	0	1	1	X	X	X	64/32	0B0000h to 0BFFFFh	058000h to 05FFFFh
	SA19	0	0	0	1	1	0	0	X	X	X	64/32	0C0000h to 0CFFFFh	060000h to 067FFFh
	SA20	0	0	0	1	1	0	1	X	X	X	64/32	0D0000h to 0DFFFFh	068000h to 06FFFFh
	SA21	0	0	0	1	1	1	0	X	X	X	64/32	0E0000h to 0EFFFFh	070000h to 077FFFh
SA22	0	0	0	1	1	1	1	X	X	X	64/32	0F0000h to 0FFFFFh	078000h to 07FFFFh	

Note : The address range is A<sub>21</sub> : A<sub>-1</sub> if in byte mode (BYTĒ = V<sub>IL</sub>) .  
 The address range is A<sub>21</sub> : A<sub>0</sub> if in word mode (BYTĒ = V<sub>IH</sub>) .

# MBM29DL64DF-70

Sector Address Table (Bank B)

Bank	Sector	Sector Address										Sector Size (Kbytes/ Kwords)	( $\times 8$ ) Address Range	( $\times 16$ ) Address Range
		Bank Address												
		A <sub>21</sub>	A <sub>20</sub>	A <sub>19</sub>	A <sub>18</sub>	A <sub>17</sub>	A <sub>16</sub>	A <sub>15</sub>	A <sub>14</sub>	A <sub>13</sub>	A <sub>12</sub>			
Bank B	SA23	0	0	1	0	0	0	0	X	X	X	64/32	100000h to 10FFFFh	080000h to 087FFFh
	SA24	0	0	1	0	0	0	1	X	X	X	64/32	110000h to 11FFFFh	088000h to 08FFFFh
	SA25	0	0	1	0	0	1	0	X	X	X	64/32	120000h to 12FFFFh	090000h to 097FFFh
	SA26	0	0	1	0	0	1	1	X	X	X	64/32	130000h to 13FFFFh	098000h to 09FFFFh
	SA27	0	0	1	0	1	0	0	X	X	X	64/32	140000h to 14FFFFh	0A0000h to 0A7FFFh
	SA28	0	0	1	0	1	0	1	X	X	X	64/32	150000h to 15FFFFh	0A8000h to 0AFFFFh
	SA29	0	0	1	0	1	1	0	X	X	X	64/32	160000h to 16FFFFh	0B0000h to 0B7FFFh
	SA30	0	0	1	0	1	1	1	X	X	X	64/32	170000h to 17FFFFh	0B8000h to 0BFFFFh
	SA31	0	0	1	1	0	0	0	X	X	X	64/32	180000h to 18FFFFh	0C0000h to 0C7FFFh
	SA32	0	0	1	1	0	0	1	X	X	X	64/32	190000h to 19FFFFh	0C8000h to 0CFFFFh
	SA33	0	0	1	1	0	1	0	X	X	X	64/32	1A0000h to 1AFFFFh	0D0000h to 0D7FFFh
	SA34	0	0	1	1	0	1	1	X	X	X	64/32	1B0000h to 1BFFFFh	0D8000h to 0DFFFFh
	SA35	0	0	1	1	1	0	0	X	X	X	64/32	1C0000h to 1CFFFFh	0E0000h to 0E7FFFh
	SA36	0	0	1	1	1	0	1	X	X	X	64/32	1D0000h to 1DFFFFh	0E8000h to 0EFFFFh
	SA37	0	0	1	1	1	1	0	X	X	X	64/32	1E0000h to 1EFFFFh	0F0000h to 0F7FFFh
	SA38	0	0	1	1	1	1	1	X	X	X	64/32	1F0000h to 1FFFFFh	0F8000h to 0FFFFFh
	SA39	0	1	0	0	0	0	0	X	X	X	64/32	200000h to 20FFFFh	100000h to 107FFFh
	SA40	0	1	0	0	0	0	1	X	X	X	64/32	210000h to 21FFFFh	108000h to 10FFFFh
	SA41	0	1	0	0	0	1	0	X	X	X	64/32	220000h to 22FFFFh	110000h to 117FFFh
	SA42	0	1	0	0	0	1	1	X	X	X	64/32	230000h to 23FFFFh	118000h to 11FFFFh
	SA43	0	1	0	0	1	0	0	X	X	X	64/32	240000h to 24FFFFh	120000h to 127FFFh
	SA44	0	1	0	0	1	0	1	X	X	X	64/32	250000h to 25FFFFh	128000h to 12FFFFh
	SA45	0	1	0	0	1	1	0	X	X	X	64/32	260000h to 26FFFFh	130000h to 137FFFh
	SA46	0	1	0	0	1	1	1	X	X	X	64/32	270000h to 27FFFFh	138000h to 13FFFFh
	SA47	0	1	0	1	0	0	0	X	X	X	64/32	280000h to 28FFFFh	140000h to 147FFFh
	SA48	0	1	0	1	0	0	1	X	X	X	64/32	290000h to 29FFFFh	148000h to 14FFFFh
	SA49	0	1	0	1	0	1	0	X	X	X	64/32	2A0000h to 2AFFFFh	150000h to 157FFFh
	SA50	0	1	0	1	0	1	1	X	X	X	64/32	2B0000h to 2BFFFFh	158000h to 15FFFFh
	SA51	0	1	0	1	1	0	0	X	X	X	64/32	2C0000h to 2CFFFFh	160000h to 167FFFh
	SA52	0	1	0	1	1	0	1	X	X	X	64/32	2D0000h to 2DFFFFh	168000h to 16FFFFh
	SA53	0	1	0	1	1	1	0	X	X	X	64/32	2E0000h to 2EFFFFh	170000h to 177FFFh

(Continued)

(Continued)

Bank	Sector	Sector Address										Sector Size (Kbytes/ Kwords)	( × 8) Address Range	( × 16) Address Range
		Bank Address			A <sub>18</sub>	A <sub>17</sub>	A <sub>16</sub>	A <sub>15</sub>	A <sub>14</sub>	A <sub>13</sub>	A <sub>12</sub>			
		A <sub>21</sub>	A <sub>20</sub>	A <sub>19</sub>										
Bank B	SA54	0	1	0	1	1	1	1	X	X	X	64/32	2F0000h to 2FFFFFFh	178000h to 17FFFFh
	SA55	0	1	1	0	0	0	0	X	X	X	64/32	300000h to 30FFFFh	180000h to 187FFFh
	SA56	0	1	1	0	0	0	1	X	X	X	64/32	310000h to 31FFFFh	188000h to 18FFFFh
	SA57	0	1	1	0	0	1	0	X	X	X	64/32	320000h to 32FFFFh	190000h to 197FFFh
	SA58	0	1	1	0	0	1	1	X	X	X	64/32	330000h to 33FFFFh	198000h to 19FFFFh
	SA59	0	1	1	0	1	0	0	X	X	X	64/32	340000h to 34FFFFh	1A0000h to 1A7FFFh
	SA60	0	1	1	0	1	0	1	X	X	X	64/32	350000h to 35FFFFh	1A8000h to 1AFFFFh
	SA61	0	1	1	0	1	1	0	X	X	X	64/32	360000h to 36FFFFh	1B0000h to 1B7FFFh
	SA62	0	1	1	0	1	1	1	X	X	X	64/32	370000h to 37FFFFh	1B8000h to 1BFFFFh
	SA63	0	1	1	1	0	0	0	X	X	X	64/32	380000h to 38FFFFh	1C0000h to 1C7FFFh
	SA64	0	1	1	1	0	0	1	X	X	X	64/32	390000h to 39FFFFh	1C8000h to 1CFFFFh
	SA65	0	1	1	1	0	1	0	X	X	X	64/32	3A0000h to 3AFFFFh	1D0000h to 1D7FFFh
	SA66	0	1	1	1	0	1	1	X	X	X	64/32	3B0000h to 3BFFFFh	1D8000h to 1DFFFFh
	SA67	0	1	1	1	1	0	0	X	X	X	64/32	3C0000h to 3CFFFFh	1E0000h to 1E7FFFh
	SA68	0	1	1	1	1	0	1	X	X	X	64/32	3D0000h to 3DFFFFh	1E8000h to 1EFFFFh
SA69	0	1	1	1	1	1	0	X	X	X	64/32	3E0000h to 3EFFFFh	1F0000h to 1F7FFFh	
SA70	0	1	1	1	1	1	1	X	X	X	64/32	3F0000h to 3FFFFFFh	1F8000h to 1FFFFFFh	

Note : The address range is A<sub>21</sub> : A<sub>-1</sub> if in byte mode (BYTE = V<sub>IL</sub>) .  
 The address range is A<sub>21</sub> : A<sub>0</sub> if in word mode (BYTE = V<sub>IH</sub>) .

# MBM29DL64DF-70

Sector Address Table (Bank C)

Bank	Sector	Sector Address										Sector Size (Kbytes/ Kwords)	( $\times 8$ ) Address Range	( $\times 16$ ) Address Range
		Bank Address			A <sub>18</sub>	A <sub>17</sub>	A <sub>16</sub>	A <sub>15</sub>	A <sub>14</sub>	A <sub>13</sub>	A <sub>12</sub>			
		A <sub>21</sub>	A <sub>20</sub>	A <sub>19</sub>										
Bank C	SA71	1	0	0	0	0	0	0	X	X	X	64/32	400000h to 40FFFFh	200000h to 207FFFh
	SA72	1	0	0	0	0	0	1	X	X	X	64/32	410000h to 41FFFFh	208000h to 20FFFFh
	SA73	1	0	0	0	0	1	0	X	X	X	64/32	420000h to 42FFFFh	210000h to 217FFFh
	SA74	1	0	0	0	0	1	1	X	X	X	64/32	430000h to 43FFFFh	218000h to 21FFFFh
	SA75	1	0	0	0	1	0	0	X	X	X	64/32	440000h to 44FFFFh	220000h to 227FFFh
	SA76	1	0	0	0	1	0	1	X	X	X	64/32	450000h to 45FFFFh	228000h to 22FFFFh
	SA77	1	0	0	0	1	1	0	X	X	X	64/32	460000h to 46FFFFh	230000h to 237FFFh
	SA78	1	0	0	0	1	1	1	X	X	X	64/32	470000h to 47FFFFh	238000h to 23FFFFh
	SA79	1	0	0	1	0	0	0	X	X	X	64/32	480000h to 48FFFFh	240000h to 247FFFh
	SA80	1	0	0	1	0	0	1	X	X	X	64/32	490000h to 49FFFFh	248000h to 24FFFFh
	SA81	1	0	0	1	0	1	0	X	X	X	64/32	4A0000h to 4AFFFFh	250000h to 257FFFh
	SA82	1	0	0	1	0	1	1	X	X	X	64/32	4B0000h to 4BFFFFh	258000h to 25FFFFh
	SA83	1	0	0	1	1	0	0	X	X	X	64/32	4C0000h to 4CFFFFh	260000h to 267FFFh
	SA84	1	0	0	1	1	0	1	X	X	X	64/32	4D0000h to 4DFFFFh	268000h to 26FFFFh
	SA85	1	0	0	1	1	1	0	X	X	X	64/32	4E0000h to 4EFFFFh	270000h to 277FFFh
	SA86	1	0	0	1	1	1	1	X	X	X	64/32	4F0000h to 4FFFFFh	278000h to 27FFFFh
	SA87	1	0	1	0	0	0	0	X	X	X	64/32	500000h to 50FFFFh	280000h to 287FFFh
	SA88	1	0	1	0	0	0	1	X	X	X	64/32	510000h to 51FFFFh	288000h to 28FFFFh
	SA89	1	0	1	0	0	1	0	X	X	X	64/32	520000h to 52FFFFh	290000h to 297FFFh
	SA90	1	0	1	0	0	1	1	X	X	X	64/32	530000h to 53FFFFh	298000h to 29FFFFh
	SA91	1	0	1	0	1	0	0	X	X	X	64/32	540000h to 54FFFFh	2A0000h to 2A7FFFh
	SA92	1	0	1	0	1	0	1	X	X	X	64/32	550000h to 55FFFFh	2A8000h to 2AFFFFh
	SA93	1	0	1	0	1	1	0	X	X	X	64/32	560000h to 56FFFFh	2B0000h to 2B7FFFh
	SA94	1	0	1	0	1	1	1	X	X	X	64/32	570000h to 57FFFFh	2B8000h to 2BFFFFh
	SA95	1	0	1	1	0	0	0	X	X	X	64/32	580000h to 58FFFFh	2C0000h to 2C7FFFh
	SA96	1	0	1	1	0	0	1	X	X	X	64/32	590000h to 59FFFFh	2C8000h to 2CFFFFh
	SA97	1	0	1	1	0	1	0	X	X	X	64/32	5A0000h to 5AFFFFh	2D0000h to 2D7FFFh
	SA98	1	0	1	1	0	1	1	X	X	X	64/32	5B0000h to 5BFFFFh	2D8000h to 2DFFFFh
	SA99	1	0	1	1	1	0	0	X	X	X	64/32	5C0000h to 5CFFFFh	2E0000h to 2E7FFFh
	SA100	1	0	1	1	1	0	1	X	X	X	64/32	5D0000h to 5DFFFFh	2E8000h to 2EFFFFh
	SA101	1	0	1	1	1	1	0	X	X	X	64/32	5E0000h to 5EFFFFh	2F0000h to 2F7FFFh
	SA102	1	0	1	1	1	1	1	X	X	X	64/32	5F0000h to 5FFFFFh	2F8000h to 2FFFFFh

(Continued)



(Continued)

Bank	Sector	Sector Address										Sector Size (Kbytes/ Kwords)	( $\times 8$ ) Address Range	( $\times 16$ ) Address Range
		Bank Address			A <sub>18</sub>	A <sub>17</sub>	A <sub>16</sub>	A <sub>15</sub>	A <sub>14</sub>	A <sub>13</sub>	A <sub>12</sub>			
		A <sub>21</sub>	A <sub>20</sub>	A <sub>19</sub>										
Bank C	SA103	1	1	0	0	0	0	0	X	X	X	64/32	600000h to 60FFFFh	300000h to 307FFFh
	SA104	1	1	0	0	0	0	1	X	X	X	64/32	610000h to 61FFFFh	308000h to 30FFFFh
	SA105	1	1	0	0	0	1	0	X	X	X	64/32	620000h to 62FFFFh	310000h to 317FFFh
	SA106	1	1	0	0	0	1	1	X	X	X	64/32	630000h to 63FFFFh	318000h to 31FFFFh
	SA107	1	1	0	0	1	0	0	X	X	X	64/32	640000h to 64FFFFh	320000h to 327FFFh
	SA108	1	1	0	0	1	0	1	X	X	X	64/32	650000h to 65FFFFh	328000h to 32FFFFh
	SA109	1	1	0	0	1	1	0	X	X	X	64/32	660000h to 66FFFFh	330000h to 337FFFh
	SA110	1	1	0	0	1	1	1	X	X	X	64/32	670000h to 67FFFFh	338000h to 33FFFFh
	SA111	1	1	0	1	0	0	0	X	X	X	64/32	680000h to 68FFFFh	340000h to 347FFFh
	SA112	1	1	0	1	0	0	1	X	X	X	64/32	690000h to 69FFFFh	348000h to 34FFFFh
	SA113	1	1	0	1	0	1	0	X	X	X	64/32	6A0000h to 6AFFFFh	350000h to 357FFFh
	SA114	1	1	0	1	0	1	1	X	X	X	64/32	6B0000h to 6BFFFFh	358000h to 35FFFFh
	SA115	1	1	0	1	1	0	0	X	X	X	64/32	6C0000h to 6CFFFFh	360000h to 367FFFh
	SA116	1	1	0	1	1	0	1	X	X	X	64/32	6D0000h to 6DFFFFh	368000h to 36FFFFh
	SA117	1	1	0	1	1	1	0	X	X	X	64/32	6E0000h to 6EFFFFh	370000h to 377FFFh
SA118	1	1	0	1	1	1	1	X	X	X	64/32	6F0000h to 6FFFFFFh	378000h to 37FFFFh	

Note : The address range is A<sub>21</sub> : A<sub>-1</sub> if in byte mode (BYTE = V<sub>IL</sub>) .  
 The address range is A<sub>21</sub> : A<sub>0</sub> if in word mode (BYTE = V<sub>IH</sub>) .

# MBM29DL64DF-70

Sector Address Table (Bank D)

Bank	Sector	Sector Address										Sector Size (Kbytes/ Kwords)	( × 8) Address Range	( × 16) Address Range
		Bank Address			A <sub>18</sub>	A <sub>17</sub>	A <sub>16</sub>	A <sub>15</sub>	A <sub>14</sub>	A <sub>13</sub>	A <sub>12</sub>			
		A <sub>21</sub>	A <sub>20</sub>	A <sub>19</sub>										
Bank D	SA119	1	1	1	0	0	0	0	X	X	X	64/32	700000h to 70FFFFh	380000h to 387FFFh
	SA120	1	1	1	0	0	0	1	X	X	X	64/32	710000h to 71FFFFh	388000h to 38FFFFh
	SA121	1	1	1	0	0	1	0	X	X	X	64/32	720000h to 72FFFFh	390000h to 397FFFh
	SA122	1	1	1	0	0	1	1	X	X	X	64/32	730000h to 73FFFFh	398000h to 39FFFFh
	SA123	1	1	1	0	1	0	0	X	X	X	64/32	740000h to 74FFFFh	3A0000h to 3A7FFFh
	SA124	1	1	1	0	1	0	1	X	X	X	64/32	750000h to 75FFFFh	3A8000h to 3AFFFFh
	SA125	1	1	1	0	1	1	0	X	X	X	64/32	760000h to 76FFFFh	3B0000h to 3B7FFFh
	SA126	1	1	1	0	1	1	1	X	X	X	64/32	770000h to 77FFFFh	3B8000h to 3BFFFFh
	SA127	1	1	1	1	0	0	0	X	X	X	64/32	780000h to 78FFFFh	3C0000h to 3C7FFFh
	SA128	1	1	1	1	0	0	1	X	X	X	64/32	790000h to 79FFFFh	3C8000h to 3CFFFFh
	SA129	1	1	1	1	0	1	0	X	X	X	64/32	7A0000h to 7AFFFFh	3D0000h to 3D7FFFh
	SA130	1	1	1	1	0	1	1	X	X	X	64/32	7B0000h to 7BFFFFh	3D8000h to 3DFFFFh
	SA131	1	1	1	1	1	0	0	X	X	X	64/32	7C0000h to 7CFFFFh	3E0000h to 3E7FFFh
	SA132	1	1	1	1	1	0	1	X	X	X	64/32	7D0000h to 7DFFFFh	3E8000h to 3EFFFFh
	SA133	1	1	1	1	1	1	0	X	X	X	64/32	7E0000h to 7EFFFFh	3F0000h to 3F7FFFh
	SA134	1	1	1	1	1	1	1	0	0	0	8/4	7F0000h to 7F1FFFh	3F8000h to 3F8FFFh
	SA135	1	1	1	1	1	1	1	0	0	1	8/4	7F2000h to 7F3FFFh	3F9000h to 3F9FFFh
	SA136	1	1	1	1	1	1	1	0	1	0	8/4	7F4000h to 7F5FFFh	3FA000h to 3FAFFFh
	SA137	1	1	1	1	1	1	1	0	1	1	8/4	7F6000h to 7F7FFFh	3FB000h to 3FBFFFh
	SA138	1	1	1	1	1	1	1	1	0	0	8/4	7F8000h to 7F9FFFh	3FC000h to 3FCFFFh
SA139	1	1	1	1	1	1	1	1	0	1	8/4	7FA000h to 7FBFFFh	3FD000h to 3FDFFFh	
SA140	1	1	1	1	1	1	1	1	1	0	8/4	7FC000h to 7FDFFFh	3FE000h to 3FEFFFh	
SA141	1	1	1	1	1	1	1	1	1	1	8/4	7FE000h to 7FFFFFh	3FF000h to 3FFFFFFh	

Note : The address range is A<sub>21</sub> : A<sub>-1</sub> if in byte mode ( $\overline{\text{BYTE}} = V_{IL}$ ) .  
 The address range is A<sub>21</sub> : A<sub>0</sub> if in word mode ( $\overline{\text{BYTE}} = V_{IH}$ ) .

**Sector Group Address Table**

Sector Group	A <sub>21</sub>	A <sub>20</sub>	A <sub>19</sub>	A <sub>18</sub>	A <sub>17</sub>	A <sub>16</sub>	A <sub>15</sub>	A <sub>14</sub>	A <sub>13</sub>	A <sub>12</sub>	Sectors
SGA0	0	0	0	0	0	0	0	0	0	0	SA0
SGA1	0	0	0	0	0	0	0	0	0	1	SA1
SGA2	0	0	0	0	0	0	0	0	1	0	SA2
SGA3	0	0	0	0	0	0	0	0	1	1	SA3
SGA4	0	0	0	0	0	0	0	1	0	0	SA4
SGA5	0	0	0	0	0	0	0	1	0	1	SA5
SGA6	0	0	0	0	0	0	0	1	1	0	SA6
SGA7	0	0	0	0	0	0	0	1	1	1	SA7
SGA8	0	0	0	0	0	0	1	X	X	X	SA8 to SA10
						1	0				
						1	1				
SGA9	0	0	0	0	1	X	X	X	X	X	SA11 to SA14
SGA10	0	0	0	1	0	X	X	X	X	X	SA15 to SA18
SGA11	0	0	0	1	1	X	X	X	X	X	SA19 to SA22
SGA12	0	0	1	0	0	X	X	X	X	X	SA23 to SA26
SGA13	0	0	1	0	1	X	X	X	X	X	SA27 to SA30
SGA14	0	0	1	1	0	X	X	X	X	X	SA31 to SA34
SGA15	0	0	1	1	1	X	X	X	X	X	SA35 to SA38
SGA16	0	1	0	0	0	X	X	X	X	X	SA39 to SA42
SGA17	0	1	0	0	1	X	X	X	X	X	SA43 to SA46
SGA18	0	1	0	1	0	X	X	X	X	X	SA47 to SA50
SGA19	0	1	0	1	1	X	X	X	X	X	SA51 to SA54
SGA20	0	1	1	0	0	X	X	X	X	X	SA55 to SA58
SGA21	0	1	1	0	1	X	X	X	X	X	SA59 to SA62
SGA22	0	1	1	1	0	X	X	X	X	X	SA63 to SA66
SGA23	0	1	1	1	1	X	X	X	X	X	SA67 to SA70

(Continued)

# MBM29DL64DF-70

(Continued)

Sector Group	A <sub>21</sub>	A <sub>20</sub>	A <sub>19</sub>	A <sub>18</sub>	A <sub>17</sub>	A <sub>16</sub>	A <sub>15</sub>	A <sub>14</sub>	A <sub>13</sub>	A <sub>12</sub>	Sectors
SGA24	1	0	0	0	0	X	X	X	X	X	SA71 to SA74
SGA25	1	0	0	0	1	X	X	X	X	X	SA75 to SA78
SGA26	1	0	0	1	0	X	X	X	X	X	SA79 to SA82
SGA27	1	0	0	1	1	X	X	X	X	X	SA83 to SA86
SGA28	1	0	1	0	0	X	X	X	X	X	SA87 to SA90
SGA29	1	0	1	0	1	X	X	X	X	X	SA91 to SA94
SGA30	1	0	1	1	0	X	X	X	X	X	SA95 to SA98
SGA31	1	0	1	1	1	X	X	X	X	X	SA99 to SA102
SGA32	1	1	0	0	0	X	X	X	X	X	SA103 to SA106
SGA33	1	1	0	0	1	X	X	X	X	X	SA107 to SA110
SGA34	1	1	0	1	0	X	X	X	X	X	SA111 to SA114
SGA35	1	1	0	1	1	X	X	X	X	X	SA115 to SA118
SGA36	1	1	1	0	0	X	X	X	X	X	SA119 to SA122
SGA37	1	1	1	0	1	X	X	X	X	X	SA123 to SA126
SGA38	1	1	1	1	0	X	X	X	X	X	SA127 to SA130
SGA39	1	1	1	1	1	0	0	X	X	X	SA131 to SA133
						0	1				
						1	0				
SGA40	1	1	1	1	1	1	1	0	0	0	SA134
SGA41	1	1	1	1	1	1	1	0	0	1	SA135
SGA42	1	1	1	1	1	1	1	0	1	0	SA136
SGA43	1	1	1	1	1	1	1	0	1	1	SA137
SGA44	1	1	1	1	1	1	1	1	0	0	SA138
SGA45	1	1	1	1	1	1	1	1	0	1	SA139
SGA46	1	1	1	1	1	1	1	1	1	0	SA140
SGA47	1	1	1	1	1	1	1	1	1	1	SA141

**Common Flash Memory Interface Code Table**

Description	A <sub>6</sub> to A <sub>0</sub>	DQ <sub>15</sub> to DQ <sub>0</sub>
Query-unique ASCII string "QRY"	10h 11h 12h	0051h 0052h 0059h
Primary OEM Command Set 02h : AMD/FJ standard type	13h 14h	0002h 0000h
Address for Primary Extended Table	15h 16h	0040h 0000h
Alternate OEM Command Set (00h = not applicable)	17h 18h	0000h 0000h
Address for Alternate OEM Extended Table	19h 1Ah	0000h 0000h
V <sub>CC</sub> Min (write/erase) DQ <sub>7</sub> to DQ <sub>4</sub> : 1 V, DQ <sub>3</sub> to DQ <sub>0</sub> : 100 mV	1Bh	0027h
V <sub>CC</sub> Max (write/erase) DQ <sub>7</sub> to DQ <sub>4</sub> : 1 V, DQ <sub>3</sub> to DQ <sub>0</sub> : 100 mV	1Ch	0036h
V <sub>PP</sub> Min voltage	1Dh	0000h
V <sub>PP</sub> Max voltage	1Eh	0000h
Typical timeout per single byte/word write 2 <sup>N</sup> μs	1Fh	0004h
Typical timeout for Min size buffer write 2 <sup>N</sup> μs	20h	0000h
Typical timeout per individual sector erase 2 <sup>N</sup> ms	21h	000Ah
Typical timeout for full chip erase 2 <sup>N</sup> ms	22h	0000h
Max timeout for byte/word write 2 <sup>N</sup> times typical	23h	0005h
Max timeout for buffer write 2 <sup>N</sup> times typical	24h	0000h
Max timeout per individual sector erase 2 <sup>N</sup> times typical	25h	0004h
Max timeout for full chip erase 2 <sup>N</sup> times typical	26h	0000h
Device Size = 2 <sup>N</sup> byte	27h	0017h
Flash Device Interface description 02h : ×8 / ×16	28h 29h	0002h 0000h
Max number of bytes in multi-byte write = 2 <sup>N</sup>	2Ah 2Bh	0000h 0000h
Number of Erase Block Regions within device	2Ch	0003h
Erase Block Region 1 Information bit 15 to bit 0 : y = number of sectors bit 31 to bit 16 : z = size (z × 256 bytes)	2Dh 2Eh 2Fh 30h	0007h 0000h 0020h 0000h
Erase Block Region 2 Information bit 15 to bit 0 : y = number of sectors bit 31 to bit 16 : z = size (z × 256 bytes)	31h 32h 33h 34h	007Dh 0000h 0000h 0001h

(Continued)

# MBM29DL64DF-70

(Continued)

Description	A <sub>6</sub> to A <sub>0</sub>	DQ <sub>15</sub> to DQ <sub>0</sub>
Erase Block Region 3 Information bit 15 to bit 0 : y = number of sectors bit 31 to bit 16 : z = size (z × 256 bytes)	35h 36h 37h 38h	0007h 0000h 0020h 0000h
Query-unique ASCII string "PRI"	40h 41h 42h	0050h 0052h 0049h
Major version number, ASCII	43h	0031h
Minor version number, ASCII	44h	0033h
Address for command write and process technology DQ <sub>1</sub> , DQ <sub>0</sub> : Address required for command write (00h : required) 04h : Required and 0.17 μm technology DQ <sub>7</sub> to DQ <sub>2</sub> : 0.17 μm process technology	45h	0004h
Erase Suspend 02h = To Read & Write	46h	0002h
Sector Protection 00h = Not Supported X = Number of sectors per group	47h	0001h
Sector Temporary Unprotection 01h = Supported	48h	0001h
Sector Protection Algorithm	49h	0004h
Dual Operation 00h = Not Supported X = Total number of sectors in all banks except Bank 1	4Ah	0077h
Burst Mode Type 00h = Not Supported	4Bh	0000h
Page Mode Type 00h = Not Supported	4Ch	0000h
V <sub>ACC</sub> (Acceleration) Supply Minimum DQ <sub>7</sub> to DQ <sub>4</sub> : 1 V, DQ <sub>3</sub> to DQ <sub>0</sub> : 100 mV	4Dh	0085h
V <sub>ACC</sub> (Acceleration) Supply Maximum DQ <sub>7</sub> to DQ <sub>4</sub> : 1 V, DQ <sub>3</sub> to DQ <sub>0</sub> : 100 mV	4Eh	0095h
Boot Type	4Fh	0001h
Program Suspend 01h = Supported	50h	0001h
Bank Organization X = Number of Banks	57h	0004h
Bank A Region Information X = Number of sectors in Bank A	58h	0017h
Bank B Region Information X = Number of sectors in Bank B	59h	0030h
Bank C Region Information X = Number of sectors in Bank C	5Ah	0030h
Bank D Region Information X = Number of sectors in Bank D	5Bh	0017h

## FUNCTIONAL DESCRIPTION

### Simultaneous Operation

The device features functions that enable data reading of one memory bank while a program or erase operation is in progress in the other memory bank (simultaneous operation), in addition to conventional features (read, program, erase, erase-suspend read, and erase-suspend program). The bank is selected by bank address ( $A_{21}$ ,  $A_{20}$ ,  $A_{19}$ ) with zero latency. The device consists of the following four banks:

Bank A :  $8 \times 8$  KB and  $15 \times 64$  KB; Bank B :  $48 \times 64$  KB; Bank C :  $48 \times 64$  KB; Bank D :  $8 \times 8$  KB and  $15 \times 64$  KB.

The device can execute simultaneous operations between Bank 1, a bank chosen from among the four banks, and Bank 2, a bank consisting of the three remaining banks (see "FlexBank™ Architecture".) This is what we call "FlexBank", for example, the rest of banks B, C and D to let the system read while Bank A is in the process of program (or erase) operation. However the different types of operations for the three banks are not allowed, e.g., Bank A writing, Bank B erasing, and Bank C reading out. With this "FlexBank", as described in "Example of Virtual Banks Combination", the system gets to select from four combinations of data volume for Bank 1 and Bank 2, which works well to meet the system requirement. The simultaneous operation cannot execute multi-function mode in the same bank. "Simultaneous Operation" shows the possible combinations for simultaneous operation (refer to "(8) Bank-to-Bank Read/Write Timing Diagram" in ■TIMING DIAGRAM.)

**FlexBank™ Architecture Table**

Bank Splits	Bank 1		Bank 2	
	Volume	Combination	Volume	Combination
1	8 Mbit	Bank A	56 Mbit	Bank B, C, D
2	24 Mbit	Bank B	40 Mbit	Bank A, C, D
3	24 Mbit	Bank C	40 Mbit	Bank A, B, D
4	8 Mbit	Bank D	56 Mbit	Bank A, B, C

**Example of Virtual Banks Combination Table**

Bank Splits	Bank 1			Bank 2		
	Volume	Combination	Sector Size	Volume	Combination	Sector Size
1	8 Mbit	Bank A	$8 \times 8$ Kbyte/4 Kword + $15 \times 64$ Kbyte/32 Kword	56 Mbit	Bank B + Bank C + Bank D	$8 \times 8$ Kbyte/4 Kword + $111 \times 64$ Kbyte/32 Kword
2	16 Mbit	Bank A + Bank D	$16 \times 8$ Kbyte/4 Kword + $30 \times 64$ Kbyte/32 Kword	48 Mbit	Bank B + Bank C	$96 \times 64$ Kbyte/32 Kword
3	24 Mbit	Bank B	$48 \times 64$ Kbyte/32 Kword	40 Mbit	Bank A + Bank C + Bank D	$16 \times 8$ Kbyte/4 Kword + $78 \times 64$ Kbyte/32 Kword
4	32 Mbit	Bank A + Bank B	$8 \times 8$ Kbyte/4 Kword + $63 \times 64$ Kbyte/32 Kword	32 Mbit	Bank C + Bank D	$8 \times 8$ Kbyte/4 Kword + $63 \times 64$ Kbyte/32 Kword

Note : When multiple sector erase over several banks is operated, the system cannot read out of the bank to which a sector being erased belongs. For example, suppose that erasing is taking place at both Bank A and Bank B, neither Bank A nor Bank B is read out. They output the sequence flag once they are selected. Meanwhile the system would get to read from either Bank C or Bank D.

**Simultaneous Operation Table**

Case	Bank 1 Status	Bank 2 Status
1	Read mode	Read mode
2	Read mode	Autoselect mode
3	Read mode	Program mode
4	Read mode	Erase mode *
5	Autoselect mode	Read mode
6	Program mode	Read mode
7	Erase mode *	Read mode

\* : By writing erase suspend command on the bank address of sector being erased, the erase operation becomes suspended so that it enables reading from or programming the remaining sectors.

Note : Bank 1 and Bank 2 are divided for the sake of convenience at Simultaneous Operation. The Bank consists of 4 banks, Bank A, Bank B, BankC and Bank D. Bank Address (BA) means to specify each of the Banks.

### Read Mode

The device has two control functions required to obtain data at the outputs.  $\overline{CE}$  is the power control and used for a device selection.  $\overline{OE}$  is the output control and used to gate data to the output pins.

Address access time ( $t_{ACC}$ ) is equal to the delay from stable addresses to valid output data. The chip enable access time ( $t_{CE}$ ) is the delay from stable addresses and stable  $\overline{CE}$  to valid data at the output pins. The output enable access time is the delay from the falling edge of  $\overline{OE}$  to valid data at the output pins, assuming the addresses have been stable for at least  $t_{ACC-tOE}$  time. When reading out data without changing addresses after power-up, it is required to input hardware reset or to change  $\overline{CE}$  pin from "H" to "L"

### Standby Mode

There are two ways to implement the standby mode on the device, one using both the  $\overline{CE}$  and  $\overline{RESET}$  pins, and the other via the  $\overline{RESET}$  pin only.

When using both pins, CMOS standby mode is achieved with  $\overline{CE}$  and  $\overline{RESET}$  input held at  $V_{CC} \pm 0.3$  V. Under this condition the current consumed is less than 5  $\mu$ A Max. During Embedded Algorithm operation,  $V_{CC}$  active current ( $I_{CC2}$ ) is required even when  $\overline{CE} = "H"$ . The device can be read with standard access time ( $t_{CE}$ ) from either of these standby modes.

When using the  $\overline{RESET}$  pin only, CMOS standby mode is achieved with  $\overline{RESET}$  input held at  $V_{SS} \pm 0.3$  V ( $\overline{CE} = "H"$  or "L"). Under this condition the current consumed is less than 5  $\mu$ A Max. Once the  $\overline{RESET}$  pin is set high, the device requires  $t_{RH}$  as a wake-up time for output to be valid for read access.

During standby mode, the output is in the high impedance state regardless of  $\overline{OE}$  input.

### Automatic Sleep Mode

Automatic sleep mode works to restrain power consumption during read-out of device data. This is useful in applications such as handy terminal which requires low power consumption.

To activate this mode, the device automatically switches itself to low power mode when the device addresses remain stable during after 150 ns from data valid. It is not necessary to control  $\overline{CE}$ ,  $\overline{WE}$  and  $\overline{OE}$  in this mode. In this mode the current consumed is typically 1  $\mu$ A (CMOS Level) .

During simultaneous operation,  $V_{CC}$  active current ( $I_{CC2}$ ) is required.

Since the data are latched during this mode, the data are continuously read out. When the addresses are changed, the mode is automatically canceled and the device reads the data for changed addresses.



## Output Disable

With the  $\overline{OE}$  input at a logic high level ( $V_{IH}$ ), output from the device is disabled. This causes the output pins to be in a high impedance state.

## Autoselect

Autoselect mode allows reading out of binary code and identifies its manufacturer and type. It is intended for use by programming equipment for the purpose of automatically matching the device to be programmed with its corresponding programming algorithm. This mode is functional over the entire temperature range of the device.

To activate this mode, the programming equipment must force  $V_{ID}$  on address pin  $A_9$ . Three identifier bytes may then be sequenced from the device outputs by toggling addresses. All addresses can be either High or Low except  $A_6$ ,  $A_3$ ,  $A_2$ ,  $A_1$ ,  $A_0$  and  $(A_{-1})$ . See User Bus Operations.

The manufacturer and device codes may also be read via the command register, for instances when the device is erased or programmed in a system without access to high voltage on the  $A_9$  pin. The command sequence is illustrated in "Command Definitions".

In the command Autoselect mode, the bank addresses  $BA_i$ ; ( $A_{21}$ ,  $A_{20}$ ,  $A_{19}$ ) must point to a specific bank during the third write bus cycle of the Autoselect command. Then the Autoselect data will be read from that bank while array data can be read from the other bank.

In Word mode, a read cycle from address 00h returns the manufacturer's code (Fujitsu = 04h). A read cycle at address 01h outputs device code. When 227Eh is output, it indicates that two additional codes, called Extended Device Codes is required. Therefore the system may continue reading out these Extended Device Codes at addresses of 0Eh and 0Fh. Notice that the above applies to Word mode; the addresses and codes differ from those of Byte mode (refer to "Sector Group Protection Verify Autoselect Codes Table" and "Extended Autoselect Code Table" in ■DEVICE BUS OPERATION).

In the case of applying  $V_{ID}$  on  $A_9$ , as both Bank 1 and Bank 2 enter Autoselect mode, simultaneous operation cannot be executed.

## Write

Device erasure and programming are accomplished via the command register. The contents of the register serve as input to the internal state machine. The state machine output dictates the device function.

The command register itself does not occupy any addressable memory location. The register is a latch used to store the commands, along with the address and data information needed to execute the command. The command register is written by bringing  $\overline{WE}$  to  $V_{IL}$ , while  $\overline{CE}$  is at  $V_{IL}$  and  $\overline{OE}$  is at  $V_{IH}$ . Addresses are latched on the falling edge of  $\overline{WE}$  or  $\overline{CE}$ , whichever starts later, while data is latched on the rising edge of  $\overline{WE}$  or  $\overline{CE}$ , whichever starts first. Standard microprocessor write timings are used.

Refer to "■AC WRITE CHARACTERISTICS" and Erase/Programming Waveforms for specific timing parameters.

## Sector Group Protection

The device features hardware sector group protection. This feature disables both program and erase operations in any combination of forty eight sector groups of memory. See "Sector Group Address Table". The user's side can use sector group protection using programming equipment. The device is shipped with all sector groups unprotected.

To activate it, the programming equipment must force  $V_{ID}$  on address pin  $A_9$  and control pin  $\overline{OE}$ ,  $\overline{CE} = V_{IL}$  and  $A_6 = A_3 = A_2 = A_0 = V_{IL}$ ,  $A_1 = V_{IH}$ . The sector group addresses ( $A_{21}$ ,  $A_{20}$ ,  $A_{19}$ ,  $A_{18}$ ,  $A_{17}$ ,  $A_{16}$ ,  $A_{15}$ ,  $A_{14}$ ,  $A_{13}$  and  $A_{12}$ ) should be set to the sector to be protected. Sector Address Tables (Bank A to Bank D) define the sector address for each of the one hundred forty-two (142) individual sectors, and Sector Group Address Table defines the sector group address for each of the forty eight (48) individual group sectors. Programming of the protection circuitry begins on the falling edge of the  $\overline{WE}$  pulse and is terminated with the rising edge of the same. Sector group addresses must be held constant during the  $\overline{WE}$  pulse. See Sector Group Protection waveforms and algorithms.

To verify programming of the protection circuitry, the programming equipment must force  $V_{ID}$  on address pin  $A_9$  with  $\overline{CE}$  and  $\overline{OE}$  at  $V_{IL}$  and  $\overline{WE}$  at  $V_{IH}$ . Scanning the sector group addresses ( $A_{21}$ ,  $A_{20}$ ,  $A_{19}$ ,  $A_{18}$ ,  $A_{17}$ ,  $A_{16}$ ,  $A_{15}$ ,  $A_{14}$ ,  $A_{13}$  and  $A_{12}$ ) while ( $A_6$ ,  $A_3$ ,  $A_2$ ,  $A_1$ ,  $A_0$ ) = (0, 0, 0, 1, 0) produces a logical "1" code at device output  $DQ_0$  for a protected sector. Otherwise the device produces "0" for unprotected sectors. In this mode, the lower order

addresses, except for  $A_6$ ,  $A_3$ ,  $A_2$ ,  $A_1$  and  $A_0$  are DON'T CARES. Address locations with  $A_1 = V_{IL}$  are reserved for Autoselect manufacturer and device codes.  $A_{-1}$  requires applying to  $V_{IL}$  on byte mode.

Whether the sector group is protected in the system can be determined by writing an Autoselect command. Performing a read operation at the address location (BA) XX02h, where the higher order addresses ( $A_{21}$ ,  $A_{20}$ ,  $A_{19}$ ,  $A_{18}$ ,  $A_{17}$ ,  $A_{16}$ ,  $A_{15}$ ,  $A_{14}$ ,  $A_{13}$ , and  $A_{12}$ ) are the desired sector group address, will produce a logical "1" at  $DQ_0$  for a protected sector group. Note that the bank addresses ( $A_{21}$ ,  $A_{20}$ ,  $A_{19}$ ) must be pointing to a specific bank during the third write bus cycle of the Autoselect command. Then the Autoselect data can be read from that bank while array data can still be read from the other bank. To read Autoselect data from the other bank, it must be reset to read mode and then write the Autoselect command to the other bank. See Sector Group Protection Verify Autoselect Codes.

## Temporary Sector Group Unprotection

This feature allows temporary unprotection of previously protected sector groups of the device in order to change data. The Sector Group Unprotection mode is activated by setting the  $\overline{RESET}$  pin to high voltage ( $V_{ID}$ ). During this mode, formerly protected sector groups can be programmed or erased by selecting the sector group addresses. Once the  $V_{ID}$  is taken away from the  $\overline{RESET}$  pin, all the previously protected sector groups will be protected again. Refer to "(6) Temporary Sector Group Unprotection Algorithm" in ■FLOW CHART.

## RESET

### Hardware Reset

The device is reset by driving the  $\overline{RESET}$  pin to  $V_{IL}$ . The  $\overline{RESET}$  pin works pulse requirement and has to be kept low ( $V_{IL}$ ) for at least "trp" in order to properly reset the internal state machine. Any operation in the process of being executed is terminated and the internal state machine is reset to the read mode "tready" after the  $\overline{RESET}$  pin is driven low. Furthermore once the  $\overline{RESET}$  pin goes high the device requires an additional "trh" before it allows read access. When the  $\overline{RESET}$  pin is low, the device will be in the standby mode for the duration of the pulse and all the data output pins are tri-stated. If a hardware reset occurs during a program or erase operation, the data at that particular location is corrupted. Please note that the  $RY/\overline{BY}$  output signal should be ignored during the  $\overline{RESET}$  pulse. See "(11)  $\overline{RESET}$ ,  $RY/\overline{BY}$  Timing Diagram" in ■TIMING DIAGRAM for the timing diagram. Refer to "Temporary Sector Group Unprotection" for additional functionality.

## Byte/Word Configuration

$\overline{BYTE}$  pin selects Byte (8-bit) mode or Word (16-bit) mode for the device. When this pin is driven high, the device operates in Word (16-bit) mode. Data is read and programmed at  $DQ_{15}$  to  $DQ_0$ . When this pin is driven low, the device operates in Byte (8-bit) mode. In this mode the  $DQ_{15}/A_{-1}$  pin becomes the lowest address bit, and  $DQ_{14}$  to  $DQ_8$  bits are tri-stated. However the command bus cycle is always an 8-bit operation and hence commands are written at  $DQ_7$  to  $DQ_0$  and  $DQ_{15}$  to  $DQ_8$  bits are ignored. Refer to Timing Diagram for Word Mode/Byte Mode Configuration.

## Boot Block Sector Protection

The Write Protection function provides a hardware method of protecting certain boot sectors without using  $V_{ID}$ . This function is one of two provided by the  $\overline{WP}/ACC$  pin.

If the system asserts  $V_{IL}$  on the  $\overline{WP}/ACC$  pin, the device disables program and erase functions in the two outermost 8 Kbytes on both ends of boot sectors ( $SA_0$ ,  $SA_1$ ,  $SA_{140}$ , and  $SA_{141}$ ) independently of whether those sectors are protected or unprotected using the method described in "Sector Group Protection."

If the system asserts  $V_{IH}$  on the  $\overline{WP}/ACC$  pin, the device reverts to whether the two outermost 8 Kbyte on both ends of boot sectors were last set to be protected or unprotected. Sector group protection or unprotection for these four sectors depends on whether they were last protected or unprotected using the method described in "Sector Group Protection."

## Accelerated Program Operation

The device offers accelerated program operation which enables programming in high speed. If the system asserts  $V_{ACC}$  to the  $\overline{WP}/ACC$  pin, the device automatically enters the acceleration mode and the time required for program operation reduces to about 60%. This function is primarily intended to allow high speed programming, so caution is needed as the sector group temporarily becomes unprotected.

The system uses a fast program command sequence when programming during acceleration mode.

Set command to fast mode and reset command from fast mode are not necessary. When the device enters the acceleration mode, the device is automatically set to fast mode. Therefore the present sequence could be used for programming and detection of completion during acceleration mode.

Removing  $V_{ACC}$  from the  $\overline{WP}/ACC$  pin returns the device to normal operation. Do not remove  $V_{ACC}$  from  $\overline{WP}/ACC$  pin while programming. See “(18) Accelerated Program Timing Diagram” in ■TIMING DIAGRAM.

Erase operation at Acceleration mode is strictly prohibited.

## ■ COMMAND DEFINITIONS

Device operations are selected by writing specific address and data sequences into the command register. Some commands require Bank Address (BA) input. When command sequences are input into a bank reading, the commands have priority over the reading. ■DEVICE BUS OPERATION table shows the valid register command sequences. Note that the Erase Suspend (B0h) and Erase Resume (30h) commands are valid only while the Sector Erase operation is in progress. Also the Program Suspend (B0h) and Program Resume (30h) commands are valid only while the Program operation is in progress. Furthermore Read/Reset commands are functionally equivalent, resetting the device to the read mode. Note that commands are always written at DQ<sub>7</sub> to DQ<sub>0</sub> and DQ<sub>15</sub> to DQ<sub>8</sub> bits are ignored.

### Read/Reset Command

In order to return from Autoselect mode or Exceeded Timing Limits (DQ<sub>5</sub> = 1) to Read/Reset mode, the Read/Reset operation is initiated by writing the Read/Reset command sequence into the command register. Microprocessor read cycles retrieve array data from the memory. The device remains enabled for reads until the command register contents are altered.

The device automatically powers-up in the Read/Reset state. In this case a command sequence is not required in order to read data. Standard microprocessor read cycles will retrieve array data. This default value ensures that no spurious alteration of the memory content occurs during the power transition. Refer to “■AC CHARACTERISTICS” and “■TIMING DIAGRAM” for the specific timing parameters.

### Autoselect Command

Flash memories are designed for use in applications where the local CPU alters memory contents. Therefore manufacture and device codes must be accessible while the device resides in the target system. PROM programmers typically access the signature codes by raising A<sub>9</sub> to a higher voltage. However multiplexing high voltage onto the address lines is not generally desired system design practice.

The device contains Autoselect command operation to supplement traditional PROM programming methodology. The operation is initiated by writing the Autoselect command sequence into the command register.

The Autoselect command sequence is initiated first by writing two unlock cycles. This is followed by a third write cycle that contains the bank address (BA) and the Autoselect command. Then the manufacture and device codes can be read from the bank, and actual data from the memory cell can be read from another bank. The higher order address (A<sub>21</sub>, A<sub>20</sub>, A<sub>19</sub>) required for reading out the manufacture and device codes demands the bank address (BA) set at the third write cycle.

Following the command write, in WORD mode, a read cycle from address (BA) 00h returns the manufacturer's code (Fujitsu = 04h) . And a read cycle at address (BA) 01h outputs device code. When 227Eh was output, this indicates that two additional codes, called Extended Device Codes will be required. Therefore the system may continue reading out these Extended Device Codes at the address of (BA) 0Eh, as well as at (BA) 0Fh. Notice that the above applies to WORD mode. The addresses and codes differ from those of BYTE mode (refer to “MBM29DL64DF Sector Group Protection Verify Autoselect Codes” and “Extended Autoselect Code Table” in ■DEVICE BUS OPERATION. )

The sector state (protection or unprotection) will be informed by address (BA) 02h for × 16 ( (BA) 04h for × 8) . Scanning the sector group addresses (A<sub>21</sub>, A<sub>20</sub>, A<sub>19</sub>, A<sub>18</sub>, A<sub>17</sub>, A<sub>16</sub>, A<sub>15</sub>, A<sub>14</sub>, A<sub>13</sub>, and A<sub>12</sub>) while (A<sub>6</sub>, A<sub>3</sub>, A<sub>2</sub>, A<sub>1</sub>, A<sub>0</sub>) = (0, 0, 0, 1, 0) produces a logic “1” at device output DQ<sub>0</sub> for a protected sector group. The programming verification should be performed by verifying sector group protection on the protected sector (see User Bus Operations Tables).

The manufacture and device codes can be read from the selected bank. To read the manufacture and device codes and sector group protection status from a non-selected bank, it is necessary to write the Read/Reset command sequence into the register. Autoselect command should then be written into the bank to be read.

If the software (program code) for Autoselect command is stored in the Flash memory, the device and manufacture codes should be read from the other bank, which does not contain the software.

To terminate the operation, write the Read/Reset command sequence into the register. To execute the Autoselect command during the operation, Read/Reset command sequence must be written before the Autoselect command.

## Byte/Word Programming

The device is programmed on a byte-by-byte (or word-by-word) basis. Programming is a four bus cycle operation. There are two “unlock” write cycles. These are followed by the program set-up command and data write cycles. Addresses are latched on the falling edge of  $\overline{CE}$  or  $\overline{WE}$ , whichever happens later, and the data is latched on the rising edge of  $\overline{CE}$  or  $\overline{WE}$ , whichever happens first. The rising edge of  $\overline{CE}$  or  $\overline{WE}$  (whichever happens first) starts programming. Upon executing the Embedded Program Algorithm command sequence, the system is not required to provide further controls or timings. The device automatically provides adequate internally generated program pulses and verify programmed cell margin.

The system can determine program operation status by using  $DQ_7$  ( $\overline{\text{Data Polling}}$ ),  $DQ_6$  (Toggle Bit) or  $RY/\overline{BY}$ . The  $\overline{\text{Data Polling}}$  and Toggle Bit must be performed at the memory location being programmed.

The automatic programming operation is completed when the data on  $DQ_7$  is equivalent to data written to this bit at which the device returns to the read mode and addresses are no longer latched (see “Hardware Sequence Flags”). Therefore the device requires that a valid address to the device be supplied by the system in this particular instance. Hence  $\overline{\text{Data Polling}}$  must be performed at the memory location being programmed.

If hardware reset occurs during the programming operation, the data being written is not guaranteed.

Programming is allowed in any sequence and across sector boundaries. Beware that a data “0” cannot be programmed back to a “1”. Attempting to do so may either hang up the device or result in an apparent success according to the data polling algorithm but a read from Read/Reset mode will show that the data is still “0”. Only erase operations can convert from “0”s to “1”s.

“(1) Embedded Program™ Algorithm” in ■FLOW CHART illustrates the Embedded Program™ Algorithm using typical command strings and bus operations.

## Program Suspend/Resume

The Program Suspend command allows the system to interrupt a program operation so that data can be read from any address. Writing the Program Suspend command (B0h) during the Embedded Program operation immediately suspends the programming. The Program Suspend command is issued during programming operation as well while an erase is suspended. The bank addresses of sector being programmed should be set when writing the Program Suspend command.

When the Program Suspend command is written during programming process, the device halts the program operation within 1  $\mu\text{s}$  and updates the status bits.

After the program operation is suspended, the system can read data from any address. The data at program-suspended address is not valid. Normal read timing and command definitions apply.

After the Program Resume command (30h) is written, the device reverts to programming. The bank addresses of sectors being suspended should be set when writing the Program Resume command. The system can determine the program operation status using the  $DQ_7$  or  $DQ_6$  status bits, just as in the standard program operation. See “Write Operation Status” for more information.

The system may also write the Autoselect command sequence when the device is in the Program Suspend mode. The device allows reading Autoselect codes at the addresses within programming sectors, since the codes are not stored in the memory. When the device exits from the Autoselect mode, the device reverts to the Program Suspend mode, and is ready for another valid operation. See “Autoselect Command” for more information.

The system must write the Program Resume command (address bits are “Bank Address”) to exit from the Program Suspend mode and continue the programming operation. Further writes of the Resume command are ignored. Another Program Suspend command can be written after the device resumes programming.

## Chip Erase

Chip erase is a six bus cycle operation. There are two “unlock” write cycles. These are followed by writing the “set-up” command. Two more “unlock” write cycles are then followed by the chip erase command.

Chip erase does not require the user to program prior to erase. Upon executing the Embedded Erase Algorithm command sequence, the device automatically programs and verifies the entire memory for an all-zero data pattern prior to electrical erase (Preprogram function) . The system is not required to provide any controls or timings during these operations.

The system can determine the erase operation status by using  $DQ_7$  ( $\overline{\text{Data}}$  Polling) ,  $DQ_6$  (Toggle Bit) or  $RY/\overline{BY}$ . The chip erase begins on the rising edge of the last  $\overline{CE}$  or  $\overline{WE}$ , whichever happens first in the command sequence, and terminates when the data on  $DQ_7$  is “1” (see “Write Operation Status” section) , at which the device returns to the read mode.

Chip Erase Time : Sector Erase Time  $\times$  All sectors + Chip Program Time (Preprogramming)

“(2) Embedded Erase™ Algorithm” in ■FLOW CHART illustrates the Embedded Erase™ Algorithm using typical command strings and bus operations.

## Sector Erase

Sector erase is a six bus cycle operation. There are two “unlock” write cycles. These are followed by writing the “set-up” command. Two more “unlock” write cycles are then followed by the Sector Erase command. The sector address (any address location within the desired sector) is latched on the falling edge of  $\overline{CE}$  or  $\overline{WE}$ , whichever starts later, while the command (Data = 30h) is latched on the rising edge of  $\overline{CE}$  or  $\overline{WE}$ , whichever starts first. After time-out of “ $t_{\text{row}}$ ” from the rising edge of the last sector erase command, the sector erase operation begins.

Multiple sectors are erased concurrently by writing the six bus cycle operations on Command Definitions. This sequence is followed by writes of the Sector Erase command to addresses in other sectors desired to be concurrently erased. The time between writes must be less than “ $t_{\text{row}}$ ”. Otherwise that command is not accepted and erasure does not start. It is recommended that processor interrupts be disabled during this time to guarantee such condition. The interrupts can reoccur after the last Sector Erase command is written. A time-out of “ $t_{\text{row}}$ ” from the rising edge of last  $\overline{CE}$  or  $\overline{WE}$ , whichever starts first, initiates the execution of the Sector Erase command (s) . If another falling edge of  $\overline{CE}$  or  $\overline{WE}$ , whichever starts first occurs within the “ $t_{\text{row}}$ ” time-out window, the timer is reset (monitor  $DQ_3$  to determine if the sector erase timer window is still open, see section  $DQ_3$ , Sector Erase Timer) . Resetting the device once execution begins may corrupt the data in the sector. In that case restart the erase on those sectors and allow them to complete. Refer to “Write Operation Status” section for Sector Erase Timer operation. Loading the sector erase buffer may be done in any sequence and with any number of sectors (0 to 141) .

Sector erase does not require the user to program the device before erase. The device automatically programs all memory locations in the sector (s) to be erased prior to electrical erase (Preprogram function) . When erasing a sector, the rest remain unaffected. The system is not required to provide any controls or timings during these operations.

The system can determine the status of the erase operation by using  $DQ_7$  ( $\overline{\text{Data}}$  Polling) ,  $DQ_6$  (Toggle Bit) or  $RY/\overline{BY}$ .

The sector erase begins after the “ $t_{\text{row}}$ ” time-out from the rising edge of  $\overline{CE}$  or  $\overline{WE}$ , whichever starts first, for the last sector erase command pulse and terminates when the data on  $DQ_7$  is “1” (see “Write Operation Status” section) at which the device returns to the read mode.  $\overline{\text{Data}}$  polling and Toggle Bit must be performed at an address within any of the sectors being erased.

Multiple Sector Erase Time = [Sector Erase Time + Sector Program Time (Preprogramming) ]  $\times$  Number of Sector Erase

In case of multiple sector erase across bank boundaries, a read from the bank (read-while-erase) to which sectors being erased belong cannot be performed.

“(2) Embedded Erase™ Algorithm” in ■FLOW CHART illustrates the typical command strings and bus operations.

## Erase Suspend/Resume

The Erase Suspend command allows the user to interrupt Sector Erase operation and then reads data from or programs to a sector not being erased. This command is applicable ONLY during the Sector Erase operation which includes the time-out period for sector erase. Writing the Erase Suspend command (B0h) during the Sector Erase time-out results in immediate termination of the time-out period and suspension of the erase operation.

Writing the Erase Resume command (30h) resumes the erase operation. The bank address of sector being erased or erase-suspended should be set when writing the Erase Suspend or Erase Resume command.

When the Erase Suspend command is written during the Sector Erase operation, the device takes a maximum of “ $t_{SPD}$ ” to suspend the erase operation. When the device enters the erase-suspended mode, the RY/ $\overline{BY}$  output pin is at High-Z and the DQ<sub>7</sub> is at logic “1”, and DQ<sub>6</sub> stops toggling. The user must use the address of the erasing sector for reading DQ<sub>6</sub> and DQ<sub>7</sub> to determine if the erase operation is suspended. Further writes of the Erase Suspend command are ignored.

When the erase operation is suspended, the device defaults to the erase-suspend-read mode. Reading data in this mode is the same as reading from the standard read mode, except that the data must be read from sectors that have not been erase-suspended. Reading successively from the erase-suspended sector while the device is in the erase-suspend-read mode may cause DQ<sub>2</sub> to toggle (see the section on “DQ<sub>2</sub>”).

After entering the erase-suspend-read mode, the user can program the device by writing the appropriate command sequence for Program. This program mode is known as the erase-suspend-program mode. Again it is the same with programming in the regular Program mode, except that the data must be programmed to sectors not being erase-suspended. Reading successively from the erase-suspended sector while the device is in the erase-suspend-program mode may cause DQ<sub>2</sub> to toggle. The end of the erase-suspended Program operation is detected by the RY/ $\overline{BY}$  output pin, Data polling of DQ<sub>7</sub> or by the Toggle Bit I (DQ<sub>6</sub>), which is the same with the regular Program operation. Note that DQ<sub>7</sub> must be read from the Program address while DQ<sub>6</sub> can be read from any address within bank being erase-suspended.

To resume the operation of Sector Erase, the Resume command (30h) should be written to the bank being erase suspended. Any further writes of the Resume command at this point are ignored. Another Erase Suspend command can be written after the chip resumes erasing.

## Fast Mode Set/Reset

Fast Mode function dispenses with the initial two unlock cycles required in the standard program command sequence by writing the Fast Mode command into the command register. In this mode the required bus cycle for programming consists of two bus cycles instead of four in standard program command. Do not write erase command in this mode. The read operation is also executed after exiting from the fast mode. To exit from this mode, write Fast Mode Reset command into the command register. The first cycle must contain the bank address. The  $V_{CC}$  active current is required even if  $\overline{CE} = V_{IH}$  during Fast Mode.

## Fast Programming

During Fast Mode, programming is executed with two bus cycle operation. The Embedded Program Algorithm is executed by writing program set-up command (A0h) and data write cycles (PA/PD). See “(8) Embedded Programming Algorithm for Fast Mode” in ■FLOW CHART. The address of the program set-up command is don't care. Fast Program command, with the exception of its process taken place at the two bus cycles, emulates the conventional programming so that the programming termination can be detected by Data polling of DQ<sub>7</sub>, Toggle Bit I (DQ<sub>6</sub>) and RY/ $\overline{BY}$  output pins.

## Extended Sector Group Protection

In addition to normal sector group protection, the device has Extended Sector Group Protection as extended function. This function enables protection of the sector group by forcing  $V_{ID}$  on  $\overline{RESET}$  pin and writes a command sequence. Unlike conventional procedures, it is not necessary to force  $V_{ID}$  and control timing for control pins. The extended sector group protection requires  $V_{ID}$  on  $\overline{RESET}$  pin only. With this condition the operation is initiated by writing the set-up command (60h) in the command register. Then the sector group addresses pins (A<sub>21</sub>, A<sub>20</sub>, A<sub>19</sub>, A<sub>18</sub>, A<sub>17</sub>, A<sub>16</sub>, A<sub>15</sub>, A<sub>14</sub>, A<sub>13</sub> and A<sub>12</sub>) and (A<sub>6</sub>, A<sub>3</sub>, A<sub>2</sub>, A<sub>1</sub>, A<sub>0</sub>) = (0, 0, 0, 1, 0) should be set to the sector group to be protected (setting  $V_{IL}$  for the other addresses pins is recommended), and an extended sector group

protection command (60h) should be written. A sector group is typically protected in 250  $\mu$ s. To verify programming of the protection circuitry, the sector group addresses pins ( $A_{21}$ ,  $A_{20}$ ,  $A_{19}$ ,  $A_{18}$ ,  $A_{17}$ ,  $A_{16}$ ,  $A_{15}$ ,  $A_{14}$ ,  $A_{13}$  and  $A_{12}$ ) and ( $A_6$ ,  $A_3$ ,  $A_2$ ,  $A_1$ ,  $A_0$ ) = (0, 0, 0, 1, 0) should be set a command (40h) should be written. Following the command write, a logic “1” at device output  $DQ_0$  will produce a protected sector in the read operation. If the output is logic “0”, write the extended sector group protection command (60h) again. To terminate the operation, it is necessary to set  $\overline{\text{RESET}}$  pin to  $V_{IH}$ . (refer to “(17) Extended Sector Group Protection Timing Diagram” in ■TIMING DIAGRAM and “(7) Extended Sector Group Protection Algorithm” in ■FLOW CHART.)

## Query (CFI : Common Flash Memory Interface)

The CFI (Common Flash Memory Interface) specification outlines device and the host system software interrogation handshake, which allows specific vendor-specified software algorithms to be used for entire families of devices. This allows device-independent, JEDEC ID-independent and forward-and backward-compatible software support for the specified flash device families. Refer to Common Flash Memory Interface Code in detail.

The operation is initiated by writing the query command (98h) into the command register. The bank address should be set when writing this command. Then the device information can be read from the bank, and data from the memory cell can be read from the another bank. The higher order address ( $A_{21}$ ,  $A_{20}$ ,  $A_{19}$ ) required for reading out the CFI Codes demands that the bank address (BA) be set at the write cycle. Following the command write, a read cycle from specific address retrieves device information. Note that output data of upper byte ( $DQ_{15}$  to  $DQ_8$ ) is “0” in word mode (16 bit) read. Refer to Common Flash Memory Interface Code. To terminate operation, write the read/reset command sequence into the register.

## HiddenROM Region

The HiddenROM feature provides Flash memory region that the system may access through a new command sequence. This is primarily intended for customers who wish to use an Electronic Serial Number (ESN) in the device with the ESN protected against modification. Once the HiddenROM region is protected, any further modification of that region becomes impossible. This ensures the security of the ESN once the product is shipped to be sold.

The HiddenROM region is 256 bytes in length and is stored at the same address of SA0 in Bank A. The device occupies the address of the byte mode 000000h to 0000FFh (word mode 000000h to 00007Fh) . After the system writes the Enter HiddenROM command sequence, the system reads the HiddenROM region by using the addresses normally occupied by the boot sector (particular area of SA0) . That is, the device sends all commands that would normally be sent to the boot sector (particular area of SA0) to the HiddenROM region. This mode of operation continues until the system issues the Exit HiddenROM command sequence, or until power is removed from the device. On power-up, or following a hardware reset, the device reverts to sending commands to the boot sector.

When reading the HiddenROM region, either change addresses or change  $\overline{\text{CE}}$  pin from “H” to “L”. The same procedure should be taken (changing addresses or  $\overline{\text{CE}}$  pin from “H” to “L”) after the system issues the Exit HiddenROM command sequence to read actual memory cell data.

## HiddenROM Entry Command

The device has a HiddenROM area with One Time Protect function. This area is to enter the security code and to remain once set. Programming is allowed in this area until it is protected. However once protection goes on, unprotecting it is not allowed. Therefore extreme caution is required.

The HiddenROM area is 256 bytes. This area is normally the “outermost” 8 Kbyte boot block area in Bank A. Therefore write the HiddenROM entry command sequence to enter the HiddenROM area. It is called HiddenROM mode when the HiddenROM area appears.

Sectors other than the boot block area SA0 can be read during HiddenROM mode. Read/Program of the HiddenROM area is possible during HiddenROM mode. Write the HiddenROM reset command sequence to exit the HiddenROM mode. The bank address of the HiddenROM should be set on the third cycle of this reset command sequence.

In HiddenROM mode, the simultaneous operation cannot be executed multi-function mode between the HiddenROM area and the Bank A.



## HiddenROM Program Command

To program the data to the HiddenROM area, write the HiddenROM program command sequence during HiddenROM mode. This command is the same with the usual program command, except that it needs to write the command during HiddenROM mode. Therefore the detection of completion method is the same, using the DQ<sub>7</sub> data polling, DQ<sub>6</sub> toggle bit and RY/ $\overline{\text{BY}}$  pin. You should pay attention to the address to be programmed. If an address not in the HiddenROM area is selected, the previous data is deleted.

## HiddenROM Protect Command

There are two methods to protect the HiddenROM area. One of them is to write the sector group protect setup command (60h) , set the sector address in the HiddenROM area and  $(A_6, A_3, A_2, A_1, A_0) = (0, 0, 0, 1, 0)$  , and write the sector group protect command (60h) during the HiddenROM mode. The same command sequence is used because it is the same with the extension sector group protect, except that it is in the HiddenROM mode and does not apply high voltage to the  $\overline{\text{RESET}}$  pin. Refer to “Extended Sector Group Protection” for details of extension sector group protect setting.

The other method is to apply high voltage ( $V_{\text{ID}}$ ) to  $A_9$  and  $\overline{\text{OE}}$ , set the sector address in the HiddenROM area and  $(A_6, A_3, A_2, A_1, A_0) = (0, 0, 0, 1, 0)$  , and apply the write pulse during the HiddenROM mode. To verify the protect circuit, apply high voltage ( $V_{\text{ID}}$ ) to  $A_9$ , specify  $(A_6, A_3, A_2, A_1, A_0) = (0, 0, 0, 1, 0)$  and the sector address in the HiddenROM area, and read. When “1” appears on DQ<sub>0</sub>, the protect setting is completed. “0” will appear on DQ<sub>0</sub> if it is not protected. Apply write pulse again. The same command sequence is used for the above method because other than the HiddenROM mode, it is the same method with the sector group protect previously mentioned. Refer to Sector Group Protection for details of the sector group protect setting.

Take note that other sector groups are affected if an address other than those for the HiddenROM area is selected for the sector group address. Pay close attention that once it is protected, protection CANNOT BE CANCELLED.

## Write Operation Status

Details in “Hardware Sequence Flags” are all the status flags which determine the status of the bank for the current mode operation. The read operation from the bank which does not operate Embedded Algorithm returns data of memory cells. These bits offer a method for determining whether an Embedded Algorithm is properly completed. The information on DQ<sub>2</sub> is address-sensitive. This means that if an address from an erasing sector is consecutively read, the DQ<sub>2</sub> bit will toggle. However, DQ<sub>2</sub> will not toggle if an address from a non-erasing sector is consecutively read. This allows users to determine which sectors are in erase.

The status flag is not output from banks (non-busy banks) that do not execute Embedded Algorithms. For example a bank (busy bank) is executing an Embedded Algorithm. When the read sequence is [1] < busy bank > , [2] < non-busy bank > , [3] < busy bank > , the DQ<sub>6</sub> toggles in the case of [1] and [3]. In case of [2], the data of memory cells are output. In the erase-suspend read mode with the same read sequence, DQ<sub>6</sub> will not be toggled in [1] and [3].

In the erase suspend read mode, DQ<sub>2</sub> is toggled in [1] and [3]. In case of [2], the data of memory cell is output.

**Hardware Sequence Flags Table**

Status		DQ <sub>7</sub>	DQ <sub>6</sub>	DQ <sub>5</sub>	DQ <sub>3</sub>	DQ <sub>2</sub>	
In Progress	Embedded Program Algorithm	$\overline{DQ}_7$	Toggle	0	0	1	
	Embedded Erase Algorithm	0	Toggle	0	1	Toggle *1	
	Erase Suspended Mode	Erase Suspend Read (Erase Suspended Sector)	1	1	0	0	Toggle
		Erase Suspend Read (Non-Erase Suspended Sector)	Data	Data	Data	Data	Data
		Erase Suspend Program (Non-Erase Suspended Sector)	$\overline{DQ}_7$	Toggle	0	0	1 *2
	Program Suspended Mode	Program Suspend Read (Program Suspended Sector)	Data	Data	Data	Data	Data
Program Suspend Read (Non-Program Suspended Sector)		Data	Data	Data	Data	Data	
Exceeded Time Limits	Embedded Program Algorithm	$\overline{DQ}_7$	Toggle	1	0	1	
	Embedded Erase Algorithm	0	Toggle	1	1	N/A	
	Erase Suspended Mode	Erase Suspend Program (Non-Erase Suspended Sector)	$\overline{DQ}_7$	Toggle	1	0	N/A

\*1 : Successive reads from the erasing or erase-suspend sector causes DQ<sub>2</sub> to toggle.

\*2 : Reading from non-erase suspend sector address indicates logic “1” at the DQ<sub>2</sub> bit.

## DQ<sub>7</sub>

### Data Polling

The device features  $\overline{Data}$  Polling as a method to indicate the host that the Embedded Algorithms are in progress or completed. During the Embedded Program Algorithm, an attempt to read the device produces reverse data last written to DQ<sub>7</sub>. Upon completion of the Embedded Program Algorithm, an attempt to read the device produces true data last written to DQ<sub>7</sub>. During the Embedded Erase Algorithm, an attempt to read the device produces a “0” at the DQ<sub>7</sub> output. Upon completion of the Embedded Erase Algorithm, an attempt to read device produces a “1” on DQ<sub>7</sub>. The flowchart for  $\overline{Data}$  Polling (DQ<sub>7</sub>) is shown in “(3)  $\overline{Data}$  Polling Algorithm” in ■FLOW CHART.

For programming, the  $\overline{Data}$  Polling is valid after the rising edge of the fourth write pulse in the four write pulse sequences.

For chip erase and sector erase, the  $\overline{Data}$  Polling is valid after the rising edge of the sixth write pulse in the six write pulse sequences. Data polling also works as a flag to indicate whether the device is in erase-suspend mode. DQ<sub>7</sub> goes from “0” to “1” during erase-suspend mode. Notice that to determine DQ<sub>7</sub> entering erase-suspend mode, indicate the sector address of sector being erased.  $\overline{Data}$  Polling must be performed at sector addresses of sectors being erased, not protected sectors. Otherwise the status may become invalid.

If a program address falls within a protected sector,  $\overline{Data}$  Polling on DQ<sub>7</sub> is active for approximately 1 μs, then that bank returns to the read mode. After an erase command sequence is written, if all sectors selected for erasing are protected,  $\overline{Data}$  Polling on DQ<sub>7</sub> is active for approximately 400 μs, then the bank returns to read mode.

Once the Embedded Algorithm operation is close to being completed, the device data pins (DQ<sub>7</sub>) may change asynchronously while the output enable ( $\overline{OE}$ ) is asserted low. This means that device is driving status information on DQ<sub>7</sub> at one instant, and then that byte’s valid data the next. Depending on when the system samples the DQ<sub>7</sub> output, it may read the status or valid data. Even if device completes the Embedded Algorithm operation and DQ<sub>7</sub> has valid data, data outputs on DQ<sub>6</sub> to DQ<sub>0</sub> may still be invalid. The valid data on DQ<sub>7</sub> to DQ<sub>0</sub> is read on successive read attempts.

The  $\overline{\text{Data}}$  Polling feature is only active during the Embedded Programming Algorithm, Embedded Erase Algorithm, Erase Suspend Mode or sector erase time-out. See  $\overline{\text{Data}}$  Polling timing specifications and diagrams.

## DQ<sub>6</sub>

### Toggle Bit I

The device also features the “Toggle Bit I” as a method to indicate to the host system that the Embedded Algorithms are in progress or completed.

During Embedded Program or Erase Algorithm cycle, successive attempts to read ( $\overline{\text{CE}}$  or  $\overline{\text{OE}}$  toggling) data from the busy bank results in DQ<sub>6</sub> toggling between one and zero. Once the Embedded Program or Erase Algorithm cycle is completed, DQ<sub>6</sub> stops toggling and valid data is read on the next successive attempts. During programming, the Toggle Bit I is valid after the rising edge of the fourth write pulse in the four write pulse sequences. For chip erase and sector erase, the Toggle Bit I is valid after the rising edge of the sixth write pulse in the six write pulse sequences. The Toggle Bit I is active during the sector time out.

In Program Operation, if the sector being written to is protected, the toggle bit toggles for about 1  $\mu\text{s}$  and then stops toggling with data unchanged. In erase operation, the device erases all selected sectors except for protected ones. If all selected sectors are protected, the chip toggles the toggle bit for about 400  $\mu\text{s}$  and then drop back into read mode, having data kept remained.

Either  $\overline{\text{CE}}$  or  $\overline{\text{OE}}$  toggling causes DQ<sub>6</sub> to toggle.

DQ<sub>6</sub> determines whether a sector erase is active or is erase-suspended. When a bank is actively erased (that is, the Embedded Erase Algorithm is in progress), DQ<sub>6</sub> toggles. When a bank enters the Erase Suspend mode, DQ<sub>6</sub> stops toggling. Successive read cycles during erase-suspend-program cause DQ<sub>6</sub> to toggle.

To operate toggle bit function properly,  $\overline{\text{CE}}$  or  $\overline{\text{OE}}$  must be high when bank address is changed.

See “(7) AC Waveforms for Toggle Bit I during Embedded Algorithm Operations” (in ■TIMING DIAGRAM) in for the Toggle Bit I timing specifications and diagrams.

## DQ<sub>5</sub>

### Exceeded Timing Limits

DQ<sub>5</sub> indicates if the program or erase time exceeds the specified limits (internal pulse count). Under these conditions DQ<sub>5</sub> produces “1”. This is a failure condition indicating that the program or erase cycle was not successfully completed.  $\overline{\text{Data}}$  Polling is only operating function of the device under this condition. The  $\overline{\text{CE}}$  circuit partially powers down device under these conditions (to approximately 2 mA). The  $\overline{\text{OE}}$  and  $\overline{\text{WE}}$  pins control the output disable functions as described in User Bus Operations.

The DQ<sub>5</sub> failure condition may also appear if the user tries to program a non-blank location without pre-erase. In this case the device locks out and never completes the Embedded Algorithm operation. Hence the system never reads valid data on DQ<sub>7</sub> bit and DQ<sub>6</sub> never stop toggling. Once the device exceeds timing limits, the DQ<sub>5</sub> bit indicates a “1.” Please note that this is not a device failure condition since the device was incorrectly used. If this occurs, reset device with the command sequence.

## DQ<sub>3</sub>

### Sector Erase Timer

After completion of the initial sector erase command sequence, sector erase time-out begins. DQ<sub>3</sub> remains low until the time-out is completed.  $\overline{\text{Data}}$  Polling and Toggle Bit are valid after the initial sector erase command sequence.

If  $\overline{\text{Data}}$  Polling or the Toggle Bit I indicates that a valid erase command is written, DQ<sub>3</sub> determines whether the sector erase timer window is still open. If DQ<sub>3</sub> is high (“1”) the internally controlled erase cycle begins. If DQ<sub>3</sub> is low (“0”), the device accepts additional sector erase commands. To insure the command is accepted, the system software checks the status of DQ<sub>3</sub> prior to and following each subsequent Sector Erase command. If DQ<sub>3</sub> is high on the second status check, the command may not be accepted.

See Hardware Sequence Flags.

# MBM29DL64DF-70

## DQ<sub>2</sub>

### Toggle Bit II

This toggle bit II, along with DQ<sub>6</sub>, determines whether the device is in the Embedded Erase Algorithm or in Erase Suspend.

Successive reads from the erasing sector causes DQ<sub>2</sub> to toggle during the Embedded Erase Algorithm. If the device is in the erase-suspended-read mode, successive reads from the erase-suspended sector causes DQ<sub>2</sub> to toggle. When the device is in the erase-suspended-program mode, successive reads from the non-erase suspended sector indicates a logic “1” at the DQ<sub>2</sub> bit.

DQ<sub>6</sub> is different from DQ<sub>2</sub> in that DQ<sub>6</sub> toggles only when the standard program or Erase, or Erase Suspend Program operation is in progress. These two status bits, along with that of DQ<sub>7</sub>, operate as follows :

For example DQ<sub>2</sub> and DQ<sub>6</sub> determine if the erase-suspend-read mode is in progress. (DQ<sub>2</sub> toggles while DQ<sub>6</sub> does not.) See also “Toggle Bit Status” table and “DQ<sub>2</sub> vs.DQ<sub>6</sub>” waveform.

Furthermore DQ<sub>2</sub> determines which sector is being erased. At the erase mode, DQ<sub>2</sub> toggles if this bit is read from an erasing sector.

To operate toggle bit function properly,  $\overline{CE}$  or  $\overline{OE}$  must be high when bank address is changed.

### Reading Toggle Bits DQ<sub>6</sub>/DQ<sub>2</sub>

Whenever the system initially begins reading toggle bit status, it must read DQ<sub>7</sub> to DQ<sub>0</sub> at least twice in a row to determine whether a toggle bit is on. Typically the system would note and store the value of the toggle bit after the first read. After the second read, the system compares the new value of the toggle bit with the first. If the toggle bit is not toggling, this indicates that the device completes the program or erase operation. The system reads array data on DQ<sub>7</sub> to DQ<sub>0</sub> on the following read cycle.

However if after the initial two read cycles, the system determines that the toggle bit is still on, the system also should note whether the value of DQ<sub>5</sub> is high (see the section on “DQ<sub>5</sub>”). If it is, the system should then determine again whether the toggle bit is toggling, since the toggle bit may have stopped toggling just as DQ<sub>5</sub> went high. If the toggle bit is no longer toggling, the device successfully completes the program or erase operation. If it is still toggling, the device does not complete the operation successfully, and the system must write the reset command to return to reading array data.

The remaining scenario is that the system initially determines that the toggle bit is toggling and DQ<sub>5</sub> has not gone high. The system continues to monitor the toggle bit and DQ<sub>5</sub> through successive read cycles, determining the status as described in the previous paragraph. Alternatively the system chooses to perform other system tasks. In this case the system must start at the beginning of the algorithm to determine the status of the operation.

**Toggle Bit Status Table**

Mode	DQ <sub>7</sub>	DQ <sub>6</sub>	DQ <sub>2</sub>
Program	$\overline{DQ_7}$	Toggle	1
Erase	0	Toggle	Toggle* <sup>1</sup>
Erase-Suspend Read (Erase-Suspended Sector)	1	1	Toggle
Erase-Suspend Program	$\overline{DQ_7}$	Toggle	1* <sup>2</sup>

\*1 : Successive reads from the erasing or erase-suspend sector cause DQ<sub>2</sub> to toggle.

\*2 : Reading from the non-erase suspend sector address indicates logic “1” at the DQ<sub>2</sub> bit.

## RY/ $\overline{BY}$

### Ready/Busy

The device provides a RY/ $\overline{BY}$  open-drain output pin as a way to indicate that Embedded Algorithms are either in progress or have been completed. When output is low the device is busy with either a program or erase

operation. If output is high, the device is ready to accept any read/write or erase operation. If the device is placed in an Erase Suspend mode, RY/ $\overline{\text{BY}}$  output is high.

During programming, the RY/ $\overline{\text{BY}}$  pin is driven low after the rising edge of the fourth write pulse. During an erase operation, the RY/ $\overline{\text{BY}}$  pin is driven low after the rising edge of the sixth write pulse. RY/ $\overline{\text{BY}}$  pin indicates busy condition during  $\overline{\text{RESET}}$  pulse. Refer to “(10) RY/ $\overline{\text{BY}}$  Timing Diagram during Program/Erase Operation Timing Diagram” and “(11)  $\overline{\text{RESET}}$ , RY/ $\overline{\text{BY}}$  Timing Diagram” in ■TIMING DIAGRAM. RY/ $\overline{\text{BY}}$  pin is pulled high in standby mode.

Since this is an open-drain output, Pull-up resistor needs to be connected to  $V_{\text{CC}}$ ; multiples of devices may be connected to the host system via more than one RY/ $\overline{\text{BY}}$  pin in parallel.

## Data Protection

The device offers protection against accidental erasure or programming caused by spurious system level signals that may exist during power transitions. During power-up the device automatically resets the internal state machine in Read mode. With its control register architecture, alteration of memory contents only occurs after successful completion of specific multi-bus cycle command sequences.

The device also incorporates several features to prevent inadvertent write cycles resulting from  $V_{\text{CC}}$  power-up and power-down transitions or system noise.

## Low $V_{\text{CC}}$ Write Inhibit

To avoid initiation of a write cycle during  $V_{\text{CC}}$  power-up and power-down, the write cycle is locked out for  $V_{\text{CC}}$  less than  $V_{\text{LKO}}$ . If  $V_{\text{CC}} < V_{\text{LKO}}$ , the command register is disabled and all internal program/erase circuits are disabled. Under this condition the device resets to the read mode. Subsequent writes are ignored until the  $V_{\text{CC}}$  level goes higher than  $V_{\text{LKO}}$ . It is the user's responsibility to ensure that the control pins are logically correct to prevent unintentional writes when  $V_{\text{CC}}$  is above  $V_{\text{LKO}}$ .

If the Embedded Erase Algorithm is interrupted, the intervened erasing sector (s) is (are) not valid.

## Write Pulse “Glitch” Protection

Noise pulses of less than 3 ns (typical) on  $\overline{\text{OE}}$ ,  $\overline{\text{CE}}$  or  $\overline{\text{WE}}$  does not initiate write cycle.

## Logical Inhibit

Writing is prohibited by holding any one of  $\overline{\text{OE}} = V_{\text{IL}}$ ,  $\overline{\text{CE}} = V_{\text{IH}}$  or  $\overline{\text{WE}} = V_{\text{IH}}$ . To initiate a write cycle  $\overline{\text{CE}}$  and  $\overline{\text{WE}}$  must be logical zero while  $\overline{\text{OE}}$  is a logical one.

## Power-Up Write Inhibit

Power-up of the device with  $\overline{\text{WE}} = \overline{\text{CE}} = V_{\text{IL}}$  and  $\overline{\text{OE}} = V_{\text{IH}}$  does not accept commands on the rising edge of  $\overline{\text{WE}}$ . Internal state machine is automatically reset to the read mode on power-up.

## Sector Group Protection

Device user is able to protect each sector group individually to store and protect data. Protection circuit voids both program and erase command that are addressed to protect sectors. Any commands to program or erase addressed to protected sector are ignored (see ■FUNCTIONAL DESCRIPTION, Sector Group Protection) .

# MBM29DL64DF-70

## ■ ABSOLUTE MAXIMUM RATINGS

Parameter	Symbol	Rating		Unit
		Min	Max	
Storage Temperature	T <sub>stg</sub>	-55	+125	°C
Ambient Temperature with Power Applied	T <sub>A</sub>	-40	+85	°C
Voltage with Respect to Ground All pins except A <sub>9</sub> , $\overline{\text{OE}}$ , and $\overline{\text{RESET}}$ *1,*2	V <sub>IN</sub> , V <sub>OUT</sub>	-0.5	V <sub>CC</sub> + 0.5	V
Power Supply Voltage *1	V <sub>CC</sub>	-0.5	+4.0	V
A <sub>9</sub> , $\overline{\text{OE}}$ , and $\overline{\text{RESET}}$ *1,*3	V <sub>IN</sub>	-0.5	+13.0	V
$\overline{\text{WP}}/\text{ACC}$ *1,*4	V <sub>ACC</sub>	-0.5	+10.5	V

\*1: Voltage is defined on the basis of V<sub>SS</sub> = GND = 0 V.

\*2: Minimum DC voltage on input or I/O pins is -0.5 V. During voltage transitions, input or I/O pins may undershoot V<sub>SS</sub> to -2.0 V for periods of up to 20 ns. Maximum DC voltage on input or I/O pins is V<sub>CC</sub> + 0.5 V. During voltage transitions, input or I/O pins may overshoot to V<sub>CC</sub> + 2.0 V for periods of up to 20 ns.

\*3: Minimum DC input voltage on A<sub>9</sub>,  $\overline{\text{OE}}$  and  $\overline{\text{RESET}}$  pins is -0.5 V. During voltage transitions, A<sub>9</sub>,  $\overline{\text{OE}}$  and  $\overline{\text{RESET}}$  pins may undershoot V<sub>SS</sub> to -2.0 V for periods of up to 20 ns. Voltage difference between input and supply voltage (V<sub>IN</sub> - V<sub>CC</sub>) does not exceed +9.0 V. Maximum DC input voltage on A<sub>9</sub>,  $\overline{\text{OE}}$  and  $\overline{\text{RESET}}$  pins is +13.0 V which may overshoot to +14.0 V for periods of up to 20 ns.

\*4: Minimum DC input voltage on  $\overline{\text{WP}}/\text{ACC}$  pin is -0.5 V. During voltage transitions,  $\overline{\text{WP}}/\text{ACC}$  pin may undershoot V<sub>SS</sub> to -2.0 V for periods of up to 20 ns. Maximum DC input voltage on  $\overline{\text{WP}}/\text{ACC}$  pin is +10.5 V which may overshoot to +12.0 V for periods of up to 20 ns when V<sub>CC</sub> is applied.

WARNING: Semiconductor devices can be permanently damaged by application of stress (voltage, current, temperature, etc.) in excess of absolute maximum ratings. Do not exceed these ratings.

## ■ RECOMMENDED OPERATING CONDITIONS

Parameter	Symbol	Value		Unit
		Min	Max	
Ambient Temperature	T <sub>A</sub>	-40	+85	°C
Power Supply Voltage*	V <sub>CC</sub>	+2.7	+3.6	V

\* : Voltage is defined on the basis of V<sub>SS</sub> = GND = 0 V.

Note: Operating ranges define those limits between which the proper device function is guaranteed.

WARNING: The recommended operating conditions are required in order to ensure the normal operation of the semiconductor device. All of the device's electrical characteristics are warranted when the device is operated within these ranges.

Always use semiconductor devices within their recommended operating condition ranges. Operation outside these ranges may adversely affect reliability and could result in device failure.

No warranty is made with respect to uses, operating conditions, or combinations not represented on the data sheet. Users considering application outside the listed conditions are advised to contact their FUJITSU representatives beforehand.

## ■ MAXIMUM OVERSHOOT/MAXIMUM UNDERSHOOT

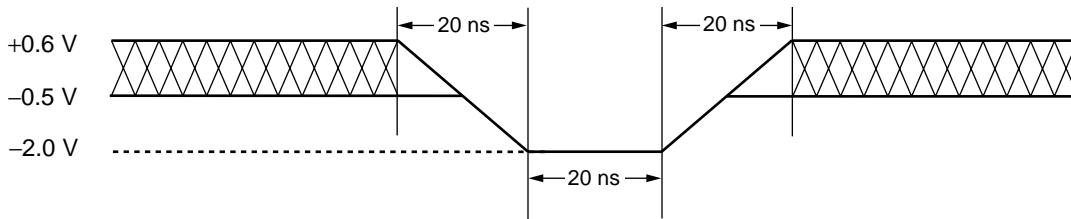

Maximum Undershoot Waveform

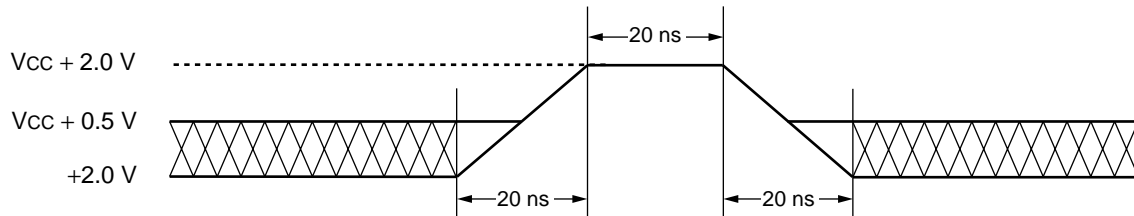

Maximum Overshoot Waveform 1

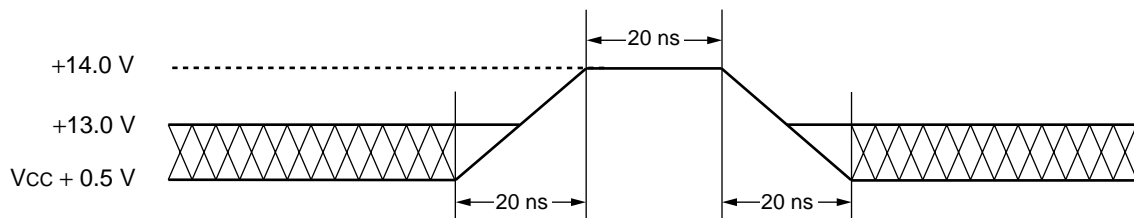

Note : Applicable for  $A_9$ ,  $\overline{OE}$  and  $\overline{RESET}$ .

Maximum Overshoot Waveform 2

# MBM29DL64DF-70

## ■ DC CHARACTERISTICS

Parameter	Symbol	Conditions	Value			Unit	
			Min	Typ	Max		
Input Leakage Current	$I_{LI}$	$V_{IN} = V_{SS} \text{ to } V_{CC}, V_{CC} = V_{CC} \text{ Max}$	-1.0	—	+1.0	$\mu\text{A}$	
Output Leakage Current	$I_{LO}$	$V_{OUT} = V_{SS} \text{ to } V_{CC}, V_{CC} = V_{CC} \text{ Max}$	-1.0	—	+1.0	$\mu\text{A}$	
$A_9, \overline{OE}, \overline{RESET}$ Inputs Leakage Current	$I_{LIT}$	$V_{CC} = V_{CC} \text{ Max},$ $A_9, \overline{OE}, \overline{RESET} = 12.5 \text{ V}$	—	—	+35	$\mu\text{A}$	
$\overline{WP}/\text{ACC}$ Accelerated Program Current	$I_{LIA}$	$V_{CC} = V_{CC} \text{ Max},$ $\overline{WP}/\text{ACC} = V_{ACC} \text{ Max}$	—	—	20	mA	
$V_{CC}$ Active Current *1	$I_{CC1}$	$\overline{CE} = V_{IL}, \overline{OE} = V_{IH},$ $f = 5 \text{ MHz}$	Byte	—	—	16	mA
			Word	—	—	18	
		$\overline{CE} = V_{IL}, \overline{OE} = V_{IH},$ $f = 1 \text{ MHz}$	Byte	—	—	4	mA
			Word	—	—	4	
$V_{CC}$ Active Current *2	$I_{CC2}$	$\overline{CE} = V_{IL}, \overline{OE} = V_{IH}$	—	—	30	mA	
$V_{CC}$ Current (Standby)	$I_{CC3}$	$V_{CC} = V_{CC} \text{ Max}, \overline{CE} = V_{CC} \pm 0.3 \text{ V},$ $\overline{RESET} = V_{CC} \pm 0.3 \text{ V},$ $\overline{WP}/\text{ACC} = V_{CC} \pm 0.3 \text{ V}$	—	1	5	$\mu\text{A}$	
$V_{CC}$ Current (Standby, Reset)	$I_{CC4}$	$V_{CC} = V_{CC} \text{ Max},$ $\overline{RESET} = V_{SS} \pm 0.3 \text{ V}$	—	1	5	$\mu\text{A}$	
$V_{CC}$ Current (Automatic Sleep Mode) *5	$I_{CC5}$	$V_{CC} = V_{CC} \text{ Max}, \overline{CE} = V_{SS} \pm 0.3 \text{ V},$ $\overline{RESET} = V_{CC} \pm 0.3 \text{ V}$ $V_{IN} = V_{CC} \pm 0.3 \text{ V} \text{ or } V_{SS} \pm 0.3 \text{ V}$	—	1	5	$\mu\text{A}$	
$V_{CC}$ Active Current *6 (Read-While-Program)	$I_{CC6}$	$\overline{CE} = V_{IL}, \overline{OE} = V_{IH}$	Byte	—	—	46	mA
			Word	—	—	48	
$V_{CC}$ Active Current *6 (Read-While-Erase)	$I_{CC7}$	$\overline{CE} = V_{IL}, \overline{OE} = V_{IH}$	Byte	—	—	46	mA
			Word	—	—	48	
$V_{CC}$ Active Current (Erase-Suspend-Program)	$I_{CC8}$	$\overline{CE} = V_{IL}, \overline{OE} = V_{IH}$	—	—	40	mA	
Input Low Level	$V_{IL}$	—	-0.5	—	0.6	V	
Input High Level	$V_{IH}$	—	2.0	—	$V_{CC} + 0.3$	V	
Voltage for Autoselect and Sector Protection ( $A_9, \overline{OE}, \overline{RESET}$ ) *3,*4	$V_{ID}$	—	11.5	12	12.5	V	
Voltage for $\overline{WP}/\text{ACC}$ Sector Protection/Unprotection and Program Acceleration *4	$V_{ACC}$	—	8.5	9.0	9.5	V	
Output Low Voltage Level	$V_{OL}$	$I_{OL} = 4 \text{ mA}, V_{CC} = V_{CC} \text{ Min}$	—	—	0.45	V	
Output High Voltage Level	$V_{OH1}$	$I_{OH} = -2.0 \text{ mA}, V_{CC} = V_{CC} \text{ Min}$	2.4	—	—	V	
	$V_{OH2}$	$I_{OH} = -100 \mu\text{A}$	$V_{CC} - 0.4$	—	—	V	
Low $V_{CC}$ Lock-Out Voltage	$V_{LKO}$	—	2.3	2.4	2.5	V	

\*1 :  $I_{CC}$  current listed includes both the DC operating current and the frequency dependent component.

\*2 :  $I_{CC}$  active while Embedded Algorithm (program or erase) is in progress.

\*3 : This timing is only for Sector Group Protection Operation and Autoselect mode.

\*4 : Applicable for only  $V_{CC}$ .

\*5 : Automatic sleep mode enables the low power mode when addresses remain stable for 150 ns.

\*6 : Embedded Algorithm (program or erase) is in progress (@5 MHz.)



## ■ AC CHARACTERISTICS

### • Read Only Operations Characteristics

Parameter	Symbol		Condition	Value (Note)		Unit
	JEDEC	Standard		Min	Max	
Read Cycle Time	$t_{AVAV}$	$t_{RC}$	—	70	—	ns
Address to Output Delay	$t_{AVQV}$	$t_{ACC}$	$\overline{CE} = V_{IL}$ $\overline{OE} = V_{IL}$	—	70	ns
Chip Enable to Output Delay	$t_{ELQV}$	$t_{CE}$	$\overline{OE} = V_{IL}$	—	70	ns
Output Enable to Output Delay	$t_{GLQV}$	$t_{OE}$	—	—	30	ns
Chip Enable to Output High-Z	$t_{EHQZ}$	$t_{DF}$	—	—	25	ns
Output Enable to Output High-Z	$t_{GHQZ}$	$t_{DF}$	—	—	25	ns
Output Hold Time From Addresses, $\overline{CE}$ or $\overline{OE}$ , Whichever Occurs First	$t_{AXQX}$	$t_{OH}$	—	0	—	ns
$\overline{RESET}$ Pin Low to Read Mode	—	$t_{READY}$	—	—	20	$\mu s$
$\overline{CE}$ to $\overline{BYTE}$ Switching Low or High	—	$t_{ELFL}$ $t_{ELFH}$	—	—	5	ns

Note : Test Conditions :

Output Load : 30 pF (MBM29DL64DF-70)

Input rise and fall times : 5 ns

Input pulse levels : 0.0 V or  $V_{CC}$

Timing measurement reference level

Input :  $0.5 \times V_{CC}$

Output :  $0.5 \times V_{CC}$

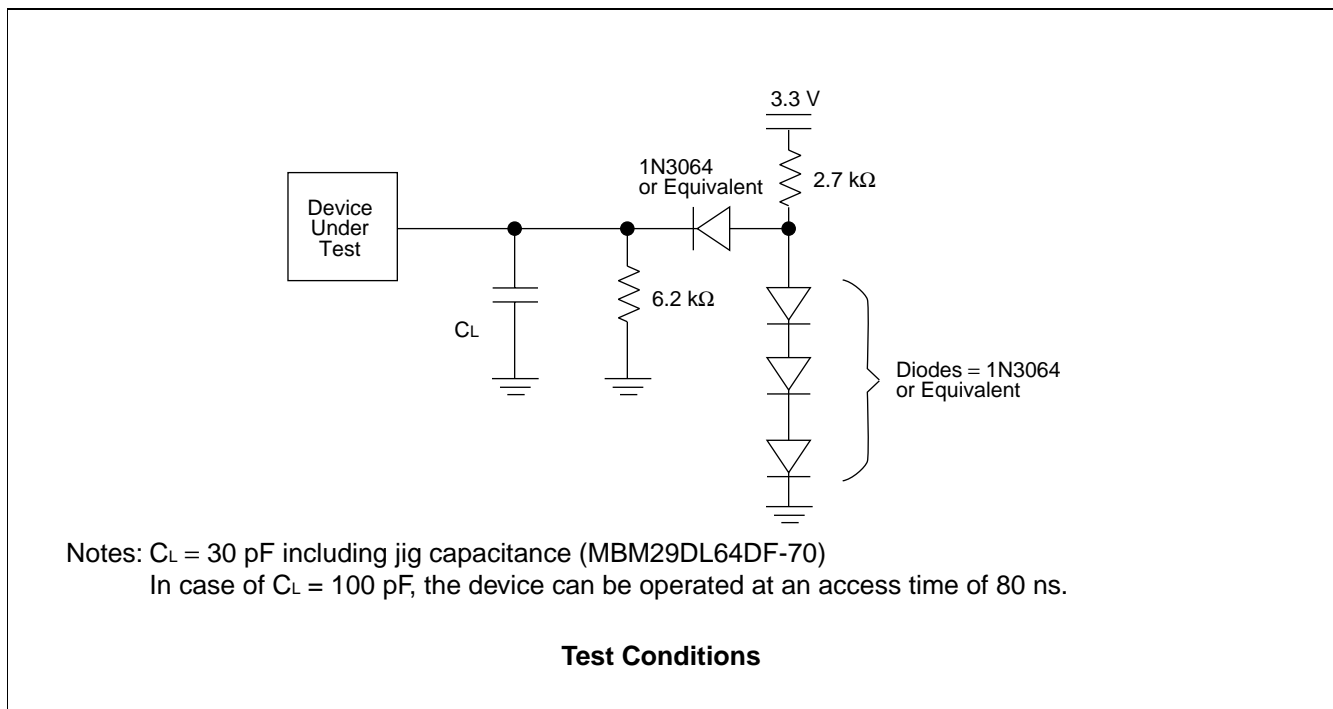

# MBM29DL64DF-70

## • Write/Erase/Program Operations

Parameter		Symbol		Value			Unit
		JEDEC	Standard	Min	Typ	Max	
Write Cycle Time		$t_{AVAV}$	$t_{WC}$	70	—	—	ns
Address Setup Time		$t_{AVWL}$	$t_{AS}$	0	—	—	ns
Address Setup Time to $\overline{OE}$ Low During Toggle Bit Polling		—	$t_{ASO}$	12	—	—	ns
Address Hold Time		$t_{WLAX}$	$t_{AH}$	30	—	—	ns
Address Hold Time from $\overline{CE}$ or $\overline{OE}$ High During Toggle Bit Polling		—	$t_{AHT}$	0	—	—	ns
Data Setup Time		$t_{DVWH}$	$t_{DS}$	25	—	—	ns
Data Hold Time		$t_{WHDX}$	$t_{DH}$	0	—	—	ns
Output Enable Hold Time	Read	—	$t_{OEHL}$	0	—	—	ns
	Toggle and $\overline{Data}$ Polling			10	—	—	ns
$\overline{CE}$ High During Toggle Bit Polling		—	$t_{CEPH}$	20	—	—	ns
$\overline{OE}$ High During Toggle Bit Polling		—	$t_{OEPH}$	20	—	—	ns
Read Recover Time Before Write		$t_{GHWL}$	$t_{GHWL}$	0	—	—	ns
Read Recover Time Before Write		$t_{GHEL}$	$t_{GHEL}$	0	—	—	ns
$\overline{CE}$ Setup Time		$t_{ELWL}$	$t_{CS}$	0	—	—	ns
$\overline{WE}$ Setup Time		$t_{WLEL}$	$t_{WS}$	0	—	—	ns
$\overline{CE}$ Hold Time		$t_{WHEH}$	$t_{CH}$	0	—	—	ns
$\overline{WE}$ Hold Time		$t_{EHWH}$	$t_{WH}$	0	—	—	ns
Write Pulse Width		$t_{WLWH}$	$t_{WP}$	35	—	—	ns
$\overline{CE}$ Pulse Width		$t_{ELEH}$	$t_{CP}$	35	—	—	ns
Write Pulse Width High		$t_{WHWL}$	$t_{WPH}$	20	—	—	ns
$\overline{CE}$ Pulse Width High		$t_{EHEL}$	$t_{CPH}$	20	—	—	ns
Programming Operation	Byte	$t_{WHWH1}$	$t_{WHWH1}$	—	4	—	$\mu$ s
	Word			—	6	—	$\mu$ s
Sector Erase Operation *1		$t_{WHWH2}$	$t_{WHWH2}$	—	0.5	—	s
$V_{CC}$ Setup Time		—	$t_{VCS}$	50	—	—	$\mu$ s
Rise Time to $V_{ID}$ *2		—	$t_{VIDR}$	500	—	—	ns
Rise Time to $V_{ACC}$ *3		—	$t_{VACCR}$	500	—	—	ns
Voltage Transition Time *2		—	$t_{VLHT}$	4	—	—	$\mu$ s
Write Pulse Width *2		—	$t_{WPP}$	100	—	—	$\mu$ s

(Continued)

(Continued)

Parameter	Symbol		Value			Unit
	JEDEC	Standard	Min	Typ	Max	
$\overline{OE}$ Setup Time to $\overline{WE}$ Active *2	—	tOESP	4	—	—	μs
$\overline{CE}$ Setup Time to $\overline{WE}$ Active *2	—	tCSP	4	—	—	μs
Recover Time from RY/ $\overline{BY}$	—	tRB	0	—	—	ns
$\overline{RESET}$ Pulse Width	—	tRP	500	—	—	ns
$\overline{RESET}$ High Level Period Before Read	—	tRH	200	—	—	ns
$\overline{BYTE}$ Switching Low to Output High-Z	—	tFLQZ	—	—	25	ns
$\overline{BYTE}$ Switching High to Output Active	—	tFHQV	—	—	70	ns
Program/Erase Valid to RY/ $\overline{BY}$ Delay	—	tBUSY	—	—	90	ns
Delay Time from Embedded Output Enable	—	tEOE	—	—	70	ns
Erase Time-out Time	—	tTOW	50	—	—	μs
Erase Suspend Transition Time	—	tSPD	—	—	20	μs

\*1 : Does not include preprogramming time.

\*2 : For Sector Group Protection operation.

\*3 : For Accelerated Program operation only.

# MBM29DL64DF-70

## ■ ERASE AND PROGRAMMING PERFORMANCE

Parameter	Limits			Unit	Comments
	Min	Typ	Max		
Sector Erase Time	—	0.5	2.0	s	Excludes programming time prior to erasure
Word Programming Time	—	6.0	100	μs	Excludes system-level overhead
Byte Programming Time	—	4.0	80	μs	
Chip Programming Time	—	—	200	s	Excludes system-level overhead
Program/Erase Cycle	100,000	—	—	cycle	—

Notes : Typical Erase conditions  $T_A = +25\text{ }^\circ\text{C}$ ,  $V_{CC} = 2.9\text{ V}$   
 Typical Program conditions  $T_A = +25\text{ }^\circ\text{C}$ ,  $V_{CC} = 2.9\text{ V}$ , Data = Checker

## ■ TSOP (1) PIN CAPACITANCE

Parameter	Symbol	Condition	Value		Unit
			Typ	Max	
Input Capacitance	$C_{IN}$	$V_{IN} = 0$	6.0	10.0	pF
Output Capacitance	$C_{OUT}$	$V_{OUT} = 0$	8.5	12.0	pF
Control Pin Capacitance	$C_{IN2}$	$V_{IN} = 0$	8.0	11.0	pF
$\overline{WP}/ACC$ Pin Capacitance	$C_{IN3}$	$V_{IN} = 0$	9.0	12.0	pF

Notes : • Test conditions  $T_A = +25\text{ }^\circ\text{C}$ ,  $f = 1.0\text{ MHz}$   
 •  $DQ_{15}/A-1$  pin capacitance is stipulated by output capacitance.

## ■ FBGA PIN CAPACITANCE

Parameter	Symbol	Condition	Value		Unit
			Typ	Max	
Input Capacitance	$C_{IN}$	$V_{IN} = 0$	6.0	10.0	pF
Output Capacitance	$C_{OUT}$	$V_{OUT} = 0$	8.5	12.0	pF
Control Pin Capacitance	$C_{IN2}$	$V_{IN} = 0$	8.0	11.0	pF
$\overline{WP}/ACC$ Pin Capacitance	$C_{IN3}$	$V_{IN} = 0$	9.0	12.0	pF

Notes : • Test conditions  $T_A = +25\text{ }^\circ\text{C}$ ,  $f = 1.0\text{ MHz}$   
 •  $DQ_{15}/A-1$  pin capacitance is stipulated by output capacitance.

## ■ TIMING DIAGRAM

### • Key to Switching Waveforms

WAVEFORM	INPUTS	OUTPUTS
	Must Be Steady	Will Be Steady
	May Change from H to L	Will Change from H to L
	May Change from L to H	Will Change from L to H
	"H" or "L": Any Change Permitted	Changing, State Unknown
	Does Not Apply	Center Line is High-Impedance "Off" State

### (1) Read Operation Timing Diagram

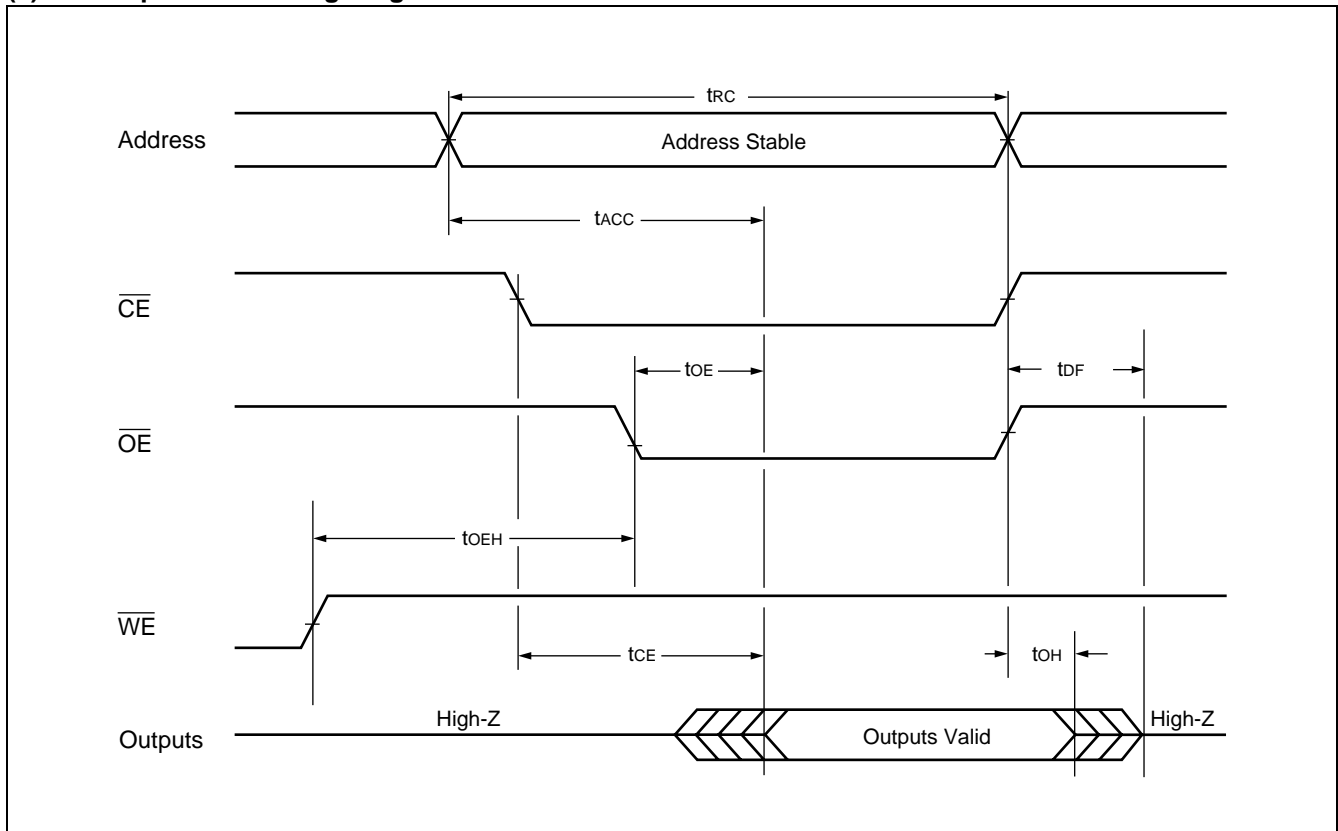

# MBM29DL64DF-70

## (2) Hardware Reset/Read Operation Timing Diagram

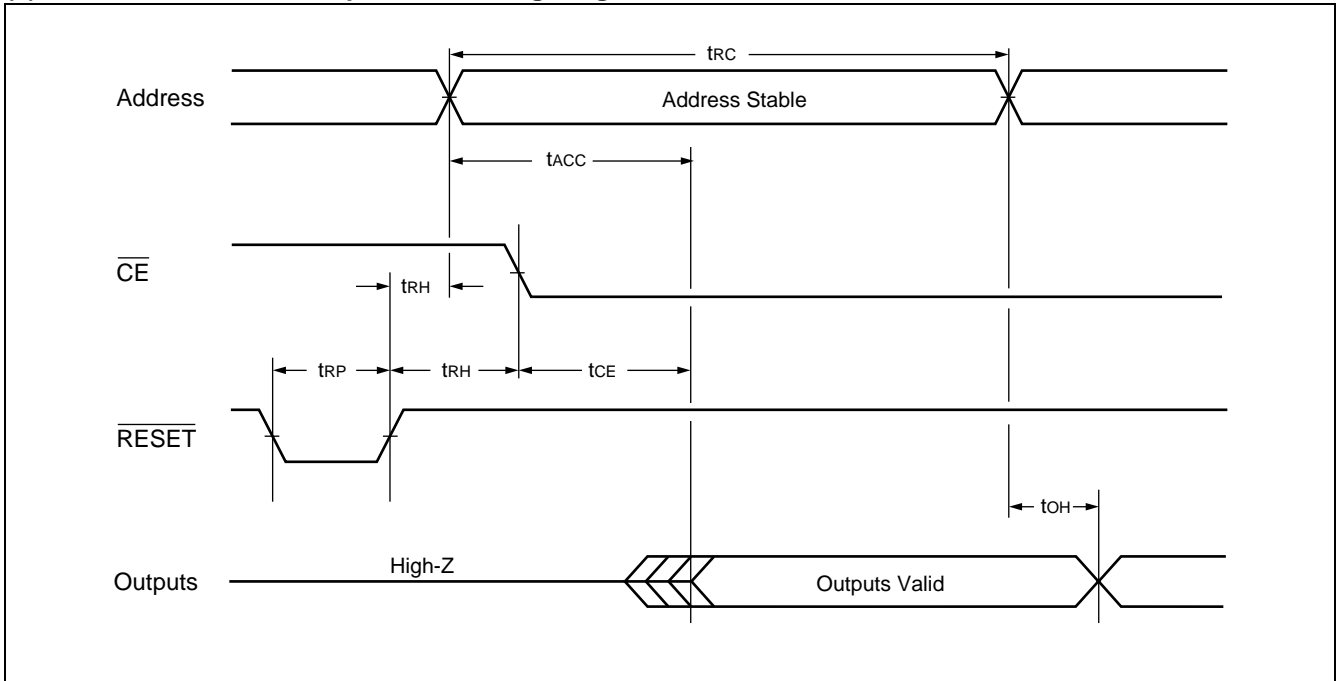

## (3) Alternate $\overline{WE}$ Controlled Program Operation Timing Diagram

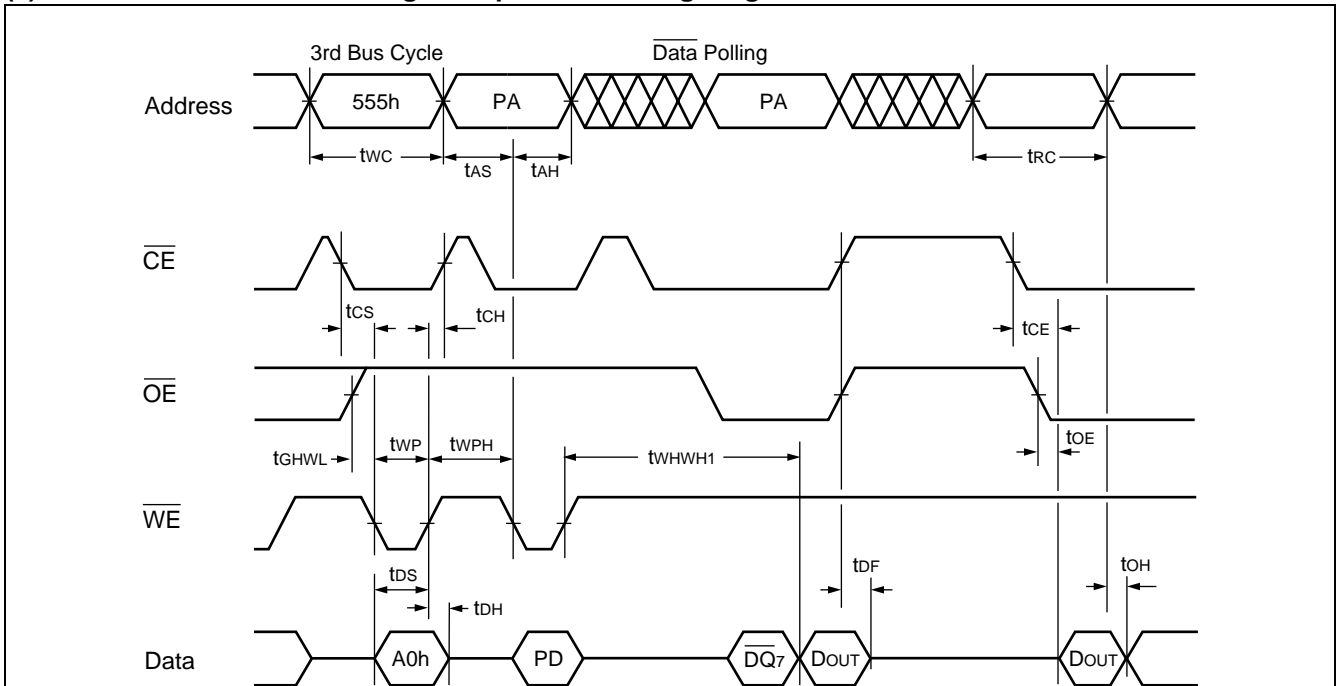

- Notes:
- PA is address of the memory location to be programmed.
  - $\overline{PD}$  is data to be programmed at word address.
  - $\overline{DQ}_7$  is the output of the complement of the data written to the device.
  - $D_{OUT}$  is the output of the data written to the device.
  - Figure indicates the last two bus cycles out of four bus cycle sequence.
  - These waveforms are for the  $\times 16$  mode.

## (4) Alternate $\overline{CE}$ Controlled Program Operation Timing Diagram

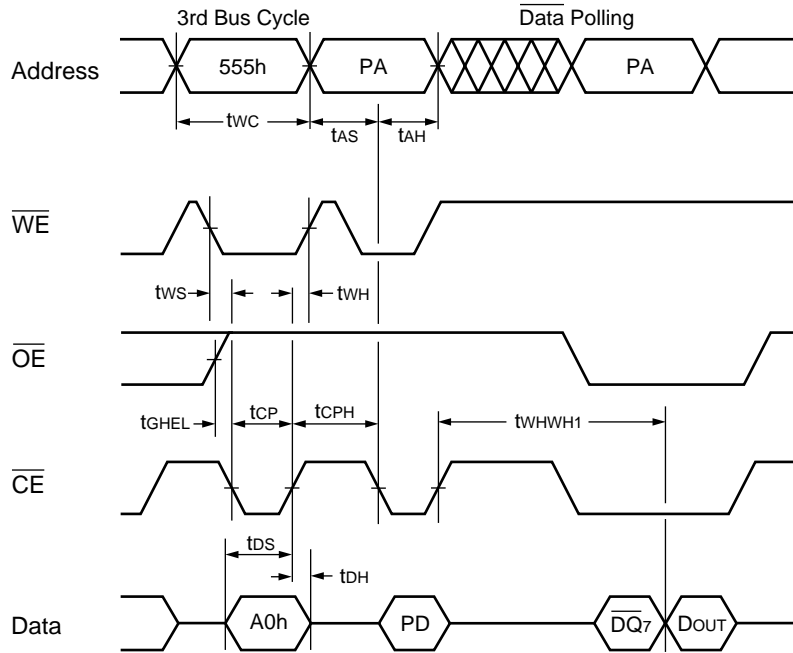

- Notes:
- PA is address of the memory location to be programmed.
  - PD is data to be programmed at word address.
  - $\overline{DQ}_7$  is the output of the complement of the data written to the device.
  - D<sub>OUT</sub> is the output of the data written to the device.
  - Figure indicates the last two bus cycles out of four bus cycle sequence.
  - These waveforms are for the  $\times 16$  mode.

# MBM29DL64DF-70

## (5) Chip/Sector Erase Operation Timing Diagram

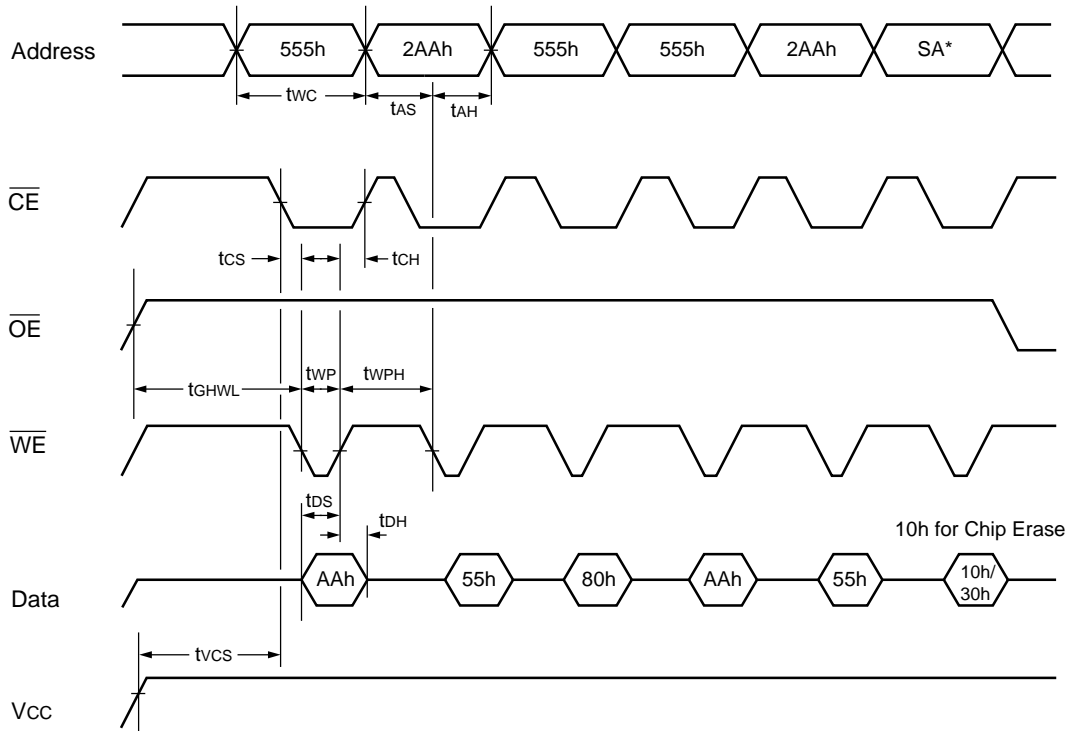

\* : SA is the sector address for Sector Erase. Addresses = 555h (Word) for Chip Erase.

Note : These waveforms are for the  $\times 16$  mode. The addresses differ from the  $\times 8$  mode.

## (6) Data Polling during Embedded Algorithm Operation Timing Diagram

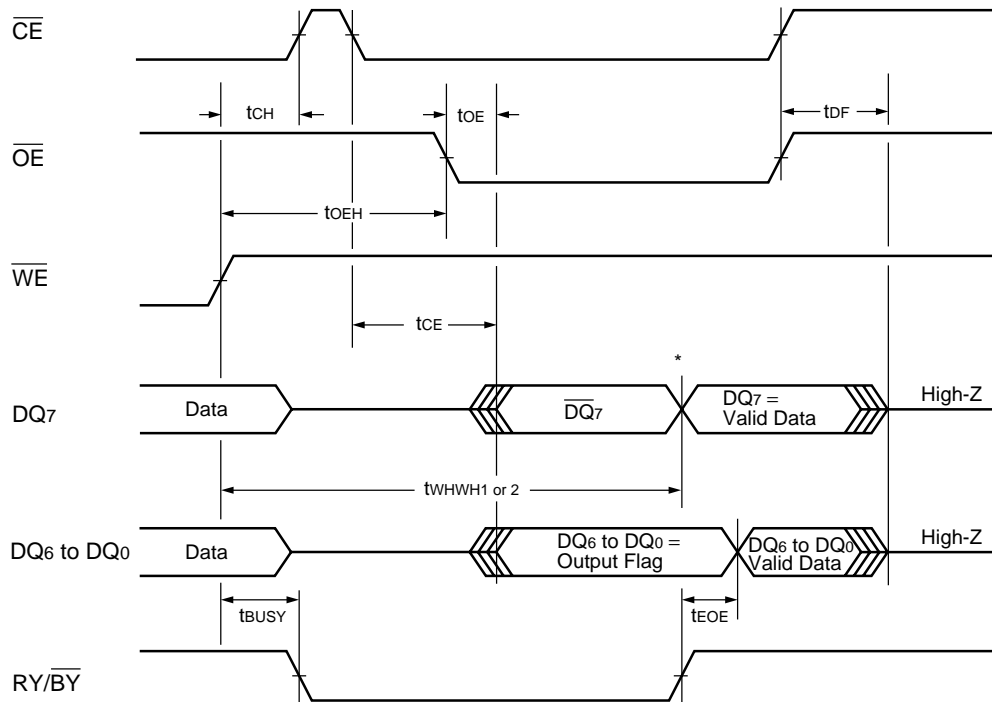

\* : DQ<sub>7</sub> = Valid Data (the device has completed the Embedded operation) .



## (7) AC Waveforms for Toggle Bit I during Embedded Algorithm Operations

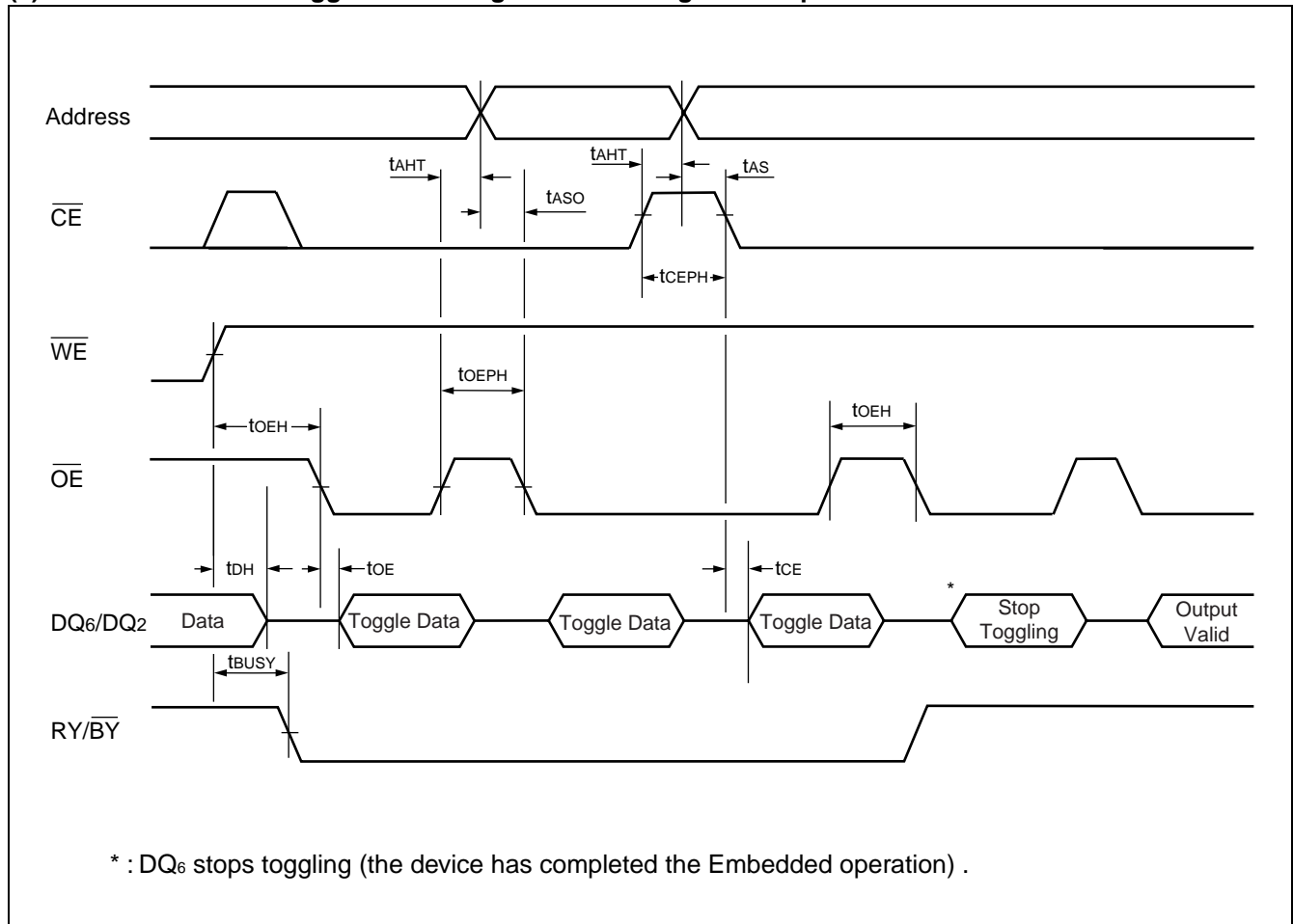

# MBM29DL64DF-70

## (8) Bank-to-Bank Read/Write Timing Diagram

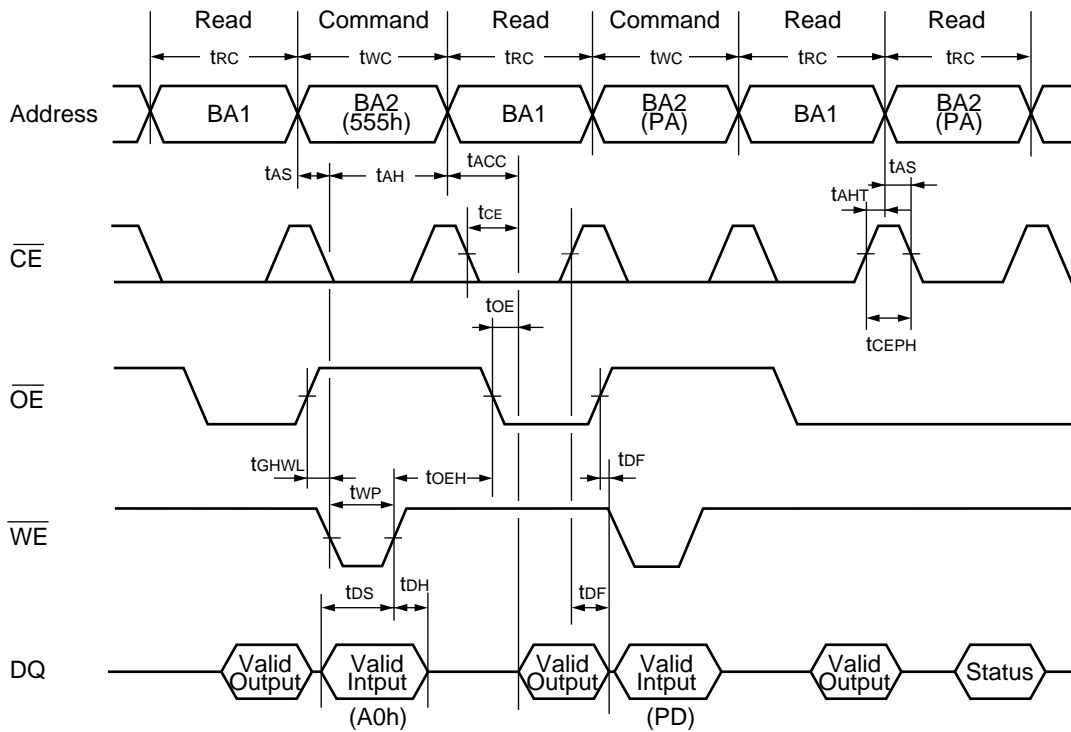

Note : This is example of Read for Bank 1 and Embedded Algorithm (program) for Bank 2.  
 BA1 : Address corresponding to Bank 1  
 BA2 : Address corresponding to Bank 2

## (9) DQ<sub>2</sub> vs. DQ<sub>6</sub>

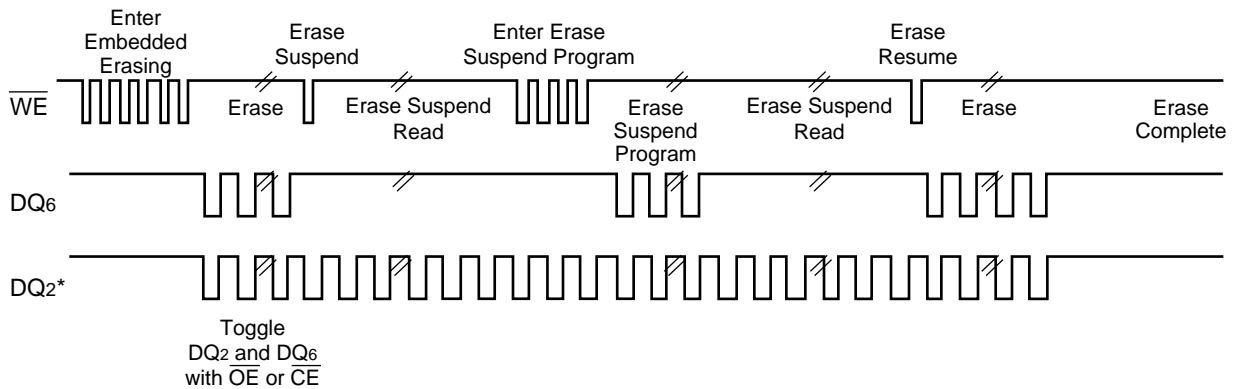

\* : DQ<sub>2</sub> is read from the erase-suspended sector.

**(10) RY/ $\overline{\text{BY}}$  Timing Diagram during Program/Erase Operation Timing Diagram**

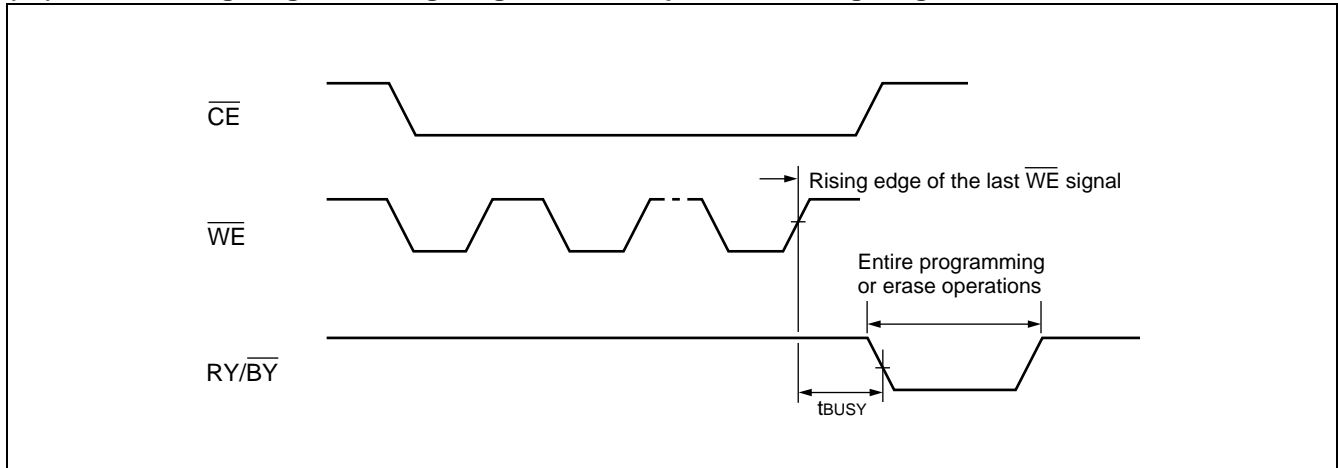

**(11)  $\overline{\text{RESET}}$ ,  $\text{RY}/\overline{\text{BY}}$  Timing Diagram**

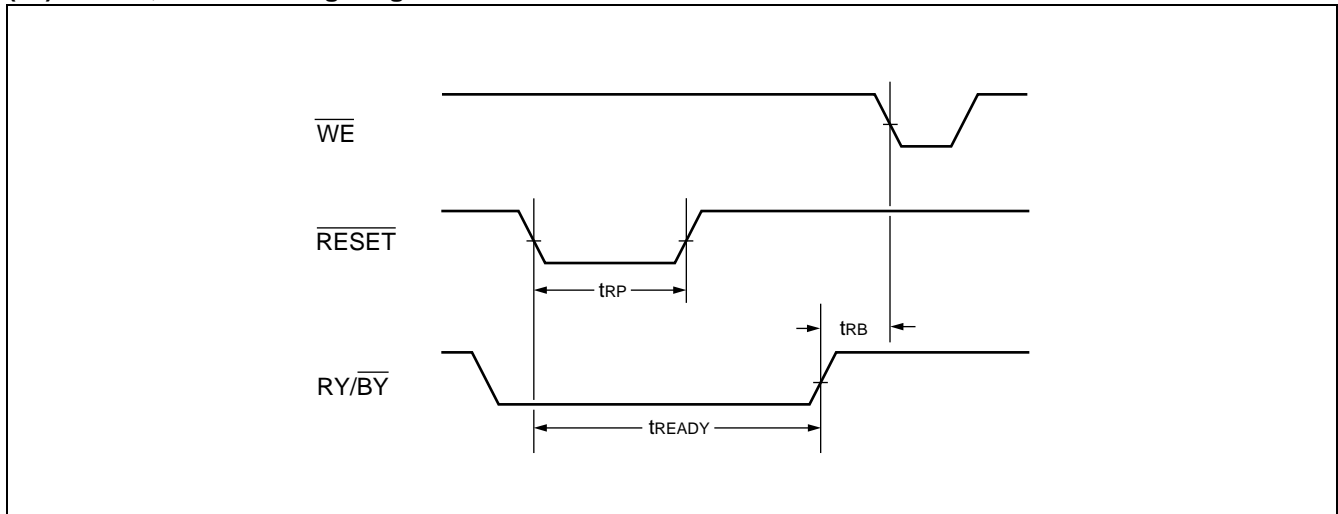

**(12) Timing Diagram for Word Mode Configuration**

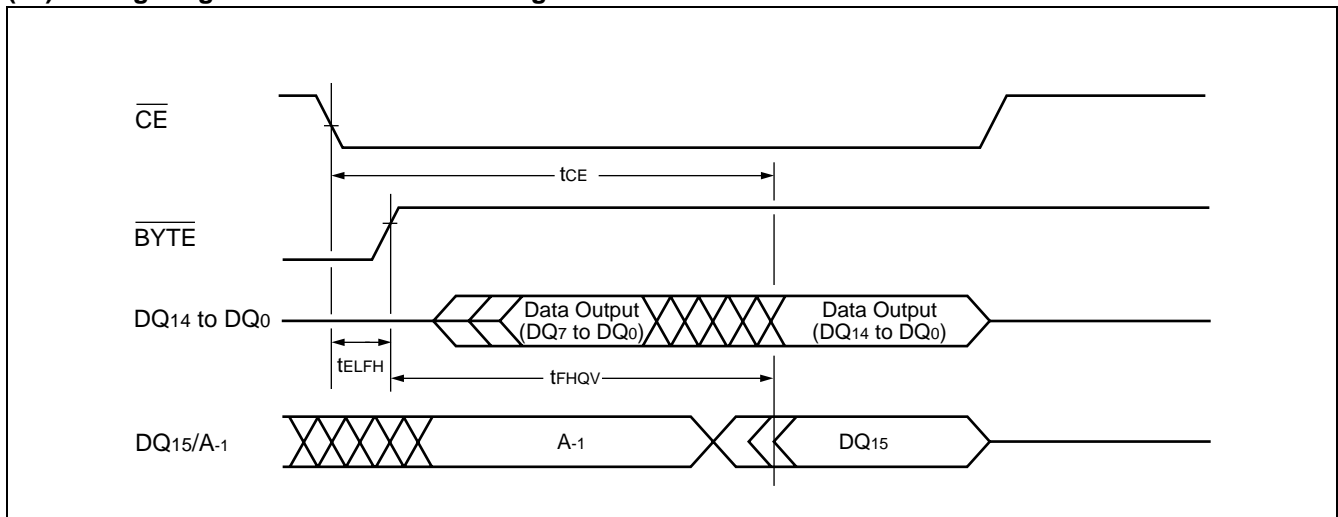

# MBM29DL64DF-70

(13) Timing Diagram for Byte Mode Configuration

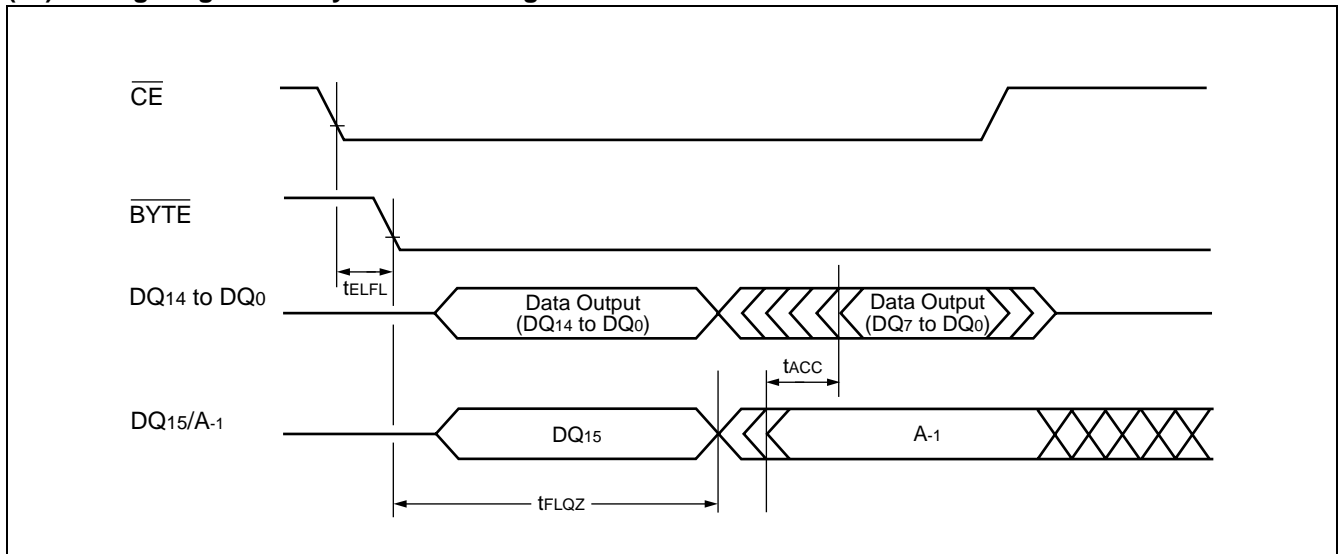

(14)  $\overline{BYTE}$  Timing Diagram for Write Operations

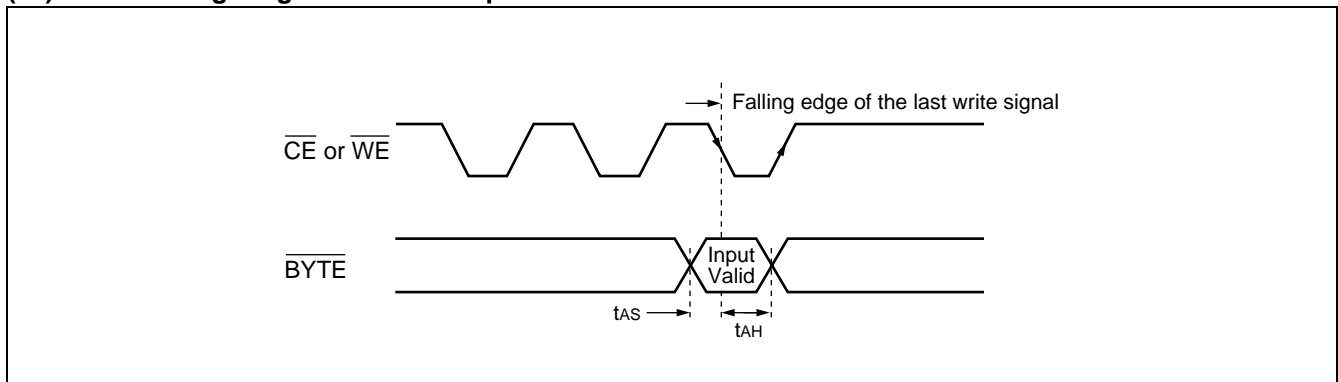

## (15) Sector Group Protection Timing Diagram

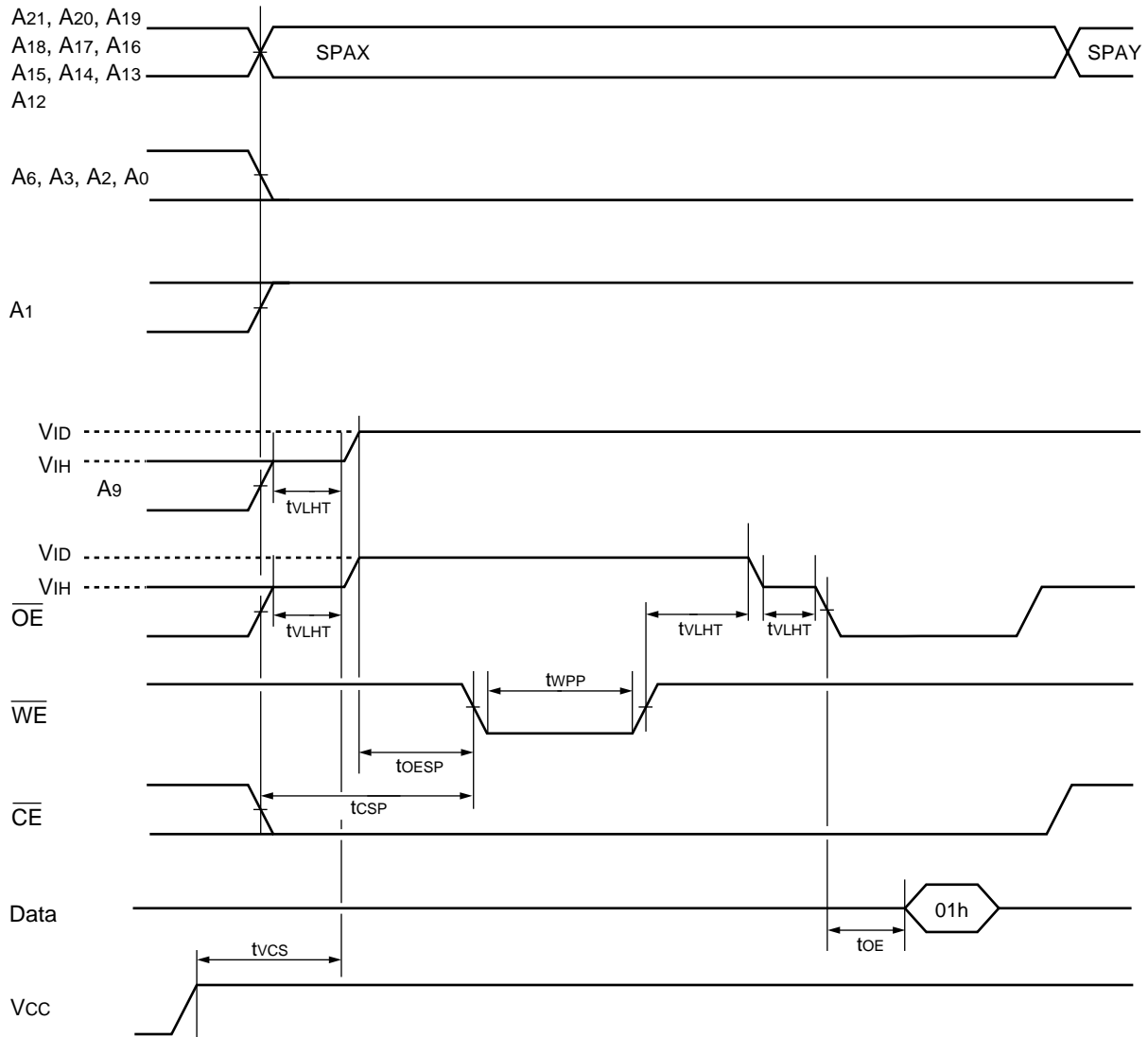

SPAX : Sector Group Address to be protected  
 SPAY : Next Sector Group Address to be protected

Note : A-1 is  $V_{\text{IL}}$  on byte mode.

# MBM29DL64DF-70

(16) Temporary Sector Group Unprotection Timing Diagram

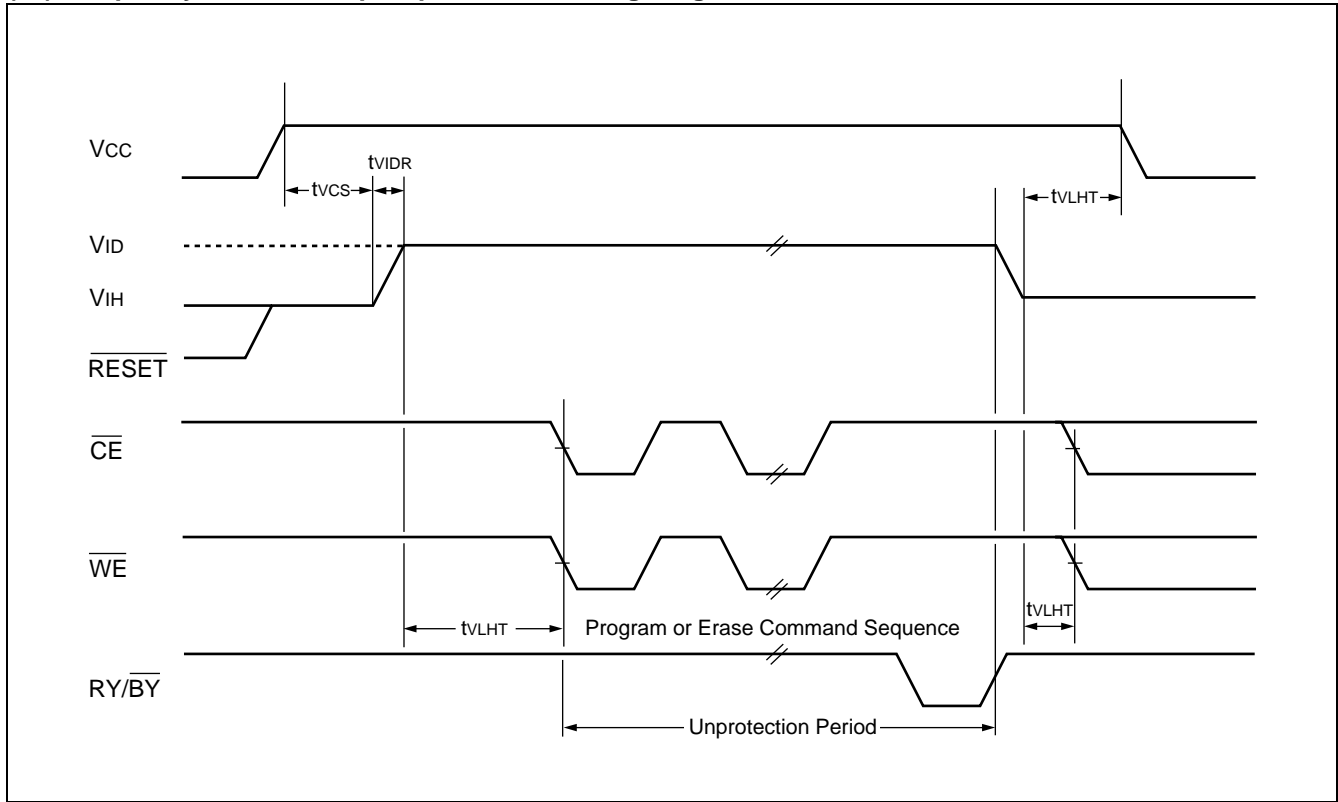

(17) Extended Sector Group Protection Timing Diagram

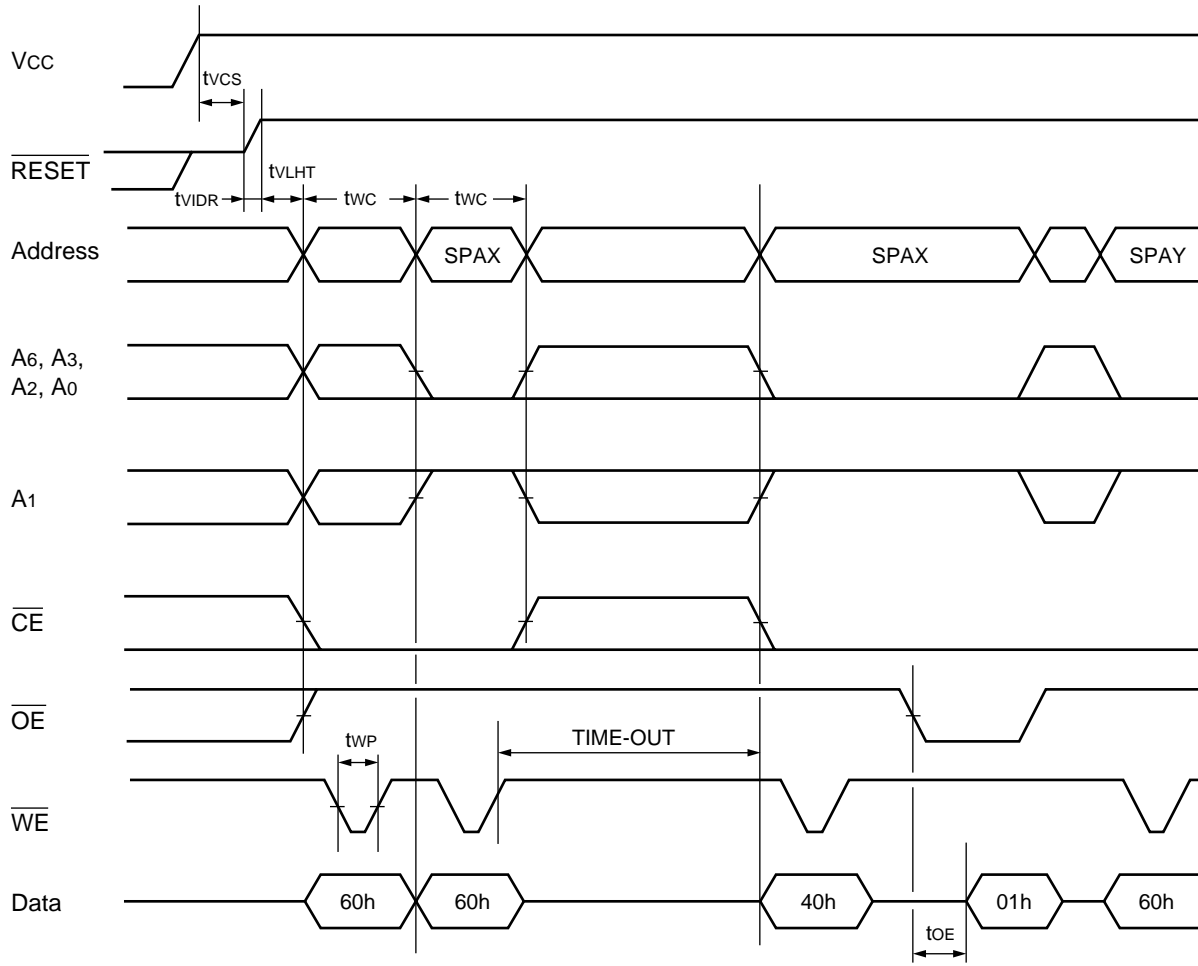

SPAX : Sector Group Address to be protected  
 SPAY : Next Sector Group Address to be protected  
 TIME-OUT : Time-Out window = 250 μs (Min)

# MBM29DL64DF-70

(18) Accelerated Program Timing Diagram

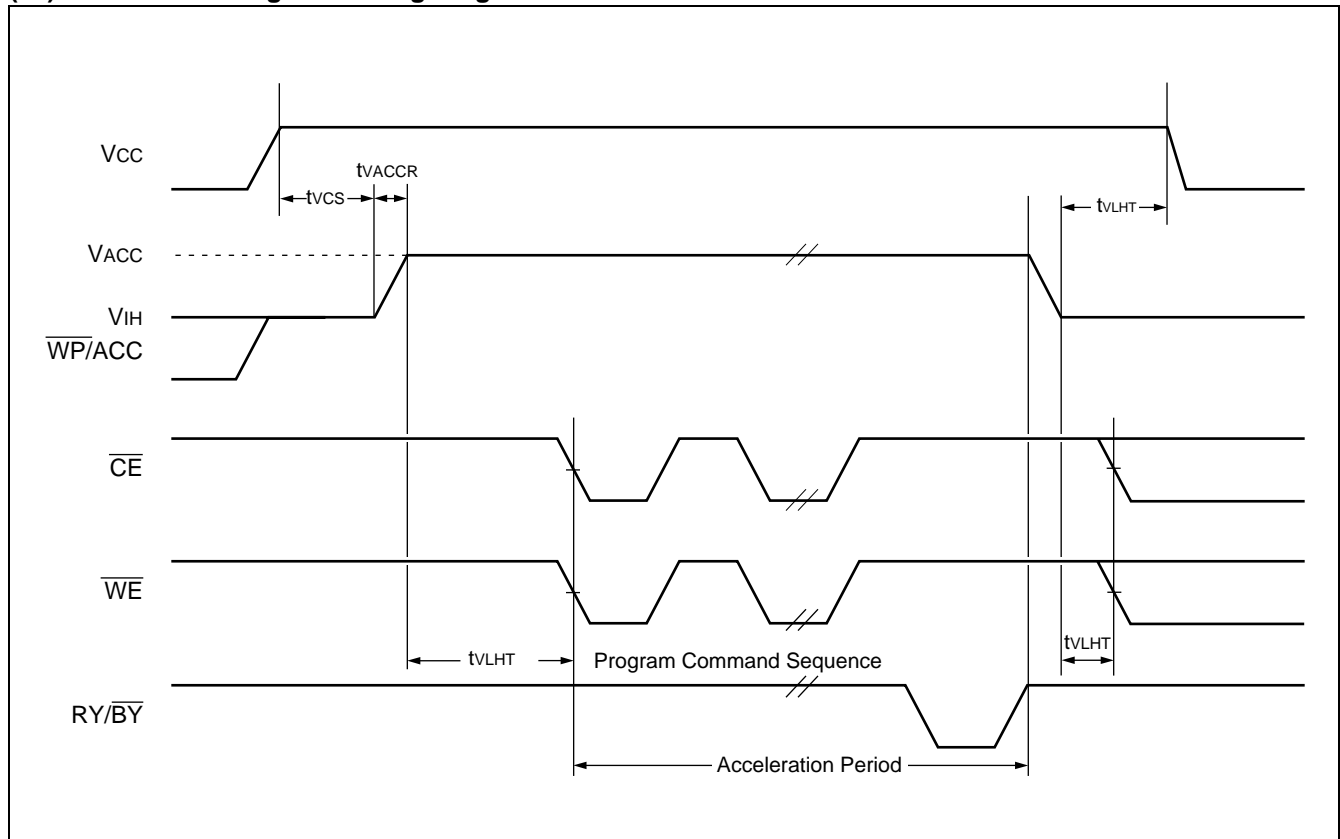



## ■ FLOW CHART

### (1) Embedded Program™ Algorithm

#### EMBEDDED ALGORITHM

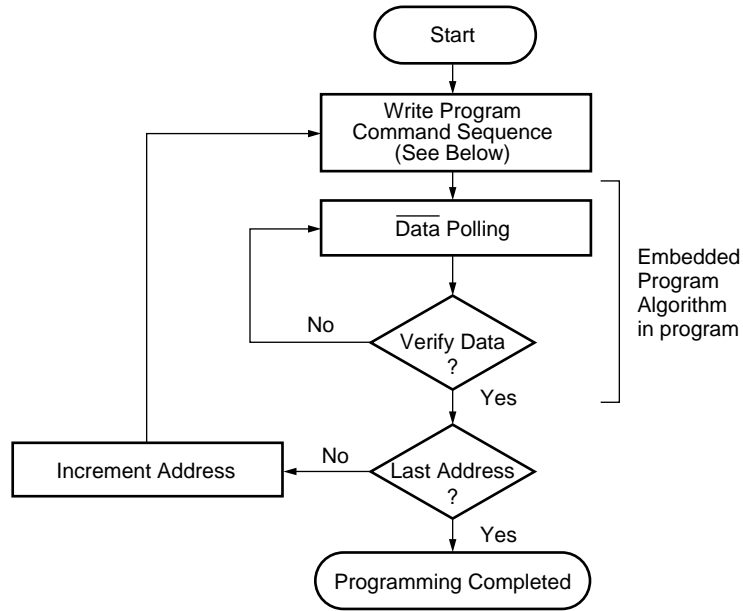

Program Command Sequence (Address/Command):

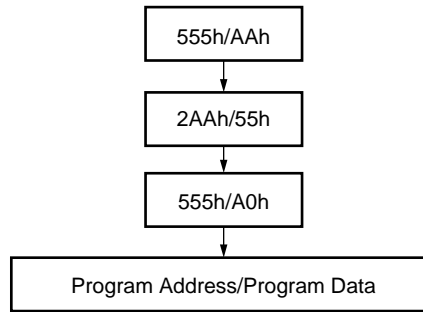

Note : The sequence is applied for × 16 mode.

## (2) Embedded Erase™ Algorithm

### EMBEDDED ALGORITHM

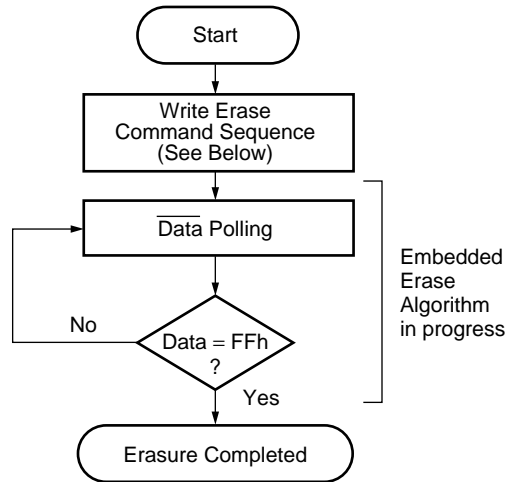

Chip Erase Command Sequence  
(Address/Command):

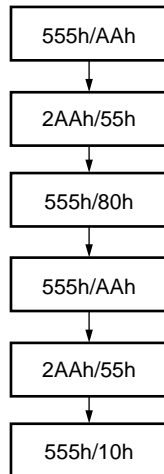

Individual Sector/Multiple Sector  
Erase Command Sequence  
(Address/Command):

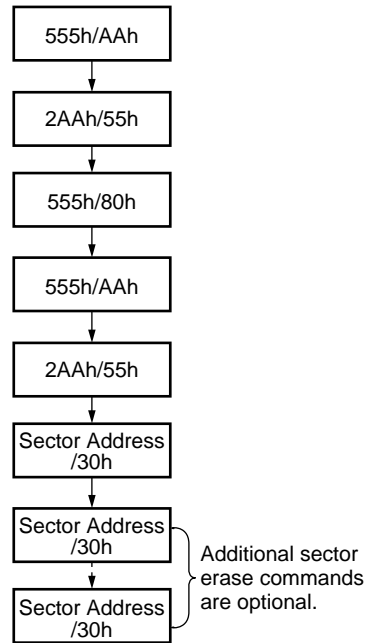

Note : The sequence is applied for × 16 mode.

## (3) Data Polling Algorithm

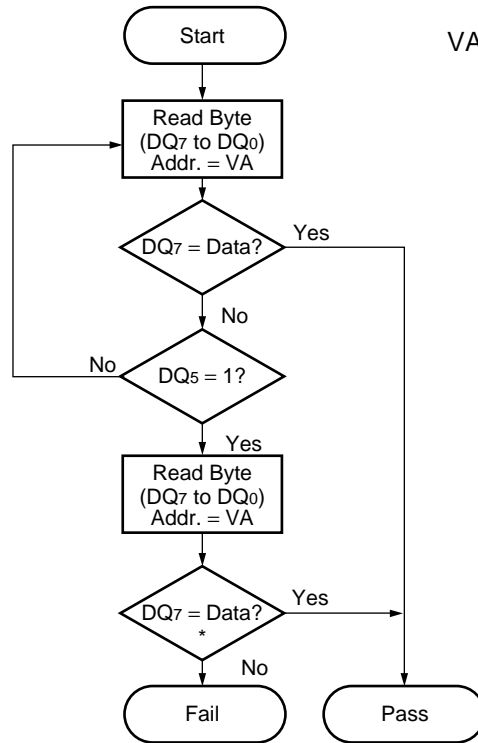

VA = Address for programming  
 = Any of the sector addresses within the sector being erased during sector erase or multiple sector erases operation.  
 = Any of the sector addresses within the sector not being protected during chip erase operation.

\* : DQ<sub>7</sub> is rechecked even if DQ<sub>5</sub> = "1" because DQ<sub>7</sub> may change simultaneously with DQ<sub>5</sub>.

## (4) Toggle Bit Algorithm

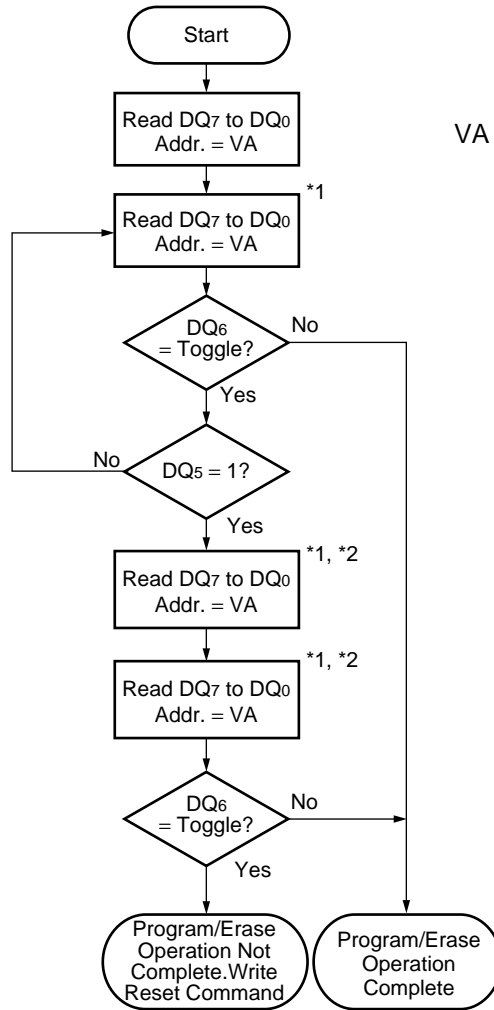

VA = Bank address being executed Embedded Algorithm.

\*1 : Read toggle bit twice to determine whether it is toggling.

\*2 : Recheck toggle bit because it may stop toggling as DQ5 changes to "1".

## (5) Sector Group Protection Algorithm

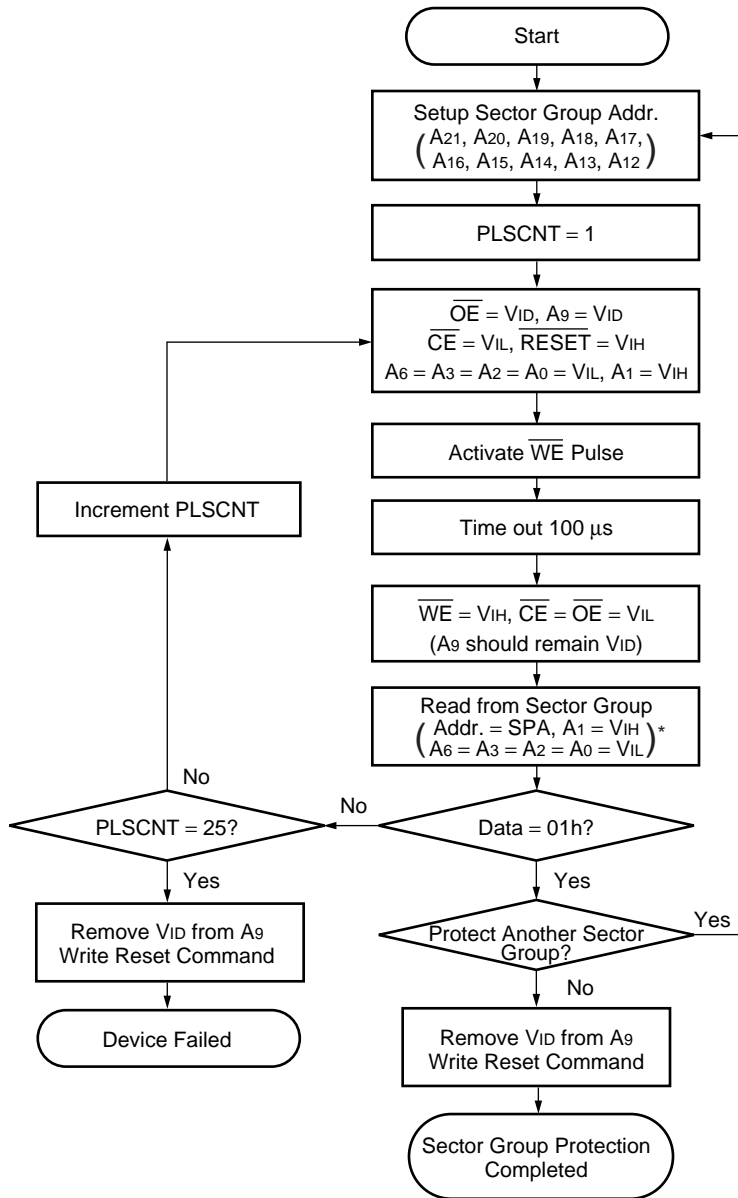

\* : A-1 is V<sub>IL</sub> in byte mode.

## (6) Temporary Sector Group Unprotection Algorithm

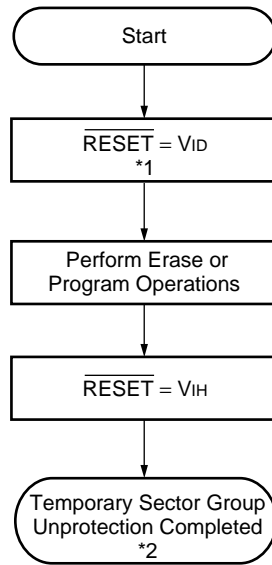

\*1 : All protected sector groups are unprotected.

\*2 : All previously protected sector groups are reprotected.

## (7) Extended Sector Group Protection Algorithm

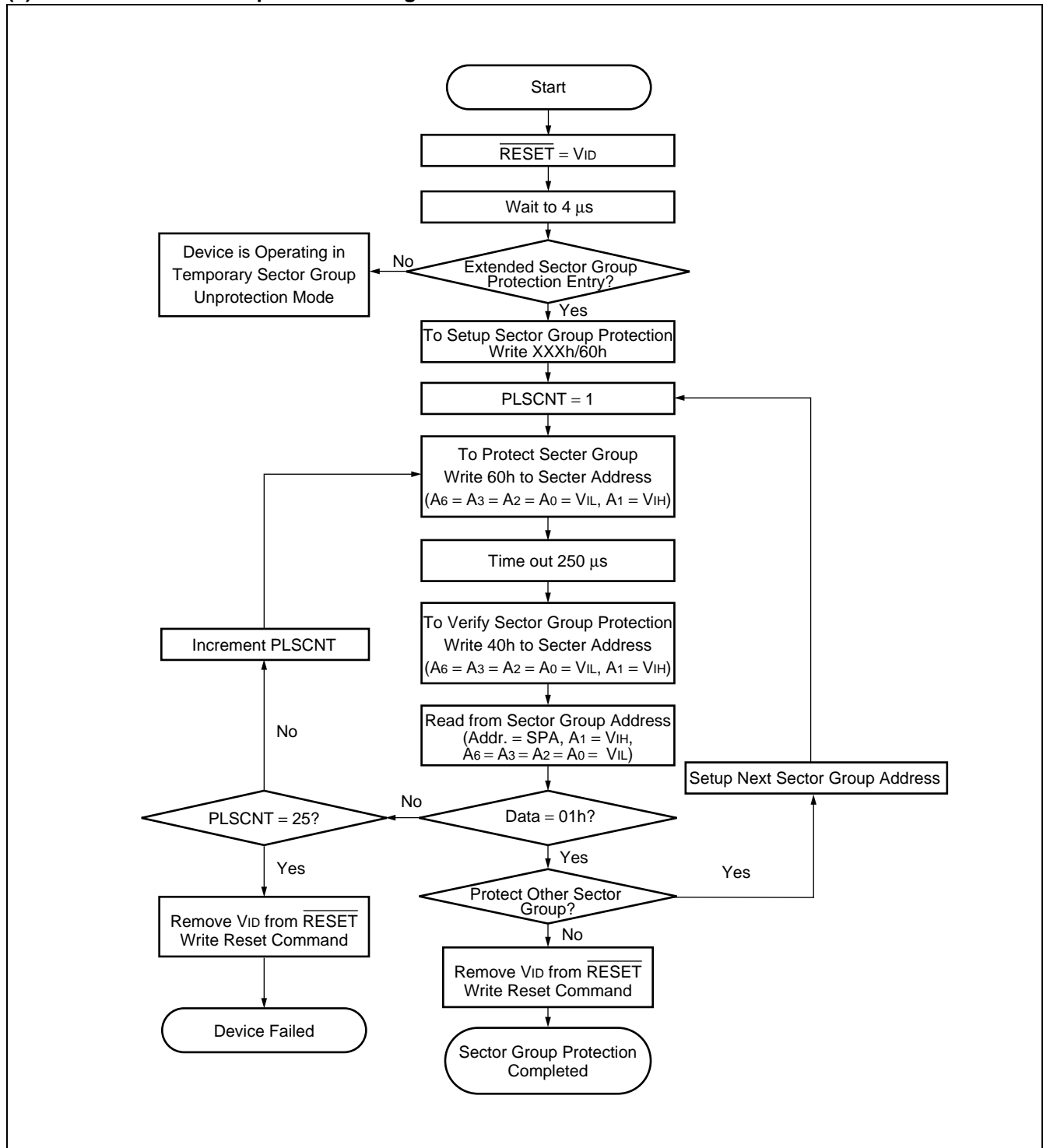

## (8) Embedded Programming Algorithm for Fast Mode

### FAST MODE ALGORITHM

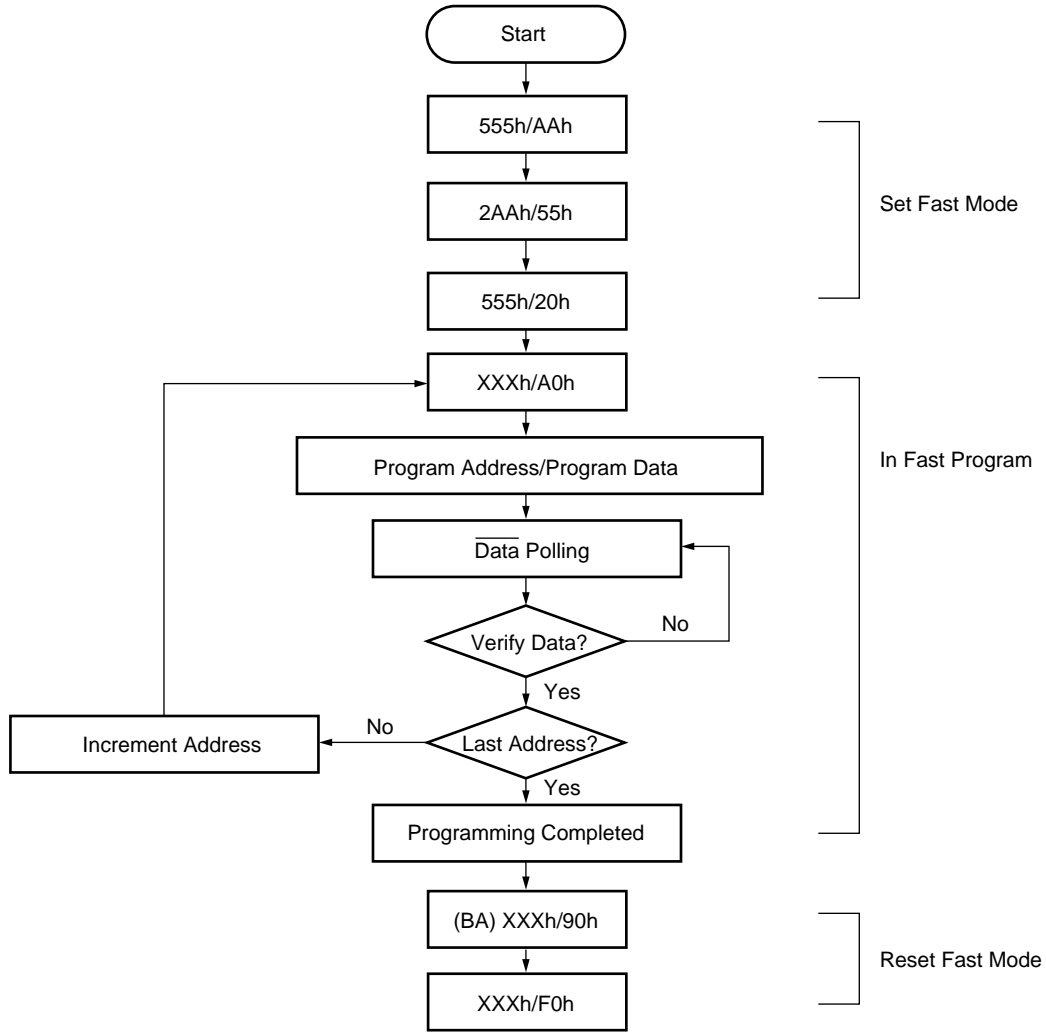

Note : The sequence is applied for × 16 mode.



## ■ ORDERING INFORMATION

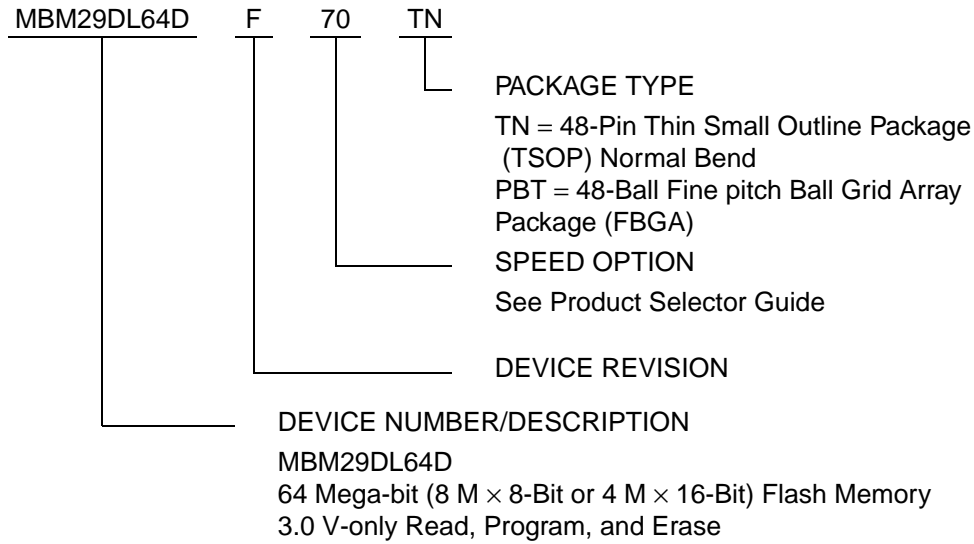

Part No.	Package	Access Time (ns)	Remarks
MBM29DL64DF70TN	48-pin plastic TSOP (1) (FPT-48P-M19) Normal Bend	70	
MBM29DL64DF70PBT	48-pin plastic FBGA (BGA-48P-M13)	70	

# MBM29DL64DF-70

## PACKAGE DIMENSIONS

48-pin plastic TSOP (1)  
(FPT-48P-M19)

Note 1) \* : Values do not include resin protrusion.

Resin protrusion and gate protrusion are +0.15 (.006) Max (each side) .

Note 2) Pins width and pins thickness include plating thickness.

Note 3) Pins width do not include tie bar cutting remainder.

LEAD No.

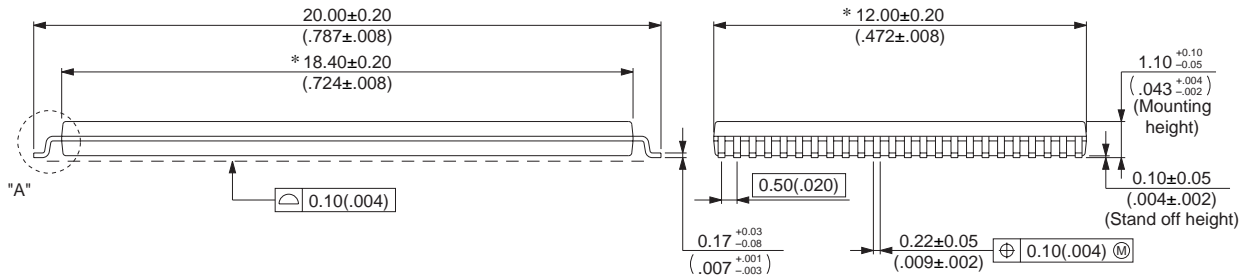
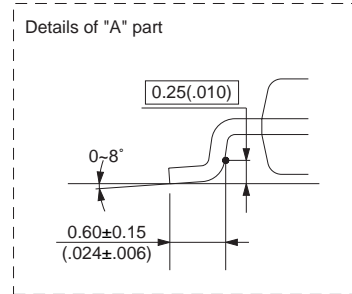
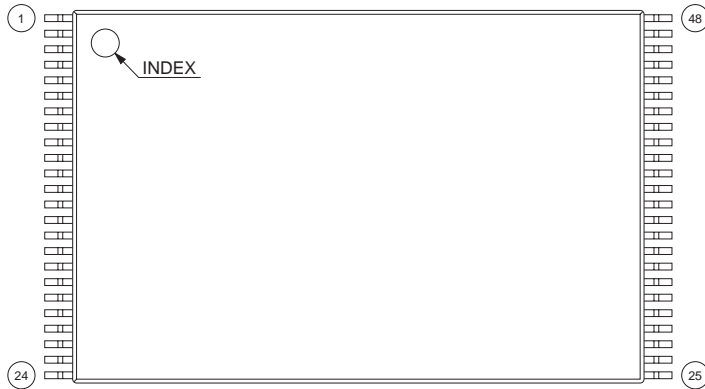

© 2003 FUJITSU LIMITED F48029S-c-6-7

Dimensions in mm (inches)

Note : The values in parentheses are reference values.

(Continued)

(Continued)

48-pin plastic FBGA  
(BGA-48P-M13)

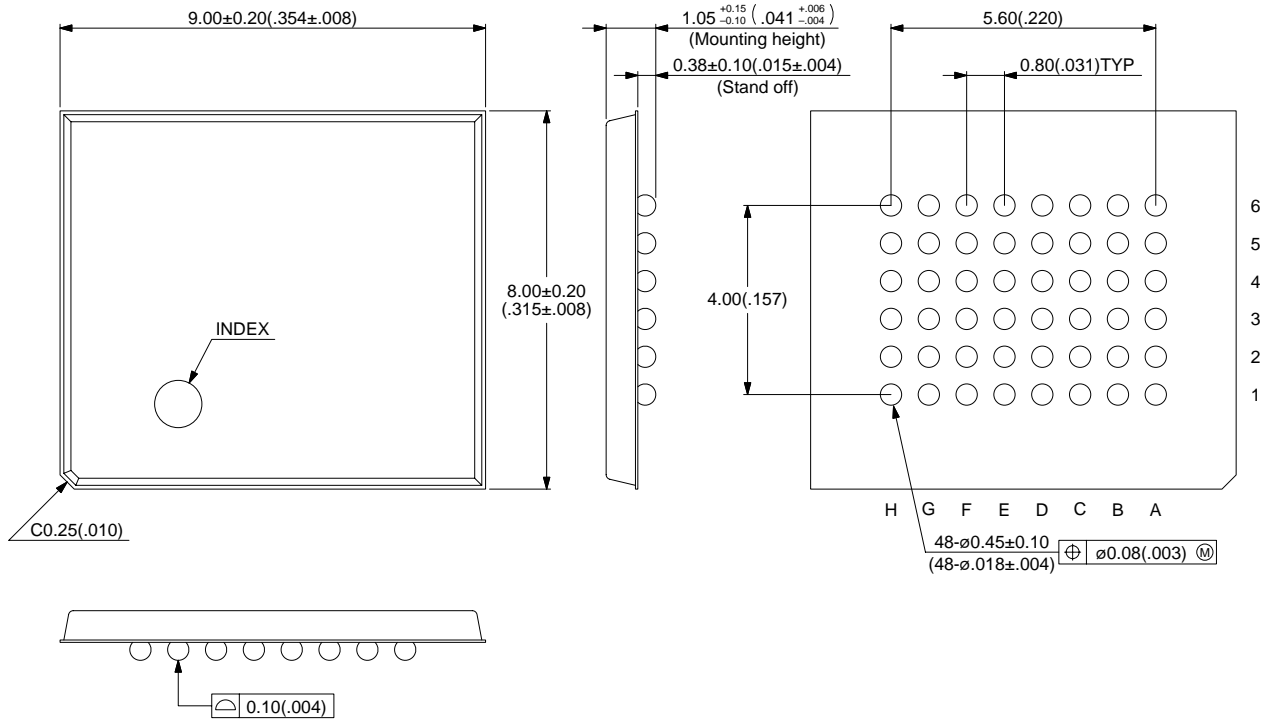

© 2001 FUJITSU LIMITED B48013S-c-3-2

Dimensions in mm (inches)

Note : The values in parentheses are reference values.

## FUJITSU LIMITED

All Rights Reserved.

The contents of this document are subject to change without notice. Customers are advised to consult with FUJITSU sales representatives before ordering.

The information, such as descriptions of function and application circuit examples, in this document are presented solely for the purpose of reference to show examples of operations and uses of Fujitsu semiconductor device; Fujitsu does not warrant proper operation of the device with respect to use based on such information. When you develop equipment incorporating the device based on such information, you must assume any responsibility arising out of such use of the information. Fujitsu assumes no liability for any damages whatsoever arising out of the use of the information.

Any information in this document, including descriptions of function and schematic diagrams, shall not be construed as license of the use or exercise of any intellectual property right, such as patent right or copyright, or any other right of Fujitsu or any third party or does Fujitsu warrant non-infringement of any third-party's intellectual property right or other right by using such information. Fujitsu assumes no liability for any infringement of the intellectual property rights or other rights of third parties which would result from the use of information contained herein.

The products described in this document are designed, developed and manufactured as contemplated for general use, including without limitation, ordinary industrial use, general office use, personal use, and household use, but are not designed, developed and manufactured as contemplated (1) for use accompanying fatal risks or dangers that, unless extremely high safety is secured, could have a serious effect to the public, and could lead directly to death, personal injury, severe physical damage or other loss (i.e., nuclear reaction control in nuclear facility, aircraft flight control, air traffic control, mass transport control, medical life support system, missile launch control in weapon system), or (2) for use requiring extremely high reliability (i.e., submersible repeater and artificial satellite).

Please note that Fujitsu will not be liable against you and/or any third party for any claims or damages arising in connection with above-mentioned uses of the products.

Any semiconductor devices have an inherent chance of failure. You must protect against injury, damage or loss from such failures by incorporating safety design measures into your facility and equipment such as redundancy, fire protection, and prevention of over-current levels and other abnormal operating conditions.

If any products described in this document represent goods or technologies subject to certain restrictions on export under the Foreign Exchange and Foreign Trade Law of Japan, the prior authorization by Japanese government will be required for export of those products from Japan.