

MMA7660FC Board Mounting Guidelines

by: Laura Salhuana

ACRONYMS

- PCB: Printed Circuit Board
- DFN: Dual Flat No-Lead
- Cl: Chlorine
- Br: Bromine
- RoHS: Restrictions on Hazardous Substances
- Sn: tin
- Pb: lead
- Ag: silver
- Cu: copper

ABSTRACT

This application note discusses board mounting guidelines and considerations for the MMA7660FC sensor. The first topic that will be discussed is the minimum recommended footprint for surface mount applications. This is a critical portion of design and if not done properly can affect soldering connection interface between the board and the package. Next, will be soldering and mounting guidelines and considerations for the DFN accelerometer sensor to a PCB. These suggested methods will minimize the stress on the package after board mount. Following these guidelines and considerations for board mounting will result in better performance from the MMA7660FC sensor.

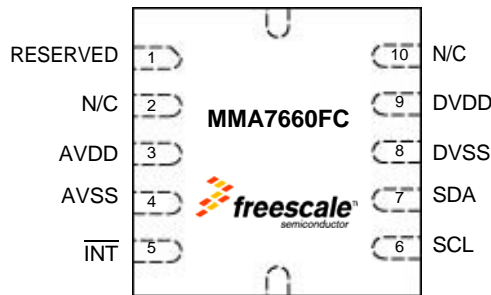
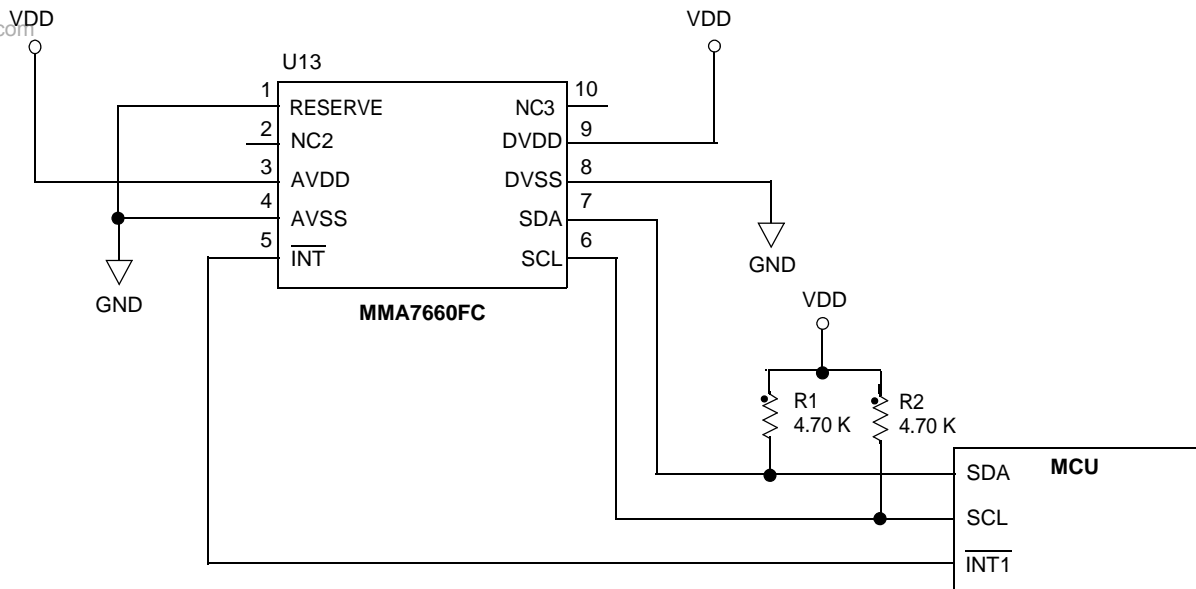

Figure 1. Pin Connections

Table 1. PIN DESCRIPTION

Pin #	Pin Name	Description	Pin Status
1	RESERVED	Connect to AVSS (Pin 4)	Input
2	N/C	No Internal Connection, leave unconnected or connect to Ground	Input
3	AVDD	Analog Power	Input
4	AVSS	Analog Ground	Input
5	INT	Interrupt/Data Ready	Output
6	SCL	I ² C Serial Clock	Input
7	SDA	I ² C Serial Data	Open Drain
8	DVSS	Digital I/O Ground	Input
9	DVDD	Digital I/O Power	Input
10	N/C	No Internal Connection, recommended to connect to Ground	Input



NOTE: A 10 μ F ceramic capacitor can be placed connecting pin 3 (AVDD) to pin 4 (AVSS). In addition, another 10 μ F ceramic capacitor can be placed connecting pin 9 (DVDD) to pin 8 (DVSS). The capacitors should be placed close to the pins of the MMA7660FC and is recommended for testing and to adequately decouple the accelerometer from noise on the power supply.

Figure 2. I²C Connection to MCU

MINIMUM RECOMMENDED FOOTPRINT FOR SURFACE MOUNTED APPLICATIONS

Surface mount board layout is a critical portion of the total design. The footprint for the surface mount packages must be the correct size to ensure proper solder connection interface between the board and the package. With the correct footprint, the packages will self-align when subjected to a solder reflow process. It is always recommended to design boards with a solder mask layer to avoid bridging and shorting between solder pads.

SOLDERING AND MOUNTING GUIDELINES FOR THE DFN ACCELEROMETER SENSOR TO A PRINTED CIRCUIT BOARD

These guidelines are for soldering and mounting the DFN package inertial sensors to PCBs. The purpose is to minimize the stress on the package after board mounting. The MMA7660 digital output accelerometer uses the DFN package platform. This section describes suggested methods of soldering these devices to the PCB for consumer applications. [Pages 5, 6, and 7](#) show the package outline drawing for the package.

OVERVIEW OF SOLDERING CONSIDERATIONS

Information provided here is based on experiments executed on DFN devices. They do not represent exact conditions present at a customer site. Hence, information herein should be used as a guideline only and process and design optimizations are recommended to develop an application specific solution. It should be noted that with the proper PCB footprint and solder stencil designs the package will self-align during the solder reflow process. The following are the recommended guidelines to follow for mounting DFN sensors for consumer applications.

Halogen Content

This package is designed to be halogen free, exceeding most industry and customer standards. Halogen Free means that no homogeneous material within the assembly package shall contain Cl in excess of 700 ppm or 0.07% weight/weight or Br in excess of 900 ppm or 0.09% weight/weight.

PCB Mounting Recommendations

www.DataSheet4U.com

1. The PCB land should be designed with Non Solder Mask Defined (NSMD) as shown in [Figure 3](#) and [Figure 4](#).
2. No additional via pattern underneath package.
3. PCB land pad is 0.825 mm x 0.3 mm as shown in [Figure 3](#) and [Figure 4](#).
4. Do not solder down smaller side tabs on either end of the package.
5. The solder mask opening is equal to the size of the PCB land pad plus 0.15 mm.
6. The stencil aperture size is equal to the PCB land pad – minus 0.03 mm total.
7. Stencil thickness should be 75 μm .
8. Do not place any components or vias at a distance less than 2 mm from the package land area. This may cause additional package stress if it is too close to the package land area.
9. Signal traces connected to pads should be as symmetric as possible. Put dummy traces on NC pads in order to have same length of exposed trace for all pads. Signal traces with 0.15 mm width and minimum 0.5 mm length for all PCB land pads near the package are recommended as shown in [Figure 3](#) and [Figure 4](#). Wider trace can be continued after the 0.5 mm zone.
10. Use a standard pick and place process and equipment. Do not use a hand soldering process.
11. It is recommended to use a no clean solder paste.
12. Do not use a screw down or stacking to fix the PCB into an enclosure because this could bend the PCB putting stress on the package.
13. The PCB should be rated for the multiple lead-free reflow condition with max 260°C temperature.
14. No copper traces on top layer of PCB under the package. This will cause planarity issues with board mount.

Freescalé DFN sensors are compliant with RoHS, having halide free molding compound (green) and lead-free terminations. These terminations are compatible with tin-lead (Sn-Pb) as well as tin-silver-copper (Sn-Ag-Cu) solder paste soldering processes. Reflow profiles applicable to those processes can be used successfully for soldering the devices.

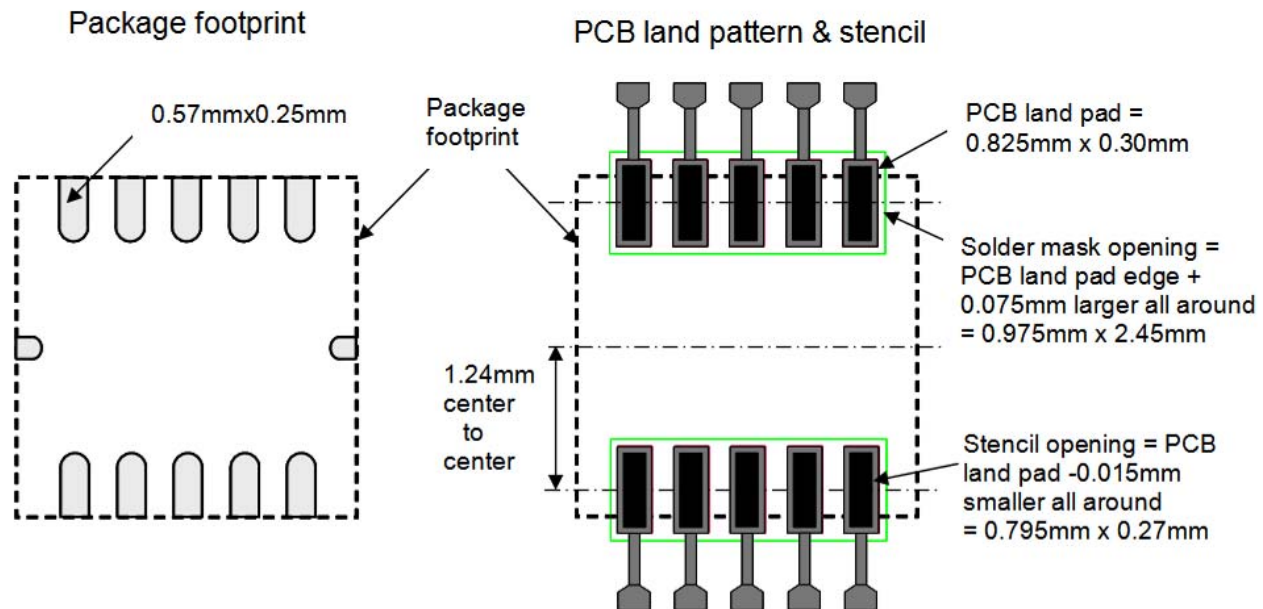

Figure 3. Package Footprint, PCB Land Pattern, and Stencil Design

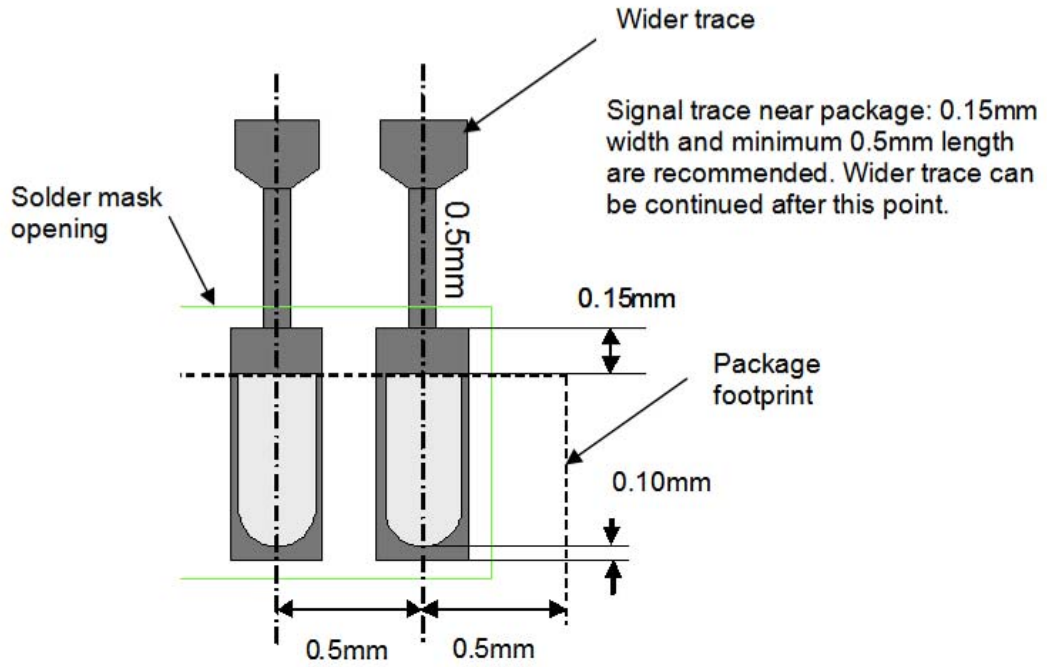
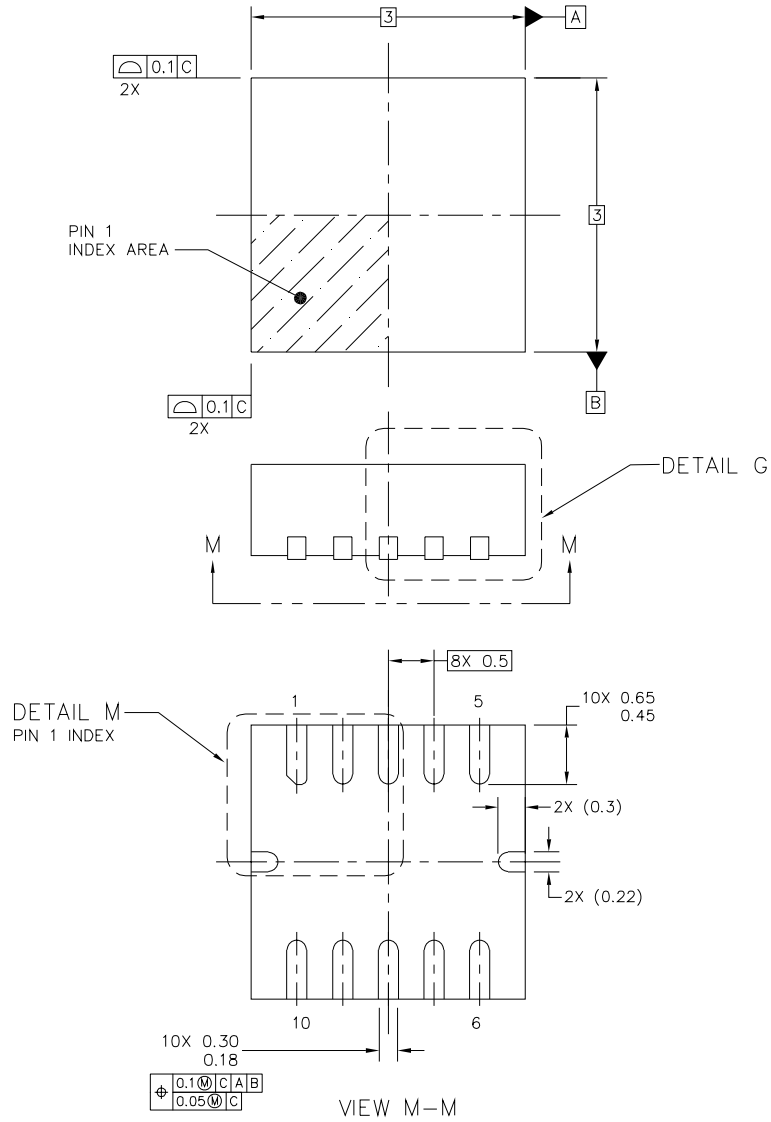

Figure 4. PCB Land Pattern Detail

PACKAGE DIMENSIONS

www.DataSheet4U.com



© FREESCALE SEMICONDUCTOR, INC. ALL RIGHTS RESERVED.	MECHANICAL OUTLINE	PRINT VERSION NOT TO SCALE	
TITLE: DUAL FLAT NO LEAD COL PACKAGE (DFN-COL) 10 TERMINAL, 0.5 PITCH (3 X 3 X 0.9)	DOCUMENT NO: 98ASA10816D	REV: B	
	CASE NUMBER: 2002-03	14 AUG 2008	
	STANDARD: NON JEDEC		

AN3839

PACKAGE DIMENSIONS

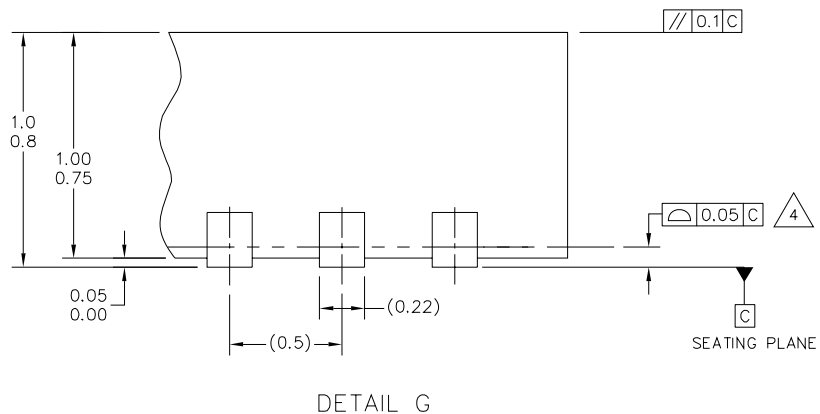
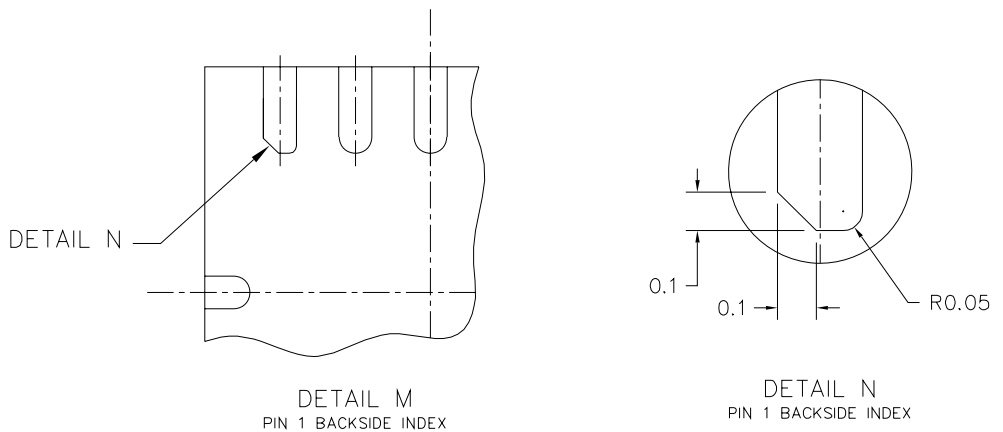

© FREESCALE SEMICONDUCTOR, INC. ALL RIGHTS RESERVED.	MECHANICAL OUTLINE	PRINT VERSION NOT TO SCALE	
TITLE: DUAL FLAT NO LEAD COL PACKAGE (DFN-COL) 10 TERMINAL, 0.5 PITCH (3 X 3 X 0.9)	DOCUMENT NO: 98ASA10816D	REV: B	
	CASE NUMBER: 2002-03	14 AUG 2008	
	STANDARD: NON JEDEC		

PACKAGE DIMENSIONS

www.DataSheet4U.com

NOTES:

1. ALL DIMENSIONS ARE IN MILLIMETERS.
2. INTERPRET DIMENSIONS AND TOLERANCES PER ASME Y14.5M-1994.
3. THIS IS NON JEDEC REGISTERED PACKAGE.
4.  COPLANARITY APPLIES TO LEADS AND ALL OTHR BOTTOM SURFACE METALLIZATION.
5. MIN. METAL GAP SHOULD BE 0.2MM.

© FREESCALE SEMICONDUCTOR, INC. ALL RIGHTS RESERVED.	MECHANICAL OUTLINE	PRINT VERSION NOT TO SCALE	
TITLE: DUAL FLAT NO LEAD COL PACKAGE (DFN-COL) 10 TERMINAL, 0.5 PITCH (3 X 3 X 0.9)	DOCUMENT NO: 98ASA10816D	REV: B	
	CASE NUMBER: 2002-03	14 AUG 2008	
	STANDARD: NON JEDEC		

AN3839

How to Reach Us:

Home Page:

www.freescale.com

Web Support:

<http://www.freescale.com/support>

USA/Europe or Locations Not Listed:

Freescale Semiconductor, Inc.
Technical Information Center, EL516
2100 East Elliot Road
Tempe, Arizona 85284
1-800-521-6274 or +1-480-768-2130
www.freescale.com/support

Europe, Middle East, and Africa:

Freescale Halbleiter Deutschland GmbH
Technical Information Center
Schatzbogen 7
81829 Muenchen, Germany
+44 1296 380 456 (English)
+46 8 52200080 (English)
+49 89 92103 559 (German)
+33 1 69 35 48 48 (French)
www.freescale.com/support

Japan:

Freescale Semiconductor Japan Ltd.
Headquarters
ARCO Tower 15F
1-8-1, Shimo-Meguro, Meguro-ku,
Tokyo 153-0064
Japan
0120 191014 or +81 3 5437 9125
support.japan@freescale.com

Asia/Pacific:

Freescale Semiconductor China Ltd.
Exchange Building 23F
No. 118 Jianguo Road
Chaoyang District
Beijing 100022
China
+86 010 5879 8000
support.asia@freescale.com

For Literature Requests Only:

Freescale Semiconductor Literature Distribution Center
P.O. Box 5405
Denver, Colorado 80217
1-800-441-2447 or +1-303-675-2140
Fax: +1-303-675-2150
LDCForFreescaleSemiconductor@hibbertgroup.com

Information in this document is provided solely to enable system and software implementers to use Freescale Semiconductor products. There are no express or implied copyright licenses granted hereunder to design or fabricate any integrated circuits or integrated circuits based on the information in this document.

Freescale Semiconductor reserves the right to make changes without further notice to any products herein. Freescale Semiconductor makes no warranty, representation or guarantee regarding the suitability of its products for any particular purpose, nor does Freescale Semiconductor assume any liability arising out of the application or use of any product or circuit, and specifically disclaims any and all liability, including without limitation consequential or incidental damages. "Typical" parameters that may be provided in Freescale Semiconductor data sheets and/or specifications can and do vary in different applications and actual performance may vary over time. All operating parameters, including "Typicals", must be validated for each customer application by customer's technical experts. Freescale Semiconductor does not convey any license under its patent rights nor the rights of others. Freescale Semiconductor products are not designed, intended, or authorized for use as components in systems intended for surgical implant into the body, or other applications intended to support or sustain life, or for any other application in which the failure of the Freescale Semiconductor product could create a situation where personal injury or death may occur. Should Buyer purchase or use Freescale Semiconductor products for any such unintended or unauthorized application, Buyer shall indemnify and hold Freescale Semiconductor and its officers, employees, subsidiaries, affiliates, and distributors harmless against all claims, costs, damages, and expenses, and reasonable attorney fees arising out of, directly or indirectly, any claim of personal injury or death associated with such unintended or unauthorized use, even if such claim alleges that Freescale Semiconductor was negligent regarding the design or manufacture of the part.

Freescale™ and the Freescale logo are trademarks of Freescale Semiconductor, Inc. All other product or service names are the property of their respective owners.

© Freescale Semiconductor, Inc. 2009. All rights reserved.