

# DATA SHEET

## CHIP RESISTORS

RC0603

5%; 1%

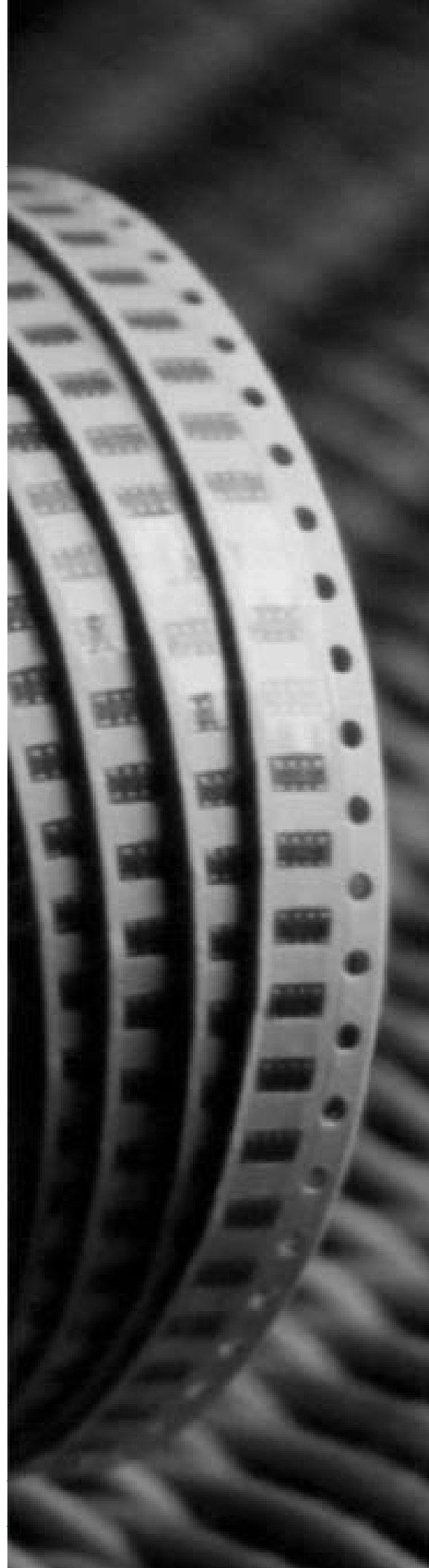

SCOPE

This specification describes RC 0603 series chip resistors made by thick film process.

ORDERING INFORMATION

Part number is identified by the series, size, tolerance, packing style, temperature coefficient, special type and resistance value.

**RC0603** X X X XX XXXX  
(1) (2) (3) (4) (5)

**(1) TOLERANCE**

F = ±1%  
J = ±5%

**(2) PACKAGING TYPE**

R = Paper taping reel  
C = Bulk case

**(3) TEMPERATURE CHARACTERISTIC OF RESISTANCE**

F = ±100ppm/°C  
G = ±200ppm/°C  
I = ±300ppm/°C  
- = Base on spec

**(4) SPECIAL TYPE**

07 = 7 inch dia. Reel  
10 = 10 inch dia. Reel  
13 = 13 inch dia. Reel

**(5) RESISTANCE VALUE:**

R056, R56, 5R6, 56R, 560R, 5K6, 56K, 56M.

MARKING

**RC0603**



E-24 series: 3 digits

First two digits for significant figure and 3rd digit for number of zeros



E-96 series: 3 digits for 0603±1% EIA-96 marking method



For 0603±1% E-24 series, one short bar under marking letter

**EIA - 96 MARKING RULE**

Table I

Code	Value	Code	Value	Code	Value	Code	Value	Code	Value	Code	Value	Code	Value	Code	Value
01	100	13	133	25	178	37	237	49	316	61	422	73	562	85	750
02	102	14	137	26	182	38	243	50	324	62	432	74	576	86	768
03	105	15	140	27	187	39	249	51	332	63	442	75	590	87	787
04	107	16	143	28	191	40	255	52	340	64	453	76	604	88	806
05	110	17	147	29	196	41	261	53	348	55	464	77	619	89	825
06	113	18	150	30	200	42	267	54	357	66	475	78	634	90	845
07	115	19	154	31	205	43	274	55	365	67	487	79	649	91	866
08	118	20	158	32	210	44	280	56	374	68	499	80	665	92	887
09	121	21	162	33	215	45	287	57	383	69	511	81	681	93	909
10	124	22	165	34	221	46	294	58	392	70	523	82	698	94	931
11	127	23	169	35	226	47	301	59	402	71	536	83	715	95	953
12	130	24	174	36	232	48	309	60	412	72	549	84	732	96	976

Table I. shows the first two digits of the three-digit EIA-96 part-marking scheme.

The third character is a letter multiplier:

X=10<sup>-1</sup>, Y=10<sup>-2</sup>, A=10<sup>0</sup>, B=10<sup>1</sup>, C=10<sup>2</sup>, D=10<sup>3</sup>, E=10<sup>4</sup>, F=10<sup>5</sup>

**CONSTRUCTION**

The resistors are constructed out of a high-grade ceramic body. Internal metal electrodes are added at each end and connected by a resistive paste. The composition of the paste is adjusted to give the approximate required resistance and laser cutting of this resistive layer that achieves tolerance trims the value. The resistive layer is covered with a protective coat and printed with the resistance value. Finally, the two external terminations are added. See fig. 4.

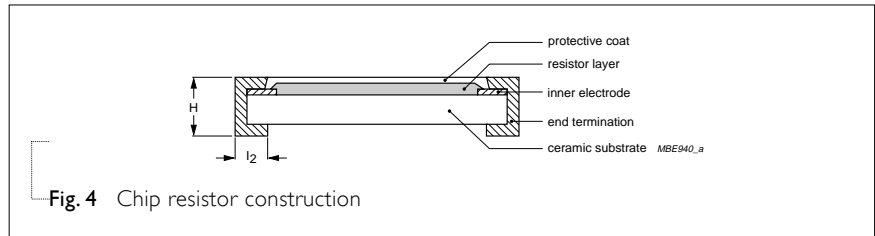

**DIMENSIONS**

Table 2

TYPE	RC0603
L (mm)	1.60±0.1
W (mm)	0.80±0.10
H (mm)	0.45±0.10
l <sub>1</sub> (mm)	0.25±0.15
l <sub>2</sub> (mm)	0.25±0.15

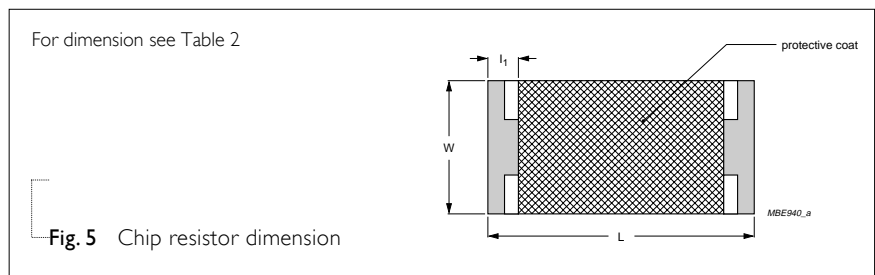

**POWER RATING**

**RATED POWER AT 70°C, RC0603 1/10W**

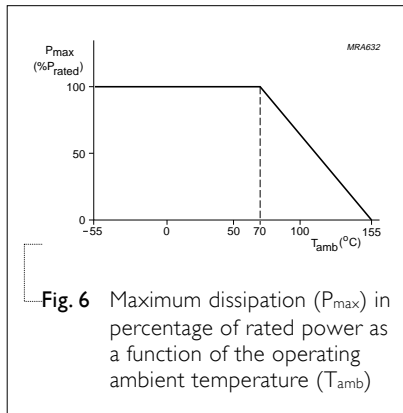

**ELECTRICAL CHARACTERISTICS**

Table 3

CHARACTERISTICS	RC0603 1/10 W
Operating Temperature Range	-55°C to +155°C
Maximum Working Voltage	50V
Maximum Overload Voltage	100V
Dielectric Withstanding Voltage	100V
Resistance Range	1Ω to 22MΩ (E24) 1Ω to 4.7MΩ (E96) Zero Ohm Jumper<0.05Ω
Temperature Coefficient	±200ppm/°C (10Ω<R≤10MΩ) ±300ppm/°C (1Ω≤R<10Ω, R>10MΩ)

**RATED VOLTAGE:**

The DC or AC (rms) continuous working voltage corresponding to the rated power is determined by the following formula:

$$V = \sqrt{P \times R}$$

Where

V=Continuous rated DC or AC (rms) working voltage (V)

P=Rated power (W)

R=Resistance value (Ω)

**TAPING REEL**

Table 4

DIMENSION	RC0603
Tape Width	8mm
ØA (mm)	180+0/-3
ØB (mm)	60+1/-0
ØC (mm)	13.0±0.2
W (mm)	9.0±0.3
T <sub>max</sub> (mm)	11.4±1

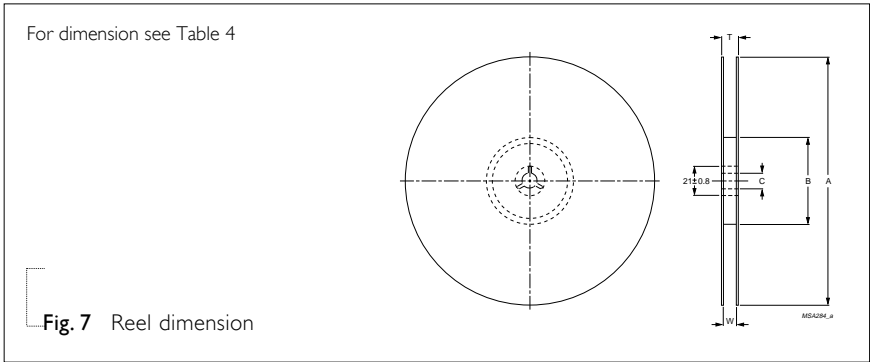

**PAPER TAPE SPECIFICATION**

Table 5

DIMENSION	RC0603
A (mm)	1.1±0.1
B (mm)	1.90±0.1
W (mm)	8.0±0.2
E (mm)	1.75±0.1
F (mm)	3.5±0.05
P <sub>0</sub> (mm)	4.0±0.1
P <sub>1</sub> (mm)	4.0±0.05
P <sub>2</sub> (mm)	2.0±0.05
ØD <sub>0</sub> (mm)	1.5+0.1/-0
T <sub>max</sub> (mm)	0.70±0.10

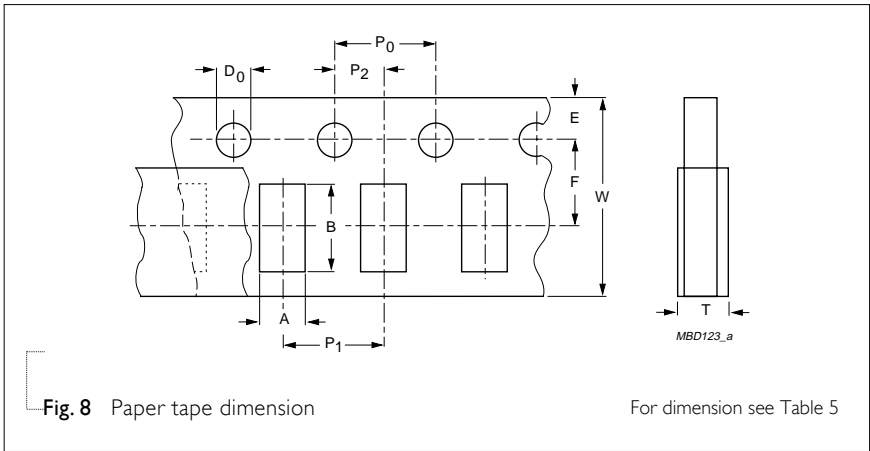

**PACKING METHODS**

**LEADER/TRAILER TAPE SPECIFICATION**

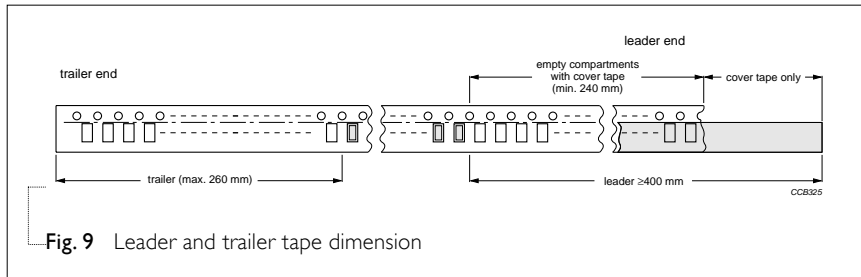
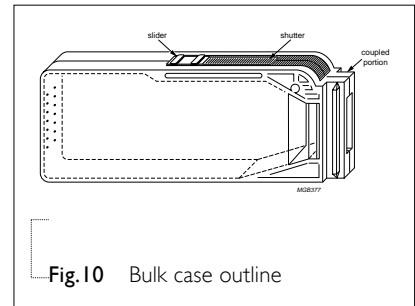

Table 6 Packing style and packaging quantity

PACKING STYLE	REEL DIMENSION	RC0603
Paper Taping Reel (R)	7" (178 mm)	5,000
	10" (254 mm)	10,000
	13" (330 mm)	20,000
Bulk Cassette (C)		25,000

**BULK CASSETTE**



TYPE	TEST METHOD	ACCEPTANCE STANDARD				
<b>Temperature Coefficient of Resistance (T.C.R.)</b>	<p>Measure resistance at +25°C or specified room temperature as R<sub>1</sub>, then measure at -55°C or +125°C respectively as R<sub>2</sub></p> <p>Determine the temperature coefficient of resistance from the following formula:</p>	<p><b>Formula</b></p> <hr/> $T.C.R. = \frac{R_2 - R_1}{R_1(t_2 - t_1)} \times 10^6 \text{ (ppm/°C)}$ <p>Where                      t<sub>1</sub> = +25°C or specified room temperature                      t<sub>2</sub> = -55°C or +125°C test temperature                      R<sub>1</sub> = resistance at reference temperature in ohms                      R<sub>2</sub> = resistance at test temperature in ohms</p>	Refer to table 3			
<b>Thermal Shock</b>	<p>At -55±3°C for 2 minutes and at +125±2°C for 2 minutes as one cycle. After 5 cycles, the specimen shall be stabilized at room temp.</p> <p>Measure the resistance to determine ΔR/R(%) after one more hour.</p>	<p>±(0.5%+0.05Ω) for 1% tol.                      ±(1%+0.05Ω) for 5% tol.</p>				
<b>Low Temperature Operation</b>	<p>Place the specimen in a test chamber maintained at -65 (+0/-5)°C. After one hour stabilization at this temperature, full rated working voltage shall be applied for 45 (+5/-0) minutes. Have 15 (+5/-0) minutes after remove the voltage, the specimen shall be removed from the chamber and stabilized at room temperature for 24 hrs.</p> <p>Measure the resistance to determine ΔR/R(%).</p>	<p>±(0.5%+0.05Ω) for 1% tol.                      ±(1.0%+0.05Ω) for 5% tol.                      No visible damage</p>				
<b>Short Time Overload</b>	<p>Apply 2.5 times of rated voltage but not exceeding the maximum overload voltage for 5 seconds. Have the specimen stabilized at room temperature for 30 minutes minimum.</p> <p>Measure the resistance to determine ΔR/R(%).</p>	<p>±(1.0%+0.05Ω) for 1% tol.                      ±(2.0%+0.05Ω) for 5% tol.                      No visible damage</p>				
<b>Insulation Resistance</b>	<p>Place the specimen in the jig and apply a rated continues overload voltage (R.C.O.V) for one minute as shown.</p> <p>Measure the insulation resistance.</p>	<table border="1"> <tr> <td><b>Type</b></td> <td><b>RC0603</b></td> </tr> <tr> <td><b>Voltage</b></td> <td>100V</td> </tr> </table> <p>≥10,000MΩ</p>	<b>Type</b>	<b>RC0603</b>	<b>Voltage</b>	100V
<b>Type</b>	<b>RC0603</b>					
<b>Voltage</b>	100V					
<b>Dielectric Withstand Voltage</b>	<p>Place the specimen in the jig and apply a specified value continuous overload voltage as shown for one minute.</p>	<table border="1"> <tr> <td><b>Type</b></td> <td><b>RC0603</b></td> </tr> <tr> <td><b>Voltage</b></td> <td>100V</td> </tr> </table> <p>Breakdown voltage &gt; specification and without open/short</p>	<b>Type</b>	<b>RC0603</b>	<b>Voltage</b>	100V
<b>Type</b>	<b>RC0603</b>					
<b>Voltage</b>	100V					
<b>Resistance To Soldering Heat</b>	<p>Immerse the specimen in the solder pot at 260±5°C. for 10±1 seconds. Have the specimen stabilized at room temperature for 30 minutes minimum.</p> <p>Measure the resistance to determine ΔR/R(%).</p>	<p>±(0.5%+0.05Ω) for 1% tol.                      ±(1.0%+0.05Ω) for 5% tol.                      No visible damage</p>				

TYPE	TEST METHOD	ACCEPTANCE STANDARD
<b>Moisture Resistance</b>	Place the specimen in the test chamber and subject to 42 damp heat cycles. Each one of which consists of the steps 1 to 7 as figure 12. The total length of test is 1,000 hours. Have the specimen stabilized at room temperature for 24 hours after testing. Measure the resistance to determine $\Delta R/R(\%)$ .	$\pm(0.5\%+0.05\Omega)$ for 1% tol. $\pm(2.0\%+0.05\Omega)$ for 5% tol. No visible damage
<b>Life</b>	Place the specimen in the oven at $70\pm 2^{\circ}\text{C}$ . Apply the rated voltage to the specimen at the 1.5 hours on and 0.5 hour off cycle. The total length of test is 1,000 hours. Have the specimen stabilized at room temperature for one hour minimum after testing. Measure the $\Delta R/R(\%)$ .	$\pm(1\%+0.05\Omega)$ for 1% tol. $\pm(3\%+0.05\Omega)$ for 5% tol. No visible damage
<b>Solderability</b>	Immerse the specimen in the solder pot at $230\pm 5^{\circ}\text{C}$ for 5 sec.	At least 95% solder coverage on the termination

**Bending Strength** Mount the specimen on a test board as shown in the figure 11. Slowly apply the force till the board is bent for  $5\pm 1$  sec.  
Measure the  $\Delta R/R(\%)$  at this position.

**Type** RC0603  
**Bent Distance (d)** 5mm

$\pm(1.0\%+0.05\Omega)$  for 1% tol.  
 $\pm(1.0\%+0.05\Omega)$  for 5% tol.  
No visible damage

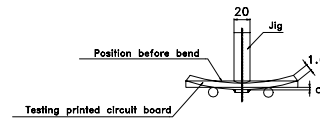

**Fig. 11** Principle of the bending test

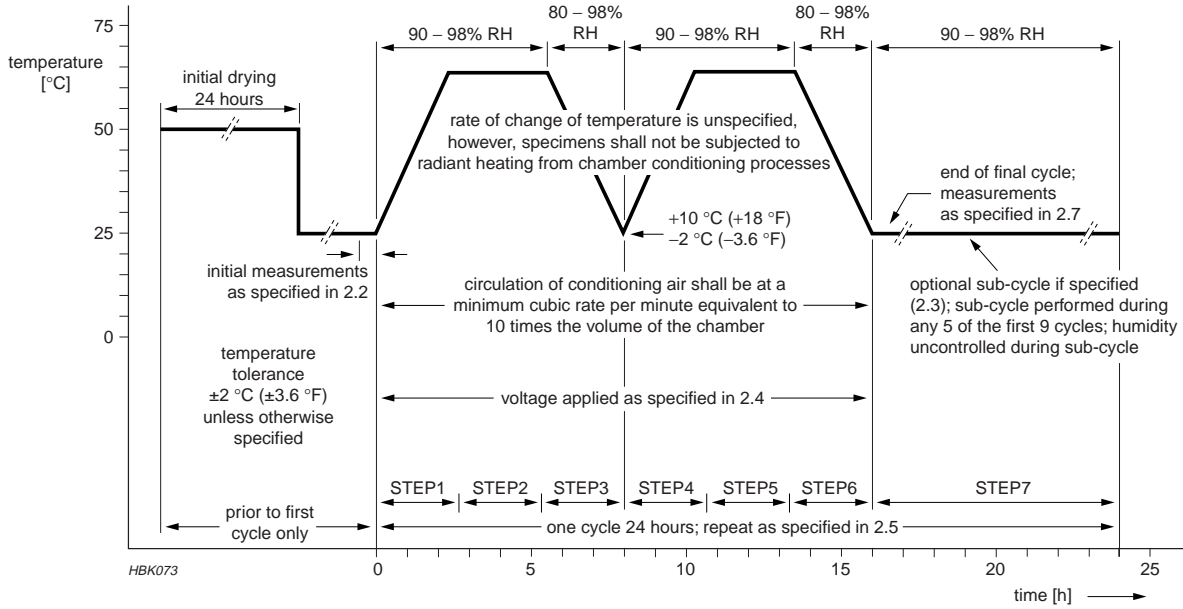

Fig. 12 Conditions by change of temperature