

**32****32192/32195/32196** Group

Hardware Manual

RENESAS MCU  
M32R FAMILY / M32R/ECU SERIES

All information contained in these materials, including products and product specifications, represents information on the product at the time of publication and is subject to change by Renesas Technology Corp. without notice. Please review the latest information published by Renesas Technology Corp. through various means, including the Renesas Technology Corp. website (<http://www.renesas.com>).

## Notes regarding these materials

1. This document is provided for reference purposes only so that Renesas customers may select the appropriate Renesas products for their use. Renesas neither makes warranties or representations with respect to the accuracy or completeness of the information contained in this document nor grants any license to any intellectual property rights or any other rights of Renesas or any third party with respect to the information in this document.
2. Renesas shall have no liability for damages or infringement of any intellectual property or other rights arising out of the use of any information in this document, including, but not limited to, product data, diagrams, charts, programs, algorithms, and application circuit examples.
3. You should not use the products or the technology described in this document for the purpose of military applications such as the development of weapons of mass destruction or for the purpose of any other military use. When exporting the products or technology described herein, you should follow the applicable export control laws and regulations, and procedures required by such laws and regulations.
4. All information included in this document such as product data, diagrams, charts, programs, algorithms, and application circuit examples, is current as of the date this document is issued. Such information, however, is subject to change without any prior notice. Before purchasing or using any Renesas products listed in this document, please confirm the latest product information with a Renesas sales office. Also, please pay regular and careful attention to additional and different information to be disclosed by Renesas such as that disclosed through our website. (<http://www.renesas.com> )
5. Renesas has used reasonable care in compiling the information included in this document, but Renesas assumes no liability whatsoever for any damages incurred as a result of errors or omissions in the information included in this document.
6. When using or otherwise relying on the information in this document, you should evaluate the information in light of the total system before deciding about the applicability of such information to the intended application. Renesas makes no representations, warranties or guaranties regarding the suitability of its products for any particular application and specifically disclaims any liability arising out of the application and use of the information in this document or Renesas products.
7. With the exception of products specified by Renesas as suitable for automobile applications, Renesas products are not designed, manufactured or tested for applications or otherwise in systems the failure or malfunction of which may cause a direct threat to human life or create a risk of human injury or which require especially high quality and reliability such as safety systems, or equipment or systems for transportation and traffic, healthcare, combustion control, aerospace and aeronautics, nuclear power, or undersea communication transmission. If you are considering the use of our products for such purposes, please contact a Renesas sales office beforehand. Renesas shall have no liability for damages arising out of the uses set forth above.
8. Notwithstanding the preceding paragraph, you should not use Renesas products for the purposes listed below:
  - (1) artificial life support devices or systems
  - (2) surgical implantations
  - (3) healthcare intervention (e.g., excision, administration of medication, etc.)
  - (4) any other purposes that pose a direct threat to human lifeRenesas shall have no liability for damages arising out of the uses set forth in the above and purchasers who elect to use Renesas products in any of the foregoing applications shall indemnify and hold harmless Renesas Technology Corp., its affiliated companies and their officers, directors, and employees against any and all damages arising out of such applications.
9. You should use the products described herein within the range specified by Renesas, especially with respect to the maximum rating, operating supply voltage range, movement power voltage range, heat radiation characteristics, installation and other product characteristics. Renesas shall have no liability for malfunctions or damages arising out of the use of Renesas products beyond such specified ranges.
10. Although Renesas endeavors to improve the quality and reliability of its products, IC products have specific characteristics such as the occurrence of failure at a certain rate and malfunctions under certain use conditions. Please be sure to implement safety measures to guard against the possibility of physical injury, and injury or damage caused by fire in the event of the failure of a Renesas product, such as safety design for hardware and software including but not limited to redundancy, fire control and malfunction prevention, appropriate treatment for aging degradation or any other applicable measures. Among others, since the evaluation of microcomputer software alone is very difficult, please evaluate the safety of the final products or system manufactured by you.
11. In case Renesas products listed in this document are detached from the products to which the Renesas products are attached or affixed, the risk of accident such as swallowing by infants and small children is very high. You should implement safety measures so that Renesas products may not be easily detached from your products. Renesas shall have no liability for damages arising out of such detachment.
12. This document may not be reproduced or duplicated, in any form, in whole or in part, without prior written approval from Renesas.
13. Please contact a Renesas sales office if you have any questions regarding the information contained in this document, Renesas semiconductor products, or if you have any other inquiries.

## General Precautions in the Handling of MPU/MCU Products

The following usage notes are applicable to all MPU/MCU products from Renesas. For detailed usage notes on the products covered by this manual, refer to the relevant sections of the manual. If the descriptions under General Precautions in the Handling of MPU/MCU Products and in the body of the manual differ from each other, the description in the body of the manual takes precedence.

### 1. Handling of Unused Pins

Handle unused pins in accord with the directions given under Handling of Unused Pins in the manual.

- The input pins of CMOS products are generally in the high-impedance state. In operation with an unused pin in the open-circuit state, extra electromagnetic noise is induced in the vicinity of LSI, an associated shoot-through current flows internally, and malfunctions occur due to the false recognition of the pin state as an input signal become possible. Unused pins should be handled as described under Handling of Unused Pins in the manual.

### 2. Processing at Power-on

The state of the product is undefined at the moment when power is supplied.

- The states of internal circuits in the LSI are indeterminate and the states of register settings and pins are undefined at the moment when power is supplied.

In a finished product where the reset signal is applied to the external reset pin, the states of pins are not guaranteed from the moment when power is supplied until the reset process is completed.

In a similar way, the states of pins in a product that is reset by an on-chip power-on reset function are not guaranteed from the moment when power is supplied until the power reaches the level at which resetting has been specified.

### 3. Prohibition of Access to Reserved Addresses

Access to reserved addresses is prohibited.

- The reserved addresses are provided for the possible future expansion of functions. Do not access these addresses; the correct operation of LSI is not guaranteed if they are accessed.

### 4. Clock Signals

After applying a reset, only release the reset line after the operating clock signal has become stable. When switching the clock signal during program execution, wait until the target clock signal has stabilized.

- When the clock signal is generated with an external resonator (or from an external oscillator) during a reset, ensure that the reset line is only released after full stabilization of the clock signal. Moreover, when switching to a clock signal produced with an external resonator (or by an external oscillator) while program execution is in progress, wait until the target clock signal is stable.

### 5. Differences between Products

Before changing from one product to another, i.e. to one with a different part number, confirm that the change will not lead to problems.

- The characteristics of MPU/MCU in the same group but having different part numbers may differ because of the differences in internal memory capacity and layout pattern. When changing to products of different part numbers, implement a system-evaluation test for each of the products.

REVISION HISTORY

32192/32195/32196 Group Hardware Manual

Rev.	Date	Description	
		Page	Summary
1.01	Jul 22, 2005	-	First edition issued
1.10	Apr 06, 2007	-	Add the 32195 Group
		-	Add M32192F8VWG, M32192F8UWG, and M32192F8TWG
		2-3	Add Note 1 to IE bit of PSW register
		5-6	Correct notes of IMASK register Incorrect) the Interrupt Request Mask Register (IMASK) in the EIT handler → Correct) the Interrupt Request Mask Register (IMASK)
		5-7	Add a note for SBI Control Register
		6-15	Add a description for FAENS bit of FMOD Register
		6-16	Add descriptions for ERASE bit and WRERR bit.
		6-19 to 21	Correct descriptions of FCNOT3 Register Add Table 6.5.2 and correct Figure 6.5.2
		6-34	Add Figure 6.6.7
		6-36	Correct the description of 4 Halfword Program command
		6-55	Add a note to 6.11 Notes on the Internal RAM
		8-33	Correct functions of b4 (12) WFnSEL bit in the Port Group n Input Level Setting Register
		8-35	Correct R/W status of GnDSEL bits in the Port Group n Output Drive Capability Setting Register
		8-39	Replace Figure 8.7.1
		8-40	Replace Figure 8.7.2
		8-41	Replace Figure 8.7.3
		8-42	Replace Figure 8.7.4
		8-43	Replace Figure 8.7.5
		8-44	Add a note about using input/output ports in input mode Add a note about the peripheral function input when it is set to the general-purpose port
		9-26	Correct functions of RINGSEL bit
		9-27	Correct descriptions of TREQFn bit and TENLn bit
		9-28	Correct the description of SELFEN bit
		10-114	Add descriptions to Reload register updates in TIO PWM output mode
		10-157	Correct a note of TOU Counters
		10-160	Correct a note of TOU Registers
		10-171	Correct read status of PO0LVSELGA bit and PO1LVSELGA bit
		10-176	Add descriptions to Reload register updates in TOUP PWM output mode
		11-21	Add Note 3 to ADSEL2 bit
		12-4	Replace Figure 12.1.1
		12-8	Correct the description of notes on using transmit interrupts
12-45,62	Add a note about switching from general-purpose to serial interface pin		
13-27	Correct the description of RBO bit		
13-28	Add descriptions to LBM bit and RST bit		

REVISION HISTORY

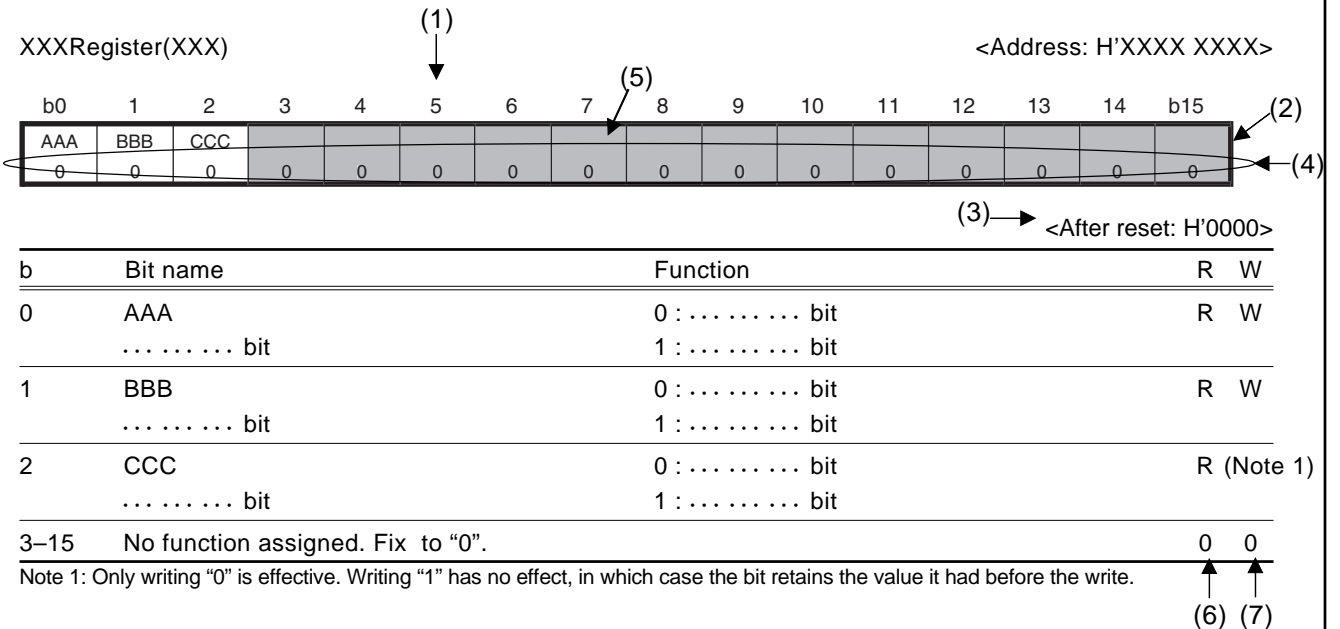
32192/32195/32196 Group Hardware Manual

Rev.	Date	Description	
		Page	Summary
1.10	Apr 06, 2007	13-31	Add a description to CRS bit
		13-118	Add Note 1 to Figure 13.3.4
		14-3	Replace Figure 14.1.1
		14-24	Replace Figure 14.2.7
		14-27	Correct the description of DRI Transfer Counter
		14-35	Add notes to Continuous Operation Mode
		14-36	Correct the description of DRI Event Counters
		19-2	Replace Figure 19.1.1
		20-2	Replace Figure 20.1.1
		20-3	Correct the description of XIN Oscillation Stoppage Detection Circuit
			Replace Figure 20.1.2
		Chap. 23	Add electrical characteristics of the 32195 and 32196
		23-3, 4, 7, 8, 11, 12, 15, 16	Correct parameters of VIH and VIL
			Correct parameters of VT+ and VT- (hysteresis)
		23-5, 9, 13, 17	
		23-24	Add Note 1 to TIN
		23-25, 47	Correct rated values of TCLK
			Add Note 1 to TCLK
		23-29, 51	Add Note 1 to tw(WAITH) and tw(WAITL)
		23-30, 52	Correct the note of Read Timing
		23-46	Correct Note 1 of TIN
		Appendix 1-2	Replace Dimensional Outline Drawing
		Appendix 1-3	Add 224 pin FBGA (PLBG0224GA-A)
Appendix4	Add correction of notes		

# Before Use

## • Guide to Understanding the Register Table

- (1) Bit number: Indicates a register's bit number.
  - (2) Register border: The registers enclosed with thick border lines must be accessed in halfwords or words.
  - (3) Status after reset: The initial state of each register after reset is indicated in hexadecimal or binary.
  - (4) Status after reset: The initial state of each register after reset is indicated bitwise.
    - 0: This bit is "0" after reset.
    - 1: This bit is "1" after reset.
    - ?: This bit is undefined after reset.
  - (5) The shaded bits mean that they have no functions assigned.
  - (6) Read conditions:
    - R: This bit can be accessed for read.
    - ?: The value read from this bit is undefined. (Reading this bit has no effect.)
    - 0: The value read from this bit is always "0".
    - 1: The value read from this bit is always "1".
  - (7) Write conditions:
    - W: This bit can be accessed for write.
    - N: This bit is write protected.
    - 0: To write to this bit, always write "0".
    - 1: To write to this bit, always write "1".
    - : Writing to this bit has no effect. (It does not matter whether this bit is set to "0" or "1" by writing in software.)
- Note: Care must be taken when writing to this bit. See Note in each register table.



## • Notation of active-low pins (signals)

The symbol "#" suffixed to the pin (or signal) names means that the pins (or signals) are active-low.

# Table of Contents

## CHAPTER 1 OVERVIEW

1.1	Outline of the 32192/32195/32196 Group	1-2
1.1.1	M32R Family CPU Core with Built-in FPU (M32R-FPU)	1-2
1.1.2	Built-in Multiplier/Accumulator	1-3
1.1.3	Built-in Single-precision FPU	1-3
1.1.4	Built-in Flash Memory and RAM	1-3
1.1.5	Built-in Clock Frequency Multiplier	1-5
1.1.6	Powerful Peripheral Functions Built-in	1-5
1.2	Block Diagram	1-6
1.3	Pin Functions	1-10
1.4	Pin Assignments	1-15

## CHAPTER 2 CPU

2.1	CPU Registers	2-2
2.2	General-purpose Registers	2-2
2.3	Control Registers	2-2
2.3.1	Processor Status Word Register: PSW (CR0)	2-3
2.3.2	Condition Bit Register: CBR (CR1)	2-4
2.3.3	Interrupt Stack Pointer: SPI (CR2) and User Stack Pointer: SPU (CR3)	2-4
2.3.4	Backup PC: BPC (CR6)	2-4
2.3.5	Floating-point Status Register: FPSR (CR7)	2-5
2.4	Accumulator	2-7
2.5	Program Counter	2-7
2.6	Data Formats	2-8
2.6.1	Data Types	2-8
2.6.2	Data Formats	2-9
2.7	Supplementary Explanation for BSET, BCLR, LOCK and UNLOCK Instruction Execution	2-14

## CHAPTER 3 ADDRESS SPACE

3.1	Outline of the Address Space	3-2
3.2	Operation Modes	3-3
3.3	Internal ROM and External Extension Areas	3-7
3.3.1	Internal ROM Area	3-7
3.3.2	External Extension Area	3-7
3.4	Internal RAM and SFR Areas	3-8
3.4.1	Internal RAM Area	3-8
3.4.2	SFR (Special Function Register) Area	3-8
3.5	EIT Vector Entry	3-48
3.6	ICU Vector Table	3-49
3.7	Notes on Address Space	3-52

## CHAPTER 4 EIT

4.1	Outline of EIT	4-2
4.2	EIT Events	4-3
4.2.1	Exception	4-3
4.2.2	Interrupt	4-5
4.2.3	Trap	4-6
4.3	EIT Processing Procedure	4-6
4.4	EIT Processing Mechanism	4-7
4.5	Acceptance of EIT Events	4-8
4.6	Saving and Restoring the PC and PSW	4-8
4.7	EIT Vector Entry	4-10
4.8	Exception Processing	4-11
4.8.1	Reserved Instruction Exception (RIE)	4-11
4.8.2	Address Exception (AE)	4-12
4.8.3	Floating-Point Exception (FPE)	4-13
4.9	Interrupt Processing	4-15
4.9.1	Reset Interrupt (RI)	4-15
4.9.2	System Break Interrupt (SBI)	4-15
4.9.3	External Interrupt (EI)	4-17
4.10	Trap Processing	4-18
4.10.1	Trap	4-18
4.11	EIT Priority Levels	4-19
4.12	Example of EIT Processing	4-20
4.13	Notes on EIT	4-22

## CHAPTER 5 INTERRUPT CONTROLLER (ICU)

5.1	Outline of the Interrupt Controller	5-2
5.2	ICU Related Registers	5-4
5.2.1	Interrupt Vector Register	5-5
5.2.2	Interrupt Request Mask Register	5-6
5.2.3	SBI (System Break Interrupt) Control Register	5-7
5.2.4	Interrupt Control Registers	5-8
5.3	Interrupt Request Sources in Internal Peripheral I/O	5-11
5.4	ICU Vector Table	5-12
5.5	Description of Interrupt Operation	5-13
5.5.1	Acceptance of Internal Peripheral I/O Interrupts	5-13
5.5.2	Processing by Internal Peripheral I/O Interrupt Handlers	5-14
5.6	Description of System Break Interrupt (SBI) Operation	5-17
5.6.1	Acceptance of SBI	5-17
5.6.2	SBI Processing by Handler	5-17



## CHAPTER 6 INTERNAL MEMORY

6.1	Outline of the Internal Memory	6-2
6.2	Internal RAM	6-2
6.3	Internal RAM Protect Function	6-2
6.4	Internal Flash Memory	6-11
6.5	Registers Associated with the Internal Flash Memory	6-14
6.5.1	Flash Mode Register	6-15
6.5.2	Flash Status Register	6-16
6.5.3	Flash Control Registers	6-17
6.5.4	Virtual Flash L Bank Registers	6-24
6.6	Programming the Internal Flash Memory	6-25
6.6.1	Outline of Internal Flash Memory Programming	6-25
6.6.2	Controlling Operation Modes during Flash Programming	6-31
6.6.3	Procedure for Programming/Erasing the Internal Flash Memory	6-35
6.6.4	Flash Programming Time (Reference)	6-43
6.7	Virtual Flash Emulation Function	6-44
6.7.1	Virtual Flash Emulation Area	6-46
6.7.2	Entering Virtual Flash Emulation Mode	6-49
6.8	Connecting to A Serial Programmer (CSIO Mode)	6-50
6.9	Connecting to A Serial Programmer (UART Mode)	6-52
6.10	Internal Flash Memory Protect Function	6-54
6.11	Notes on the Internal RAM	6-55
6.12	Notes on the Internal Flash Memory	6-55

## CHAPTER 7 RESET

7.1	Outline of Reset	7-2
7.2	Reset Operation	7-2
7.2.1	Reset at Power-on	7-3
7.2.2	Reset during Operation	7-3
7.2.3	Reset Vector Relocation during Flash Programming	7-3
7.3	Internal State upon Exiting Reset	7-4
7.4	Things to Be Considered upon Exiting Reset	7-4

## CHAPTER 8 INPUT/OUTPUT PORTS AND PIN FUNCTIONS

8.1	Outline of Input/Output Ports	8-2
8.2	Selecting Pin Functions	8-3
8.3	Input/Output Port Related Registers	8-9
8.3.1	Port Data Registers	8-12
8.3.2	Port Direction Registers	8-13
8.3.3	Port Operation Mode and Port Peripheral Function Select Registers	8-14
8.3.4	Port Input Special Function Control Register	8-29
8.4	Port Input Level Switching Function	8-32
8.5	Port Output Drive Capability Setting Function	8-34
8.6	Noise Canceller Control Function	8-37
8.7	Port Peripheral Circuits	8-39
8.8	Notes on Input/Output Ports	8-44

## CHAPTER 9 DMAC

9.1	Outline of the DMAC	9-2
9.2	DMAC Related Registers	9-4
9.2.1	DMA Channel Control Registers	9-6
9.2.2	DMA Software Request Generation Registers	9-29
9.2.3	DMA Source Address Registers	9-30
9.2.4	DMA Destination Address Registers	9-31
9.2.5	DMA Transfer Count Registers	9-32
9.2.6	DMA Interrupt Related Registers	9-33
9.3	Functional Description of the DMAC	9-38
9.3.1	DMA Transfer Request Sources	9-38
9.3.2	DMA Transfer Processing Procedure	9-44
9.3.3	Starting DMA	9-45
9.3.4	DMA Channel Priority	9-45
9.3.5	Gaining and Releasing Control of the Internal Bus	9-45
9.3.6	Transfer Units	9-46
9.3.7	Transfer Counts	9-46
9.3.8	Address Space	9-46
9.3.9	Transfer Operation	9-46
9.3.10	End of DMA and Interrupt	9-48
9.3.11	Each Register Status after Completion of DMA Transfer	9-48
9.4	Notes on the DMAC	9-49

## CHAPTER 10 MULTIJUNCTION TIMERS

10.1	Outline of Multijunction Timers	10-2
10.2	Common Units of Multijunction Timers	10-9
10.2.1	MJT Common Unit Register Map	10-10
10.2.2	Common Count Clock Select Function	10-12
10.2.3	Prescaler Unit	10-13
10.2.4	Clock Bus and Input/Output Event Bus Control Unit	10-14
10.2.5	Input Processing Control Unit	10-18
10.2.6	Output Flip-flop Control Unit	10-26
10.2.7	Interrupt Control Unit	10-34
10.3	TOP (Output-Related 16-Bit Timer)	10-60
10.3.1	Outline of TOP	10-60
10.3.2	Outline of Each Mode of TOP	10-62
10.3.3	TOP Related Register Map	10-64
10.3.4	TOP Control Registers	10-66
10.3.5	TOP Counters (TOP0CT–TOP10CT)	10-71
10.3.6	TOP Reload Registers (TOP0RL–TOP10RL)	10-72
10.3.7	TOP Correction Registers (TOP0CC–TOP10CC)	10-73
10.3.8	TOP Enable Control Registers	10-74
10.3.9	Operation in TOP Single-shot Output Mode (with Correction Function)	10-76
10.3.10	Operation in TOP Delayed Single-shot Output Mode (with Correction Function)	10-82
10.3.11	Operation in TOP Continuous Output Mode (without Correction Function)	10-87

10.4	TIO (Input/Output-Related 16-Bit Timer)	10-90
10.4.1	Outline of TIO	10-90
10.4.2	Outline of Each Mode of TIO	10-92
10.4.3	TIO Related Register Map	10-95
10.4.4	TIO Control Registers	10-97
10.4.5	TIO Counters (TIO0CT–TIO9CT)	10-105
10.4.6	TIO Reload 0/Measure Registers (TIO0RL0–TIO9RL0)	10-106
10.4.7	TIO Reload 1 Registers (TIO0RL1–TIO9RL1)	10-107
10.4.8	TIO Enable Control Registers	10-108
10.4.9	Operation in TIO Measure Free-Run/Clear Input Modes	10-110
10.4.10	Operation in TIO Noise Processing Input Mode	10-112
10.4.11	Operation in TIO PWM Output Mode	10-113
10.4.12	Operation in TIO Single-shot Output Mode (without Correction Function)	10-117
10.4.13	Operation in TIO Delayed Single-shot Output Mode (without Correction Function)	10-119
10.4.14	Operation in TIO Continuous Output Mode (without Correction Function)	10-121
10.5	TMS (Input-Related 16-Bit Timer)	10-123
10.5.1	Outline of TMS	10-123
10.5.2	Outline of TMS Operation	10-123
10.5.3	TMS Related Register Map	10-125
10.5.4	TMS Control Registers	10-126
10.5.5	TMS Counters (TMS0CT, TMS1CT)	10-127
10.5.6	TMS Measure Registers (TMS0MR3–0, TMS1MR3–0)	10-127
10.5.7	Operation of TMS Measure Input	10-128
10.6	TML (Input-Related 32-Bit Timer)	10-129
10.6.1	Outline of TML	10-129
10.6.2	Outline of TML Operation	10-130
10.6.3	TML Related Register Map	10-130
10.6.4	TML Control Registers	10-131
10.6.5	TML Counters	10-132
10.6.6	TML Measure Registers	10-132
10.6.7	Operation of TML Measure Input	10-133
10.7	TID (Input-Related 16-Bit Timer)	10-135
10.7.1	Outline of TID	10-135
10.7.2	TID Related Register Map	10-137
10.7.3	TID Control & Prescaler Enable Registers	10-138
10.7.4	TID Counters (TID0CT and TID1CT)	10-140
10.7.5	TID Reload Registers (TID0RL and TID1RL)	10-140
10.7.6	Outline of Each Mode of TID	10-141
10.8	TOU (Output-Related 24-Bit Timer)	10-146
10.8.1	Outline of TOU	10-146
10.8.2	Outline of Each Mode of TOU	10-148
10.8.3	TOU Related Register Map	10-150
10.8.4	TOU Control Registers	10-153
10.8.5	Shorting Prevention Function Registers	10-155
10.8.6	TOU Counters	10-157
10.8.7	TOU Reload Registers	10-160
10.8.8	TOU Enable Protect Registers	10-163

10.8.9	TOU Count Enable Registers	10-164
10.8.10	PWMOFF Input Processing Control Registers	10-166
10.8.11	PWM Output Disable Control Registers	10-168
10.8.12	PWM Output Disable Level Control Registers	10-171
10.8.13	PWMOFF Function Enable Registers	10-173
10.8.14	Operation in TOU PWM Output Mode (without Correction Function)	10-174
10.8.15	Operation in TOU Single-shot PWM Output Mode (without Correction Function)	10-180
10.8.16	Operation in TOU Delayed Single-shot Output Mode (without Correction Function)	10-182
10.8.17	Operation in TOU Single-shot Output Mode (without Correction Function)	10-184
10.8.18	Operation in TOU Continuous Output Mode (without Correction Function)	10-186
10.8.19	0% or 100% Duty-Cycle Wave Output during PWM Output and Single-shot PWM Output Modes	10-188
10.8.20	PWM Output Disable Function	10-193
10.8.21	Shorting Prevention Function	10-197
10.8.22	Example Application for Using the 32192/32195/32196 in Motor Control	10-201

## CHAPTER 11 A/D CONVERTER

11.1	Outline of A/D Converter	11-2
11.1.1	Conversion Modes	11-6
11.1.2	Operation Modes	11-6
11.1.3	Special Operation Modes	11-9
11.1.4	A/D Converter Interrupt and DMA Transfer Requests	11-12
11.1.5	Sample-and-Hold Function	11-12
11.1.6	Simultaneous Sampling Function	11-13
11.2	A/D Converter Related Registers	11-15
11.2.1	A/D Single Mode Register 0	11-17
11.2.2	A/D Single Mode Register 1	11-19
11.2.3	A/D Single Mode Register 2	11-21
11.2.4	A/D Scan Mode Register 0	11-22
11.2.5	A/D Scan Mode Register 1	11-24
11.2.6	A/D Conversion Speed Control Register	11-26
11.2.7	A/D Disconnection Detection Assist Function Control Register	11-27
11.2.8	A/D Disconnection Detection Assist Method Select Register	11-28
11.2.9	A/D Successive Approximation Register	11-31
11.2.10	A/D Compare Data Register	11-32
11.2.11	10-bit A/D Data Registers	11-33
11.2.12	8-bit A/D Data Registers	11-34
11.3	Functional Description of A/D Converter	11-35
11.3.1	How to Find Analog Input Voltages	11-35
11.3.2	A/D Conversion by Successive Approximation Method	11-36
11.3.3	Comparator Operation	11-37
11.3.4	Calculating the A/D Conversion Time	11-38
11.3.5	Accuracy of A/D Conversion	11-43
11.4	Inflow Current Bypass Circuit	11-45
11.5	Notes on the A/D Converter	11-47

## CHAPTER 12 SERIAL INTERFACE

12.1	Outline of Serial Interface	12-2
12.2	Serial Interface Related Registers	12-5
12.2.1	SIO Interrupt Related Registers	12-6
12.2.2	SIO Transmit Control Registers	12-14
12.2.3	SIO Transmit/Receive Mode Registers	12-15
12.2.4	SIO Transmit Buffer Registers	12-19
12.2.5	SIO Receive Buffer Registers	12-20
12.2.6	SIO Receive Control Registers	12-21
12.2.7	SIO Baud Rate Registers	12-24
12.2.8	SIO Special Mode Registers	12-27
12.3	Transmit Operation in CSIO Mode	12-29
12.3.1	Setting the CSIO Baud Rate	12-29
12.3.2	Initializing CSIO Transmission	12-30
12.3.3	Starting CSIO Transmission	12-32
12.3.4	Successive CSIO Transmission	12-32
12.3.5	Processing at End of CSIO Transmission	12-33
12.3.6	Transmit Interrupts	12-33
12.3.7	Transmit DMA Transfer Request	12-33
12.3.8	Example of CSIO Transmit Operation	12-35
12.4	Receive Operation in CSIO Mode	12-37
12.4.1	Initialization for CSIO Reception	12-37
12.4.2	Starting CSIO Reception	12-39
12.4.3	Processing at End of CSIO Reception	12-39
12.4.4	About Successive Reception	12-40
12.4.5	Flags Showing the Status of CSIO Receive Operation	12-41
12.4.6	Example of CSIO Receive Operation	12-42
12.5	Notes on Using CSIO Mode	12-44
12.6	Transmit Operation in UART Mode	12-46
12.6.1	Setting the UART Baud Rate	12-46
12.6.2	UART Transmit/Receive Data Formats	12-46
12.6.3	Initializing UART Transmission	12-48
12.6.4	Starting UART Transmission	12-50
12.6.5	Successive UART Transmission	12-50
12.6.6	Processing at End of UART Transmission	12-50
12.6.7	Transmit Interrupts	12-50
12.6.8	Transmit DMA Transfer Request	12-51
12.6.9	Example of UART Transmit Operation	12-52
12.7	Receive Operation in UART Mode	12-54
12.7.1	Initialization for UART Reception	12-54
12.7.2	Starting UART Reception	12-56
12.7.3	Processing at End of UART Reception	12-56
12.7.4	Example of UART Receive Operation	12-58
12.7.5	Start Bit Detection and Data Sampling during UART Reception	12-60
12.8	Fixed Period Clock Output Function	12-61
12.9	Notes on Using UART Mode	12-62

## CHAPTER 13 CAN MODULE

13.1	Outline of the CAN Module	13-2
13.2	CAN Module Related Registers	13-4
13.2.1	CAN Bus Mode Control Register	13-23
13.2.2	CAN Control Registers	13-26
13.2.3	CAN Status Registers	13-29
13.2.4	CAN Configuration Registers	13-32
13.2.5	CAN Timestamp Count Registers	13-35
13.2.6	CAN Error Count Registers	13-36
13.2.7	CAN Baud Rate Prescalers	13-37
13.2.8	CAN Interrupt Related Registers	13-38
13.2.9	CAN Cause of Error Registers	13-67
13.2.10	CAN Mode Registers	13-69
13.2.11	CAN DMA Transfer Request Select Registers	13-70
13.2.12	CAN Message Slot Number Registers	13-71
13.2.13	CAN Clock Select Registers	13-72
13.2.14	CAN Frame Format Select Registers	13-74
13.2.15	CAN Mask Registers	13-76
13.2.16	CAN Single-Shot Mode Control Registers	13-80
13.2.17	CAN Message Slot Control Registers	13-82
13.2.18	CAN Message Slots	13-86
13.3	CAN Protocol	13-116
13.3.1	CAN Protocol Frames	13-116
13.3.2	Data Formats during CAN Transmission/Reception	13-117
13.3.3	CAN Controller Error States	13-118
13.4	Initializing the CAN Module	13-119
13.4.1	Initializing the CAN Module	13-119
13.5	Transmitting Data Frames	13-122
13.5.1	Data Frame Transmit Procedure	13-122
13.5.2	Data Frame Transmit Operation	13-123
13.5.3	Transmit Abort Function	13-124
13.6	Receiving Data Frames	13-125
13.6.1	Data Frame Receive Procedure	13-125
13.6.2	Data Frame Receive Operation	13-126
13.6.3	Reading Out Received Data Frames	13-128
13.7	Transmitting Remote Frames	13-130
13.7.1	Remote Frame Transmit Procedure	13-130
13.7.2	Remote Frame Transmit Operation	13-131
13.7.3	Reading Out Received Data Frames when Set for Remote Frame Transmission	13-133
13.8	Receiving Remote Frames	13-135
13.8.1	Remote Frame Receive Procedure	13-135
13.8.2	Remote Frame Receive Operation	13-136
13.9	Notes on CAN Module	13-139

## CHAPTER 14 DIRECT RAM INTERFACE (DRI)

14.1	Outline of the Direct RAM Interface (DRI)	14-2
14.2	DRI Related Registers	14-4
14.2.1	DD Input Pin Select Register	14-6
14.2.2	DRI Interrupt Related Registers	14-7
14.2.3	DRI Transfer Control Register	14-13
14.2.4	DRI Special Mode Control Register	14-15
14.2.5	DRI Data Capture Control Register	14-18
14.2.6	DRI Data Interleave Control Register	14-22
14.2.7	DD Input Event Select Register	14-22
14.2.8	DD Input Enable Registers	14-23
14.2.9	DRI Data Capture Event Count Setting Register	14-25
14.2.10	DRI Capture Event Counter	14-26
14.2.11	DRI Transfer Counter	14-27
14.2.12	DRI Address Counters	14-28
14.2.13	DRI Address Reload Registers	14-29
14.2.14	DIN Input Processing Control Register	14-30
14.2.15	DRI Event Counter (DEC) Control Registers	14-31
14.2.16	DRI Event Counters (DEC Counters)	14-36
14.2.17	DRI Event Counter (DEC) Reload Registers	14-36
14.3	Notes on DRI	14-37

## CHAPTER 15 REAL TIME DEBUGGER (RTD)

15.1	Outline of the Real-Time Debugger (RTD)	15-2
15.2	Pin Functions of the RTD	15-3
15.3	RTD Related Register	15-3
15.3.1	RTD Write Function Disable Register	15-3
15.4	Functional Description of the RTD	15-4
15.4.1	Outline of the RTD Operation	15-4
15.4.2	Operation of RDR (Real-time RAM Content Output)	15-4
15.4.3	Operation of the WRR (RAM Content Forcible Rewrite)	15-6
15.4.4	Operation of VER (Continuous Monitor)	15-7
15.4.5	Operation of VEI (Interrupt Request)	15-7
15.4.6	Operation of RCV (Recover from Runaway)	15-8
15.4.7	Method for Setting a Specified Address when Using the RTD	15-9
15.4.8	Resetting the RTD	15-10
15.5	Typical Connection with the Host	15-11

## CHAPTER 16 NON-BREAK DEBUG (NBD)

16.1	Outline of the Non-Break Debug (NBD)	16-2
16.2	Pin Functions of NBD	16-4
16.2.1	NBD Pin Control Register	16-4
16.3	NBD Related Registers	16-6
16.3.1	NBD Enable Register	16-6
16.4	Communication Protocol	16-7



16.5	RAM Monitor Function	16-8
16.5.1	Description of NBD Operation	16-8
16.5.2	NBDD Data Format	16-9
16.6	Event Detection Function	16-11
16.6.1	Event Address Setting Register	16-11
16.6.2	Event Condition Setting Register	16-12
16.6.3	Event Generation Register	16-12
CHAPTER 17 EXTERNAL BUS INTERFACE		
17.1	Outline of the External Bus Interface	17-2
17.1.1	External Bus Interface Related Signals	17-2
17.2	External Bus Interface Related Registers	17-5
17.2.1	Port Operation Mode and Port Peripheral Function Select Registers	17-5
17.2.2	Bus Mode Control Register	17-15
17.2.3	CLKOUT Select Register	17-16
17.3	Read/Write Operations	17-19
17.4	Bus Arbitration	17-25
17.5	Typical Connection of External Extension Memory	17-27
17.6	Example of Bus Voltage Settings Using VCC-BUS	17-30
CHAPTER 18 WAIT CONTROLLER		
18.1	Outline of the Wait Controller	18-2
18.2	Wait Controller Related Registers	18-4
18.2.1	CS Area Wait Control Registers	18-4
18.2.2	Flash E/W Wait Select Register	18-6
18.3	Typical Operation of the Wait Controller	18-7
CHAPTER 19 RAM BACKUP MODE		
19.1	Outline of RAM Backup Mode	19-2
19.2	Example of RAM Backup when Power is Off	19-3
19.2.1	Normal Operating State	19-3
19.2.2	RAM Backup State	19-4
19.3	Example of RAM Backup for Saving Power Consumption	19-5
19.3.1	Normal Operating State	19-6
19.3.2	RAM Backup State	19-7
19.3.3	Precautions to Be Observed at Power-On	19-8
19.3.4	Power-On Limitation	19-8
19.4	Exiting RAM Backup Mode (Wakeup)	19-9
CHAPTER 20 OSCILLATOR CIRCUIT		
20.1	Oscillator Circuit	20-2
20.1.1	Example of an Oscillator Circuit	20-2
20.1.2	XIN Oscillation Stoppage Detection Circuit	20-3
20.1.3	Oscillation Drive Capability Select Function	20-5
20.1.4	System Clock Output Function	20-7
20.1.5	Oscillation Stabilization Time at Power-On	20-11
20.2	Clock Generator Circuit	20-12



## CHAPTER 21 JTAG

21.1 Outline of JTAG	21-2
21.2 Configuration of JTAG Circuit	21-3
21.3 JTAG Registers	21-4
21.3.1 Instruction Register (JTAGIR)	21-4
21.3.2 Data Register	21-5
21.4 Basic Operation of JTAG	21-6
21.4.1 Outline of JTAG Operation	21-6
21.4.2 IR Path Sequence	21-8
21.4.3 DR Path Sequence	21-9
21.4.4 Inspecting and Setting Data Registers	21-10
21.5 Boundary Scan Description Language	21-11
21.6 Notes on Board Design when Connecting JTAG	21-12
21.7 Processing Pins when Not Using JTAG	21-13

## CHAPTER 22 POWER SUPPLY CIRCUIT

22.1 Configuration of the Power Supply Circuit	22-2
22.2 Power-On Sequence	22-3
22.2.1 Power-On Sequence when Not Using RAM Backup	22-3
22.2.2 Power-On Sequence when Using RAM Backup	22-4
22.3 Power-Off Sequence	22-5
22.3.1 Power-Off Sequence when Not Using RAM Backup	22-5
22.3.2 Power-Off Sequence when Using RAM Backup	22-6

## CHAPTER 23 ELECTRICAL CHARACTERISTICS

23.1 Adapted Table	23-2
23.2 Absolute Maximum Ratings	23-2
23.3 Electrical Characteristics when VCCE = 5 V, f(XIN) = 20 MHz	23-3
23.3.1 Recommended Operating Conditions (when VCCE = 5 V ± 0.5 V, f(XIN) = 20 MHz)	23-3
23.3.2 D.C. Characteristics (when VCCE = 5 V ± 0.5 V, f(XIN) = 20 MHz)	23-5
23.3.3 A/D Conversion Characteristics (when VCCE = 5 V ± 0.5 V, f(XIN) = 20 MHz)	23-6
23.4 Electrical Characteristics when VCCE = 5 V, f(XIN) = 16 MHz	23-7
23.4.1 Recommended Operating Conditions (when VCCE = 5 V ± 0.5 V, f(XIN) = 16 MHz)	23-7
23.4.2 D.C. Characteristics (when VCCE = 5 V ± 0.5 V, f(XIN) = 16 MHz)	23-9
23.4.3 A/D Conversion Characteristics (when VCCE = 5 V ± 0.5 V, f(XIN) = 16 MHz)	23-10
23.5 Electrical Characteristics when VCCE = 3.3 V, f(XIN) = 20 MHz	23-11
23.5.1 Recommended Operating Conditions (when VCCE = 3.3 V ± 0.3 V, f(XIN) = 20 MHz)	23-11
23.5.2 D.C. Characteristics (when VCCE = 3.3 V ± 0.3 V, f(XIN) = 20 MHz)	23-13
23.5.3 A/D Conversion Characteristics (when VCCE = 3.3 V ± 0.3 V, f(XIN) = 20 MHz)	23-14
23.6 Electrical Characteristics when VCCE = 3.3 V, f(XIN) = 16 MHz	23-15
23.6.1 Recommended Operating Conditions (when VCCE = 3.3 V ± 0.3 V, f(XIN) = 16 MHz)	23-15
23.6.2 D.C. Characteristics (when VCCE = 3.3 V ± 0.3 V, f(XIN) = 16 MHz)	23-17
23.6.3 A/D Conversion Characteristics (when VCCE = 3.3 V ± 0.3 V, f(XIN) = 8 MHz)	23-18
23.7 Flash Memory Related Characteristics	23-19
23.8 External Capacitance for Power Supply	23-19
23.9 A.C. Characteristics (when VCCE = 5 V)	23-20
23.10 A.C. Characteristics (when VCCE = 3.3 V)	23-42

## APPENDIX 1 MECHANICAL SPECIFICATIONS

Appendix 1.1 Dimensional Outline Drawing .....	Appendix 1-2
--	--------------

## APPENDIX 2 INSTRUCTION PROCESSING TIME

Appendix 2.1 32192/32195/32196 Instruction Processing Time .....	Appendix 2-2
--	--------------

## APPENDIX 3 PROCESSING OF UNUSED PINS

Appendix 3.1 Example Processing of Unused Pins .....	Appendix 3-2
--	--------------

## APPENDIX 4 SUMMARY OF PRECAUTIONS

Appendix 4.1 Notes on the CPU .....	Appendix 4-2
Appendix 4.2 Notes on Address Space .....	Appendix 4-3
Appendix 4.3 Notes on EIT .....	Appendix 4-3
Appendix 4.4 Notes on the Internal RAM .....	Appendix 4-3
Appendix 4.5 Notes on the Internal Flash Memory .....	Appendix 4-4
Appendix 4.6 Things to Be Considered upon Exiting Reset .....	Appendix 4-4
Appendix 4.7 Notes on Input/Output Ports .....	Appendix 4-5
Appendix 4.8 Notes on the DMAC .....	Appendix 4-6
Appendix 4.9 Notes on Multijunction Timers .....	Appendix 4-7
Appendix 4.9.1 Notes on using TOP single-shot output mode .....	Appendix 4-7
Appendix 4.9.2 Notes on using TOP delayed single-shot output mode .....	Appendix 4-9
Appendix 4.9.3 Notes on using TOP continuous output mode .....	Appendix 4-10
Appendix 4.9.4 Notes on using TIO measure free-run/ clear input modes .....	Appendix 4-10
Appendix 4.9.5 Notes on using TIO PWM output mode .....	Appendix 4-10
Appendix 4.9.6 Notes on using TIO single-shot output mode .....	Appendix 4-10
Appendix 4.9.7 Notes on using TIO delayed single-shot output mode .....	Appendix 4-11
Appendix 4.9.8 Notes on using TIO continuous output mode .....	Appendix 4-11
Appendix 4.9.9 Notes on using TMS measure input .....	Appendix 4-11
Appendix 4.9.10 Notes on using TML measure input .....	Appendix 4-12
Appendix 4.9.11 Notes on using TOU PWM output mode .....	Appendix 4-13
Appendix 4.9.12 Notes on using TOU single-shot PWM output mode .....	Appendix 4-16
Appendix 4.9.13 Notes on using TOU delayed single-shot output mode .....	Appendix 4-16
Appendix 4.9.14 Notes on using TOU single-shot output mode .....	Appendix 4-16
Appendix 4.9.15 Notes on using TOU continuous output mode .....	Appendix 4-17
Appendix 4.9.16 0% or 100% Duty-Cycle Wave Output during PWM Output and Single-shot PWM Output Modes .....	Appendix 4-17
Appendix 4.10 Notes on the A/D Converter .....	Appendix 4-22
Appendix 4.11 Notes on Serial Interface .....	Appendix 4-25
Appendix 4.11.1 Notes on Using CSIO Mode .....	Appendix 4-25
Appendix 4.11.2 Notes on Using UART Mode .....	Appendix 4-26
Appendix 4.12 Notes on CAN Module .....	Appendix 4-28
Appendix 4.13 Notes on DRI .....	Appendix 4-29
Appendix 4.14 Notes on RAM Backup Mode .....	Appendix 4-29
Appendix 4.14.1 Precautions to Be Observed at Power-On .....	Appendix 4-29
Appendix 4.14.2 Power-On Limitation .....	Appendix 4-29

Appendix 4.15 Notes on JTAG .....	Appendix 4-30
Appendix 4.15.1 Notes on Board Design when Connecting JTAG .....	Appendix 4-30
Appendix 4.15.2 Processing Pins when Not Using JTAG .....	Appendix 4-31
Appendix 4.16 Notes on Noise .....	Appendix 4-32
Appendix 4.16.1 Reduction of Wiring Length .....	Appendix 4-32
Appendix 4.16.2 Inserting a Bypass Capacitor between VSS and VCC Lines .....	Appendix 4-34
Appendix 4.16.3 Processing Analog Input Pin Wiring .....	Appendix 4-34
Appendix 4.16.4 Consideration about the Oscillator .....	Appendix 4-35
Appendix 4.16.5 Processing Input/Output Ports .....	Appendix 4-39

To be written at a later time.

# CHAPTER 1

---

## OVERVIEW

- 1.1 Outline of the 32192/32195/32196 Group
- 1.2 Block Diagram
- 1.3 Pin Functions
- 1.4 Pin Assignments

## 1.1 Outline of the 32192/32195/32196 Group

The 32192/32195/32196 Group (hereinafter simply the 32192/32195/32196) belongs to the M32R/ECU Series in the M32R Family of Renesas microcomputers. For details about the current development status of the 32192/32195/32196, please contact your nearest office of Renesas or its distributor.

**Table 1.1.1 Product List**

Type Name	ROM capacity	RAM capacity	Frequency	Power supply voltage		Temperature Range (Note 1)
				at single-supply	at double-supply	
M32192F8VFP	1 Mbytes	176 Kbytes	128 MHz	3.3V	5V, 3.3V	-40°C to 125°C
M32192F8UFP	1 Mbytes	176 Kbytes	160 MHz	3.3V	5V, 3.3V	-40°C to 105°C
M32192F8TFP	1 Mbytes	176 Kbytes	160 MHz	5V or 3.3V	5V, 3.3V	-40°C to 85°C
M32192F8VWG	1 Mbytes	176 Kbytes	128 MHz	3.3V	5V, 3.3V	-40°C to 125°C
M32192F8UWG	1 Mbytes	176 Kbytes	160 MHz	3.3V	5V, 3.3V	-40°C to 105°C
M32192F8TWG	1 Mbytes	176 Kbytes	160 MHz	5V or 3.3V	5V, 3.3V	-40°C to 85°C
M32195F4VFP	512 Kbytes	32 Kbytes	128 MHz	3.3V	5V, 3.3V	-40°C to 125°C
M32195F4UFP	512 Kbytes	32 Kbytes	160 MHz	3.3V	5V, 3.3V	-40°C to 105°C
M32195F4TFP	512 Kbytes	32 Kbytes	160 MHz	5V or 3.3V	5V, 3.3V	-40°C to 85°C
M32196F8VFP	1 Mbytes	64 Kbytes	128 MHz	3.3V	5V, 3.3V	-40°C to 125°C
M32196F8UFP	1 Mbytes	64 Kbytes	160 MHz	3.3V	5V, 3.3V	-40°C to 105°C
M32196F8TFP	1 Mbytes	64 Kbytes	160 MHz	5V or 3.3V	5V, 3.3V	-40°C to 85°C

Note 1: This does not guarantee continuous operation and there is a limitation on the length of use (temperature profile).

### 1.1.1 M32R Family CPU Core with Built-in FPU (M32R-FPU)

#### (1) Based on a RISC architecture

- The 32192/32195/32196 is a group of 32-bit RISC single-chip microcomputers. The M32R-FPU in this group of microcomputers incorporates a fully IEEE 754-compliant, single-precision FPU in order to materialize the common instruction set and the high-precision arithmetic operation of the M32R CPU. The 32192/32195/32196 products listed in the above table are built around the M32R-FPU and incorporates flash memory, RAM and various peripheral functions, all integrated into a single chip.
- The M32R-FPU is constructed based on a RISC architecture. Memory is accessed using load/store instructions, and various arithmetic/logic operations are executed using register-to-register operation instructions.
- The M32R-FPU internally contains sixteen 32-bit general-purpose registers. The instruction set consists of 100 discrete instructions in total (83 instructions common to the M32R Family plus 17 FPU and extended instructions). These instructions are either 16 bits or 32 bits long.
- In addition to the ordinary load/store instructions, the M32R-FPU supports compound instructions such as Load & Address Update and Store & Address Update. These instructions help to speed up data transfers.

#### (2) Six-stage pipelined processing

- The M32R-FPU supports six-stage pipelined instruction processing. Not just load/store instructions and register-to-register operation instructions, but also floating-point arithmetic instructions and compound instructions such as Load & Address Update and Store & Address Update are executed in one CPUCLK period (which is equivalent to 6.25 ns when  $f(\text{CPUCLK}) = 160 \text{ MHz}$ ).
- Although instructions are supplied to the execution stage in the order in which they were fetched, it is possible that if the load/store instruction supplied first is extended by wait cycles inserted in memory access, the subsequent register-to-register operation instruction will be executed before that instruction. Using such a facility, which is known as the "out-of-order-completion" mechanism, the M32R-FPU is able to control instruction execution without wasting clock cycles.

### (3) Compact instruction code

- The M32R-FPU supports two instruction formats: one 16 bits long, and one 32 bits long. Use of the 16-bit instruction format especially helps to suppress the code size of a program.
- Moreover, the availability of 32-bit instructions makes programming easier and provides higher performance at the same clock speed than in architectures where the address space is segmented. For example, some 32-bit instructions allow control to jump to an address 32 Mbytes forward or backward from the currently executed address in one instruction, making programming easy.

## 1.1.2 Built-in Multiplier/Accumulator

### (1) Built-in high-speed multiplier

- The M32R-FPU contains a 32 bits × 16 bits high-speed multiplier which enables the M32R-FPU to execute a 32 bits × 32 bits integral multiplication instruction in three CPUCLK periods.

### (2) DSP-comparable multiply-accumulate instructions

- The M32R-FPU supports the following four types of multiply-accumulate instructions (or multiplication instructions) which each can be executed in one CPUCLK period using a 56-bit accumulator.
  - (1) 16 high-order bits of register × 16 high-order bits of register
  - (2) 16 low-order bits of register × 16 low-order bits of register
  - (3) All 32 bits of register × 16 high-order bits of register
  - (4) All 32 bits of register × 16 low-order bits of register
- The M32R-FPU has some special instructions to round the value stored in the accumulator to 16 or 32 bits or shift the accumulator value before storing in a register to have its digits adjusted. Because these instructions too are executed in one CPUCLK period, when used in combination with high-speed data transfer instructions such as Load & Address Update or Store & Address Update, they enable the M32R-FPU to exhibit superior data processing capability comparable to that of a DSP.

## 1.1.3 Built-in Single-precision FPU

- The M32R-FPU supports single-precision floating-point arithmetic fully compliant with IEEE 754 standards. Specifically, five exceptions specified in IEEE 754 standards (Inexact, Underflow, Division by Zero, Overflow and Invalid Operation) and four rounding modes (round to nearest, round toward 0, round toward + Infinity and round toward – Infinity) are supported. What's more, because general-purpose registers are used to perform floating-point arithmetic, the overhead associated with transferring the operand data can be reduced.

## 1.1.4 Built-in Flash Memory and RAM

- The 32192/32195/32196 contains a RAM that can be accessed with zero wait state, allowing to design a high-speed embedded system.
- The internal flash memory can be written to while mounted on a printed circuit board (on-board writing). Use of flash memory facilitates development work, because the chip used at the development stage can be used directly in mass-production, allowing for a smooth transition from prototype to mass-production without the need to change the printed circuit board.
- The internal flash memory can be rewritten as many as 100 times.

- The internal flash memory has a virtual flash emulation function, allowing the internal RAM to be superficially mapped into part of the internal flash memory. When combined with the internal Real-Time Debugger (RTD) and the M32R family's common debug interface (Scalable Debug Interface or SDI), this function makes the ROM table data tuning easy.
- The internal RAM can be accessed for reading or rewriting data from an external device independently of the M32R-FPU by using the Real-Time Debugger. The external device is communicated using the Real-Time Debugger's exclusive clock-synchronous serial interface.



### 1.1.5 Built-in Clock Frequency Multiplier

- The 32192/32195/32196 contains a clock frequency multiplier, which is schematically shown in Figure 1.1.1 below.

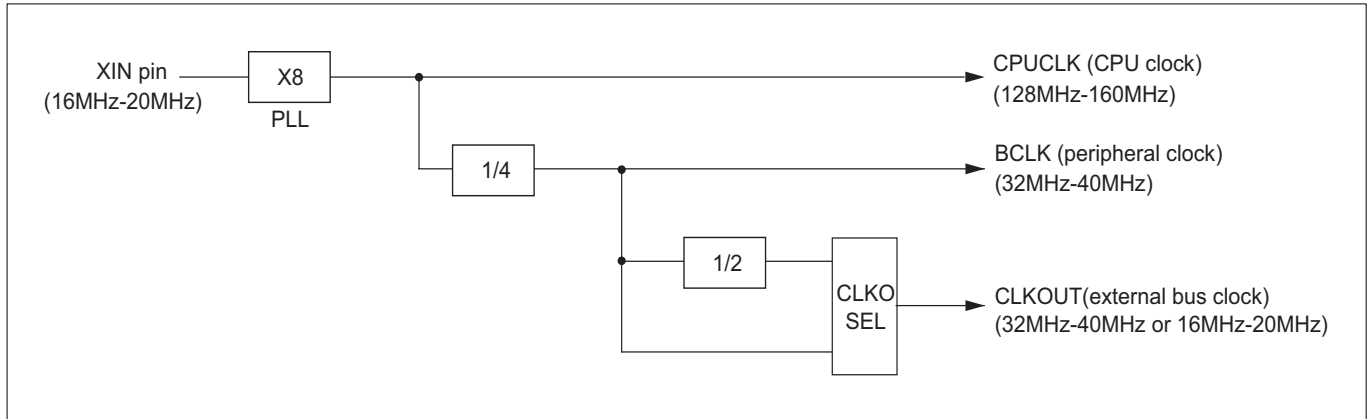


Figure 1.1.1 Conceptual Diagram of the Clock Frequency Multiplier

Table 1.1.2 Clock

Functional Block	Features
CPUCLK	<ul style="list-style-type: none"> <li>CPU clock: Defined as <math>f(\text{CPUCLK})</math> when it indicates the operating clock frequency for the M32R-FPU core, internal flash memory and internal RAM.</li> </ul>
BCLK	<ul style="list-style-type: none"> <li>Peripheral clock: Defined as <math>f(\text{BCLK})</math> when it indicates the operating clock frequency for the internal peripheral I/O and external data bus.</li> </ul>
Clock output	<ul style="list-style-type: none"> <li>BCLK pin output: A clock with the same frequency as <math>f(\text{BCLK})</math> is output from this pin.</li> <li>CLKOUT pin output: A clock with the same or half frequency as <math>f(\text{BCLK})</math> is output from this pin.</li> </ul>

### 1.1.6 Powerful Peripheral Functions Built-in

- 8-level interrupt controller (ICU)
- 10-channel DMAC
- 55-channel multijunction timer (MJT)
- 16-channel A/D converter (ADC)
- 6-channel serial interface (SIO)
- 2-channel Full-CAN
- Direct RAM interface (DRI)
- Real-time debugger (RTD)
- Non-break debug (NBD)
- Wait controller
- M32R Family's common debug function (Scalable Debug Interface or SDI)

## 1.2 Block Diagram

Figure 1.2.1 shows a block diagram of the 32192/32195/32196. The features of each block are described in Table 1.2.1.

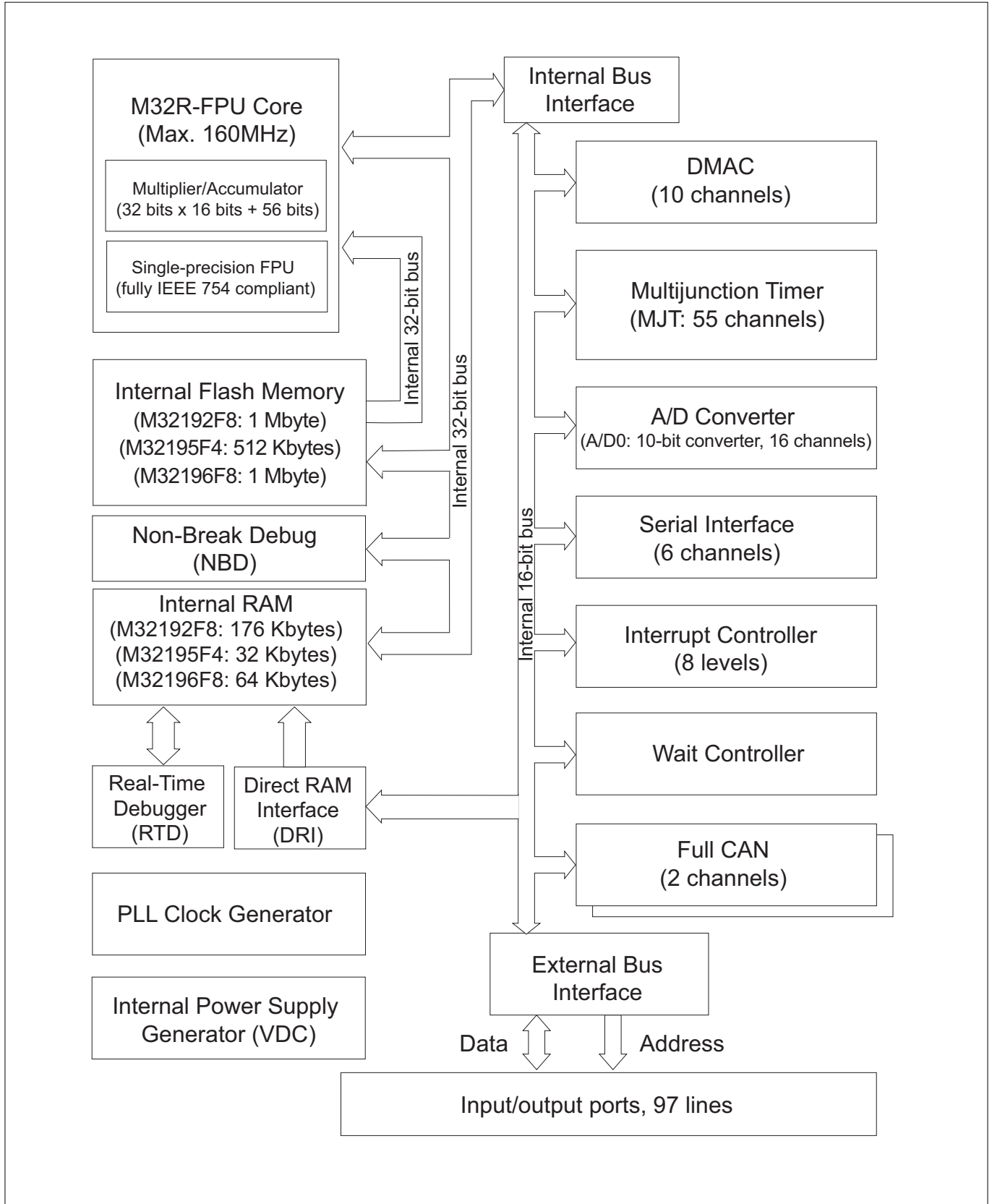


Figure 1.2.1 Block Diagram of the 32192/32195/32196

Table 1.2.1 Features of the 32192/32195/32196 (1/3)

Functional Block	Features
M32R-FPU CPU core	<ul style="list-style-type: none"> <li>• Implementation: Six-stage pipelined instruction processing</li> <li>• Internal 32-bit structure of the core</li> <li>• Register configuration <ul style="list-style-type: none"> <li>General-purpose registers: 32 bits × 16 registers</li> <li>Control registers: 32 bits × 6 registers</li> </ul> </li> <li>• Instruction set <ul style="list-style-type: none"> <li>16-bit and 32-bit instruction formats</li> <li>100 discrete instructions and six addressing modes</li> </ul> </li> <li>• Internal multiplier/accumulator (32 bits × 16 bits + 56 bits)</li> <li>• Internal single-precision floating-point arithmetic unit (FPU)</li> </ul>
Internal Flash memory	<ul style="list-style-type: none"> <li>• Capacity: <ul style="list-style-type: none"> <li>M32192F8 : 1 Mbyte</li> <li>M32195F4 : 512 Kbytes</li> <li>M32196F8 : 1 Mbyte</li> </ul> </li> <li>• One wait access</li> <li>• Durability: Rewritable 100 times</li> </ul>
Internal RAM	<ul style="list-style-type: none"> <li>• Capacity: <ul style="list-style-type: none"> <li>M32192F8 : 176 Kbytes</li> <li>M32195F4 : 32 Kbytes</li> <li>M32196F8 : 64 Kbytes</li> </ul> </li> <li>• Zero wait access</li> <li>• The internal RAM can be accessed for reading or rewriting data from the outside independently of the M32R-FPU by using the Real-Time Debugger, without ever causing the CPU performance to decrease.</li> <li>• By using RAM backup mode, a part of internal RAM area can be backed up when turn off the power supply.</li> </ul>
Bus specification	<ul style="list-style-type: none"> <li>• Fundamental bus cycle: 6.25 ns (when f(CPUCLK) = 160 MHz)</li> <li>• Logical address space : 4 Gbytes linear</li> <li>• Internal bus specification : Internal 32-bit data bus (for CPU &lt;-&gt; internal flash memory and RAM access) <ul style="list-style-type: none"> <li>(or accessed in 64 bits when accessing the internal flash memory for instructions)</li> <li>: Internal 16-bit data bus (for internal peripheral I/O access)</li> </ul> </li> <li>• External extension area: During processor mode: maximum 32 Mbytes <ul style="list-style-type: none"> <li>During external extension mode: maximum 31 Mbytes</li> <li>(7 Mbytes + 8 Mbytes × 3 blocks)</li> </ul> </li> <li>• External data address: 22-bit address</li> <li>• External data bus: 16-bit data bus</li> <li>• Shortest external bus access: 1 CLKOUT during read, 1 CLKOUT during write</li> </ul>
Multijunction timer (MJT)	<ul style="list-style-type: none"> <li>• 55-channel multi-functional timer <ul style="list-style-type: none"> <li>16-bit output related timer × 11 channels, 16-bit input/output related timer × 10 channels,</li> <li>16-bit input related timer × 8 channels, 32-bit input related timer × 8 channels,</li> <li>16-bit input related up/down timer × 2 channels, and 24-bit output related timer × 16 channels</li> </ul> </li> <li>• Flexible timer configuration is possible by interconnecting these timer channels.</li> <li>• Interrupt request: Counter underflow or overflow and rising or falling or both edges or “H” or “L” level from the TIN pin (TIN pin can be used as external interrupt inputs irrespective of timer operation.)</li> <li>• DMA transfer request: Counter underflow or overflow and rising or falling or both edges or “H” or “L” level from the TIN pin (TIN pin can be used as DMA transfer request inputs irrespective of timer operation.)</li> </ul>
DMAC	<ul style="list-style-type: none"> <li>• Number of channels: 10</li> <li>• Transfers between internal peripheral I/Os or internal RAMs or between internal peripheral I/O and internal RAM are supported.</li> <li>• Capable of advanced DMA transfers when used in combination with internal peripheral I/O</li> <li>• Transfer request: Software or internal peripheral I/O (A/D converter, MJT, serial interface or CAN)</li> <li>• DMA channels can be cascaded. (DMA transfer on a channel can be started by completion of a transfer on another channel.)</li> <li>• Interrupt request: DMA transfer counter register underflow</li> </ul>

Table 1.2.1 Features of the 32192/32195/32196 (2/3)

Functional Block	Features
A/D Converter (ADC)	<ul style="list-style-type: none"> <li>• 16 channels: 10-bit resolution A/D converter × 1 block</li> <li>• Conversion modes: In addition to ordinary A/D conversion mode, comparator mode and 2-channel simultaneous sampling mode.</li> <li>• Operation modes: Single conversion mode and n-channel scan mode (n = 1–16)</li> <li>• Sample-and-hold function: Performs A/D conversion with the analog input voltages sampled at start of A/D conversion.</li> <li>• A/D disconnection detection assist function: Suppresses effects of the analog input voltage leakage from the preceding channel during A/D conversion.</li> <li>• An inflow current bypass circuit is built-in.</li> <li>• Can generate an interrupt or start DMA transfer upon completion of A/D conversion.</li> <li>• Either 8-bit or 10-bit conversion results can be read out.</li> <li>• Interrupt request: Completion of A/D conversion</li> <li>• DMA transfer request: Completion of A/D conversion</li> </ul>
Serial Interface (SIO)	<ul style="list-style-type: none"> <li>• 6-channel serial interface</li> <li>• Can be chosen to be clock-synchronous serial interface or clock-asynchronous serial interface.</li> <li>• Data can be transferred at high speed (5 Mbits per second during clock-synchronous mode or 2.5 Mbits per second during clock-asynchronous mode when f(BCLK) = 40 MHz).</li> <li>• Interrupt request: Reception completed, receive error, transmit buffer empty or transmission completed</li> <li>• DMA transfer request: Reception completed or transmit buffer empty</li> </ul>
CAN	<ul style="list-style-type: none"> <li>• 32 message slots × 2 blocks</li> <li>• Compliant with CAN specification 2.0B active.</li> <li>• Interrupt request: Transmission completed, reception completed, bus error, error-passive, bus-off or single shot</li> <li>• DMA transfer request: Failed to send, transmission completed or reception completed</li> </ul>
Real-Time Debugger (RTD)	<ul style="list-style-type: none"> <li>• Internal RAM can be rewritten or monitored independently of the CPU by entering a command from the outside.</li> <li>• Comes with exclusive clock-synchronous serial ports.</li> <li>• Interrupt request: RTD interrupt command input</li> </ul>
Non-Break Debug (NBD)	<ul style="list-style-type: none"> <li>• Can access to all resources on the address map from the outside</li> <li>• Clock-synchronous parallel interface (4-bit)</li> <li>• Event output function</li> <li>• RAM monitor function</li> </ul>
Direct RAM Interface (DRI)	<ul style="list-style-type: none"> <li>• Can control capture of clock-synchronous parallel data to the internal RAM independently of the CPU</li> <li>• Clock-synchronous parallel input (8-bit, 16-bit or 32-bit)</li> <li>• Maximum transfer rate: 40 Mbytes/s (when f(CPUCLK)=160 MHz)</li> </ul>
Interrupt Controller (ICU)	<ul style="list-style-type: none"> <li>• Controls interrupt requests from the internal peripheral I/O.</li> <li>• Supports 8-level interrupt priority including an interrupt disabled state.</li> <li>• External interrupt: 27 sources (SBI#, TIN0, TIN3–TIN11, TIN16–TIN27, TIN30–TIN33)</li> <li>• TIN pin input sensing: Rising, falling or both edges or "H" or "L" level</li> </ul>
Wait Controller	<ul style="list-style-type: none"> <li>• Controls wait states for access to the external extension area.</li> <li>• Insertion of 0–15 wait states by setting up in software + wait state extension by entering WAIT# signal</li> </ul>
PLL	<ul style="list-style-type: none"> <li>• A multiply-by-8 clock generating circuit</li> </ul>
Clock	<ul style="list-style-type: none"> <li>• Maximum external input clock frequency (XIN) is 20.0 MHz. (Note 1)</li> <li>• CPUCLK: Operating clock for the M32R-FPU core, internal flash memory and internal RAM The maximum CPU clock is 160 MHz (when f(XIN) = 20 MHz).</li> <li>• BCLK: Operating clock for the internal peripheral I/O and external data bus The maximum peripheral clock is 40 MHz (peripheral module access when f(XIN) = 20 MHz).</li> <li>• BCLK pin output: A clock with the same frequency as f(BCLK) is output from this pin.</li> <li>• CLKOUT pin output: A clock with the same or half frequency as f(BCLK) is output from this pin.</li> </ul>

Table 1.2.1 Features of the 32192/32195/32196 (3/3)

Functional Block	Features
JTAG	<ul style="list-style-type: none"><li>• Boundary scan function</li></ul>
VDC	<ul style="list-style-type: none"><li>• Internal power supply generating circuit: Generates the internal power supply from an external power supply (5 or 3.3 V).</li></ul>
Ports	<ul style="list-style-type: none"><li>• Input/output pin: 97 pins</li><li>• The port input threshold can be set in a program to one of three levels individually for each port group (with or without Schmitt circuit, selectable).</li></ul>

Note 1: The maximum external input clock frequency (XIN) for the M32192F8VFP, M32195F4VFP, and M32196F8VFP are 16.0 MHz.

1.3 Pin Functions

Figure 1.3.1 and Figure 1.3.2 show the 32192/32195/32196's pin function diagram. Pin functions are described in Table 1.3.1.

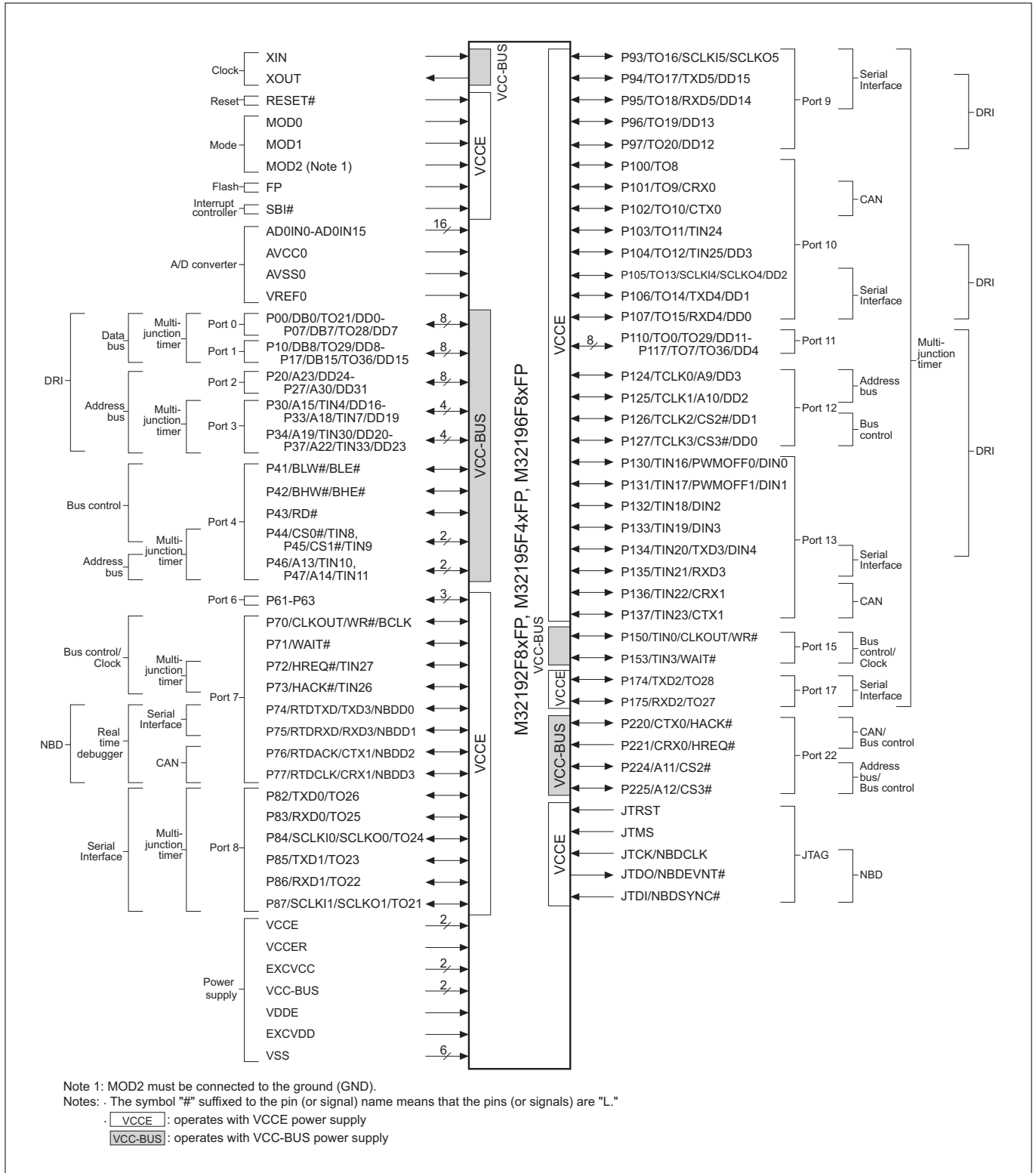


Figure 1.3.1 Pin Function Diagram (144pin LQFP)

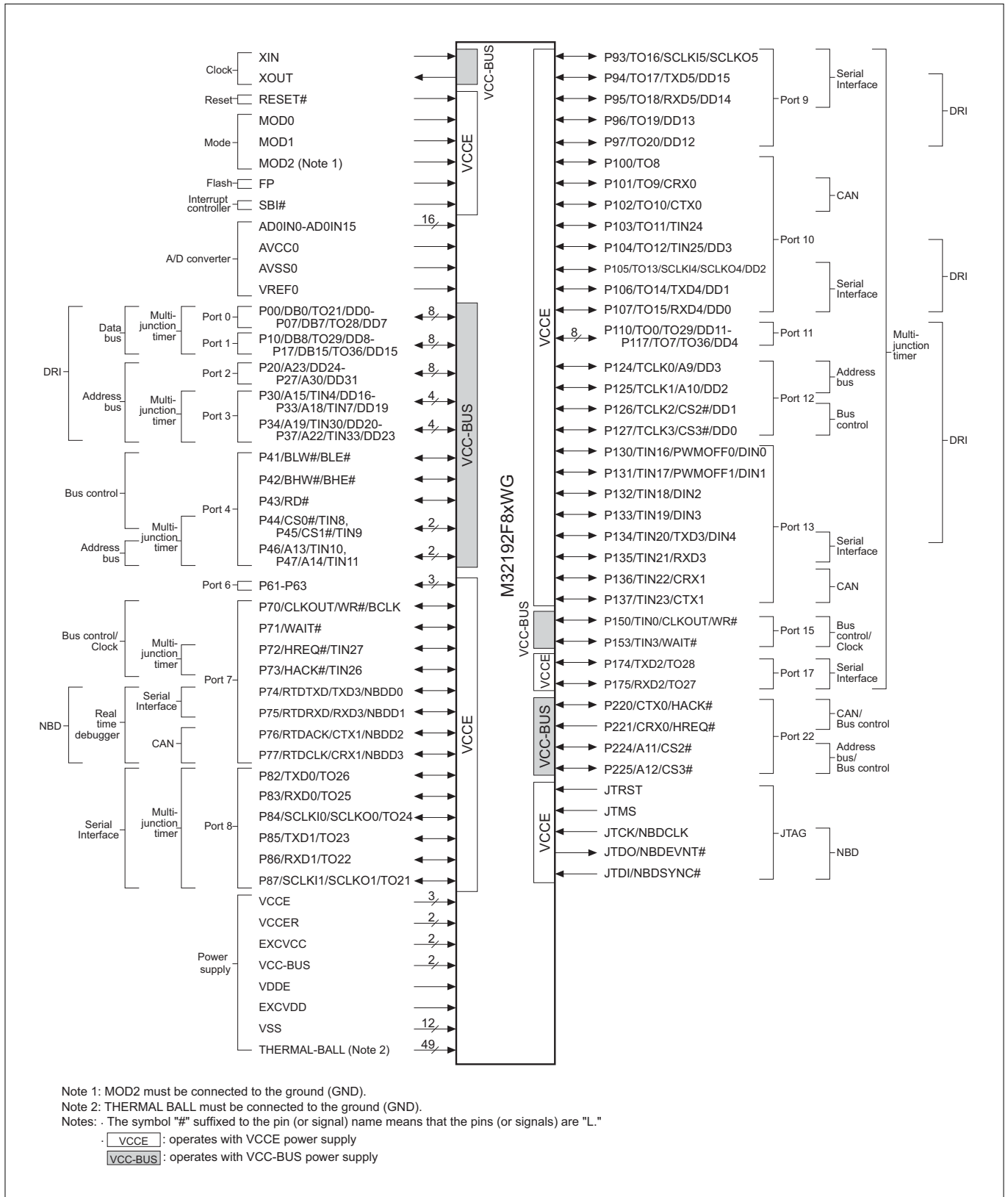


Figure 1.3.2 Pin Function Diagram (224pin FBGA)

Table 1.3.1 Description of Pin Functions (1/3)

Type	Pin Name	Signal Name	Input/Output	Description			
Power supply	VCCER	Internal power supply input	–	Power supply input for the internal voltage generator circuit (5.0 V ± 0.5 V or 3.3 V ± 0.3 V).			
	VCCE	Port/internal peripheral I/O pin power supply input	–	Power supply input for the port and internal peripheral I/O pins (5.0 V ± 0.5 V or 3.3 V ± 0.3 V). Apply same voltage to the all VCCE pins.			
	VCC-BUS	Port/bus interface pin power supply input	–	Power supply input for the port and bus interface pins (5.0 V ± 0.5 V or 3.3 V ± 0.3 V). Apply same voltage to the all VCC-BUS pins.			
	VDDE	RAM power supply input	–	Backup power supply input for the internal RAM (5.0 V ± 0.5 V or 3.3 V ± 0.3 V).			
	VSS	Ground	–	Connect all VSS pins to ground (GND).			
	THERMAL-BALL(Note 2)	THERMAL BALL	–	Connect THERMAL BALL to the ground (GND).			
	EXCVCC	VCCER control	–	This pin connects an external capacitor for the internal voltage generator circuit.			
	EXCVDD	VDDE control	–	This pin connects an external capacitor for the internal power supply of the internal RAM.			
Clock	XIN, XOUT	Clock input Clock output	Input Output	These are clock input/output pins. Including a PLL-based x8 frequency multiplier, they input 1/8 of the CPU clock frequency. (XIN input is 20 MHz when f(CPUCLK) = 160 MHz.)			
	CLKOUT, BCLK	System clock	Output	The CLKOUT pin outputs a clock that is equal to the external input clock frequency, XIN (i.e., CLKOUT output is 20 MHz when f(CPUCLK) = 160 MHz), or two times of XIN (i.e., CLKOUT output is 40 MHz when f(CPUCLK) = 160 MHz). (It is used when operating synchronous setting in external) This clock is used when operations are synchronous external to the chip. The BCLK pin outputs a clock that is two times the external input clock frequency, XIN (i.e., BCLK output is 40 MHz when f(CPUCLK) = 160 MHz).			
	RESET#	Reset	Input	Reset input pin for the internal circuit.			
Mode	MOD0– MOD2	Mode	Input	Set the microcomputer's operation mode.			
				MOD0	MOD1	MOD2	Mode
				L	L	L	Single-chip mode
				L	H	L	External extension mode
				H	L	L	Processor mode (boot mode) (Note 1)
				H	H	L	(Settings inhibited)
X	X	H	(Settings inhibited)				
X: Don't care							
Flash protect	FP	Flash protect	Input	This special pin protects the flash memory against rewrites in hardware.			
Address bus	A9–A30	Address bus	Output	Twenty-two address lines (A9–A30) are included, allowing four blocks each up to 8 Mbyte memory space to be connected external to the chip. A31 is not output.			

Note 1: Boot mode requires that the FP pin should be at the “H” level. For details about boot mode, see Chapter 6, “Internal Memory.”

Note 2: THERMAL BALL has a pin only in the M32192F8xWG.



Table 1.3.1 Description of Pin Functions (2/3)

Type	Pin Name	Signal Name	Input/Output	Description
Data bus	DB0–DB15	Data bus	Input/output	This 16-bit data bus is used to connect external devices. When writing in byte units during a write cycle, the output data at the invalid byte position is undefined. During a read cycle, data on the entire 16-bit bus is always read in. However, only the data at the valid byte position is transferred into the internal circuit.
Bus control	CS0#–CS3#	Chip select	Output	These are chip select signals for external devices.
	RD#	Read	Output	This signal is output when reading an external device.
	WR#	Write	Output	This signal is output when writing to an external device.
	BHW#/BLW#	Byte high/low write	Output	When writing to an external device, this signal indicates the valid byte position to which data is transferred. BHW# and BLW# correspond to the upper address side (bits 0–7 are valid) and the lower address side (bits 8–15 are valid), respectively.
	BHE#	Byte high enable	Output	During an external device access, this signal indicates that the high-order data (bits 0–7) is valid.
	BLE#	Byte low enable	Output	During an external device access, this signal indicates that the low-order data (bits 8–15) is valid.
	WAIT#	Wait	Input	When accessing an external device, a “L” level input on WAIT# pin extends the wait cycle.
	HREQ#	Hold request	Input	This input pin is used by an external device to request control of the external bus. A “L” level input on HREQ# pin places the CPU in a hold state.
Multijunction timer	HACK#	Hold acknowledge	Output	This signal notifies that the CPU has entered a hold state and relinquished control of the external bus.
	TIN0, TIN3–TIN11, TIN16–TIN27, TIN30–TIN33	Timer input	Input	Input pins for the multijunction timer.
	TO0–TO36	Timer output	Output	Output pins for the multijunction timer.
	TCLK0–TCLK3	Timer clock	Input	Clock input pins for the multijunction timer.
A/D converter	AVCC0	Analog power supply input	–	AVCC0 is the power supply input for the A/D0 converter. Connect AVCC0 to the power supply rail.
	AVSS0	Analog ground	–	AVSS0 is the analog ground for the A/D0 converter. Connect AVSS0 to ground.
	AD0IN0–AD0IN15	Analog input	Input	16-channel analog input pins for the A/D0 converter.
	VREF0	Reference voltage input	Input	VREF0 is the reference voltage input pin for the A/D0 converter.
Interrupt controller	SBI#	System break interrupt	Input	This is the system break interrupt (SBI) input pin for the interrupt controller.
Serial interface	SCLKI0/SCLKO0, SCLKI1/SCLKO1, SCLKI4/SCLKO4, SCLKI5/SCLKO5	UART transmit/receive clock output or CSIO transmit/receive clock input/output	Input/output	When channel is in UART mode: This pin outputs a clock derived from BRG output by dividing it by 2. When channel is in CSIO mode: This pin inputs a transmit/receive clock when external clock is selected or outputs a transmit/receive clock when internal clock is selected.

Table 1.3.1 Description of Pin Functions (3/3)

Type	Pin Name	Signal Name	Input/Output	Description
Serial interface	TXD0–TXD5	Transmit data	Output	Transmit data output pin for serial interface.
	RXD0–RXD5	Received data	Input	Received data input pin for serial interface.
Real-time debugger (RTD)	RTDTXD	RTD transmit data	Output	Serial data output pin for the real-time debugger.
	RTDRXD	RTD received data	Input	Serial data input pin for the real-time debugger.
	RTDCLK	RTD clock input	Input	Serial data transmit/receive clock input pin for the real-time debugger.
	RTDACK	RTD acknowledge	Output	A “L” level pulse is output from this pin synchronously with the start clock for the real-time debugger’s serial data output word. The “L” level pulse width indicates the type of command/data received by the real-time debugger.
CAN	CTX0, CTX1	Transmit data	Output	This pin outputs data from the CAN module.
	CRX0, CRX1	Received data	Input	This pin inputs the data for the CAN module.
JTAG	JTMS	Test mode select	Input	Test mode select input to control the state transition of the test circuit.
	JTCK	Test clock	Input	Clock input for the debug module and test circuit.
	JTRST	Test reset	Input	Test reset input to initialize the test circuit asynchronously with device operation.
	JTDI	Test data input	Input	This pin inputs the test instruction code or test data that is serially received.
	JTDO	Test data output	Output	This pin outputs the test instruction code or test data serially.
NBD	NBDD0–NBDD3	Command/Address/Data	Input/output	NBD command, address, and data input/output pins.
	NBDCLK	Synchronous clock input	Input	NBD synchronous clock input pin.
	NBDSYNC#	Top of data input	Input	Input pin to control the start position of NBD data.
	NBDEVNT#	Event output	Output	Output pin used for event output when an NBD event occurs.
DRI	DD0–DD31	DD input	Input	DRI data input pin.
	DIN0–DIN4	DIN input	Input	DRI event input pin.
Input/output ports (Note 1)	P00–P07	Input/output port 0	Input/output	Programmable input/output port.
	P10–P17	Input/output port 1	Input/output	
	P20–P27	Input/output port 2	Input/output	
	P30–P37	Input/output port 3	Input/output	
	P41–P47	Input/output port 4	Input/output	
	P61–P63	Input/output port 6	Input/output	
	P70–P77	Input/output port 7	Input/output	
	P82–P87	Input/output port 8	Input/output	
	P93–P97	Input/output port 9	Input/output	
	P100–P107	Input/output port 10	Input/output	
	P110–P117	Input/output port 11	Input/output	
	P124–P127	Input/output port 12	Input/output	
	P130–P137	Input/output port 13	Input/output	
	P150, P153	Input/output port 15	Input/output	
	P174, P175	Input/output port 17	Input/output	
	P220, P221 (Note 2), P224, P225	Input/output port 22	Input/output	

Note 1: Input/output ports 5, 14, 16 and 18–21 are nonexistent.

Note 2: P221 is input-only port.

1.4 Pin Assignments

Figure 1.4.1 and Figure 1.4.2 show the 32192/32195/32196's pin assignment diagram. A pin assignment table is shown in Table 1.4.1 and Table 1.4.2.

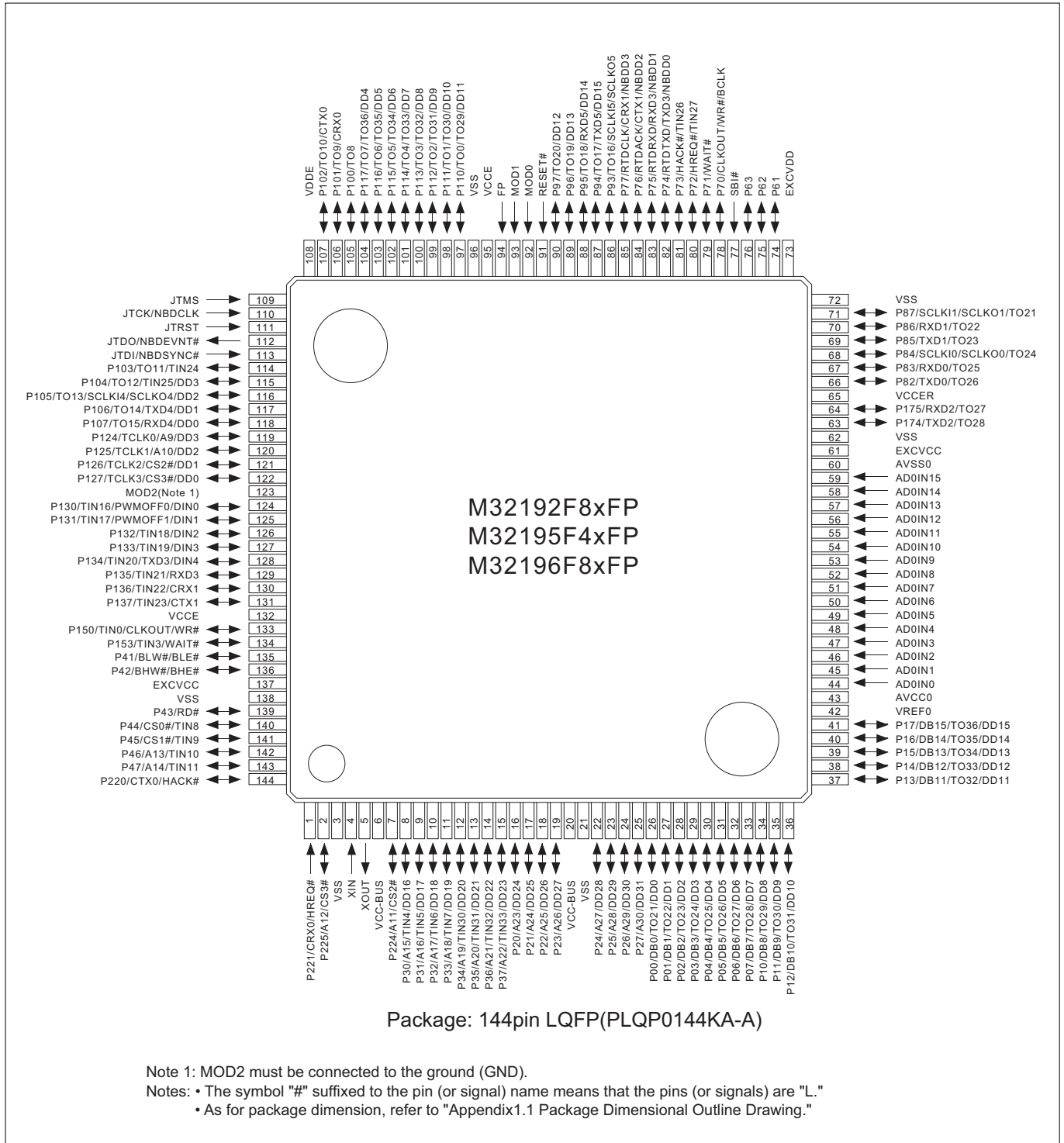


Figure 1.4.1 Pin Assignment Diagram of the M32192F8xFP, M32195F4xFP, and M32196F8xFP (Top View)

15	VSS	VDDE	P100/TO8	P115/TO5 /TO34/DD6	P112/TO2 /TO31/DD9	VSS	FP	N.C.	N.C.	P93/TO16 /SCLKI5 /SCLKO5	P75/RTDRXD /RXD3/NBDD1	P72/HREQ# /TIN27	SBI#	P61	EXCVDD
14	JTMS	P102/TO10 /CTX0	P101/TO9 /CRX0	P116/TO6 /TO35/DD5	P113/TO3 /TO32/DD8	N.C.	N.C.	RESET#	P95/TO18 /RXD5/DD14	P77/RTDCLK /CRX1/NBDD3	P74/RTDXTD /TXD3/NBDD0	P71/WAIT	P63	P62	VSS
13	JTDO /NBDEVNT#	JTRST	JTCK /NBDCLK	P117/TO7 /TO36/DD4	P114/TO4 /TO33/DD7	P110/TO0 /TO29/DD11	N.C.	MOD0	P94/TO17 /TXD5/DD15	P76/RTDACK /CTX1/NBDD2	P73/HACK# /TIN26	P70/CLKOUT /WR#/BCLK	P87/SCLKI1 /SCLKO1 /TO21	N.C.	P86/RXD1 /TO22
12	P103/TO11 /TIN24	JTDI /NBDSYNC#	VSS	P104/TO12 /TIN25/DD3	P111/TO1 /TO30/DD10	VCCE	MOD1	P97/TO20 /DD12	P96/TO19 /DD13	VSS	N.C.	VCCE	P85/TXD1 /TO23	P84/SCLK0 /SCLKO0 /TO24	P83/RXD0 /TO25
11	P107/TO15 /RXD4/DD0	P106/TO14 /TXD4/DD1	P105/TO13 /SCLKI4 /SCLKO4 /DD2	P124/TCLK0 /A9/DD3	THERMAL- BALL (Note 2)	THERMAL- BALL (Note 2)	THERMAL- BALL (Note 2)	THERMAL- BALL (Note 2)	THERMAL- BALL (Note 2)	THERMAL- BALL (Note 2)	THERMAL- BALL (Note 2)	P174/TXD2 /TO28	P82/TXD0 /TO26	VCCER	P175/RXD2 /TO27
10	P126/TCLK2 /CS2/DD1	N.C.	P125/TCLK1 /A10/DD2	N.C.	THERMAL- BALL (Note 2)	THERMAL- BALL (Note 2)	THERMAL- BALL (Note 2)	THERMAL- BALL (Note 2)	THERMAL- BALL (Note 2)	THERMAL- BALL (Note 2)	THERMAL- BALL (Note 2)	N.C.	N.C.	N.C.	N.C.
9	MOD2 (Note 1)	N.C.	P127/TCLK3 /CS3/DD0	N.C.	THERMAL- BALL (Note 2)	THERMAL- BALL (Note 2)	THERMAL- BALL (Note 2)	THERMAL- BALL (Note 2)	THERMAL- BALL (Note 2)	THERMAL- BALL (Note 2)	THERMAL- BALL (Note 2)	AD0IN15	VSS	EXCVCC	AVSS0
8	P131/TIN17 /PWMOFF1 /DIN1	P132/TIN18 /DIN2	P133/TIN19 /DIN3	P130/TIN16 /PWMOFF0 /DIN0	THERMAL- BALL (Note 2)	THERMAL- BALL (Note 2)	THERMAL- BALL (Note 2)	THERMAL- BALL (Note 2)	THERMAL- BALL (Note 2)	THERMAL- BALL (Note 2)	THERMAL- BALL (Note 2)	AD0IN14	AD0IN11	AD0IN12	AD0IN13
7	P135/TIN21 /RXD3	P136/TIN22 /CRX1	P137/TIN23 /CTX1	P134/TIN20 /TXD3/DIN4	THERMAL- BALL (Note 2)	THERMAL- BALL (Note 2)	THERMAL- BALL (Note 2)	THERMAL- BALL (Note 2)	THERMAL- BALL (Note 2)	THERMAL- BALL (Note 2)	THERMAL- BALL (Note 2)	AD0IN10	AD0IN7	AD0IN8	AD0IN9
6	P150/TIN0 /CLKOUT /WR#	P153/TIN3 /WAIT#	P41/BLW# /BLE#	VCCE	THERMAL- BALL (Note 2)	THERMAL- BALL (Note 2)	THERMAL- BALL (Note 2)	THERMAL- BALL (Note 2)	THERMAL- BALL (Note 2)	THERMAL- BALL (Note 2)	THERMAL- BALL (Note 2)	AD0IN6	AD0IN3	AD0IN4	AD0IN5
5	EXCVCC	VSS	P43/RD#	P42/BHW# /BHE#	THERMAL- BALL (Note 2)	THERMAL- BALL (Note 2)	THERMAL- BALL (Note 2)	THERMAL- BALL (Note 2)	THERMAL- BALL (Note 2)	THERMAL- BALL (Note 2)	THERMAL- BALL (Note 2)	AD0IN2	AVCC0	AD0IN0	AD0IN1
4	P45/CS1# TIN9	P46/A13 /TIN10	P47/A14 /TIN11	P44/CS0# /TIN8	P31/A16 /TIN5/DD17	P35/A20 /TIN31/DD21	P20/A23 /DD24	VCC-BUS	VSS	P26/A29 /DD30	P02/DB2 /TO23/DD2	VREF0	N.C.	P17/DB15 /TO36/DD15	VSS
3	P220/CTX0 /HACK#	P221/CRX0 /HREQ#	P225/A12 /CS3#	VCC-BUS	VCCER	P32/A17 /TIN6/DD18	N.C.	P21/A24 /DD25	P25/A28 /DD29	P01/DB1 /TO22/DD1	P05/DB5 /TO26/DD5	P10/DB8 /TO29/DD8	P15/DB13 /TO34/DD13	P16/DB14 /TO35/DD14	N.C.
2	VSS	N.C.	N.C.	VSS	P30/A15 /TIN4/DD16	P33/A18 /TIN7/DD19	P36/A21 /TIN32/DD22	P22/A25 /DD26	P24/A27 /DD28	P00/DB0 /TO21/DD0	P04/DB4 /TO25/DD4	P07/DB7 /TO28/DD7	P12/DB10 /TO31/DD10	P13/DB11 /TO32/DD11	P14/DB12 /TO33/DD12
1		XIN	XOUT	P224/A11 /CS2#	N.C.	P34/A19 /TIN30/DD20	P37/A22 /TIN33/DD23	P23/A26 /DD27	VSS	P27/A30 /DD31	P03/DB3 /TO24/DD3	P06/DB6 /TO27/DD6	P11/DB9 /TO30/DD9	N.C.	N.C.
	A	B	C	D	E	F	G	H	J	K	L	M	N	P	R

Package: 224pin FBGA

Note 1: MOD2 must be connected to the ground (GND).  
 Note 2: THERMAL BALL must be connected to the ground (GND).  
 Note: • The symbol "#" suffixed to the pin (or signal) name means that the pins (or signals) are "L."

Figure 1.4.2 Pin Assignment Diagram of the M32192F8xWG (Top View)

The pins directed for input go to a high-impedance state (Hi-Z) when reset. The term “when reset” means that input on RESET# pin is held “L” (the device remains reset), and that the RESET# pin is released back “H” (the device comes out of reset).

**Table 1.4.1 Pin Assignments of the M32192F8xFP, M32195F4xFP, and M32196F8xFP (1/4)**

Pin No.	Symbol	Function				Type	Power supply	Condition	Pin state when reset			
		Port	Function 1	Function 2	DRI function NBD function				Function	Type	State during reset	State upon exiting reset
1	P221/CRX0/HREQ#	P221	CRX0(Note 1)	HREQ#(Note 1)	-	Input	VCC-BUS		P221	Input	Hi-Z	Hi-Z
2	P225/A12/CS3#	P225	A12	CS3#(Note 1)	-	Input/output		During single-chip and external extension modes	P225	Input	Hi-Z	Hi-Z
							During processor mode	A12	Output	Hi-Z	Undefined	
3	VSS	-	VSS	-	-	-	-	VSS	-	-	-	-
4	XIN	-	XIN	-	-	Input	VCC-BUS		XIN	Input	-	-
5	XOUT	-	XOUT	-	-	Output			XOUT	Output	XOUT	XOUT
6	VCC-BUS	-	VCC-BUS	-	-	-	-	VCC-BUS	-	-	-	-
7	P224/A11/CS2#	P224	A11	CS2#(Note 1)	-	Input/output	VCC-BUS	During single-chip and external extension modes	P224	Input	Hi-Z	Hi-Z
								During processor mode	A11	Output	Hi-Z	Undefined
8	P30/A15/TIN4/DD16	P30	A15	TIN4	DD16	Input/output	VCC-BUS	During single-chip and external extension modes	P30	Input	Hi-Z	Hi-Z
								During processor mode	A15	Output	Hi-Z	Undefined
9	P31/A16/TIN5/DD17	P31	A16	TIN5	DD17	Input/output	VCC-BUS	During single-chip and external extension modes	P31	Input	Hi-Z	Hi-Z
								During processor mode	A16	Output	Hi-Z	Undefined
10	P32/A17/TIN6/DD18	P32	A17	TIN6	DD18	Input/output	VCC-BUS	During single-chip and external extension modes	P32	Input	Hi-Z	Hi-Z
								During processor mode	A17	Output	Hi-Z	Undefined
11	P33/A18/TIN7/DD19	P33	A18	TIN7	DD19	Input/output	VCC-BUS	During single-chip and external extension modes	P33	Input	Hi-Z	Hi-Z
								During processor mode	A18	Output	Hi-Z	Undefined
12	P34/A19/TIN30/DD20	P34	A19	TIN30	DD20	Input/output	VCC-BUS	During single-chip and external extension modes	P34	Input	Hi-Z	Hi-Z
								During processor mode	A19	Output	Hi-Z	Undefined
13	P35/A20/TIN31/DD21	P35	A20	TIN31	DD21	Input/output	VCC-BUS	During single-chip and external extension modes	P35	Input	Hi-Z	Hi-Z
								During processor mode	A20	Output	Hi-Z	Undefined
14	P36/A21/TIN32/DD22	P36	A21	TIN32	DD22	Input/output	VCC-BUS	During single-chip and external extension modes	P36	Input	Hi-Z	Hi-Z
								During processor mode	A21	Output	Hi-Z	Undefined
15	P37/A22/TIN33/DD23	P37	A22	TIN33	DD23	Input/output	VCC-BUS	During single-chip and external extension modes	P37	Input	Hi-Z	Hi-Z
								During processor mode	A22	Output	Hi-Z	Undefined
16	P20/A23/DD24	P20	A23	-	DD24	Input/output	VCC-BUS	During single-chip and external extension modes	P20	Input	Hi-Z	Hi-Z
								During processor mode	A23	Output	Hi-Z	Undefined
17	P21/A24/DD25	P21	A24	-	DD25	Input/output	VCC-BUS	During single-chip and external extension modes	P21	Input	Hi-Z	Hi-Z
								During processor mode	A24	Output	Hi-Z	Undefined
18	P22/A25/DD26	P22	A25	-	DD26	Input/output	VCC-BUS	During single-chip and external extension modes	P22	Input	Hi-Z	Hi-Z
								During processor mode	A25	Output	Hi-Z	Undefined
19	P23/A26/DD27	P23	A26	-	DD27	Input/output	VCC-BUS	During single-chip and external extension modes	P23	Input	Hi-Z	Hi-Z
								During processor mode	A26	Output	Hi-Z	Undefined
20	VCC-BUS	-	VCC-BUS	-	-	-	-	VCC-BUS	-	-	-	-
21	VSS	-	VSS	-	-	-	-	VSS	-	-	-	-
22	P24/A27/DD28	P24	A27	-	DD28	Input/output	VCC-BUS	During single-chip and external extension modes	P24	Input	Hi-Z	Hi-Z
								During processor mode	A27	Output	Hi-Z	Undefined
23	P25/A28/DD29	P25	A28	-	DD29	Input/output	VCC-BUS	During single-chip and external extension modes	P25	Input	Hi-Z	Hi-Z
								During processor mode	A28	Output	Hi-Z	Undefined
24	P26/A29/DD30	P26	A29	-	DD30	Input/output	VCC-BUS	During single-chip and external extension modes	P26	Input	Hi-Z	Hi-Z
								During processor mode	A29	Output	Hi-Z	Undefined
25	P27/A30/DD31	P27	A30	-	DD31	Input/output	VCC-BUS	During single-chip and external extension modes	P27	Input	Hi-Z	Hi-Z
								During processor mode	A30	Output	Hi-Z	Undefined
26	P00/DB0/TO21/DD0	P00	DB0	TO21(Note 1)	DD0(Note 1)	Input/output	VCC-BUS	During single-chip and external extension modes	P00	Input	Hi-Z	Hi-Z
								During processor mode	DB0	Input/output	Hi-Z	Hi-Z

Note 1: The pins outputted at two places.

Table 1.4.1 Pin Assignments of the M32192F8xFP, M32195F4xFP, and M32196F8xFP (2/4)

Pin No.	Symbol	Function				Type	Power supply	Condition	Pin state when reset			
		Port	Function 1	Function 2	DRI function NBD function				Function	Type	State during reset	State upon exiting reset
27	P01/DB1/ TO22/DD1	P01	DB1	TO22(Note 1)	DD1(Note 1)	Input/ output	VCC-BUS	During single-chip and external extension modes	P01	Input	Hi-Z	Hi-Z
28	P02/DB2/ TO23/DD2							During processor mode	DB1	Input/output	Hi-Z	Hi-Z
29	P03/DB3/ TO24/DD3	P03	DB3	TO24(Note 1)	DD3(Note 1)	Input/ output	VCC-BUS	During single-chip and external extension modes	P03	Input	Hi-Z	Hi-Z
30	P04/DB4/ TO25/DD4							During processor mode	DB3	Input/output	Hi-Z	Hi-Z
31	P05/DB5/ TO26/DD5	P05	DB5	TO26(Note 1)	DD5(Note 1)	Input/ output	VCC-BUS	During single-chip and external extension modes	P05	Input	Hi-Z	Hi-Z
32	P06/DB6/ TO27/DD6							During processor mode	DB5	Input/output	Hi-Z	Hi-Z
33	P07/DB7/ TO28/DD7	P07	DB7	TO28(Note 1)	DD7(Note 1)	Input/ output	VCC-BUS	During single-chip and external extension modes	P07	Input	Hi-Z	Hi-Z
34	P10/DB8/ TO29/DD8							During processor mode	DB7	Input/output	Hi-Z	Hi-Z
35	P11/DB9/ TO30/DD9	P11	DB9	TO30(Note 1)	DD9(Note 1)	Input/ output	VCC-BUS	During single-chip and external extension modes	P11	Input	Hi-Z	Hi-Z
36	P12/DB10/ TO31/DD10							During processor mode	DB9	Input/output	Hi-Z	Hi-Z
37	P13/DB11/ TO32/DD11	P13	DB11	TO32(Note 1)	DD11(Note 1)	Input/ output	VCC-BUS	During single-chip and external extension modes	P13	Input	Hi-Z	Hi-Z
38	P14/DB12/ TO33/DD12							During processor mode	DB11	Input/output	Hi-Z	Hi-Z
39	P15/DB13/ TO34/DD13	P15	DB13	TO34(Note 1)	DD13(Note 1)	Input/ output	VCC-BUS	During single-chip and external extension modes	P15	Input	Hi-Z	Hi-Z
40	P16/DB14/ TO35/DD14							During processor mode	DB13	Input/output	Hi-Z	Hi-Z
41	P17/DB15/ TO36/DD15	P17	DB15	TO36(Note 1)	DD15(Note 1)	Input/ output	VCC-BUS	During single-chip and external extension modes	P17	Input	Hi-Z	Hi-Z
42	VREF0							-	VREF0	-	-	-
43	AVCC0	-	AVCC0	-	-	-	-	VREF0	-	-	-	-
44	AD0IN0	-	AD0IN0	-	-	Input	-	AVCC0	-	-	-	-
45	AD0IN1	-	AD0IN1	-	-	Input	-	AD0IN0	Input	Hi-Z	Hi-Z	Hi-Z
46	AD0IN2	-	AD0IN2	-	-	Input	-	AD0IN1	Input	Hi-Z	Hi-Z	Hi-Z
47	AD0IN3	-	AD0IN3	-	-	Input	-	AD0IN2	Input	Hi-Z	Hi-Z	Hi-Z
48	AD0IN4	-	AD0IN4	-	-	Input	-	AD0IN3	Input	Hi-Z	Hi-Z	Hi-Z
49	AD0IN5	-	AD0IN5	-	-	Input	-	AD0IN4	Input	Hi-Z	Hi-Z	Hi-Z
50	AD0IN6	-	AD0IN6	-	-	Input	-	AD0IN5	Input	Hi-Z	Hi-Z	Hi-Z
51	AD0IN7	-	AD0IN7	-	-	Input	-	AD0IN6	Input	Hi-Z	Hi-Z	Hi-Z
52	AD0IN8	-	AD0IN8	-	-	Input	-	AD0IN7	Input	Hi-Z	Hi-Z	Hi-Z
53	AD0IN9	-	AD0IN9	-	-	Input	-	AD0IN8	Input	Hi-Z	Hi-Z	Hi-Z
54	AD0IN10	-	AD0IN10	-	-	Input	-	AD0IN9	Input	Hi-Z	Hi-Z	Hi-Z
55	AD0IN11	-	AD0IN11	-	-	Input	-	AD0IN10	Input	Hi-Z	Hi-Z	Hi-Z
56	AD0IN12	-	AD0IN12	-	-	Input	-	AD0IN11	Input	Hi-Z	Hi-Z	Hi-Z
57	AD0IN13	-	AD0IN13	-	-	Input	-	AD0IN12	Input	Hi-Z	Hi-Z	Hi-Z
58	AD0IN14	-	AD0IN14	-	-	Input	-	AD0IN13	Input	Hi-Z	Hi-Z	Hi-Z
59	AD0IN15	-	AD0IN15	-	-	Input	-	AD0IN14	Input	Hi-Z	Hi-Z	Hi-Z

Note 1: The pins outputted at two places.

Table 1.4.1 Pin Assignments of the M32192F8xFP, M32195F4xFP, and M32196F8xFP (3/4)

Pin No.	Symbol	Function				Type	Power supply	Condition	Pin state when reset			
		Port	Function 1	Function 2	DRI function NBD function				Function	Type	State during reset	State upon exiting reset
60	AVSS0	-	AVSS0	-	-	-	-	-	AVSS0	-	-	-
61	EXCVCC	-	EXCVCC	-	-	-	-	-	EXCVCC	-	-	-
62	VSS	-	VSS	-	-	-	-	-	VSS	-	-	-
63	P174/TXD2/TO28	P174	TXD2	TO28(Note 1)	-	Input/output	VCCE	-	P174	Input	Hi-Z	Hi-Z
64	P175/RXD2/TO27	P175	RXD2	TO27(Note 1)	-	Input/output	VCCE	-	P175	Input	Hi-Z	Hi-Z
65	VCCER	-	VCCER	-	-	-	-	-	VCCER	-	-	-
66	P82/TXD0/TO26	P82	TXD0	TO26(Note 1)	-	Input/output	VCCE	-	P82	Input	Hi-Z	Hi-Z
67	P83/RXD0/TO25	P83	RXD0	TO25(Note 1)	-	Input/output		-	P83	Input	Hi-Z	Hi-Z
68	P84/SCLK0/ SCLKO0/TO24	P84	SCLK0/ SCLKO0	TO24(Note 1)	-	Input/ output		-	P84	Input	Hi-Z	Hi-Z
69	P85/TXD1/TO23	P85	TXD1	TO23(Note 1)	-	Input/output		-	P85	Input	Hi-Z	Hi-Z
70	P86/RXD1/TO22	P86	RXD1	TO22(Note 1)	-	Input/output		-	P86	Input	Hi-Z	Hi-Z
71	P87/SCLK1/ SCLKO1/TO21	P87	SCLK1/ SCLKO1	TO21(Note 1)	-	Input/ output		-	P87	Input	Hi-Z	Hi-Z
72	VSS	-	VSS	-	-	-	-	-	VSS	-	-	-
73	EXCVDD	-	EXCVDD	-	-	-	-	-	EXCVDD	-	-	-
74	P61	P61	-	-	-	Input/output	VCCE	-	P61	Input	Hi-Z	Hi-Z
75	P62	P62	-	-	-	Input/output		-	P62	Input	Hi-Z	Hi-Z
76	P63	P63	-	-	-	Input/output		-	P63	Input	Hi-Z	Hi-Z
77	SBI#	-	SBI#	-	-	Input		-	SBI#	Input	Hi-Z	Hi-Z
78	P70/CLKOUT/WR# /BCLK	P70	CLKOUT/ WR#	BCLK	-	Input/ output		-	P70	Input	Hi-Z	Hi-Z
79	P71/WAIT#	P71	WAIT#	-	-	Input/output		-	P71	Input	Hi-Z	Hi-Z
80	P72/HREQ#/TIN27	P72	HREQ#	TIN27	-	Input/output		-	P72	Input	Hi-Z	Hi-Z
81	P73/HACK#/TIN26	P73	HACK#	TIN26	-	Input/output		-	P73	Input	Hi-Z	Hi-Z
82	P74/RTDX/ TXD3/NBDD0	P74	RTDX	TXD3(Note 1)	NBDD0	Input/ output		-	P74	Input	Hi-Z	Hi-Z
83	P75/RTDRXD/ RXD3/NBDD1	P75	RTDRXD	RXD3(Note 1)	NBDD1	Input/ output		-	P75	Input	Hi-Z	Hi-Z
84	P76/RTDACK/ CTX1/NBDD2	P76	RTDACK	CTX1(Note 1)	NBDD2	Input/ output		-	P76	Input	Hi-Z	Hi-Z
85	P77/RTDCLK/ CRX1/NBDD3	P77	RTDCLK	CRX1(Note 1)	NBDD3	Input/ output		-	P77	Input	Hi-Z	Hi-Z
86	P93/TO16/ SCLK15/SCLKO5	P93	TO16	SCLK15/ SCLKO5	-	Input/ output		-	P93	Input	Hi-Z	Hi-Z
87	P94/TO17/ TXD5/DD15	P94	TO17	TXD5	DD15(Note 1)	Input/ output		-	P94	Input	Hi-Z	Hi-Z
88	P95/TO18/ RXD5/DD14	P95	TO18	RXD5	DD14(Note 1)	Input/ output	-	P95	Input	Hi-Z	Hi-Z	
89	P96/TO19/DD13	P96	TO19	-	DD13(Note 1)	Input/output	-	P96	Input	Hi-Z	Hi-Z	
90	P97/TO20/DD12	P97	TO20	-	DD12(Note 1)	Input/output	-	P97	Input	Hi-Z	Hi-Z	
91	RESET#	-	RESET#	-	-	Input	-	RESET#	Input	Hi-Z	Hi-Z	
92	MOD0	-	MOD0	-	-	Input	-	MOD0	Input	Hi-Z	Hi-Z	
93	MOD1	-	MOD1	-	-	Input	-	MOD1	Input	Hi-Z	Hi-Z	
94	FP	-	FP	-	-	Input	-	FP	Input	Hi-Z	Hi-Z	
95	VCCE	-	VCCE	-	-	-	-	-	VCCE	-	-	-
96	VSS	-	VSS	-	-	-	-	-	VSS	-	-	-
97	P110/TO0/TO29/DD11	P110	TO0	TO29(Note 1)	DD11(Note 1)	Input/output	VCCE	-	P110	Input	Hi-Z	Hi-Z
98	P111/TO1/TO30/DD10	P111	TO1	TO30(Note 1)	DD10(Note 1)	Input/output		-	P111	Input	Hi-Z	Hi-Z
99	P112/TO2/TO31/DD9	P112	TO2	TO31(Note 1)	DD9(Note 1)	Input/output		-	P112	Input	Hi-Z	Hi-Z
100	P113/TO3/TO32/DD8	P113	TO3	TO32(Note 1)	DD8(Note 1)	Input/output		-	P113	Input	Hi-Z	Hi-Z
101	P114/TO4/TO33/DD7	P114	TO4	TO33(Note 1)	DD7(Note 1)	Input/output		-	P114	Input	Hi-Z	Hi-Z
102	P115/TO5/TO34/DD6	P115	TO5	TO34(Note 1)	DD6(Note 1)	Input/output		-	P115	Input	Hi-Z	Hi-Z
103	P116/TO6/TO35/DD5	P116	TO6	TO35(Note 1)	DD5(Note 1)	Input/output		-	P116	Input	Hi-Z	Hi-Z
104	P117/TO7/TO36/DD4	P117	TO7	TO36(Note 1)	DD4(Note 1)	Input/output		-	P117	Input	Hi-Z	Hi-Z
105	P100/TO8	P100	TO8	-	-	Input/output		-	P100	Input	Hi-Z	Hi-Z
106	P101/TO9/CRX0	P101	TO9	CRX0(Note 1)	-	Input/output		-	P101	Input	Hi-Z	Hi-Z
107	P102/TO10/CTX0	P102	TO10	CTX0(Note 1)	-	Input/output	-	P102	Input	Hi-Z	Hi-Z	
108	VDDE	-	VDDE	-	-	-	-	-	VDDE	-	-	-
109	JTMS (Note 2)	-	JTMS	-	-	Input	VCCE	-	JTMS	Input	Hi-Z	Hi-Z
110	JTCK/NBDCLK (Note 2)	-	JTCK	-	NBDCLK	Input		-	JTCK	Input	Hi-Z	Hi-Z
111	JTRST (Note 2)	-	JTRST	-	-	Input		-	JTRST	Input	Hi-Z	Hi-Z
112	JTDO/NBDEVNT# (Note 2)	-	JTDO	-	NBDEVNT#	Output		-	JTDO	Output	Hi-Z	Hi-Z
113	JTDI/NBDSYNC# (Note 2)	-	JTDI	-	NBDSYNC#	Input		-	JTDI	Input	Hi-Z	Hi-Z
114	P103/TO11/TIN24	P103	TO11	TIN24	-	Input/output		-	P103	Input	Hi-Z	Hi-Z
115	P104/TO12/TIN25/DD3	P104	TO12	TIN25	DD3(Note 1)	Input/output		-	P104	Input	Hi-Z	Hi-Z
116	P105/TO13/ SCLK4/SCLKO4/DD2	P105	TO13	SCLK4/ SCLKO4	DD2(Note 1)	Input/ output		-	P105	Input	Hi-Z	Hi-Z
117	P106/TO14/TXD4/DD1	P106	TO14	TXD4	DD1(Note 1)	Input/output		-	P106	Input	Hi-Z	Hi-Z

Note 1: The pins outputted at two places.

Note 2: The JTCK, JTDI, JTDO and JTMS pins are reset by input from the JTRST pin, and not reset from the RESET# pin.



**Table 1.4.1 Pin Assignments of the M32192F8xFP, M32195F4xFP, and M32196F8xFP (4/4)**

Pin No.	Symbol	Function				Type	Power supply	Condition	Pin state when reset			
		Port	Function 1	Function 2	DRI function NBD function				Function	Type	State during reset	State upon exiting reset
118	P107/TO15/RXD4/DD0	P107	TO15	RXD4	DD0(*)	Input/output	VCCCE		P107	Input	Hi-Z	Hi-Z
119	P124/TCLK0/A9/DD3	P124	TCLK0	A9	DD3(*)	Input/output		During single-chip and external extension modes	P124	Input	Hi-Z	Hi-Z
								During processor mode	A9	Output	Hi-Z	Hi-Z
120	P125/TCLK1/A10/DD2	P125	TCLK1	A10	DD2(*)	Input/output		During single-chip and external extension modes	P125	Input	Hi-Z	Hi-Z
								During processor mode	A10	Output	Hi-Z	Hi-Z
121	P126/TCLK2/CS2#/DD1	P126	TCLK2	CS2#(*)	DD1(*)	Input/output			P126	Input	Hi-Z	Hi-Z
122	P127/TCLK3/CS3#/DD0	P127	TCLK3	CS3#(*)	DD0(*)	Input/output			P127	Input	Hi-Z	Hi-Z
123	MOD2	-	MOD2	-	-	-			MOD2	-	-	-
124	P130/TIN16/PWMOFF0/DIN0	P130	TIN16/ PWMOFF0	-	DIN0	Input/output			P130	Input	Hi-Z	Hi-Z
125	P131/TIN17/PWMOFF1/DIN1	P131	TIN17/ PWMOFF1	-	DIN1	Input/output			P131	Input	Hi-Z	Hi-Z
126	P132/TIN18/DIN2	P132	TIN18	-	DIN2	Input/output			P132	Input	Hi-Z	Hi-Z
127	P133/TIN19/DIN3	P133	TIN19	-	DIN3	Input/output			P133	Input	Hi-Z	Hi-Z
128	P134/TIN20/TXD3/DIN4	P134	TIN20	TXD3(*)	DIN4	Input/output			P134	Input	Hi-Z	Hi-Z
129	P135/TIN21/RXD3	P135	TIN21	RXD3(*)	-	Input/output			P135	Input	Hi-Z	Hi-Z
130	P136/TIN22/CRX1	P136	TIN22	CRX1(*)	-	Input/output		P136	Input	Hi-Z	Hi-Z	
131	P137/TIN23/CTX1	P137	TIN23	CTX1(*)	-	Input/output		P137	Input	Hi-Z	Hi-Z	
132	VCCE	-	VCCE	-	-	-	-	VCCE	-	-	-	
133	P150/TIN0/CLKOUT/WR#	P150	TIN0	CLKOUT(*)/ WR#(*)	-	Input/output	VCC-BUS		P150	Input	Hi-Z	Hi-Z
134	P153/TIN3/WAIT#	P153	TIN3	WAIT#(*)	-	Input/output			P153	Input	Hi-Z	Hi-Z
								During single-chip mode	P41	Input	Hi-Z	Hi-Z
135	P41/BLW#/BLE#	P41	BLW#/ BLE#	-	-	Input/output		During external extension and processor modes	BLW#/ BLE#	Output	Hi-Z	"H" level
136	P42/BHW#/BHE#	P42	BHW#/ BHE#	-	-	Input/output	During single-chip mode	P42	Input	Hi-Z	Hi-Z	
							During external extension and processor modes	BHW#/ BHE#	Output	Hi-Z	"H" level	
137	EXCVCC	-	EXCVCC	-	-	-	-	EXCVCC	-	-	-	
138	VSS	-	VSS	-	-	-	-	VSS	-	-	-	
139	P43/RD#	P43	RD#	-	-	Input/output	VCC-BUS	During single-chip mode	P43	Input	Hi-Z	Hi-Z
								During external extension and processor modes	RD#	Output	Hi-Z	"H" level
140	P44/CS0#/TIN8	P44	CS0#	TIN8	-	Input/output		During single-chip and external extension modes	P44	Input	Hi-Z	Hi-Z
								During processor mode	CS0#	Output	Hi-Z	"H" level
141	P45/CS1#/TIN9	P45	CS1#	TIN9	-	Input/output		During single-chip and external extension modes	P45	Input	Hi-Z	Hi-Z
								During processor mode	CS1#	Output	Hi-Z	"H" level
142	P46/A13/TIN10	P46	A13	TIN10	-	Input/output		During single-chip and external extension modes	P46	Input	Hi-Z	Hi-Z
								During processor mode	A13	Output	Hi-Z	Undefined
143	P47/A14/TIN11	P47	A14	TIN11	-	Input/output	During single-chip and external extension modes	P47	Input	Hi-Z	Hi-Z	
							During processor mode	A14	Output	Hi-Z	Undefined	
144	P220/CTX0/HACK#	P220	CTX0(*)	HACK#(*)	-	Input/output		P220	Input	Hi-Z	Hi-Z	

Note 1: The pins outputted at two places.



Table 1.4.2 Pin Assignments of the M32192F8xWG (1/4)

Pin No.	Symbol	Function				Type	Power supply	Condition	Pin state when reset				
		Port	Function 1	Function 2	DRI function NBD function				Function	Type	State during reset	State upon exiting reset	
A1	-----	-	-	-	-	-	-	-	-	-	-	-	-
A2	VSS	-	VSS	-	-	-	-	-	VSS	-	-	-	-
A3	P220/CTX0/HACK#	P220	CTX0 (Note 1)	HACK# (Note 1)	-	Input/Output	VCC-BUS	-	P220	Input	Hi-Z	Hi-Z	-
A4	P45/CS1#/TIN9	P45	CS1#	TIN9	-	Input/Output	VCC-BUS	During single-chip and external extension modes	P45	Input	Hi-Z	Hi-Z	-
A5	EXCVCC	-	EXCVCC	-	-	-	-	During processor mode	CS1#	Output	Hi-Z	"H" level	-
A6	P150/TIN0/CLKOUT/WR#	P150	TIN0	CLKOUT (Note 1)	-	Input/Output	VCC-BUS	-	EXCVCC	-	-	-	-
A7	P135/TIN21/RXD3	P135	TIN21	RXD3 (Note 1)	-	Input/Output	VCCE	-	P150	Input	Hi-Z	Hi-Z	-
A8	P131/TIN17/PWMOFF1/DIN1	P131	TIN17/PWMOFF1	-	DIN1	Input/Output	VCCE	-	P135	Input	Hi-Z	Hi-Z	-
A9	MOD2	-	MOD2	-	-	-	VCCE	-	P131	Input	Hi-Z	Hi-Z	-
A10	P126/TCLK2/CS2#/DD1	P126	TCLK2	CS2# (Note 1)	DD1 (Note 1)	Input/Output	VCCE	-	MOD2	-	-	-	-
A11	P107/TO15/RXD4/DD0	P107	TO15	RXD4	DD0 (Note 1)	Input/Output	VCCE	-	P126	Input	Hi-Z	Hi-Z	-
A12	P103/TO11/TIN24	P103	TO11	TIN24	-	Input/Output	VCCE	-	P107	Input	Hi-Z	Hi-Z	-
A13	JTDO/NBDEVNT# (Note 2)	-	JTDO	-	NBDEVNT#	Output	VCCE	-	P103	Input	Hi-Z	Hi-Z	-
A14	JTMS (Note 2)	-	JTMS	-	-	Input	VCCE	-	JTDO	Output	Hi-Z	Hi-Z	-
A15	VSS	-	VSS	-	-	-	-	-	JTMS	Input	Hi-Z	Hi-Z	-
B1	XIN	-	XIN	-	-	Input	VCC-BUS	-	VSS	-	-	-	-
B2	N.C.	-	-	-	-	-	-	-	XIN	Input	-	-	-
B3	P221/CRX0/HREQ#	P221	CRX0 (Note 1)	HREQ# (Note 1)	-	Input	VCC-BUS	-	-	-	-	-	-
B4	P46/A13/TIN10	P46	A13	TIN10	-	Input/Output	VCC-BUS	During single-chip and external extension modes	P221	Input	Hi-Z	Hi-Z	-
B5	VSS	-	VSS	-	-	-	-	During processor mode	A13	Output	Hi-Z	Undefined	-
B6	P153/TIN3/WAIT#	P153	TIN3	WAIT# (Note 1)	-	Input/Output	VCC-BUS	-	VSS	-	-	-	-
B7	P136/TIN22/CRX1	P136	TIN22	CRX1 (Note 1)	-	Input/Output	VCCE	-	P153	Input	Hi-Z	Hi-Z	-
B8	P132/TIN18/DIN2	P132	TIN18	-	DIN2	Input/Output	VCCE	-	P136	Input	Hi-Z	Hi-Z	-
B9	N.C.	-	-	-	-	-	-	-	P132	Input	Hi-Z	Hi-Z	-
B10	N.C.	-	-	-	-	-	-	-	-	-	-	-	-
B11	P106/TO14/TXD4/DD1	P106	TO14	TXD4	DD1 (Note 1)	Input/Output	VCCE	-	-	-	-	-	-
B12	JTDI/NBDSYNC# (Note 2)	-	JTDI	-	NBDSYNC#	Input	VCCE	-	P106	Input	Hi-Z	Hi-Z	-
B13	JTRST (Note 2)	-	JTRST	-	-	Input	VCCE	-	JTDI	Input	Hi-Z	Hi-Z	-
B14	P102/TO10/CTX0	P102	TO10	CTX0 (Note 1)	-	Input/Output	VCCE	-	JTRST	Input	Hi-Z	Hi-Z	-
B15	VDDE	-	VDDE	-	-	-	-	-	P102	Input	Hi-Z	Hi-Z	-
C1	XOUT	-	XOUT	-	-	Input	VCC-BUS	-	VDDE	-	-	-	-
C2	N.C.	-	-	-	-	-	-	-	XOUT	Output	XOUT	XOUT	-
C3	P225/A12/CS3#	P225	A12	CS3# (Note 1)	-	Input/Output	VCC-BUS	During single-chip and external extension modes	P225	Input	Hi-Z	Hi-Z	-
C4	P47/A14/TIN11	P47	A14	TIN11	-	Input/Output	VCC-BUS	During processor mode	A12	Output	Hi-Z	Undefined	-
C5	P43/RD#	P43	RD#	-	-	Input/Output	VCC-BUS	During single-chip and external extension modes	P47	Input	Hi-Z	Hi-Z	-
C6	P41/BLW#/BLE#	P41	BLW#/BLE#	-	-	Input/Output	VCC-BUS	During processor mode	A14	Output	Hi-Z	Undefined	-
C7	P137/TIN23/CTX1	P137	TIN23	CTX1 (Note 1)	-	Input/Output	VCCE	During single-chip and external extension modes	P43	Input	Hi-Z	Hi-Z	-
C8	P133/TIN19/DIN3	P133	TIN19	-	DIN3	Input/Output	VCCE	During processor mode	RD#	Output	Hi-Z	"H" level	-
C9	P127/TCLK3/CS3#/DD0	P127	TCLK3	CS3# (Note 1)	DD0 (Note 1)	Input/Output	VCCE	-	P41	Input	Hi-Z	Hi-Z	-
C10	P125/TCLK1/A10/DD2	P125	TCLK1	A10	DD2 (Note 1)	Input/Output	VCCE	During single-chip and external extension modes	BLW#/BLE#	Output	Hi-Z	"H" level	-
C11	P105/TO13/SCLKI4/SCLKO4/DD2	P105	TO13	SCLKI4/SCLKO4	DD2 (Note 1)	Input/Output	VCCE	During processor mode	P137	Input	Hi-Z	Hi-Z	-
C12	VSS	-	VSS	-	-	-	-	-	P133	Input	Hi-Z	Hi-Z	-
C13	JTCK/NBDCLK (Note 2)	-	JTCK	-	NBDCLK	Input	VCCE	-	P127	Input	Hi-Z	Hi-Z	-
C14	P101/TO9/CRX0	P101	TO9	CRX0 (Note 1)	-	Input/Output	VCCE	-	P125	Input	Hi-Z	Hi-Z	-
C15	P100/TO8	P100	TO8	-	-	Input/Output	VCCE	-	P105	Input	Hi-Z	Hi-Z	-
D1	P224/A11/CS2#	P224	A11	CS2# (Note 1)	-	Input/Output	VCC-BUS	During single-chip and external extension modes	P100	Input	Hi-Z	Hi-Z	-
D2	VSS	-	VSS	-	-	Input/Output	-	During processor mode	A11	Output	Hi-Z	Undefined	-
D3	VCC-BUS	-	VCC-BUS	-	-	-	-	-	VSS	-	-	-	-
D4	P44/CS0#/TIN8	P44	CS0#	TIN8	-	Input/Output	VCC-BUS	During single-chip and external extension modes	VCC-BUS	-	-	-	-
D5	P42/BHW#/BHE#	P42	BHW#/BHE#	-	-	Input/Output	VCC-BUS	During processor mode	P44	Input	Hi-Z	Hi-Z	-
D6	VCCE	-	VCCE	-	-	Input/Output	-	During single-chip mode	CS0#	Output	Hi-Z	"H" level	-
D7	P134/TIN20/TXD3/DIN4	P134	TIN20	TXD3 (Note 1)	DIN4	Input/Output	VCCE	During single-chip and external extension modes	P42	Input	Hi-Z	Hi-Z	-
D8	P130/TIN16/PWMOFF0/DIN0	P130	TIN16/PWMOFF0	-	DIN0	Input/Output	VCCE	-	BHW#/BHE#	Output	Hi-Z	"H" level	-
D9	N.C.	-	-	-	-	-	-	-	VCCE	-	-	-	-
D10	N.C.	-	-	-	-	-	-	-	-	-	-	-	-
D11	P124/TCLK0/A9/DD3	P124	TCLK0	A9	DD3 (Note 1)	Input/Output	VCCE	During single-chip and external extension modes	P134	Input	Hi-Z	Hi-Z	-
D12	P104/TO12/TIN25/DD3	P104	TO12	TIN25	DD3 (Note 1)	Input/Output	VCCE	During processor mode	P130	Input	Hi-Z	Hi-Z	-
D13	P117/TO7/TO36/DD4	P117	TO7	TO36 (Note 1)	DD4 (Note 1)	Input/Output	VCCE	-	A9	Output	Hi-Z	Hi-Z	-
D14	P116/TO6/TO35/DD5	P116	TO6	TO35 (Note 1)	DD5 (Note 1)	Input/Output	VCCE	-	P104	Input	Hi-Z	Hi-Z	-
D15	P115/TO5/TO34/DD6	P115	TO5	TO34 (Note 1)	DD6 (Note 1)	Input/Output	VCCE	-	P117	Input	Hi-Z	Hi-Z	-
E1	N.C.	-	-	-	-	-	-	-	P116	Input	Hi-Z	Hi-Z	-
E2	P30/A15/TIN4/DD16	P30	A15	TIN4	DD16	Input/Output	VCC-BUS	During single-chip and external extension modes	P115	Input	Hi-Z	Hi-Z	-
E3	VCCER	-	VCCER	-	-	Input/Output	-	During processor mode	P30	Input	Hi-Z	Hi-Z	-
E4	P31/A16/TIN5/DD17	P31	A16	TIN5	DD17	Input/Output	VCC-BUS	During single-chip and external extension modes	A15	Output	Hi-Z	Undefined	-
E5	THERMAL-BALL (Note 3)	-	VSS	-	-	Input/Output	-	During processor mode	VCCER	-	-	-	-

Note 1: The pins outputted at two places.

Note 2: The JTCK, JTDI, JTDO and JTMS pins are reset by input from the JTRST pin, and not reset from the RESET# pin.

Note 3: THERMAL BALL must be connected to the ground (GND).

Table 1.4.2 Pin Assignments of the M32192F8xWG (2/4)

Pin No.	Symbol	Function				Type	Power supply	Condition	Pin state when reset			
		Port	Function 1	Function 2	DRI function NBD function				Function	Type	State during reset	State upon exiting reset
E6	THERMAL-BALL (Note 3)	-	VSS	-	-	-	-	-	VSS	-	-	-
E7	THERMAL-BALL (Note 3)	-	VSS	-	-	-	-	-	VSS	-	-	-
E8	THERMAL-BALL (Note 3)	-	VSS	-	-	-	-	-	VSS	-	-	-
E9	THERMAL-BALL (Note 3)	-	VSS	-	-	-	-	-	VSS	-	-	-
E10	THERMAL-BALL (Note 3)	-	VSS	-	-	-	-	-	VSS	-	-	-
E11	THERMAL-BALL (Note 3)	-	VSS	-	-	-	-	-	VSS	-	-	-
E12	P111/TO1/TO30/DD10	P111	TO1	TO30 (Note 1)	DD10 (Note 1)	Input/Output	VCCE		P111	Input	Hi-Z	Hi-Z
E13	P114/TO4/TO33/DD7	P114	TO4	TO33 (Note 1)	DD7 (Note 1)	Input/Output	VCCE		P114	Input	Hi-Z	Hi-Z
E14	P113/TO3/TO32/DD8	P113	TO3	TO32 (Note 1)	DD8 (Note 1)	Input/Output	VCCE		P113	Input	Hi-Z	Hi-Z
E15	P112/TO2/TO31/DD9	P112	TO2	TO31 (Note 1)	DD9 (Note 1)	Input/Output	VCCE		P112	Input	Hi-Z	Hi-Z
F1	P34/A19/TIN30/DD20	P34	A19	TIN30	DD20	Input/Output	VCC-BUS	During single-chip and external extension modes	P34	Input	Hi-Z	Hi-Z
								During processor mode	A19	Output	Hi-Z	Undefined
F2	P33/A18/TIN7/DD19	P33	A18	TIN7	DD19	Input/Output	VCC-BUS	During single-chip and external extension modes	P33	Input	Hi-Z	Hi-Z
								During processor mode	A18	Output	Hi-Z	Undefined
F3	P32/A17/TIN6/DD18	P32	A17	TIN6	DD18	Input/Output	VCC-BUS	During single-chip and external extension modes	P32	Input	Hi-Z	Hi-Z
								During processor mode	A17	Output	Hi-Z	Undefined
F4	P35/A20/TIN31/DD21	P35	A20	TIN31	DD21	Input/Output	VCC-BUS	During single-chip and external extension modes	P35	Input	Hi-Z	Hi-Z
								During processor mode	A20	Output	Hi-Z	Undefined
F5	THERMAL-BALL (Note 3)	-	VSS	-	-	-	-	-	VSS	-	-	-
F6	THERMAL-BALL (Note 3)	-	VSS	-	-	-	-	-	VSS	-	-	-
F7	THERMAL-BALL (Note 3)	-	VSS	-	-	-	-	-	VSS	-	-	-
F8	THERMAL-BALL (Note 3)	-	VSS	-	-	-	-	-	VSS	-	-	-
F9	THERMAL-BALL (Note 3)	-	VSS	-	-	-	-	-	VSS	-	-	-
F10	THERMAL-BALL (Note 3)	-	VSS	-	-	-	-	-	VSS	-	-	-
F11	THERMAL-BALL (Note 3)	-	VSS	-	-	-	-	-	VSS	-	-	-
F12	VCCE	-	VCCE	-	-	-	-	-	VCCE	-	-	-
F13	P110/TO0/TO29/DD11	P110	TO0	TO29 (Note 1)	DD11 (Note 1)	Input/Output	VCCE		P110	Input	Hi-Z	Hi-Z
F14	N.C.	-	-	-	-	-	-	-	-	-	-	-
F15	VSS	-	VSS	-	-	-	-	-	VSS	-	-	-
G1	P37/A22/TIN33/DD23	P37	A22	TIN33	DD23	Input/Output	VCC-BUS	During single-chip and external extension modes	P37	Input	Hi-Z	Hi-Z
								During processor mode	A22	Output	Hi-Z	Undefined
G2	P36/A21/TIN32/DD22	P36	A21	TIN32	DD22	Input/Output	VCC-BUS	During single-chip and external extension modes	P36	Input	Hi-Z	Hi-Z
								During processor mode	A21	Output	Hi-Z	Undefined
G3	N.C.	-	-	-	-	-	-	-	-	-	-	-
G4	P20/A23/DD24	P20	A23	-	DD24	Input/Output	VCC-BUS	During single-chip and external extension modes	P20	Input	Hi-Z	Hi-Z
								During processor mode	A23	Output	Hi-Z	Undefined
G5	THERMAL-BALL (Note 3)	-	VSS	-	-	-	-	-	VSS	-	-	-
G6	THERMAL-BALL (Note 3)	-	VSS	-	-	-	-	-	VSS	-	-	-
G7	THERMAL-BALL (Note 3)	-	VSS	-	-	-	-	-	VSS	-	-	-
G8	THERMAL-BALL (Note 3)	-	VSS	-	-	-	-	-	VSS	-	-	-
G9	THERMAL-BALL (Note 3)	-	VSS	-	-	-	-	-	VSS	-	-	-
G10	THERMAL-BALL (Note 3)	-	VSS	-	-	-	-	-	VSS	-	-	-
G11	THERMAL-BALL (Note 3)	-	VSS	-	-	-	-	-	VSS	-	-	-
G12	MOD1	-	MOD1	-	-	Input	VCCE		MOD1	Input	Hi-Z	Hi-Z
G13	N.C.	-	-	-	-	-	-	-	-	-	-	-
G14	N.C.	-	-	-	-	-	-	-	-	-	-	-
G15	FP	-	FP	-	-	Input	VCCE		FP	Input	Hi-Z	Hi-Z
H1	P23/A26/DD27	P23	A26	-	DD27	Input/Output	VCC-BUS	During single-chip and external extension modes	P23	Input	Hi-Z	Hi-Z
								During processor mode	A26	Output	Hi-Z	Undefined
H2	P22/A25/DD26	P22	A25	-	DD26	Input/Output	VCC-BUS	During single-chip and external extension modes	P22	Input	Hi-Z	Hi-Z
								During processor mode	A25	Output	Hi-Z	Undefined
H3	P21/A24/DD25	P21	A24	-	DD25	Input/Output	VCC-BUS	During single-chip and external extension modes	P21	Input	Hi-Z	Hi-Z
								During processor mode	A24	Output	Hi-Z	Undefined
H4	VCC-BUS	-	VCC-BUS	-	-	-	-	-	VCC-BUS	-	-	-
H5	THERMAL-BALL (Note 3)	-	VSS	-	-	-	-	-	VSS	-	-	-
H6	THERMAL-BALL (Note 3)	-	VSS	-	-	-	-	-	VSS	-	-	-
H7	THERMAL-BALL (Note 3)	-	VSS	-	-	-	-	-	VSS	-	-	-
H8	THERMAL-BALL (Note 3)	-	VSS	-	-	-	-	-	VSS	-	-	-
H9	THERMAL-BALL (Note 3)	-	VSS	-	-	-	-	-	VSS	-	-	-
H10	THERMAL-BALL (Note 3)	-	VSS	-	-	-	-	-	VSS	-	-	-
H11	THERMAL-BALL (Note 3)	-	VSS	-	-	-	-	-	VSS	-	-	-
H12	P97/TO20/DD12	P97	TO20	-	DD12 (Note 1)	Input/Output	VCCE		P97	Input	Hi-Z	Hi-Z
H13	MOD0	-	MOD0	-	-	Input	VCCE		MOD0	Input	Hi-Z	Hi-Z
H14	RESET#	-	RESET#	-	-	Input	VCCE		RESET#	Input	Hi-Z	Hi-Z
H15	N.C.	-	-	-	-	-	-	-	-	-	-	-
J1	VSS	-	VSS	-	-	-	-	-	VSS	-	-	-
J2	P24/A27/DD28	P24	A27	-	DD28	Input/Output	VCC-BUS	During single-chip and external extension modes	P24	Input	Hi-Z	Hi-Z
								During processor mode	A27	Output	Hi-Z	Undefined
J3	P25/A28/DD29	P25	A28	-	DD29	Input/Output	VCC-BUS	During single-chip and external extension modes	P25	Input	Hi-Z	Hi-Z
								During processor mode	A28	Output	Hi-Z	Undefined
J4	VSS	-	VSS	-	-	-	-	-	VSS	-	-	-
J5	THERMAL-BALL (Note 3)	-	VSS	-	-	-	-	-	VSS	-	-	-
J6	THERMAL-BALL (Note 3)	-	VSS	-	-	-	-	-	VSS	-	-	-
J7	THERMAL-BALL (Note 3)	-	VSS	-	-	-	-	-	VSS	-	-	-
J8	THERMAL-BALL (Note 3)	-	VSS	-	-	-	-	-	VSS	-	-	-
J9	THERMAL-BALL (Note 3)	-	VSS	-	-	-	-	-	VSS	-	-	-
J10	THERMAL-BALL (Note 3)	-	VSS	-	-	-	-	-	VSS	-	-	-
J11	THERMAL-BALL (Note 3)	-	VSS	-	-	-	-	-	VSS	-	-	-
J12	P96/TO19/DD13	P96	TO19	-	DD13 (Note 1)	Input/Output	VCCE		P96	Input	Hi-Z	Hi-Z
J13	P94/TO17/TXD5/DD15	P94	TO17	TXD5	DD15 (Note 1)	Input/Output	VCCE		P94	Input	Hi-Z	Hi-Z
J14	P95/TO18/RXD5/DD14	P95	TO18	RXD5	DD14 (Note 1)	Input/Output	VCCE		P95	Input	Hi-Z	Hi-Z
J15	N.C.	-	-	-	-	-	-	-	-	-	-	-
K1	P27/A30/DD31	P27	A30	-	DD31	Input/Output	VCC-BUS	During single-chip and external extension modes	P27	Input	Hi-Z	Hi-Z
								During processor mode	A30	Output	Hi-Z	Undefined
K2	P00/DB0/TO21/DD0	P00	DB0	TO21 (Note 1)	DD0 (Note 1)	Input/Output	VCC-BUS	During single-chip and external extension modes	P00	Input	Hi-Z	Hi-Z
								During processor mode	DB0	Input/Output	Hi-Z	Hi-Z

Note 1: The pins outputted at two places.

Note 2: The JTCK, JTDI, JTDO and JTMS pins are reset by input from the JTRST pin, and not reset from the RESET# pin.

Note 3: THERMAL BALL must be connected to the ground (GND).

Table 1.4.2 Pin Assignments of the M32192F8xWG (3/4)

Pin No.	Symbol	Function				Type	Power supply	Condition	Pin state when reset			
		Port	Function 1	Function 2	DRI function NBD function				Function	Type	State during reset	State upon exiting reset
K3	P01/DB1/TO22/DD1	P01	DB1	TO22 (Note 1)	DD1 (Note 1)	Input/Output	VCC-BUS	During single-chip and external extension modes	P01	Input	Hi-Z	Hi-Z
								During processor mode	DB1	Input/Output	Hi-Z	Hi-Z
K4	P26/A29/DD30	P26	A29	-	DD30	Input/Output	VCC-BUS	During single-chip and external extension modes	P26	Input	Hi-Z	Hi-Z
								During processor mode	A29	Output	Hi-Z	Undefined
K5	THERMAL-BALL (Note 3)	-	VSS	-	-	-	-	-	VSS	-	-	-
K6	THERMAL-BALL (Note 3)	-	VSS	-	-	-	-	-	VSS	-	-	-
K7	THERMAL-BALL (Note 3)	-	VSS	-	-	-	-	-	VSS	-	-	-
K8	THERMAL-BALL (Note 3)	-	VSS	-	-	-	-	-	VSS	-	-	-
K9	THERMAL-BALL (Note 3)	-	VSS	-	-	-	-	-	VSS	-	-	-
K10	THERMAL-BALL (Note 3)	-	VSS	-	-	-	-	-	VSS	-	-	-
K11	THERMAL-BALL (Note 3)	-	VSS	-	-	-	-	-	VSS	-	-	-
K12	VSS	-	VSS	-	-	-	-	-	VSS	-	-	-
K13	P76/RTDACK/CTX1/NBDD2	P76	RTDACK	CTX1 (Note 1)	NBDD2	Input/Output	VCCE	-	P76	Input	Hi-Z	Hi-Z
K14	P77/RTDCLK/CRX1/NBDD3	P77	RTDCLK	CRX1 (Note 1)	NBDD3	Input/Output	VCCE	-	P77	Input	Hi-Z	Hi-Z
K15	P93/TO16/SCLK15/SCLKO5	P93	TO16	SCLK15/ SCLKO5	-	Input/Output	VCCE	-	P93	Input	Hi-Z	Hi-Z
L1	P03/DB3/TO24/DD3	P03	DB3	TO24 (Note 1)	DD3 (Note 1)	Input/Output	VCC-BUS	During single-chip and external extension modes	P03	Input	Hi-Z	Hi-Z
								During processor mode	DB3	Input/Output	Hi-Z	Hi-Z
L2	P04/DB4/TO25/DD4	P04	DB4	TO25 (Note 1)	DD4 (Note 1)	Input/Output	VCC-BUS	During single-chip and external extension modes	P04	Input	Hi-Z	Hi-Z
								During processor mode	DB4	Input/Output	Hi-Z	Hi-Z
L3	P05/DB5/TO26/DD5	P05	DB5	TO26 (Note 1)	DD5 (Note 1)	Input/Output	VCC-BUS	During single-chip and external extension modes	P05	Input	Hi-Z	Hi-Z
								During processor mode	DB5	Input/Output	Hi-Z	Hi-Z
L4	P02/DB2/TO23/DD2	P02	DB2	TO23 (Note 1)	DD2 (Note 1)	Input/Output	VCC-BUS	During single-chip and external extension modes	P02	Input	Hi-Z	Hi-Z
								During processor mode	DB2	Input/Output	Hi-Z	Hi-Z
L5	THERMAL-BALL (Note 3)	-	VSS	-	-	-	-	-	VSS	-	-	-
L6	THERMAL-BALL (Note 3)	-	VSS	-	-	-	-	-	VSS	-	-	-
L7	THERMAL-BALL (Note 3)	-	VSS	-	-	-	-	-	VSS	-	-	-
L8	THERMAL-BALL (Note 3)	-	VSS	-	-	-	-	-	VSS	-	-	-
L9	THERMAL-BALL (Note 3)	-	VSS	-	-	-	-	-	VSS	-	-	-
L10	THERMAL-BALL (Note 3)	-	VSS	-	-	-	-	-	VSS	-	-	-
L11	THERMAL-BALL (Note 3)	-	VSS	-	-	-	-	-	VSS	-	-	-
L12	N.C.	-	-	-	-	-	-	-	-	-	-	-
L13	P73/HACK#/TIN26	P73	HACK#	TIN26	-	Input/Output	VCCE	-	P73	Input	Hi-Z	Hi-Z
L14	P74/RTDXTD/TXD3/NBDD0	P74	RTDXTD	TXD3 (Note 1)	NBDD0	Input/Output	VCCE	-	P74	Input	Hi-Z	Hi-Z
L15	P75/RTDRXD/RXD3/NBDD1	P75	RTDRXD	RXD3 (Note 1)	NBDD1	Input/Output	VCCE	-	P75	Input	Hi-Z	Hi-Z
M1	P06/DB6/TO27/DD6	P06	DB6	TO27 (Note 1)	DD6 (Note 1)	Input/Output	VCC-BUS	During single-chip and external extension modes	P06	Input	Hi-Z	Hi-Z
								During processor mode	DB6	Input/Output	Hi-Z	Hi-Z
M2	P07/DB7/TO28/DD7	P07	DB7	TO28 (Note 1)	DD7 (Note 1)	Input/Output	VCC-BUS	During single-chip and external extension modes	P07	Input	Hi-Z	Hi-Z
								During processor mode	DB7	Input/Output	Hi-Z	Hi-Z
M3	P10/DB8/TO29/DD8	P10	DB8	TO29 (Note 1)	DD8 (Note 1)	Input/Output	VCC-BUS	During single-chip and external extension modes	P10	Input	Hi-Z	Hi-Z
								During processor mode	DB8	Input/Output	Hi-Z	Hi-Z
M4	VREF0	-	VREF0	-	-	-	AVCC0	-	VREF0	-	-	-
M5	AD0IN2	-	AD0IN2	-	-	Input	AVCC0	-	AD0IN2	Input	Hi-Z	Hi-Z
M6	AD0IN6	-	AD0IN6	-	-	Input	AVCC0	-	AD0IN6	Input	Hi-Z	Hi-Z
M7	AD0IN10	-	AD0IN10	-	-	Input	AVCC0	-	AD0IN10	Input	Hi-Z	Hi-Z
M8	AD0IN14	-	AD0IN14	-	-	Input	AVCC0	-	AD0IN14	Input	Hi-Z	Hi-Z
M9	AD0IN15	-	AD0IN15	-	-	Input	AVCC0	-	AD0IN15	Input	Hi-Z	Hi-Z
M10	N.C.	-	-	-	-	-	-	-	-	-	-	-
M11	P174/TXD2/TO28	P174	TXD2	TO28 (Note 1)	-	Input/Output	VCCE	-	P174	Input	Hi-Z	Hi-Z
M12	VCCE	-	VCCE	-	-	-	-	-	VCCE	-	-	-
M13	P70/CLKOUT/WR#/BCLK	P70	CLKOUT/ WR#	BCLK	-	Input/Output	VCCE	-	P70	Input	Hi-Z	Hi-Z
M14	P71/WAIT#	P71	WAIT#	-	-	Input/Output	VCCE	-	P71	Input	Hi-Z	Hi-Z
M15	P72/HREQ#/TIN27	P72	HREQ#	TIN27	-	Input/Output	VCCE	-	P72	Input	Hi-Z	Hi-Z
N1	P11/DB9/TO30/DD9	P11	DB9	TO30 (Note 1)	DD9 (Note 1)	Input/Output	VCC-BUS	During single-chip and external extension modes	P11	Input	Hi-Z	Hi-Z
								During processor mode	DB9	Input/Output	Hi-Z	Hi-Z
N2	P12/DB10/TO31/DD10	P12	DB10	TO31 (Note 1)	DD10 (Note 1)	Input/Output	VCC-BUS	During single-chip and external extension modes	P12	Input	Hi-Z	Hi-Z
								During processor mode	DB10	Input/Output	Hi-Z	Hi-Z
N3	P15/DB13/TO34/DD13	P15	DB13	TO34 (Note 1)	DD13 (Note 1)	Input/Output	VCC-BUS	During single-chip and external extension modes	P15	Input	Hi-Z	Hi-Z
								During processor mode	DB13	Input/Output	Hi-Z	Hi-Z
N4	N.C.	-	-	-	-	-	-	-	-	-	-	-
N5	AVCC0	-	AVCC0	-	-	-	-	-	AVCC0	-	-	-
N6	AD0IN3	-	AD0IN3	-	-	Input	AVCC0	-	AD0IN3	Input	Hi-Z	Hi-Z
N7	AD0IN7	-	AD0IN7	-	-	Input	AVCC0	-	AD0IN7	Input	Hi-Z	Hi-Z
N8	AD0IN11	-	AD0IN11	-	-	Input	AVCC0	-	AD0IN11	Input	Hi-Z	Hi-Z
N9	VSS	-	VSS	-	-	-	-	-	VSS	-	-	-
N10	N.C.	-	-	-	-	-	-	-	-	-	-	-
N11	P82/TXD0/TO26	P82	TXD0	TO26 (Note 1)	-	Input/Output	VCCE	-	P82	Input	Hi-Z	Hi-Z
N12	P85/TXD1/TO23	P85	TXD1	TO23 (Note 1)	-	Input/Output	VCCE	-	P85	Input	Hi-Z	Hi-Z
N13	P87/SCLK11/ SCLKO1/TO21	P87	SCLK11/ SCLKO1	TO21 (Note 1)	-	Input/Output	VCCE	-	P87	Input	Hi-Z	Hi-Z
N14	P63	P63	-	-	-	Input/Output	VCCE	-	P63	Input	Hi-Z	Hi-Z
N15	SBI#	-	SBI#	-	-	Input	VCCE	-	SBI#	Input	Hi-Z	Hi-Z
P1	N.C.	-	-	-	-	-	-	-	-	-	-	-
P2	P13/DB11/TO32/DD11	P13	DB11	TO32 (Note 1)	DD11 (Note 1)	Input/Output	VCC-BUS	During single-chip and external extension modes	P13	Input	Hi-Z	Hi-Z
								During processor mode	DB11	Input/Output	Hi-Z	Hi-Z
P3	P16/DB14/TO35/DD14	P16	DB14	TO35 (Note 1)	DD14 (Note 1)	Input/Output	VCC-BUS	During single-chip and external extension modes	P16	Input	Hi-Z	Hi-Z
								During processor mode	DB14	Input/Output	Hi-Z	Hi-Z
P4	P17/DB15/TO36/DD15	P17	DB15	TO36 (Note 1)	DD15 (Note 1)	Input/Output	VCC-BUS	During single-chip and external extension modes	P17	Input	Hi-Z	Hi-Z
								During processor mode	DB15	Input/Output	Hi-Z	Hi-Z
P5	AD0IN0	-	AD0IN0	-	-	Input	AVCC0	-	AD0IN0	Input	Hi-Z	Hi-Z
P6	AD0IN4	-	AD0IN4	-	-	Input	AVCC0	-	AD0IN4	Input	Hi-Z	Hi-Z
P7	AD0IN8	-	AD0IN8	-	-	Input	AVCC0	-	AD0IN8	Input	Hi-Z	Hi-Z
P8	AD0IN12	-	AD0IN12	-	-	Input	AVCC0	-	AD0IN12	Input	Hi-Z	Hi-Z

Note 1: The pins outputted at two places.

Note 2: The JTCK, JTDI, JTDO and JTMS pins are reset by input from the JTRST pin, and not reset from the RESET# pin.

Note 3: THERMAL BALL must be connected to the ground (GND).

Table 1.4.2 Pin Assignments of the M32192F8xWG (4/4)

Pin No.	Symbol	Function				Type	Power supply	Condition	Pin state when reset			
		Port	Function 1	Function 2	DRI function NBD function				Function	Type	State during reset	State upon exiting reset
P9	EXCVCC	-	EXCVCC	-	-	-	-	-	EXCVCC	-	-	-
P10	N.C.	-	-	-	-	-	-	-	-	-	-	-
P11	VCCER	-	VCCER	-	-	Input/Output	-	-	VCCER	-	-	-
P12	P84/SCLKI0/ SCLKO0/TO24	-	SCLKI0/ SCLKO0	-	-	Input/Output	VCCE	-	P84	Input	Hi-Z	Hi-Z
P13	N.C.	-	-	-	-	-	-	-	-	-	-	-
P14	P62	P62	-	-	-	Input/Output	VCCE	-	P62	Input	Hi-Z	Hi-Z
P15	P61	P61	-	-	-	Input/Output	VCCE	-	P61	Input	Hi-Z	Hi-Z
R1	N.C.	-	-	-	-	-	-	-	-	-	-	-
R2	P14/DB12/ TO33/DD12	P14	DB12	TO33 (Note 1)	DD12 (Note 1)	Input/Output	VCC-BUS	During single-chip and external extension modes	P14	Input	Hi-Z	Hi-Z
								During processor mode	DB12	Input/Output	Hi-Z	Hi-Z
R3	N.C.	-	-	-	-	-	-	-	-	-	-	-
R4	VSS	-	VSS	-	-	-	-	-	VSS	-	-	-
R5	AD0IN1	-	AD0IN1	-	-	Input	AVCC0	-	AD0IN1	Input	Hi-Z	Hi-Z
R6	AD0IN5	-	AD0IN5	-	-	Input	AVCC0	-	AD0IN5	Input	Hi-Z	Hi-Z
R7	AD0IN9	-	AD0IN9	-	-	Input	AVCC0	-	AD0IN9	Input	Hi-Z	Hi-Z
R8	AD0IN13	-	AD0IN13	-	-	Input	AVCC0	-	AD0IN13	Input	Hi-Z	Hi-Z
R9	AVSS0	-	AVSS0	-	-	-	-	-	AVSS0	-	-	-
R10	N.C.	-	-	-	-	-	-	-	-	-	-	-
R11	P175/RXD2/TO27	P175	RXD2	TO27 (Note 1)	-	Input/Output	VCCE	-	P175	Input	Hi-Z	Hi-Z
R12	P83/RXD0/TO25	P83	RXD0	TO25 (Note 1)	-	Input/Output	VCCE	-	P83	Input	Hi-Z	Hi-Z
R13	P86/RXD1/TO22	P86	RXD1	TO22 (Note 1)	-	Input/Output	VCCE	-	P86	Input	Hi-Z	Hi-Z
R14	VSS	-	VSS	-	-	-	-	-	VSS	-	-	-
R15	EXCVDD	-	EXCVDD	-	-	-	-	-	EXCVDD	-	-	-

Note 1: The pins outputted at two places.

Note 2: The JTCK, JTDI, JTDO and JTMS pins are reset by input from the JTRST pin, and not reset from the RESET# pin.

Note 3: THERMAL BALL must be connected to the ground (GND).

# CHAPTER 2

---

## CPU

- 2.1 CPU Registers
- 2.2 General-purpose Registers
- 2.3 Control Registers
- 2.4 Accumulator
- 2.5 Program Counter
- 2.6 Data Formats
- 2.7 Supplementary Explanation for BSET, BCLR,  
LOCK and UNLOCK Instruction Execution

## 2.1 CPU Registers

The M32R-FPU has 16 general-purpose registers, 6 control registers, an accumulator and a program counter. The accumulator is of 56-bit configuration, and all other registers are of 32-bit configuration.

## 2.2 General-purpose Registers

The 16 general-purpose registers (R0–R15) are of 32-bit width and are used to retain data and base address, as well as for integer calculations, floating-point operations, etc. R14 is used as the link register and R15 as the stack pointer. The link register is used to store the return address when executing a subroutine call instruction. The Interrupt Stack Pointer (SPI) and the User Stack Pointer (SPU) are alternately represented by R15 depending on the value of the Stack Mode (SM) bit in the Processor Status Word Register (PSW).

Upon exiting the reset state, the value of the general-purpose registers is undefined.

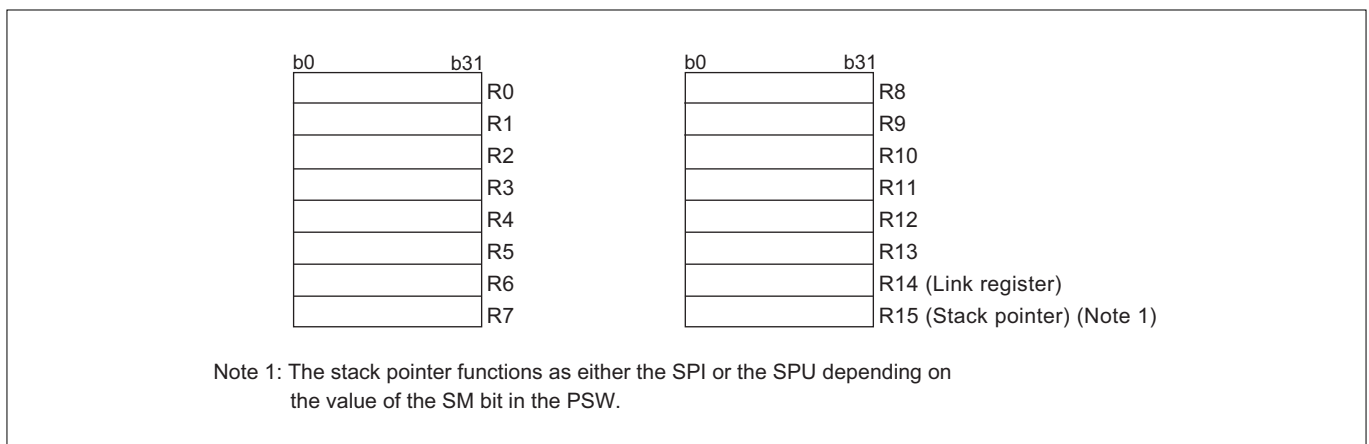


Figure 2.2.1 General-purpose Registers

## 2.3 Control Registers

There are 6 control registers which are the Processor Status Word Register (PSW), the Condition Bit Register (CBR), the Interrupt Stack Pointer (SPI), the User Stack Pointer (SPU), the Backup PC (BPC) and the Floating-point Status Register (FPSR).

The dedicated MVTC and MVFC instructions are used for writing and reading these control registers.

In addition, the SM bit, IE bit and C bit of the PSW can also be set by the SETPSW or CLRPSW instruction.

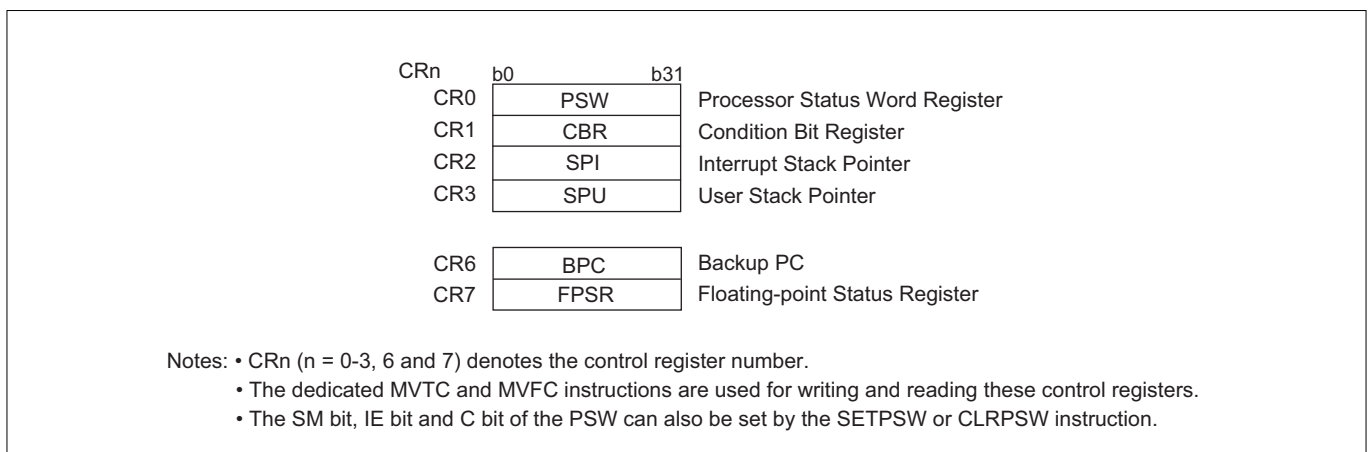
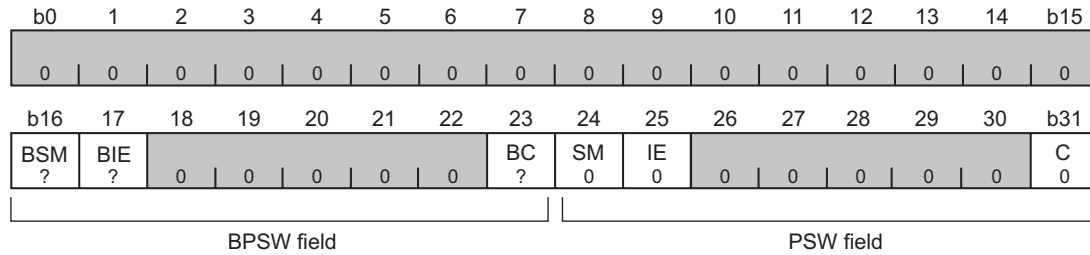


Figure 2.3.1 Control Registers

## 2.3.1 Processor Status Word Register: PSW (CR0)



&lt;Upon exiting reset: B'0000 0000 0000 0000 ??00 000? 0000 0000&gt;

b	Bit Name	Function	R	W
0–15	No function assigned. Fix to "0."		0	0
16	BSM Backup SM Bit	Saves value of SM bit when EIT occurs	R	W
17	BIE Backup IE Bit	Saves value of IE bit when EIT occurs	R	W
18–22	No function assigned. Fix to "0."		0	0
23	BC Backup C Bit	Saves value of C bit when EIT occurs	R	W
24	SM Stack Mode Bit	0: Uses R15 as the interrupt stack pointer 1: Uses R15 as the user stack pointer	R	W
25	IE Interrupt Enable Bit (Note 1)	0: Does not accept interrupt 1: Accepts interrupt	R	W
26–30	No function assigned. Fix to "0."		0	0
31	C Condition Bit	Indicates carry, borrow or overflow resulting from operations (instruction dependent)	R	W

Note 1: Interrupt which is controllable is External Interrupt (EI). Reserved Instruction Exception (RIE), Address Exept (AE), Reset Interrupt (RI), System Break Interrupt (SBI) and Trap are not controlled.

The Processor Status Word Register (PSW) indicates the M32R-FPU status. It consists of the current PSW field which is regularly used, and the BPSW field where a copy of the PSW field is saved when EIT occurs. The PSW field consists of the Stack Mode (SM) bit, the Interrupt Enable (IE) bit and the Condition (C) bit. The BPSW field consists of the Backup Stack Mode (BSM) bit, the Backup Interrupt Enable (BIE) bit and the Backup Condition (BC) bit.

Upon exiting the reset state, BSM, BIE and BC are undefined. All other bits are "0."

### 2.3.2 Condition Bit Register: CBR (CR1)

The Condition Bit Register (CBR) is derived from the PSW register by extracting its Condition (C) bit. The value written to the PSW register's C bit is reflected in this register. The register can only be read. (Writing to the register with the MVTC instruction is ignored.)

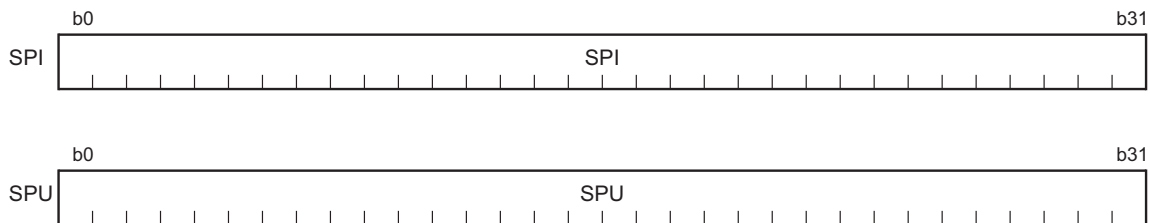
Upon exiting the reset state, the value of CBR is H'0000 0000.



### 2.3.3 Interrupt Stack Pointer: SPI (CR2) and User Stack Pointer: SPU (CR3)

The Interrupt Stack Pointer (SPI) and the User Stack Pointer (SPU) retain the address of the current stack pointer. These registers can be accessed as the general-purpose register R15. R15 switches between representing the SPI and SPU depending on the value of the Stack Mode (SM) bit in the PSW.

Upon exiting the reset state, the values of the SPI and SPU are undefined.

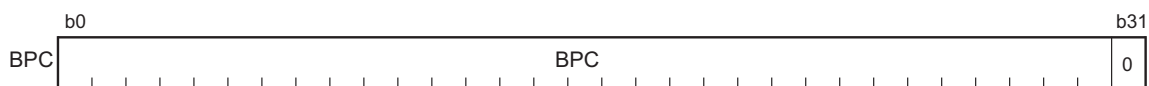


### 2.3.4 Backup PC: BPC (CR6)

The Backup PC (BPC) is used to save the value of the Program Counter (PC) when an EIT occurs. Bit 31 is fixed to "0."

When an EIT occurs, the register sets either the PC value when the EIT occurred or the PC value for the next instruction depending on the type of EIT. The BPC value is loaded to the PC when the RTE instruction is executed. However, the values of the lower 2 bits of the PC are always "00" when returned. (PC always returns to the word-aligned address.)

Upon exiting the reset state, the value of the BPC is undefined.





## 2.3.5 Floating-point Status Register: FPSR (CR7)

b0	1	2	3	4	5	6	7	8	9	10	11	12	13	14	b15
FS	FX	FU	FZ	FO	FV	0	0	0	0	0	0	0	0	0	0
0	0	0	0	0	0	0	0	0	0	0	0	0	0	0	0
b16	17	18	19	20	21	22	23	24	25	26	27	28	29	30	b31
	EX	EU	EZ	EO	EV		DN	CE	CX	CU	CZ	CO	CV	RM	
0	0	0	0	0	0	0	1	0	0	0	0	0	0	0	0

&lt;Upon exiting reset: H'0000 0100&gt;

b	Bit Name	Function	R	W
0	FS Floating-point Exception Summary Bit	Reflects the logical sum of FU, FZ, FO and FV.	R	–
1	FX Inexact Exception Flag	Set to "1" when an inexact exception occurs (if EIT processing is unexecuted (Note 1)). Once set, the flag retains the value "1" until it is cleared to "0" in software.	R	W
2	FU Underflow Exception Flag	Set to "1" when an underflow exception occurs (if EIT processing is unexecuted (Note 1)). Once set, the flag retains the value "1" until it is cleared to "0" in software.	R	W
3	FZ Zero Divide Exception Flag	Set to "1" when a zero divide exception occurs (if EIT processing is unexecuted (Note 1)). Once set, the flag retains the value "1" until it is cleared to "0" in software.	R	W
4	FO Overflow Exception Flag	Set to "1" when an overflow exception occurs (if EIT processing is unexecuted (Note 1)). Once set, the flag retains the value "1" until it is cleared to "0" in software.	R	W
5	FV Invalid Operation Exception Flag	Set to "1" when an invalid operation exception occurs (if EIT processing is unexecuted (Note 1)). Once set, the flag retains the value "1" until it is cleared to "0" in software.	R	W
6–16	No function assigned. Fix to "0."		0	0
17	EX Inexact Exception Enable Bit	0: Mask EIT processing to be executed when an inexact exception occurs. 1: Execute EIT processing when an inexact exception occurs.	R	W
18	EU Underflow Exception Enable Bit	0: Mask EIT processing to be executed when an underflow exception occurs. 1: Execute EIT processing when an underflow exception occurs.	R	W
19	EZ Zero Divide Exception Enable Bit	0: Mask EIT processing to be executed when a zero divide exception occurs. 1: Execute EIT processing when a zero divide exception occurs.	R	W
20	EO Overflow Exception Enable Bit	0: Mask EIT processing to be executed when an overflow exception occurs. 1: Execute EIT processing when an overflow exception occurs.	R	W
21	EV Invalid Operation Exception Enable Bit	0: Mask EIT processing to be executed when an invalid operation exception occurs. 1: Execute EIT processing when an invalid operation exception occurs.	R	W
22	No function assigned. Fix to "0."		0	0
23	DN Denormalized Number Zero Flush Bit (Note 2)	0: Handle the denormalized number as a denormalized number. 1: Handle the denormalized number as zero.	R	W
24	CE Unimplemented Operation Exception Cause Bit	0: No unimplemented operation exception occurred. 1: An unimplemented operation exception occurred. When the bit is set to "1", the execution of an FPU operation instruction will clear it to "0."	R (Note 3)	
25	CX Inexact Exception Cause Bit	0: No inexact exception occurred. 1: An inexact exception occurred. When the bit is set to "1", the execution of an FPU operation instruction will clear it to "0."	R (Note 3)	

26	CU Underflow Exception Cause Bit	0: No underflow exception occurred 1: An underflow exception occurred. When the bit is set to "1", the execution of an FPU operation instruction will clear it to "0."	R (Note 3)
27	CZ Zero Divide Exception Cause Bit	0: No zero divide exception occurred. 1: A zero divide exception occurred. When the bit is set to "1", the execution of an FPU operation instruction will clear it to "0."	R (Note 3)
28	CO Overflow Exception Cause Bit	0: No overflow exception occurred. 1: An overflow exception occurred. When the bit is set to "1", the execution of an FPU operation instruction will clear it to "0."	R (Note 3)
29	CV Invalid Operation Exception Cause Bit	0: No invalid operation exception occurred. 1: An invalid operation exception occurred. When the bit is set to "1", the execution of an FPU operation instruction will clear it to "0."	R (Note 3)
30, 31	RM Rounding Mode Selection Bit	00: Round to nearest 01: Round toward Zero 10: Round toward + Infinity 11: Round toward – Infinity	R W

Note 1: The phrase "If EIT processing unexecuted" means whenever one of the exceptions occurs, enable bits 17 to 21 are set to "0" which masks the EIT processing so that it cannot be executed. If two exceptions occur at the same time and their corresponding exception enable bits are set differently (one enabled, and the other masked), EIT processing is executed. In this case, these two flags do not change state regardless of the enable bits settings.

Note 2: If a denormalized number is given to the operand when DN = "0", an unimplemented exception occurs.

Note 3: This bit is cleared by writing "0." Writing "1" has no effect (the bit retains the value it had before the write).

## 2.4 Accumulator

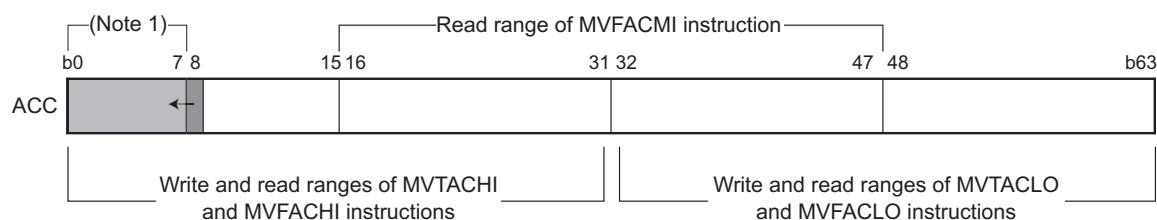
The Accumulator (ACC) is a 56-bit register used for DSP function instructions.

The accumulator is handled as a 64-bit register when accessed for read or write. When reading data from the accumulator, the value of bit 8 is sign-extended. When writing data to the accumulator, bits 0 to 7 are ignored. The accumulator is also used for the multiply instruction "MUL," in which case the accumulator value is destroyed by instruction execution.

Use the MVTACHI and MVTACLO instructions for writing to the accumulator. The MVTACHI and MVTACLO instructions write data to the high-order 32 bits (bits 0–31) and the low-order 32 bits (bits 32–63), respectively.

Use the MVFACHI, MVFACLO and MVFACMI instructions for reading data from the accumulator. The MVFACHI, MVFACLO and MVFACMI instructions read data from the high-order 32 bits (bits 0–31), the low-order 32 bits (bits 32–63) and the middle 32 bits (bits 16–47), respectively.

Upon exiting the reset state, the value of accumulator is undefined.

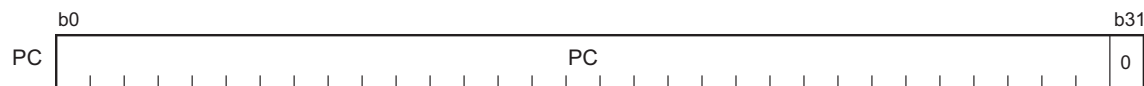


Note 1: When read, bits 0 to 7 always show the sign-extended value of the value of bit 8. Writing to this bit field is ignored.

## 2.5 Program Counter

The Program Counter (PC) is a 32-bit counter that retains the address of the instruction being executed. Since the M32R FPU instruction starts with even-numbered addresses, the LSB (bit 31) is always "0."

Upon exiting the reset state, the value of PC is H'0000 0000.



## 2.6 Data Formats

### 2.6.1 Data Types

The data types that can be handled by the M32R-FPU instruction set are signed or unsigned 8, 16 and 32-bit integers and single-precision floating-point numbers. The signed integers are represented by 2's complements.

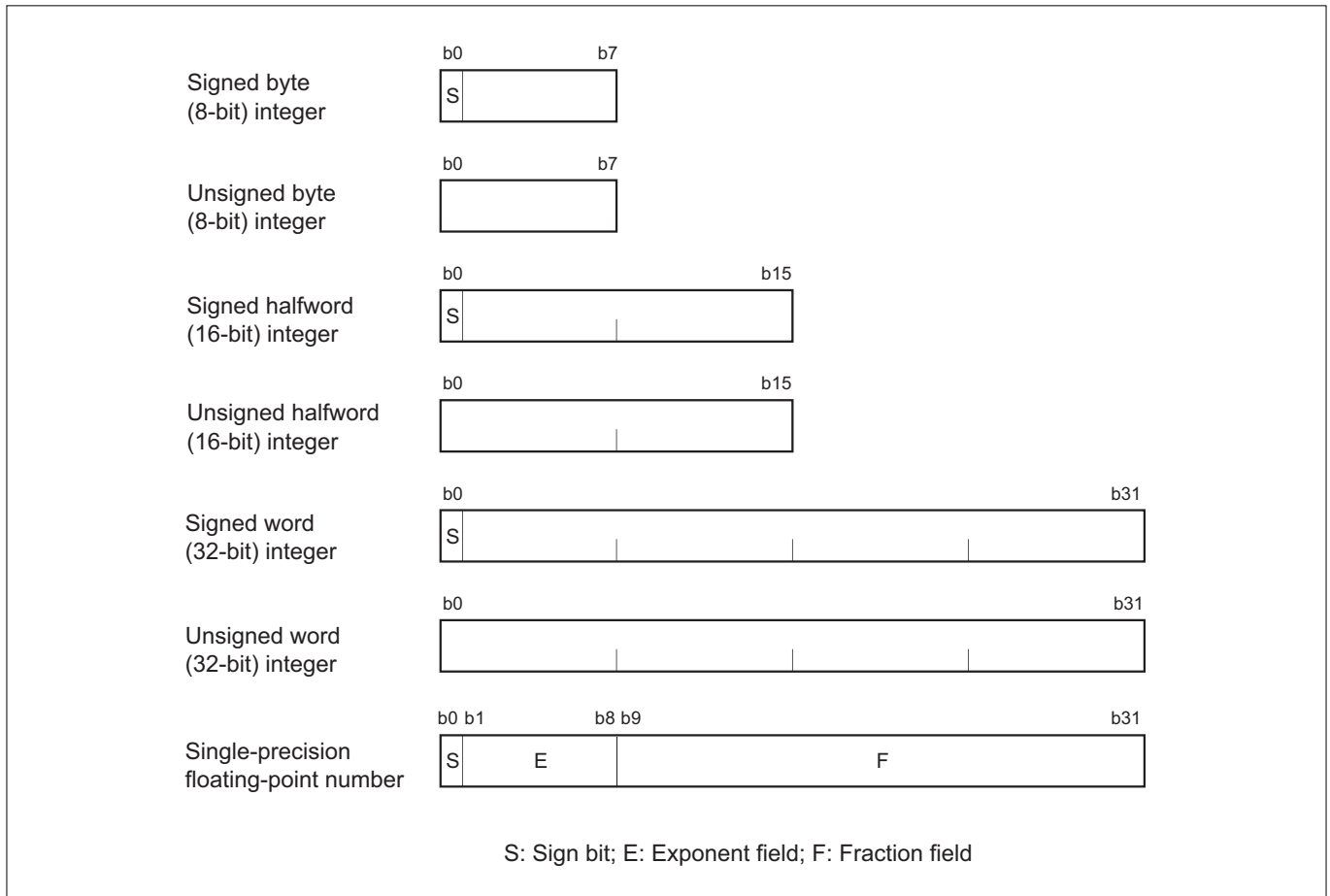


Figure 2.6.1 Data Types

## 2.6.2 Data Formats

### (1) Data formats in registers

The data sizes in the M32R-FPU registers are always words (32 bits).

When loading byte (8-bit) or halfword (16-bit) data from memory into a register, the data is sign-extended (LDB, LDH instructions) or zero-extended (LDUB, LDUH instructions) to a word (32-bit) quantity before being loaded in the register.

When storing data from a register into a memory, the 32-bit data, the 16-bit data on the LSB side and the 8-bit data on the LSB side of the register are stored into memory by the ST, STH and STB instructions, respectively.

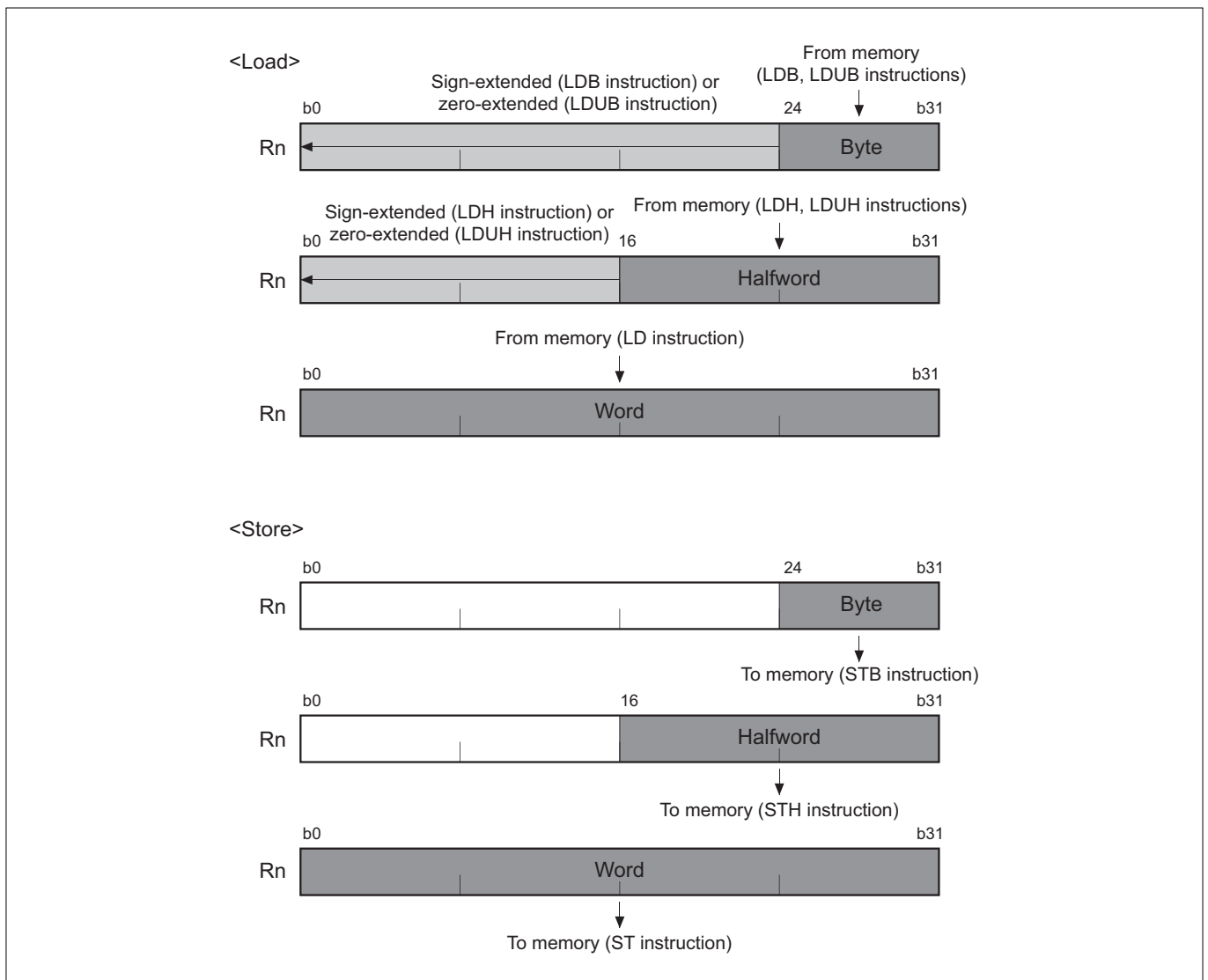
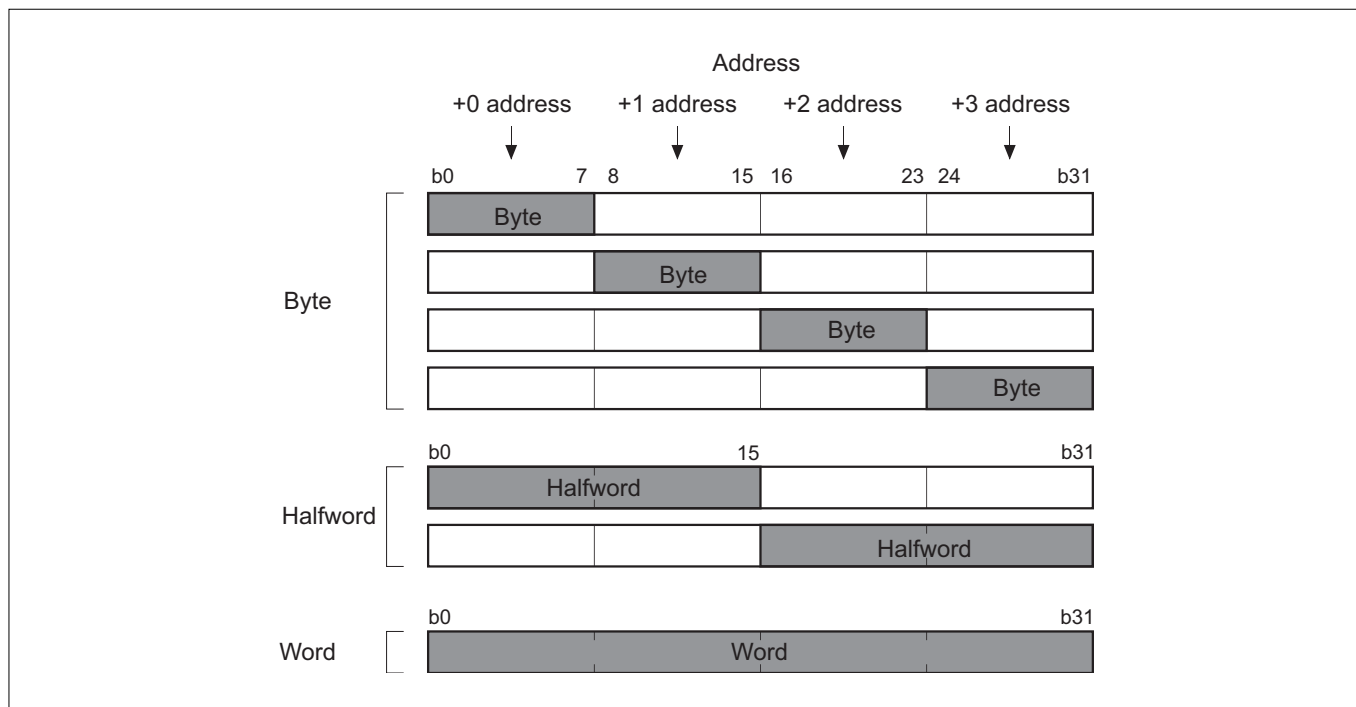


Figure 2.6.2 Data Formats in Registers

### (2) Data formats in memory

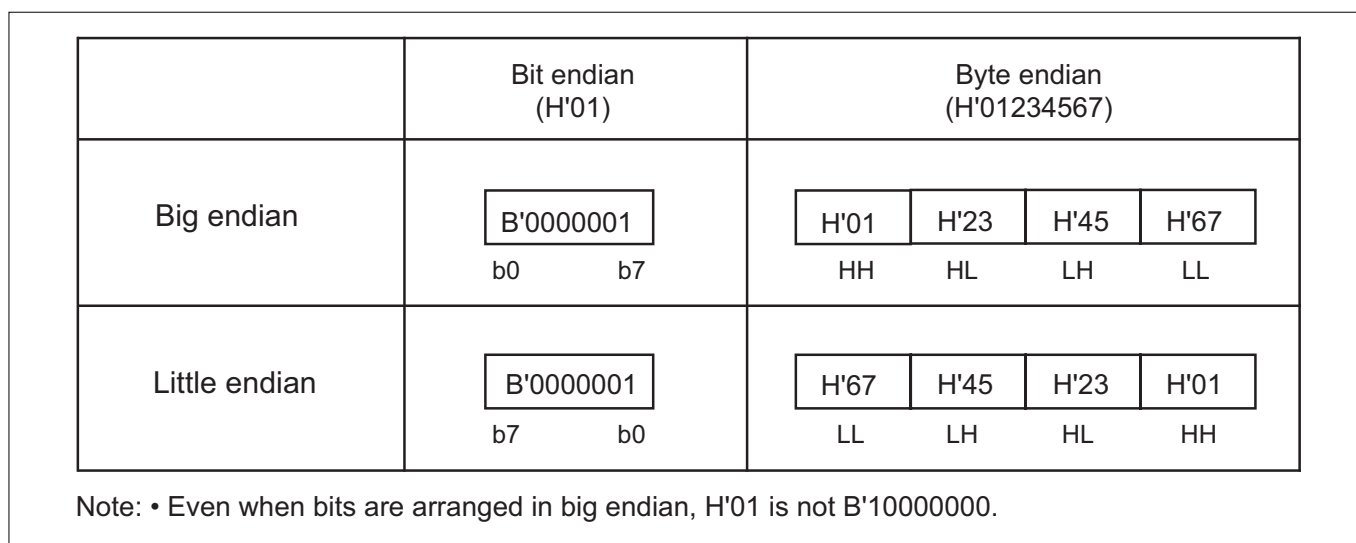
The data sizes in memory can be byte (8 bits), halfword (16 bits) or word (32 bits). Although byte data can be located at any address, halfword and word data must be located at the addresses aligned with a halfword boundary (least significant address bit = "0") or a word boundary (two low-order address bits = "00"), respectively. If an attempt is made to access memory data that overlaps the halfword or word boundary, an address exception occurs.



**Figure 2.6.3 Data Formats in Memory**

### (3) Endian

The diagrams below show a general endian system and the endian adopted for the M32R Family micro-computers.



**Figure 2.6.4 General Endian System**

Microcomputer family name	7700 and M16C Families		<u>M32R Family</u>
Endian (bit/byte)	Little/little	Little/big	Big/big
Address	+0 +1 +2 +3	+0 +1 +2 +3	+0 +1 +2 +3
Data arrangement			
Bit number	7-0 15-8 23-16 31-24	31-24 23-16 15-8 7-0	0-7 8-15 16-23 24-31
Example: 0x01234567	.byte 67,45,23,01	.byte 01,23,45,67	.byte 01,23,45,67

Note: • The M32R Family uses the big endian for both bits and bytes.

Figure 2.6.5 Endian Adopted for the M32R Family

(4) Transfer instructions

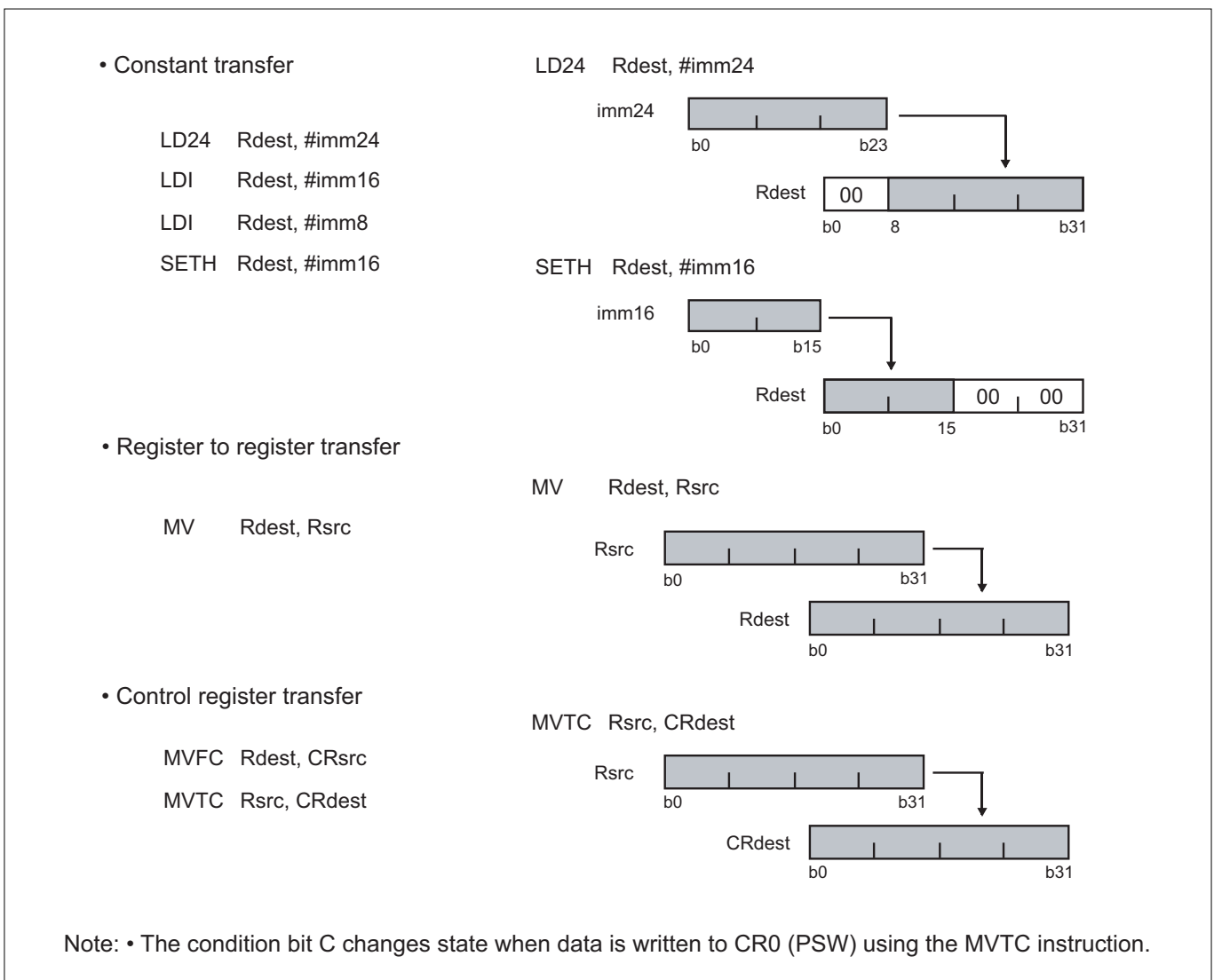


Figure 2.6.6 Transfer Instructions

## (5) Transfer from memory (signed) to registers

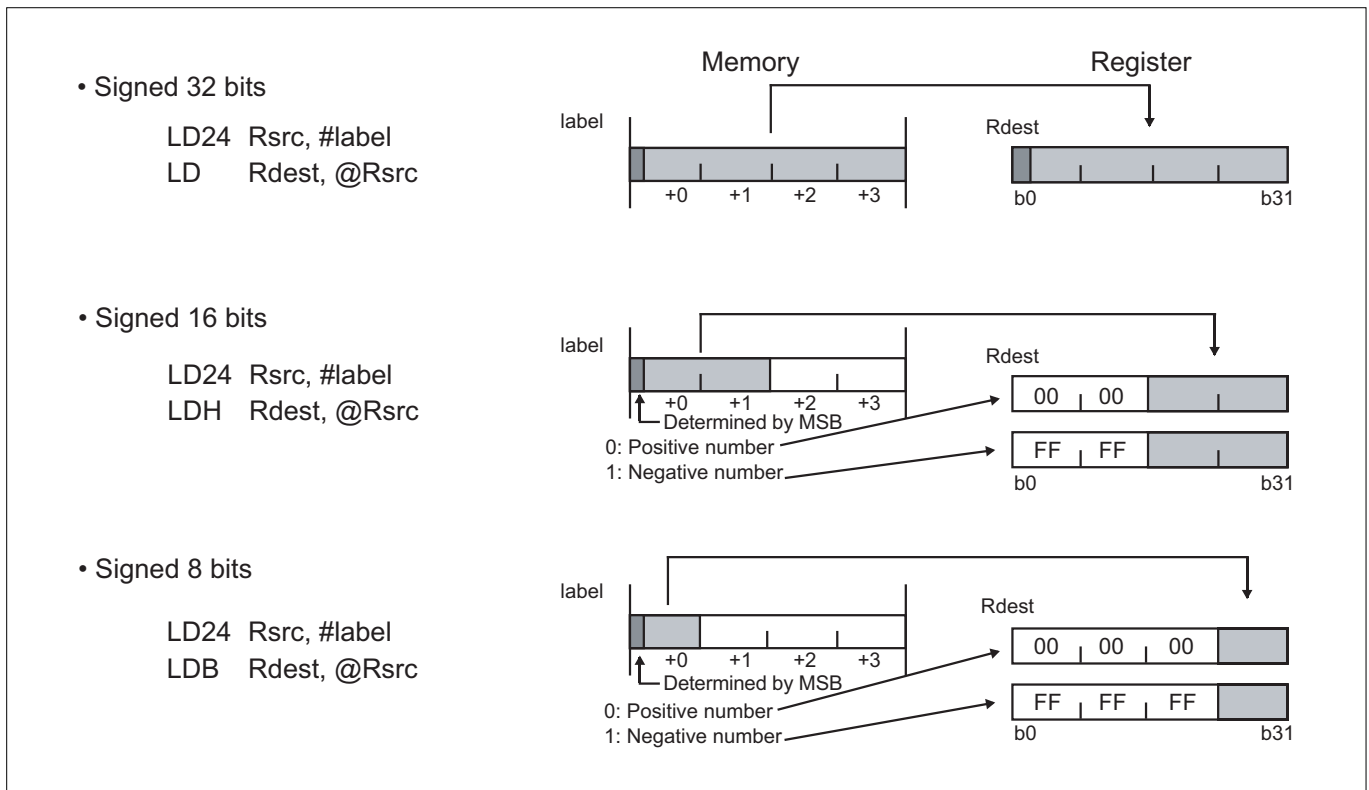


Figure 2.6.7 Transfer from Memory (Signed) to Registers

## (6) Transfer from memory (unsigned) to registers

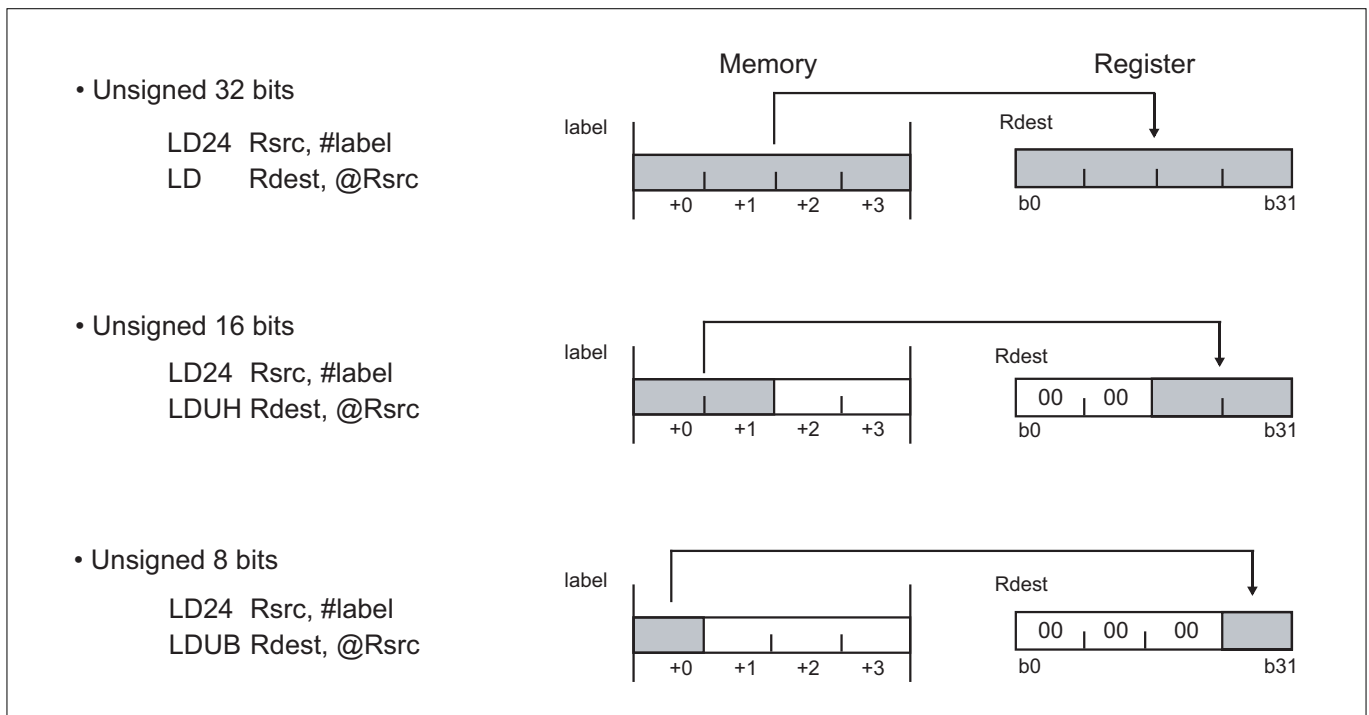


Figure 2.6.8 Transfer from Memory (Unsigned) to Registers



(7) Notes on data transfer

When transferring data, be aware that data arrangements in registers and memory are different.

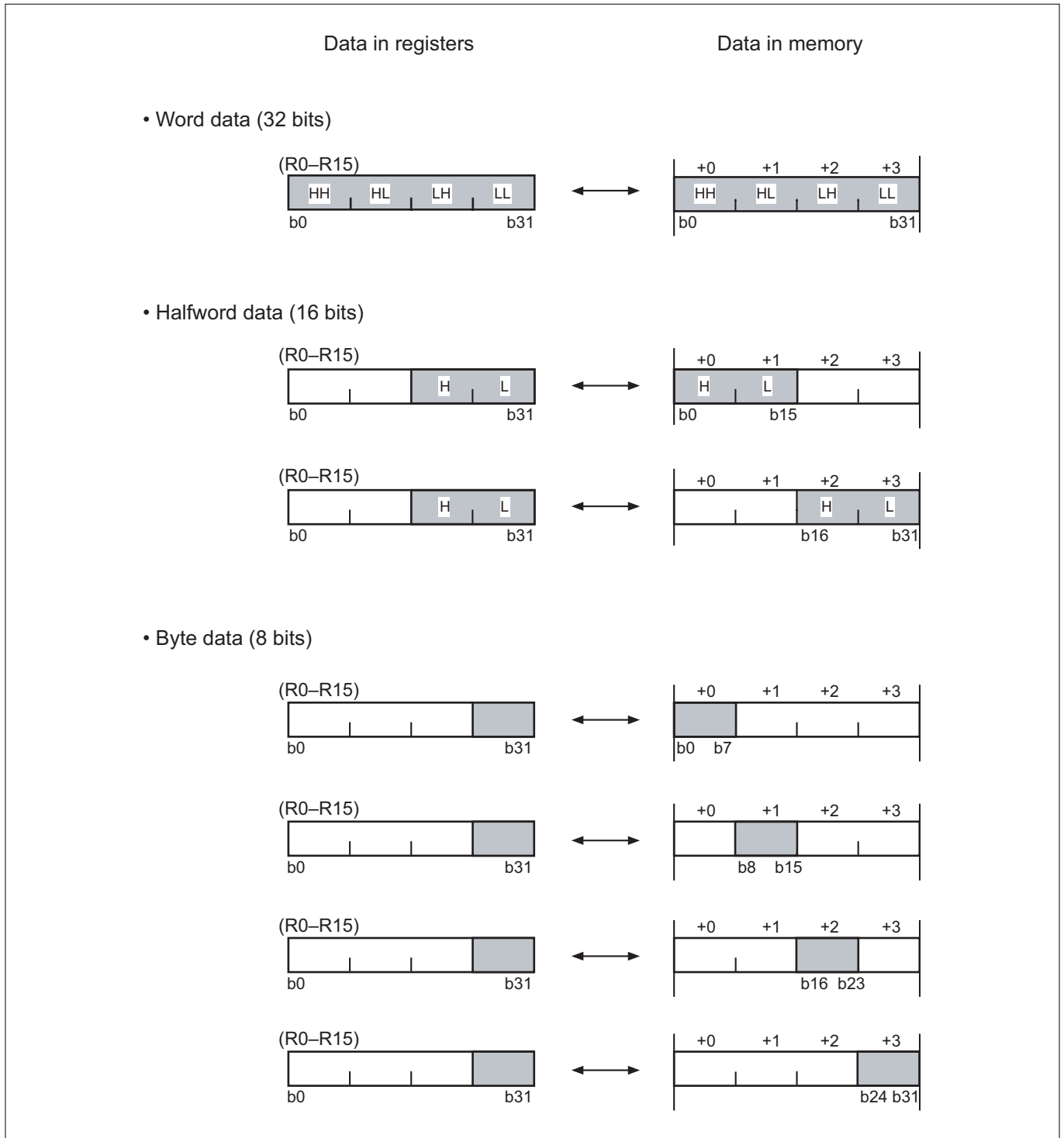


Figure 2.6.9 Differences in Data Arrangements

## 2.7 Supplementary Explanation for BSET, BCLR, LOCK and UNLOCK Instruction Execution

The LOCK bit is set when executing the BSET or BCLR instruction, and is cleared when the BSET or BCLR instruction finishes.

The LOCK instruction sets the LOCK bit, as well as performs an ordinary load operation. The UNLOCK instruction is used to clear the LOCK bit.

The LOCK bit is located inside the CPU, and cannot directly be accessed for read or write by users. This bit controls granting of bus control requested by devices other than the CPU.

- When LOCK bit = "0"  
Control of the bus requested by devices other than the CPU is granted
- When LOCK bit = "1"  
Control of the bus requested by devices other than the CPU is denied

In the 32192/32195/32196 Group, control of the bus may be requested by devices other than the CPU in the following two cases:

- When DMA transfer is requested by the internal DMAC
- When HREQ# input is pulled low to request that the CPU be placed in a hold state

## **CHAPTER 3**

---

# **ADDRESS SPACE**

- 3.1 Outline of the Address Space
- 3.2 Operation Modes
- 3.3 Internal ROM and External Extension Areas
- 3.4 Internal RAM and SFR Areas
- 3.5 EIT Vector Entry
- 3.6 ICU Vector Table
- 3.7 Notes on Address Space

### 3.1 Outline of the Address Space

The logical addresses of the M32R are always handled in 32 bits, providing a linear address space of up to 4 Gbytes. The address space of the M32R/ECU consists of the following:

#### (1) User space

- Internal ROM area
- External extension area
- Internal RAM area
- SFR (Special Function Register) area

The 2 Gbytes from the address H'0000 0000 to the address H'7FFF FFFF comprise the user space. Located in this space are the internal ROM area, an external extension area, the internal RAM area and the SFR (Special Function Register) area (in which a set of internal peripheral I/O registers exist). Of these, the internal ROM and external extension areas are located differently depending on mode settings as will be described later.

#### (2) System space (This area is closed to the user)

The 2 Gbytes from the address H'8000 0000 to the address H'FFFF FFFF comprise the system space. This space (except for SFR area for NBD control) is reserved for use by development tools such as an in-circuit emulator and debug monitor.

## 3.2 Operation Modes

The microcomputer is placed in one of the following modes depending on how CPU operation mode is set by MOD0 and MOD1 pins. The operation mode used for rewriting the internal flash memory is described separately in Section 6.6, "Programming the Internal Flash Memory."

**Table 3.2.1 Operation Mode Settings**

MOD0	MOD1	MOD2 (Note 1)	Operation mode (Note 2)
VSS	VSS	VSS	Single-chip mode
VSS	VCCE	VSS	External extension mode
VCCE	VSS	VSS	Processor mode (FP = VSS)
VCCE	VCCE	VSS	(Settings inhibited)
–	–	VCCE	(Settings inhibited)

Note 1: Connect VCCE and VSS to the VCCE input power supply and ground, respectively.

Note 2: For the operation mode used to rewrite the internal flash memory (FP = VCCE) which is not shown in the above table, see Section 6.6, "Programming the Internal Flash Memory."

The internal ROM and external extension areas are located differently depending on how operation mode is set. (All other areas in the address space are located the same way.) The following diagram shows how the internal ROM and external extension areas are mapped into the address space in each operation mode. (For flash rewrite mode, see Section 6.6, "Programming the Internal Flash Memory.")

Logical address		Single chip mode	Logical address	External extension mode	Processor mode
2 Gbytes	User space	(64 Mbytes)	Internal ROM area (1 Mbyte)	Internal ROM area (1 Mbyte)	CS0 area (8 Mbytes)
		(64 Mbytes)		CS0 area (7 Mbytes)	
		•	SFR area (16 Kbytes)	SFR area (16 Kbytes)	SFR area (16 Kbytes)
		•	Internal RAM area (176 Kbytes)	Internal RAM area (176 Kbytes)	Internal RAM area (176 Kbytes)
		•			
		•			
		•			
		•			
		•			
		•			
		•			
		•	(64 Mbytes)		
2 Gbytes	System space				
				CS1 area (8 Mbytes)	CS1 area (8 Mbytes)
				CS2 area (8 Mbytes)	CS2 area (8 Mbytes)
				CS3 area (8 Mbytes)	CS3 area (8 Mbytes)
H'E000 0000	NBD control				
H'FFFF FFFF					

Notes: • CS0–CS3 areas: External extension areas of up to 32 Mbytes  
 • : Indicates Ghost area. This area must not be used during programming intentionally.

Figure 3.2.1 Address Space of the M32192F8

Logical address			Single chip mode	Logical address	External extension mode	Processor mode																
2 Gbytes	User space	(64 Mbytes)	Internal ROM area (512 Kbytes)	H'0000 0000 H'0007 FFFF H'0008 0000 H'000F FFFF H'0010 0000	Internal ROM area (512 Kbytes)	CS0 area (8 Mbytes)																
		(64 Mbytes)	SFR area (16 Kbytes)	H'007F FFFF H'0080 0000 H'0080 3FFF	Reserved area (512 Kbytes)																	
		▪		Internal RAM area (32 Kbytes)	H'0080 4000 H'0080 BFFF	CS0 area (7 Mbytes)	SFR area (16 Kbytes)															
		▪	Ghost area in 64-Mbyte units		H'0080 C000	Internal RAM area (32 Kbytes)		Internal RAM area (32 Kbytes)														
		▪		▪	H'00FF FFFF H'0100 0000	CS1 area (8 Mbytes)	CS1 area (8 Mbytes)															
		▪	▪		H'017F FFFF H'0180 0000			CS2 area (8 Mbytes)	CS2 area (8 Mbytes)													
		(64 Mbytes)		▪	H'01FF FFFF H'0200 0000	CS3 area (8 Mbytes)	CS3 area (8 Mbytes)															
		2 Gbytes	System space		NBD control			Internal ROM area (512 Kbytes)	H'027F FFFF H'0280 0000	CS0 area (8 Mbytes)	CS0 area (8 Mbytes)											
				H'7FFF FFFF H'8000 0000		SFR area (16 Kbytes)	H'02FF FFFF H'0300 0000		CS1 area (8 Mbytes)			CS1 area (8 Mbytes)										
							H'E000 0000						Internal RAM area (32 Kbytes)	H'037F FFFF H'0380 0000	CS2 area (8 Mbytes)	CS2 area (8 Mbytes)						
														H'FFFF FFFF			Ghost area in 64-Mbyte units	H'03FF FFFF	CS3 area (8 Mbytes)	CS3 area (8 Mbytes)		
																		H'0000 0000			SFR area (16 Kbytes)	Internal RAM area (32 Kbytes)
H'0007 FFFF	Reserved area (512 Kbytes)																					
		H'0008 0000	CS0 area (7 Mbytes)		SFR area (16 Kbytes)			Internal RAM area (32 Kbytes)														
				H'000F FFFF		Internal RAM area (32 Kbytes)			CS2 area (8 Mbytes)	CS2 area (8 Mbytes)												
							H'0010 0000				Ghost area in 64-Mbyte units	CS3 area (8 Mbytes)	CS3 area (8 Mbytes)									
														H'007F FFFF	CS0 area (8 Mbytes)	CS0 area (8 Mbytes)						
																	H'0080 0000	CS1 area (8 Mbytes)	CS1 area (8 Mbytes)			
H'0080 3FFF	CS2 area (8 Mbytes)																			CS2 area (8 Mbytes)		
		H'0080 4000	CS3 area (8 Mbytes)		CS3 area (8 Mbytes)																	
				H'0080 BFFF		CS0 area (8 Mbytes)		CS0 area (8 Mbytes)														
							H'0080 C000		CS1 area (8 Mbytes)	CS1 area (8 Mbytes)												
											H'00FF FFFF	CS2 area (8 Mbytes)	CS2 area (8 Mbytes)									
														H'0100 0000	CS3 area (8 Mbytes)	CS3 area (8 Mbytes)						
H'017F FFFF	CS0 area (8 Mbytes)																CS0 area (8 Mbytes)					
		H'0180 0000	CS1 area (8 Mbytes)		CS1 area (8 Mbytes)																	
				H'01FF FFFF		CS2 area (8 Mbytes)		CS2 area (8 Mbytes)														
							H'0200 0000		CS3 area (8 Mbytes)	CS3 area (8 Mbytes)												
											H'027F FFFF	CS0 area (8 Mbytes)	CS0 area (8 Mbytes)									
														H'0280 0000	CS1 area (8 Mbytes)	CS1 area (8 Mbytes)						
H'02FF FFFF	CS2 area (8 Mbytes)																CS2 area (8 Mbytes)					
		H'0300 0000	CS3 area (8 Mbytes)		CS3 area (8 Mbytes)																	
				H'037F FFFF		CS0 area (8 Mbytes)		CS0 area (8 Mbytes)														
							H'0380 0000		CS1 area (8 Mbytes)	CS1 area (8 Mbytes)												
											H'03FF FFFF	CS2 area (8 Mbytes)	CS2 area (8 Mbytes)									
														H'0000 0000	CS3 area (8 Mbytes)	CS3 area (8 Mbytes)						
H'0007 FFFF	CS0 area (8 Mbytes)																CS0 area (8 Mbytes)					
		H'0008 0000	CS1 area (8 Mbytes)		CS1 area (8 Mbytes)																	
				H'000F FFFF		CS2 area (8 Mbytes)		CS2 area (8 Mbytes)														
							H'0010 0000		CS3 area (8 Mbytes)	CS3 area (8 Mbytes)												
											H'007F FFFF	CS0 area (8 Mbytes)	CS0 area (8 Mbytes)									
														H'0080 0000	CS1 area (8 Mbytes)	CS1 area (8 Mbytes)						
H'0080 3FFF	CS2 area (8 Mbytes)																CS2 area (8 Mbytes)					
		H'0080 4000	CS3 area (8 Mbytes)		CS3 area (8 Mbytes)																	
				H'0080 BFFF		CS0 area (8 Mbytes)		CS0 area (8 Mbytes)														
							H'0080 C000		CS1 area (8 Mbytes)	CS1 area (8 Mbytes)												
											H'00FF FFFF	CS2 area (8 Mbytes)	CS2 area (8 Mbytes)									
														H'0100 0000	CS3 area (8 Mbytes)	CS3 area (8 Mbytes)						
H'017F FFFF	CS0 area (8 Mbytes)																CS0 area (8 Mbytes)					
		H'0180 0000	CS1 area (8 Mbytes)		CS1 area (8 Mbytes)																	
				H'01FF FFFF		CS2 area (8 Mbytes)		CS2 area (8 Mbytes)														
							H'0200 0000		CS3 area (8 Mbytes)	CS3 area (8 Mbytes)												
											H'027F FFFF	CS0 area (8 Mbytes)	CS0 area (8 Mbytes)									
														H'0280 0000	CS1 area (8 Mbytes)	CS1 area (8 Mbytes)						
H'02FF FFFF	CS2 area (8 Mbytes)																CS2 area (8 Mbytes)					
		H'0300 0000	CS3 area (8 Mbytes)		CS3 area (8 Mbytes)																	
				H'037F FFFF		CS0 area (8 Mbytes)		CS0 area (8 Mbytes)														
							H'0380 0000		CS1 area (8 Mbytes)	CS1 area (8 Mbytes)												
											H'03FF FFFF	CS2 area (8 Mbytes)	CS2 area (8 Mbytes)									


Notes: • CS0–CS3 areas: External extension areas of up to 32 Mbytes  
 •  : Indicates Ghost area. This area must not be used during programming intentionally.

Figure 3.2.2 Address Space of the M32195F4

Logical address			Single chip mode	Logical address	External extension mode	Processor mode
2 Gbytes	User space	(64 Mbytes)	Internal ROM area (1 Mbyte)	H'0000 0000	Internal ROM area (1 Mbyte)	CS0 area (8 Mbytes)
		(64 Mbytes)	X	H'000F FFFF H'0010 0000	CS0 area (7 Mbytes)	
		•	SFR area (16 Kbytes)	H'007F FFFF H'0080 0000	SFR area (16 Kbytes)	SFR area (16 Kbytes)
		•	Internal RAM area (64 Kbytes)	H'0080 3FFF H'0080 4000	Internal RAM area (64 Kbytes)	Internal RAM area (64 Kbytes)
		•	X	H'0081 3FFF H'0081 4000	X	X
		•	X	H'00FF FFFF H'0100 0000	CS1 area (8 Mbytes)	CS1 area (8 Mbytes)
		•	X	H'017F FFFF H'0180 0000	X	X
		•	X	H'01FF FFFF H'0200 0000	CS2 area (8 Mbytes)	CS2 area (8 Mbytes)
		•	X	H'027F FFFF H'0280 0000	X	X
		•	X	H'02FF FFFF H'0300 0000	CS3 area (8 Mbytes)	CS3 area (8 Mbytes)
2 Gbytes	System space	X	X	H'037F FFFF H'0380 0000	X	X
		X	X	H'03FF FFFF	X	X
H'7FFF FFFF						
H'8000 0000						
2 Gbytes	System space					
H'E000 0000	NBD control					
H'FFFF FFFF						


Notes: • CS0–CS3 areas: External extension areas of up to 32 Mbytes  
 •  : Indicates Ghost area. This area must not be used during programming intentionally.

Figure 3.2.3 Address Space of the M32196F8



### 3.3 Internal ROM and External Extension Areas

The 64-Mbyte area in the user space from the address H'0000 0000 to the address H'03FF FFFF comprise the internal ROM and external extension areas. For the address mapping of these areas that differs with each operation mode, see Section 3.2, "Operation Modes."

#### 3.3.1 Internal ROM Area

The internal ROM is allocated to the addresses shown below. Located at the beginning of this area is the EIT vector entry (and the ICU vector table).

**Table 3.3.1 Internal ROM Allocation Address**

Type Name	Size	Allocation Address
M32192F8, M32196F8	1 Mbytes	H'0000 0000 to H'000F FFFF
M32195F4	512 Kbytes	H'0000 0000 to H'0007 FFFF

#### 3.3.2 External Extension Area

The external extension area is only available when external extension or processor mode is selected by operation mode settings. When accessing the external extension area, the control signals necessary to access external devices are output.

The CS0# through CS3# signals are output corresponding to the address mapping of the external extension area. The CS0#, CS1#, CS2# and CS3# signals are output for the CS0, CS1, CS2 and CS3 areas, respectively.

**Table 3.3.2 Address Mapping of the External Extension Area in Each Operation Mode**

Operation Mode	Address Mapping of External Extension Area
Single-chip mode	None
External extension mode	Addresses H'0010 0000 to H'007F FFFF (CS0 area: 7 Mbytes) Addresses H'0100 0000 to H'017F FFFF (CS1 area: 8 Mbytes) Addresses H'0200 0000 to H'027F FFFF (CS2 area: 8 Mbytes) Addresses H'0300 0000 to H'037F FFFF (CS3 area: 8 Mbytes)
Processor mode	Addresses H'0000 0000 to H'007F FFFF (CS0 area: 8 Mbytes) Addresses H'0100 0000 to H'017F FFFF (CS1 area: 8 Mbytes) Addresses H'0200 0000 to H'027F FFFF (CS2 area: 8 Mbytes) Addresses H'0300 0000 to H'037F FFFF (CS3 area: 8 Mbytes)

### 3.4 Internal RAM and SFR Areas

The 8-Mbyte area from the address H'0080 0000 to the address H'00FF FFFF comprise the internal RAM and SFR (Special Function Register) areas. Of these, the space that the user can actually use is a 256-Kbyte area from the address H'0080 0000 to the address H'0083 FFFF. The other areas here are ghosts in 256-Kbyte units. (Do not use the ghost area intentionally during programming.)

#### 3.4.1 Internal RAM Area

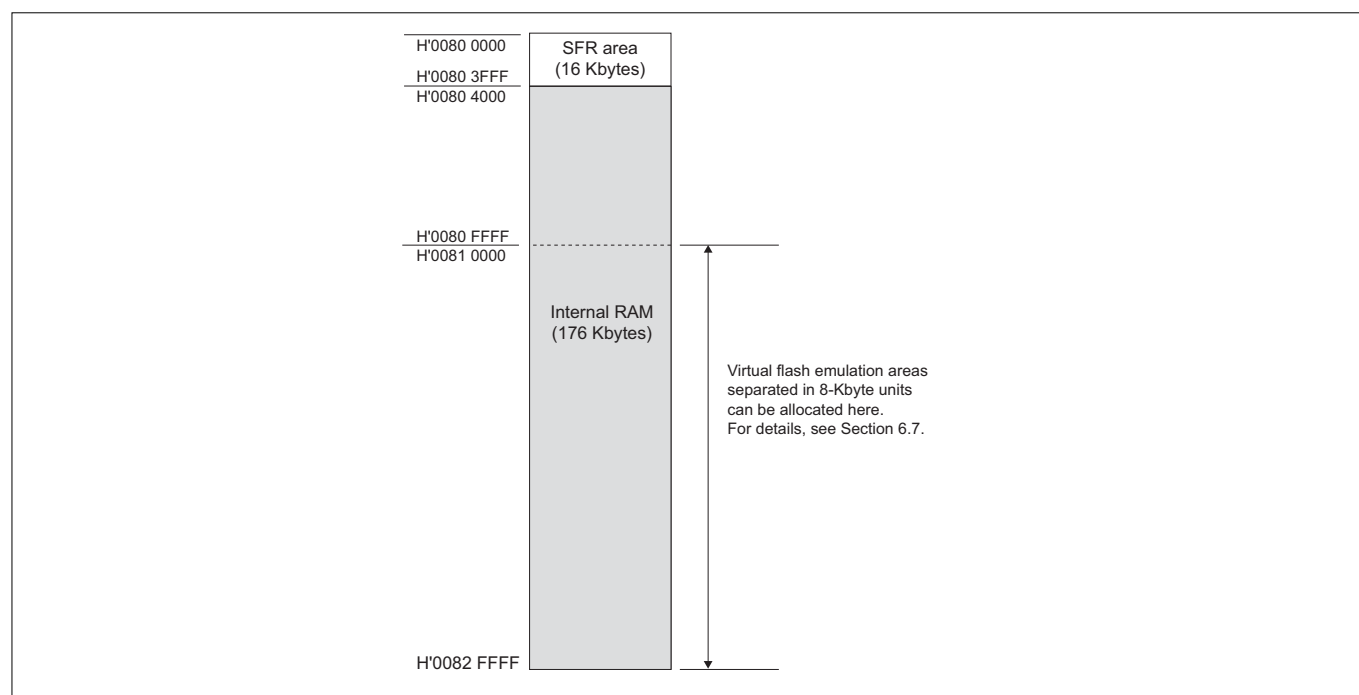
The internal RAM area is allocated to the addresses shown below.

**Table 3.4.1 Internal RAM Allocation Address**

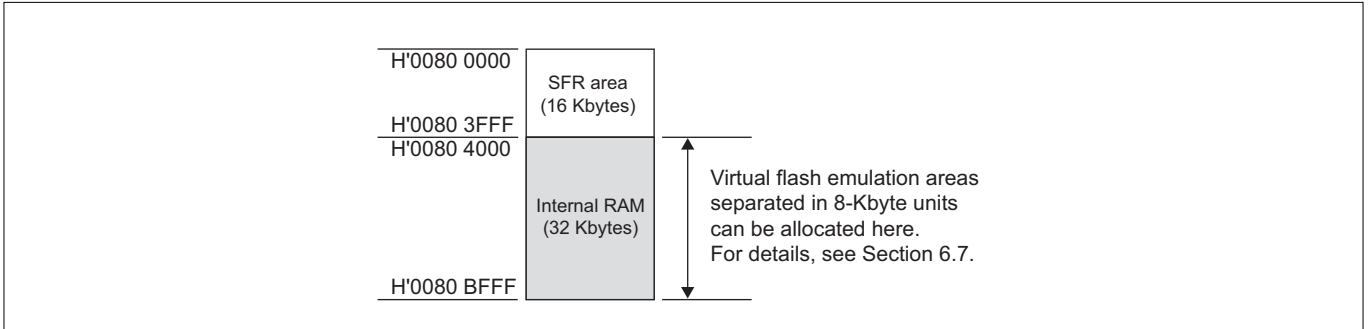
Type Name	Size	Allocation Address
M32192F8	176 Kbytes	H'0080 4000 to H'0082 FFFF
M32195F4	32 Kbytes	H'0080 4000 to H'0080 BFFF
M32196F8	64 Kbytes	H'0080 4000 to H'0081 3FFF

#### 3.4.2 SFR (Special Function Register) Area

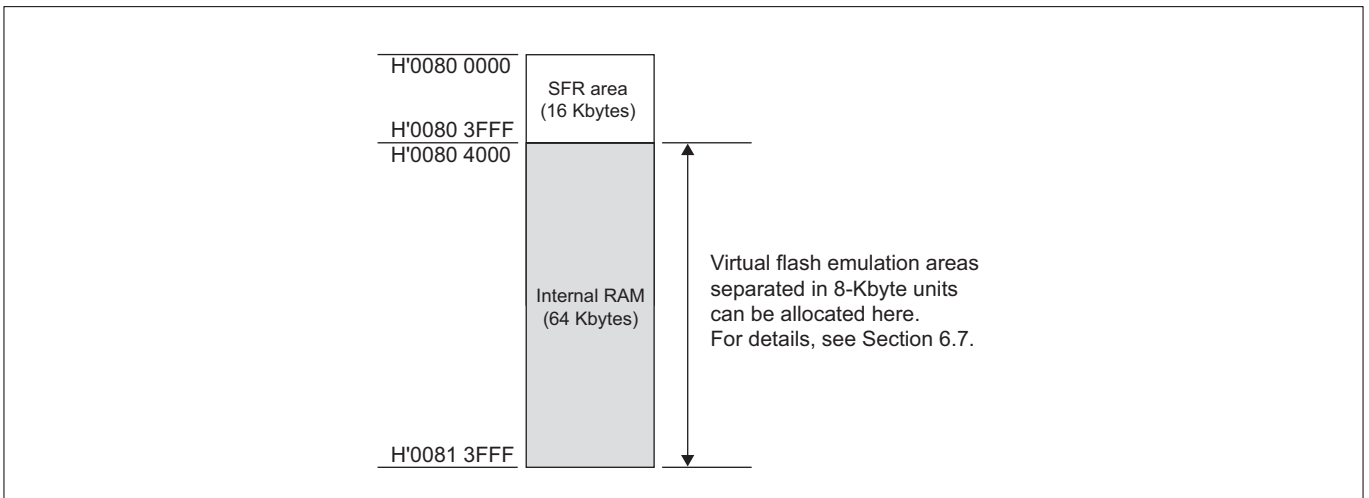
The addresses H'0080 0000 to H'0080 3FFFF comprise the SFR (Special Function Register) area. Located in this area are the internal peripheral I/O registers.



**Figure 3.4.1 Internal RAM and SFR (Special Function Register) Areas of the M32192F8**



**Figure 3.4.2 Internal RAM and SFR (Special Function Register) Areas of the M32195F4**



**Figure 3.4.3 Internal RAM and SFR (Special Function Register) Areas of the M32196F8**

## SFR Area Register Map (1/37)

Address	+0 address		+1 address		See pages
	b0	b7	b8	b15	
H'0080 0000	Interrupt Vector Register (IVECT)				5-5
H'0080 0002	(Use inhibited area)				
H'0080 0004	Interrupt Request Mask Register (IMASK)		(Use inhibited area)		5-6
H'0080 0006	SBI Control Register (SBICR)		(Use inhibited area)		5-7
	(Use inhibited area)				
H'0080 0056	RAM Write Monitor Interrupt Control Register (IRAMWRCR)		CAN1 Error Interrupt Control Register (ICAN1ERCR)		5-8
H'0080 0058	CAN1 Single-Shot Interrupt Control Register (ICAN1SSCR)		CAN1 Transmit/Receive Interrupt Control Register (ICAN1TRCR)		5-8
H'0080 005A	CAN0 Error Interrupt Control Register (ICAN0ERCR)		CAN0 Single-Shot Interrupt Control Register (ICAN0SSCR)		5-8
H'0080 005C	CAN0 Transmit/Receive Interrupt Control Register (ICAN0TRCR)		DRI Event Detection Interrupt Control Register (IDRIEVCr)		5-8
H'0080 005E	DRI Counter Interrupt Control Register (IDRICNTR)		DRI Transfer Interrupt Control Register (IDRITRCR)		5-8
H'0080 0060	CAN0 Transmit/Receive & Error Interrupt Control Register (ICAN0CR)		TML1 Input Interrupt Control Register (ITML1CR)		5-8
H'0080 0062	(Use inhibited area)				
H'0080 0064	SIO4,5 Transmit/Receive Interrupt Control Register (ISIO45CR)		TOU1 Output Interrupt Control Register (ITOU1CR)		5-8
H'0080 0066	TID1 Output Interrupt Control Register (ITID1CR)		RTD Interrupt Control Register (IRTDCR)		5-8
H'0080 0068	SIO2,3 Transmit/Receive Interrupt Control Register (ISIO23CR)		DMA5–9 Interrupt Control Register (IDMA59CR)		5-8
H'0080 006A	TOU0 Output Interrupt Control Register (ITOU0CR)		TID0 Output Interrupt Control Register (ITID0CR)		5-8
H'0080 006C	A/D0 Conversion Interrupt Control Register (IAD0CCR)		SIO0 Transmit Interrupt Control Register (ISIO0TXCR)		5-8
H'0080 006E	SIO0 Receive Interrupt Control Register (ISIO0RXCR)		SIO1 Transmit Interrupt Control Register (ISIO1TXCR)		5-8
H'0080 0070	SIO1 Receive Interrupt Control Register (ISIO1RXCR)		DMA0–4 Interrupt Control Register (IDMA04CR)		5-8
H'0080 0072	MJT Output Interrupt Control Register 0 (IMJTOCR0)		MJT Output Interrupt Control Register 1 (IMJTOCR1)		5-8
H'0080 0074	MJT Output Interrupt Control Register 2 (IMJTOCR2)		MJT Output Interrupt Control Register 3 (IMJTOCR3)		5-8
H'0080 0076	MJT Output Interrupt Control Register 4 (IMJTOCR4)		MJT Output Interrupt Control Register 5 (IMJTOCR5)		5-8
H'0080 0078	MJT Output Interrupt Control Register 6 (IMJTOCR6)		MJT Output Interrupt Control Register 7 (IMJTOCR7)		5-8
H'0080 007A	MJT Input Interrupt Control Register 0 (IMJTICR0)		MJT Input Interrupt Control Register 1 (IMJTICR1)		5-8
H'0080 007C	MJT Input Interrupt Control Register 2 (IMJTICR2)		MJT Input Interrupt Control Register 3 (IMJTICR3)		5-8
H'0080 007E	MJT Input Interrupt Control Register 4 (IMJTICR4)		CAN1 Transmit/Receive & Error Interrupt Control Register (ICAN1CR)		5-8
H'0080 0080	A/D0 Single Mode Register 0 (AD0SIM0)		A/D0 Single Mode Register 1 (AD0SIM1)		11-17 11-19
H'0080 0082	(Use inhibited area)		A/D0 Single Mode Register 2 (AD0SIM2)		11-21
H'0080 0084	A/D0 Scan Mode Register 0 (AD0SCM0)		A/D0 Scan Mode Register 1 (AD0SCM1)		11-22 11-24
H'0080 0086	A/D0 Disconnection Detection Assist Function Control Register (AD0DDACR)		A/D0 Conversion Speed Control Register (AD0CVSCR)		11-27 11-26
H'0080 0088	A/D0 Successive Approximation Register (AD0SAR)				11-31
H'0080 008A	A/D0 Disconnection Detection Assist Method Select Register (AD0DDASEL)				11-28
H'0080 008C	A/D0 Compare Data Register (AD0CMP)				11-32
H'0080 008E	(Use inhibited area)				

SFR Area Register Map (2/37)

Address	+0 address		+1 address		See pages
	b0	b7	b8	b15	
H'0080 0090	10-bit A/D0 Data Register 0 (AD0DT0)				11-33
H'0080 0092	10-bit A/D0 Data Register 1 (AD0DT1)				11-33
H'0080 0094	10-bit A/D0 Data Register 2 (AD0DT2)				11-33
H'0080 0096	10-bit A/D0 Data Register 3 (AD0DT3)				11-33
H'0080 0098	10-bit A/D0 Data Register 4 (AD0DT4)				11-33
H'0080 009A	10-bit A/D0 Data Register 5 (AD0DT5)				11-33
H'0080 009C	10-bit A/D0 Data Register 6 (AD0DT6)				11-33
H'0080 009E	10-bit A/D0 Data Register 7 (AD0DT7)				11-33
H'0080 00A0	10-bit A/D0 Data Register 8 (AD0DT8)				11-33
H'0080 00A2	10-bit A/D0 Data Register 9 (AD0DT9)				11-33
H'0080 00A4	10-bit A/D0 Data Register 10 (AD0DT10)				11-33
H'0080 00A6	10-bit A/D0 Data Register 11 (AD0DT11)				11-33
H'0080 00A8	10-bit A/D0 Data Register 12 (AD0DT12)				11-33
H'0080 00AA	10-bit A/D0 Data Register 13 (AD0DT13)				11-33
H'0080 00AC	10-bit A/D0 Data Register 14 (AD0DT14)				11-33
H'0080 00AE	10-bit A/D0 Data Register 15 (AD0DT15)				11-33
	(Use inhibited area)				
H'0080 00D0	(Use inhibited area)		8-bit A/D0 Data Register 0 (AD08DT0)		11-34
H'0080 00D2	(Use inhibited area)		8-bit A/D0 Data Register 1 (AD08DT1)		11-34
H'0080 00D4	(Use inhibited area)		8-bit A/D0 Data Register 2 (AD08DT2)		11-34
H'0080 00D6	(Use inhibited area)		8-bit A/D0 Data Register 3 (AD08DT3)		11-34
H'0080 00D8	(Use inhibited area)		8-bit A/D0 Data Register 4 (AD08DT4)		11-34
H'0080 00DA	(Use inhibited area)		8-bit A/D0 Data Register 5 (AD08DT5)		11-34
H'0080 00DC	(Use inhibited area)		8-bit A/D0 Data Register 6 (AD08DT6)		11-34
H'0080 00DE	(Use inhibited area)		8-bit A/D0 Data Register 7 (AD08DT7)		11-34
H'0080 00E0	(Use inhibited area)		8-bit A/D0 Data Register 8 (AD08DT8)		11-34
H'0080 00E2	(Use inhibited area)		8-bit A/D0 Data Register 9 (AD08DT9)		11-34
H'0080 00E4	(Use inhibited area)		8-bit A/D0 Data Register 10 (AD08DT10)		11-34
H'0080 00E6	(Use inhibited area)		8-bit A/D0 Data Register 11 (AD08DT11)		11-34
H'0080 00E8	(Use inhibited area)		8-bit A/D0 Data Register 12 (AD08DT12)		11-34
H'0080 00EA	(Use inhibited area)		8-bit A/D0 Data Register 13 (AD08DT13)		11-34
H'0080 00EC	(Use inhibited area)		8-bit A/D0 Data Register 14 (AD08DT14)		11-34
H'0080 00EE	(Use inhibited area)		8-bit A/D0 Data Register 15 (AD08DT15)		11-34
	(Use inhibited area)				

SFR Area Register Map (3/37)

Address	+0 address		+1 address		See pages
	b0	b7	b8	b15	
H'0080 0100	SIO23 Interrupt Request Status Register (SI23STAT)		SIO03 Interrupt Request Mask Register (SI03MASK)		12-9 12-10
H'0080 0102	SIO03 Interrupt Request Source Select Register (SI03SEL)		(Use inhibited area)		12-11
	(Use inhibited area)				
H'0080 0110	SIO0 Transmit Control Register (S0TCNT)		SIO0 Transmit/Receive Mode Register (S0MOD)		12-14 12-15
H'0080 0112	SIO0 Transmit Buffer Register (S0TXB)				12-19
H'0080 0114	SIO0 Receive Buffer Register (S0RXB)				12-20
H'0080 0116	SIO0 Receive Control Register (S0RCNT)		SIO0 Baud Rate Register (S0BAUR)		12-21 12-24
H'0080 0118	SIO0 Special Mode Register (S0SMOD)		(Use inhibited area)		12-27
	(Use inhibited area)				
H'0080 0120	SIO1 Transmit Control Register (S1TCNT)		SIO1 Transmit/Receive Mode Register (S1MOD)		12-14 12-15
H'0080 0122	SIO1 Transmit Buffer Register (S1TXB)				12-19
H'0080 0124	SIO1 Receive Buffer Register (S1RXB)				12-20
H'0080 0126	SIO1 Receive Control Register (S1RCNT)		SIO1 Baud Rate Register (S1BAUR)		12-21 12-24
H'0080 0128	SIO1 Special Mode Register (S1SMOD)		(Use inhibited area)		12-27
	(Use inhibited area)				
H'0080 0130	SIO2 Transmit Control Register (S2TCNT)		SIO2 Transmit/Receive Mode Register (S2MOD)		12-14 12-15
H'0080 0132	SIO2 Transmit Buffer Register (S2TXB)				12-19
H'0080 0134	SIO2 Receive Buffer Register (S2RXB)				12-20
H'0080 0136	SIO2 Receive Control Register (S2RCNT)		SIO2 Baud Rate Register (S2BAUR)		12-21 12-24
H'0080 0138	SIO2 Special Mode Register (S2SMOD)		(Use inhibited area)		12-27
	(Use inhibited area)				
H'0080 0140	SIO3 Transmit Control Register (S3TCNT)		SIO3 Transmit/Receive Mode Register (S3MOD)		12-14 12-15
H'0080 0142	SIO3 Transmit Buffer Register (S3TXB)				12-19
H'0080 0144	SIO3 Receive Buffer Register (S3RXB)				12-20
H'0080 0146	SIO3 Receive Control Register (S3RCNT)		SIO3 Baud Rate Register (S3BAUR)		12-21 12-24
H'0080 0148	SIO3 Special Mode Register (S3SMOD)		(Use inhibited area)		12-27
	(Use inhibited area)				
H'0080 0180	CS0 Area Wait Control Register (CS0WTCR)		CS1 Area Wait Control Register (CS1WTCR)		18-4
H'0080 0182	CS2 Area Wait Control Register (CS2WTCR)		CS3 Area Wait Control Register (CS3WTCR)		18-4
	(Use inhibited area)				
H'0080 01A0	CLKOUT Select Register (CLKOUTSEL)		(Use inhibited area)		17-16 20-8
H'0080 01A2	Flash E/W Wait Select Register (FWAIT)		(Use inhibited area)		18-6
	(Use inhibited area)				
H'0080 01E0	Flash Mode Register (FMOD)		Flash Status Register (FSTAT)		6-15 6-16

SFR Area Register Map (4/37)

Address	+0 address b0	b7	+1 address b8	b15	See pages
H'0080 01E2	Flash Control Register 1 (FCNT1)		Flash Control Register 2 (FCNT2)		6-17 6-18
H'0080 01E4	Flash Control Register 3 (FCNT3)		Flash Control Register 4 (FCNT4)		6-19 6-22
	(Use inhibited area)				
H'0080 0200	Common Count Clock Select Register (CNTCKSEL)		Clock Bus & Input Event Bus Control Register (CKIEBCR)		10-12 10-17
H'0080 0202	Prescaler Register 0 (PRS0)		Prescaler Register 1 (PRS1)		10-13
H'0080 0204	Prescaler Register 2 (PRS2)		Output Event Bus Control Register (OEBCR)		10-13 10-18
	(Use inhibited area)				
H'0080 0210	TCLK Input Processing Control Register (TCLKCR)				10-21
H'0080 0212	TIN Input Processing Control Register 0 (TINCR0)				10-22
H'0080 0214	TIN Input Processing Control Register 1 (TINCR1)				10-23
H'0080 0216	TIN Input Processing Control Register 2 (TINCR2)				10-24
H'0080 0218	TIN Input Processing Control Register 3 (TINCR3)				10-25
H'0080 021A	TIN Input Processing Control Register 4 (TINCR4)				10-25
	(Use inhibited area)				
H'0080 0220	F/F Source Select Register 0 (FFS0)				10-28
H'0080 0222	(Use inhibited area)		F/F Source Select Register 1 (FFS1)		10-29
H'0080 0224	F/F Protect Register 0 (FFP0)				10-30
H'0080 0226	F/F Data Register 0 (FFD0)				10-32
H'0080 0228	(Use inhibited area)		F/F Protect Register 1 (FFP1)		10-30
H'0080 022A	(Use inhibited area)		F/F Data Register 1 (FFD1)		10-32
	(Use inhibited area)				
H'0080 0230	TOP Interrupt Control Register 0 (TOPIR0)		TOP Interrupt Control Register 1 (TOPIR1)		10-38
H'0080 0232	TOP Interrupt Control Register 2 (TOPIR2)		TOP Interrupt Control Register 3 (TOPIR3)		10-40 10-41
H'0080 0234	TIO Interrupt Control Register 0 (TIOIR0)		TIO Interrupt Control Register 1 (TIOIR1)		10-42 10-43
H'0080 0236	TIO Interrupt Control Register 2 (TIOIR2)		TMS Interrupt Control Register (TMSIR)		10-44 10-45
H'0080 0238	TIN Interrupt Control Register 0 (TINIR0)		TIN Interrupt Control Register 1 (TINIR1)		10-46 10-47
H'0080 023A	TIN Interrupt Control Register 2 (TINIR2)		TIN Interrupt Control Register 3 (TINIR3)		10-48
H'0080 023C	TIN Interrupt Control Register 4 (TINIR4)		TIN Interrupt Control Register 5 (TINIR5)		10-50
H'0080 023E	TIN Interrupt Control Register 6 (TINIR6)		TIN Interrupt Control Register 7 (TINIR7)		10-52 10-55
H'0080 0240	TOP0 Counter (TOP0CT)				10-71
H'0080 0242	TOP0 Reload Register (TOP0RL)				10-72
H'0080 0244	(Use inhibited area)				
H'0080 0246	TOP0 Correction Register (TOP0CC)				10-73
	(Use inhibited area)				

SFR Area Register Map (5/37)

Address	+0 address		+1 address		See pages
	b0	b7	b8	b15	
H'0080 0250	TOP1 Counter (TOP1CT)				10-71
H'0080 0252	TOP1 Reload Register (TOP1RL)				10-72
H'0080 0254	(Use inhibited area)				
H'0080 0256	TOP1 Correction Register (TOP1CC)				10-73
	(Use inhibited area)				
H'0080 0260	TOP2 Counter (TOP2CT)				10-71
H'0080 0262	TOP2 Reload Register (TOP2RL)				10-72
H'0080 0264	(Use inhibited area)				
H'0080 0266	TOP2 Correction Register (TOP2CC)				10-73
	(Use inhibited area)				
H'0080 0270	TOP3 Counter (TOP3CT)				10-71
H'0080 0272	TOP3 Reload Register (TOP3RL)				10-72
H'0080 0274	(Use inhibited area)				
H'0080 0276	TOP3 Correction Register (TOP3CC)				10-73
	(Use inhibited area)				
H'0080 0280	TOP4 Counter (TOP4CT)				10-71
H'0080 0282	TOP4 Reload Register (TOP4RL)				10-72
H'0080 0284	(Use inhibited area)				
H'0080 0286	TOP4 Correction Register (TOP4CC)				10-73
	(Use inhibited area)				
H'0080 0290	TOP5 Counter (TOP5CT)				10-71
H'0080 0292	TOP5 Reload Register (TOP5RL)				10-72
H'0080 0294	(Use inhibited area)				
H'0080 0296	TOP5 Correction Register (TOP5CC)				10-73
H'0080 0298	(Use inhibited area)				
H'0080 029A	TOP0–5 Control Register 0 (TOP05CR0)				10-67
H'0080 029C	(Use inhibited area)		TOP0–5 Control Register 1 (TOP05CR1)		10-67
	(Use inhibited area)				
H'0080 02A0	TOP6 Counter (TOP6CT)				10-71
H'0080 02A2	TOP6 Reload Register (TOP6RL)				10-72
H'0080 02A4	(Use inhibited area)				
H'0080 02A6	TOP6 Correction Register (TOP6CC)				10-73
H'0080 02A8	(Use inhibited area)				
H'0080 02AA	TOP6,7 Control Register (TOP67CR)				10-69



SFR Area Register Map (6/37)

Address	+0 address		+1 address		See pages
	b0	b7   b8	b7   b8	b15	
		(Use inhibited area)			
H'0080 02B0		TOP7 Counter (TOP7CT)			10-71
H'0080 02B2		TOP7 Reload Register (TOP7RL)			10-72
H'0080 02B4		(Use inhibited area)			
H'0080 02B6		TOP7 Correction Register (TOP7CC)			10-73
		(Use inhibited area)			
H'0080 02C0		TOP8 Counter (TOP8CT)			10-71
H'0080 02C2		TOP8 Reload Register (TOP8RL)			10-72
H'0080 02C4		(Use inhibited area)			
H'0080 02C6		TOP8 Correction Register (TOP8CC)			10-73
		(Use inhibited area)			
H'0080 02D0		TOP9 Counter (TOP9CT)			10-71
H'0080 02D2		TOP9 Reload Register (TOP9RL)			10-72
H'0080 02D4		(Use inhibited area)			
H'0080 02D6		TOP9 Correction Register (TOP9CC)			10-73
		(Use inhibited area)			
H'0080 02E0		TOP10 Counter (TOP10CT)			10-71
H'0080 02E2		TOP10 Reload Register (TOP10RL)			10-72
H'0080 02E4		(Use inhibited area)			
H'0080 02E6		TOP10 Correction Register (TOP10CC)			10-73
H'0080 02E8		(Use inhibited area)			
H'0080 02EA		TOP8-10 Control Register (TOP810CR)			10-70
		(Use inhibited area)			
H'0080 02FA		TOP0-10 External Enable Permit Register (TOPEEN)			10-74
H'0080 02FC		TOP0-10 Enable Protect Register (TOPPRO)			10-74
H'0080 02FE		TOP0-10 Count Enable Register (TOPCEN)			10-75
H'0080 0300		TIO0 Counter (TIO0CT)			10-105
H'0080 0302		(Use inhibited area)			
H'0080 0304		TIO0 Reload 1 Register (TIO0RL1)			10-107
H'0080 0306		TIO0 Reload 0/ Measure Register (TIO0RL0)			10-106
		(Use inhibited area)			
H'0080 0310		TIO1 Counter (TIO1CT)			10-105
H'0080 0312		(Use inhibited area)			
H'0080 0314		TIO1 Reload 1 Register (TIO1RL1)			10-107

SFR Area Register Map (7/37)

Address	+0 address		+1 address		See pages
	b0	b7	b8	b15	
H'0080 0316	TIO1 Reload 0/ Measure Register (TIO1RL0)				10-106
H'0080 0318	(Use inhibited area)				
H'0080 031A	TIO0-3 Control Register 0 (TIO03CR0)				10-98
H'0080 031C	(Use inhibited area)		TIO0-3 Control Register 1 (TIO03CR1)		10-99
	(Use inhibited area)				
H'0080 0320	TIO2 Counter (TIO2CT)				10-105
H'0080 0322	(Use inhibited area)				
H'0080 0324	TIO2 Reload 1 Register (TIO2RL1)				10-107
H'0080 0326	TIO2 Reload 0/ Measure Register (TIO2RL0)				10-106
	(Use inhibited area)				
H'0080 0330	TIO3 Counter (TIO3CT)				10-105
H'0080 0332	(Use inhibited area)				
H'0080 0334	TIO3 Reload 1 Register (TIO3RL1)				10-107
H'0080 0336	TIO3 Reload 0/ Measure Register (TIO3RL0)				10-106
	(Use inhibited area)				
H'0080 0340	TIO4 Counter (TIO4CT)				10-105
H'0080 0342	(Use inhibited area)				
H'0080 0344	TIO4 Reload 1 Register (TIO4RL1)				10-107
H'0080 0346	TIO4 Reload 0/ Measure Register (TIO4RL0)				10-106
H'0080 0348	(Use inhibited area)				
H'0080 034A	TIO4 Control Register (TIO4CR)		TIO5 Control Register (TIO5CR)		10-100 10-102
	(Use inhibited area)				
H'0080 0350	TIO5 Counter (TIO5CT)				10-105
H'0080 0352	(Use inhibited area)				
H'0080 0354	TIO5 Reload 1 Register (TIO5RL1)				10-107
H'0080 0356	TIO5 Reload 0/ Measure Register (TIO5RL0)				10-106
	(Use inhibited area)				
H'0080 0360	TIO6 Counter (TIO6CT)				10-105
H'0080 0362	(Use inhibited area)				
H'0080 0364	TIO6 Reload 1 Register (TIO6RL1)				10-107
H'0080 0366	TIO6 Reload 0/ Measure Register (TIO6RL0)				10-106
H'0080 0368	(Use inhibited area)				
H'0080 036A	TIO6 Control Register (TIO6CR)		TIO7 Control Register (TIO7CR)		10-103 10-104
	(Use inhibited area)				

SFR Area Register Map (8/37)

Address	b0	+0 address	b7	b8	+1 address	b15	See pages
H'0080 0370	TIO7 Counter (TIO7CT)						10-105
H'0080 0372	(Use inhibited area)						
H'0080 0374	TIO7 Reload 1 Register (TIO7RL1)						10-107
H'0080 0376	TIO7 Reload 0/ Measure Register (TIO7RL0)						10-106
	(Use inhibited area)						
H'0080 0380	TIO8 Counter (TIO8CT)						10-105
H'0080 0382	(Use inhibited area)						
H'0080 0384	TIO8 Reload 1 Register (TIO8RL1)						10-107
H'0080 0386	TIO8 Reload 0/ Measure Register (TIO8RL0)						10-106
H'0080 0388	(Use inhibited area)						
H'0080 038A	TIO8 Control Register (TIO8CR)			TIO9 Control Register (TIO9CR)			10-104 10-105
	(Use inhibited area)						
H'0080 0390	TIO9 Counter (TIO9CT)						10-105
H'0080 0392	(Use inhibited area)						
H'0080 0394	TIO9 Reload 1 Register (TIO9RL1)						10-107
H'0080 0396	TIO9 Reload 0/ Measure Register (TIO9RL0)						10-106
	(Use inhibited area)						
H'0080 03BC	TIO0-9 Enable Protect Register (TIOPRO)						10-108
H'0080 03BE	TIO0-9 Count Enable Register (TIOCEN)						10-109
H'0080 03C0	TMS0 Counter (TMSOCT)						10-127
H'0080 03C2	TMS0 Measure 3 Register (TMS0MR3)						10-127
H'0080 03C4	TMS0 Measure 2 Register (TMS0MR2)						10-127
H'0080 03C6	TMS0 Measure 1 Register (TMS0MR1)						10-127
H'0080 03C8	TMS0 Measure 0 Register (TMS0MR0)						10-127
H'0080 03CA	TMS0 Control Register (TMS0CR)			TMS1 Control Register (TMS1CR)			10-126
	(Use inhibited area)						
H'0080 03D0	TMS1 Counter (TMS1CT)						10-127
H'0080 03D2	TMS1 Measure 3 Register (TMS1MR3)						10-127
H'0080 03D4	TMS1 Measure 2 Register (TMS1MR2)						10-127
H'0080 03D6	TMS1 Measure 1 Register (TMS1MR1)						10-127
H'0080 03D8	TMS1 Measure 0 Register (TMS1MR0)						10-127
	(Use inhibited area)						
H'0080 03E0	TML0 Counter (TML0CT)			(Upper) (TML0CTH)			10-132
H'0080 03E2	-----			(Lower) (TML0CTL)			

SFR Area Register Map (9/37)

Address	b0	+0 address	b7	b8	+1 address	b15	See pages
		(Use inhibited area)					
H'0080 03EA		(Use inhibited area)			TML0 Control Register (TML0CR)		10-131
		(Use inhibited area)					
H'0080 03F0		TML0 Measure 3 Register (TML0MR3)			(Upper) (TML0MR3H)		10-132
H'0080 03F2		-----			(Lower) (TML0MR3L)		
H'0080 03F4		TML0 Measure 2 Register (TML0MR2)			(Upper) (TML0MR2H)		10-132
H'0080 03F6		-----			(Lower) (TML0MR2L)		
H'0080 03F8		TML0 Measure 1 Register (TML0MR1)			(Upper) (TML0MR1H)		10-132
H'0080 03FA		-----			(Lower) (TML0MR1L)		
H'0080 03FC		TML0 Measure 0 Register (TML0MR0)			(Upper) (TML0MR0H)		10-132
H'0080 03FE		-----			(Lower) (TML0MR0L)		
H'0080 0400		DMA0–4 Interrupt Request Status Register (DM04ITST)			DMA0–4 Interrupt Request Mask Register (DM04ITMK)		9-35 9-36
		(Use inhibited area)					
H'0080 0408		DMA5–9 Interrupt Request Status Register (DM59ITST)			DMA5–9 Interrupt Request Mask Register (DM59ITMK)		9-35 9-36
		(Use inhibited area)					
H'0080 0410		DMA0 Channel Control Register 0 (DM0CNT0)			DMA0 Channel Control Register 1 (DM0CNT1)		9-6 9-7
H'0080 0412		DMA0 Source Address Register (DM0SA)					9-30
H'0080 0414		DMA0 Destination Address Register (DM0DA)					9-31
H'0080 0416		DMA0 Transfer Count Register (DM0TCT)					9-32
H'0080 0418		DMA5 Channel Control Register 0 (DM5CNT0)			DMA5 Channel Control Register 1 (DM5CNT1)		9-16 9-17
H'0080 041A		DMA5 Source Address Register (DM5SA)					9-30
H'0080 041C		DMA5 Destination Address Register (DM5DA)					9-31
H'0080 041E		DMA5 Transfer Count Register (DM5TCT)					9-32
H'0080 0420		DMA1 Channel Control Register 0 (DM1CNT0)			DMA1 Channel Control Register 1 (DM1CNT1)		9-8 9-9
H'0080 0422		DMA1 Source Address Register (DM1SA)					9-30
H'0080 0424		DMA1 Destination Address Register (DM1DA)					9-31
H'0080 0426		DMA1 Transfer Count Register (DM1TCT)					9-32
H'0080 0428		DMA6 Channel Control Register 0 (DM6CNT0)			DMA6 Channel Control Register 1 (DM6CNT1)		9-18 9-19
H'0080 042A		DMA6 Source Address Register (DM6SA)					9-30
H'0080 042C		DMA6 Destination Address Register (DM6DA)					9-31
H'0080 042E		DMA6 Transfer Count Register (DM6TCT)					9-32
H'0080 0430		DMA2 Channel Control Register 0 (DM2CNT0)			DMA2 Channel Control Register 1 (DM2CNT1)		9-10 9-11
H'0080 0432		DMA2 Source Address Register (DM2SA)					9-30
H'0080 0434		DMA2 Destination Address Register (DM2DA)					9-31

## SFR Area Register Map (10/37)

Address	+0 address		+1 address		See pages
	b0	b7	b8	b15	
H'0080 0436	DMA2 Transfer Count Register (DM2TCT)				9-32
H'0080 0438	DMA7 Channel Control Register 0 (DM7CNT0)		DMA7 Channel Control Register 1 (DM7CNT1)		9-20 9-21
H'0080 043A	DMA7 Source Address Register (DM7SA)				9-30
H'0080 043C	DMA7 Destination Address Register (DM7DA)				9-31
H'0080 043E	DMA7 Transfer Count Register (DM7TCT)				9-32
H'0080 0440	DMA3 Channel Control Register 0 (DM3CNT0)		DMA3 Channel Control Register 1 (DM3CNT1)		9-12 9-13
H'0080 0442	DMA3 Source Address Register (DM3SA)				9-30
H'0080 0444	DMA3 Destination Address Register (DM3DA)				9-31
H'0080 0446	DMA3 Transfer Count Register (DM3TCT)				9-32
H'0080 0448	DMA8 Channel Control Register 0 (DM8CNT0)		DMA8 Channel Control Register 1 (DM8CNT1)		9-22 9-23
H'0080 044A	DMA8 Source Address Register (DM8SA)				9-30
H'0080 044C	DMA8 Destination Address Register (DM8DA)				9-31
H'0080 044E	DMA8 Transfer Count Register (DM8TCT)				9-32
H'0080 0450	DMA4 Channel Control Register 0 (DM4CNT0)		DMA4 Channel Control Register 1 (DM4CNT1)		9-14 9-15
H'0080 0452	DMA4 Source Address Register (DM4SA)				9-30
H'0080 0454	DMA4 Destination Address Register (DM4DA)				9-31
H'0080 0456	DMA4 Transfer Count Register (DM4TCT)				9-32
H'0080 0458	DMA9 Channel Control Register 0 (DM9CNT0)		DMA9 Channel Control Register 1 (DM9CNT1)		9-24 9-25
H'0080 045A	DMA9 Source Address Register (DM9SA)				9-30
H'0080 045C	DMA9 Destination Address Register (DM9DA)				9-31
H'0080 045E	DMA9 Transfer Count Register (DM9TCT)				9-32
H'0080 0460	DMA0 Software Request Generation Register (DM0SRI)				9-29
H'0080 0462	DMA1 Software Request Generation Register (DM1SRI)				9-29
H'0080 0464	DMA2 Software Request Generation Register (DM2SRI)				9-29
H'0080 0466	DMA3 Software Request Generation Register (DM3SRI)				9-29
H'0080 0468	DMA4 Software Request Generation Register (DM4SRI)				9-29
	(Use inhibited area)				
H'0080 0470	DMA5 Software Request Generation Register (DM5SRI)				9-29
H'0080 0472	DMA6 Software Request Generation Register (DM6SRI)				9-29
H'0080 0474	DMA7 Software Request Generation Register (DM7SRI)				9-29
H'0080 0476	DMA8 Software Request Generation Register (DM8SRI)				9-29
H'0080 0478	DMA9 Software Request Generation Register (DM9SRI)				9-29
	(Use inhibited area)				
H'0080 0480	(Use inhibited area)		DMA0 Channel Control Register 2 (DM0CNT2)		9-26

SFR Area Register Map (11/37)

Address	+0 address		+1 address		See pages
	b0	b7	b8	b15	
H'0080 0482	(Use inhibited area)		DMA1 Channel Control Register 2 (DM1CNT2)		9-26
H'0080 0484	(Use inhibited area)		DMA2 Channel Control Register 2 (DM2CNT2)		9-26
H'0080 0486	(Use inhibited area)		DMA3 Channel Control Register 2 (DM3CNT2)		9-26
H'0080 0488	(Use inhibited area)		DMA4 Channel Control Register 2 (DM4CNT2)		9-26
	(Use inhibited area)				
H'0080 0490	(Use inhibited area)		DMA5 Channel Control Register 2 (DM5CNT2)		9-26
H'0080 0492	(Use inhibited area)		DMA6 Channel Control Register 2 (DM6CNT2)		9-26
H'0080 0494	(Use inhibited area)		DMA7 Channel Control Register 2 (DM7CNT2)		9-26
H'0080 0496	(Use inhibited area)		DMA8 Channel Control Register 2 (DM8CNT2)		9-26
H'0080 0498	(Use inhibited area)		DMA9 Channel Control Register 2 (DM9CNT2)		9-26
	(Use inhibited area)				
H'0080 0500	Port Group 0,1 Input Level Setting Register (PG01LEV)		Port Group 3 Input Level Setting Register (PG3LEV)		8-33
H'0080 0502	Port Group 4,5 Input Level Setting Register (PG45LEV)		Port Group 6,7 Input Level Setting Register (PG67LEV)		8-33
H'0080 0504	Port Group 8 Input Level Setting Register (PG8LEV)		(Use inhibited area)		8-33
H'0080 0506	(Use inhibited area)				
H'0080 0508	Port Group 0,1 Output Drive Capability Setting Register (PG01DRV)		Port Group 3 Output Drive Capability Setting Register (PG3DRV)		8-35
H'0080 050A	Port Group 4,5 Output Drive Capability Setting Register (PG45DRV)		Port Group 6,7 Output Drive Capability Setting Register (PG67DRV)		8-35
H'0080 050C	Port Group 8 Output Drive Capability Setting Register (PG8DRV)		P70 Output Drive Capability Setting Register (P70DRV)		8-35 8-36
H'0080 050E	(Use inhibited area)				
H'0080 0510	Noise Canceller Control Register (NZCNCLCR)				8-38
	(Use inhibited area)				
H'0080 0520	PWM Output 0 Disable Control Register GA (PO0DISGACR)		PWM Output 0 Disable Level Control Register GA (PO0LVGACR)		10-168 10-171
H'0080 0522	PWM Output 1 Disable Control Register GA (PO1DISGACR)		PWM Output 1 Disable Level Control Register GA (PO1LVGACR)		10-168 10-171
H'0080 0524	(Use inhibited area)				
H'0080 0526	PWMOFF 0 Function Enable Register (PWMOFF0EN)		PWMOFF 1 Function Enable Register (PWMOFF1EN)		10-173
H'0080 0528	(Use inhibited area)				
H'0080 052A	CAN Bus Mode Control Register (CANBUSCR)		DD Input Pin Select Register (DDSEL)		13-23 14-6
	(Use inhibited area)				
H'0080 0530	RAM Write Monitor Interrupt Status Register (RAMWRIST)				6-4
H'0080 0532	(Use inhibited area)				
H'0080 0534	RAM Write Source Status Register (RAMWRFST)				6-5
H'0080 0536	(Use inhibited area)				
H'0080 0538	RAM Write Disable Control Register (RAMWRCNT)				6-6
H'0080 053A	(Use inhibited area)				

SFR Area Register Map (12/37)

Address	+0 address		+1 address		See pages
	b0	b7	b8	b15	
H'0080 053C	(Use inhibited area)		RAM Write Disable Protect Register (RAMWRPROT)		6-7
	(Use inhibited area)				
H'0080 0600	Dummy Access area (Note1)		Dummy Access area (Note1)		3-46
H'0080 0602	Dummy Access area (Note1)		Dummy Access area (Note1)		3-46
	(Use inhibited area)				
H'0080 0700	P0 Data Register (P0DATA)		P1 Data Register (P1DATA)		8-12
H'0080 0702	P2 Data Register (P2DATA)		P3 Data Register (P3DATA)		8-12
H'0080 0704	P4 Data Register (P4DATA)		(Use inhibited area)		8-12
H'0080 0706	P6 Data Register (P6DATA)		P7 Data Register (P7DATA)		8-12
H'0080 0708	P8 Data Register (P8DATA)		P9 Data Register (P9DATA)		8-12
H'0080 070A	P10 Data Register (P10DATA)		P11 Data Register (P11DATA)		8-12
H'0080 070C	P12 Data Register (P12DATA)		P13 Data Register (P13DATA)		8-12
H'0080 070E	(Use inhibited area)		P15 Data Register (P15DATA)		8-12
H'0080 0710	(Use inhibited area)		P17 Data Register (P17DATA)		8-12
	(Use inhibited area)				
H'0080 0716	P22 Data Register (P22DATA)		(Use inhibited area)		8-12
	(Use inhibited area)				
H'0080 0720	P0 Direction Register (P0DIR)		P1 Direction Register (P1DIR)		8-13
H'0080 0722	P2 Direction Register (P2DIR)		P3 Direction Register (P3DIR)		8-13
H'0080 0724	P4 Direction Register (P4DIR)		(Use inhibited area)		8-13
H'0080 0726	P6 Direction Register (P6DIR)		P7 Direction Register (P7DIR)		8-13
H'0080 0728	P8 Direction Register (P8DIR)		P9 Direction Register (P9DIR)		8-13
H'0080 072A	P10 Direction Register (P10DIR)		P11 Direction Register (P11DIR)		8-13
H'0080 072C	P12 Direction Register (P12DIR)		P13 Direction Register (P13DIR)		8-13
H'0080 072E	(Use inhibited area)		P15 Direction Register (P15DIR)		8-13
H'0080 0730	(Use inhibited area)		P17 Direction Register (P17DIR)		8-13
	(Use inhibited area)				
H'0080 0736	P22 Direction Register (P22DIR)		(Use inhibited area)		8-13
	(Use inhibited area)				
H'0080 0740	P0 Operation Mode Register (P0MOD)		P1 Operation Mode Register (P1MOD)		8-14,17-5 8-15,17-7
H'0080 0742	P2 Operation Mode Register (P2MOD)		P3 Operation Mode Register (P3MOD)		8-16,17-8 8-17,17-9
H'0080 0744	P4 Operation Mode Register (P4MOD)		Port Input Special Function Control Register (PICNT)		8-18,17-10 8-29,20-3
H'0080 0746	(Use inhibited area)		P7 Operation Mode Register (P7MOD)		8-19,17-11 20-9
H'0080 0748	P8 Operation Mode Register (P8MOD)		P9 Operation Mode Register (P9MOD)		8-20 8-21
H'0080 074A	P10 Operation Mode Register (P10MOD)		P11 Operation Mode Register (P11MOD)		8-22 8-23

SFR Area Register Map (13/37)

Address	+0 address b0	b7	+1 address b8	b15	See pages
H'0080 074C	P12 Operation Mode Register (P12MOD)		P13 Operation Mode Register (P13MOD)		8-24, 17-12 8-25
H'0080 074E	(Use inhibited area)		P15 Operation Mode Register (P15MOD)		8-26, 17-13 20-10
H'0080 0750	(Use inhibited area)		P17 Operation Mode Register (P17MOD)		8-27
	(Use inhibited area)				
H'0080 0756	P22 Operation Mode Register (P22MOD)		(Use inhibited area)		8-28 17-14
	(Use inhibited area)				
H'0080 0760	P0 Peripheral Function Select Register (P0SMOD)		P1 Peripheral Function Select Register (P1SMOD)		8-14, 17-6 8-15, 17-7
H'0080 0762	(Use inhibited area)		P3 Peripheral Function Select Register (P3SMOD)		8-17 17-9
H'0080 0764	P4 Peripheral Function Select Register (P4SMOD)		(Use inhibited area)		8-18 17-10
H'0080 0766	(Use inhibited area)		P7 Peripheral Function Select Register (P7SMOD)		8-19, 17-11 20-9
H'0080 0768	P8 Peripheral Function Select Register (P8SMOD)		P9 Peripheral Function Select Register (P9SMOD)		8-20 8-21
H'0080 076A	P10 Peripheral Function Select Register (P10SMOD)		P11 Peripheral Function Select Register (P11SMOD)		8-22 8-23
H'0080 076C	P12 Peripheral Function Select Register (P12SMOD)		P13 Peripheral Function Select Register (P13SMOD)		8-24, 17-12 8-25
H'0080 076E	(Use inhibited area)		P15 Peripheral Function Select Register (P15SMOD)		8-26, 17-13 20-10
H'0080 0770	(Use inhibited area)		P17 Peripheral Function Select Register (P17SMOD)		8-27
	(Use inhibited area)				
H'0080 0776	P22 Peripheral Function Select Register (P22SMOD)		(Use inhibited area)		8-28 17-14
H'0080 0778	(Use inhibited area)				
H'0080 077A	(Use inhibited area)		RTD Write Function Disable Control Register (WRRDIS)		15-3
H'0080 077C	(Use inhibited area)				
H'0080 077E	(Use inhibited area)		Bus Mode Control Register (BUSMODC)		17-15
H'0080 0780	PWM Output 0 Disable Control Register GB (PO0DISGBCR)		PWM Output 0 Disable Level Control Register GB (PO0LVGBCR)		10-168 10-171
H'0080 0782	PWM Output 1 Disable Control Register GB (PO1DISGBCR)		PWM Output 1 Disable Level Control Register GB (PO1LVGBCR)		10-169 10-171
H'0080 0784	(Use inhibited area)				
H'0080 0786	Clock Control Register (CLKCR)		(Use inhibited area)		20-5
	(Use inhibited area)				
H'0080 078C	TID0 Counter (TID0CT)				10-140
H'0080 078E	TID0 Reload Register (TID0RL)				10-140
H'0080 0790	TOU0_0 Counter (TOU00CTW)		(Upper) (TOU00CTH)		10-157
H'0080 0792	-----		(Lower) (TOU00CT)		10-159
H'0080 0794	TOU0_0 Reload Register (TOU00RLW)		TOU0_0 Reload 1 Register (TOU00RL1)		10-160 10-162
H'0080 0796	-----		TOU0_0 Reload 0 Register (TOU00RL0)		10-161
H'0080 0798	TOU0_1 Counter (TOU01CTW)		(Upper) (TOU01CTH)		10-157
H'0080 079A	-----		(Lower) (TOU01CT)		10-159



SFR Area Register Map (14/37)

Address	+0 address		+1 address		See pages
	b0	b7 b8	b7 b8	b15	
H'0080 079C	TOU0_1 Reload Register (TOU01RLW)		TOU0_1 Reload 1 Register (TOU01RL1)		10-160 10-162
H'0080 079E			TOU0_1 Reload 0 Register (TOU01RL0)		10-161
H'0080 07A0	TOU0_2 Counter (TOU02CTW)		(Upper) (TOU02CTH)		10-157
H'0080 07A2			(Lower) (TOU02CT)		10-159
H'0080 07A4	TOU0_2 Reload Register (TOU02RLW)		TOU0_2 Reload 1 Register (TOU02RL1)		10-160 10-162
H'0080 07A6			TOU0_2 Reload 0 Register (TOU02RL0)		10-161
H'0080 07A8	TOU0_3 Counter (TOU03CTW)		(Upper) (TOU03CTH)		10-157
H'0080 07AA			(Lower) (TOU03CT)		10-159
H'0080 07AC	TOU0_3 Reload Register (TOU03RLW)		TOU0_3 Reload 1 Register (TOU03RL1)		10-160 10-162
H'0080 07AE			TOU0_3 Reload 0 Register (TOU03RL0)		10-161
H'0080 07B0	TOU0_4 Counter (TOU04CTW)		(Upper) (TOU04CTH)		10-157
H'0080 07B2			(Lower) (TOU04CT)		10-159
H'0080 07B4	TOU0_4 Reload Register (TOU04RLW)		TOU0_4 Reload 1 Register (TOU04RL1)		10-160 10-162
H'0080 07B6			TOU0_4 Reload 0 Register (TOU04RL0)		10-161
H'0080 07B8	TOU0_5 Counter (TOU05CTW)		(Upper) (TOU05CTH)		10-157
H'0080 07BA			(Lower) (TOU05CT)		10-159
H'0080 07BC	TOU0_5 Reload Register (TOU05RLW)		TOU0_5 Reload 1 Register (TOU05RL1)		10-160 10-162
H'0080 07BE			TOU0_5 Reload 0 Register (TOU05RL0)		10-161
H'0080 07C0	TOU0_6 Counter (TOU06CTW)		(Upper) (TOU06CTH)		10-157
H'0080 07C2			(Lower) (TOU06CT)		10-159
H'0080 07C4	TOU0_6 Reload Register (TOU06RLW)		TOU0_6 Reload 1 Register (TOU06RL1)		10-160 10-162
H'0080 07C6			TOU0_6 Reload 0 Register (TOU06RL0)		10-161
H'0080 07C8	TOU0_7 Counter (TOU07CTW)		(Upper) (TOU07CTH)		10-157
H'0080 07CA			(Lower) (TOU07CT)		10-159
H'0080 07CC	TOU0_7 Reload Register (TOU07RLW)		TOU0_7 Reload 1 Register (TOU07RL1)		10-160 10-162
H'0080 07CE			TOU0_7 Reload 0 Register (TOU07RL0)		10-161
H'0080 07D0	Prescaler Register 3 (PRS3)		TID0 Control & Prescaler 3 Enable Register (TID0PRS3EN)		10-13 10-138
H'0080 07D2	TOU0 Interrupt Request Mask Register (TOU0IMA)		TOU0 Interrupt Request Status Register (TOU0IST)		10-56
H'0080 07D4	Shorting Prevention Function F/F21-26 Protect Register (SHFF2126P)		F/F21-28 Protect Register (FF2128P)		10-155 10-31
H'0080 07D6	Shorting Prevention Function F/F21-26 Data Register (SHFF2126D)		F/F21-28 Data Register (FF2128D)		10-156 10-33
H'0080 07D8	TOU0 Control Register 1 (TOU0CR1)				10-153
H'0080 07DA	TOU0 Control Register 0 (TOU0CR0)				10-153
H'0080 07DC	(Use inhibited area)		TOU0 Enable Protect Register (TOU0PRO)		10-163
H'0080 07DE	(Use inhibited area)		TOU0 Count Enable Register (TOU0CEN)		10-164

## SFR Area Register Map (15/37)

Address	+0 address		+1 address		See pages
	b0	b7	b8	b15	
H'0080 07E0	PWMOFF0 Input Processing Control Register (PWMOFF0CR)		TIN24,25 Input Processing Control Register (TIN2425CR)		10-166 10-26
H'0080 07E2	TIN24,25 Interrupt Request Mask Register (TIN2425IMA)		TIN24,25 Interrupt Request Status Register (TIN2425IST)		10-52
	(Use inhibited area)				
H'0080 07E8	Virtual Flash L Bank Register 0 (FELBANK0)				6-24
H'0080 07EA	Virtual Flash L Bank Register 1 (FELBANK1)				6-24
H'0080 07EC	Virtual Flash L Bank Register 2 (FELBANK2)				6-24
H'0080 07EE	Virtual Flash L Bank Register 3 (FELBANK3)				6-24
H'0080 07F0	Virtual Flash L Bank Register 4 (Note 3) (FELBANK4)				6-24
H'0080 07F2	Virtual Flash L Bank Register 5 (Note 3) (FELBANK5)				6-24
H'0080 07F4	Virtual Flash L Bank Register 6 (Note 3) (FELBANK6)				6-24
H'0080 07F6	Virtual Flash L Bank Register 7 (Note 3) (FELBANK7)				6-24
H'0080 07F8	Virtual Flash L Bank Register 8 (Note 2) (FELBANK8)				6-24
H'0080 07FA	Virtual Flash L Bank Register 9 (Note 2) (FELBANK9)				6-24
H'0080 07FC	Virtual Flash L Bank Register 10 (Note 2) (FELBANK10)				6-24
H'0080 07FE	Virtual Flash L Bank Register 11 (Note 2) (FELBANK11)				6-24
H'0080 0800	Virtual Flash L Bank Register 12 (Note 2) (FELBANK12)				6-24
H'0080 0802	Virtual Flash L Bank Register 13 (Note 2) (FELBANK13)				6-24
H'0080 0804	Virtual Flash L Bank Register 14 (Note 2) (FELBANK14)				6-24
H'0080 0806	Virtual Flash L Bank Register 15 (Note 2) (FELBANK15)				6-24
	(Use inhibited area)				
H'0080 0A00	SIO45 Interrupt Request Status Register (SI45STAT)		SIO45 Interrupt Request Mask Register (SI45MASK)		12-9 12-10
H'0080 0A02	SIO45 Interrupt Request Source Select Register (SI45SEL)		(Use inhibited area)		12-11
	(Use inhibited area)				
H'0080 0A10	SIO4 Transmit Control Register (S4TCNT)		SIO4 Transmit/Receive Mode Register (S4MOD)		12-14 12-15
H'0080 0A12	SIO4 Transmit Buffer Register (S4TXB)				12-19
H'0080 0A14	SIO4 Receive Buffer Register (S4RXB)				12-20
H'0080 0A16	SIO4 Receive Control Register (S4RCNT)		SIO4 Baud Rate Register (S4BAUR)		12-21 12-24
H'0080 0A18	SIO4 Special Mode Register (S4SMOD)		(Use inhibited area)		12-27
	(Use inhibited area)				
H'0080 0A20	SIO5 Transmit Control Register (S5TCNT)		SIO5 Transmit/Receive Mode Register (S5MOD)		12-14 12-15
H'0080 0A22	SIO5 Transmit Buffer Register (S5TXB)				12-19
H'0080 0A24	SIO5 Receive Buffer Register (S5RXB)				12-20
H'0080 0A26	SIO5 Receive Control Register (S5RCNT)		SIO5 Baud Rate Register (S5BAUR)		12-21 12-24
H'0080 0A28	SIO5 Special Mode Register (S5SMOD)		(Use inhibited area)		12-27
	(Use inhibited area)				

SFR Area Register Map (16/37)

Address	+0 address		+1 address		See pages
	b0	b7 b8	b7 b8	b15	
H'0080 0B8C		TID1 Counter (TID1CT)			10-140
H'0080 0B8E		TID1 Reload Register (TID1RL)			10-140
H'0080 0B90		TOU1_0 Counter (TOU10CTW)		(Upper) (TOU10CTH)	10-157
H'0080 0B92				(Lower) (TOU10CT)	10-159
H'0080 0B94		TOU1_0 Reload Register (TOU10RLW)		TOU1_0 Reload 1 Register (TOU10RL1)	10-160 10-162
H'0080 0B96				TOU1_0 Reload 0 Register (TOU10RL0)	10-161
H'0080 0B98		TOU1_1 Counter (TOU11CTW)		(Upper) (TOU11CTH)	10-157
H'0080 0B9A				(Lower) (TOU11CT)	10-159
H'0080 0B9C		TOU1_1 Reload Register (TOU11RLW)		TOU1_1 Reload 1 Register (TOU11RL1)	10-160 10-162
H'0080 0B9E				TOU1_1 Reload 0 Register (TOU11RL0)	10-161
H'0080 0BA0		TOU1_2 Counter (TOU12CTW)		(Upper) (TOU12CTH)	10-157
H'0080 0BA2				(Lower) (TOU12CT)	10-159
H'0080 0BA4		TOU1_2 Reload Register (TOU12RLW)		TOU1_2 Reload 1 Register (TOU12RL1)	10-160 10-162
H'0080 0BA6				TOU1_2 Reload 0 Register (TOU12RL0)	10-161
H'0080 0BA8		TOU1_3 Counter (TOU13CTW)		(Upper) (TOU13CTH)	10-157
H'0080 0BAA				(Lower) (TOU13CT)	10-159
H'0080 0BAC		TOU1_3 Reload Register (TOU13RLW)		TOU1_3 Reload 1 Register (TOU13RL1)	10-160 10-162
H'0080 0BAE				TOU1_3 Reload 0 Register (TOU13RL0)	10-161
H'0080 0BB0		TOU1_4 Counter (TOU14CTW)		(Upper) (TOU14CTH)	10-157
H'0080 0BB2				(Lower) (TOU14CT)	10-159
H'0080 0BB4		TOU1_4 Reload Register (TOU14RLW)		TOU1_4 Reload 1 Register (TOU14RL1)	10-160 10-162
H'0080 0BB6				TOU1_4 Reload 0 Register (TOU14RL0)	10-161
H'0080 0BB8		TOU1_5 Counter (TOU15CTW)		(Upper) (TOU15CTH)	10-157
H'0080 0BBA				(Lower) (TOU15CT)	10-159
H'0080 0BBC		TOU1_5 Reload Register (TOU15RLW)		TOU1_5 Reload 1 Register (TOU15RL1)	10-160 10-162
H'0080 0BBE				TOU1_5 Reload 0 Register (TOU15RL0)	10-161
H'0080 0BC0		TOU1_6 Counter (TOU16CTW)		(Upper) (TOU16CTH)	10-157
H'0080 0BC2				(Lower) (TOU16CT)	10-159
H'0080 0BC4		TOU1_6 Reload Register (TOU16RLW)		TOU1_6 Reload 1 Register (TOU16RL1)	10-160 10-162
H'0080 0BC6				TOU1_6 Reload 0 Register (TOU16RL0)	10-161
H'0080 0BC8		TOU1_7 Counter (TOU17CTW)		(Upper) (TOU17CTH)	10-157
H'0080 0BCA				(Lower) (TOU17CT)	10-159
H'0080 0BCC		TOU1_7 Reload Register (TOU17RLW)		TOU1_7 Reload 1 Register (TOU17RL1)	10-160 10-162
H'0080 0BCE				TOU1_7 Reload 0 Register (TOU17RL0)	10-161

SFR Area Register Map (17/37)

Address	+0 address		+1 address		See pages
	b0	b7	b8	b15	
H'0080 0BD0	Prescaler Register 4 (PRS4)		TID1 Control & Prescaler 4 Enable Register (TID1PRS4EN)		10-13 10-139
H'0080 0BD2	TOU1 Interrupt Request Mask Register (TOU1IMA)		TOU1 Interrupt Request Status Register (TOU1IST)		10-58
H'0080 0BD4	Shorting Prevention Function F/F29-34 Protect Register (SHFF2934P)		F/F29-36 Protect Register (FF2936P)		10-155 10-31
H'0080 0BD6	Shorting Prevention Function F/F29-34 Data Register (SHFF2934D)		F/F29-36 Data Register (FF2936D)		10-156 10-33
H'0080 0BD8	TOU1 Control Register 1 (TOU1CR1)				10-154
H'0080 0BDA	TOU1 Control Register 0 (TOU1CR0)				10-154
H'0080 0BDC	(Use inhibited area)		TOU1 Enable Protect Register (TOU1PRO)		10-163
H'0080 0BDE	(Use inhibited area)		TOU1 Count Enable Register (TOU1CEN)		10-164
H'0080 0BE0	PWMOFF1 Input Processing Control Register (PWMOFF1CR)		TIN26,27 Input Processing Control Register (TIN2627CR)		10-166 10-26
H'0080 0BE2	TIN26,27 Interrupt Request Mask Register (TIN2627IMA)		TIN26,27 Interrupt Request Status Register (TIN2627IST)		10-53
	(Use inhibited area)				
H'0080 0FE0	TML1 Counter (TML1CT)		(Upper) (TML1CTH)		10-132
H'0080 0FE2	-----		(Lower) (TML1CTL)		
	(Use inhibited area)				
H'0080 0FEA	(Use inhibited area)		TML1 Control Register (TML1CR)		10-131
	(Use inhibited area)				
H'0080 0FF0	TML1 Measure 3 Register (TML1MR3)		(Upper) (TML1MR3H)		10-132
H'0080 0FF2	-----		(Lower) (TML1MR3L)		
H'0080 0FF4	TML1 Measure 2 Register (TML1MR2)		(Upper) (TML1MR2H)		10-132
H'0080 0FF6	-----		(Lower) (TML1MR2L)		
H'0080 0FF8	TML1 Measure 1 Register (TML1MR1)		(Upper) (TML1MR1H)		10-132
H'0080 0FFA	-----		(Lower) (TML1MR1L)		
H'0080 0FFC	TML1 Measure 0 Register (TML1MR0)		(Upper) (TML1MR0H)		10-132
H'0080 0FFE	-----		(Lower) (TML1MR0L)		

## SFR Area Register Map (18/37)

Address	+0 address		+1 address		See pages
	b0	b7	b8	b15	
H'0080 1000	CAN0 Control Register (CAN0CNT)				13-26
H'0080 1002	CAN0 Status Register (CAN0STAT)				13-29
H'0080 1004	(Use inhibited area)				
H'0080 1006	CAN0 Configuration Register (CAN0CONF)				13-32
H'0080 1008	CAN0 Timestamp Count Register (CAN0TSTMP)				13-35
H'0080 100A	CAN0 Receive Error Count Register (CAN0REC)		CAN0 Transmit Error Count Register (CAN0TEC)		13-36
H'0080 100C	CAN0 Slot Interrupt Request Status Register (CAN0SLISTW)				(Upper) 13-40 (CAN0SLIST)
H'0080 100E	----- (Lower) (CAN0SLISTL)				
H'0080 1010	CAN0 Slot Interrupt Request Mask Register (CAN0SLIMKW)				(Upper) 13-42 (CAN0SLIMK)
H'0080 1012	----- (Lower) (CAN0SLIMKL)				
H'0080 1014	CAN0 Error Interrupt Request Status Register (CAN0ERIST)		CAN0 Error Interrupt Request Mask Register (CAN0ERIMK)		13-43 13-44
H'0080 1016	CAN0 Baud Rate Prescaler (CAN0BRP)		CAN0 Cause of Error Register (CAN0EF)		13-37 13-67
H'0080 1018	CAN0 Mode Register (CAN0MOD)		CAN0 DMA Transfer Request Select Register (CAN0DMARQ)		13-69 13-70
H'0080 101A	CAN0 Message Slot Number Register (CAN0MSN)		CAN0 Clock Select Register (CAN0CKSEL)		13-71 13-72
H'0080 101C	CAN0 Frame Format Select Register (CAN0FFSW)				(Upper) 13-74 (CAN0FFS)
H'0080 101E	----- (Lower) (CAN0FFSL)				
H'0080 1020	CAN0 Global Mask Register A Standard ID0 (C0GMSKAS0)		CAN0 Global Mask Register A Standard ID1 (C0GMSKAS1)		13-76
H'0080 1022	CAN0 Global Mask Register A Extended ID0 (C0GMSKAE0)		CAN0 Global Mask Register A Extended ID1 (C0GMSKAE1)		13-77
H'0080 1024	CAN0 Global Mask Register A Extended ID2 (C0GMSKAE2)		(Use inhibited area)		13-78
H'0080 1026	(Use inhibited area)				
H'0080 1028	CAN0 Global Mask Register B Standard ID0 (C0GMSKBS0)		CAN0 Global Mask Register B Standard ID1 (C0GMSKBS1)		13-76
H'0080 102A	CAN0 Global Mask Register B Extended ID0 (C0GMSKBE0)		CAN0 Global Mask Register B Extended ID1 (C0GMSKBE1)		13-77
H'0080 102C	CAN0 Global Mask Register B Extended ID2 (C0GMSKBE2)		(Use inhibited area)		13-78
H'0080 102E	(Use inhibited area)				
H'0080 1030	CAN0 Local Mask Register A Standard ID0 (C0LMSKAS0)		CAN0 Local Mask Register A Standard ID1 (C0LMSKAS1)		13-76
H'0080 1032	CAN0 Local Mask Register A Extended ID0 (C0LMSKAE0)		CAN0 Local Mask Register A Extended ID1 (C0LMSKAE1)		13-77
H'0080 1034	CAN0 Local Mask Register A Extended ID2 (C0LMSKAE2)		(Use inhibited area)		13-78
H'0080 1036	(Use inhibited area)				
H'0080 1038	CAN0 Local Mask Register B Standard ID0 (C0LMSKBS0)		CAN0 Local Mask Register B Standard ID1 (C0LMSKBS1)		13-76
H'0080 103A	CAN0 Local Mask Register B Extended ID0 (C0LMSKBE0)		CAN0 Local Mask Register B Extended ID1 (C0LMSKBE1)		13-77
H'0080 103C	CAN0 Local Mask Register B Extended ID2 (C0LMSKBE2)		(Use inhibited area)		13-78
H'0080 103E	(Use inhibited area)				
H'0080 1040	CAN0 Single-Shot Mode Control Register (CAN0SSMODEW)				(Upper) 13-80 (CAN0SSMODE)
H'0080 1042	----- (Lower) (CAN0SSMODEL)				

## SFR Area Register Map (19/37)

Address	+0 address		+1 address		See pages
	b0	b7	b8	b15	
H'0080 1044	CAN0 Single-Shot Interrupt Request Status Register (CAN0SSISTW)		(Upper) (CAN0SSIST)		13-45
H'0080 1046			(Lower) (CAN0SSISTL)		
H'0080 1048	CAN0 Single-Shot Interrupt Request Mask Register (CAN0SSIMKW)		(Upper) (CAN0SSIMK)		13-47
H'0080 104A			(Lower) (CAN0SSIMKL)		
	(Use inhibited area)				
H'0080 1050	CAN0 Message Slot 0 Control Register (C0MSL0CNT)		CAN0 Message Slot 1 Control Register (C0MSL1CNT)		13-82
H'0080 1052	CAN0 Message Slot 2 Control Register (C0MSL2CNT)		CAN0 Message Slot 3 Control Register (C0MSL3CNT)		13-82
H'0080 1054	CAN0 Message Slot 4 Control Register (C0MSL4CNT)		CAN0 Message Slot 5 Control Register (C0MSL5CNT)		13-82
H'0080 1056	CAN0 Message Slot 6 Control Register (C0MSL6CNT)		CAN0 Message Slot 7 Control Register (C0MSL7CNT)		13-82
H'0080 1058	CAN0 Message Slot 8 Control Register (C0MSL8CNT)		CAN0 Message Slot 9 Control Register (C0MSL9CNT)		13-82
H'0080 105A	CAN0 Message Slot 10 Control Register (C0MSL10CNT)		CAN0 Message Slot 11 Control Register (C0MSL11CNT)		13-82
H'0080 105C	CAN0 Message Slot 12 Control Register (C0MSL12CNT)		CAN0 Message Slot 13 Control Register (C0MSL13CNT)		13-82
H'0080 105E	CAN0 Message Slot 14 Control Register (C0MSL14CNT)		CAN0 Message Slot 15 Control Register (C0MSL15CNT)		13-82
H'0080 1060	CAN0 Message Slot 16 Control Register (C0MSL16CNT)		CAN0 Message Slot 17 Control Register (C0MSL17CNT)		13-82
H'0080 1062	CAN0 Message Slot 18 Control Register (C0MSL18CNT)		CAN0 Message Slot 19 Control Register (C0MSL19CNT)		13-82
H'0080 1064	CAN0 Message Slot 20 Control Register (C0MSL20CNT)		CAN0 Message Slot 21 Control Register (C0MSL21CNT)		13-82
H'0080 1066	CAN0 Message Slot 22 Control Register (C0MSL22CNT)		CAN0 Message Slot 23 Control Register (C0MSL23CNT)		13-82
H'0080 1068	CAN0 Message Slot 24 Control Register (C0MSL24CNT)		CAN0 Message Slot 25 Control Register (C0MSL25CNT)		13-82
H'0080 106A	CAN0 Message Slot 26 Control Register (C0MSL26CNT)		CAN0 Message Slot 27 Control Register (C0MSL27CNT)		13-82
H'0080 106C	CAN0 Message Slot 28 Control Register (C0MSL28CNT)		CAN0 Message Slot 29 Control Register (C0MSL29CNT)		13-82
H'0080 106E	CAN0 Message Slot 30 Control Register (C0MSL30CNT)		CAN0 Message Slot 31 Control Register (C0MSL31CNT)		13-82
	(Use inhibited area)				
H'0080 1100	CAN0 Message Slot 0 Standard ID0 (C0MSL0SID0)		CAN0 Message Slot 0 Standard ID1 (C0MSL0SID1)		13-86 13-88
H'0080 1102	CAN0 Message Slot 0 Extended ID0 (C0MSL0EID0)		CAN0 Message Slot 0 Extended ID1 (C0MSL0EID1)		13-90 13-92
H'0080 1104	CAN0 Message Slot 0 Extended ID2 (C0MSL0EID2)		CAN0 Message Slot 0 Data Length Register (C0MSL0DLC)		13-94 13-96
H'0080 1106	CAN0 Message Slot 0 Data 0 (C0MSL0DT0)		CAN0 Message Slot 0 Data 1 (C0MSL0DT1)		13-98 13-100
H'0080 1108	CAN0 Message Slot 0 Data 2 (C0MSL0DT2)		CAN0 Message Slot 0 Data 3 (C0MSL0DT3)		13-102 13-104
H'0080 110A	CAN0 Message Slot 0 Data 4 (C0MSL0DT4)		CAN0 Message Slot 0 Data 5 (C0MSL0DT5)		13-106 13-108
H'0080 110C	CAN0 Message Slot 0 Data 6 (C0MSL0DT6)		CAN0 Message Slot 0 Data 7 (C0MSL0DT7)		13-110 13-112
H'0080 110E	CAN0 Message Slot 0 Timestamp (C0MSL0TSP)				13-114
H'0080 1110	CAN0 Message Slot 1 Standard ID0 (C0MSL1SID0)		CAN0 Message Slot 1 Standard ID1 (C0MSL1SID1)		13-86 13-88
H'0080 1112	CAN0 Message Slot 1 Extended ID0 (C0MSL1EID0)		CAN0 Message Slot 1 Extended ID1 (C0MSL1EID1)		13-90 13-92
H'0080 1114	CAN0 Message Slot 1 Extended ID2 (C0MSL1EID2)		CAN0 Message Slot 1 Data Length Register (C0MSL1DLC)		13-94 13-96
H'0080 1116	CAN0 Message Slot 1 Data 0 (C0MSL1DT0)		CAN0 Message Slot 1 Data 1 (C0MSL1DT1)		13-98 13-100
H'0080 1118	CAN0 Message Slot 1 Data 2 (C0MSL1DT2)		CAN0 Message Slot 1 Data 3 (C0MSL1DT3)		13-102 13-104



## SFR Area Register Map (20/37)

Address	+0 address		+1 address		See pages
	b0	b7	b8	b15	
H'0080 111A	CAN0 Message Slot 1 Data 4 (C0MSL1DT4)		CAN0 Message Slot 1 Data 5 (C0MSL1DT5)		13-106 13-108
H'0080 111C	CAN0 Message Slot 1 Data 6 (C0MSL1DT6)		CAN0 Message Slot 1 Data 7 (C0MSL1DT7)		13-110 13-112
H'0080 111E	CAN0 Message Slot 1 Timestamp (C0MSL1TSP)				13-114
H'0080 1120	CAN0 Message Slot 2 Standard ID0 (C0MSL2SID0)		CAN0 Message Slot 2 Standard ID1 (C0MSL2SID1)		13-86 13-88
H'0080 1122	CAN0 Message Slot 2 Extended ID0 (C0MSL2EID0)		CAN0 Message Slot 2 Extended ID1 (C0MSL2EID1)		13-90 13-92
H'0080 1124	CAN0 Message Slot 2 Extended ID2 (C0MSL2EID2)		CAN0 Message Slot 2 Data Length Register (C0MSL2DLC)		13-94 13-96
H'0080 1126	CAN0 Message Slot 2 Data 0 (C0MSL2DT0)		CAN0 Message Slot 2 Data 1 (C0MSL2DT1)		13-98 13-100
H'0080 1128	CAN0 Message Slot 2 Data 2 (C0MSL2DT2)		CAN0 Message Slot 2 Data 3 (C0MSL2DT3)		13-102 13-104
H'0080 112A	CAN0 Message Slot 2 Data 4 (C0MSL2DT4)		CAN0 Message Slot 2 Data 5 (C0MSL2DT5)		13-106 13-108
H'0080 112C	CAN0 Message Slot 2 Data 6 (C0MSL2DT6)		CAN0 Message Slot 2 Data 7 (C0MSL2DT7)		13-110 13-112
H'0080 112E	CAN0 Message Slot 2 Timestamp (C0MSL2TSP)				13-114
H'0080 1130	CAN0 Message Slot 3 Standard ID0 (C0MSL3SID0)		CAN0 Message Slot 3 Standard ID1 (C0MSL3SID1)		13-86 13-88
H'0080 1132	CAN0 Message Slot 3 Extended ID0 (C0MSL3EID0)		CAN0 Message Slot 3 Extended ID1 (C0MSL3EID1)		13-90 13-92
H'0080 1134	CAN0 Message Slot 3 Extended ID2 (C0MSL3EID2)		CAN0 Message Slot 3 Data Length Register (C0MSL3DLC)		13-94 13-96
H'0080 1136	CAN0 Message Slot 3 Data 0 (C0MSL3DT0)		CAN0 Message Slot 3 Data 1 (C0MSL3DT1)		13-98 13-100
H'0080 1138	CAN0 Message Slot 3 Data 2 (C0MSL3DT2)		CAN0 Message Slot 3 Data 3 (C0MSL3DT3)		13-102 13-104
H'0080 113A	CAN0 Message Slot 3 Data 4 (C0MSL3DT4)		CAN0 Message Slot 3 Data 5 (C0MSL3DT5)		13-106 13-108
H'0080 113C	CAN0 Message Slot 3 Data 6 (C0MSL3DT6)		CAN0 Message Slot 3 Data 7 (C0MSL3DT7)		13-110 13-112
H'0080 113E	CAN0 Message Slot 3 Timestamp (C0MSL3TSP)				13-114
H'0080 1140	CAN0 Message Slot 4 Standard ID0 (C0MSL4SID0)		CAN0 Message Slot 4 Standard ID1 (C0MSL4SID1)		13-86 13-88
H'0080 1142	CAN0 Message Slot 4 Extended ID0 (C0MSL4EID0)		CAN0 Message Slot 4 Extended ID1 (C0MSL4EID1)		13-90 13-92
H'0080 1144	CAN0 Message Slot 4 Extended ID2 (C0MSL4EID2)		CAN0 Message Slot 4 Data Length Register (C0MSL4DLC)		13-94 13-96
H'0080 1146	CAN0 Message Slot 4 Data 0 (C0MSL4DT0)		CAN0 Message Slot 4 Data 1 (C0MSL4DT1)		13-98 13-100
H'0080 1148	CAN0 Message Slot 4 Data 2 (C0MSL4DT2)		CAN0 Message Slot 4 Data 3 (C0MSL4DT3)		13-102 13-104
H'0080 114A	CAN0 Message Slot 4 Data 4 (C0MSL4DT4)		CAN0 Message Slot 4 Data 5 (C0MSL4DT5)		13-106 13-108
H'0080 114C	CAN0 Message Slot 4 Data 6 (C0MSL4DT6)		CAN0 Message Slot 4 Data 7 (C0MSL4DT7)		13-110 13-112
H'0080 114E	CAN0 Message Slot 4 Timestamp (C0MSL4TSP)				13-114
H'0080 1150	CAN0 Message Slot 5 Standard ID0 (C0MSL5SID0)		CAN0 Message Slot 5 Standard ID1 (C0MSL5SID1)		13-86 13-88
H'0080 1152	CAN0 Message Slot 5 Extended ID0 (C0MSL5EID0)		CAN0 Message Slot 5 Extended ID1 (C0MSL5EID1)		13-90 13-92
H'0080 1154	CAN0 Message Slot 5 Extended ID2 (C0MSL5EID2)		CAN0 Message Slot 5 Data Length Register (C0MSL5DLC)		13-94 13-96
H'0080 1156	CAN0 Message Slot 5 Data 0 (C0MSL5DT0)		CAN0 Message Slot 5 Data 1 (C0MSL5DT1)		13-98 13-100
H'0080 1158	CAN0 Message Slot 5 Data 2 (C0MSL5DT2)		CAN0 Message Slot 5 Data 3 (C0MSL5DT3)		13-102 13-104
H'0080 115A	CAN0 Message Slot 5 Data 4 (C0MSL5DT4)		CAN0 Message Slot 5 Data 5 (C0MSL5DT5)		13-106 13-108
H'0080 115C	CAN0 Message Slot 5 Data 6 (C0MSL5DT6)		CAN0 Message Slot 5 Data 7 (C0MSL5DT7)		13-110 13-112
H'0080 115E	CAN0 Message Slot 5 Timestamp (C0MSL5TSP)				13-114

SFR Area Register Map (21/37)

Address	+0 address		+1 address		See pages
	b0	b7	b8	b15	
H'0080 1160	CAN0 Message Slot 6 Standard ID0 (C0MSL6SID0)		CAN0 Message Slot 6 Standard ID1 (C0MSL6SID1)		13-86 13-88
H'0080 1162	CAN0 Message Slot 6 Extended ID0 (C0MSL6EID0)		CAN0 Message Slot 6 Extended ID1 (C0MSL6EID1)		13-90 13-92
H'0080 1164	CAN0 Message Slot 6 Extended ID2 (C0MSL6EID2)		CAN0 Message Slot 6 Data Length Register (C0MSL6DLC)		13-94 13-96
H'0080 1166	CAN0 Message Slot 6 Data 0 (C0MSL6DT0)		CAN0 Message Slot 6 Data 1 (C0MSL6DT1)		13-98 13-100
H'0080 1168	CAN0 Message Slot 6 Data 2 (C0MSL6DT2)		CAN0 Message Slot 6 Data 3 (C0MSL6DT3)		13-102 13-104
H'0080 116A	CAN0 Message Slot 6 Data 4 (C0MSL6DT4)		CAN0 Message Slot 6 Data 5 (C0MSL6DT5)		13-106 13-108
H'0080 116C	CAN0 Message Slot 6 Data 6 (C0MSL6DT6)		CAN0 Message Slot 6 Data 7 (C0MSL6DT7)		13-110 13-112
H'0080 116E	CAN0 Message Slot 6 Timestamp (C0MSL6TSP)				13-114
H'0080 1170	CAN0 Message Slot 7 Standard ID0 (C0MSL7SID0)		CAN0 Message Slot 7 Standard ID1 (C0MSL7SID1)		13-86 13-88
H'0080 1172	CAN0 Message Slot 7 Extended ID0 (C0MSL7EID0)		CAN0 Message Slot 7 Extended ID1 (C0MSL7EID1)		13-90 13-92
H'0080 1174	CAN0 Message Slot 7 Extended ID2 (C0MSL7EID2)		CAN0 Message Slot 7 Data Length Register (C0MSL7DLC)		13-94 13-96
H'0080 1176	CAN0 Message Slot 7 Data 0 (C0MSL7DT0)		CAN0 Message Slot 7 Data 1 (C0MSL7DT1)		13-98 13-100
H'0080 1178	CAN0 Message Slot 7 Data 2 (C0MSL7DT2)		CAN0 Message Slot 7 Data 3 (C0MSL7DT3)		13-102 13-104
H'0080 117A	CAN0 Message Slot 7 Data 4 (C0MSL7DT4)		CAN0 Message Slot 7 Data 5 (C0MSL7DT5)		13-106 13-108
H'0080 117C	CAN0 Message Slot 7 Data 6 (C0MSL7DT6)		CAN0 Message Slot 7 Data 7 (C0MSL7DT7)		13-110 13-112
H'0080 117E	CAN0 Message Slot 7 Timestamp (C0MSL7TSP)				13-114
H'0080 1180	CAN0 Message Slot 8 Standard ID0 (C0MSL8SID0)		CAN0 Message Slot 8 Standard ID1 (C0MSL8SID1)		13-86 13-88
H'0080 1182	CAN0 Message Slot 8 Extended ID0 (C0MSL8EID0)		CAN0 Message Slot 8 Extended ID1 (C0MSL8EID1)		13-90 13-92
H'0080 1184	CAN0 Message Slot 8 Extended ID2 (C0MSL8EID2)		CAN0 Message Slot 8 Data Length Register (C0MSL8DLC)		13-94 13-96
H'0080 1186	CAN0 Message Slot 8 Data 0 (C0MSL8DT0)		CAN0 Message Slot 8 Data 1 (C0MSL8DT1)		13-98 13-100
H'0080 1188	CAN0 Message Slot 8 Data 2 (C0MSL8DT2)		CAN0 Message Slot 8 Data 3 (C0MSL8DT3)		13-102 13-104
H'0080 118A	CAN0 Message Slot 8 Data 4 (C0MSL8DT4)		CAN0 Message Slot 8 Data 5 (C0MSL8DT5)		13-106 13-108
H'0080 118C	CAN0 Message Slot 8 Data 6 (C0MSL8DT6)		CAN0 Message Slot 8 Data 7 (C0MSL8DT7)		13-110 13-112
H'0080 118E	CAN0 Message Slot 8 Timestamp (C0MSL8TSP)				13-114
H'0080 1190	CAN0 Message Slot 9 Standard ID0 (C0MSL9SID0)		CAN0 Message Slot 9 Standard ID1 (C0MSL9SID1)		13-86 13-88
H'0080 1192	CAN0 Message Slot 9 Extended ID0 (C0MSL9EID0)		CAN0 Message Slot 9 Extended ID1 (C0MSL9EID1)		13-90 13-92
H'0080 1194	CAN0 Message Slot 9 Extended ID2 (C0MSL9EID2)		CAN0 Message Slot 9 Data Length Register (C0MSL9DLC)		13-94 13-96
H'0080 1196	CAN0 Message Slot 9 Data 0 (C0MSL9DT0)		CAN0 Message Slot 9 Data 1 (C0MSL9DT1)		13-98 13-100
H'0080 1198	CAN0 Message Slot 9 Data 2 (C0MSL9DT2)		CAN0 Message Slot 9 Data 3 (C0MSL9DT3)		13-102 13-104
H'0080 119A	CAN0 Message Slot 9 Data 4 (C0MSL9DT4)		CAN0 Message Slot 9 Data 5 (C0MSL9DT5)		13-106 13-108
H'0080 119C	CAN0 Message Slot 9 Data 6 (C0MSL9DT6)		CAN0 Message Slot 9 Data 7 (C0MSL9DT7)		13-110 13-112
H'0080 119E	CAN0 Message Slot 9 Timestamp (C0MSL9TSP)				13-114
H'0080 11A0	CAN0 Message Slot 10 Standard ID0 (C0MSL10SID0)		CAN0 Message Slot 10 Standard ID1 (C0MSL10SID1)		13-86 13-88
H'0080 11A2	CAN0 Message Slot 10 Extended ID0 (C0MSL10EID0)		CAN0 Message Slot 10 Extended ID1 (C0MSL10EID1)		13-90 13-92
H'0080 11A4	CAN0 Message Slot 10 Extended ID2 (C0MSL10EID2)		CAN0 Message Slot 10 Data Length Register (C0MSL10DLC)		13-94 13-96



SFR Area Register Map (22/37)

Address	+0 address		+1 address		See pages
	b0	b7	b8	b15	
H'0080 11A6	CAN0 Message Slot 10 Data 0 (C0MSL10DT0)		CAN0 Message Slot 10 Data 1 (C0MSL10DT1)		13-98 13-100
H'0080 11A8	CAN0 Message Slot 10 Data 2 (C0MSL10DT2)		CAN0 Message Slot 10 Data 3 (C0MSL10DT3)		13-102 13-104
H'0080 11AA	CAN0 Message Slot 10 Data 4 (C0MSL10DT4)		CAN0 Message Slot 10 Data 5 (C0MSL10DT5)		13-106 13-108
H'0080 11AC	CAN0 Message Slot 10 Data 6 (C0MSL10DT6)		CAN0 Message Slot 10 Data 7 (C0MSL10DT7)		13-110 13-112
H'0080 11AE	CAN0 Message Slot 10 Timestamp (C0MSL10TSP)				13-114
H'0080 11B0	CAN0 Message Slot 11 Standard ID0 (C0MSL11SID0)		CAN0 Message Slot 11 Standard ID1 (C0MSL11SID1)		13-86 13-88
H'0080 11B2	CAN0 Message Slot 11 Extended ID0 (C0MSL11EID0)		CAN0 Message Slot 11 Extended ID1 (C0MSL11EID1)		13-90 13-92
H'0080 11B4	CAN0 Message Slot 11 Extended ID2 (C0MSL11EID2)		CAN0 Message Slot 11 Data Length Register (C0MSL11DLC)		13-94 13-96
H'0080 11B6	CAN0 Message Slot 11 Data 0 (C0MSL11DT0)		CAN0 Message Slot 11 Data 1 (C0MSL11DT1)		13-98 13-100
H'0080 11B8	CAN0 Message Slot 11 Data 2 (C0MSL11DT2)		CAN0 Message Slot 11 Data 3 (C0MSL11DT3)		13-102 13-104
H'0080 11BA	CAN0 Message Slot 11 Data 4 (C0MSL11DT4)		CAN0 Message Slot 11 Data 5 (C0MSL11DT5)		13-106 13-108
H'0080 11BC	CAN0 Message Slot 11 Data 6 (C0MSL11DT6)		CAN0 Message Slot 11 Data 7 (C0MSL11DT7)		13-110 13-112
H'0080 11BE	CAN0 Message Slot 11 Timestamp (C0MSL11TSP)				13-114
H'0080 11C0	CAN0 Message Slot 12 Standard ID0 (C0MSL12SID0)		CAN0 Message Slot 12 Standard ID1 (C0MSL12SID1)		13-86 13-88
H'0080 11C2	CAN0 Message Slot 12 Extended ID0 (C0MSL12EID0)		CAN0 Message Slot 12 Extended ID1 (C0MSL12EID1)		13-90 13-92
H'0080 11C4	CAN0 Message Slot 12 Extended ID2 (C0MSL12EID2)		CAN0 Message Slot 12 Data Length Register (C0MSL12DLC)		13-94 13-96
H'0080 11C6	CAN0 Message Slot 12 Data 0 (C0MSL12DT0)		CAN0 Message Slot 12 Data 1 (C0MSL12DT1)		13-98 13-100
H'0080 11C8	CAN0 Message Slot 12 Data 2 (C0MSL12DT2)		CAN0 Message Slot 12 Data 3 (C0MSL12DT3)		13-102 13-104
H'0080 11CA	CAN0 Message Slot 12 Data 4 (C0MSL12DT4)		CAN0 Message Slot 12 Data 5 (C0MSL12DT5)		13-106 13-108
H'0080 11CC	CAN0 Message Slot 12 Data 6 (C0MSL12DT6)		CAN0 Message Slot 12 Data 7 (C0MSL12DT7)		13-110 13-112
H'0080 11CE	CAN0 Message Slot 12 Timestamp (C0MSL12TSP)				13-114
H'0080 11D0	CAN0 Message Slot 13 Standard ID0 (C0MSL13SID0)		CAN0 Message Slot 13 Standard ID1 (C0MSL13SID1)		13-86 13-88
H'0080 11D2	CAN0 Message Slot 13 Extended ID0 (C0MSL13EID0)		CAN0 Message Slot 13 Extended ID1 (C0MSL13EID1)		13-90 13-92
H'0080 11D4	CAN0 Message Slot 13 Extended ID2 (C0MSL13EID2)		CAN0 Message Slot 13 Data Length Register (C0MSL13DLC)		13-94 13-96
H'0080 11D6	CAN0 Message Slot 13 Data 0 (C0MSL13DT0)		CAN0 Message Slot 13 Data 1 (C0MSL13DT1)		13-98 13-100
H'0080 11D8	CAN0 Message Slot 13 Data 2 (C0MSL13DT2)		CAN0 Message Slot 13 Data 3 (C0MSL13DT3)		13-102 13-104
H'0080 11DA	CAN0 Message Slot 13 Data 4 (C0MSL13DT4)		CAN0 Message Slot 13 Data 5 (C0MSL13DT5)		13-106 13-108
H'0080 11DC	CAN0 Message Slot 13 Data 6 (C0MSL13DT6)		CAN0 Message Slot 13 Data 7 (C0MSL13DT7)		13-110 13-112
H'0080 11DE	CAN0 Message Slot 13 Timestamp (C0MSL13TSP)				13-114
H'0080 11E0	CAN0 Message Slot 14 Standard ID0 (C0MSL14SID0)		CAN0 Message Slot 14 Standard ID1 (C0MSL14SID1)		13-86 13-88
H'0080 11E2	CAN0 Message Slot 14 Extended ID0 (C0MSL14EID0)		CAN0 Message Slot 14 Extended ID1 (C0MSL14EID1)		13-90 13-92
H'0080 11E4	CAN0 Message Slot 14 Extended ID2 (C0MSL14EID2)		CAN0 Message Slot 14 Data Length Register (C0MSL14DLC)		13-94 13-96
H'0080 11E6	CAN0 Message Slot 14 Data 0 (C0MSL14DT0)		CAN0 Message Slot 14 Data 1 (C0MSL14DT1)		13-98 13-100
H'0080 11E8	CAN0 Message Slot 14 Data 2 (C0MSL14DT2)		CAN0 Message Slot 14 Data 3 (C0MSL14DT3)		13-102 13-104
H'0080 11EA	CAN0 Message Slot 14 Data 4 (C0MSL14DT4)		CAN0 Message Slot 14 Data 5 (C0MSL14DT5)		13-106 13-108

SFR Area Register Map (23/37)

Address	+0 address		+1 address		See pages
	b0	b7	b8	b15	
H'0080 11EC	CAN0 Message Slot 14 Data 6 (C0MSL14DT6)		CAN0 Message Slot 14 Data 7 (C0MSL14DT7)		13-110 13-112
H'0080 11EE	CAN0 Message Slot 14 Timestamp (C0MSL14TSP)				13-114
H'0080 11F0	CAN0 Message Slot 15 Standard ID0 (C0MSL15SID0)		CAN0 Message Slot 15 Standard ID1 (C0MSL15SID1)		13-86 13-88
H'0080 11F2	CAN0 Message Slot 15 Extended ID0 (C0MSL15EID0)		CAN0 Message Slot 15 Extended ID1 (C0MSL15EID1)		13-90 13-92
H'0080 11F4	CAN0 Message Slot 15 Extended ID2 (C0MSL15EID2)		CAN0 Message Slot 15 Data Length Register (C0MSL15DLC)		13-94 13-96
H'0080 11F6	CAN0 Message Slot 15 Data 0 (C0MSL15DT0)		CAN0 Message Slot 15 Data 1 (C0MSL15DT1)		13-98 13-100
H'0080 11F8	CAN0 Message Slot 15 Data 2 (C0MSL15DT2)		CAN0 Message Slot 15 Data 3 (C0MSL15DT3)		13-102 13-104
H'0080 11FA	CAN0 Message Slot 15 Data 4 (C0MSL15DT4)		CAN0 Message Slot 15 Data 5 (C0MSL15DT5)		13-106 13-108
H'0080 11FC	CAN0 Message Slot 15 Data 6 (C0MSL15DT6)		CAN0 Message Slot 15 Data 7 (C0MSL15DT7)		13-110 13-112
H'0080 11FE	CAN0 Message Slot 15 Timestamp (C0MSL15TSP)				13-114
H'0080 1200	CAN0 Message Slot 16 Standard ID0 (C0MSL16SID0)		CAN0 Message Slot 16 Standard ID1 (C0MSL16SID1)		13-86 13-88
H'0080 1202	CAN0 Message Slot 16 Extended ID0 (C0MSL16EID0)		CAN0 Message Slot 16 Extended ID1 (C0MSL16EID1)		13-90 13-92
H'0080 1204	CAN0 Message Slot 16 Extended ID2 (C0MSL16EID2)		CAN0 Message Slot 16 Data Length Register (C0MSL16DLC)		13-94 13-96
H'0080 1206	CAN0 Message Slot 16 Data 0 (C0MSL16DT0)		CAN0 Message Slot 16 Data 1 (C0MSL16DT1)		13-98 13-100
H'0080 1208	CAN0 Message Slot 16 Data 2 (C0MSL16DT2)		CAN0 Message Slot 16 Data 3 (C0MSL16DT3)		13-102 13-104
H'0080 120A	CAN0 Message Slot 16 Data 4 (C0MSL16DT4)		CAN0 Message Slot 16 Data 5 (C0MSL16DT5)		13-106 13-108
H'0080 120C	CAN0 Message Slot 16 Data 6 (C0MSL16DT6)		CAN0 Message Slot 16 Data 7 (C0MSL16DT7)		13-110 13-112
H'0080 120E	CAN0 Message Slot 16 Timestamp (C0MSL16TSP)				13-114
H'0080 1210	CAN0 Message Slot 17 Standard ID0 (C0MSL17SID0)		CAN0 Message Slot 17 Standard ID1 (C0MSL17SID1)		13-86 13-88
H'0080 1212	CAN0 Message Slot 17 Extended ID0 (C0MSL17EID0)		CAN0 Message Slot 17 Extended ID1 (C0MSL17EID1)		13-90 13-92
H'0080 1214	CAN0 Message Slot 17 Extended ID2 (C0MSL17EID2)		CAN0 Message Slot 17 Data Length Register (C0MSL17DLC)		13-94 13-96
H'0080 1216	CAN0 Message Slot 17 Data 0 (C0MSL17DT0)		CAN0 Message Slot 17 Data 1 (C0MSL17DT1)		13-98 13-100
H'0080 1218	CAN0 Message Slot 17 Data 2 (C0MSL17DT2)		CAN0 Message Slot 17 Data 3 (C0MSL17DT3)		13-102 13-104
H'0080 121A	CAN0 Message Slot 17 Data 4 (C0MSL17DT4)		CAN0 Message Slot 17 Data 5 (C0MSL17DT5)		13-106 13-108
H'0080 121C	CAN0 Message Slot 17 Data 6 (C0MSL17DT6)		CAN0 Message Slot 17 Data 7 (C0MSL17DT7)		13-110 13-112
H'0080 121E	CAN0 Message Slot 17 Timestamp (C0MSL17TSP)				13-114
H'0080 1220	CAN0 Message Slot 18 Standard ID0 (C0MSL18SID0)		CAN0 Message Slot 18 Standard ID1 (C0MSL18SID1)		13-86 13-88
H'0080 1222	CAN0 Message Slot 18 Extended ID0 (C0MSL18EID0)		CAN0 Message Slot 18 Extended ID1 (C0MSL18EID1)		13-90 13-92
H'0080 1224	CAN0 Message Slot 18 Extended ID2 (C0MSL18EID2)		CAN0 Message Slot 18 Data Length Register (C0MSL18DLC)		13-94 13-96
H'0080 1226	CAN0 Message Slot 18 Data 0 (C0MSL18DT0)		CAN0 Message Slot 18 Data 1 (C0MSL18DT1)		13-98 13-100
H'0080 1228	CAN0 Message Slot 18 Data 2 (C0MSL18DT2)		CAN0 Message Slot 18 Data 3 (C0MSL18DT3)		13-102 13-104
H'0080 122A	CAN0 Message Slot 18 Data 4 (C0MSL18DT4)		CAN0 Message Slot 18 Data 5 (C0MSL18DT5)		13-106 13-108
H'0080 122C	CAN0 Message Slot 18 Data 6 (C0MSL18DT6)		CAN0 Message Slot 18 Data 7 (C0MSL18DT7)		13-110 13-112
H'0080 122E	CAN0 Message Slot 18 Timestamp (C0MSL18TSP)				13-114
H'0080 1230	CAN0 Message Slot 19 Standard ID0 (C0MSL19SID0)		CAN0 Message Slot 19 Standard ID1 (C0MSL19SID1)		13-86 13-88

## SFR Area Register Map (24/37)

Address	+0 address		+1 address		See pages
	b0	b7	b8	b15	
H'0080 1232	CAN0 Message Slot 19 Extended ID0 (C0MSL19EID0)		CAN0 Message Slot 19 Extended ID1 (C0MSL19EID1)		13-90 13-92
H'0080 1234	CAN0 Message Slot 19 Extended ID2 (C0MSL19EID2)		CAN0 Message Slot 19 Data Length Register (C0MSL19DLC)		13-94 13-96
H'0080 1236	CAN0 Message Slot 19 Data 0 (C0MSL19DT0)		CAN0 Message Slot 19 Data 1 (C0MSL19DT1)		13-98 13-100
H'0080 1238	CAN0 Message Slot 19 Data 2 (C0MSL19DT2)		CAN0 Message Slot 19 Data 3 (C0MSL19DT3)		13-102 13-104
H'0080 123A	CAN0 Message Slot 19 Data 4 (C0MSL19DT4)		CAN0 Message Slot 19 Data 5 (C0MSL19DT5)		13-106 13-108
H'0080 123C	CAN0 Message Slot 19 Data 6 (C0MSL19DT6)		CAN0 Message Slot 19 Data 7 (C0MSL19DT7)		13-110 13-112
H'0080 123E	CAN0 Message Slot 19 Timestamp (C0MSL19TSP)				13-114
H'0080 1240	CAN0 Message Slot 20 Standard ID0 (C0MSL20SID0)		CAN0 Message Slot 20 Standard ID1 (C0MSL20SID1)		13-86 13-88
H'0080 1242	CAN0 Message Slot 20 Extended ID0 (C0MSL20EID0)		CAN0 Message Slot 20 Extended ID1 (C0MSL20EID1)		13-90 13-92
H'0080 1244	CAN0 Message Slot 20 Extended ID2 (C0MSL20EID2)		CAN0 Message Slot 20 Data Length Register (C0MSL20DLC)		13-94 13-96
H'0080 1246	CAN0 Message Slot 20 Data 0 (C0MSL20DT0)		CAN0 Message Slot 20 Data 1 (C0MSL20DT1)		13-98 13-100
H'0080 1248	CAN0 Message Slot 20 Data 2 (C0MSL20DT2)		CAN0 Message Slot 20 Data 3 (C0MSL20DT3)		13-102 13-104
H'0080 124A	CAN0 Message Slot 20 Data 4 (C0MSL20DT4)		CAN0 Message Slot 20 Data 5 (C0MSL20DT5)		13-106 13-108
H'0080 124C	CAN0 Message Slot 20 Data 6 (C0MSL20DT6)		CAN0 Message Slot 20 Data 7 (C0MSL20DT7)		13-110 13-112
H'0080 124E	CAN0 Message Slot 20 Timestamp (C0MSL20TSP)				13-114
H'0080 1250	CAN0 Message Slot 21 Standard ID0 (C0MSL21SID0)		CAN0 Message Slot 21 Standard ID1 (C0MSL21SID1)		13-86 13-88
H'0080 1252	CAN0 Message Slot 21 Extended ID0 (C0MSL21EID0)		CAN0 Message Slot 21 Extended ID1 (C0MSL21EID1)		13-90 13-92
H'0080 1254	CAN0 Message Slot 21 Extended ID2 (C0MSL21EID2)		CAN0 Message Slot 21 Data Length Register (C0MSL21DLC)		13-94 13-96
H'0080 1256	CAN0 Message Slot 21 Data 0 (C0MSL21DT0)		CAN0 Message Slot 21 Data 1 (C0MSL21DT1)		13-98 13-100
H'0080 1258	CAN0 Message Slot 21 Data 2 (C0MSL21DT2)		CAN0 Message Slot 21 Data 3 (C0MSL21DT3)		13-102 13-104
H'0080 125A	CAN0 Message Slot 21 Data 4 (C0MSL21DT4)		CAN0 Message Slot 21 Data 5 (C0MSL21DT5)		13-106 13-108
H'0080 125C	CAN0 Message Slot 21 Data 6 (C0MSL21DT6)		CAN0 Message Slot 21 Data 7 (C0MSL21DT7)		13-110 13-112
H'0080 125E	CAN0 Message Slot 21 Timestamp (C0MSL21TSP)				13-114
H'0080 1260	CAN0 Message Slot 22 Standard ID0 (C0MSL22SID0)		CAN0 Message Slot 22 Standard ID1 (C0MSL22SID1)		13-86 13-88
H'0080 1262	CAN0 Message Slot 22 Extended ID0 (C0MSL22EID0)		CAN0 Message Slot 22 Extended ID1 (C0MSL22EID1)		13-90 13-92
H'0080 1264	CAN0 Message Slot 22 Extended ID2 (C0MSL22EID2)		CAN0 Message Slot 22 Data Length Register (C0MSL22DLC)		13-94 13-96
H'0080 1266	CAN0 Message Slot 22 Data 0 (C0MSL22DT0)		CAN0 Message Slot 22 Data 1 (C0MSL22DT1)		13-98 13-100
H'0080 1268	CAN0 Message Slot 22 Data 2 (C0MSL22DT2)		CAN0 Message Slot 22 Data 3 (C0MSL22DT3)		13-102 13-104
H'0080 126A	CAN0 Message Slot 22 Data 4 (C0MSL22DT4)		CAN0 Message Slot 22 Data 5 (C0MSL22DT5)		13-106 13-108
H'0080 126C	CAN0 Message Slot 22 Data 6 (C0MSL22DT6)		CAN0 Message Slot 22 Data 7 (C0MSL22DT7)		13-110 13-112
H'0080 126E	CAN0 Message Slot 22 Timestamp (C0MSL22TSP)				13-114
H'0080 1270	CAN0 Message Slot 23 Standard ID0 (C0MSL23SID0)		CAN0 Message Slot 23 Standard ID1 (C0MSL23SID1)		13-86 13-88
H'0080 1272	CAN0 Message Slot 23 Extended ID0 (C0MSL23EID0)		CAN0 Message Slot 23 Extended ID1 (C0MSL23EID1)		13-90 13-92
H'0080 1274	CAN0 Message Slot 23 Extended ID2 (C0MSL23EID2)		CAN0 Message Slot 23 Data Length Register (C0MSL23DLC)		13-94 13-96
H'0080 1276	CAN0 Message Slot 23 Data 0 (C0MSL23DT0)		CAN0 Message Slot 23 Data 1 (C0MSL23DT1)		13-98 13-100

## SFR Area Register Map (25/37)

Address	+0 address		+1 address		See pages
	b0	b7	b8	b15	
H'0080 1280	CAN0 Message Slot 24 Standard ID0 (C0MSL24SID0)		CAN0 Message Slot 24 Standard ID1 (C0MSL24SID1)		13-86 13-88
H'0080 1282	CAN0 Message Slot 24 Extended ID0 (C0MSL24EID0)		CAN0 Message Slot 24 Extended ID1 (C0MSL24EID1)		13-90 13-92
H'0080 1284	CAN0 Message Slot 24 Extended ID2 (C0MSL24EID2)		CAN0 Message Slot 24 Data Length Register (C0MSL24DLC)		13-94 13-96
H'0080 1286	CAN0 Message Slot 24 Data 0 (C0MSL24DT0)		CAN0 Message Slot 24 Data 1 (C0MSL24DT1)		13-98 13-100
H'0080 1288	CAN0 Message Slot 24 Data 2 (C0MSL24DT2)		CAN0 Message Slot 24 Data 3 (C0MSL24DT3)		13-102 13-104
H'0080 128A	CAN0 Message Slot 24 Data 4 (C0MSL24DT4)		CAN0 Message Slot 24 Data 5 (C0MSL24DT5)		13-106 13-108
H'0080 128C	CAN0 Message Slot 24 Data 6 (C0MSL24DT6)		CAN0 Message Slot 24 Data 7 (C0MSL24DT7)		13-110 13-112
H'0080 128E	CAN0 Message Slot 24 Timestamp (C0MSL24TSP)				13-114
H'0080 1290	CAN0 Message Slot 25 Standard ID0 (C0MSL25SID0)		CAN0 Message Slot 25 Standard ID1 (C0MSL25SID1)		13-86 13-88
H'0080 1292	CAN0 Message Slot 25 Extended ID0 (C0MSL25EID0)		CAN0 Message Slot 25 Extended ID1 (C0MSL25EID1)		13-90 13-92
H'0080 1294	CAN0 Message Slot 25 Extended ID2 (C0MSL25EID2)		CAN0 Message Slot 25 Data Length Register (C0MSL25DLC)		13-94 13-96
H'0080 1296	CAN0 Message Slot 25 Data 0 (C0MSL25DT0)		CAN0 Message Slot 25 Data 1 (C0MSL25DT1)		13-98 13-100
H'0080 1298	CAN0 Message Slot 25 Data 2 (C0MSL25DT2)		CAN0 Message Slot 25 Data 3 (C0MSL25DT3)		13-102 13-104
H'0080 129A	CAN0 Message Slot 25 Data 4 (C0MSL25DT4)		CAN0 Message Slot 25 Data 5 (C0MSL25DT5)		13-106 13-108
H'0080 129C	CAN0 Message Slot 25 Data 6 (C0MSL25DT6)		CAN0 Message Slot 25 Data 7 (C0MSL25DT7)		13-110 13-112
H'0080 129E	CAN0 Message Slot 25 Timestamp (C0MSL25TSP)				13-114
H'0080 12A0	CAN0 Message Slot 26 Standard ID0 (C0MSL26SID0)		CAN0 Message Slot 26 Standard ID1 (C0MSL26SID1)		13-86 13-88
H'0080 12A2	CAN0 Message Slot 26 Extended ID0 (C0MSL26EID0)		CAN0 Message Slot 26 Extended ID1 (C0MSL26EID1)		13-90 13-92
H'0080 12A4	CAN0 Message Slot 26 Extended ID2 (C0MSL26EID2)		CAN0 Message Slot 26 Data Length Register (C0MSL26DLC)		13-94 13-96
H'0080 12A6	CAN0 Message Slot 26 Data 0 (C0MSL26DT0)		CAN0 Message Slot 26 Data 1 (C0MSL26DT1)		13-98 13-100
H'0080 12A8	CAN0 Message Slot 26 Data 2 (C0MSL26DT2)		CAN0 Message Slot 26 Data 3 (C0MSL26DT3)		13-102 13-104
H'0080 12AA	CAN0 Message Slot 26 Data 4 (C0MSL26DT4)		CAN0 Message Slot 26 Data 5 (C0MSL26DT5)		13-106 13-108
H'0080 12AC	CAN0 Message Slot 26 Data 6 (C0MSL26DT6)		CAN0 Message Slot 26 Data 7 (C0MSL26DT7)		13-110 13-112
H'0080 12AE	CAN0 Message Slot 26 Timestamp (C0MSL26TSP)				13-114
H'0080 12B0	CAN0 Message Slot 27 Standard ID0 (C0MSL27SID0)		CAN0 Message Slot 27 Standard ID1 (C0MSL27SID1)		13-86 13-88
H'0080 12B2	CAN0 Message Slot 27 Extended ID0 (C0MSL27EID0)		CAN0 Message Slot 27 Extended ID1 (C0MSL27EID1)		13-90 13-92
H'0080 12B4	CAN0 Message Slot 27 Extended ID2 (C0MSL27EID2)		CAN0 Message Slot 27 Data Length Register (C0MSL27DLC)		13-94 13-96
H'0080 12B6	CAN0 Message Slot 27 Data 0 (C0MSL27DT0)		CAN0 Message Slot 27 Data 1 (C0MSL27DT1)		13-98 13-100
H'0080 12B8	CAN0 Message Slot 27 Data 2 (C0MSL27DT2)		CAN0 Message Slot 27 Data 3 (C0MSL27DT3)		13-102 13-104
H'0080 12BA	CAN0 Message Slot 27 Data 4 (C0MSL27DT4)		CAN0 Message Slot 27 Data 5 (C0MSL27DT5)		13-106 13-108
H'0080 12BC	CAN0 Message Slot 27 Data 6 (C0MSL27DT6)		CAN0 Message Slot 27 Data 7 (C0MSL27DT7)		13-110 13-112
H'0080 1278	CAN0 Message Slot 23 Data 2 (C0MSL23DT2)		CAN0 Message Slot 23 Data 3 (C0MSL23DT3)		13-102 13-104
H'0080 127A	CAN0 Message Slot 23 Data 4 (C0MSL23DT4)		CAN0 Message Slot 23 Data 5 (C0MSL23DT5)		13-106 13-108
H'0080 127C	CAN0 Message Slot 23 Data 6 (C0MSL23DT6)		CAN0 Message Slot 23 Data 7 (C0MSL23DT7)		13-110 13-112
H'0080 127E	CAN0 Message Slot 23 Timestamp (C0MSL23TSP)				13-114

## SFR Area Register Map (26/37)

Address	+0 address		+1 address		See pages
	b0	b7	b8	b15	
H'0080 12BE	CAN0 Message Slot 27 Timestamp (C0MSL27TSP)				13-114
H'0080 12C0	CAN0 Message Slot 28 Standard ID0 (C0MSL28SID0)	CAN0 Message Slot 28 Standard ID1 (C0MSL28SID1)			13-86 13-88
H'0080 12C2	CAN0 Message Slot 28 Extended ID0 (C0MSL28EID0)	CAN0 Message Slot 28 Extended ID1 (C0MSL28EID1)			13-90 13-92
H'0080 12C4	CAN0 Message Slot 28 Extended ID2 (C0MSL28EID2)	CAN0 Message Slot 28 Data Length Register (C0MSL28DLC)			13-94 13-96
H'0080 12C6	CAN0 Message Slot 28 Data 0 (C0MSL28DT0)	CAN0 Message Slot 28 Data 1 (C0MSL28DT1)			13-98 13-100
H'0080 12C8	CAN0 Message Slot 28 Data 2 (C0MSL28DT2)	CAN0 Message Slot 28 Data 3 (C0MSL28DT3)			13-102 13-104
H'0080 12CA	CAN0 Message Slot 28 Data 4 (C0MSL28DT4)	CAN0 Message Slot 28 Data 5 (C0MSL28DT5)			13-106 13-108
H'0080 12CC	CAN0 Message Slot 28 Data 6 (C0MSL28DT6)	CAN0 Message Slot 28 Data 7 (C0MSL28DT7)			13-110 13-112
H'0080 12CE	CAN0 Message Slot 28 Timestamp (C0MSL28TSP)				13-114
H'0080 12D0	CAN0 Message Slot 29 Standard ID0 (C0MSL29SID0)	CAN0 Message Slot 29 Standard ID1 (C0MSL29SID1)			13-86 13-88
H'0080 12D2	CAN0 Message Slot 29 Extended ID0 (C0MSL29EID0)	CAN0 Message Slot 29 Extended ID1 (C0MSL29EID1)			13-90 13-92
H'0080 12D4	CAN0 Message Slot 29 Extended ID2 (C0MSL29EID2)	CAN0 Message Slot 29 Data Length Register (C0MSL29DLC)			13-94 13-96
H'0080 12D6	CAN0 Message Slot 29 Data 0 (C0MSL29DT0)	CAN0 Message Slot 29 Data 1 (C0MSL29DT1)			13-98 13-100
H'0080 12D8	CAN0 Message Slot 29 Data 2 (C0MSL29DT2)	CAN0 Message Slot 29 Data 3 (C0MSL29DT3)			13-102 13-104
H'0080 12DA	CAN0 Message Slot 29 Data 4 (C0MSL29DT4)	CAN0 Message Slot 29 Data 5 (C0MSL29DT5)			13-106 13-108
H'0080 12DC	CAN0 Message Slot 29 Data 6 (C0MSL29DT6)	CAN0 Message Slot 29 Data 7 (C0MSL29DT7)			13-110 13-112
H'0080 12DE	CAN0 Message Slot 29 Timestamp (C0MSL29TSP)				13-114
H'0080 12E0	CAN0 Message Slot 30 Standard ID0 (C0MSL30SID0)	CAN0 Message Slot 30 Standard ID1 (C0MSL30SID1)			13-86 13-88
H'0080 12E2	CAN0 Message Slot 30 Extended ID0 (C0MSL30EID0)	CAN0 Message Slot 30 Extended ID1 (C0MSL30EID1)			13-90 13-92
H'0080 12E4	CAN0 Message Slot 30 Extended ID2 (C0MSL30EID2)	CAN0 Message Slot 30 Data Length Register (C0MSL30DLC)			13-94 13-96
H'0080 12E6	CAN0 Message Slot 30 Data 0 (C0MSL30DT0)	CAN0 Message Slot 30 Data 1 (C0MSL30DT1)			13-98 13-100
H'0080 12E8	CAN0 Message Slot 30 Data 2 (C0MSL30DT2)	CAN0 Message Slot 30 Data 3 (C0MSL30DT3)			13-102 13-104
H'0080 12EA	CAN0 Message Slot 30 Data 4 (C0MSL30DT4)	CAN0 Message Slot 30 Data 5 (C0MSL30DT5)			13-106 13-108
H'0080 12EC	CAN0 Message Slot 30 Data 6 (C0MSL30DT6)	CAN0 Message Slot 30 Data 7 (C0MSL30DT7)			13-110 13-112
H'0080 12EE	CAN0 Message Slot 30 Timestamp (C0MSL30TSP)				13-114
H'0080 12F0	CAN0 Message Slot 31 Standard ID0 (C0MSL31SID0)	CAN0 Message Slot 31 Standard ID1 (C0MSL31SID1)			13-86 13-88
H'0080 12F2	CAN0 Message Slot 31 Extended ID0 (C0MSL31EID0)	CAN0 Message Slot 31 Extended ID1 (C0MSL31EID1)			13-90 13-92
H'0080 12F4	CAN0 Message Slot 31 Extended ID2 (C0MSL31EID2)	CAN0 Message Slot 31 Data Length Register (C0MSL31DLC)			13-94 13-96
H'0080 12F6	CAN0 Message Slot 31 Data 0 (C0MSL31DT0)	CAN0 Message Slot 31 Data 1 (C0MSL31DT1)			13-98 13-100
H'0080 12F8	CAN0 Message Slot 31 Data 2 (C0MSL31DT2)	CAN0 Message Slot 31 Data 3 (C0MSL31DT3)			13-102 13-104
H'0080 12FA	CAN0 Message Slot 31 Data 4 (C0MSL31DT4)	CAN0 Message Slot 31 Data 5 (C0MSL31DT5)			13-106 13-108
H'0080 12FC	CAN0 Message Slot 31 Data 6 (C0MSL31DT6)	CAN0 Message Slot 31 Data 7 (C0MSL31DT7)			13-110 13-112
H'0080 12FE	CAN0 Message Slot 31 Timestamp (C0MSL31TSP)				13-114
	(Use inhibited area)				



SFR Area Register Map (27/37)

Address	+0 address		+1 address		See pages
	b0	b7	b8	b15	
H'0080 1400	CAN1 Control Register (CAN1CNT)				13-26
H'0080 1402	CAN1 Status Register (CAN1STAT)				13-29
H'0080 1404	(Use inhibited area)				
H'0080 1406	CAN1 Configuration Register (CAN1CONF)				13-32
H'0080 1408	CAN1 Timestamp Count Register (CAN1TSTMP)				13-35
H'0080 140A	CAN1 Receive Error Count Register (CAN1REC)		CAN1 Transmit Error Count Register (CAN1TEC)		13-36
H'0080 140C	CAN1 Slot Interrupt Request Status Register (CAN1SLISTW) (Upper)				13-40
H'0080 140E	(Lower) (CAN1SLISTL)				
H'0080 1410	CAN1 Slot Interrupt Request Mask Register (CAN1SLIMKW) (Upper)				13-42
H'0080 1412	(Lower) (CAN1SLIMKL)				
H'0080 1414	CAN1 Error Interrupt Request Status Register (CAN1ERIST)		CAN1 Error Interrupt Request Mask Register (CAN1ERIMK)		13-43 13-44
H'0080 1416	CAN1 Baud Rate Prescaler (CAN1BRP)		CAN1 Cause of Error Register (CAN1EF)		13-37 13-67
H'0080 1418	CAN1 Mode Register (CAN1MOD)		CAN1 DMA Transfer Request Select Register (CAN1DMARQ)		13-69 13-70
H'0080 141A	CAN1 Message Slot Number Register (CAN1MSN)		CAN1 Clock Select Register (CAN1CKSEL)		13-71 13-72
H'0080 141C	CAN1 Frame Format Select Register (CAN1FFSW) (Upper)				13-74
H'0080 141E	(Lower) (CAN1FFSL)				
H'0080 1420	CAN1 Global Mask Register A Standard ID0 (C1GMSKAS0)		CAN1 Global Mask Register A Standard ID1 (C1GMSKAS1)		13-76
H'0080 1422	CAN1 Global Mask Register A Extended ID0 (C1GMSKAE0)		CAN1 Global Mask Register A Extended ID1 (C1GMSKAE1)		13-77
H'0080 1424	CAN1 Global Mask Register A Extended ID2 (C1GMSKAE2)		(Use inhibited area)		13-78
H'0080 1426	(Use inhibited area)				
H'0080 1428	CAN1 Global Mask Register B Standard ID0 (C1GMSKBS0)		CAN1 Global Mask Register B Standard ID1 (C1GMSKBS1)		13-76
H'0080 142A	CAN1 Global Mask Register B Extended ID0 (C1GMSKBE0)		CAN1 Global Mask Register B Extended ID1 (C1GMSKBE1)		13-77
H'0080 142C	CAN1 Global Mask Register B Extended ID2 (C1GMSKBE2)		(Use inhibited area)		13-78
H'0080 142E	(Use inhibited area)				
H'0080 1430	CAN1 Local Mask Register A Standard ID0 (C1LMSKAS0)		CAN1 Local Mask Register A Standard ID1 (C1LMSKAS1)		13-76
H'0080 1432	CAN1 Local Mask Register A Extended ID0 (C1LMSKAE0)		CAN1 Local Mask Register A Extended ID1 (C1LMSKAE1)		13-77
H'0080 1434	CAN1 Local Mask Register A Extended ID2 (C1LMSKAE2)		(Use inhibited area)		13-78
H'0080 1436	(Use inhibited area)				
H'0080 1438	CAN1 Local Mask Register B Standard ID0 (C1LMSKBS0)		CAN1 Local Mask Register B Standard ID1 (C1LMSKBS1)		13-76
H'0080 143A	CAN1 Local Mask Register B Extended ID0 (C1LMSKBE0)		CAN1 Local Mask Register B Extended ID1 (C1LMSKBE1)		13-77
H'0080 143C	CAN1 Local Mask Register B Extended ID2 (C1LMSKBE2)		(Use inhibited area)		13-78
H'0080 143E	(Use inhibited area)				
H'0080 1440	CAN1 Single-Shot Mode Control Register (CAN1SSMODEW) (Upper)				13-80
H'0080 1442	(Lower) (CAN1SSMODEL)				

## SFR Area Register Map (28/37)

Address	+0 address		+1 address		See pages
	b0	b7	b8	b15	
H'0080 1444	CAN1 Single-Shot Interrupt Request Status Register (CAN1SSISTW)		(Upper) (CAN1SSIST)		13-45
H'0080 1446			(Lower) (CAN1SSISTL)		
H'0080 1448	CAN1 Single-Shot Interrupt Request Mask Register (CAN1SSIMKW)		(Upper) (CAN1SSIMK)		13-47
H'0080 144A			(Lower) (CAN1SSIMKL)		
	(Use inhibited area)				
H'0080 1450	CAN1 Message Slot 0 Control Register (C1MSLOCNT)		CAN1 Message Slot 1 Control Register (C1MSL1CNT)		13-82
H'0080 1452	CAN1 Message Slot 2 Control Register (C1MSL2CNT)		CAN1 Message Slot 3 Control Register (C1MSL3CNT)		13-82
H'0080 1454	CAN1 Message Slot 4 Control Register (C1MSL4CNT)		CAN1 Message Slot 5 Control Register (C1MSL5CNT)		13-82
H'0080 1456	CAN1 Message Slot 6 Control Register (C1MSL6CNT)		CAN1 Message Slot 7 Control Register (C1MSL7CNT)		13-82
H'0080 1458	CAN1 Message Slot 8 Control Register (C1MSL8CNT)		CAN1 Message Slot 9 Control Register (C1MSL9CNT)		13-82
H'0080 145A	CAN1 Message Slot 10 Control Register (C1MSL10CNT)		CAN1 Message Slot 11 Control Register (C1MSL11CNT)		13-82
H'0080 145C	CAN1 Message Slot 12 Control Register (C1MSL12CNT)		CAN1 Message Slot 13 Control Register (C1MSL13CNT)		13-82
H'0080 145E	CAN1 Message Slot 14 Control Register (C1MSL14CNT)		CAN1 Message Slot 15 Control Register (C1MSL15CNT)		13-82
H'0080 1460	CAN1 Message Slot 16 Control Register (C1MSL16CNT)		CAN1 Message Slot 17 Control Register (C1MSL17CNT)		13-83
H'0080 1462	CAN1 Message Slot 18 Control Register (C1MSL18CNT)		CAN1 Message Slot 19 Control Register (C1MSL19CNT)		13-83
H'0080 1464	CAN1 Message Slot 20 Control Register (C1MSL20CNT)		CAN1 Message Slot 21 Control Register (C1MSL21CNT)		13-83
H'0080 1466	CAN1 Message Slot 22 Control Register (C1MSL22CNT)		CAN1 Message Slot 23 Control Register (C1MSL23CNT)		13-83
H'0080 1468	CAN1 Message Slot 24 Control Register (C1MSL24CNT)		CAN1 Message Slot 25 Control Register (C1MSL25CNT)		13-83
H'0080 146A	CAN1 Message Slot 26 Control Register (C1MSL26CNT)		CAN1 Message Slot 27 Control Register (C1MSL27CNT)		13-83
H'0080 146C	CAN1 Message Slot 28 Control Register (C1MSL28CNT)		CAN1 Message Slot 29 Control Register (C1MSL29CNT)		13-83
H'0080 146E	CAN1 Message Slot 30 Control Register (C1MSL30CNT)		CAN1 Message Slot 31 Control Register (C1MSL31CNT)		13-83
	(Use inhibited area)				
H'0080 1500	CAN1 Message Slot 0 Standard ID0 (C1MSL0SID0)		CAN1 Message Slot 0 Standard ID1 (C1MSL0SID1)		13-86 13-88
H'0080 1502	CAN1 Message Slot 0 Extended ID0 (C1MSL0EID0)		CAN1 Message Slot 0 Extended ID1 (C1MSL0EID1)		13-90 13-92
H'0080 1504	CAN1 Message Slot 0 Extended ID2 (C1MSL0EID2)		CAN1 Message Slot 0 Data Length Register (C1MSL0DLC)		13-94 13-96
H'0080 1506	CAN1 Message Slot 0 Data 0 (C1MSL0DT0)		CAN1 Message Slot 0 Data 1 (C1MSL0DT1)		13-98 13-100
H'0080 1508	CAN1 Message Slot 0 Data 2 (C1MSL0DT2)		CAN1 Message Slot 0 Data 3 (C1MSL0DT3)		13-102 13-104
H'0080 150A	CAN1 Message Slot 0 Data 4 (C1MSL0DT4)		CAN1 Message Slot 0 Data 5 (C1MSL0DT5)		13-106 13-108
H'0080 150C	CAN1 Message Slot 0 Data 6 (C1MSL0DT6)		CAN1 Message Slot 0 Data 7 (C1MSL0DT7)		13-110 13-112
H'0080 150E	CAN1 Message Slot 0 Timestamp (C1MSL0TSP)				13-114
H'0080 1510	CAN1 Message Slot 1 Standard ID0 (C1MSL1SID0)		CAN1 Message Slot 1 Standard ID1 (C1MSL1SID1)		13-86 13-88
H'0080 1512	CAN1 Message Slot 1 Extended ID0 (C1MSL1EID0)		CAN1 Message Slot 1 Extended ID1 (C1MSL1EID1)		13-90 13-92
H'0080 1514	CAN1 Message Slot 1 Extended ID2 (C1MSL1EID2)		CAN1 Message Slot 1 Data Length Register (C1MSL1DLC)		13-94 13-96
H'0080 1516	CAN1 Message Slot 1 Data 0 (C1MSL1DT0)		CAN1 Message Slot 1 Data 1 (C1MSL1DT1)		13-98 13-100
H'0080 1518	CAN1 Message Slot 1 Data 2 (C1MSL1DT2)		CAN1 Message Slot 1 Data 3 (C1MSL1DT3)		13-102 13-104

## SFR Area Register Map (29/37)

Address	+0 address		+1 address		See pages
	b0	b7	b8	b15	
H'0080 151A	CAN1 Message Slot 1 Data 4 (C1MSL1DT4)		CAN1 Message Slot 1 Data 5 (C1MSL1DT5)		13-106 13-108
H'0080 151C	CAN1 Message Slot 1 Data 6 (C1MSL1DT6)		CAN1 Message Slot 1 Data 7 (C1MSL1DT7)		13-110 13-112
H'0080 151E	CAN1 Message Slot 1 Timestamp (C1MSL1TSP)				13-114
H'0080 1520	CAN1 Message Slot 2 Standard ID0 (C1MSL2SID0)		CAN1 Message Slot 2 Standard ID1 (C1MSL2SID1)		13-86 13-88
H'0080 1522	CAN1 Message Slot 2 Extended ID0 (C1MSL2EID0)		CAN1 Message Slot 2 Extended ID1 (C1MSL2EID1)		13-90 13-92
H'0080 1524	CAN1 Message Slot 2 Extended ID2 (C1MSL2EID2)		CAN1 Message Slot 2 Data Length Register (C1MSL2DLC)		13-94 13-96
H'0080 1526	CAN1 Message Slot 2 Data 0 (C1MSL2DT0)		CAN1 Message Slot 2 Data 1 (C1MSL2DT1)		13-98 13-100
H'0080 1528	CAN1 Message Slot 2 Data 2 (C1MSL2DT2)		CAN1 Message Slot 2 Data 3 (C1MSL2DT3)		13-102 13-104
H'0080 152A	CAN1 Message Slot 2 Data 4 (C1MSL2DT4)		CAN1 Message Slot 2 Data 5 (C1MSL2DT5)		13-106 13-108
H'0080 152C	CAN1 Message Slot 2 Data 6 (C1MSL2DT6)		CAN1 Message Slot 2 Data 7 (C1MSL2DT7)		13-110 13-112
H'0080 152E	CAN1 Message Slot 2 Timestamp (C1MSL2TSP)				13-114
H'0080 1530	CAN1 Message Slot 3 Standard ID0 (C1MSL3SID0)		CAN1 Message Slot 3 Standard ID1 (C1MSL3SID1)		13-86 13-88
H'0080 1532	CAN1 Message Slot 3 Extended ID0 (C1MSL3EID0)		CAN1 Message Slot 3 Extended ID1 (C1MSL3EID1)		13-90 13-92
H'0080 1534	CAN1 Message Slot 3 Extended ID2 (C1MSL3EID2)		CAN1 Message Slot 3 Data Length Register (C1MSL3DLC)		13-94 13-96
H'0080 1536	CAN1 Message Slot 3 Data 0 (C1MSL3DT0)		CAN1 Message Slot 3 Data 1 (C1MSL3DT1)		13-98 13-100
H'0080 1538	CAN1 Message Slot 3 Data 2 (C1MSL3DT2)		CAN1 Message Slot 3 Data 3 (C1MSL3DT3)		13-102 13-104
H'0080 153A	CAN1 Message Slot 3 Data 4 (C1MSL3DT4)		CAN1 Message Slot 3 Data 5 (C1MSL3DT5)		13-106 13-108
H'0080 153C	CAN1 Message Slot 3 Data 6 (C1MSL3DT6)		CAN1 Message Slot 3 Data 7 (C1MSL3DT7)		13-110 13-112
H'0080 153E	CAN1 Message Slot 3 Timestamp (C1MSL3TSP)				13-114
H'0080 1540	CAN1 Message Slot 4 Standard ID0 (C1MSL4SID0)		CAN1 Message Slot 4 Standard ID1 (C1MSL4SID1)		13-86 13-88
H'0080 1542	CAN1 Message Slot 4 Extended ID0 (C1MSL4EID0)		CAN1 Message Slot 4 Extended ID1 (C1MSL4EID1)		13-90 13-92
H'0080 1544	CAN1 Message Slot 4 Extended ID2 (C1MSL4EID2)		CAN1 Message Slot 4 Data Length Register (C1MSL4DLC)		13-94 13-96
H'0080 1546	CAN1 Message Slot 4 Data 0 (C1MSL4DT0)		CAN1 Message Slot 4 Data 1 (C1MSL4DT1)		13-98 13-100
H'0080 1548	CAN1 Message Slot 4 Data 2 (C1MSL4DT2)		CAN1 Message Slot 4 Data 3 (C1MSL4DT3)		13-102 13-104
H'0080 154A	CAN1 Message Slot 4 Data 4 (C1MSL4DT4)		CAN1 Message Slot 4 Data 5 (C1MSL4DT5)		13-106 13-108
H'0080 154C	CAN1 Message Slot 4 Data 6 (C1MSL4DT6)		CAN1 Message Slot 4 Data 7 (C1MSL4DT7)		13-110 13-112
H'0080 154E	CAN1 Message Slot 4 Timestamp (C1MSL4TSP)				13-114
H'0080 1550	CAN1 Message Slot 5 Standard ID0 (C1MSL5SID0)		CAN1 Message Slot 5 Standard ID1 (C1MSL5SID1)		13-86 13-88
H'0080 1552	CAN1 Message Slot 5 Extended ID0 (C1MSL5EID0)		CAN1 Message Slot 5 Extended ID1 (C1MSL5EID1)		13-90 13-92
H'0080 1554	CAN1 Message Slot 5 Extended ID2 (C1MSL5EID2)		CAN1 Message Slot 5 Data Length Register (C1MSL5DLC)		13-94 13-96
H'0080 1556	CAN1 Message Slot 5 Data 0 (C1MSL5DT0)		CAN1 Message Slot 5 Data 1 (C1MSL5DT1)		13-98 13-100
H'0080 1558	CAN1 Message Slot 5 Data 2 (C1MSL5DT2)		CAN1 Message Slot 5 Data 3 (C1MSL5DT3)		13-102 13-104
H'0080 155A	CAN1 Message Slot 5 Data 4 (C1MSL5DT4)		CAN1 Message Slot 5 Data 5 (C1MSL5DT5)		13-106 13-108
H'0080 155C	CAN1 Message Slot 5 Data 6 (C1MSL5DT6)		CAN1 Message Slot 5 Data 7 (C1MSL5DT7)		13-110 13-112
H'0080 155E	CAN1 Message Slot 5 Timestamp (C1MSL5TSP)				13-114



## SFR Area Register Map (30/37)

Address	+0 address		+1 address		See pages
	b0	b7	b8	b15	
H'0080 1560	CAN1 Message Slot 6 Standard ID0 (C1MSL6SID0)		CAN1 Message Slot 6 Standard ID1 (C1MSL6SID1)		13-86 13-88
H'0080 1562	CAN1 Message Slot 6 Extended ID0 (C1MSL6EID0)		CAN1 Message Slot 6 Extended ID1 (C1MSL6EID1)		13-90 13-92
H'0080 1564	CAN1 Message Slot 6 Extended ID2 (C1MSL6EID2)		CAN1 Message Slot 6 Data Length Register (C1MSL6DLC)		13-94 13-96
H'0080 1566	CAN1 Message Slot 6 Data 0 (C1MSL6DT0)		CAN1 Message Slot 6 Data 1 (C1MSL6DT1)		13-98 13-100
H'0080 1568	CAN1 Message Slot 6 Data 2 (C1MSL6DT2)		CAN1 Message Slot 6 Data 3 (C1MSL6DT3)		13-102 13-104
H'0080 156A	CAN1 Message Slot 6 Data 4 (C1MSL6DT4)		CAN1 Message Slot 6 Data 5 (C1MSL6DT5)		13-106 13-108
H'0080 156C	CAN1 Message Slot 6 Data 6 (C1MSL6DT6)		CAN1 Message Slot 6 Data 7 (C1MSL6DT7)		13-110 13-112
H'0080 156E	CAN1 Message Slot 6 Timestamp (C1MSL6TSP)				13-114
H'0080 1570	CAN1 Message Slot 7 Standard ID0 (C1MSL7SID0)		CAN1 Message Slot 7 Standard ID1 (C1MSL7SID1)		13-86 13-88
H'0080 1572	CAN1 Message Slot 7 Extended ID0 (C1MSL7EID0)		CAN1 Message Slot 7 Extended ID1 (C1MSL7EID1)		13-90 13-92
H'0080 1574	CAN1 Message Slot 7 Extended ID2 (C1MSL7EID2)		CAN1 Message Slot 7 Data Length Register (C1MSL7DLC)		13-94 13-96
H'0080 1576	CAN1 Message Slot 7 Data 0 (C1MSL7DT0)		CAN1 Message Slot 7 Data 1 (C1MSL7DT1)		13-98 13-100
H'0080 1578	CAN1 Message Slot 7 Data 2 (C1MSL7DT2)		CAN1 Message Slot 7 Data 3 (C1MSL7DT3)		13-102 13-104
H'0080 157A	CAN1 Message Slot 7 Data 4 (C1MSL7DT4)		CAN1 Message Slot 7 Data 5 (C1MSL7DT5)		13-106 13-108
H'0080 157C	CAN1 Message Slot 7 Data 6 (C1MSL7DT6)		CAN1 Message Slot 7 Data 7 (C1MSL7DT7)		13-110 13-112
H'0080 157E	CAN1 Message Slot 7 Timestamp (C1MSL7TSP)				13-114
H'0080 1580	CAN1 Message Slot 8 Standard ID0 (C1MSL8SID0)		CAN1 Message Slot 8 Standard ID1 (C1MSL8SID1)		13-86 13-88
H'0080 1582	CAN1 Message Slot 8 Extended ID0 (C1MSL8EID0)		CAN1 Message Slot 8 Extended ID1 (C1MSL8EID1)		13-90 13-92
H'0080 1584	CAN1 Message Slot 8 Extended ID2 (C1MSL8EID2)		CAN1 Message Slot 8 Data Length Register (C1MSL8DLC)		13-94 13-96
H'0080 1586	CAN1 Message Slot 8 Data 0 (C1MSL8DT0)		CAN1 Message Slot 8 Data 1 (C1MSL8DT1)		13-98 13-100
H'0080 1588	CAN1 Message Slot 8 Data 2 (C1MSL8DT2)		CAN1 Message Slot 8 Data 3 (C1MSL8DT3)		13-102 13-104
H'0080 158A	CAN1 Message Slot 8 Data 4 (C1MSL8DT4)		CAN1 Message Slot 8 Data 5 (C1MSL8DT5)		13-106 13-108
H'0080 158C	CAN1 Message Slot 8 Data 6 (C1MSL8DT6)		CAN1 Message Slot 8 Data 7 (C1MSL8DT7)		13-110 13-112
H'0080 158E	CAN1 Message Slot 8 Timestamp (C1MSL8TSP)				13-114
H'0080 1590	CAN1 Message Slot 9 Standard ID0 (C1MSL9SID0)		CAN1 Message Slot 9 Standard ID1 (C1MSL9SID1)		13-86 13-88
H'0080 1592	CAN1 Message Slot 9 Extended ID0 (C1MSL9EID0)		CAN1 Message Slot 9 Extended ID1 (C1MSL9EID1)		13-90 13-92
H'0080 1594	CAN1 Message Slot 9 Extended ID2 (C1MSL9EID2)		CAN1 Message Slot 9 Data Length Register (C1MSL9DLC)		13-94 13-96
H'0080 1596	CAN1 Message Slot 9 Data 0 (C1MSL9DT0)		CAN1 Message Slot 9 Data 1 (C1MSL9DT1)		13-98 13-100
H'0080 1598	CAN1 Message Slot 9 Data 2 (C1MSL9DT2)		CAN1 Message Slot 9 Data 3 (C1MSL9DT3)		13-102 13-104
H'0080 159A	CAN1 Message Slot 9 Data 4 (C1MSL9DT4)		CAN1 Message Slot 9 Data 5 (C1MSL9DT5)		13-106 13-108
H'0080 159C	CAN1 Message Slot 9 Data 6 (C1MSL9DT6)		CAN1 Message Slot 9 Data 7 (C1MSL9DT7)		13-110 13-112
H'0080 159E	CAN1 Message Slot 9 Timestamp (C1MSL9TSP)				13-114
H'0080 15A0	CAN1 Message Slot 10 Standard ID0 (C1MSL10SID0)		CAN1 Message Slot 10 Standard ID1 (C1MSL10SID1)		13-86 13-88
H'0080 15A2	CAN1 Message Slot 10 Extended ID0 (C1MSL10EID0)		CAN1 Message Slot 10 Extended ID1 (C1MSL10EID1)		13-90 13-92
H'0080 15A4	CAN1 Message Slot 10 Extended ID2 (C1MSL10EID2)		CAN1 Message Slot 10 Data Length Register (C1MSL10DLC)		13-94 13-96

## SFR Area Register Map (31/37)

Address	+0 address		+1 address		See pages
	b0	b7	b8	b15	
H'0080 15A6	CAN1 Message Slot 10 Data 0 (C1MSL10DT0)		CAN1 Message Slot 10 Data 1 (C1MSL10DT1)		13-98 13-100
H'0080 15A8	CAN1 Message Slot 10 Data 2 (C1MSL10DT2)		CAN1 Message Slot 10 Data 3 (C1MSL10DT3)		13-102 13-104
H'0080 15AA	CAN1 Message Slot 10 Data 4 (C1MSL10DT4)		CAN1 Message Slot 10 Data 5 (C1MSL10DT5)		13-106 13-108
H'0080 15AC	CAN1 Message Slot 10 Data 6 (C1MSL10DT6)		CAN1 Message Slot 10 Data 7 (C1MSL10DT7)		13-110 13-112
H'0080 15AE	CAN1 Message Slot 10 Timestamp (C1MSL10TSP)				13-114
H'0080 15B0	CAN1 Message Slot 11 Standard ID0 (C1MSL11SID0)		CAN1 Message Slot 11 Standard ID1 (C1MSL11SID1)		13-86 13-88
H'0080 15B2	CAN1 Message Slot 11 Extended ID0 (C1MSL11EID0)		CAN1 Message Slot 11 Extended ID1 (C1MSL11EID1)		13-90 13-92
H'0080 15B4	CAN1 Message Slot 11 Extended ID2 (C1MSL11EID2)		CAN1 Message Slot 11 Data Length Register (C1MSL11DLC)		13-94 13-96
H'0080 15B6	CAN1 Message Slot 11 Data 0 (C1MSL11DT0)		CAN1 Message Slot 11 Data 1 (C1MSL11DT1)		13-98 13-100
H'0080 15B8	CAN1 Message Slot 11 Data 2 (C1MSL11DT2)		CAN1 Message Slot 11 Data 3 (C1MSL11DT3)		13-102 13-104
H'0080 15BA	CAN1 Message Slot 11 Data 4 (C1MSL11DT4)		CAN1 Message Slot 11 Data 5 (C1MSL11DT5)		13-106 13-108
H'0080 15BC	CAN1 Message Slot 11 Data 6 (C1MSL11DT6)		CAN1 Message Slot 11 Data 7 (C1MSL11DT7)		13-110 13-112
H'0080 15BE	CAN1 Message Slot 11 Timestamp (C1MSL11TSP)				13-114
H'0080 15C0	CAN1 Message Slot 12 Standard ID0 (C1MSL12SID0)		CAN1 Message Slot 12 Standard ID1 (C1MSL12SID1)		13-86 13-88
H'0080 15C2	CAN1 Message Slot 12 Extended ID0 (C1MSL12EID0)		CAN1 Message Slot 12 Extended ID1 (C1MSL12EID1)		13-90 13-92
H'0080 15C4	CAN1 Message Slot 12 Extended ID2 (C1MSL12EID2)		CAN1 Message Slot 12 Data Length Register (C1MSL12DLC)		13-94 13-96
H'0080 15C6	CAN1 Message Slot 12 Data 0 (C1MSL12DT0)		CAN1 Message Slot 12 Data 1 (C1MSL12DT1)		13-98 13-100
H'0080 15C8	CAN1 Message Slot 12 Data 2 (C1MSL12DT2)		CAN1 Message Slot 12 Data 3 (C1MSL12DT3)		13-102 13-104
H'0080 15CA	CAN1 Message Slot 12 Data 4 (C1MSL12DT4)		CAN1 Message Slot 12 Data 5 (C1MSL12DT5)		13-106 13-108
H'0080 15CC	CAN1 Message Slot 12 Data 6 (C1MSL12DT6)		CAN1 Message Slot 12 Data 7 (C1MSL12DT7)		13-110 13-112
H'0080 15CE	CAN1 Message Slot 12 Timestamp (C1MSL12TSP)				13-114
H'0080 15D0	CAN1 Message Slot 13 Standard ID0 (C1MSL13SID0)		CAN1 Message Slot 13 Standard ID1 (C1MSL13SID1)		13-86 13-88
H'0080 15D2	CAN1 Message Slot 13 Extended ID0 (C1MSL13EID0)		CAN1 Message Slot 13 Extended ID1 (C1MSL13EID1)		13-90 13-92
H'0080 15D4	CAN1 Message Slot 13 Extended ID2 (C1MSL13EID2)		CAN1 Message Slot 13 Data Length Register (C1MSL13DLC)		13-94 13-96
H'0080 15D6	CAN1 Message Slot 13 Data 0 (C1MSL13DT0)		CAN1 Message Slot 13 Data 1 (C1MSL13DT1)		13-98 13-100
H'0080 15D8	CAN1 Message Slot 13 Data 2 (C1MSL13DT2)		CAN1 Message Slot 13 Data 3 (C1MSL13DT3)		13-102 13-104
H'0080 15DA	CAN1 Message Slot 13 Data 4 (C1MSL13DT4)		CAN1 Message Slot 13 Data 5 (C1MSL13DT5)		13-106 13-108
H'0080 15DC	CAN1 Message Slot 13 Data 6 (C1MSL13DT6)		CAN1 Message Slot 13 Data 7 (C1MSL13DT7)		13-110 13-112
H'0080 15DE	CAN1 Message Slot 13 Timestamp (C1MSL13TSP)				13-114
H'0080 15E0	CAN1 Message Slot 14 Standard ID0 (C1MSL14SID0)		CAN1 Message Slot 14 Standard ID1 (C1MSL14SID1)		13-86 13-88
H'0080 15E2	CAN1 Message Slot 14 Extended ID0 (C1MSL14EID0)		CAN1 Message Slot 14 Extended ID1 (C1MSL14EID1)		13-90 13-92
H'0080 15E4	CAN1 Message Slot 14 Extended ID2 (C1MSL14EID2)		CAN1 Message Slot 14 Data Length Register (C1MSL14DLC)		13-94 13-96
H'0080 15E6	CAN1 Message Slot 14 Data 0 (C1MSL14DT0)		CAN1 Message Slot 14 Data 1 (C1MSL14DT1)		13-98 13-100
H'0080 15E8	CAN1 Message Slot 14 Data 2 (C1MSL14DT2)		CAN1 Message Slot 14 Data 3 (C1MSL14DT3)		13-102 13-104
H'0080 15EA	CAN1 Message Slot 14 Data 4 (C1MSL14DT4)		CAN1 Message Slot 14 Data 5 (C1MSL14DT5)		13-106 13-108

SFR Area Register Map (32/37)

Address	+0 address		+1 address		See pages
	b0	b7	b8	b15	
H'0080 15EC	CAN1 Message Slot 14 Data 6 (C1MSL14DT6)		CAN1 Message Slot 14 Data 7 (C1MSL14DT7)		13-110 13-112
H'0080 15EE	CAN1 Message Slot 14 Timestamp (C1MSL14TSP)				13-114
H'0080 15F0	CAN1 Message Slot 15 Standard ID0 (C1MSL15SID0)		CAN1 Message Slot 15 Standard ID1 (C1MSL15SID1)		13-86 13-88
H'0080 15F2	CAN1 Message Slot 15 Extended ID0 (C1MSL15EID0)		CAN1 Message Slot 15 Extended ID1 (C1MSL15EID1)		13-90 13-92
H'0080 15F4	CAN1 Message Slot 15 Extended ID2 (C1MSL15EID2)		CAN1 Message Slot 15 Data Length Register (C1MSL15DLC)		13-94 13-96
H'0080 15F6	CAN1 Message Slot 15 Data 0 (C1MSL15DT0)		CAN1 Message Slot 15 Data 1 (C1MSL15DT1)		13-98 13-100
H'0080 15F8	CAN1 Message Slot 15 Data 2 (C1MSL15DT2)		CAN1 Message Slot 15 Data 3 (C1MSL15DT3)		13-102 13-104
H'0080 15FA	CAN1 Message Slot 15 Data 4 (C1MSL15DT4)		CAN1 Message Slot 15 Data 5 (C1MSL15DT5)		13-106 13-108
H'0080 15FC	CAN1 Message Slot 15 Data 6 (C1MSL15DT6)		CAN1 Message Slot 15 Data 7 (C1MSL15DT7)		13-110 13-112
H'0080 15FE	CAN1 Message Slot 15 Timestamp (C1MSL15TSP)				13-114
H'0080 1600	CAN1 Message Slot 16 Standard ID0 (C1MSL16SID0)		CAN1 Message Slot 16 Standard ID1 (C1MSL16SID1)		13-87 13-89
H'0080 1602	CAN1 Message Slot 16 Extended ID0 (C1MSL16EID0)		CAN1 Message Slot 16 Extended ID1 (C1MSL16EID1)		13-91 13-93
H'0080 1604	CAN1 Message Slot 16 Extended ID2 (C1MSL16EID2)		CAN1 Message Slot 16 Data Length Register (C1MSL16DLC)		13-95 13-97
H'0080 1606	CAN1 Message Slot 16 Data 0 (C1MSL16DT0)		CAN1 Message Slot 16 Data 1 (C1MSL16DT1)		13-99 13-101
H'0080 1608	CAN1 Message Slot 16 Data 2 (C1MSL16DT2)		CAN1 Message Slot 16 Data 3 (C1MSL16DT3)		13-103 13-105
H'0080 160A	CAN1 Message Slot 16 Data 4 (C1MSL16DT4)		CAN1 Message Slot 16 Data 5 (C1MSL16DT5)		13-107 13-109
H'0080 160C	CAN1 Message Slot 16 Data 6 (C1MSL16DT6)		CAN1 Message Slot 16 Data 7 (C1MSL16DT7)		13-111 13-113
H'0080 160E	CAN1 Message Slot 16 Timestamp (C1MSL16TSP)				13-115
H'0080 1610	CAN1 Message Slot 17 Standard ID0 (C1MSL17SID0)		CAN1 Message Slot 17 Standard ID1 (C1MSL17SID1)		13-87 13-89
H'0080 1612	CAN1 Message Slot 17 Extended ID0 (C1MSL17EID0)		CAN1 Message Slot 17 Extended ID1 (C1MSL17EID1)		13-91 13-93
H'0080 1614	CAN1 Message Slot 17 Extended ID2 (C1MSL17EID2)		CAN1 Message Slot 17 Data Length Register (C1MSL17DLC)		13-95 13-97
H'0080 1616	CAN1 Message Slot 17 Data 0 (C1MSL17DT0)		CAN1 Message Slot 17 Data 1 (C1MSL17DT1)		13-99 13-101
H'0080 1618	CAN1 Message Slot 17 Data 2 (C1MSL17DT2)		CAN1 Message Slot 17 Data 3 (C1MSL17DT3)		13-103 13-105
H'0080 161A	CAN1 Message Slot 17 Data 4 (C1MSL17DT4)		CAN1 Message Slot 17 Data 5 (C1MSL17DT5)		13-107 13-109
H'0080 161C	CAN1 Message Slot 17 Data 6 (C1MSL17DT6)		CAN1 Message Slot 17 Data 7 (C1MSL17DT7)		13-111 13-113
H'0080 161E	CAN1 Message Slot 17 Timestamp (C1MSL17TSP)				13-115
H'0080 1620	CAN1 Message Slot 18 Standard ID0 (C1MSL18SID0)		CAN1 Message Slot 18 Standard ID1 (C1MSL18SID1)		13-87 13-89
H'0080 1622	CAN1 Message Slot 18 Extended ID0 (C1MSL18EID0)		CAN1 Message Slot 18 Extended ID1 (C1MSL18EID1)		13-91 13-93
H'0080 1624	CAN1 Message Slot 18 Extended ID2 (C1MSL18EID2)		CAN1 Message Slot 18 Data Length Register (C1MSL18DLC)		13-95 13-97
H'0080 1626	CAN1 Message Slot 18 Data 0 (C1MSL18DT0)		CAN1 Message Slot 18 Data 1 (C1MSL18DT1)		13-99 13-101
H'0080 1628	CAN1 Message Slot 18 Data 2 (C1MSL18DT2)		CAN1 Message Slot 18 Data 3 (C1MSL18DT3)		13-103 13-105
H'0080 162A	CAN1 Message Slot 18 Data 4 (C1MSL18DT4)		CAN1 Message Slot 18 Data 5 (C1MSL18DT5)		13-107 13-109
H'0080 162C	CAN1 Message Slot 18 Data 6 (C1MSL18DT6)		CAN1 Message Slot 18 Data 7 (C1MSL18DT7)		13-111 13-113
H'0080 162E	CAN1 Message Slot 18 Timestamp (C1MSL18TSP)				13-115
H'0080 1630	CAN1 Message Slot 19 Standard ID0 (C1MSL19SID0)		CAN1 Message Slot 19 Standard ID1 (C1MSL19SID1)		13-87 13-89

## SFR Area Register Map (33/37)

Address	+0 address		+1 address		See pages
	b0	b7	b8	b15	
H'0080 1632	CAN1 Message Slot 19 Extended ID0 (C1MSL19EID0)		CAN1 Message Slot 19 Extended ID1 (C1MSL19EID1)		13-91 13-93
H'0080 1634	CAN1 Message Slot 19 Extended ID2 (C1MSL19EID2)		CAN1 Message Slot 19 Data Length Register (C1MSL19DLC)		13-95 13-97
H'0080 1636	CAN1 Message Slot 19 Data 0 (C1MSL19DT0)		CAN1 Message Slot 19 Data 1 (C1MSL19DT1)		13-99 13-101
H'0080 1638	CAN1 Message Slot 19 Data 2 (C1MSL19DT2)		CAN1 Message Slot 19 Data 3 (C1MSL19DT3)		13-103 13-105
H'0080 163A	CAN1 Message Slot 19 Data 4 (C1MSL19DT4)		CAN1 Message Slot 19 Data 5 (C1MSL19DT5)		13-107 13-109
H'0080 163C	CAN1 Message Slot 19 Data 6 (C1MSL19DT6)		CAN1 Message Slot 19 Data 7 (C1MSL19DT7)		13-111 13-113
H'0080 163E	CAN1 Message Slot 19 Timestamp (C1MSL19TSP)				13-115
H'0080 1640	CAN1 Message Slot 20 Standard ID0 (C1MSL20SID0)		CAN1 Message Slot 20 Standard ID1 (C1MSL20SID1)		13-87 13-89
H'0080 1642	CAN1 Message Slot 20 Extended ID0 (C1MSL20EID0)		CAN1 Message Slot 20 Extended ID1 (C1MSL20EID1)		13-91 13-93
H'0080 1644	CAN1 Message Slot 20 Extended ID2 (C1MSL20EID2)		CAN1 Message Slot 20 Data Length Register (C1MSL20DLC)		13-95 13-97
H'0080 1646	CAN1 Message Slot 20 Data 0 (C1MSL20DT0)		CAN1 Message Slot 20 Data 1 (C1MSL20DT1)		13-99 13-101
H'0080 1648	CAN1 Message Slot 20 Data 2 (C1MSL20DT2)		CAN1 Message Slot 20 Data 3 (C1MSL20DT3)		13-103 13-105
H'0080 164A	CAN1 Message Slot 20 Data 4 (C1MSL20DT4)		CAN1 Message Slot 20 Data 5 (C1MSL20DT5)		13-107 13-109
H'0080 164C	CAN1 Message Slot 20 Data 6 (C1MSL20DT6)		CAN1 Message Slot 20 Data 7 (C1MSL20DT7)		13-111 13-113
H'0080 164E	CAN1 Message Slot 20 Timestamp (C1MSL20TSP)				13-115
H'0080 1650	CAN1 Message Slot 21 Standard ID0 (C1MSL21SID0)		CAN1 Message Slot 21 Standard ID1 (C1MSL21SID1)		13-87 13-89
H'0080 1652	CAN1 Message Slot 21 Extended ID0 (C1MSL21EID0)		CAN1 Message Slot 21 Extended ID1 (C1MSL21EID1)		13-91 13-93
H'0080 1654	CAN1 Message Slot 21 Extended ID2 (C1MSL21EID2)		CAN1 Message Slot 21 Data Length Register (C1MSL21DLC)		13-95 13-97
H'0080 1656	CAN1 Message Slot 21 Data 0 (C1MSL21DT0)		CAN1 Message Slot 21 Data 1 (C1MSL21DT1)		13-99 13-101
H'0080 1658	CAN1 Message Slot 21 Data 2 (C1MSL21DT2)		CAN1 Message Slot 21 Data 3 (C1MSL21DT3)		13-103 13-105
H'0080 165A	CAN1 Message Slot 21 Data 4 (C1MSL21DT4)		CAN1 Message Slot 21 Data 5 (C1MSL21DT5)		13-107 13-109
H'0080 165C	CAN1 Message Slot 21 Data 6 (C1MSL21DT6)		CAN1 Message Slot 21 Data 7 (C1MSL21DT7)		13-111 13-113
H'0080 165E	CAN1 Message Slot 21 Timestamp (C1MSL21TSP)				13-115
H'0080 1660	CAN1 Message Slot 22 Standard ID0 (C1MSL22SID0)		CAN1 Message Slot 22 Standard ID1 (C1MSL22SID1)		13-87 13-89
H'0080 1662	CAN1 Message Slot 22 Extended ID0 (C1MSL22EID0)		CAN1 Message Slot 22 Extended ID1 (C1MSL22EID1)		13-91 13-93
H'0080 1664	CAN1 Message Slot 22 Extended ID2 (C1MSL22EID2)		CAN1 Message Slot 22 Data Length Register (C1MSL22DLC)		13-95 13-97
H'0080 1666	CAN1 Message Slot 22 Data 0 (C1MSL22DT0)		CAN1 Message Slot 22 Data 1 (C1MSL22DT1)		13-99 13-101
H'0080 1668	CAN1 Message Slot 22 Data 2 (C1MSL22DT2)		CAN1 Message Slot 22 Data 3 (C1MSL22DT3)		13-103 13-105
H'0080 166A	CAN1 Message Slot 22 Data 4 (C1MSL22DT4)		CAN1 Message Slot 22 Data 5 (C1MSL22DT5)		13-107 13-109
H'0080 166C	CAN1 Message Slot 22 Data 6 (C1MSL22DT6)		CAN1 Message Slot 22 Data 7 (C1MSL22DT7)		13-111 13-113
H'0080 166E	CAN1 Message Slot 22 Timestamp (C1MSL22TSP)				13-115
H'0080 1670	CAN1 Message Slot 23 Standard ID0 (C1MSL23SID0)		CAN1 Message Slot 23 Standard ID1 (C1MSL23SID1)		13-87 13-89
H'0080 1672	CAN1 Message Slot 23 Extended ID0 (C1MSL23EID0)		CAN1 Message Slot 23 Extended ID1 (C1MSL23EID1)		13-91 13-93
H'0080 1674	CAN1 Message Slot 23 Extended ID2 (C1MSL23EID2)		CAN1 Message Slot 23 Data Length Register (C1MSL23DLC)		13-95 13-97
H'0080 1676	CAN1 Message Slot 23 Data 0 (C1MSL23DT0)		CAN1 Message Slot 23 Data 1 (C1MSL23DT1)		13-99 13-101

## SFR Area Register Map (34/37)

Address	+0 address		+1 address		See pages
	b0	b7	b8	b15	
H'0080 1678	CAN1 Message Slot 23 Data 2 (C1MSL23DT2)		CAN1 Message Slot 23 Data 3 (C1MSL23DT3)		13-103 13-105
H'0080 167A	CAN1 Message Slot 23 Data 4 (C1MSL23DT4)		CAN1 Message Slot 23 Data 5 (C1MSL23DT5)		13-107 13-109
H'0080 167C	CAN1 Message Slot 23 Data 6 (C1MSL23DT6)		CAN1 Message Slot 23 Data 7 (C1MSL23DT7)		13-111 13-113
H'0080 167E	CAN1 Message Slot 23 Timestamp (C1MSL23TSP)				13-115
H'0080 1680	CAN1 Message Slot 24 Standard ID0 (C1MSL24SID0)		CAN1 Message Slot 24 Standard ID1 (C1MSL24SID1)		13-87 13-89
H'0080 1682	CAN1 Message Slot 24 Extended ID0 (C1MSL24EID0)		CAN1 Message Slot 24 Extended ID1 (C1MSL24EID1)		13-91 13-93
H'0080 1684	CAN1 Message Slot 24 Extended ID2 (C1MSL24EID2)		CAN1 Message Slot 24 Data Length Register (C1MSL24DLC)		13-95 13-97
H'0080 1686	CAN1 Message Slot 24 Data 0 (C1MSL24DT0)		CAN1 Message Slot 24 Data 1 (C1MSL24DT1)		13-99 13-101
H'0080 1688	CAN1 Message Slot 24 Data 2 (C1MSL24DT2)		CAN1 Message Slot 24 Data 3 (C1MSL24DT3)		13-103 13-105
H'0080 168A	CAN1 Message Slot 24 Data 4 (C1MSL24DT4)		CAN1 Message Slot 24 Data 5 (C1MSL24DT5)		13-107 13-109
H'0080 168C	CAN1 Message Slot 24 Data 6 (C1MSL24DT6)		CAN1 Message Slot 24 Data 7 (C1MSL24DT7)		13-111 13-113
H'0080 168E	CAN1 Message Slot 24 Timestamp (C1MSL24TSP)				13-115
H'0080 1690	CAN1 Message Slot 25 Standard ID0 (C1MSL25SID0)		CAN1 Message Slot 25 Standard ID1 (C1MSL25SID1)		13-87 13-89
H'0080 1692	CAN1 Message Slot 25 Extended ID0 (C1MSL25EID0)		CAN1 Message Slot 25 Extended ID1 (C1MSL25EID1)		13-91 13-93
H'0080 1694	CAN1 Message Slot 25 Extended ID2 (C1MSL25EID2)		CAN1 Message Slot 25 Data Length Register (C1MSL25DLC)		13-95 13-97
H'0080 1696	CAN1 Message Slot 25 Data 0 (C1MSL25DT0)		CAN1 Message Slot 25 Data 1 (C1MSL25DT1)		13-99 13-101
H'0080 1698	CAN1 Message Slot 25 Data 2 (C1MSL25DT2)		CAN1 Message Slot 25 Data 3 (C1MSL25DT3)		13-103 13-105
H'0080 169A	CAN1 Message Slot 25 Data 4 (C1MSL25DT4)		CAN1 Message Slot 25 Data 5 (C1MSL25DT5)		13-107 13-109
H'0080 169C	CAN1 Message Slot 25 Data 6 (C1MSL25DT6)		CAN1 Message Slot 25 Data 7 (C1MSL25DT7)		13-111 13-113
H'0080 169E	CAN1 Message Slot 25 Timestamp (C1MSL25TSP)				13-115
H'0080 16A0	CAN1 Message Slot 26 Standard ID0 (C1MSL26SID0)		CAN1 Message Slot 26 Standard ID1 (C1MSL26SID1)		13-87 13-89
H'0080 16A2	CAN1 Message Slot 26 Extended ID0 (C1MSL26EID0)		CAN1 Message Slot 26 Extended ID1 (C1MSL26EID1)		13-91 13-93
H'0080 16A4	CAN1 Message Slot 26 Extended ID2 (C1MSL26EID2)		CAN1 Message Slot 26 Data Length Register (C1MSL26DLC)		13-95 13-97
H'0080 16A6	CAN1 Message Slot 26 Data 0 (C1MSL26DT0)		CAN1 Message Slot 26 Data 1 (C1MSL26DT1)		13-99 13-101
H'0080 16A8	CAN1 Message Slot 26 Data 2 (C1MSL26DT2)		CAN1 Message Slot 26 Data 3 (C1MSL26DT3)		13-103 13-105
H'0080 16AA	CAN1 Message Slot 26 Data 4 (C1MSL26DT4)		CAN1 Message Slot 26 Data 5 (C1MSL26DT5)		13-107 13-109
H'0080 16AC	CAN1 Message Slot 26 Data 6 (C1MSL26DT6)		CAN1 Message Slot 26 Data 7 (C1MSL26DT7)		13-111 13-113
H'0080 16AE	CAN1 Message Slot 26 Timestamp (C1MSL26TSP)				13-115
H'0080 16B0	CAN1 Message Slot 27 Standard ID0 (C1MSL27SID0)		CAN1 Message Slot 27 Standard ID1 (C1MSL27SID1)		13-87 13-89
H'0080 16B2	CAN1 Message Slot 27 Extended ID0 (C1MSL27EID0)		CAN1 Message Slot 27 Extended ID1 (C1MSL27EID1)		13-91 13-93
H'0080 16B4	CAN1 Message Slot 27 Extended ID2 (C1MSL27EID2)		CAN1 Message Slot 27 Data Length Register (C1MSL27DLC)		13-95 13-97
H'0080 16B6	CAN1 Message Slot 27 Data 0 (C1MSL27DT0)		CAN1 Message Slot 27 Data 1 (C1MSL27DT1)		13-99 13-101
H'0080 16B8	CAN1 Message Slot 27 Data 2 (C1MSL27DT2)		CAN1 Message Slot 27 Data 3 (C1MSL27DT3)		13-103 13-105
H'0080 16BA	CAN1 Message Slot 27 Data 4 (C1MSL27DT4)		CAN1 Message Slot 27 Data 5 (C1MSL27DT5)		13-107 13-109
H'0080 16BC	CAN1 Message Slot 27 Data 6 (C1MSL27DT6)		CAN1 Message Slot 27 Data 7 (C1MSL27DT7)		13-111 13-113



## SFR Area Register Map (35/37)

Address	+0 address		+1 address		See pages
	b0	b7	b8	b15	
H'0080 16BE	CAN1 Message Slot 27 Timestamp (C1MSL27TSP)				13-115
H'0080 16C0	CAN1 Message Slot 28 Standard ID0 (C1MSL28SID0)	CAN1 Message Slot 28 Standard ID1 (C1MSL28SID1)			13-87 13-89
H'0080 16C2	CAN1 Message Slot 28 Extended ID0 (C1MSL28EID0)	CAN1 Message Slot 28 Extended ID1 (C1MSL28EID1)			13-91 13-93
H'0080 16C4	CAN1 Message Slot 28 Extended ID2 (C1MSL28EID2)	CAN1 Message Slot 28 Data Length Register (C1MSL28DLC)			13-95 13-97
H'0080 16C6	CAN1 Message Slot 28 Data 0 (C1MSL28DT0)	CAN1 Message Slot 28 Data 1 (C1MSL28DT1)			13-99 13-101
H'0080 16C8	CAN1 Message Slot 28 Data 2 (C1MSL28DT2)	CAN1 Message Slot 28 Data 3 (C1MSL28DT3)			13-103 13-105
H'0080 16CA	CAN1 Message Slot 28 Data 4 (C1MSL28DT4)	CAN1 Message Slot 28 Data 5 (C1MSL28DT5)			13-107 13-109
H'0080 16CC	CAN1 Message Slot 28 Data 6 (C1MSL28DT6)	CAN1 Message Slot 28 Data 7 (C1MSL28DT7)			13-111 13-113
H'0080 16CE	CAN1 Message Slot 28 Timestamp (C1MSL28TSP)				13-115
H'0080 16D0	CAN1 Message Slot 29 Standard ID0 (C1MSL29SID0)	CAN1 Message Slot 29 Standard ID1 (C1MSL29SID1)			13-87 13-89
H'0080 16D2	CAN1 Message Slot 29 Extended ID0 (C1MSL29EID0)	CAN1 Message Slot 29 Extended ID1 (C1MSL29EID1)			13-91 13-93
H'0080 16D4	CAN1 Message Slot 29 Extended ID2 (C1MSL29EID2)	CAN1 Message Slot 29 Data Length Register (C1MSL29DLC)			13-95 13-97
H'0080 16D6	CAN1 Message Slot 29 Data 0 (C1MSL29DT0)	CAN1 Message Slot 29 Data 1 (C1MSL29DT1)			13-99 13-101
H'0080 16D8	CAN1 Message Slot 29 Data 2 (C1MSL29DT2)	CAN1 Message Slot 29 Data 3 (C1MSL29DT3)			13-103 13-105
H'0080 16DA	CAN1 Message Slot 29 Data 4 (C1MSL29DT4)	CAN1 Message Slot 29 Data 5 (C1MSL29DT5)			13-107 13-109
H'0080 16DC	CAN1 Message Slot 29 Data 6 (C1MSL29DT6)	CAN1 Message Slot 29 Data 7 (C1MSL29DT7)			13-111 13-113
H'0080 16DE	CAN1 Message Slot 29 Timestamp (C1MSL29TSP)				13-115
H'0080 16E0	CAN1 Message Slot 30 Standard ID0 (C1MSL30SID0)	CAN1 Message Slot 30 Standard ID1 (C1MSL30SID1)			13-87 13-89
H'0080 16E2	CAN1 Message Slot 30 Extended ID0 (C1MSL30EID0)	CAN1 Message Slot 30 Extended ID1 (C1MSL30EID1)			13-91 13-93
H'0080 16E4	CAN1 Message Slot 30 Extended ID2 (C1MSL30EID2)	CAN1 Message Slot 30 Data Length Register (C1MSL30DLC)			13-95 13-97
H'0080 16E6	CAN1 Message Slot 30 Data 0 (C1MSL30DT0)	CAN1 Message Slot 30 Data 1 (C1MSL30DT1)			13-99 13-101
H'0080 16E8	CAN1 Message Slot 30 Data 2 (C1MSL30DT2)	CAN1 Message Slot 30 Data 3 (C1MSL30DT3)			13-103 13-105
H'0080 16EA	CAN1 Message Slot 30 Data 4 (C1MSL30DT4)	CAN1 Message Slot 30 Data 5 (C1MSL30DT5)			13-107 13-109
H'0080 16EC	CAN1 Message Slot 30 Data 6 (C1MSL30DT6)	CAN1 Message Slot 30 Data 7 (C1MSL30DT7)			13-111 13-113
H'0080 16EE	CAN1 Message Slot 30 Timestamp (C1MSL30TSP)				13-115
H'0080 16F0	CAN1 Message Slot 31 Standard ID0 (C1MSL31SID0)	CAN1 Message Slot 31 Standard ID1 (C1MSL31SID1)			13-87 13-89
H'0080 16F2	CAN1 Message Slot 31 Extended ID0 (C1MSL31EID0)	CAN1 Message Slot 31 Extended ID1 (C1MSL31EID1)			13-91 13-93
H'0080 16F4	CAN1 Message Slot 31 Extended ID2 (C1MSL31EID2)	CAN1 Message Slot 31 Data Length Register (C1MSL31DLC)			13-95 13-97
H'0080 16F6	CAN1 Message Slot 31 Data 0 (C1MSL31DT0)	CAN1 Message Slot 31 Data 1 (C1MSL31DT1)			13-99 13-101
H'0080 16F8	CAN1 Message Slot 31 Data 2 (C1MSL31DT2)	CAN1 Message Slot 31 Data 3 (C1MSL31DT3)			13-103 13-105
H'0080 16FA	CAN1 Message Slot 31 Data 4 (C1MSL31DT4)	CAN1 Message Slot 31 Data 5 (C1MSL31DT5)			13-107 13-109
H'0080 16FC	CAN1 Message Slot 31 Data 6 (C1MSL31DT6)	CAN1 Message Slot 31 Data 7 (C1MSL31DT7)			13-111 13-113
H'0080 16FE	CAN1 Message Slot 31 Timestamp (C1MSL31TSP)				13-115
	(Use inhibited area)				

## SFR Area Register Map (36/37)

Address	+0 address		+1 address		See pages
	b0	b7	b8	b15	
H'0080 2000	DIN Interrupt Request Status Register (DRIDINIST)		DIN Interrupt Request Enable Register (DRIDINIEN)		14-9
H'0080 2002	DEC Interrupt Request Status Register (DRIDECIST)		DEC Interrupt Request Enable Register (DRIDECIEN)		14-10
H'0080 2004	DRI Transfer Interrupt Request Status Register (DRITRMIST)		DRI Transfer Interrupt Request Enable Register (DRITRMIEN)		14-11 14-12
H'0080 2006	DRI Transfer Control Register (DRITRMCNT)		DRI Special Mode Register (DRISPMOD)		14-13 14-15
H'0080 2008	DRI Data Capture Control Register (DRIDCAPCNT)				14-18
H'0080 200A	DRI Data Interleave Control Register (DRIDSELCNT)		DIN Input Event Select Register (DINSEL)		14-22
H'0080 200C	DD Input Enable Register 0 (DRIDDEN0)		DD Input Enable Register 1 (DRIDDEN1)		14-23
H'0080 200E	DD Input Enable Register 2 (DRIDDEN2)		DD Input Enable Register 3 (DRIDDEN3)		14-23 14-24
H'0080 2010	DRI Data Capture Event Count Setting Register (Upper)				14-25
H'0080 2012	(Lower)				
H'0080 2014	DRI Capture Event Counter (Upper)				14-26
H'0080 2016	(Lower)				
H'0080 2018	DRI Transfer Counter (Upper)				14-27
H'0080 201A	(Lower)				
	(Use inhibited area)				
H'0080 2020	DRI Address Reload Register 0 (Upper)				14-29
H'0080 2022	(Lower)				
H'0080 2024	DRI Address Counter 0 (Upper)				14-28
H'0080 2026	(Lower)				
H'0080 2028	DRI Address Reload Register 1 (Upper)				14-29
H'0080 202A	(Lower)				
H'0080 202C	DRI Address Counter 1 (Upper)				14-28
H'0080 202E	(Lower)				
H'0080 2030	DIN Input Processing Control Register (DINCNT)				14-30
H'0080 2032	DEC0 Control Register (DEC0CNT)		(Use inhibited area)		14-31
H'0080 2034	DEC0 Reload Register (DEC0RLD)				14-36
H'0080 2036	DEC0 Counter (DEC0CT)				14-36
H'0080 2038	DEC1 Control Register (DEC1CNT)		(Use inhibited area)		14-31
H'0080 203A	DEC1 Reload Register (DEC1RLD)				14-36
H'0080 203C	DEC1 Counter (DEC1CT)				14-36
H'0080 203E	DEC2 Control Register (DEC2CNT)		(Use inhibited area)		14-32
H'0080 2040	DEC2 Reload Register (DEC2RLD)				14-36
H'0080 2042	DEC2 Counter (DEC2CT)				14-36
H'0080 2044	DEC3 Control Register (DEC3CNT)		(Use inhibited area)		14-32

## SFR Area Register Map (37/37)

Address	+0 address		+1 address		See pages
	b0	b7	b8	b15	
H'0080 2046	DEC3 Reload Register (DEC3RLD)				14-36
H'0080 2048	DEC3 Counter (DEC3CT)				14-36
H'0080 204A	DEC4 Control Register (DEC4CNT)		(Use inhibited area)		14-33
H'0080 204C	DEC4 Reload Register (DEC4RLD)				14-36
H'0080 204E	DEC4 Counter (DEC4CT)				14-36
	(Use inhibited area)				
H'0080 3FFE	(Use inhibited area)				

Note 1 : Address H'0080 0600 to H'0080 0603 are dummy areas.

When there is access to these areas, writing value is disabled and reading value is undefined.

In addition, it does not effect on the other SFR area by writing and reading out operation to dummy access area.

Note 2 : This area exists only in the 32192 and it is use prohibition area in the 32195/32196.

Note 3 : This area exists only in the 32192/32196 and it is use prohibition area in the 32195.



## NBD Control Area Register Map

Address	+0 address		+1 address		See pages
	b0	b7	b8	b15	
H'E000 0000	NBD Enable Register (NBDENB)		(Use inhibited area)		16-6
H'E000 0002	(Use inhibited area)				
H'E000 0004	NBD Pin Control Register (NBDPNCNT)		(Use inhibited area)		16-4
H'E000 0006	(Use inhibited area)				
H'E000 0008	Event Generation Register (NEVNTGEN)		(Use inhibited area)		16-12

### 3.5 EIT Vector Entry

The EIT vector entry is located at the beginning of the internal ROM/external extension areas. The branch instruction for jumping to the start address of each EIT event processing handler is written here. Note that it is the branch instruction and not the jump address itself that is written here. For details, see Chapter 4, "EIT."

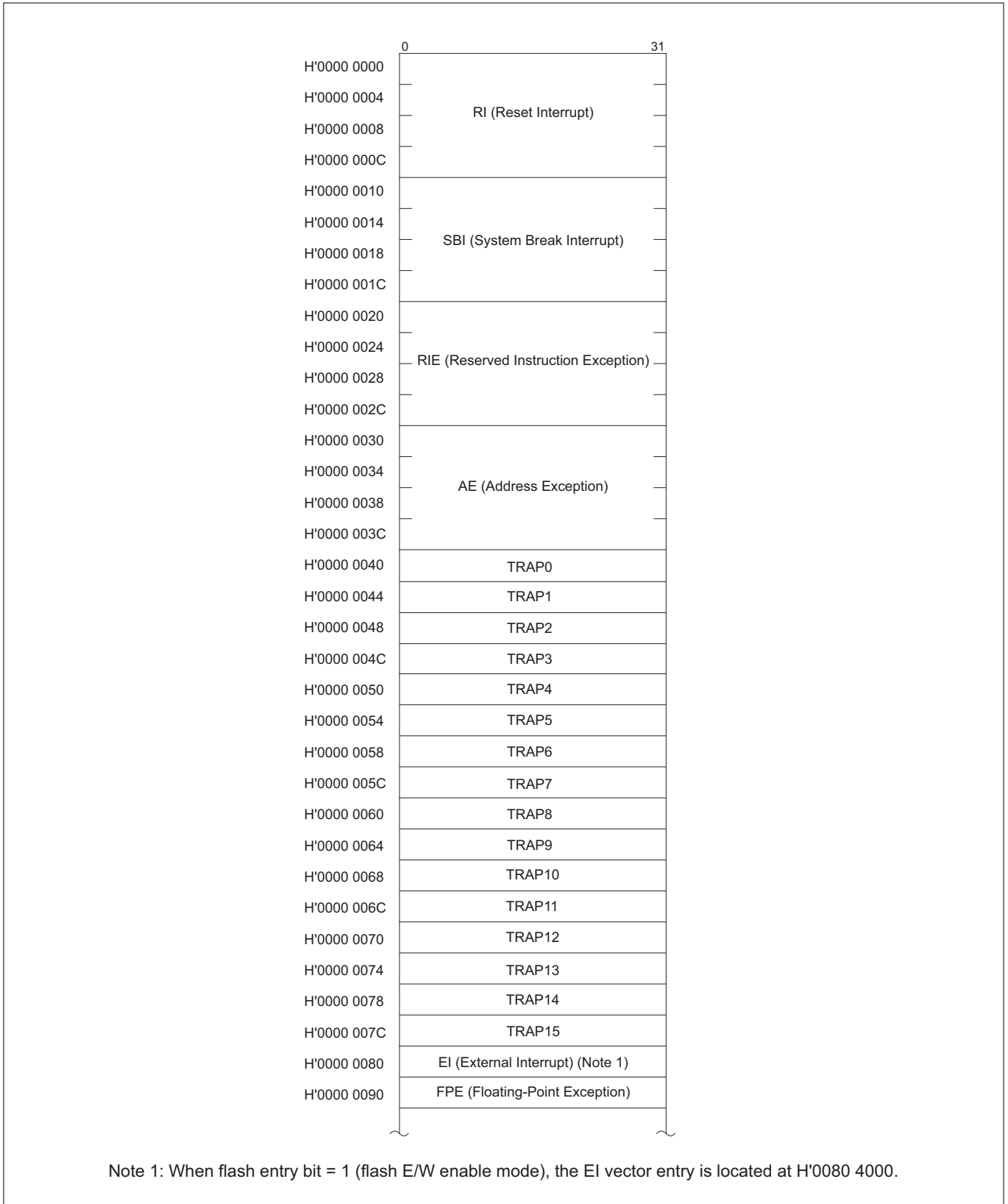


Figure 3.5.1 EIT Vector Entry

### 3.6 ICU Vector Table

The ICU vector table is used by the internal interrupt controller of the microcomputer. This table has the addresses shown below, at which the start addresses of interrupt handlers for the interrupt requests from respective internal peripheral I/Os are set. For details, see Chapter 5, "Interrupt Controller."

ICU Vector Table Memory Map (1/3)

Address	+0 address		+1 address	
	b0	b7	b8	b15
H'0000 0094	MJT Input Interrupt 4 Handler Start Address (A0–A15)			
H'0000 0096	MJT Input Interrupt 4 Handler Start Address (A16–A31)			
H'0000 0098	MJT Input Interrupt 3 Handler Start Address (A0–A15)			
H'0000 009A	MJT Input Interrupt 3 Handler Start Address (A16–A31)			
H'0000 009C	MJT Input Interrupt 2 Handler Start Address (A0–A15)			
H'0000 009E	MJT Input Interrupt 2 Handler Start Address (A16–A31)			
H'0000 00A0	MJT Input Interrupt 1 Handler Start Address (A0–A15)			
H'0000 00A2	MJT Input Interrupt 1 Handler Start Address (A16–A31)			
H'0000 00A4	MJT Input Interrupt 0 Handler Start Address (A0–A15)			
H'0000 00A6	MJT Input Interrupt 0 Handler Start Address (A16–A31)			
H'0000 00A8	MJT Output Interrupt 7 Handler Start Address (A0–A15)			
H'0000 00AA	MJT Output Interrupt 7 Handler Start Address (A16–A31)			
H'0000 00AC	MJT Output Interrupt 6 Handler Start Address (A0–A15)			
H'0000 00AE	MJT Output Interrupt 6 Handler Start Address (A16–A31)			
H'0000 00B0	MJT Output Interrupt 5 Handler Start Address (A0–A15)			
H'0000 00B2	MJT Output Interrupt 5 Handler Start Address (A16–A31)			
H'0000 00B4	MJT Output Interrupt 4 Handler Start Address (A0–A15)			
H'0000 00B6	MJT Output Interrupt 4 Handler Start Address (A16–A31)			
H'0000 00B8	MJT Output Interrupt 3 Handler Start Address (A0–A15)			
H'0000 00BA	MJT Output Interrupt 3 Handler Start Address (A16–A31)			
H'0000 00BC	MJT Output Interrupt 2 Handler Start Address (A0–A15)			
H'0000 00BE	MJT Output Interrupt 2 Handler Start Address (A16–A31)			
H'0000 00C0	MJT Output Interrupt 1 Handler Start Address (A0–A15)			
H'0000 00C2	MJT Output Interrupt 1 Handler Start Address (A16–A31)			
H'0000 00C4	MJT Output Interrupt 0 Handler Start Address (A0–A15)			
H'0000 00C6	MJT Output Interrupt 0 Handler Start Address (A16–A31)			
H'0000 00C8	DMA0–4 Interrupt Handler Start Address (A0–A15)			
H'0000 00CA	DMA0–4 Interrupt Handler Start Address (A16–A31)			
H'0000 00CC	SIO1 Receive Interrupt Handler Start Address (A0–A15)			
H'0000 00CE	SIO1 Receive Interrupt Handler Start Address (A16–A31)			
H'0000 00D0	SIO1 Transmit Interrupt Handler Start Address (A0–A15)			
H'0000 00D2	SIO1 Transmit Interrupt Handler Start Address (A16–A31)			
H'0000 00D4	SIO0 Receive Interrupt Handler Start Address (A0–A15)			
H'0000 00D6	SIO0 Receive Interrupt Handler Start Address (A16–A31)			

ICU Vector Table Memory Map (2/3)

Address	+0 address		+1 address	
	b0	b7	b8	b15
H'0000 00D8	SIO0 Transmit Interrupt Handler Start Address (A0–A15)			
H'0000 00DA	SIO0 Transmit Interrupt Handler Start Address (A16–A31)			
H'0000 00DC	A/D0 Conversion Interrupt Handler Start Address (A0–A15)			
H'0000 00DE	A/D0 Conversion Interrupt Handler Start Address (A16–A31)			
H'0000 00E0	TID0 Input Interrupt Handler Start Address (A0–A15)			
H'0000 00E2	TID0 Input Interrupt Handler Start Address (A16–A31)			
H'0000 00E4	TOU0 Output Interrupt Handler Start Address (A0–A15)			
H'0000 00E6	TOU0 Output Interrupt Handler Start Address (A16–A31)			
H'0000 00E8	DMA5–9 Interrupt Handler Start Address (A0–A15)			
H'0000 00EA	DMA5–9 Interrupt Handler Start Address (A16–A31)			
H'0000 00EC	SIO2, 3 Transmit/receive Interrupt Handler Start Address (A0–A15)			
H'0000 00EE	SIO2, 3 Transmit/receive Interrupt Handler Start Address (A16–A31)			
H'0000 00F0	RTD Interrupt Handler Start Address (A0–A15)			
H'0000 00F2	RTD Interrupt Handler Start Address (A16–A31)			
H'0000 00F4	TID1 Input Interrupt Handler Start Address (A0–A15)			
H'0000 00F6	TID1 Input Interrupt Handler Start Address (A16–A31)			
H'0000 00F8	TOU1 Output Interrupt Handler Start Address (A0–A15)			
H'0000 00FA	TOU1 Output Interrupt Handler Start Address (A16–A31)			
H'0000 00FC	SIO4, 5 Transmit/receive Interrupt Handler Start Address (A0–A15)			
H'0000 00FE	SIO4, 5 Transmit/receive Interrupt Handler Start Address (A16–A31)			
H'0000 0100				
H'0000 0102				
H'0000 0104				
H'0000 0106				
H'0000 0108	TML1 Input Interrupt Handler Start Address (A0–A15)			
H'0000 010A	TML1 Input Interrupt Handler Start Address (A16–A31)			
H'0000 010C	CAN0 Transmit/receive & Error Interrupt Handler Start Address (A0–A15)			
H'0000 010E	CAN0 Transmit/receive & Error Interrupt Handler Start Address (A16–A31)			
H'0000 0110	CAN1 Transmit/receive & Error Interrupt Handler Start Address (A0–A15)			
H'0000 0112	CAN1 Transmit/receive & Error Interrupt Handler Start Address (A16–A31)			
H'0000 0114	DRI Transfer Interrupt Handler Start Address (A0–A15)			
H'0000 0116	DRI Transfer Interrupt Handler Start Address (A16–A31)			
H'0000 0118	DRI Counter Interrupt Handler Start Address (A0–A15)			
H'0000 011A	DRI Counter Interrupt Handler Start Address (A16–A31)			
H'0000 011C	DRI Event Detection Interrupt Handler Start Address (A0–A15)			
H'0000 011E	DRI Event Detection Interrupt Handler Start Address (A16–A31)			
H'0000 0120	CAN0 Transmit/receive Completion Interrupt Handler Start Address (A0–A15)			
H'0000 0122	CAN0 Transmit/receive Completion Interrupt Handler Start Address (A16–A31)			

## ICU Vector Table Memory Map (3/3)

Address	+0 address		+1 address	
	b0	b7	b8	b15
H'0000 0124	CAN0 Single-shot Interrupt Handler Start Address (A0–A15)			
H'0000 0126	CAN0 Single-shot Interrupt Handler Start Address (A16–A31)			
H'0000 0128	CAN0 Error Interrupt Handler Start Address (A0–A15)			
H'0000 012A	CAN0 Error Interrupt Handler Start Address (A16–A31)			
H'0000 012C	CAN1 Transmit/receive Completion Interrupt Handler Start Address (A0–A15)			
H'0000 012E	CAN1 Transmit/receive Completion Interrupt Handler Start Address (A16–A31)			
H'0000 0130	CAN1 Single-shot Interrupt Handler Start Address (A0–A15)			
H'0000 0132	CAN1 Single-shot Interrupt Handler Start Address (A16–A31)			
H'0000 0134	CAN1 Error Interrupt Handler Start Address (A0–A15)			
H'0000 0136	CAN1 Error Interrupt Handler Start Address (A16–A31)			
H'0000 0138	RAM Write Monitor Interrupt Handler Start Address (A0–A15)			
H'0000 013A	RAM Write Monitor Interrupt Handler Start Address (A16–A31)			

### 3.7 Notes on Address Space

- **Virtual flash emulation function**

The microcomputer has the function to map 8-Kbyte memory blocks of the internal RAM (maximum for 32192 is 16 blocks, for 32195 is 4 blocks, for 32196 is 8 blocks) into areas (L banks) of the internal flash memory that are divided in 8-Kbyte units. This function is referred to as the Virtual Flash Emulation Function.

This function allows the data located in 8-Kbyte blocks of the internal RAM to be changed with the contents of internal flash memory at the addresses specified by the Virtual Flash L Bank Register. That way, the relevant RAM data can read out by reading the content of internal flash memory. For details about this function, see Section 6.7, "Virtual Flash Emulation Function."

- **Dummy access area**

Address H'0080 0600 to H'0080 0603 are dummy areas.

When there is access to these areas, writing value is disabled and reading value is undefined.

In addition, it does not effect on the other SFR area by writing and reading out operation to dummy access area.

# CHAPTER 4

---

## EIT

- 4.1 Outline of EIT
- 4.2 EIT Events
- 4.3 EIT Processing Procedure
- 4.4 EIT Processing Mechanism
- 4.5 Acceptance of EIT Events
- 4.6 Saving and Restoring the PC and PSW
- 4.7 EIT Vector Entry
- 4.8 Exception Processing
- 4.9 Interrupt Processing
- 4.10 Trap Processing
- 4.11 EIT Priority Levels
- 4.12 Example of EIT Processing
- 4.13 Notes on EIT

## 4.1 Outline of EIT

If some event occurs when the CPU is executing an ordinary program, it may become necessary to suspend the program being executed and execute another program. Events like this one are referred to by a generic name as EIT (Exception, Interrupt and Trap).

### (1) Exception

This is an event related to the context being executed. It is generated by an error or violation during instruction execution. This type of event includes Address Exception (AE), Reserved Instruction Exception (RIE) and Floating-Point Exception (FPE).

### (2) Interrupt

This is an event generated irrespective of the context being executed. It is generated by a hardware-derived signal from an external source, as well as by the internal peripheral I/O. This type of event includes Reset Interrupt (RI), System Break Interrupt (SBI) and External Interrupt (EI).

### (3) Trap

This refers to a software interrupt generated by executing a TRAP instruction. This type of event is intentionally generated in a program as in the OS's system call by the programmer.

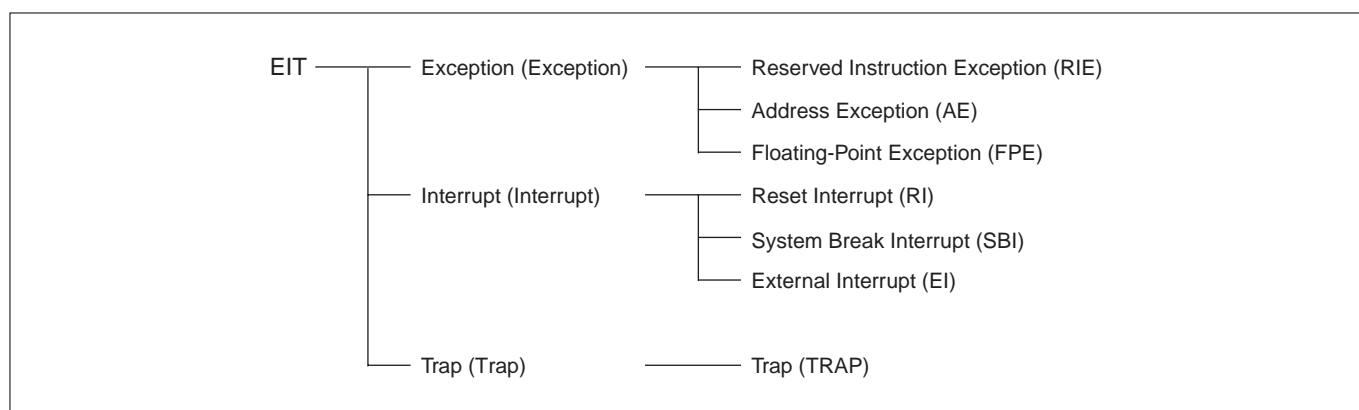


Figure 4.1.1 Classification of EITs



## 4.2 EIT Events

### 4.2.1 Exception

#### (1) Reserved Instruction Exception (RIE)

Reserved Instruction Exception (RIE) occurs when execution of a reserved instruction (unimplemented instruction) is detected.

#### (2) Address Exception (AE)

Address Exception (AE) occurs when an attempt is made to access a misaligned address in Load or Store instructions.

#### (3) Floating-point Exception (FPE)

Floating-point Exception (FPE) occurs when Unimplemented Exception (UIPL) or one of the five exceptions specified in the IEEE 754 standard (OVF/UDF/IXCT/DIV0/IVLD) is detected. Each exception processing is outlined below.

##### 1) Overflow Exception (OVF)

The exception occurs when the absolute value of the operation result exceeds the largest describable precision in the floating-point format. The following table shows the operation results when an OVF occurs.

**Table 4.2.1 Operation Results When an OVF Occurred**

Rounding Mode	Sign of the Result	Operation Result (Content of the Destination Register)	
		When the OVF EIT processing is masked (Note 1)	When the OVF EIT processing is executed (Note 2)
-Infinity	+	+MAX	No change
	-	-Infinity	
+Infinity	+	+Infinity	
	-	-MAX	
0	+	+MAX	
	-	-MAX	
Nearest	+	+Infinity	
	-	-Infinity	

Note 1: When the overflow exception enable (EO) bit (FPSR register bit 20) = "0"

Note 2: When the overflow exception enable (EO) bit (FPSR register bit 20) = "1"

Notes: • If an OVF occurs while EIT processing for OVF is masked, an IXCT occurs at the same time.

• +MAX = H'7F7F FFFF, -MAX = H'FF7F FFFF

##### 2) Underflow Exception (UDF)

The exception occurs when the absolute value of the operation result is less than the largest describable precision in the floating-point format. The following table shows the operation results when a UDF occurs.

**Table 4.2.2 Operation Results when a UDF Occurred**

Operation Result (Content of the Destination Register)	
When UDF EIT processing is masked (Note 1)	When UDF EIT processing is executed (Note 2)
DN = 0: An unimplemented exception occurs DN = 1: 0 is returned	No change

Note 1: When the underflow exception enable (EU) bit (FPSR register bit 18) = "0"

Note 2: When the underflow exception enable (EU) bit (FPSR register bit 18) = "1"

### 3) Inexact Exception (IXCT)

The exception occurs when the operation result differs from a result led out with an infinite range of precision. The following table shows the operation results and the respective conditions in which each IXCT occurs.

**Table 4.2.3 Operation Results when an IXCT Occurred**

Occurrence Condition	Operation Result (Content of the Destination Register)	
	When the IXCT EIT processing is masked (Note 1)	When the IXCT EIT processing is executed (Note 2)
Overflow occurs in OVF masked condition	Reference OVF operation results	No change
Rounding occurs	Rounded value	No change

Note 1: When the inexact exception enable (EX) bit (FPSR register bit 17) = "0"

Note 2: When the inexact exception enable (EX) bit (FPSR register bit 17) = "1"

### 4) Zero Division Exception (DIV0)

The exception occurs when a finite nonzero value is divided by zero. The following table shows the operation results when a DIV0 is occurs.

**Table 4.2.4 Operation Results When a DIV0 Occurred**

Dividend	Operation Result (Content of the Destination Register)	
	When the DIV0 EIT processing is masked (Note 1)	When the DIV0 EIT processing is executed (Note 2)
Nonzero finite value	+/-Infinity (Sign is derived by exclusive ORing the signs of the divisor and dividend.)	No change

Note 1: When the zero division exception enable (EZ) bit (FPSR register bit 19) = "0"

Note 2: When the zero division exception enable (EZ) bit (FPSR register bit 19) = "1"

Please note that the DIV0 EIT processing does not occur in the following conditions.

**Table 4.2.5 Cases in Which No DIV0 Occur**

Dividend	Behavior
0	An invalid operation exception occurs
Infinity	No exceptions occur (with the result = "Infinity")

### 5) Invalid Operation Exception (IVLD)

The exception occurs when an invalid operation is executed. The following table shows the operation results and the respective conditions in which each IVLD occurs.

**Table 4.2.6 Operation Results When an IVLD Occurred**

Occurrence Condition		Operation Result (Content of the Destination Register)	
		When the IVLD EIT processing is masked (Note 1)	When the IVLD EIT processing is executed (Note 2)
Operation for SNaN operand		QNaN	No change
+Infinity-(+Infinity), -Infinity-(-Infinity)			
0 x Infinity			
0 / 0, Infinity / Infinity			
<ul style="list-style-type: none"> <li>When an integer conversion overflowed</li> <li>When NaN or Infinity was converted into an integer</li> </ul>	When FTOI instruction was executed	Return value when pre-conversion signed bit is: "0": H'7FFF FFFF "1": H'8000 0000	No change
	When FTOS instruction was executed	Return value when pre-conversion signed bit is: "0": H'0000 7FFF "1": H'FFFF 8000	
When < or > comparison was performed on NaN		Comparison results (comparison invalid)	

Note 1: When the invalid operation exception enable (EV) bit (FPSR register bit 21) = "0"

Note 2: When the invalid operation exception enable (EV) bit (FPSR register bit 21) = "1"

Note: • NaN (Not a Number)

SNaN (Signaling NaN): a NaN in which the MSB of the decimal field is "0." When SNaN is used as the source operand in an operation, an IVLD occurs. SNaNs are useful in identifying program bugs when used as the initial value in a variable. However, SNaNs cannot be generated by hardware.

QNaN (Quiet NaN): a NaN in which the MSB of the decimal field is "1." Even when QNaN is used as the source operand in an operation, an IVLD will not occur (excluding comparison and format conversion). Because a result can be influenced by the arithmetic operations, QNaN allows the user to debug without executing an EIT processing. QNaNs are created by hardware.

### 6) Unimplemented Exception (UIPL)

The exception occurs when the denormalized number zero flush (DN) bit (FPSR register bit 23) = "0" and a denormalized number is given as an operation operand. (Note 1)

Because the UIPL has no enable bits available, it cannot be masked when they occur. The destination register remains unchanged.

Note 1: A UDF occurs when the intermediate result of an operation is a denormalized number, in which case if the DN bit (FPSR register bit 23) = "0", an UIPL occurs.

## 4.2.2 Interrupt

### (1) Reset Interrupt (RI)

Reset Interrupt (RI) is always accepted by entering the RESET# signal. The reset interrupt is assigned the highest priority.

For details about the reset interrupt, see Chapter 7, "Reset."

### (2) System Break Interrupt (SBI)

System Break Interrupt (SBI) is an emergency interrupt which is used when power outage is detected or a fault condition is notified by an external watchdog timer. This interrupt can only be used in cases when after interrupt processing, control will not return to the program that was being executed when the interrupt occurred.

### (3) External Interrupt (EI)

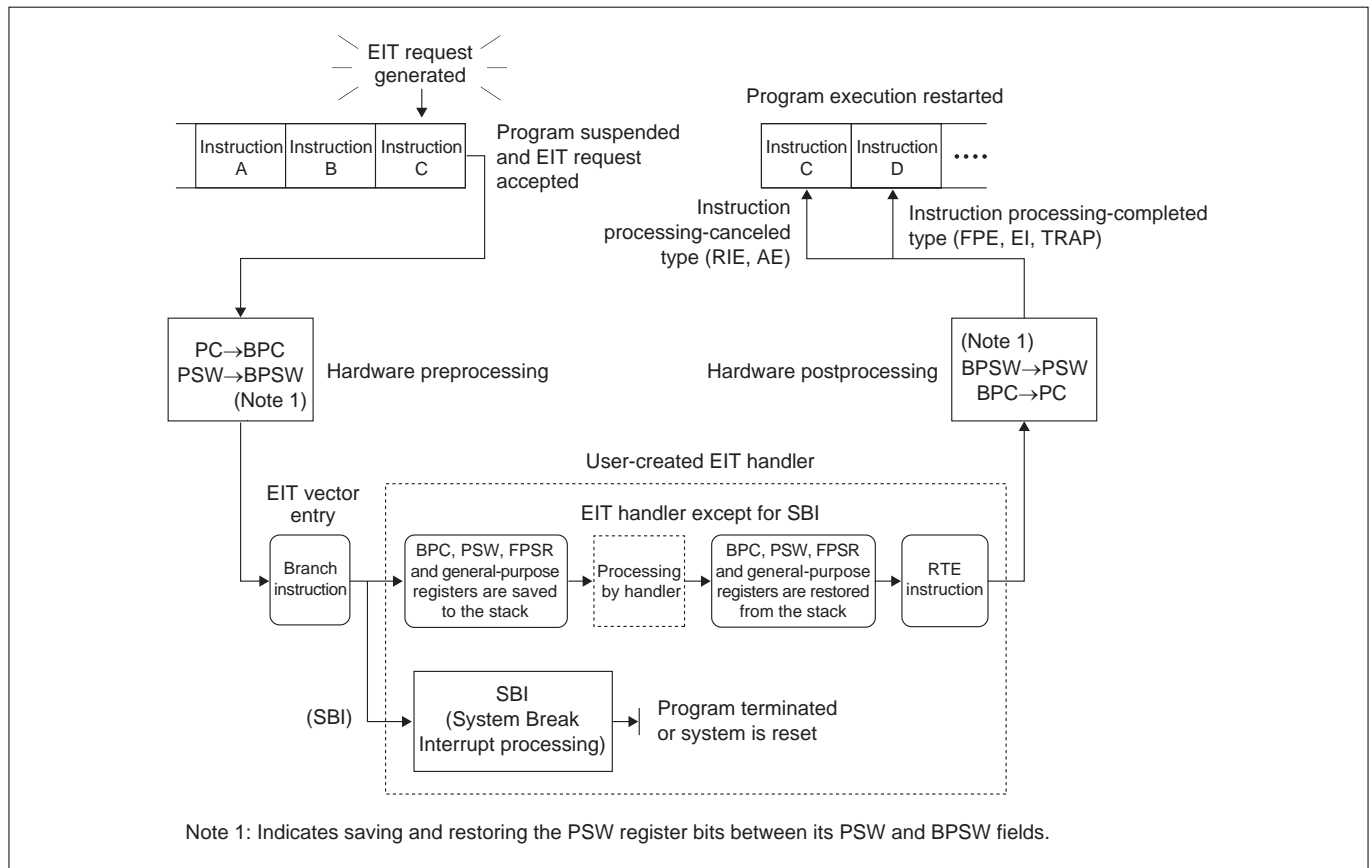
External Interrupt (EI) is requested from internal peripheral I/Os managed by the interrupt controller. The interrupt controller manages these interrupts by assigning each one of eight priority levels including an interrupt-disabled state.

### 4.2.3 Trap

Traps are software interrupts which are generated by executing the TRAP instruction. Sixteen distinct vector addresses are provided corresponding to TRAP instruction operands 0–15.

## 4.3 EIT Processing Procedure

EIT processing consists of two parts, one in which they are handled automatically by hardware, and one in which they are handled by user-created programs (EIT handlers). The procedure for processing EITs when accepted, except for a reset interrupt, is shown below.



**Figure 4.3.1 Outline of the EIT Processing Procedure**

When an EIT is accepted, the CPU branches to the EIT vector after hardware preprocessing (as will be described later). The EIT vector has an entry address assigned for each EIT. This is where the BRA (branch) instruction for the EIT handler (not the jump address itself) is written.

In the hardware preprocessing, the PC is transferred to the BPC (backup PC), and the content of the PSW register's PSW field is transferred to the BPSW field in that register.

Other necessary operations must be performed in the user-created EIT handler. These include saving the BPC and PSW registers (including the BPSW field) and the general-purpose registers to be used in the EIT handler to the stack. In addition, the accumulator and the FPSR register must be saved to the stack as necessary. Remember that all these registers must be saved to the stack in a program by the user.

When processing by the EIT handler is completed, restore the saved registers from the stack and finally execute the RTE instruction. Control is thereby returned from the EIT processing to the program that was being executed when the EIT occurred. (This does not apply to the System Break Interrupt, however.)

In the hardware postprocessing, the BPC is returned to the PC, and the content of the PSW register's BPSW field is returned to the PSW field in that register. Note that the values stored in the BPC and the PSW register's BPSW field after executing the RTE instruction are undefined.

## 4.4 EIT Processing Mechanism

The EIT processing mechanism consists of the M32R CPU core and the interrupt controller for internal peripheral I/Os. It also has the backup registers for the PC and PSW (the BPC register and the BPSW field of the PSW register). The EIT processing mechanism is shown below.

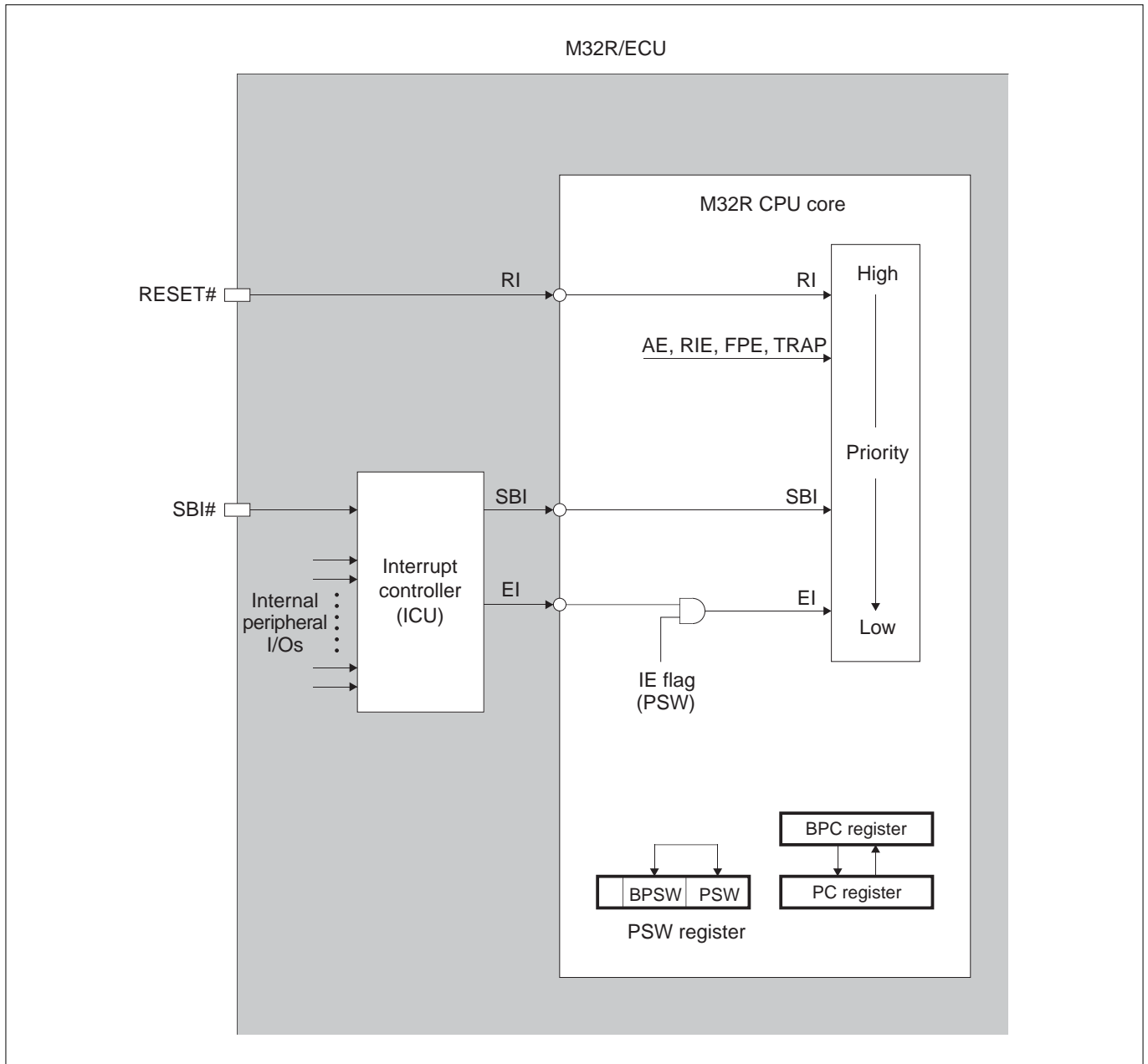


Figure 4.4.1 EIT Processing Mechanism

## 4.5 Acceptance of EIT Events

When an EIT event occurs, the CPU suspends the program it has hitherto been executed and branches to EIT processing by the relevant handler. Conditions under which each EIT event occurs and the timing at which they are accepted are shown below.

**Table 4.5.1 Acceptance of EIT Events**

EIT Event	Type of Processing	Acceptance Timing	Values Set in BPC Register
Reserved Instruction Exception (RIE)	Instruction processing-canceled type	During instruction execution	PC value of the instruction that generated RIE
Address Exception (AE)	Instruction processing-canceled type	During instruction execution	PC value of the instruction that generated AE
Floating-Point Exception (FPE)	Instruction processing-completed type	Break in instructions	PC value of the instruction that generated FPE + 4
Reset Interrupt (RI)	Instruction processing-aborted type	Each machine cycle	Undefined value
System Break Interrupt (SBI)	Instruction processing-completed type	Break in instructions (word boundary only)	PC value of the next instruction
External Interrupt (EI)	Instruction processing-completed type	Break in instructions (word boundary only)	PC value of the next instruction
Trap (TRAP)	Instruction processing-completed type	Break in instructions	PC value of TRAP instruction + 4

## 4.6 Saving and Restoring the PC and PSW

The following describes operation of the microcomputer at the time when it accepts an EIT and when it executes the RTE instruction.

### (1) Hardware preprocessing when an EIT is accepted

[1] Save the PSW register's SM, IE and C bits in its backup field.

```
BSM ← SM
BIE ← IE
BC ← C
```

[2] Update the PSW register's SM, IE and C bits

```
SM ← Remains unchanged (RIE, AE, FPE, TRAP) or cleared to "0" (SBI, EI, RI)
IE ← Cleared to "0"
C ← Cleared to "0"
```

[3] Save the PC register

```
BPC ← PC
```

[4] Set the vector address in the PC register

Branches to the EIT vector and executes the branch (BRA) instruction written in it, thereby transferring control to the user-created EIT handler.

### (2) Hardware postprocessing when the RTE instruction is executed

[A] Restore the PSW register's SM, IE and C bits from its backup field.

```
SM ← BSM
IE ← BIE
C ← BC
```

[B] Restore the PC register from the BPC register.

```
PC ← BPC
```

Note: • The values stored in the BPC and the PSW register's BSM, BIE and BC bits after executing the RTE instruction are undefined.

[1] Saving the SM, IE and C bits

BSM ← SM  
 BIE ← IE  
 BC ← C

[2] Updating the SM, IE and C bits

SM ← Unchanged or 0  
 IE ← 0  
 C ← 0

[A] Restoring the SM, IE and C bits from the backup field

SM ← BSM  
 IE ← BIE  
 C ← BC

[3] Saving the PC

BPC ← PC

[4] Setting the vector address in the PC

PC ← Vector address

[B] Restoring the PC from the BPC register

The value stored in the BPC register after executing the RTE instruction is undefined.

The values stored in the BSM, BIE and BC bits after executing the RTE instruction are undefined.

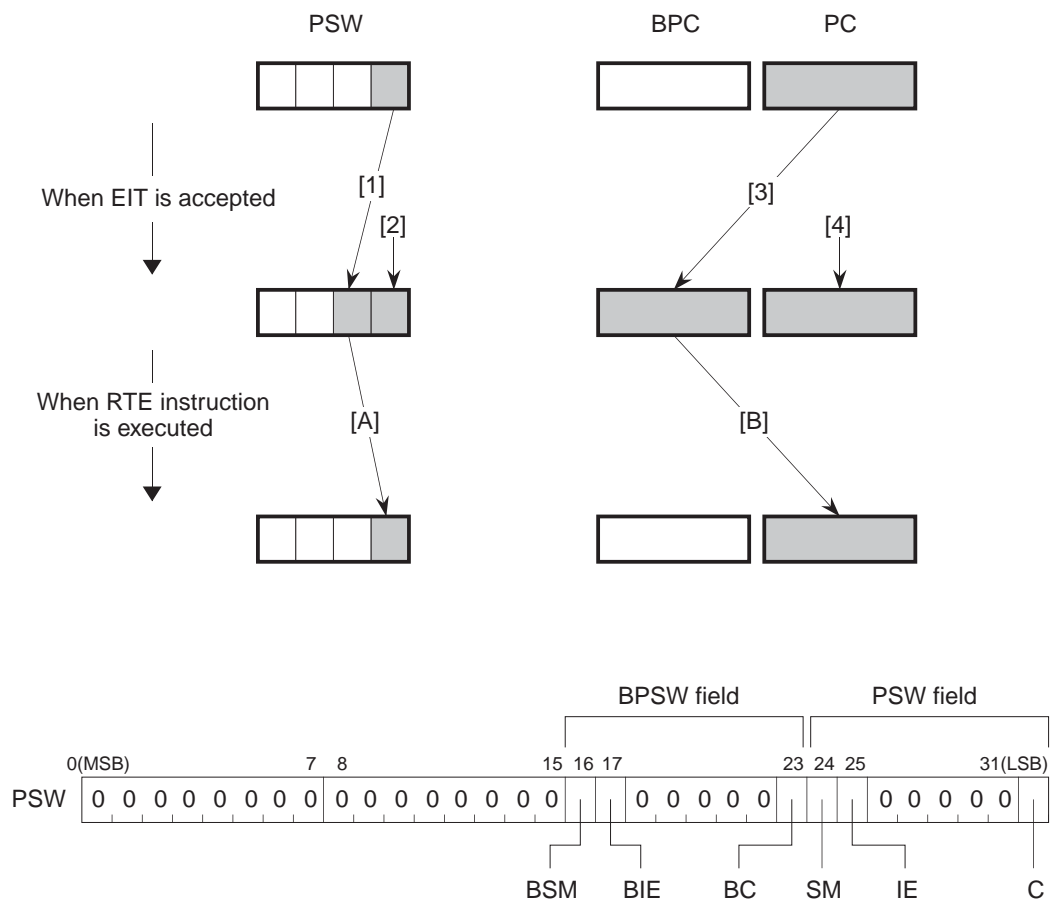


Figure 4.6.1 Saving and Restoring the PC and PSW

## 4.7 EIT Vector Entry

The EIT vector entry is located in the user space beginning with the address H'0000 0000. The table below lists the EIT vector entry and shows the states of SM bit, IE bit, and BPC bit after the occurrence of each EIT event.

**Table 4.7.1 EIT Vector Entry**

Name	Abbreviation	Vector Address	SM	IE	BPC
Reset Interrupt	RI	H'0000 0000 (Note 1)	0	0	Undefined
System Break Interrupt	SBI	H'0000 0010	0	0	PC of the next instruction
Reserved Instruction Exception	RIE	H'0000 0020	Unchanged	0	PC of the instruction that generated RIE
Address Exception	AE	H'0000 0030	Unchanged	0	PC of the instruction that generated AE
Trap	TRAP0	H'0000 0040	Unchanged	0	PC of TRAP instruction + 4
	TRAP1	H'0000 0044	Unchanged	0	PC of TRAP instruction + 4
	TRAP2	H'0000 0048	Unchanged	0	PC of TRAP instruction + 4
	TRAP3	H'0000 004C	Unchanged	0	PC of TRAP instruction + 4
	TRAP4	H'0000 0050	Unchanged	0	PC of TRAP instruction + 4
	TRAP5	H'0000 0054	Unchanged	0	PC of TRAP instruction + 4
	TRAP6	H'0000 0058	Unchanged	0	PC of TRAP instruction + 4
	TRAP7	H'0000 005C	Unchanged	0	PC of TRAP instruction + 4
	TRAP8	H'0000 0060	Unchanged	0	PC of TRAP instruction + 4
	TRAP9	H'0000 0064	Unchanged	0	PC of TRAP instruction + 4
	TRAP10	H'0000 0068	Unchanged	0	PC of TRAP instruction + 4
	TRAP11	H'0000 006C	Unchanged	0	PC of TRAP instruction + 4
	TRAP12	H'0000 0070	Unchanged	0	PC of TRAP instruction + 4
	TRAP13	H'0000 0074	Unchanged	0	PC of TRAP instruction + 4
	TRAP14	H'0000 0078	Unchanged	0	PC of TRAP instruction + 4
	TRAP15	H'0000 007C	Unchanged	0	PC of TRAP instruction + 4
External Interrupt	EI	H'0000 0080 (Note 2)	0	0	PC of the next instruction
Floating-Point Exception	FPE	H'0000 0090	Unchanged	0	PC of the instruction that generated FPE + 4

Note 1: During boot mode, the CPU starts executing the boot program after exiting the reset state. For details, see Section 6.6, "Programming the Internal Flash Memory."

Note 2: During flash E/W enable mode, this vector address is moved to the beginning of the internal RAM (address H'0080 4000). For details, see Section 6.6, "Programming the Internal Flash Memory."



## 4.8 Exception Processing

### 4.8.1 Reserved Instruction Exception (RIE)

#### [Occurrence Conditions]

Reserved Instruction Exception (RIE) occurs when a reserved instruction (unimplemented instruction) is detected. Instruction check is performed on the op-code part of the instruction.

When a reserved instruction exception occurs, the instruction that generated it is not executed. If an external interrupt is requested at the same time a reserved instruction exception is detected, it is the reserved instruction exception that is accepted.

#### [EIT Processing]

##### (1) Saving SM, IE and C bits

The PSW register's SM, IE and C bits are saved to the respective backup bits: BSM, BIE and BC.

```
BSM ← SM
BIE ← IE
BC ← C
```

##### (2) Updating SM, IE and C bits

The PSW register's SM, IE and C bits are updated as shown below.

```
SM ← Unchanged
IE ← 0
C ← 0
```

##### (3) Saving the PC

The PC value of the instruction that generated the reserved instruction exception is set in the BPC register. For example, if the instruction that generated the reserved instruction exception is at address 4, the value 4 is set in the BPC register. Similarly, if the instruction that generated the reserved instruction exception is at address 6, the value 6 is set in the BPC register. In this case, the value of the BPC register bit 30 indicates whether the instruction that generated the reserved instruction exception resides on a word boundary (BPC register bit 30 = "0") or not on a word boundary (BPC register bit 30 = "1").

However, in either case of the above, the address to which the RTE instruction returns after the EIT handler has terminated is address 4. (This is because the 2 low-order address bits are cleared to '00' when returned to the PC.)

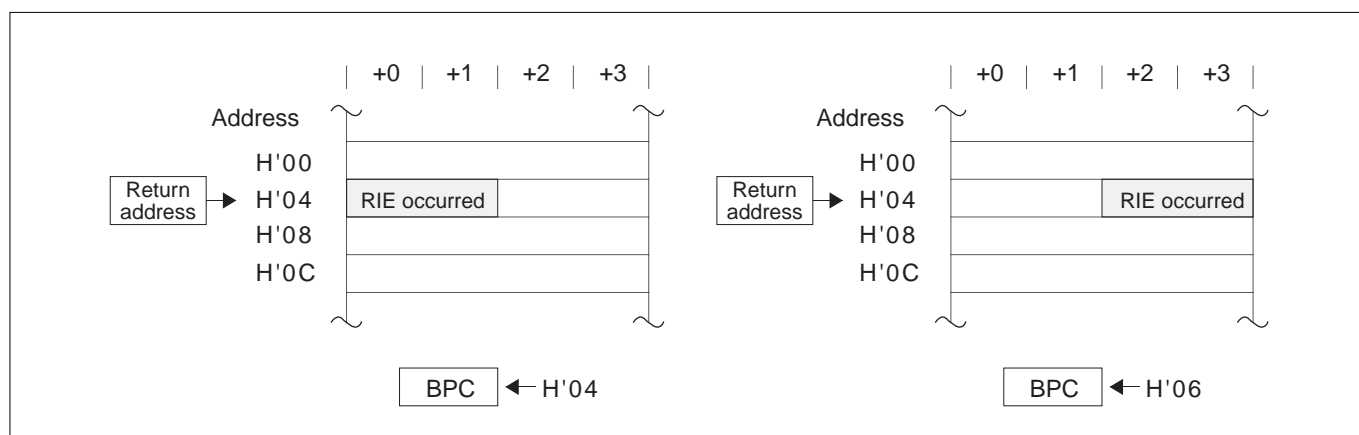


Figure 4.8.1 Example of a Return Address for Reserved Instruction Exception (RIE)

**(4) Branching to the EIT vector entry**

The CPU branches to the address H'0000 0020 in the user space. This is the last operation performed in hardware preprocessing.

**(5) Jumping from the EIT vector entry to the user-created handler**

The CPU executes the BRA instruction written by the user at the address H'0000 0020 of the EIT vector entry to jump to the start address of the user-created handler. At the beginning of the user-created EIT handler, first save the BPC and PSW registers and the necessary general-purpose registers to the stack. Also, save the accumulator and FPSR register as necessary.

**(6) Returning from the EIT handler**

At the end of the EIT handler, restore the saved registers from the stack and execute the RTE instruction. When the RTE instruction is executed, hardware postprocessing is automatically performed. At this time, the CPU restarts from a word-boundary instruction including the instruction that generated a RIE (see Figure 4.8.1). Except when using reserved instruction exceptions intentionally, occurrence of a reserved instruction exception suggests that the system has some fatal fault already existing in it. In such a case, therefore, do not return from the reserved instruction exception handler to the program that was being executed when the exception occurred.

**4.8.2 Address Exception (AE)****[Occurrence Conditions]**

Address Exception (AE) occurs when an attempt is made to access a misaligned address in Load or Store instructions. The following lists the combination of instructions and accessed addresses that may cause address exceptions to occur.

- Two low-order address bits accessed in the LDH, LDUH or STH instruction are '01' or '11'
- Two low-order address bits accessed in the LD, ST, LOCK or UNLOCK instruction are '01,' '10' or '11'

When an address exception occurs, memory access by the instruction that generated the exception is not performed. If an external interrupt is requested at the same time an address exception is detected, it is the address exception that is accepted.

**[EIT Processing]****(1) Saving SM, IE and C bits**

The PSW register's SM, IE and C bits are saved to the respective backup bits: BSM, BIE and BC.

```
BSM ← SM
BIE ← IE
BC ← C
```

**(2) Updating SM, IE and C bits**

The PSW register's SM, IE and C bits are updated as shown below.

```
SM ← Unchanged
IE ← 0
C ← 0
```

**(3) Saving the PC**

The PC value of the instruction that generated the address exception is set in the BPC register. For example, if the instruction that generated the address exception is at address 4, the value 4 is set in the BPC register. Similarly, if the instruction that generated the address exception is at address 6, the value 6 is set in the BPC register. In this case, the value of the BPC register bit 30 indicates whether the instruction that generated the reserved instruction exception resides on a word boundary (BPC register bit 30 = "0") or not on a word boundary (BPC register bit 30 = "1").

However, in either case of the above, the address to which the RTE instruction returns after the EIT handler has terminated is address 4. (This is because the 2 low-order address bits are cleared to '00' when returned to the PC.)

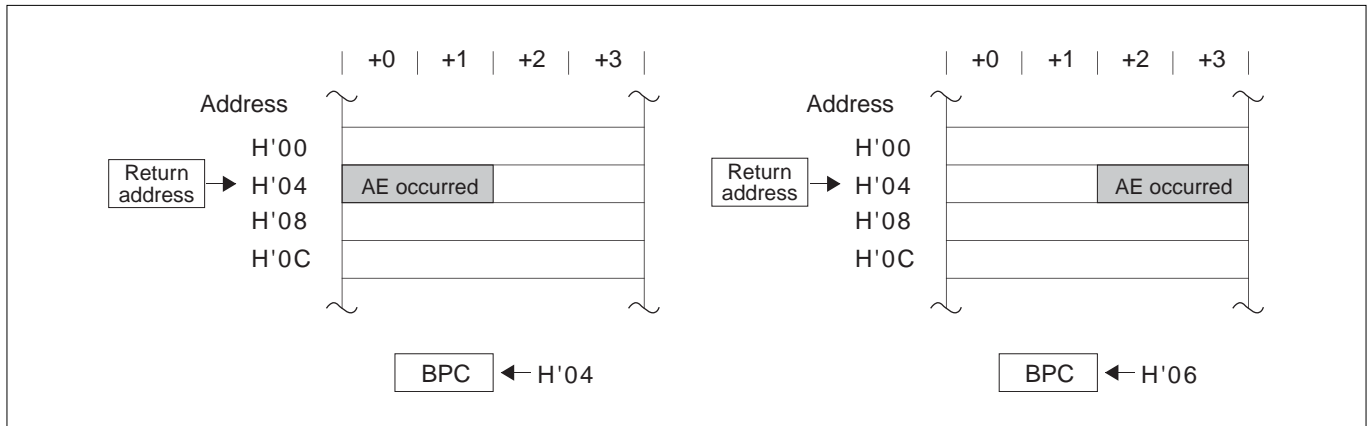


Figure 4.8.2 Example of a Return Address for Address Exception (AE)

#### (4) Branching to the EIT vector entry

The CPU branches to the address H'0000 0030 in the user space. This is the last operation performed in hardware preprocessing.

#### (5) Jumping from the EIT vector entry to the user-created handler

The CPU executes the BRA instruction written by the user at the address H'0000 0030 of the EIT vector entry to jump to the start address of the user-created handler. At the beginning of the user-created EIT handler, first save the BPC and PSW registers and the necessary general-purpose registers to the stack. Also, save the accumulator and FPSR register as necessary.

#### (6) Returning from the EIT handler

At the end of the EIT handler, restore the saved registers from the stack and execute the RTE instruction. When the RTE instruction is executed, hardware postprocessing is automatically performed. At this time, the CPU restarts from a word-boundary instruction including the instruction that generated an AE (see Figure 4.8.2). Except when using address exceptions intentionally, occurrence of an address exception suggests that the system has some fatal fault already existing in it. In such a case, therefore, do not return from the address exception handler to the program that was being executed when the exception occurred.

### 4.8.3 Floating-Point Exception (FPE)

#### [Occurrence Conditions]

Floating-Point Exception (FPE) occurs when Unimplemented Exception (UIPL) or one of the five exceptions specified in IEEE 754 standards (OVF, UDF, IXCT, DIV0 or IVLD) is detected.

Note, however, that the EIT processing described below is executed only when the exception that occurred is one whose exception enable bit in the FPSR register is set to "1" or an unimplemented exception.

#### [EIT Processing]

##### (1) Saving SM, IE and C bits

The PSW register's SM, IE and C bits are saved to the respective backup bits: BSM, BIE and BC.

```
BSM ← SM
BIE ← IE
BC ← C
```

##### (2) Updating SM, IE and C bits

The PSW register's SM, IE and C bits are updated as shown below.

```
SM ← Unchanged
IE ← 0
C ← 0
```

**(3) Saving the PC**

The PC value of the instruction that generated the FPE + 4 is set in the BPC register.

Because all of the instructions that generate an FPE are 32 bits long, the address to which the RTE instruction returns is always the instruction next to the one that generated the FPE.

**(4) Branching to the EIT vector entry**

The CPU branches to the address H'0000 0090 in the user space. This is the last operation performed in hardware preprocessing.

**(5) Jumping from the EIT vector entry to the user-created handler**

The CPU executes the BRA instruction written by the user at the address H'0000 0090 of the EIT vector entry to jump to the start address of the user-created handler. At the beginning of the user-created EIT handler, first save the BPC, PSW and FPSR registers and the necessary general-purpose registers to the stack.

**(6) Returning from the EIT handler**

At the end of the EIT handler, restore the saved registers from the stack and execute the RTE instruction. When the RTE instruction is executed, hardware postprocessing is automatically performed.

## 4.9 Interrupt Processing

### 4.9.1 Reset Interrupt (RI)

#### [Occurrence Conditions]

A reset interrupt is accepted in machine cycle by pulling the RESET# input signal "L." The reset interrupt is assigned the highest priority among all EITs.

#### [EIT Processing]

##### (1) Initializing SM, IE and C bits

The PSW register's SM, IE and C bits are initialized as shown below.

SM	←	0
IE	←	0
C	←	0

For the reset interrupt, the values of BSM, BIE and BC bits are undefined.

##### (2) Branching to the EIT vector entry

The CPU branches to the address H'0000 0000 in the user space. However, when operating in boot mode, the CPU jumps to the boot program. For details, see Section 6.6, "Programming the Internal Flash Memory."

##### (3) Jumping from the EIT vector entry to the user program

The CPU executes the instruction written by the user at the address H'0000 0000 of the EIT vector entry. In the reset vector entry, be sure to initialize the PSW and SPI registers before jumping to the start address of the user program.

### 4.9.2 System Break Interrupt (SBI)

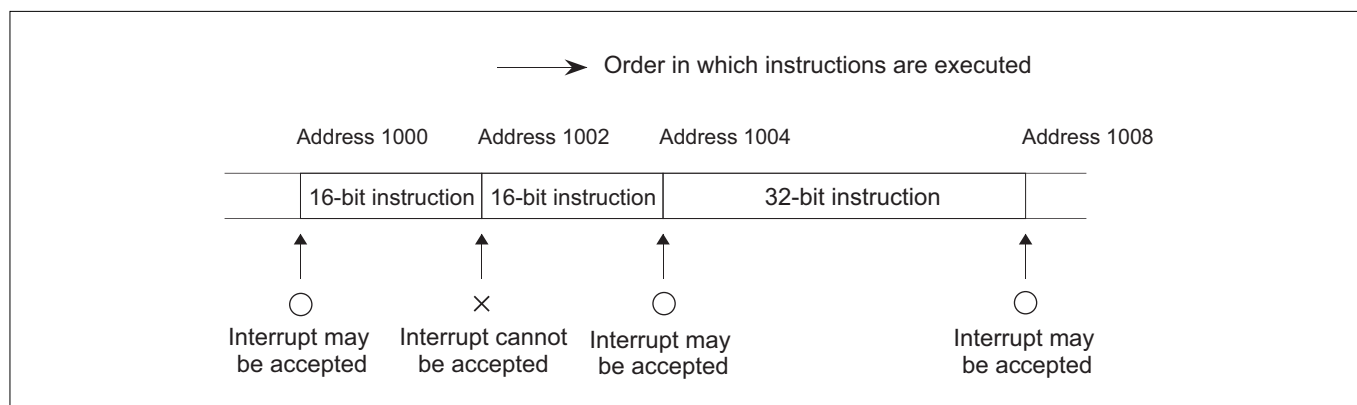
System Break Interrupt (SBI) is an emergency interrupt which is used when power outage is detected or a fault condition is notified by an external watchdog timer. The system break interrupt cannot be masked by the PSW register IE bit.

Therefore, the system break interrupt can only be used when the system has some fatal event already existing in it when the interrupt is detected. Also, this interrupt must be used on condition that after processing by the SBI handler, control will not return to the program that was being executed when the system break interrupt occurred.

#### [Occurrence Conditions]

A system break interrupt is accepted by a falling edge on SBI# input pin. (The system break interrupt cannot be masked by the PSW register IE bit.)

In no case will a system break interrupt be activated immediately after executing a 16-bit instruction that starts from a word boundary. (For 16-bit branch instructions, however, the interrupt is accepted immediately after branching.) Note also that because of the instruction processing-completed type, a system break interrupt is accepted after the instruction is completed.



**Figure 4.9.1 Timing at Which System Break Interrupt (SBI) is Accepted**

### [EIT Processing]

#### (1) Saving SM, IE and C bits

The PSW register's SM, IE and C bits are saved to the respective backup bits: BSM, BIE and BC.

```
BSM ← SM
BIE ← IE
BC ← C
```

#### (2) Updating SM, IE and C bits

The PSW register's SM, IE and C bits are updated as shown below.

```
SM ← 0
IE ← 0
C ← 0
```

#### (3) Saving the PC

The address of the next instruction (always on word boundary) following one in which the interrupt was detected is stored in the BPC register. If the interrupt was detected in a branch instruction, then the next instruction is one that exists at the jump address.

#### (4) Branching to the EIT vector entry

The CPU branches to the address H'0000 0010 in the user space. This is the last operation performed in hardware preprocessing.

#### (5) Jumping from the EIT vector entry to the user-created handler

The CPU executes the BRA instruction written by the user at the address H'0000 0010 of the EIT vector entry to jump to the start address of the user-created handler.

The system break interrupt can only be used when the system has some fatal event already existing in it when the interrupt is detected. Also, this interrupt must be used on condition that after processing by the SBI handler, control will not return to the program that was being executed when the system break interrupt occurred.

### 4.9.3 External Interrupt (EI)

An external interrupt is generated upon an interrupt request which is output by the microcomputer's internal interrupt controller. The interrupt controller manages interrupt requests by assigning each one of seven priority levels. For details, see Chapter 5, "Interrupt Controller." For details about the interrupt request sources, see each section in which the relevant internal peripheral I/O is described.

#### [Occurrence Conditions]

External interrupts are managed based on interrupt requests from each internal peripheral I/O by the microcomputer's internal interrupt controller, and are sent to the CPU via the interrupt controller. The CPU checks these interrupt requests at a break in instructions residing on word boundaries, and when an interrupt request is detected and the PSW register IE flag = "1", accepts it as an external interrupt.

In no case will an external interrupt be activated immediately after executing a 16-bit instruction that starts from a word boundary. (For 16-bit branch instructions, however, the interrupt is accepted immediately after branching.)

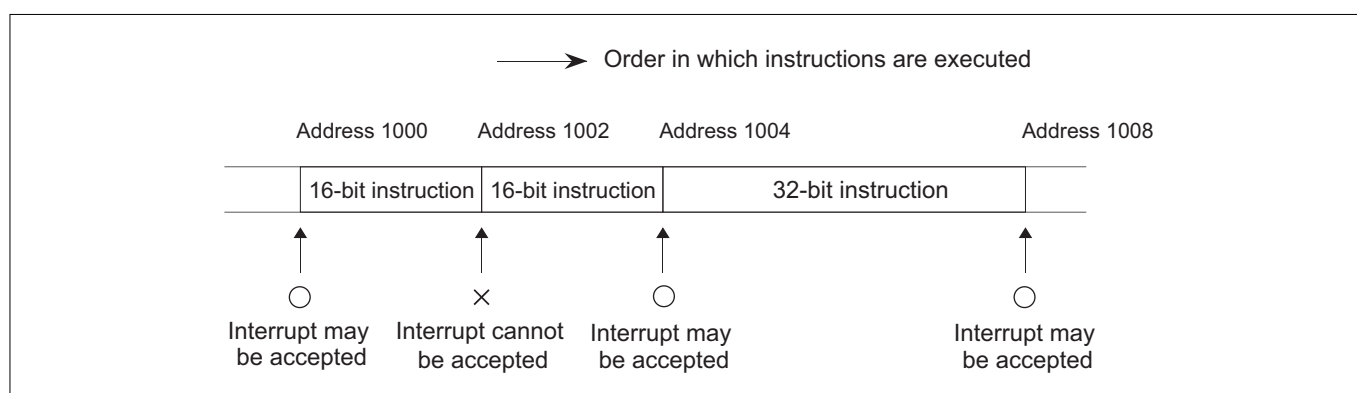


Figure 4.9.2 Timing at Which External Interrupt (EI) is Accepted

#### [EIT Processing]

##### (1) Saving SM, IE and C bits

The PSW register's SM, IE and C bits are saved to the respective backup bits: BSM, BIE and BC.

```
BSM ← SM
BIE ← IE
BC ← C
```

##### (2) Updating SM, IE and C bits

The PSW register's SM, IE and C bits are updated as shown below.

```
SM ← 0
IE ← 0
C ← 0
```

##### (3) Saving the PC

The content of the PC register (always on word boundary) is saved to the BPC register.

##### (4) Branching to the EIT vector entry

The CPU branches to the address H'0000 0080 in the user space. However, when operating in flash E/W enable mode, the CPU goes to the beginning of the internal RAM (address H'0080 4000). (For details, see Section 6.6, "Programming the Internal Flash Memory.") This is the last operation performed in hardware preprocessing.

##### (5) Jumping from the EIT vector entry to the user-created handler

The CPU executes the BRA instruction written by the user at the address H'0000 0080 of the EIT vector entry to jump to the start address of the user-created handler. At the beginning of the user-created EIT handler, first save the BPC and PSW registers and the necessary general-purpose registers to the stack. Also, save the accumulator and FPSR register as necessary.

**(6) Returning from the EIT handler**

At the end of the EIT handler, restore the saved registers from the stack and execute the RTE instruction. When the RTE instruction is executed, hardware postprocessing is automatically performed.

**4.10 Trap Processing****4.10.1 Trap****[Occurrence Conditions]**

Traps are software interrupts which are generated by executing the TRAP instruction. Sixteen traps are generated, each corresponding to one of TRAP instruction operands 0–15. Accordingly, sixteen vector entries are provided.

**[EIT Processing]****(1) Saving SM, IE and C bits**

The PSW register's SM, IE and C bits are saved to the respective backup bits: BSM, BIE and BC.

```
BSM ← SM
BIE ← IE
BC ← C
```

**(2) Updating SM, IE and C bits**

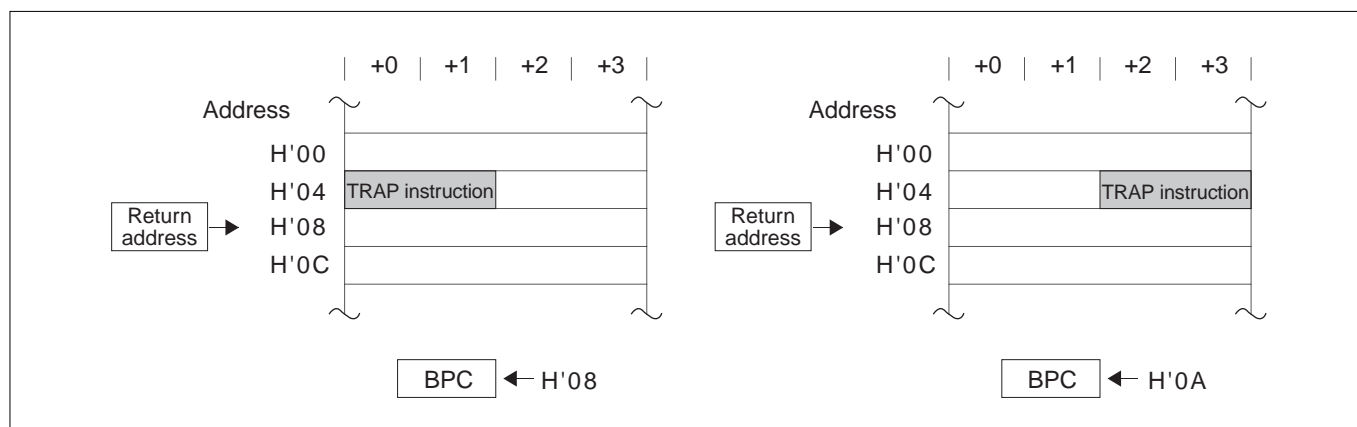
The PSW register's SM, IE and C bits are updated as shown below.

```
SM ← Unchanged
IE ← 0
C ← 0
```

**(3) Saving the PC**

When the trap instruction is executed, the PC value of TRAP instruction + 4 is set in the BPC register. For example, if the TRAP instruction is located at address 4, the value H'08 is set in the BPC register. Similarly, if the TRAP instruction is located at address 6, the value H'0A is set in the BPC register. The value of the BPC register bit 30 indicates whether the trap instruction resides on a word boundary (BPC register bit 30 = "0") or not on a word boundary (BPC register bit 30 = "1").

However, in either case of the above, the address to which the RTE instruction returns after the EIT handler has terminated is address 8. (This is because the 2 low-order address bits are cleared to '00' when returned to the PC.)



**Figure 4.10.1 Example of a Return Address for Trap (TRAP)**



**(4) Branching to the EIT vector entry**

The CPU branches to the addresses H'0000 0040–H'0000 007C in the user space. This is the last operation performed in hardware preprocessing.

**(5) Jumping from the EIT vector entry to the user-created handler**

The CPU executes the BRA instruction written by the user at the addresses H'0000 0040–H'0000 007C of the EIT vector entry to jump to the start address of the user-created handler. At the beginning of the user-created EIT handler, first save the BPC and PSW registers and the necessary general-purpose registers to the stack. Also, save the accumulator and FPSR register as necessary.

**(6) Returning from the EIT handler**

At the end of the EIT handler, restore the general-purpose registers and the BPC and PSW registers from the stack and execute the RTE instruction. When the RTE instruction is executed, hardware postprocessing is automatically performed. At this time, the CPU restarts from the next word-boundary instruction including the instruction that generates a trap (see Figure 4.10.1).

## 4.11 EIT Priority Levels

The table below lists the priority levels of EIT events. When two or more EITs occur simultaneously, the event with the highest priority is accepted first.

**Table 4.11.1 Priority of EIT Events and How Returned from EIT**

Priority	EIT Event	Type of Processing	Values Set in BPC Register	
Highest ↑	1	Reset Interrupt (RI)	Instruction processing-aborted type	Undefined
	2	Address Exception (AE)	Instruction processing-canceled type	PC of the instruction that generated AE
		Reserved Instruction Exception (RIE)	Instruction processing-canceled type	PC of the instruction that generated RIE
		Floating-Point Exception (FPE)	Instruction processing-completed type	PC of the instruction that generated FPE + 4
	3	Trap (TRAP)	Instruction processing-completed type	TRAP instruction + 4
Lowest ↓	3	System Break Interrupt (SBI)	Instruction processing-completed type	PC of the next instruction
	4	External Interrupt (EI)	Instruction processing-completed type	PC of the next instruction

Note that for External Interrupt (EI), the priority levels of interrupt requests from each peripheral I/O are set by the microcomputer's internal interrupt controller. For details, see Chapter 5, "Interrupt Controller."



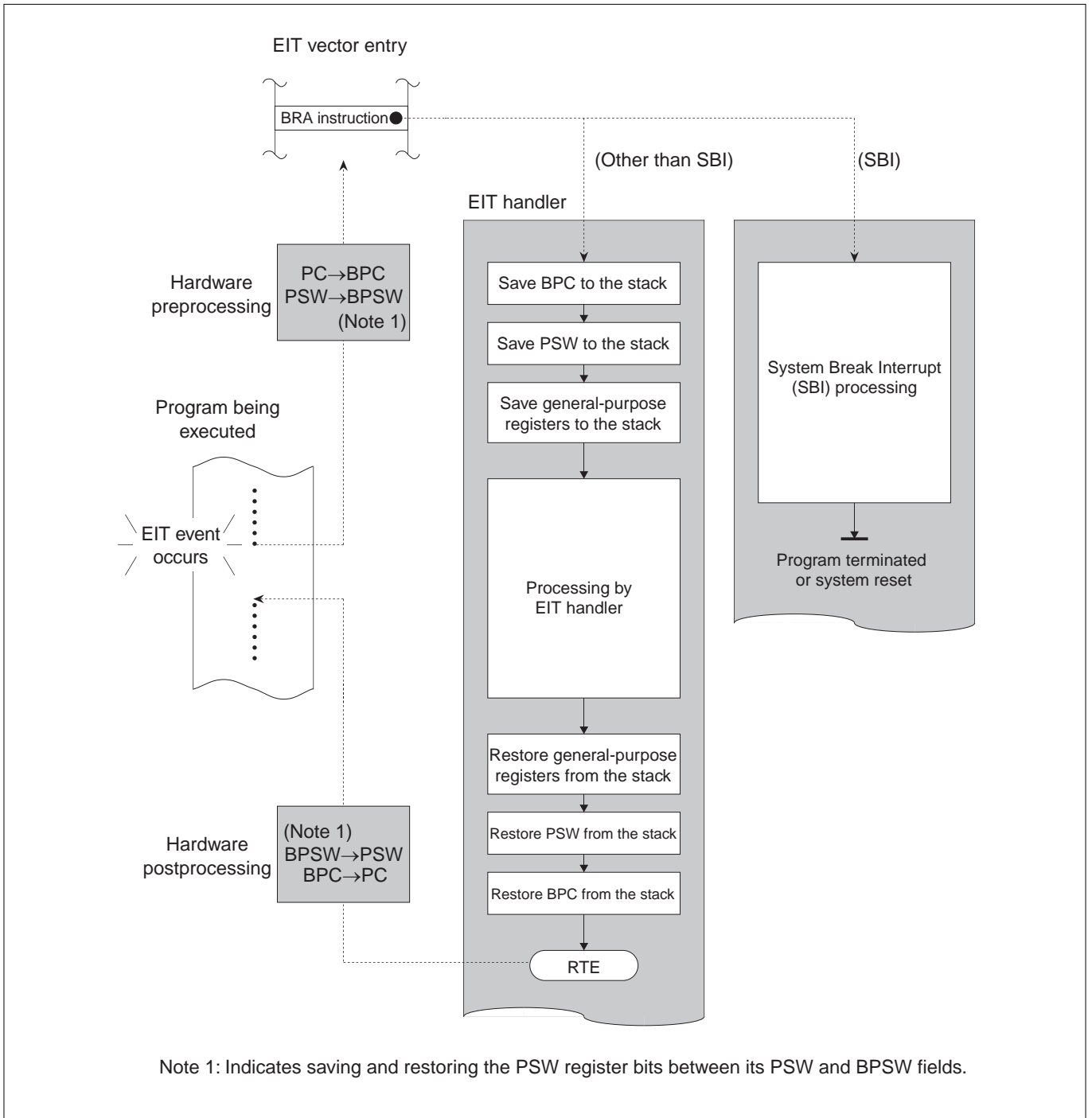


Figure 4.12.3 Example of EIT Processing

### 4.13 Notes on EIT

The Address Exception (AE) requires caution because if one of the instructions that use “register indirect + register update” addressing mode (following three) generates an address exception when it is executed, the values of the registers to be automatically updated (Rsrc and Rsrc2) become undefined.

Except that the values of Rsrc and Rsrc2 become undefined, these instructions behave the same way as when used in other addressing modes.

• **Applicable instructions**

LD	Rdest, @Rsrc+
ST	Rsrc1, @-Rsrc2
ST	Rsrc1, @+Rsrc2

If the above case applies, consider the fact that the register values become undefined when you design the processing to be performed after executing said instructions. (If an address exception occurs, it means that the system has some fatal fault already existing in it. Therefore, address exceptions must be used on condition that control will not be returned from the address exception handler to the program that was being executed when the exception occurred.)

## **CHAPTER 5**

---

# **INTERRUPT CONTROLLER (ICU)**

- 5.1 Outline of the Interrupt Controller
- 5.2 ICU Related Registers
- 5.3 Interrupt Request Sources in Internal Peripheral I/O
- 5.4 ICU Vector Table
- 5.5 Description of Interrupt Operation
- 5.6 Description of System Break Interrupt (SBI) Operation

## 5.1 Outline of the Interrupt Controller

The Interrupt Controller (ICU) manages maskable interrupts from internal peripheral I/Os and a system break interrupt (SBI). The maskable interrupts from internal peripheral I/Os are sent to the M32R CPU as external interrupts (EI).

The maskable interrupts from internal peripheral I/Os are managed by assigning them one of eight priority levels including an interrupt-disabled state. If two or more interrupt requests with the same priority level occur at the same time, their priorities are resolved by predetermined hardware priority. The source of an interrupt request generated in internal peripheral I/Os is identified by reading the relevant interrupt status register provided for internal peripheral I/Os.

On the other hand, the system break interrupt (SBI) is recognized when a low-going transition occurs on the SBI# signal input pin. This interrupt is used for emergency purposes such as when power outage is detected or a fault condition is notified by an external watchdog timer, so that it is always accepted irrespective of the PSW register IE bit status. When the CPU has finished servicing an SBI, shut down or reset the system without returning to the program that was being executed when the interrupt occurred.

Specifications of the Interrupt Controller are outlined below.

**Table 5.1.1 Outline of the Interrupt Controller (ICU)**

Item	Specification
Interrupt request source	Maskable interrupt requests from internal peripheral I/Os : 40 sources (Note 1)
	System break interrupt request : 1 source (entered from SBI# pin)
Priority management	8 priority levels including an interrupt-disabled state (However, interrupts with the same priority level have their priorities resolved by fixed hardware priority.)

Note 1: It is the number which summarized the number of interrupt requests for every group, and they are 257 factors as an interrupt request factor total.

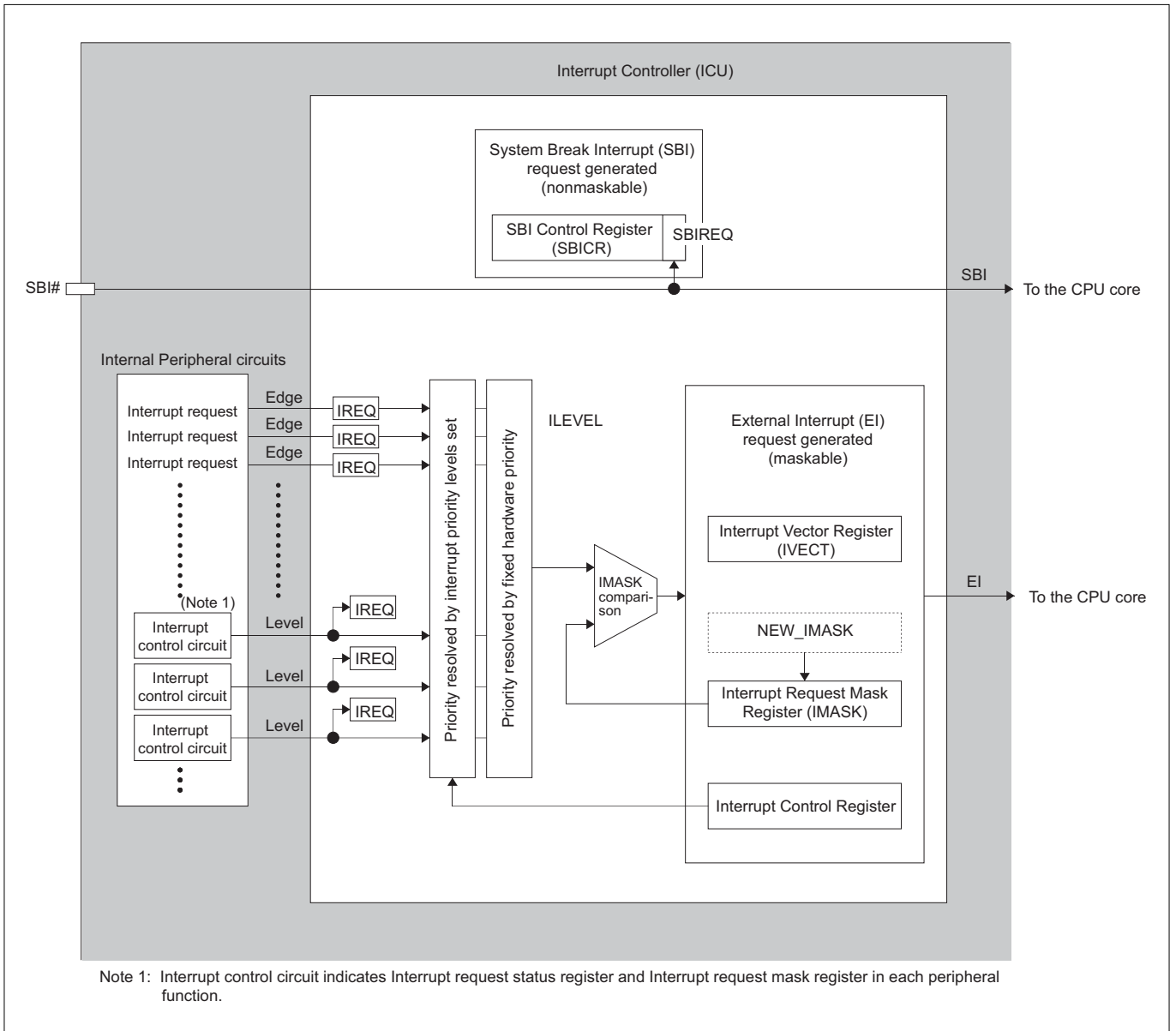


Figure 5.1.1 Block Diagram of the Interrupt Controller

## 5.2 ICU Related Registers

The diagram below shows a register Mask map associated with the Interrupt Controller (ICU).

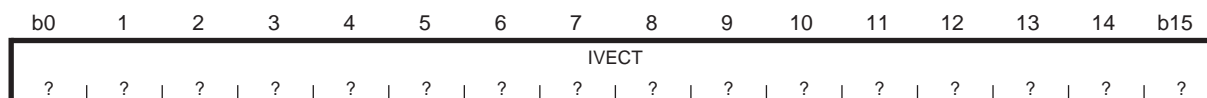
## ICU Related Register Map

Address	+0 address	+1 address	See pages
	b0	b7 b8	b15
H'0080 0000	Interrupt Vector Register (IVECT)		5-5
H'0080 0002	(Use inhibited area)		
H'0080 0004	Interrupt Request Mask Register (IMASK)	(Use inhibited area)	5-6
H'0080 0006	SBI Control Register (SBICR)	(Use inhibited area)	5-7
	(Use inhibited area)		
H'0080 0056	RAM Write Monitor Interrupt Control Register (IRAMWRCR)	CAN1 Error Interrupt Control Register (ICAN1ERCR)	5-8
H'0080 0058	CAN1 Single-Shot Interrupt Control Register (ICAN1SSCR)	CAN1 Transmit/Receive Interrupt Control Register (ICAN1TRCR)	5-8
H'0080 005A	CAN0 Error Interrupt Control Register (ICAN0ERCR)	CAN0 Single-Shot Interrupt Control Register (ICAN0SSCR)	5-8
H'0080 005C	CAN0 Transmit/Receive Interrupt Control Register (ICAN0TRCR)	DRI Event Detection Interrupt Control Register (IDRIEVCr)	5-8
H'0080 005E	DRI Counter Interrupt Control Register (IDRICNTR)	DRI Transfer Interrupt Control Register (IDRITR)	5-8
H'0080 0060	CAN0 Transmit/Receive & Error Interrupt Control Register (ICAN0CR)	TML1 Input Interrupt Control Register (ITML1CR)	5-8
H'0080 0062	(Use inhibited area)		
H'0080 0064	SIO4,5 Transmit/Receive Interrupt Control Register (ISIO45CR)	TOU1 Output Interrupt Control Register (ITOU1CR)	5-8
H'0080 0066	TID1 Output Interrupt Control Register (ITID1CR)	RTD Interrupt Control Register (IRTDCR)	5-8
H'0080 0068	SIO2,3 Transmit/Receive Interrupt Control Register (ISIO23CR)	DMA5–9 Interrupt Control Register (IDMA59CR)	5-8
H'0080 006A	TOU0 Output Interrupt Control Register (ITOU0CR)	TID0 Output Interrupt Control Register (ITID0CR)	5-8
H'0080 006C	A/D0 Conversion Interrupt Control Register (IAD0CCR)	SIO0 Transmit Interrupt Control Register (ISIO0TXCR)	5-8
H'0080 006E	SIO0 Receive Interrupt Control Register (ISIO0RXCR)	SIO1 Transmit Interrupt Control Register (ISIO1TXCR)	5-8
H'0080 0070	SIO1 Receive Interrupt Control Register (ISIO1RXCR)	DMA0–4 Interrupt Control Register (IDMA04CR)	5-8
H'0080 0072	MJT Output Interrupt Control Register 0 (IMJTOCR0)	MJT Output Interrupt Control Register 1 (IMJTOCR1)	5-8
H'0080 0074	MJT Output Interrupt Control Register 2 (IMJTOCR2)	MJT Output Interrupt Control Register 3 (IMJTOCR3)	5-8
H'0080 0076	MJT Output Interrupt Control Register 4 (IMJTOCR4)	MJT Output Interrupt Control Register 5 (IMJTOCR5)	5-8
H'0080 0078	MJT Output Interrupt Control Register 6 (IMJTOCR6)	MJT Output Interrupt Control Register 7 (IMJTOCR7)	5-8
H'0080 007A	MJT Input Interrupt Control Register 0 (IMJTICR0)	MJT Input Interrupt Control Register 1 (IMJTICR1)	5-8
H'0080 007C	MJT Input Interrupt Control Register 2 (IMJTICR2)	MJT Input Interrupt Control Register 3 (IMJTICR3)	5-8
H'0080 007E	MJT Input Interrupt Control Register 4 (IMJTICR4)	CAN1 Transmit/Receive & Error Interrupt Control Register (ICAN1CR)	5-8



## 5.2.1 Interrupt Vector Register

Interrupt Vector Register (IVECT) &lt;Address: H'0080 0000&gt;



&lt;Upon exiting reset: Undefined&gt;

b	Bit Name	Function	R	W
0–15	IVECT 16 low-order bits of ICU vector table address	When an interrupt request is accepted, the 16-low-order bits of the ICU vector table address for the accepted interrupt request source are stored in this register.	R	N

Note: • This register must always be accessed in halfwords (2 bytes). (This is a read-only register.)

The Interrupt Vector Register (IVECT) is used when an interrupt request is accepted to store the 16-low-order bits of the ICU vector table address for the accepted interrupt request source.

Before this function can work, the ICU vector table (addresses H'0000 0094 through H'0000 013B) must have set in it the start addresses of interrupt handlers for each internal peripheral I/O. When an interrupt request is accepted, the 16-low-order bits of the ICU vector table address for the accepted interrupt request source are stored in the IVECT register. In the EIT handler, read the content of this IVECT register using the LDH instruction to get the ICU vector table address.

When the IVECT register is read, operations (1) to (4) below are automatically performed in hardware.

- (1) The interrupt priority level of the accepted interrupt request source (ILEVEL) is set in the IMASK register as a new IMASK value. (Interrupts with lower priority levels than that of the accepted interrupt request source are masked.)
- (2) The interrupt request bit for the accepted interrupt request source is cleared (not cleared for level-recognized interrupt request sources).
- (3) The interrupt request (EI) to the CPU core is dropped.
- (4) The ICU's internal sequencer is activated to start internal processing (interrupt priority resolution).

Notes: • Do not read the Interrupt Vector Register (IVECT) in the EIT handler unless interrupts are disabled (PSW register IE bit = "0"). In the EIT handler, furthermore, read the Interrupt Request Mask Register (IMASK) first before reading the IVECT register.

- To reenabling interrupts (by setting the IE bit to "1") after reading the Interrupt Vector Register (IVECT), execute the following processing in the order given:

- (1) Read the Interrupt Vector Register (IVECT)
- (2) Perform a read access to the SFR at least once
- (3) Perform a dummy access to the internal memory, SFR, etc. at least once
- (4) Enable interrupts (by setting the IE bit to "1")

## 5.2.2 Interrupt Request Mask Register

Interrupt Request Mask Register (IMASK)

&lt;Address: H'0080 0004&gt;



&lt;Upon exiting reset: H'07&gt;

b	Bit Name	Function	R	W
0–4	No function assigned. Fix to "0"		0	0
5–7	IMASK Interrupt request mask bit	000: Disable maskable interrupts 001: Accept interrupts with priority level 0 010: Accept interrupts with priority levels 0–1 011: Accept interrupts with priority levels 0–2 100: Accept interrupts with priority levels 0–3 101: Accept interrupts with priority levels 0–4 110: Accept interrupts with priority levels 0–5 111: Accept interrupts with priority levels 0–6	R	W

The Interrupt Request Mask Register (IMASK) is used to finally determine whether or not to accept an interrupt request after comparing its priority with the priority levels (Interrupt Control Register ILEVEL bits) that have been set for each interrupt request source.

When the Interrupt Vector Register (IVECT) is read, the interrupt priority level of the accepted interrupt request source is set in this IMASK register as a new mask value.

When any value is written to the IMASK register, operations (1) to (2) below are automatically performed in hardware.

- (1) The interrupt request (EI) to the CPU core is deasserted.
- (2) The ICU's internal sequencer is activated to start internal processing (interrupt priority resolution).

- Notes:
- Do not write to the Interrupt Request Mask Register (IMASK) unless interrupts are disabled (PSW register IE bit = "0").
  - To reenale interrupts (by setting the IE bit to "1") after writing to the Interrupt Request Mask Register (IMASK), execute the following processing in the order given:

- (1) Write to the Interrupt Request Mask Register (IMASK)
- (2) Perform a read access to the SFR at least once
- (3) Perform a dummy access to the internal memory, SFR, etc. at least once
- (4) Enable interrupts (by setting the IE bit to "1")

or

- (1) Write to the Interrupt Request Mask Register (IMASK)
- (2) Perform a dummy access to the internal memory, SFR, etc. twice or more
- (3) Issue four or more instructions (Note 1)
- (4) Enable interrupts (by setting the IE bit to "1")

Note 1: Any instructions other than NOP that does not require clock cycles (one that is automatically inserted by the assembler for alignment adjustment: instruction code H'F000)

### 5.2.3 SBI (System Break Interrupt) Control Register

SBI (System Break Interrupt) Control Register (SBICR)

<Address: H'0080 0006>

b0	1	2	3	4	5	6	b7
0	0	0	0	0	0	0	SBIREQ 0

<Upon exiting reset: H'00>

b	Bit Name	Function	R	W
0–6	No function assigned. Fix to "0"		0	0
7	SBIREQ	0: SBI not requested	R (Note 1)	
	SBI request bit	1: SBI requested		

Note 1: This bit can only be cleared (see below)

The System Break Interrupt (SBI) is an interrupt request generated by a falling edge on the SBI# signal input pin.

When a falling edge on the SBI# signal input pin is detected and this bit is set to "1", a system break interrupt (SBI) request is generated to the CPU.

This bit cannot be set to "1" in software, it can only be cleared.

To clear this bit to "0", follow the procedure described below.

1. Write "1" to the SBI request bit.
2. Write "0" to the SBI request bit.

- Notes:
- Unless this bit is set to "1", do not perform the above clearing operation.
  - If falling edge is inputted to SBI# pin again, system break is not occurred while SBI request bit is set to "1."

### 5.2.4 Interrupt Control Registers

RAM Write Monitor Interrupt Control Register (IRAMWRCR)	<Address: H'0080 0056>
CAN1 Error Interrupt Control Register (ICAN1ERCR)	<Address: H'0080 0057>
CAN1 Single-Shot Interrupt Control Register (ICAN1SSCR)	<Address: H'0080 0058>
CAN1 Transmit/Receive Interrupt Control Register (ICAN1TRCR)	<Address: H'0080 0059>
CAN0 Error Interrupt Control Register (ICAN0ERCR)	<Address: H'0080 005A>
CAN0 Single-Shot Interrupt Control Register (ICAN0SSCR)	<Address: H'0080 005B>
CAN0 Transmit/Receive Interrupt Control Register (ICAN0TRCR)	<Address: H'0080 005C>
DRI Event Detection Interrupt Control Register (IDRIEVCr)	<Address: H'0080 005D>
DRI Counter Interrupt Control Register (IDRICNTR)	<Address: H'0080 005E>
DRI Transfer Interrupt Control Register (IDRITRCR)	<Address: H'0080 005F>
CAN0 Transmit/Receive & Error Interrupt Control Register (ICAN0CR)	<Address: H'0080 0060>
TML1 Input Interrupt Control Register (ITML1CR)	<Address: H'0080 0061>
SIO4,5 Transmit/Receive Interrupt Control Register (ISIO45CR)	<Address: H'0080 0064>
TOU1 Output Interrupt Control Register (ITOU1CR)	<Address: H'0080 0065>
TID1 Output Interrupt Control Register (ITID1CR)	<Address: H'0080 0066>
RTD Interrupt Control Register (IRTDCR)	<Address: H'0080 0067>
SIO2,3 Transmit/Receive Interrupt Control Register (ISIO23CR)	<Address: H'0080 0068>
DMA5–9 Interrupt Control Register (IDMA59CR)	<Address: H'0080 0069>
TOU0 Output Interrupt Control Register (ITOU0CR)	<Address: H'0080 006A>
TID0 Output Interrupt Control Register (ITID0CR)	<Address: H'0080 006B>
A/D0 Conversion Interrupt Control Register (IAD0CCR)	<Address: H'0080 006C>
SIO0 Transmit Interrupt Control Register (ISIO0TXCR)	<Address: H'0080 006D>
SIO0 Receive Interrupt Control Register (ISIO0RXCR)	<Address: H'0080 006E>
SIO1 Transmit Interrupt Control Register (ISIO1TXCR)	<Address: H'0080 006F>
SIO1 Receive Interrupt Control Register (ISIO1RXCR)	<Address: H'0080 0070>
DMA0–4 Interrupt Control Register (IDMA04CR)	<Address: H'0080 0071>
MJT Output Interrupt Control Register 0 (IMJTOCR0)	<Address: H'0080 0072>
MJT Output Interrupt Control Register 1 (IMJTOCR1)	<Address: H'0080 0073>
MJT Output Interrupt Control Register 2 (IMJTOCR2)	<Address: H'0080 0074>
MJT Output Interrupt Control Register 3 (IMJTOCR3)	<Address: H'0080 0075>
MJT Output Interrupt Control Register 4 (IMJTOCR4)	<Address: H'0080 0076>
MJT Output Interrupt Control Register 5 (IMJTOCR5)	<Address: H'0080 0077>
MJT Output Interrupt Control Register 6 (IMJTOCR6)	<Address: H'0080 0078>
MJT Output Interrupt Control Register 7 (IMJTOCR7)	<Address: H'0080 0079>
MJT Input Interrupt Control Register 0 (IMJTICR0)	<Address: H'0080 007A>
MJT Input Interrupt Control Register 1 (IMJTICR1)	<Address: H'0080 007B>
MJT Input Interrupt Control Register 2 (IMJTICR2)	<Address: H'0080 007C>
MJT Input Interrupt Control Register 3 (IMJTICR3)	<Address: H'0080 007D>
MJT Input Interrupt Control Register 4 (IMJTICR4)	<Address: H'0080 007E>
CAN1 Transmit/Receive & Error Interrupt Control Register (ICAN1CR)	<Address: H'0080 007F>

b0	1	2	3	4	5	6	b7
(b8)	9	10	11	12	13	14	b15)
0			IREQ	0	ILEVEL		
0			0	0	1		

&lt;Upon exiting reset: H'07&gt;

b	Bit Name	Function	R	W
0–2 (8–10)	No function assigned. Fix to "0"		0	0
3 (11)	IREQ Interrupt request bit	<When edge-recognized> At read 0: Interrupt not requested 1: Interrupt requested At write 0: Clear interrupt request 1: Generate interrupt request	R	W
4 (12)	No function assigned. Fix to "0"	<When level-recognized> At read 0: Interrupt not requested 1: Interrupt requested	R	0
5–7 (13–15)	ILEVEL Interrupt priority level bits	000: Interrupt priority level 0 001: Interrupt priority level 1 010: Interrupt priority level 2 011: Interrupt priority level 3 100: Interrupt priority level 4 101: Interrupt priority level 5 110: Interrupt priority level 6 111: Interrupt priority level 7 (interrupt disabled)	R	W

**(1) IREQ (Interrupt Request) bit (Bit 3 or 11)**

When an interrupt request from some internal peripheral I/O occurs, the corresponding IREQ (Interrupt Request) bit is set to "1."

This bit can be set and cleared in software for only edge-recognized interrupt request sources (and not for level-recognized interrupt request sources). Also, when this bit is set by an edge-recognized interrupt request generated, it is automatically cleared to "0" by reading the Interrupt Vector Register (IVECT) (not cleared in the case of level-recognized interrupt request).

If the IREQ bit is cleared in software at the same time it is set by an interrupt request generated, clearing in software has priority. Also, if the IREQ bit is cleared by reading the Interrupt Vector Register (IVECT) at the same time it is set by an interrupt request generated, clearing by a read of the IVECT register has priority.

Note: • External Interrupt (EI) to the CPU core is not deasserted by clearing the IREQ bit. External Interrupt (EI) to the CPU core can only be deasserted by the following operation:

- (1) Reset
- (2) IVECT register read
- (3) Write to the IMASK register

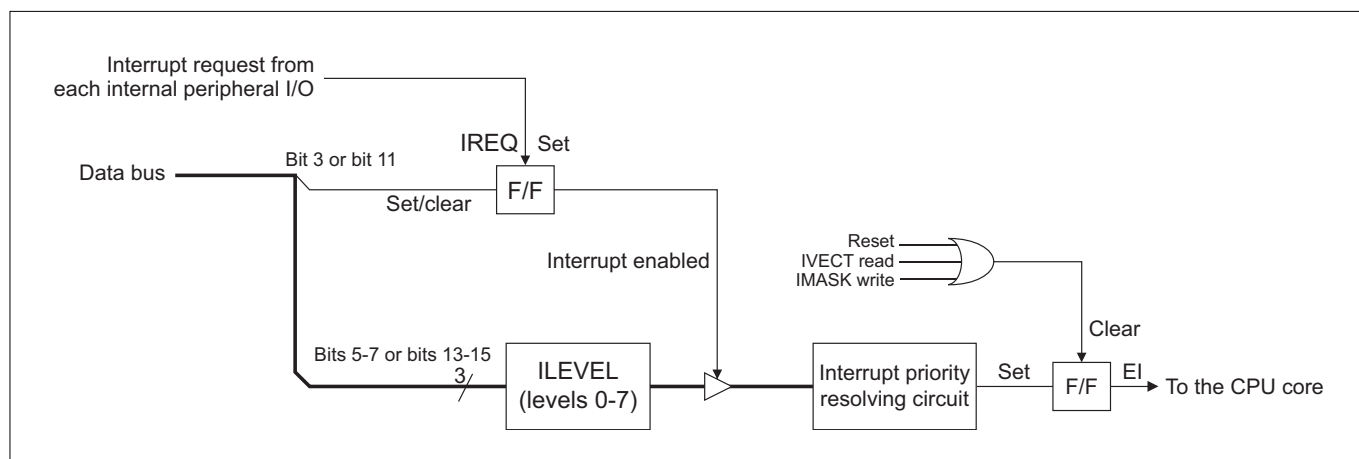


Figure 5.2.1 Configuration of the Interrupt Control Register (Edge-recognized Type)

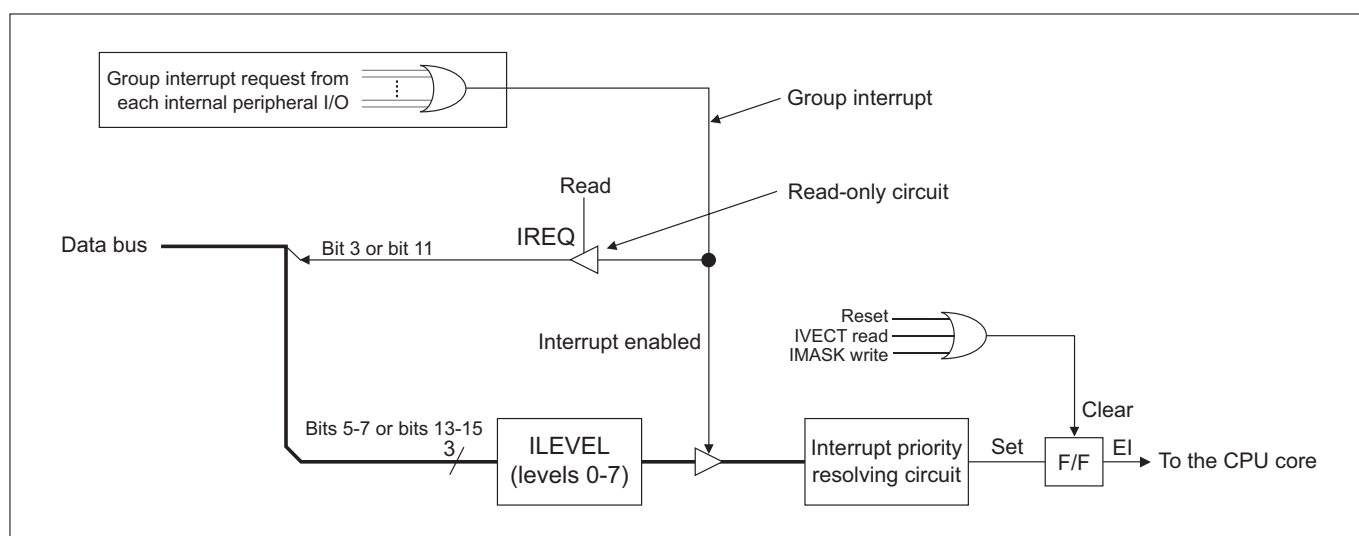


Figure 5.2.2 Configuration of the Interrupt Control Register (Level-recognized Type)

### (2) ILEVEL (Interrupt Priority Level) (Bits 5–7 or bits 13–15)

These bits set the priority levels of interrupt requests from each internal peripheral I/O. Set these bits to '111' to disable or any value '000' through '110' to enable the interrupt from some internal peripheral I/O.

When an interrupt occurs, the Interrupt Controller resolves priority between this interrupt and other interrupt sources based on ILEVEL settings and finally compares priority with the IMASK value to determine whether to forward an EI request to the CPU or keep the interrupt request pending.

The table below shows the relationship between ILEVEL settings and the IMASK values at which interrupts are accepted.

Table 5.2.1 ILEVEL Settings and Accepted IMASK Values

ILEVEL values set	IMASK values at which interrupts are accepted
0 (ILEVEL = "000")	Accepted when IMASK is 1–7
1 (ILEVEL = "001")	Accepted when IMASK is 2–7
2 (ILEVEL = "010")	Accepted when IMASK is 3–7
3 (ILEVEL = "011")	Accepted when IMASK is 4–7
4 (ILEVEL = "100")	Accepted when IMASK is 5–7
5 (ILEVEL = "101")	Accepted when IMASK is 6–7
6 (ILEVEL = "110")	Accepted when IMASK is 7
7 (ILEVEL = "111")	Not accepted (interrupts disabled)

### 5.3 Interrupt Request Sources in Internal Peripheral I/O

The Interrupt Controller receives as inputs the interrupt requests from MJT (multijunction timer), DMAC, serial interface, A/D converter, RTD, CAN, DRI and RAM write monitor. For details about these interrupts, see each section in which the relevant internal peripheral I/O is described.

**Table 5.3.1 Interrupt Request Sources in Internal Peripheral I/O**

Interrupt Request Sources	Contents	Number of Input Sources	ICU Type of Input Source (Note 1)
MJT input interrupt 4	MJT input interrupt group 4 (TIN3–TIN6 inputs)	4	Level-recognized
MJT input interrupt 3	MJT input interrupt group 3 (TIN20–TIN27 inputs)	8	Level-recognized
MJT input interrupt 2	MJT input interrupt group 2 (TIN16–TIN19 inputs)	4	Level-recognized
MJT input interrupt 1	MJT input interrupt group 1 (TIN0 input)	1	Level-recognized
MJT input interrupt 0	MJT input interrupt group 0 (TIN7–TIN11 inputs)	5	Level-recognized
MJT output interrupt 7	MJT output interrupt group 7 (TMS0, TMS1 output)	2	Level-recognized
MJT output interrupt 6	MJT output interrupt group 6 (TOP8, TOP9 output)	2	Level-recognized
MJT output interrupt 5	MJT output interrupt group 5 (TOP10 output)	1	Edge-recognized
MJT output interrupt 4	MJT output interrupt group 4 (TIO4–TIO7 outputs)	4	Level-recognized
MJT output interrupt 3	MJT output interrupt group 3 (TIO8, TIO9 outputs)	2	Level-recognized
MJT output interrupt 2	MJT output interrupt group 2 (TOP0–TOP5 outputs)	6	Level-recognized
MJT output interrupt 1	MJT output interrupt group 1 (TOP6, TOP7 outputs)	2	Level-recognized
MJT output interrupt 0	MJT output interrupt group 0 (TIO0–TIO3 outputs)	4	Level-recognized
DMA0–4 interrupt	DMA0–4 transfer-completed	5	Level-recognized
SIO1 receive interrupt	SIO1 reception-completed or receive error interrupt	1	Edge-recognized
SIO1 transmit interrupt	SIO1 transmission-completed or transmit buffer empty interrupt	1	Edge-recognized
SIO0 receive interrupt	SIO0 reception-completed or receive error interrupt	1	Edge-recognized
SIO0 transmit interrupt	SIO0 transmission-completed or transmit buffer empty interrupt	1	Edge-recognized
A/D0 conversion interrupt	A/D0 conversion (single mode, scan single-shot mode, or 1 cycle of scan continuous mode) completed and compare-completed	1	Edge-recognized
TID0 output interrupt	TID0 output	1	Edge-recognized
TOU0 output interrupt	TOU0_0–TOU0_7 outputs	8	Level-recognized
DMA5–9 interrupt	DMA5–9 transfer-completed	5	Level-recognized
SIO2,3 transmit/receive interrupt	SIO2,3 reception-completed or receive error interrupt, transmission-completed or transmit buffer empty interrupt	4	Level-recognized
RTD interrupt	RTD interrupt generation command	1	Edge-recognized
TID1 output interrupt	TID1 output	1	Edge-recognized
TOU1 output interrupt	TOU1_0–TOU1_7 outputs	8	Level-recognized
SIO4,5 transmit/receive interrupt	SIO4,5 reception-completed or receive error interrupt, transmission-completed or transmit buffer empty interrupt	4	Level-recognized
TML1 input interrupt	TML1 input (TIN30–TIN33 inputs)	4	Level-recognized
CAN0 transmit/receive & error interrupt	CAN0 transmission or reception completed, CAN0 bus error, CAN0 error passive, CAN0 bus-off, CAN0 single-shot	67	Level-recognized
CAN1 transmit/receive & error interrupt	CAN1 transmission or reception completed, CAN1 bus error, CAN1 error passive, CAN1 bus-off, CAN1 single-shot	67	Level-recognized
DRI transfer interrupt	DRI address counter 0 transfer-completed, DRI address counter 1 transfer-completed, overrun error, latch enable error and DRI transfer counter underflow	5	Level-recognized
DRI counter interrupt	DEC0–DEC4 underflow	5	Level-recognized
DRI event detection interrupt	DIN0–DIN5 event detected	6	Level-recognized
CAN0 transmit/receive interrupt	CAN0 transmission-completed, CAN0 reception-completed	32	Level-recognized
CAN0 single-shot interrupt	CAN0 single-shot	32	Level-recognized
CAN0 error interrupt	CAN0 bus error, CAN0 error passive, CAN0 bus off	3	Level-recognized
CAN1 transmit/receive interrupt	CAN1 transmission-completed, CAN1 reception-completed	32	Level-recognized
CAN1 single-shot interrupt	CAN1 single-shot	32	Level-recognized
CAN1 error interrupt	CAN1 bus error, CAN1 error passive, CAN1 bus off	3	Level-recognized
RAM write monitor interrupt	RAM write	16	Level-recognized

Note 1: ICU type of input source

- Edge-recognized: Interrupt requests are generated on a falling edge of the interrupt signal supplied to the ICU.
- Level-recognized: Interrupt requests are generated when the interrupt signal supplied to the ICU is held "L." For this type of interrupt, the ICU's Interrupt Control Register IRQ bit cannot be set or cleared in software.







## 5.5 Description of Interrupt Operation

### 5.5.1 Acceptance of Internal Peripheral I/O Interrupts

An interrupt request from any internal peripheral I/O is checked to see whether or not to accept by comparing its ILEVEL value set in the Interrupt Control Register and the IMASK value of the Interrupt Request Mask Register. If its priority is higher than the IMASK value, the interrupt request is accepted. However, if two or more interrupt requests occur simultaneously, the Interrupt Controller resolves priority between these interrupt requests following the procedure described below.

- 1) The ILEVEL values set in the Interrupt Control Registers for the respective internal peripheral I/Os are compared with each other.
- 2) If the ILEVEL values are the same, priorities are resolved according to the predetermined hardware priority.
- 3) The ILEVEL and IMASK values are compared.

If two or more interrupt requests occur simultaneously, the Interrupt Controller first compares their priority levels set in each Interrupt Control Register's ILEVEL bit to select an interrupt request that has the highest priority. If the interrupt requests have the same ILEVEL value, their priorities are resolved according to the hardware fixed priority. The interrupt request thus selected has its ILEVEL value compared with the IMASK value and if its priority is higher than the IMASK value, the Interrupt Controller sends an EI request to the CPU.

Interrupt requests may be masked by setting the Interrupt Request Mask Register and the Interrupt Control Register's ILEVEL bit (disabled at level 7) provided for each internal peripheral I/O and the PSW register IE bit.

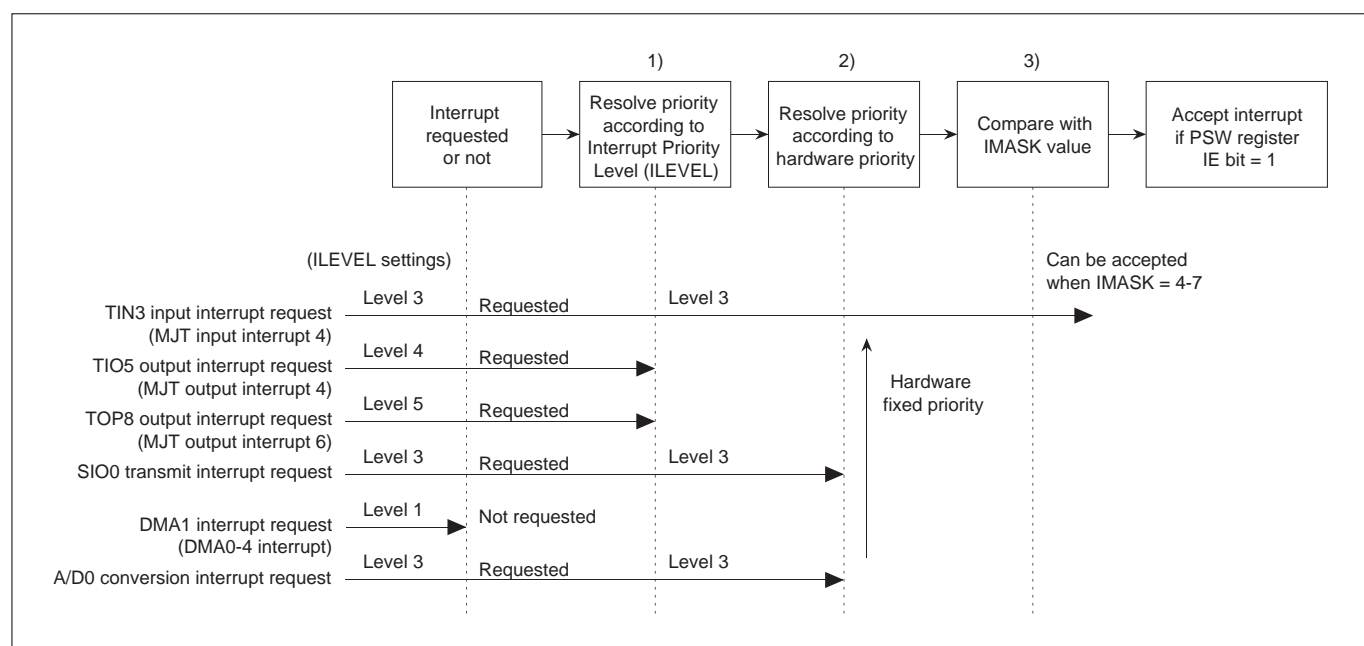


Figure 5.5.1 Example of Priority Resolution when Accepting Interrupt Requests

Table 5.5.1 ILEVEL Settings and Accepted IMASK Values

ILEVEL values set	IMASK values at which interrupts are accepted
0 (ILEVEL = "000")	Accepted when IMASK is 1-7
1 (ILEVEL = "001")	Accepted when IMASK is 2-7
2 (ILEVEL = "010")	Accepted when IMASK is 3-7
3 (ILEVEL = "011")	Accepted when IMASK is 4-7
4 (ILEVEL = "100")	Accepted when IMASK is 5-7
5 (ILEVEL = "101")	Accepted when IMASK is 6-7
6 (ILEVEL = "110")	Accepted when IMASK is 7
7 (ILEVEL = "111")	Not accepted (interrupts disabled)

## 5.5.2 Processing by Internal Peripheral I/O Interrupt Handlers

### (1) Branching to the interrupt handler

Upon accepting an interrupt request, the CPU branches to the EIT vector entry after performing the hardware preprocessing as described in Section 4.3, "EIT Processing Procedure." The EIT vector entry for External Interrupt (EI) is located at the address H'0000 0080. This address is where the instruction (not the jump address itself) for branching to the beginning of the interrupt handler routine for external interrupt requests is written.

### (2) Processing in the External Interrupt (EI) handler

A typical operation of the External Interrupt (EI) handler (for interrupts from internal peripheral I/O) is shown in Figure 5.5.2.

#### [1] Saving each register to the stack

Save the BPC, PSW and general-purpose registers to the stack. Also, save the accumulator and FPSR register to the stack as necessary.

#### [2] Reading the Interrupt Request Mask Register (IMASK) and saving to the stack

Read the Interrupt Request Mask Register and save its content to the stack.

#### [3] Reading the Interrupt Vector Register (IVECT)

Read the Interrupt Vector Register. This register holds the 16 low-order address bits of the ICU vector table for the accepted interrupt request source that was stored in it when accepting an interrupt request. When the Interrupt Vector Register is read, the following processing is automatically performed in hardware:

- The interrupt priority level of the accepted interrupt request (ILEVEL) is set in the IMASK register as a new IMASK value. (Interrupts with lower priority levels than that of the accepted interrupt request source are masked.)
- The accepted interrupt request source is cleared (not cleared for level-recognized interrupt request sources).
- The interrupt request (EI) to the CPU core is dropped.
- The ICU's internal sequencer is activated to start internal processing (interrupt priority resolution).

#### [4] Reading and overwriting the Interrupt Request Mask Register (IMASK)

Read the Interrupt Request Mask Register and overwrite it with the read value. This write to the IMASK register causes the following processing to be automatically performed in hardware:

- The interrupt request (EI) to the CPU core is dropped.
- The ICU's internal sequencer is activated to start internal processing (interrupt priority resolution).

#### [5] Reading the ICU vector table

Read the ICU vector table for the accepted interrupt request source. The relevant ICU vector table address can be obtained by zero-extending the content of the Interrupt Vector Register that was read in [3] (i.e., the 16 low-order address bits of the ICU vector table for the accepted interrupt request source). The ICU vector table must have set in it the start address of the interrupt handler for the interrupt request source concerned.)

#### [6] Enabling multiple interrupts

To enable another higher priority interrupt while processing the accepted interrupt (i.e., enabling multiple interrupts), set the PSW register IE bit to "1."

Notes: • There are precautions to be taken when reenabling interrupts (by setting the IE bit to "1") after reading the Interrupt Vector Register (IVECT). For details, see the Section 5.2.1, "Interrupt Vector Register (IVECT)." The precautions apply to the Process [4], therefore, other processes are not required to add.

- There are precautions to be taken when reenabling interrupts (by setting the IE bit to "1") after writing to the Interrupt Request Mask Register (IMASK). For details, see the Section 5.2.2, "Interrupt Request Mask Register (IMASK)."

**[7] Branching to the internal peripheral I/O interrupt handler**

Branch to the start address of the interrupt handler that was read out in [5].

**[8] Processing in the internal peripheral I/O interrupt handler****[9] Disabling interrupts**

Clear the PSW register IE bit to "0" to disable interrupts.

**[10] Restoring the Interrupt Request Mask Register (IMASK)**

Restore the Interrupt Request Mask Register that was saved to the stack in [2].

**[11] Restoring registers from the stack**

Restore the registers that were saved to the stack in [1].

**[12] Completion of external interrupt processing**

Execute the RTE instruction to complete the external interrupt processing. The program returns to the state in which it was before the interrupt request currently being processed was accepted.

**(3) Identifying the source of the interrupt request generated**

If any internal peripheral I/O has two or more interrupt request sources, check the Interrupt Request Status Register provided for each internal peripheral I/O to identify the source of the interrupt request generated.

**(4) Enabling multiple interrupts**

To enable multiple interrupts in the interrupt handler, set the PSW register IE (Interrupt Enable) bit to enable interrupt requests to be accepted. However, before writing "1" to the IE bit, be sure to save each register (BPC, PSW, general-purpose registers and IMASK) to the stack.

Note: • Before enabling multiple interrupts, read the Interrupt Vector Register (IVECT) and then the ICU vector table, as shown in Figure 5.5.2, "Typical Handler Operation for Interrupts from Internal Peripheral I/O."

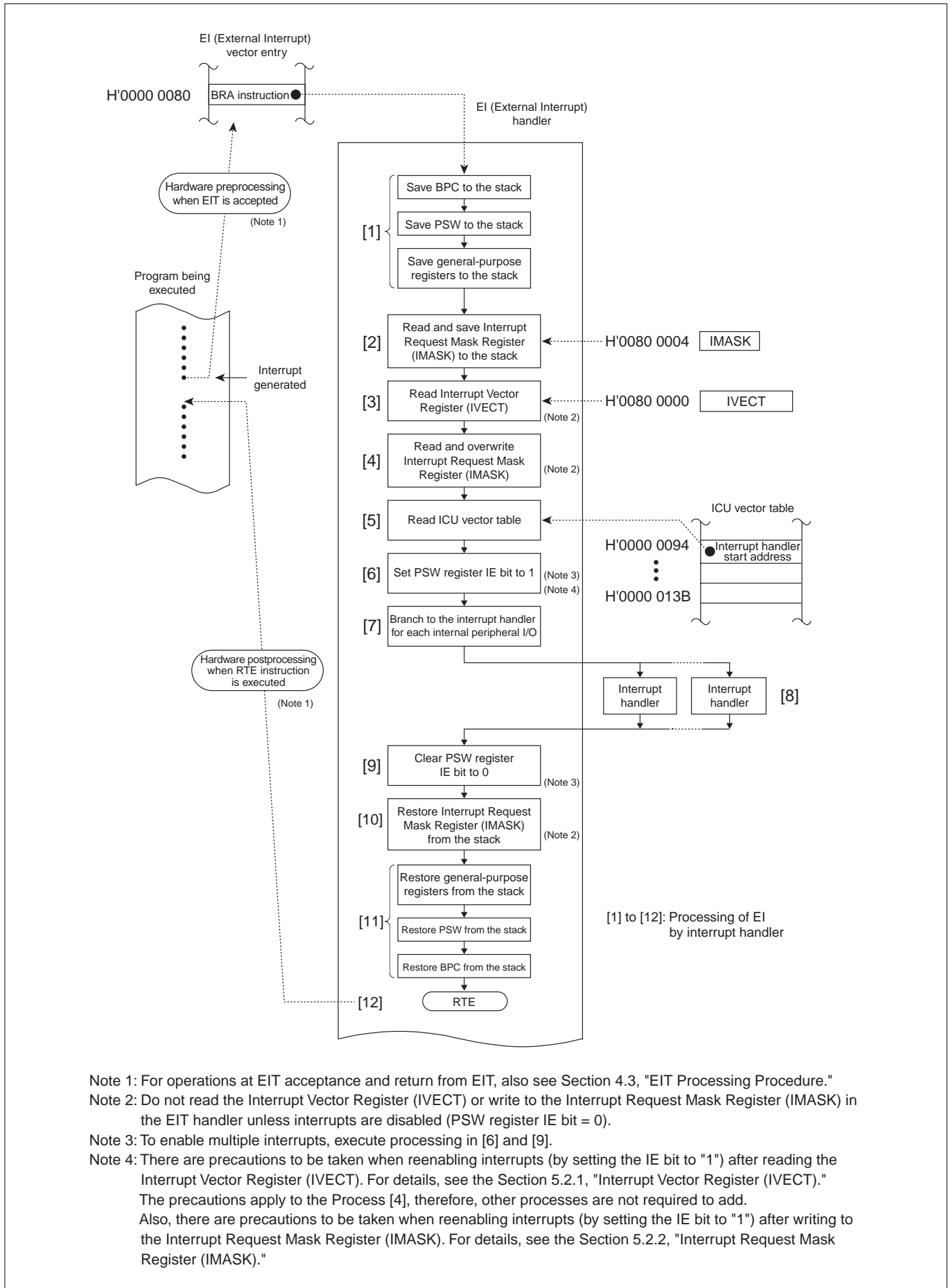


Figure 5.5.2 Typical Handler Operation for Interrupts from Internal Peripheral I/O

## 5.6 Description of System Break Interrupt (SBI) Operation

### 5.6.1 Acceptance of SBI

System Break Interrupt (SBI) is an emergency interrupt which is used when power outage is detected or a fault condition is notified by an external watchdog timer. The system break interrupt is accepted anytime upon detection of a falling edge on the SBI# signal input pin no matter how the PSW register IE bit is set, and cannot be masked. If falling edge is inputted to SBI# pin again, system break is not occurred while SBI request bit is set to "1."

### 5.6.2 SBI Processing by Handler

When the system break interrupt generated has been serviced, shut down or reset the system without returning to the program that was being executed when the interrupt occurred.

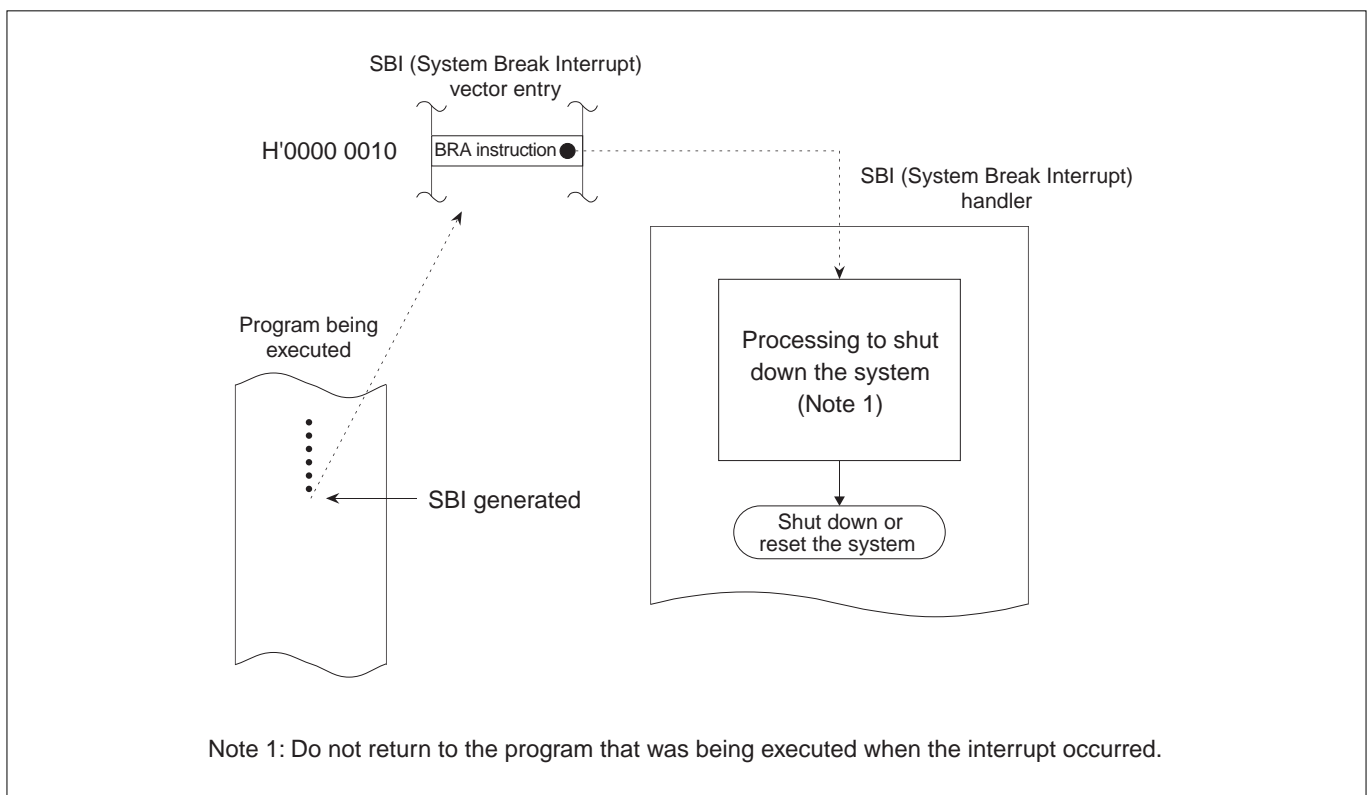


Figure 5.6.1 Typical SBI Operation

This page is blank for reasons of layout.

## CHAPTER 6

---

# INTERNAL MEMORY

- 6.1 Outline of the Internal Memory
- 6.2 Internal RAM
- 6.3 Internal RAM Protect Function
- 6.4 Internal Flash Memory
- 6.5 Registers Associated with the Internal Flash Memory
- 6.6 Programming the Internal Flash Memory
- 6.7 Virtual Flash Emulation Function
- 6.8 Connecting to A Serial Programmer (CSIO Mode)
- 6.9 Connecting to A Serial Programmer (UART Mode)
- 6.10 Internal Flash Memory Protect Function
- 6.11 Notes on the Internal RAM
- 6.12 Notes on the Internal Flash Memory

## 6.1 Outline of the Internal Memory

The 32192/32195/32196 internally contains the following types of memory:

- 176-Kbyte, 32-Kbyte, 64-Kbyte RAM
- 1-Mbyte (1024 Kbytes) and 512-Kbyte flash memory

## 6.2 Internal RAM

Specifications of the internal RAM are shown below.

**Table 6.2.1 Specifications of the Internal RAM**

Item	Specification
Size	M32192F8 : 176 Kbytes M32195F4 : 32 Kbytes M32196F8 : 64 Kbytes
Location address	M32192F8 : H'0080 4000 to H'0082 FFFF M32195F4 : H'0080 4000 to H'0080 BFFF M32196F8 : H'0080 4000 to H'0081 3FFF
Wait insertion	Operates with zero wait states
Internal bus connection	Connected by 32-bit bus
Dual port	By using the Real-Time Debugger (RTD), data can be read (monitored) or written to any area of the internal RAM via serial communication from external devices independently of the CPU. (See Chapter 15, "Real-Time Debugger.")

Note: • The value of RAM is undefined immediately after reset is deasserted during power-on (the power-on in which VDDE also rises at GND). However, in the RAM backup mode (Power to VDDE only), the value of before deassertion of reset is held only in the RAM backup area.

## 6.3 Internal RAM Protect Function

This function monitors writes to the internal RAM.

Writes to the RAM can be disabled in 16-Kbyte units for area of H'0080 4000 to H'0084 3FFF. And if a write area set to disable is accessed for write, an interrupt can be generated.

Note: • The internal resources that are likely to access the internal RAM for write include six modules: CPU, DMA, SDI (tool), NBD, RTD, and DRI. Of these, the RTD and DRI are not subject to the RAM protect function, so that write accesses made to the internal RAM by the RTD or DRI cannot be detected.



The diagram below shows the areas in 16-Kbyte units of the internal RAM that can individually be disabled against write by the RAM protect function.

**Table 6.3.1 Definition of the Write Disabled Area**

Area	Target address	M32192F8	M32195F4	M32196F8
Area 0	H'0080 4000 - H'0080 7FFF	M32192F8 Internal RAM 176-Kbyte	M32195F4 Internal RAM 32-Kbyte	M32196F8 Internal RAM 64-Kbyte
Area 1	H'0080 8000 - H'0080 BFFF			
Area 2	H'0080 C000 - H'0080 FFFF			
Area 3	H'0081 0000 - H'0081 3FFF			
Area 4	H'0081 4000 - H'0081 7FFF			
Area 5	H'0081 8000 - H'0081 BFFF			
Area 6	H'0081 C000 - H'0081 FFFF			
Area 7	H'0082 0000 - H'0082 3FFF			
Area 8	H'0082 4000 - H'0082 7FFF			
Area 9	H'0082 8000 - H'0082 BFFF			
Area 10	H'0082 C000 - H'0082 FFFF			
Area 11	H'0083 0000 - H'0083 3FFF			
Area 12	H'0083 4000 - H'0083 7FFF	External area 80-Kbyte		
Area 13	H'0083 8000 - H'0083 BFFF			
Area 14	H'0083 C000 - H'0083 FFFF			
Area 15	H'0084 0000 - H'0084 3FFF			

A register map associated with the internal RAM protect function is shown below.

#### Internal RAM Protect Related Register Map

Address	+0 address	+1 address	See pages
	b0	b7 b8	b15
H'0080 0530	RAM Write Monitor Interrupt Status Register (RAMWRIST)		6-4
H'0080 0532	(Use inhibited area)		
H'0080 0534	RAM Write Source Status Register (RAMWRFST)		6-5
H'0080 0536	(Use inhibited area)		
H'0080 0538	RAM Write Disable Control Register (RAMWRCNT)		6-6
H'0080 053A	(Use inhibited area)		
H'0080 053C	(Use inhibited area)	RAM Write Disable Protect Register (RAMWRPROT)	6-7

RAM Write Monitor Interrupt Status Register (RAMWRIST)

&lt;Address: H'0080 0530&gt;

b0	1	2	3	4	5	6	7	8	9	10	11	12	13	14	b15
RAMWRIST0	RAMWRIST1	RAMWRIST2	RAMWRIST3	RAMWRIST4	RAMWRIST5	RAMWRIST6	RAMWRIST7	RAMWRIST8	RAMWRIST9	RAMWRIST10	RAMWRIST11	RAMWRIST12	RAMWRIST13	RAMWRIST14	RAMWRIST15
0	0	0	0	0	0	0	0	0	0	0	0	0	0	0	0

&lt;Upon exiting reset: H'0000&gt;

b	Bit Name	Function	R	W
0	RAMWRIST0 (Area 0 RAM write monitor interrupt status bit)	0: Area 0 interrupt not request 1: Area 0 interrupt requested	R	(Note 1)
1	RAMWRIST1 (Area 1 RAM write monitor interrupt status bit)	0: Area 1 interrupt not request 1: Area 1 interrupt requested	R	(Note 1)
2	RAMWRIST2 (Area 2 RAM write monitor interrupt status bit)	0: Area 2 interrupt not request 1: Area 2 interrupt requested	R	(Note 1)
3	RAMWRIST3 (Area 3 RAM write monitor interrupt status bit)	0: Area 3 interrupt not request 1: Area 3 interrupt requested	R	(Note 1)
4	RAMWRIST4 (Area 4 RAM write monitor interrupt status bit)	0: Area 4 interrupt not request 1: Area 4 interrupt requested	R	(Note 1)
5	RAMWRIST5 (Area 5 RAM write monitor interrupt status bit)	0: Area 5 interrupt not request 1: Area 5 interrupt requested	R	(Note 1)
6	RAMWRIST6 (Area 6 RAM write monitor interrupt status bit)	0: Area 6 interrupt not request 1: Area 6 interrupt requested	R	(Note 1)
7	RAMWRIST7 (Area 7 RAM write monitor interrupt status bit)	0: Area 7 interrupt not request 1: Area 7 interrupt requested	R	(Note 1)
8	RAMWRIST8 (Area 8 RAM write monitor interrupt status bit)	0: Area 8 interrupt not request 1: Area 8 interrupt requested	R	(Note 1)
9	RAMWRIST9 (Area 9 RAM write monitor interrupt status bit)	0: Area 9 interrupt not request 1: Area 9 interrupt requested	R	(Note 1)
10	RAMWRIST10 (Area 10 RAM write monitor interrupt status bit)	0: Area 10 interrupt not request 1: Area 10 interrupt requested	R	(Note 1)
11	RAMWRIST11 (Area 11 RAM write monitor interrupt status bit)	0: Area 11 interrupt not request 1: Area 11 interrupt requested	R	(Note 1)
12	RAMWRIST12 (Area 12 RAM write monitor interrupt status bit)	0: Area 12 interrupt not request 1: Area 12 interrupt requested	R	(Note 1)
13	RAMWRIST13 (Area 13 RAM write monitor interrupt status bit)	0: Area 13 interrupt not request 1: Area 13 interrupt requested	R	(Note 1)
14	RAMWRIST14 (Area 14 RAM write monitor interrupt status bit)	0: Area 14 interrupt not request 1: Area 14 interrupt requested	R	(Note 1)
15	RAMWRIST15 (Area 15 RAM write monitor interrupt status bit)	0: Area 15 interrupt not request 1: Area 15 interrupt requested	R	(Note 1)

Note 1: Only writing "0" is effective. Writing "1" has no effect; the bit retains the value it had before the write.

Note: • This register must always be accessed in halfwords.

If the CPU, DMA, SDI (tool), or NBD attempted to write to any area that is "disabled against write" by the RAM Write Disable Control Register, the corresponding bit in this register is set to "1." The bit is cleared by writing a "0" in software.

When writing to this register, be sure to write a "0" for the bits to be cleared and a "1" for all other bits. Writing a "1" to any bit in this register has no effect, so the bit retains the value it had before the write.

RAM Write Source Status Register (RAMWRFST)

&lt;Address: H'0080 0534&gt;

b0	1	2	3	4	5	6	7	8	9	10	11	12	13	14	b15
RAMWRFST0	RAMWRFST1	RAMWRFST2	RAMWRFST3	RAMWRFST4	RAMWRFST5	RAMWRFST6	RAMWRFST7	RAMWRFST8	RAMWRFST9	RAMWRFST10	RAMWRFST11	RAMWRFST12	RAMWRFST13	RAMWRFST14	RAMWRFST15
0	0	0	0	0	0	0	0	0	0	0	0	0	0	0	0

&lt;Upon exiting reset: H'0000&gt;

b	Bit Name	Function	R	W
0	RAMWRFST0 (Area 0 RAM write source status bit)	0: Write to area 0 by DMA 1: Write to area 0 by CPU, SDI, or NBD	R (Note 1)	
1	RAMWRFST1 (Area 1 RAM write source status bit)	0: Write to area 1 by DMA 1: Write to area 1 by CPU, SDI, or NBD	R (Note 1)	
2	RAMWRFST2 (Area 2 RAM write source status bit)	0: Write to area 2 by DMA 1: Write to area 2 by CPU, SDI, or NBD	R (Note 1)	
3	RAMWRFST3 (Area 3 RAM write source status bit)	0: Write to area 3 by DMA 1: Write to area 3 by CPU, SDI, or NBD	R (Note 1)	
4	RAMWRFST4 (Area 4 RAM write source status bit)	0: Write to area 4 by DMA 1: Write to area 4 by CPU, SDI, or NBD	R (Note 1)	
5	RAMWRFST5 (Area 5 RAM write source status bit)	0: Write to area 5 by DMA 1: Write to area 5 by CPU, SDI, or NBD	R (Note 1)	
6	RAMWRFST6 (Area 6 RAM write source status bit)	0: Write to area 6 by DMA 1: Write to area 6 by CPU, SDI, or NBD	R (Note 1)	
7	RAMWRFST7 (Area 7 RAM write source status bit)	0: Write to area 7 by DMA 1: Write to area 7 by CPU, SDI, or NBD	R (Note 1)	
8	RAMWRFST8 (Area 8 RAM write source status bit)	0: Write to area 8 by DMA 1: Write to area 8 by CPU, SDI, or NBD	R (Note 1)	
9	RAMWRFST9 (Area 9 RAM write source status bit)	0: Write to area 9 by DMA 1: Write to area 9 by CPU, SDI, or NBD	R (Note 1)	
10	RAMWRFST10 (Area 10 RAM write source status bit)	0: Write to area 10 by DMA 1: Write to area 10 by CPU, SDI, or NBD	R (Note 1)	
11	RAMWRFST11 (Area 11 RAM write source status bit)	0: Write to area 11 by DMA 1: Write to area 11 by CPU, SDI, or NBD	R (Note 1)	
12	RAMWRFST12 (Area 12 RAM write source status bit)	0: Write to area 12 by DMA 1: Write to area 12 by CPU, SDI, or NBD	R (Note 1)	
13	RAMWRFST13 (Area 13 RAM write source status bit)	0: Write to area 13 by DMA 1: Write to area 13 by CPU, SDI, or NBD	R (Note 1)	
14	RAMWRFST14 (Area 14 RAM write source status bit)	0: Write to area 14 by DMA 1: Write to area 14 by CPU, SDI, or NBD	R (Note 1)	
15	RAMWRFST15 (Area 15 RAM write source status bit)	0: Write to area 15 by DMA 1: Write to area 15 by CPU, SDI, or NBD	R (Note 1)	

Note 1: Only writing "0" is effective. Writing "1" has no effect; the bit retains the value it had before the write.

If the CPU, SDI(tool), or NBD attempted to access any area for write that is "disabled against write" by the RAM Write Disable Control Register, the corresponding bit in this register is set to "1." After setting the bit to "1," the bit is not cleared to "0" if a DMA write access occurred. The bit is cleared by writing a "0" in software. Writing a "1" to any bit in this register has no effect, so the bit retains the value it had before the write.

RAM Write Disable Control Register (RAMWRCNT)

&lt;Address: H'0080 0538&gt;

b0	1	2	3	4	5	6	7	8	9	10	11	12	13	14	b15
RAMWRCNT0	RAMWRCNT1	RAMWRCNT2	RAMWRCNT3	RAMWRCNT4	RAMWRCNT5	RAMWRCNT6	RAMWRCNT7	RAMWRCNT8	RAMWRCNT9	RAMWRCNT10	RAMWRCNT11	RAMWRCNT12	RAMWRCNT13	RAMWRCNT14	RAMWRCNT15
0	0	0	0	0	0	0	0	0	0	0	0	0	0	0	0

&lt;Upon exiting reset: H'0000&gt;

b	Bit Name	Function	R	W
0	RAMWRCNT0 (Area 0 RAM write disable control bit)	0: Enable write to area 0 1: Disable write to area 0	R	W
1	RAMWRCNT1 (Area 1 RAM write disable control bit)	0: Enable write to area 1 1: Disable write to area 1	R	W
2	RAMWRCNT2 (Area 2 RAM write disable control bit)	0: Enable write to area 2 1: Disable write to area 2	R	W
3	RAMWRCNT3 (Area 3 RAM write disable control bit)	0: Enable write to area 3 1: Disable write to area 3	R	W
4	RAMWRCNT4 (Area 4 RAM write disable control bit)	0: Enable write to area 4 1: Disable write to area 4	R	W
5	RAMWRCNT5 (Area 5 RAM write disable control bit)	0: Enable write to area 5 1: Disable write to area 5	R	W
6	RAMWRCNT6 (Area 6 RAM write disable control bit)	0: Enable write to area 6 1: Disable write to area 6	R	W
7	RAMWRCNT7 (Area 7 RAM write disable control bit)	0: Enable write to area 7 1: Disable write to area 7	R	W
8	RAMWRCNT8 (Area 8 RAM write disable control bit)	0: Enable write to area 8 1: Disable write to area 8	R	W
9	RAMWRCNT9 (Area 9 RAM write disable control bit)	0: Enable write to area 9 1: Disable write to area 9	R	W
10	RAMWRCNT10 (Area 10 RAM write disable control bit)	0: Enable write to area 10 1: Disable write to area 10	R	W
11	RAMWRCNT11 (Area 11 RAM write disable control bit)	0: Enable write to area 11 1: Disable write to area 11	R	W
12	RAMWRCNT12 (Area 12 RAM write disable control bit)	0: Enable write to area 12 1: Disable write to area 12	R	W
13	RAMWRCNT13 (Area 13 RAM write disable control bit)	0: Enable write to area 13 1: Disable write to area 13	R	W
14	RAMWRCNT14 (Area 14 RAM write disable control bit)	0: Enable write to area 14 1: Disable write to area 14	R	W
15	RAMWRCNT15 (Area 15 RAM write disable control bit)	0: Enable write to area 15 1: Disable write to area 15	R	W

This register controls accesses for write to the RAM by enabling or disabling the access. Controlled by this register are the accesses made by the CPU, DMA, SDI (tool), and NBD. If one of these modules attempted to access any area for write that is disabled against write, the corresponding RAM write monitor interrupt status is set to "1," with no data actually written to the RAM.

Before this register can be rewritten, the RAMWRCNTPRO bit in the RAM Write Disable Protect Register must be "0."

RAM Write Disable Protect Register (RAMWRPROT)

&lt;Address: H'0080 053D&gt;

b8	9	10	11	12	13	14	b15
0	0	0	0	0	0	RAMWRCNTP 0	RAMWRCNTPRO 0

&lt;Upon exiting reset: H'00&gt;

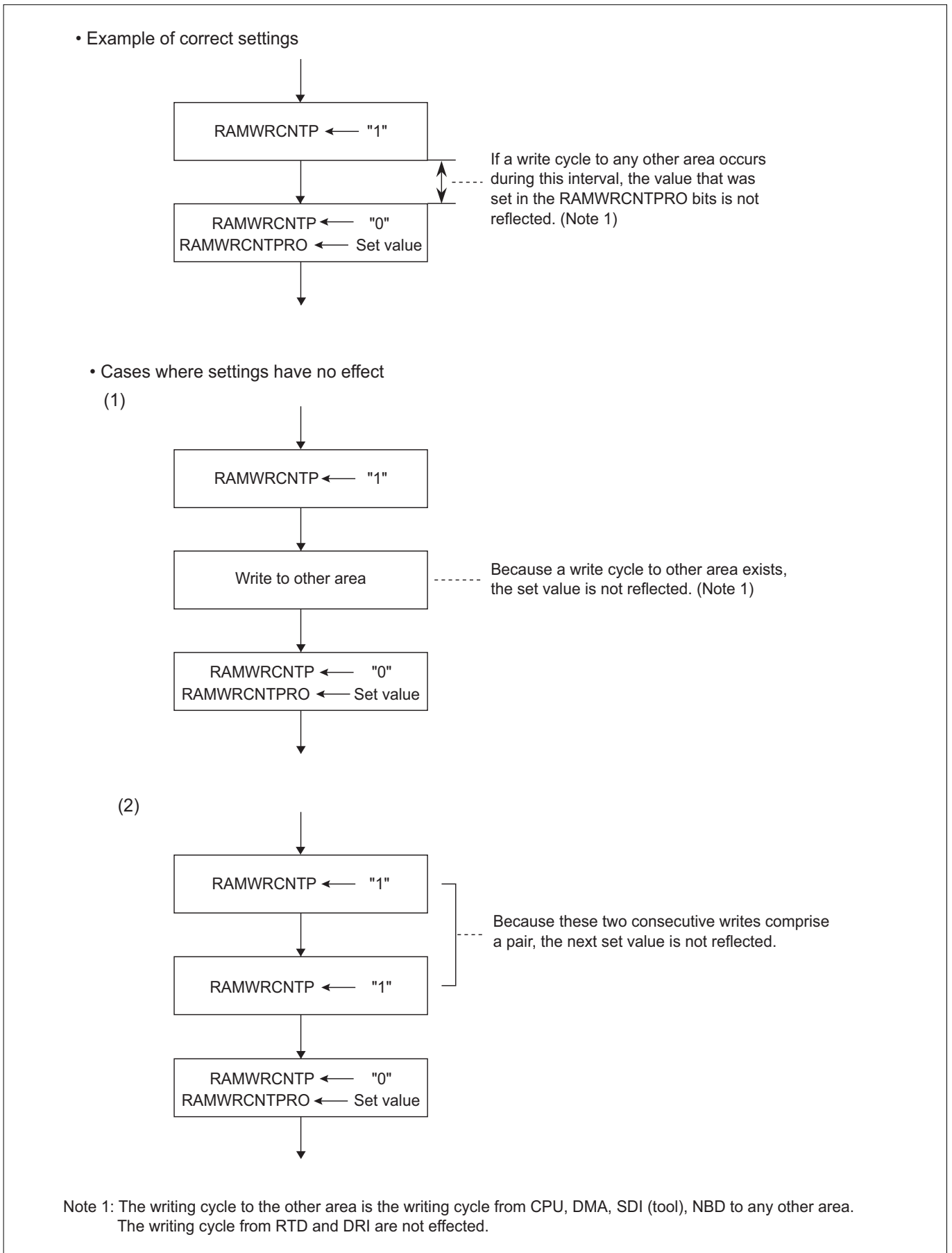
b	Bit Name	Function	R	W
8–13	No function assigned. Fix to "0."		0	0
14	RAMWRCNTP RAMWRCNTPRO write control bit		0	W
15	RAMWRCNTPRO RAM write disable protect bit	0: Enable write to RAMWRCNTn 1: Disable write to RAMWRCNTn	R	W

This register controls writes to the RAM Write Disable Control Register by enabling or disabling the write. If a write to the RAM Write Disable Control Register is attempted when the RAMWRCNTPRO bit = "1," the attempted write is ignored.

To set this register, follow the procedure described below.

1. Write a "1" to RAMWRCNTP.
2. Subsequent to 1 above, write a "0" to RAMWRCNTP and a set value ("0" or "1") to RAMWRCNTPRO.

Note: • If there are writing cycles from CPU, DMA, SDI (tool), NBD to any other area between 1 and 2, the continuous setting ( A pair of two consecutive is 1 set for writing operation) is disabled and the writing value is not reflected. Therefore, disable interrupts and DMA transfers before setting. However the writing cycle from RTD and DRI are not effected.



**Figure 6.3.1 RAMWRCNTPRO Setting Procedure**

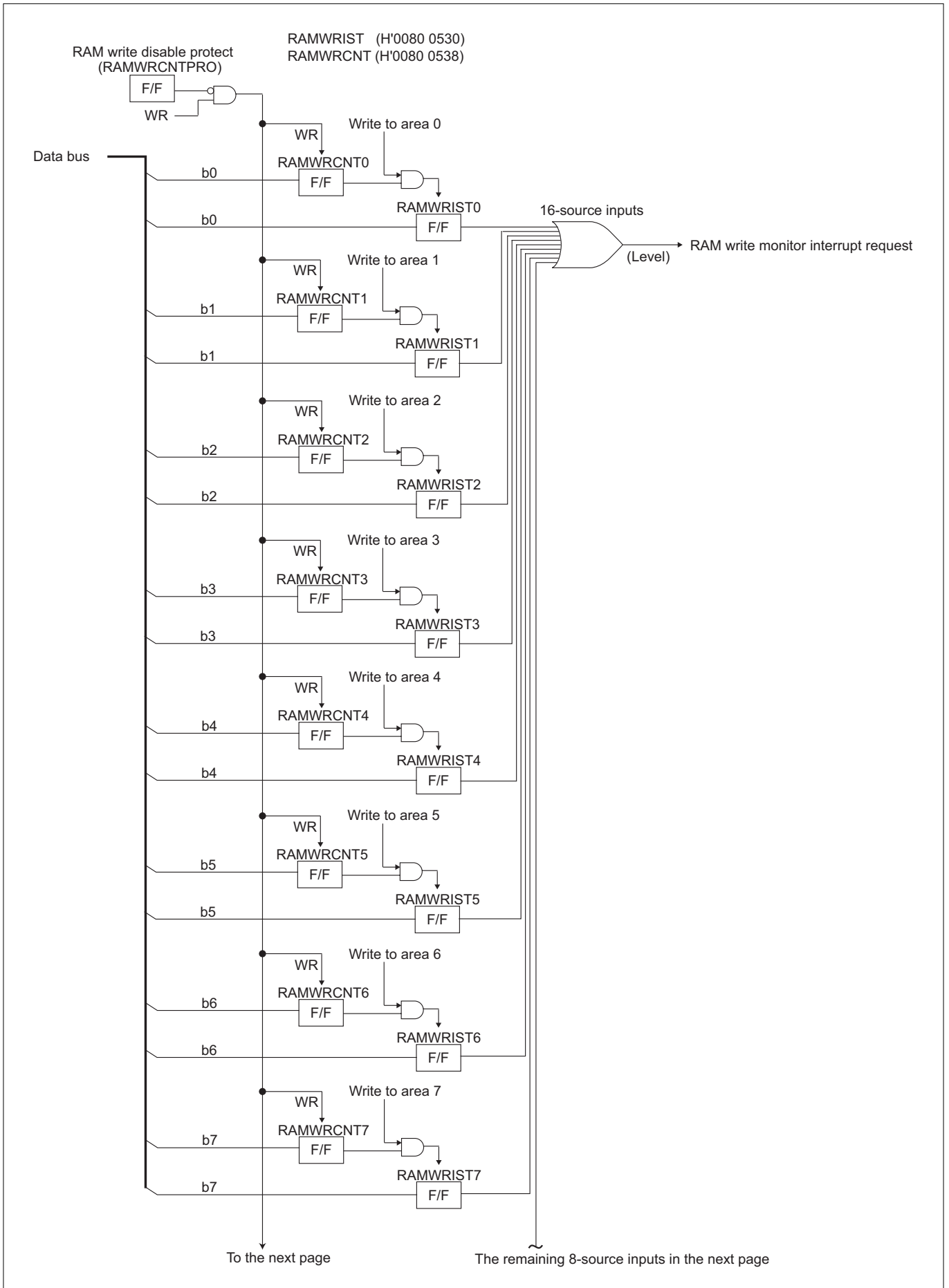


Figure 6.3.2 Block Diagram of RAM Write Monitor Interrupt Request (1/2)

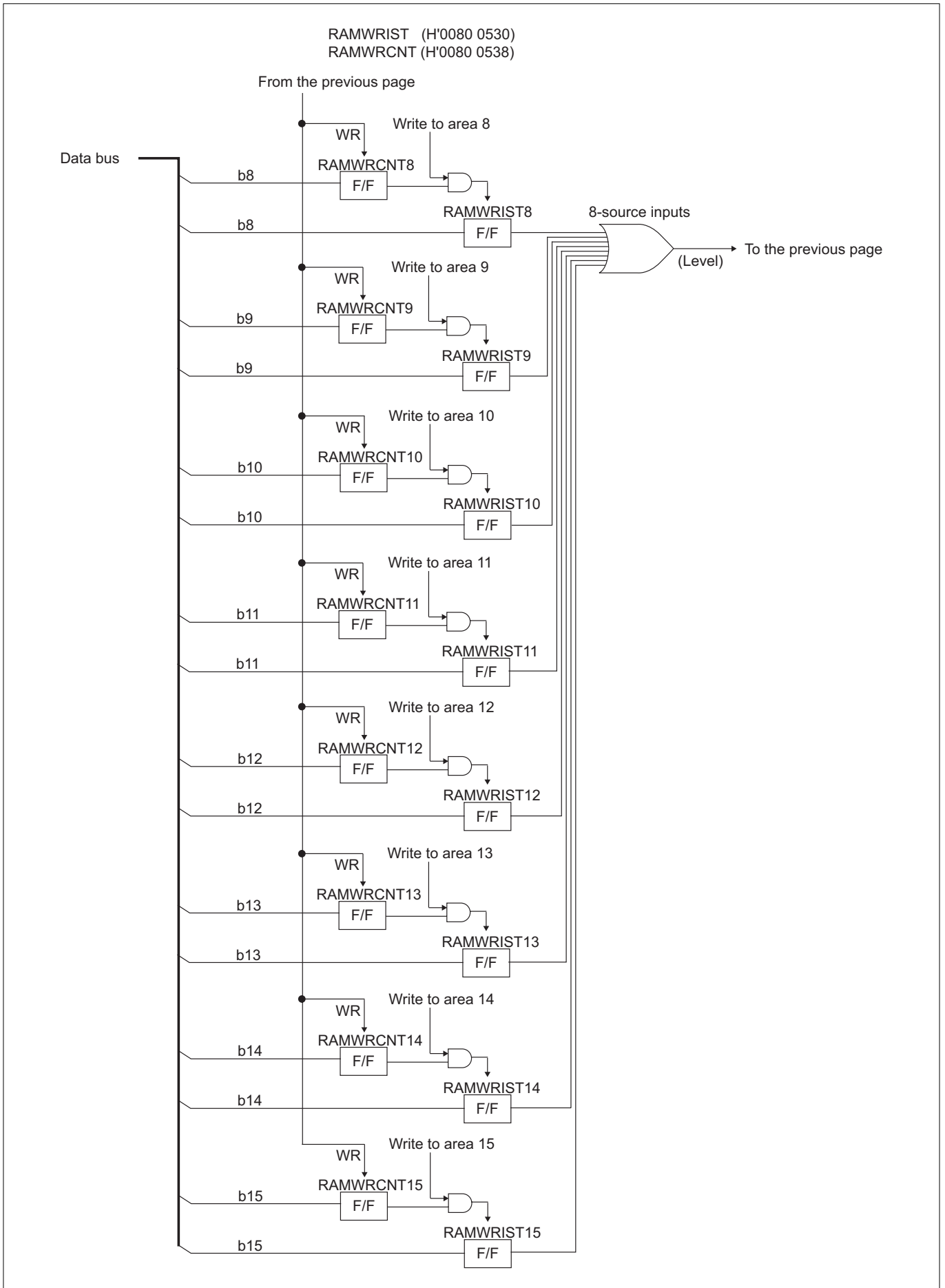


Figure 6.3.3 Block Diagram of RAM Write Monitor Interrupt Request (2/2)

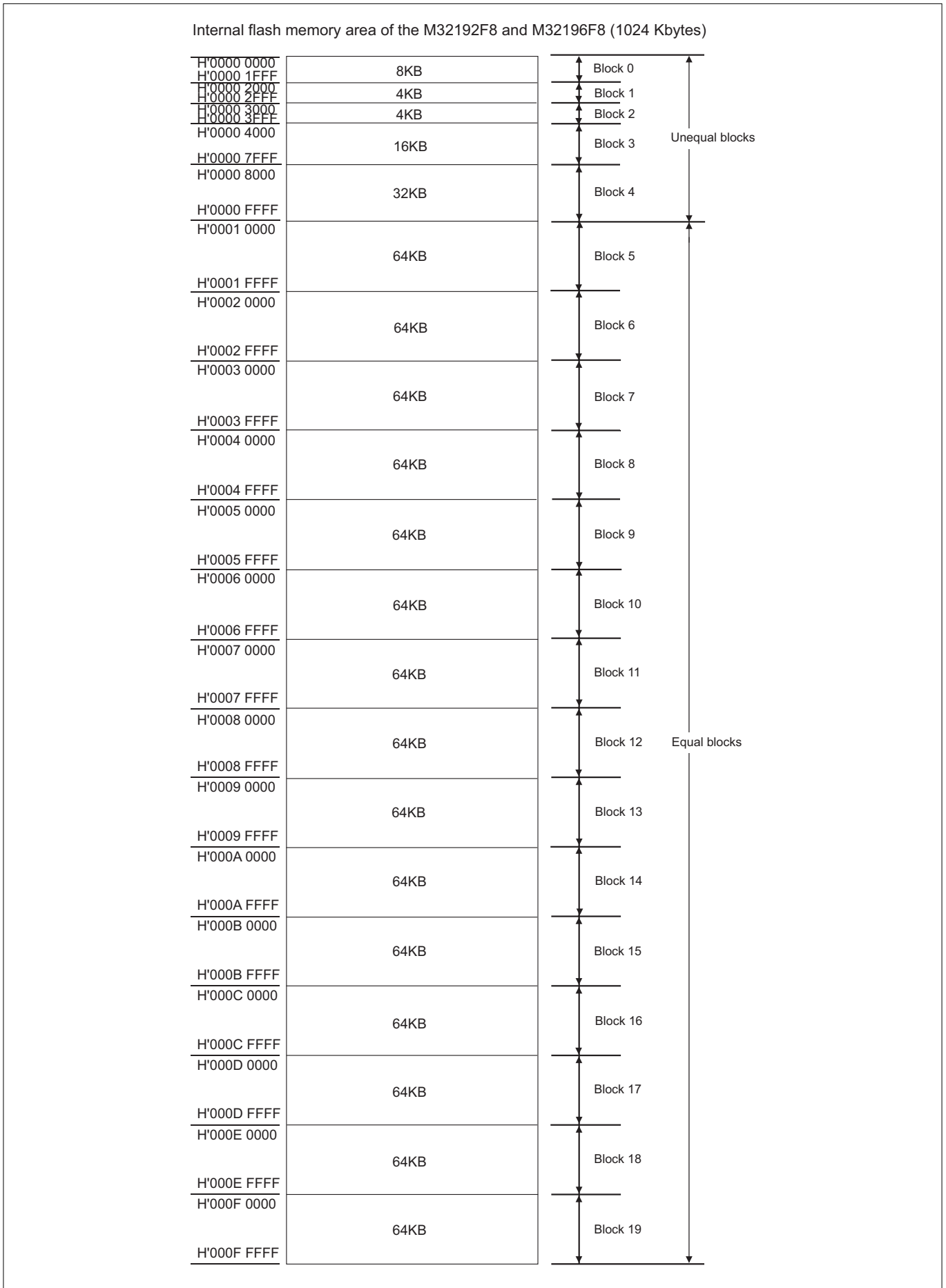


## 6.4 Internal Flash Memory

Specifications of the internal flash memory are shown below.

**Table 6.4.1 Specifications of the Internal Flash Memory**

Item	Specification
Size	M32192F8 : 1 Mbyte (1024 Kbytes) M32195F4 : 512 Kbytes M32196F8 : 1 Mbyte (1024 Kbytes)
Location address	M32192F8 : H'0000 0000 to H'000F FFFF M32195F4 : H'0000 0000 to H'0007 FFFF M32196F8 : H'0000 0000 to H'000F FFFF
Wait insertion	Operates with one wait state
Durability	Standard product : 100 times
Internal bus connection achieved)	Instruction access: Connected by 64-bit bus (32-bit: Transfer rate equivalent to zero-wait states Data access: Connected by 32-bit bus
Other	Virtual flash emulation function is incorporated. (See Section 6.7, "Virtual Flash Emulation function.")



**Figure 6.4.1 Block Configuration of the Internal Flash Memory for the M32192F8 and M32196F8**

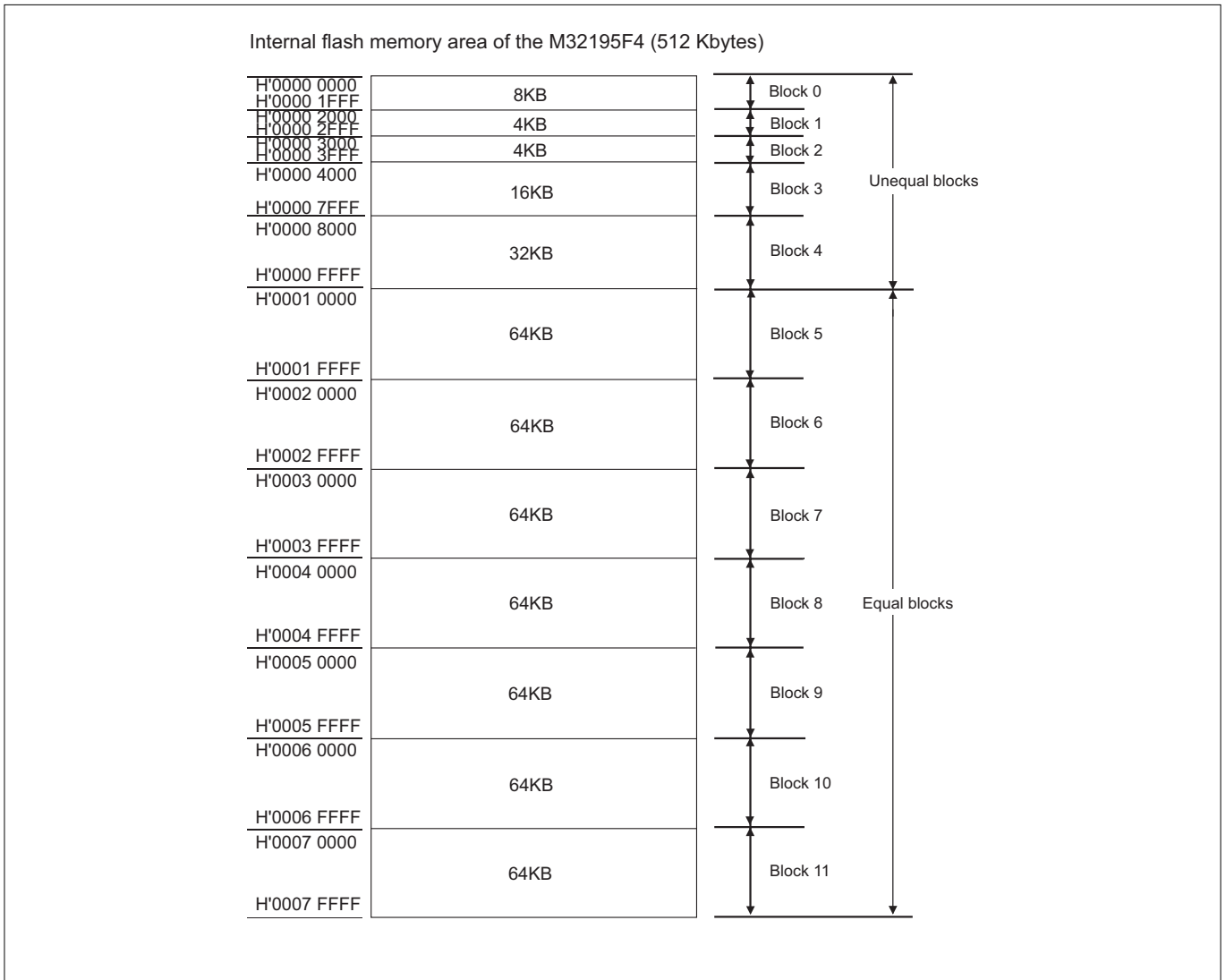


Figure 6.4.2 Block Configuration of the Internal Flash Memory for the M32195F4

## 6.5 Registers Associated with the Internal Flash Memory

A register map associated with the internal flash memory is shown below.

### Internal Flash Memory Related Register Map

Address	+0 address		+1 address		See pages
	b0	b7	b8	b15	
H'0080 01E0	Flash Mode Register (FMODE)		Flash Status Register (FSTAT)		6-15 6-16
H'0080 01E2	Flash Control Register 1 (FCNT1)		Flash Control Register 2 (FCNT2)		6-17 6-18
H'0080 01E4	Flash Control Register 3 (FCNT3)		Flash Control Register 4 (FCNT4)		6-19 6-22
H'0080 07E8	Virtual Flash L Bank Register 0 (FELBANK0)				6-24
H'0080 07EA	Virtual Flash L Bank Register 1 (FELBANK1)				6-24
H'0080 07EC	Virtual Flash L Bank Register 2 (FELBANK2)				6-24
H'0080 07EE	Virtual Flash L Bank Register 3 (FELBANK3)				6-24
H'0080 07F0	Virtual Flash L Bank Register 4 (Note 2) (FELBANK4)				6-24
H'0080 07F2	Virtual Flash L Bank Register 5 (Note 2) (FELBANK5)				6-24
H'0080 07F4	Virtual Flash L Bank Register 6 (Note 2) (FELBANK6)				6-24
H'0080 07F6	Virtual Flash L Bank Register 7 (Note 2) (FELBANK7)				6-24
H'0080 07F8	Virtual Flash L Bank Register 8 (Note 1) (FELBANK8)				6-24
H'0080 07FA	Virtual Flash L Bank Register 9 (Note 1) (FELBANK9)				6-24
H'0080 07FC	Virtual Flash L Bank Register 10 (Note 1) (FELBANK10)				6-24
H'0080 07FE	Virtual Flash L Bank Register 11 (Note 1) (FELBANK11)				6-24
H'0080 0800	Virtual Flash L Bank Register 12 (Note 1) (FELBANK12)				6-24
H'0080 0802	Virtual Flash L Bank Register 13 (Note 1) (FELBANK13)				6-24
H'0080 0804	Virtual Flash L Bank Register 14 (Note 1) (FELBANK14)				6-24
H'0080 0806	Virtual Flash L Bank Register 15 (Note 1) (FELBANK15)				6-24

Note 1: This area exists only in the 32192 and it is use prohibition area in the 32195/32196.

Note 2: This area exists only in the 32192/32196 and it is use prohibition area in the 32195.

## 6.5.1 Flash Mode Register

Flash Mode Register (FMODE)

&lt;Address: H'0080 01E0&gt;

b0	1	2	3	4	5	6	b7
0	0	0	FAENS 1	0	0	0	FPMOD ?

&lt;Upon exiting reset: H'1?&gt;

b	Bit Name	Function	R	W
0–2	No function assigned. Fix to "0"		0	0
3	FAENS Flash access enable status bit	0: Flash access disabled 1: Flash access enabled	R	–
4–6	No function assigned. Fix to "0"		0	0
7	FPMOD External FP pin status bit	0: FP pin = "L" 1: FP pin = "H"	R	–

**(1) FAENS (Flash Access Enable Status) bit (Bit 3)**

The FAENS bit shows whether access to the flash memory is enabled or disabled. When the flash memory is reset by the FRESET bit in Flash Control Register 4 (FCNT4) or accessed for programming/erasure, this bit is cleared to "0," resulting in the flash memory being disabled against access. When the flash memory becomes ready for access, this bit is set to "1." However, it requires up to 30  $\mu$ s for FAENS bit to be "1" from "0" after exiting Flash reset by FRESET bit or executing programming and erasing operation for Flash memory.

**(2) FPMOD (External FP Pin Status) bit (Bit 7)**

The FPMOD is a status bit which indicates the FP (Flash Protect) pin status.

The internal flash memory is enabled for programming or erase operation only when FPMOD = "1," and is protected against programming or erase operation when FPMOD = "0."

## 6.5.2 Flash Status Register

Flash Status Register (FSTAT)

&lt;Address: H'0080 01E1&gt;

b8	9	10	11	12	13	14	b15
FBUSY		ERASE	WRERR		FESQ1	FESQ2	
1	0	0	0	0	0	0	0

&lt;Upon exiting reset: H'80&gt;

b	Bit Name	Function	R	W
8	FBUSY Flash busy bit	0: Being programmed or erased 1: Ready state	R	-
9	No function assigned. Fix to "0."		0	0
10	ERASE Erase status confirmation bit	0: Erase normally operating or terminated 1: Erase error occurred	R	-
11	WRERR Write status confirmation bit	0: Programming normally operating or terminated 1: Programming error occurred	R	-
12	No function assigned. Fix to "0."		0	0
13	FESQ1 Reserved bit		?	-
14	FESQ2 Reserved bit		?	-
15	No function assigned. Fix to "0."		0	0

Flash Status Register (FSTAT) consists of the following status bits that indicate the operation condition of the flash memory.

**(1) FBUSY (Flash Busy) bit (Bit 8)**

The FBUSY bit is used to determine whether the operation on the flash memory is finished when it is being programmed or erased. When FBUSY = "0," it means that the programming or erase operation is being executed; when FBUSY = "1," the operation is finished.

Note: • Except when programming/erase processing on the flash memory is forcibly terminated, do not manipulate the FRESET bit in Flash Control Register 4 (FCNT4) while the FBUSY bit = "0" (programming/erasure in progress).

**(2) ERASE (Erase Status Confirmation) bit (Bit 10)**

The ERASE bit is used to determine after execution of processing whether the erase operation performed on the flash memory resulted in an error. When ERASE = "0," it means that the erase operation terminated normally; when ERASE = "1," the erase operation terminated in an error.

This bit is set to "1" (Erase error occurred) in the following cases:

- An invalid command is issued
- The operation is not executed under normal erase conditions (power voltage, temperature)
- Protect function by lock bit attempts to erase the valid area
- Erase operation is not available because of the internal flash memory failure

**(3) WRERR (Write Status Confirmation) bit (Bit 11)**

The WRERR bit is used to determine after completion of processing whether the programming operation performed on the flash memory resulted in an error. When WRERR = "0," it means that the programming operation terminated normally; when WRERR = "1," the programming operation terminated in an error.

This bit is set to "1" (Programming error occurred) in the following cases:

- An invalid command is issued
- The operation is not executed under normal programming conditions (power voltage, temperature)
- Protect function by lock bit attempts to write to the valid area
- Write operation is not available because of the internal flash memory failure

## 6.5.3 Flash Control Registers

Flash Control Register 1 (FCNT1)

&lt;Address: H'0080 01E2&gt;

b0	1	2	3	4	5	6	b7
0	0	0	FENTRY 0	0	0	0	FEMMOD 0

&lt;Upon exiting reset: H'00&gt;

b	Bit Name	Function	R	W
0–2	No function assigned. Fix to "0."		0	0
3	FENTRY Flash E/W enable mode entry bit	0: Normal read 1: Program/erase enable	R	W
4–6	No function assigned. Fix to "0."		0	0
7	FEMMOD Virtual flash emulation mode bit	0: Normal mode 1: Virtual flash emulation mode	R	W

Flash Control Register 1 (FCNT1) consists of the following two bits to control the internal flash memory.

**(1) FENTRY (Flash E/W Enable Mode Entry) bit (Bit 3)**

The FENTRY bit controls entry to flash E/W enable mode. Flash E/W enable mode can only be entered when FENTRY = "1."

To set the FENTRY bit to "1," write "0" and then "1" to the FENTRY bit in succession while the FP pin = "H." To clear the FENTRY bit, check to see that the Flash Status Register (FSTAT) FBUSY bit = "1" (ready), issue Read Array commands (or Flash memory reset by FRESET bit), make sure that FAENS bit = "1," and then write "0" to the FENTRY bit. However, when Flash memory is not reset by FRESET bit, it is not required to check the FAENS bit.

Note that the following operations cannot be performed while programming or erasing the internal flash memory (FSTAT register FBUSY bit = "0"). If one of these operations is attempted, the FENTRY bit is cleared to "0" in hardware.

- 1) Writing "0" to the FENTRY bit
- 2) Entering a "L" level signal to the FP pin
- 3) Entering a "L" level signal to the RESET# pin

When running a program resident in the internal flash memory while the FENTRY bit = "0," the EI vector entry is located at the address H'0000 0080 of the internal flash memory. When running the flash write/erase program in the RAM while the FENTRY bit = "1," the EI vector entry is located at the address H'0080 4000 of the RAM, allowing the flash programming/erase operation to be controlled using interrupts.

**Table 6.5.1 Changes of the EI Vector Entry by FENTRY**

FENTRY	EI Vector Entry	Address
0	Internal flash memory area	H'0000 0080
1	Internal RAM area	H'0080 4000

**(2) FEMMOD (Virtual Flash Emulation Mode) bit (Bit 7)**

The FEMMOD bit controls entry to virtual flash emulation mode. Virtual flash emulation mode is entered by setting the FEMMOD bit to "1" while the FENTRY bit = "0." (For details, see Section 6.7, "Virtual Flash Emulation Function.")

Flash Control Register 2 (FCNT2)

&lt;Address: H'0080 01E3&gt;

b8	9	10	11	12	13	14	b15
0			FLOCKS	0			FPROT
0			0	0			0

&lt;Upon exiting reset: H'00&gt;

b	Bit Name	Function	R	W
8–10	No function assigned. Fix to "0."		0	0
11	FLOCKS Lock bit read mode select bit	0: Memory area read mode 1: Register read mode	R(Note 1)	
12–14	No function assigned. Fix to "0."		0	0
15	FPROT Lock bit protect control bit	0: Protection by lock bit effective 1: Protection by lock bit invalidated	R(Note 1)	

Note 1: It can be accessed for write only during the Flash E/W entry mode (FENTRY bit = "1").

**(1) FLOCKS (Lock Bit Read Mode Select) bit (Bit 11)**

The FLOCKS bit is used to select a method for reading out the lock bit status. When the FLOCKS bit = "0," the internal flash memory is placed in memory area read mode, so that it is possible to inspect the lock bit status by issuing command data H'7171 to any address of the flash memory and then reading the last even address of the target block. When the FLOCKS bit = "1," the internal flash memory is placed in register read mode, so that it is possible to inspect the lock bit status by first issuing command data H'7171 and H'D0D0 to any address of the target block in succession and then, when the FBUSY bit is set to "1," by reading the FLOCKST bit in Flash Control Register 4.

The FLOCKS bit can only be accessed for write when the FENTRY bit = "1."

If one of the following operations is attempted, the FLOCKS bit is cleared to "0."

- 1) Writing "0" to the FLOCKS bit
- 2) Entering a "L" level signal to the FP pin
- 3) Clearing the FENTRY bit to "0"
- 4) Entering a "L" level signal to the RESET# pin

**(2) FPROT (Lock Bit Protect Control) bit (Bit 15)**

The FPROT bit controls invalidation of the internal flash memory protection by a lock bit (protection against programming/erase operation). Protection of the internal flash memory is invalidated by setting the FPROT bit to "1," so that any blocks protected by a lock bit can now be programmed or erased.

To set the FPROT bit to "1," write "0" and then "1" to the FPROT bit in succession while the FENTRY bit = "1." To clear the FPROT bit to "0," write "0" to the FPROT bit.

If one of the following operations is attempted, the FPROT bit is cleared to "0."

- 1) Writing "0" to the FPROT bit
- 2) Entering a "L" level signal to the FP pin
- 3) Clearing the FENTRY bit to "0"
- 4) Entering a "L" level signal to the RESET# pin



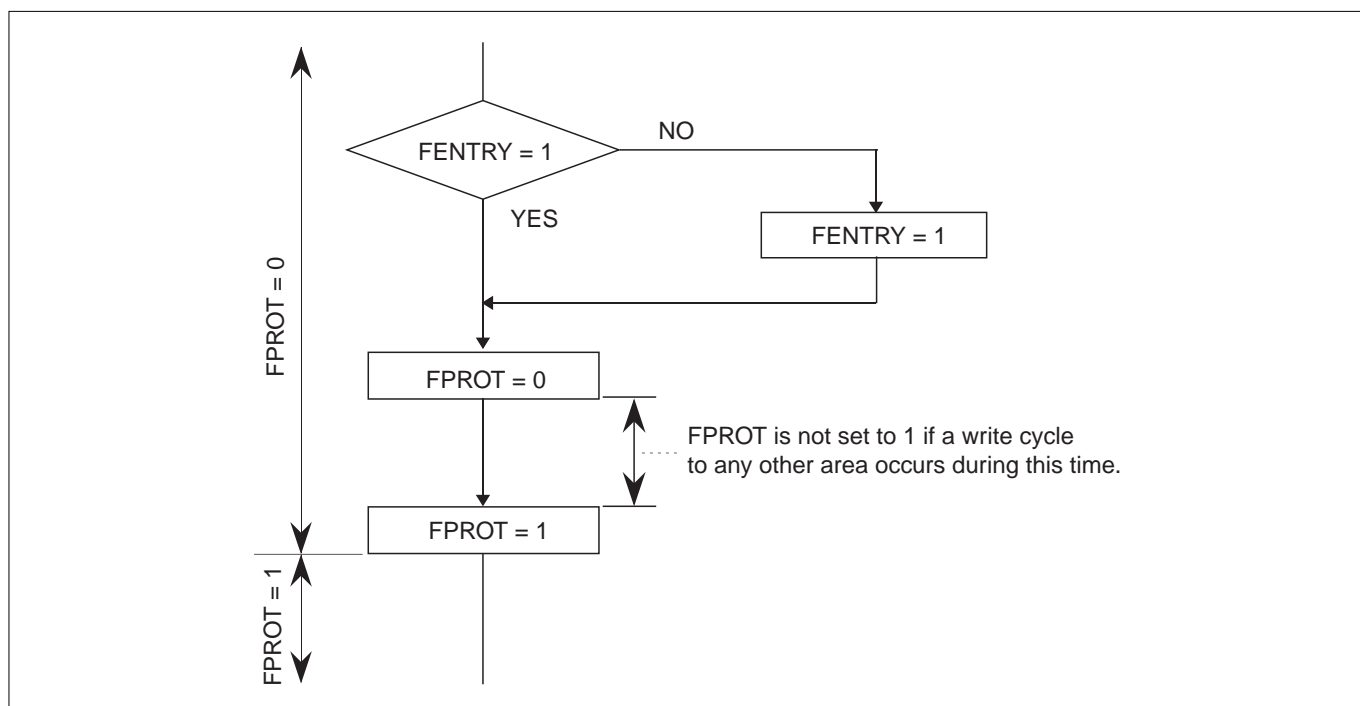


Figure 6.5.1 Protection Unlocking Flow

Flash Control Register 3 (FCNT3)

&lt;Address: H'0080 01E4&gt;

b0	1	2	3	4	5	6	b7
0	0	0	FBSYCK 1	0	0	0	FPBSYCK 1

&lt;Upon exiting reset: H'11&gt;

b	Bit Name	Function	R	W
0–2	No function assigned. Fix to "0."		0	0
3	FBSYCK Busy check bit	0: Command accepted normally 1: Command not accepted normally	R	–
4–6	No function assigned. Fix to "0."		0	0
7	FPBSYCK Prebusy check bit	0: Command accepted normally 1: Command not accepted normally	R	–

Flash Control Register 3 (FCNT3) is used when developing an internal flash memory write/erase program to check whether commands have been accepted normally. This register does not need to be used for a program that has been verified to be able to operate properly.

### (1) FBSYCK (Busy Check) bit (Bit 3)

The FBSYCK bit is used to check whether the command of two or more cycles (confirmation command H'D0D0 or a command that requires write data) issued to the flash memory during flash E/W enable mode has been accepted normally. Commands of two or more cycles are shown in Table 6.5.2. If the FBSYCK bit is found to be "0" after issuing the busy check target command (See Table 6.5.2), it means that the busy check target command has been accepted normally. Conversely, if the FBSYCK bit is found to be "1," it means that the busy check target command has not been accepted normally.

In addition to the above, the FBSYCK bit is set to "1" in the following cases:

- 1) When a prebusy check target command has been accepted
- 2) When the FRESET bit = "1"
- 3) When input on RESET# pin is pulled "L"

**(2) FPBSYCK (Prebusy Check) bit (Bit 7)**

The FPBSYCK bit is used to check whether the command of two or more cycles (confirmation command H'D0D0 or a command that requires write data) issued to the flash memory during flash E/W enable mode has been accepted normally. If the FPBSYCK bit is found to be "0" after issuing the prebusy check target command (See Table 6.5.2), it means that the prebusy check target command has been accepted normally. Conversely, if the FPBSYCK bit is found to be "1," it means that the prebusy check target command has not been accepted normally.

In addition to the above, the FPBSYCK bit is set to "1" in the following cases:

- 1) When in a ready state (FBUSY bit = "H" after a prebusy check target command has been accepted)
- 2) When the Clear Status Register command is issued
- 3) When the FRESET bit = "1"
- 4) When input on RESET# pin is pulled "L"

**Table 6.5.2 Prebusy, Busy Check Target Comand**

Lock bit Program		Block Erase		Read Lock bit Status (during Register read mode)		4 Halfword Program	
Write H'7777 (Lock bit program command)	(Note1)	Write H'2020 (Block erase command)	(Note1)	Write H'7171 (Read lock bit status command)	(Note1)	Write H'4343 (4 halfword program command)	—
Write H'D0D0 (Confirmation command)	(Note2)	Write H'D0D0 (Confirmation command)	(Note2)	Write H'D0D0 (Confirmation command)	(Note2)	Write halfword data	—
—	—	—	—	—	—	Write halfword data	—
—	—	—	—	—	—	Write halfword data	(Note1)
—	—	—	—	—	—	Write halfword data	(Note2)

Note 1: Prebusy check target command

Note 2: Busy check target command

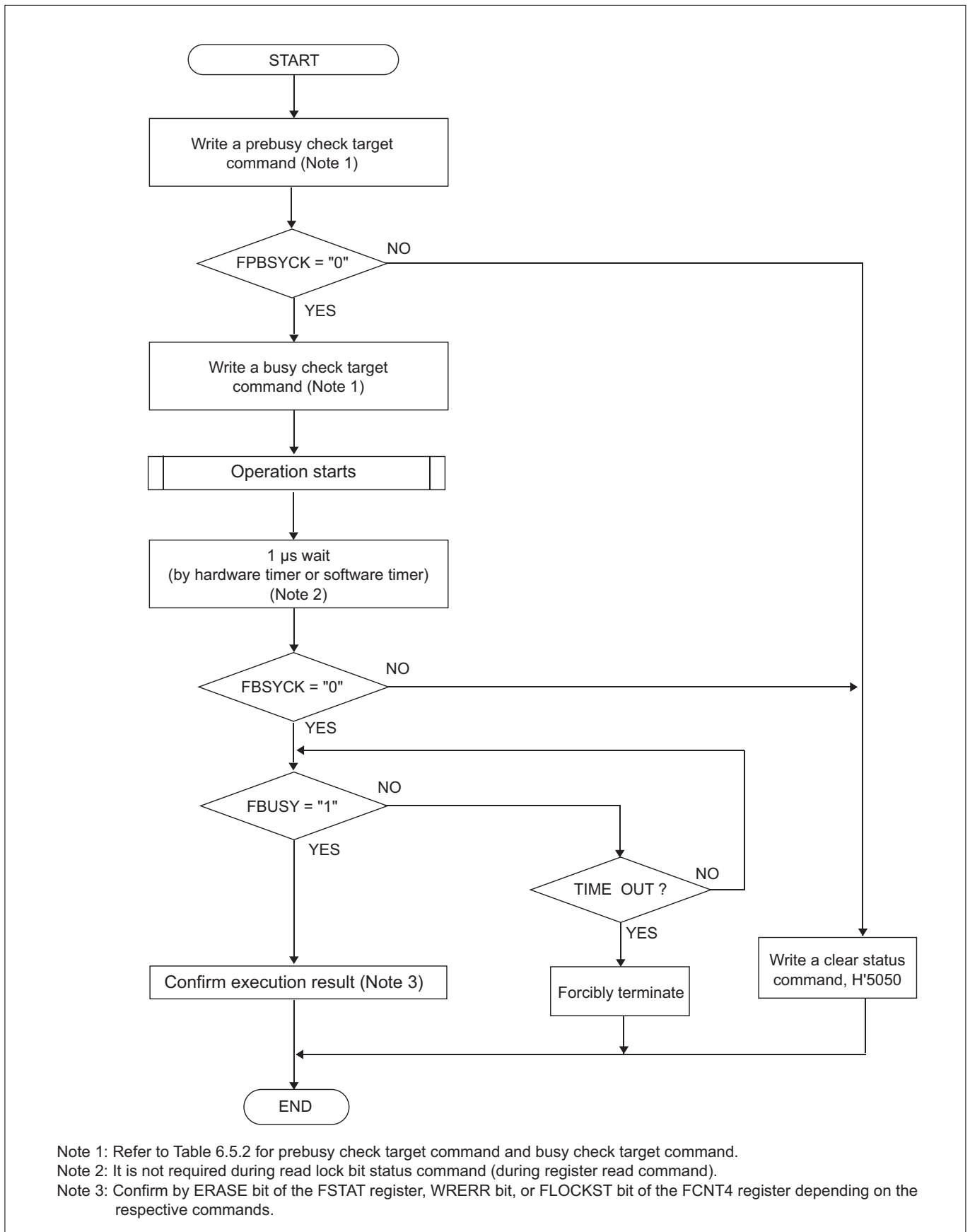


Figure 6.5.2 Method to Confirm the Command Acceptance by Checking FCNT3

Flash Control Register 4 (FCNT4)

&lt;Address: H'0080 01E5&gt;

b8	9	10	11	12	13	14	b15
0	0	0	FLOCKST 0	0	0	0	FRESET 0

&lt;Upon exiting reset: H'00&gt;

b	Bit Name	Function	R	W
8–10	No function assigned. Fix to "0."		0	0
11	FLOCKST Lock bit status bit	0: Protected 1: Unprotected	(Note 1)	–
12–14	No function assigned. Fix to "0."		0	0
15	FRESET Flash reset bit	0: No operation 1: Reset	R	W

Note 1: Under setting FLOCKS bit of the flash control register 2 as "1" (register read mode), only the reading out value becomes effective after issuing read rock bit status command. The reading out value is undefined after issuing that read rock bit status command under setting FLOCKS bit as "0" (memory area read mode) and that other internal flash control command.

### (1) FLOCKST (Lock Bit Status) bit (Bit 11)

The FLOCKST bit is used to read the lock bit status. If the FLOCKST bit = "0," it means that the relevant memory block is protected. If the FLOCKST bit = "1," it means that the relevant memory block is not protected.

Confirmation of the lock bit status by the FLOCKST bit is possible when the FLOCKS bit = "1." In this case, the lock bit status can be checked by first issuing command data H'7171 and H'D0D0 to any address of the target block in succession and then, when the FBUSY bit is set to "1," by reading the FLOCKST bit.

### (2) FRESET (Flash Reset) bit (Bit 15)

The FRESET bit controls forcible termination of the internal flash memory programming/erase operation, initialization (to H'80) of each status bit in the Flash Status Register (FSTAT), and initialization of the FPBSYCK bit in Flash Control Register 3 (FCNT3).

Setting the FRESET bit to "1" forcibly terminates programming/erase operation and initializes each status bit in the FSTAT (to H'80) and the FPBSYCK bit in FCNT3. Make sure FRESET is held high (= "1") for at least 10  $\mu$ s during a flash reset.

After a flash reset, the internal flash memory is disabled against access until the FAENS bit is set to "1." The FRESET bit is effective only when the FENTRY bit = "1." Unless the FENTRY bit = "1," settings made to the FRESET bit are ignored. Make sure the FRESET bit = "0" while programming or erasing the flash memory.

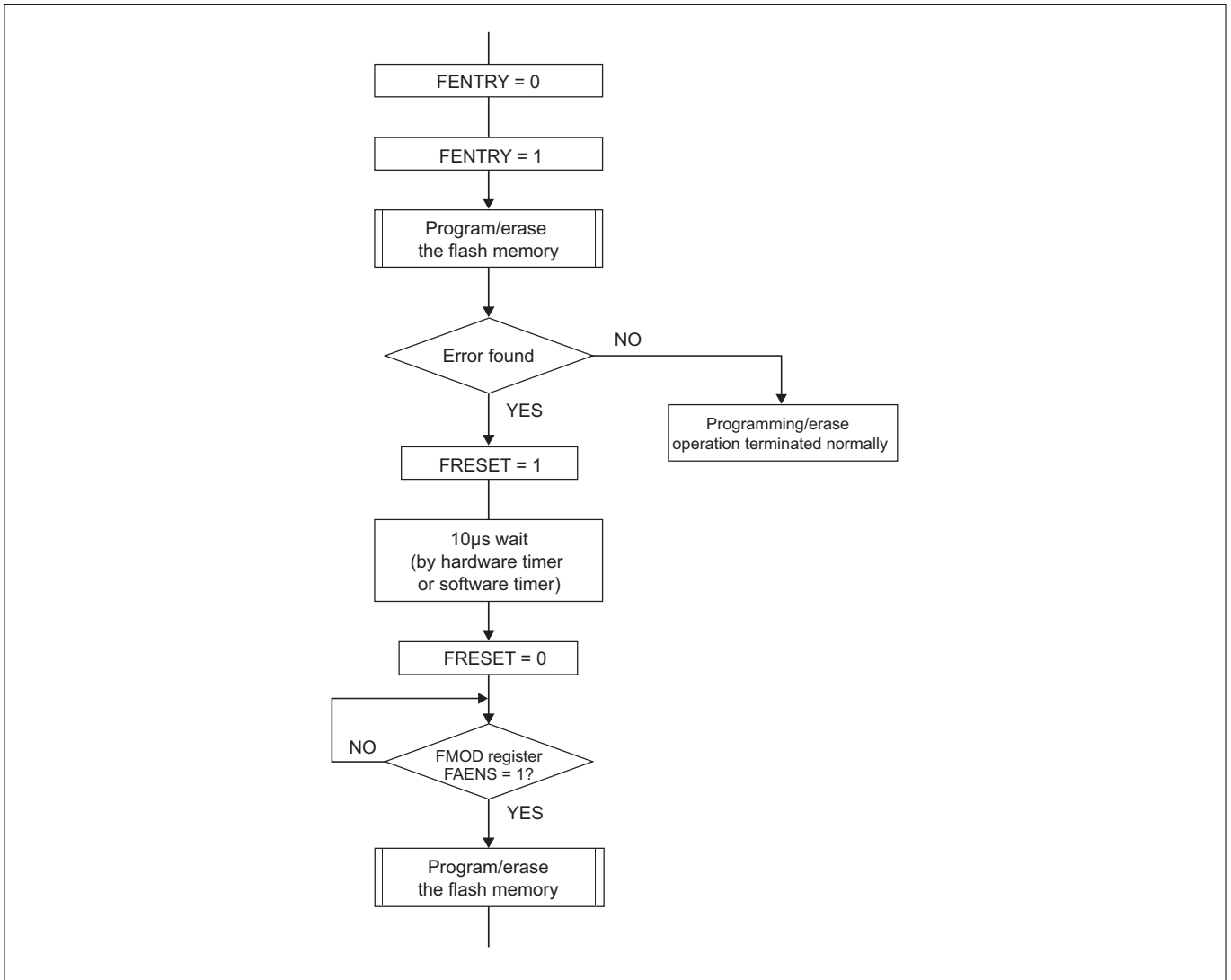


Figure 6.5.3 Example of FRESET Bit 1 (Initializing Flash Status Register 2)

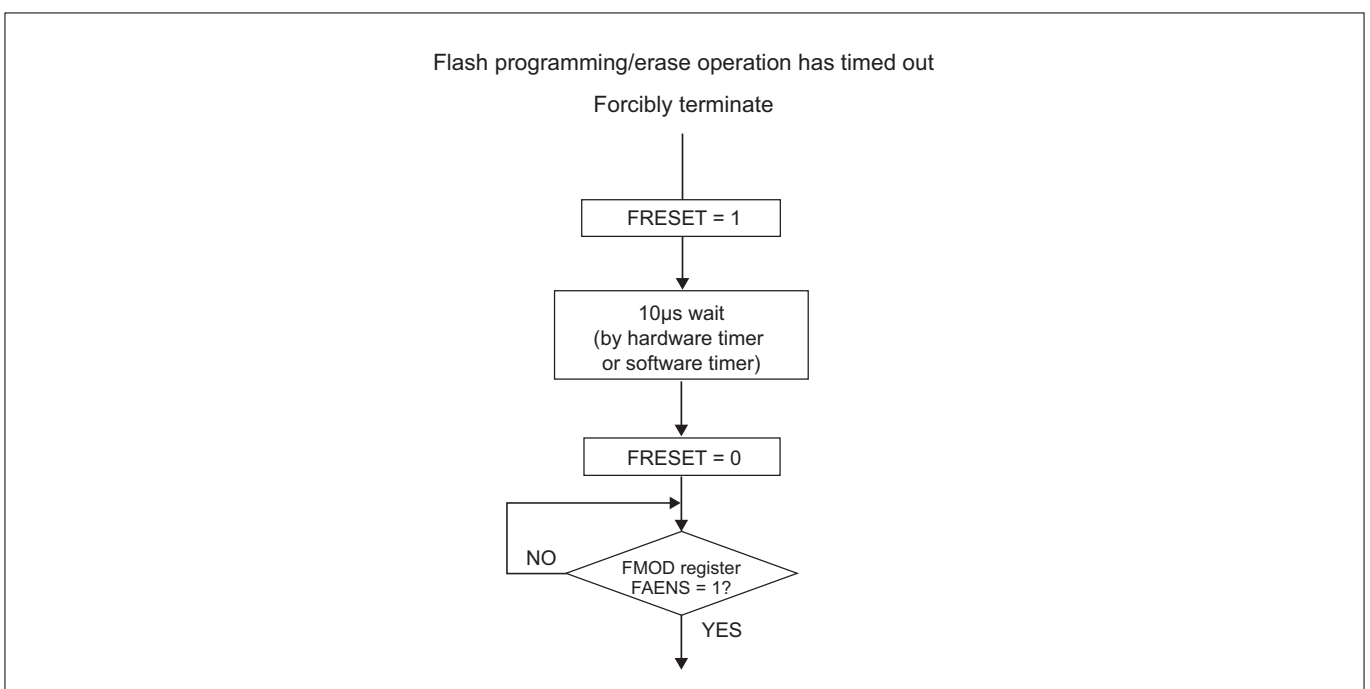
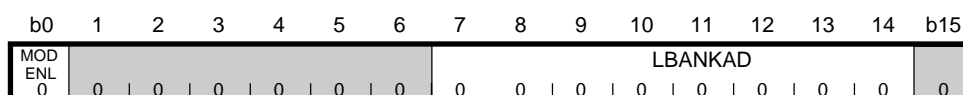


Figure 6.5.4 Example of FRESET Bit 2 (Forcibly Terminating Programming/Erasing Operation)

### 6.5.4 Virtual Flash L Bank Registers

Virtual Flash L Bank Register 0 (FELBANK0)	<Address: H'0080 07E8>
Virtual Flash L Bank Register 1 (FELBANK1)	<Address: H'0080 07EA>
Virtual Flash L Bank Register 2 (FELBANK2)	<Address: H'0080 07EC>
Virtual Flash L Bank Register 3 (FELBANK3)	<Address: H'0080 07EE>
Virtual Flash L Bank Register 4 (FELBANK4) (Note 3)	<Address: H'0080 07F0>
Virtual Flash L Bank Register 5 (FELBANK5) (Note 3)	<Address: H'0080 07F2>
Virtual Flash L Bank Register 6 (FELBANK6) (Note 3)	<Address: H'0080 07F4>
Virtual Flash L Bank Register 7 (FELBANK7) (Note 3)	<Address: H'0080 07F6>
Virtual Flash L Bank Register 8 (FELBANK8) (Note 2)	<Address: H'0080 07F8>
Virtual Flash L Bank Register 9 (FELBANK9) (Note 2)	<Address: H'0080 07FA>
Virtual Flash L Bank Register 10 (FELBANK10) (Note 2)	<Address: H'0080 07FC>
Virtual Flash L Bank Register 11 (FELBANK11) (Note 2)	<Address: H'0080 07FE>
Virtual Flash L Bank Register 12 (FELBANK12) (Note 2)	<Address: H'0080 0800>
Virtual Flash L Bank Register 13 (FELBANK13) (Note 2)	<Address: H'0080 0802>
Virtual Flash L Bank Register 14 (FELBANK14) (Note 2)	<Address: H'0080 0804>
Virtual Flash L Bank Register 15 (FELBANK15) (Note 2)	<Address: H'0080 0806>



<Upon exiting reset: H'0000>

b	Bit Name	Function	R	W
0	MODENL Virtual flash emulation L enable bit	0: Disable virtual flash emulation function 1: Enable virtual flash emulation function	R	W
1–6	No function assigned. Fix to "0."		0	0
7–14	LBANKAD L bank address bit (Note 1)	Start address A11–A18 of the relevant L bank	R	W
15	No function assigned. Fix to "0."		0	0

Note 1: Because the internal flash memory of the M32192F8 and M32196F8 are 1M (1024K) bytes, the address b7 (A11) must always be set to "0." Also, because the internal flash memory of the M32195F4 is 512 Kbytes, the address b7(A11) and b5(A12) must always be set to "0."

Note 2: This area exists only in the 32192 and it is use prohibition area in the 32195/32196.

Note 3: This area exists only in the 32192/32196 and it is use prohibition area in the 32195.

Note: • These registers must always be accessed in halfwords.

#### (1) MODENL (Virtual Flash Emulation L Enable) /bit (Bit 0)

The MODENL bit can be set to "1" after entering virtual flash emulation mode (by setting the FEMMOD bit to "1" while the FENTRY bit = "0"). This causes the virtual flash emulation function to be enabled for the L bank area selected by the LBANKAD bits.

#### (2) LBANKAD (L Bank Address) bits (Bits 7–14)

The LBANKAD bits are provided for selecting one of the L banks that are separated every 8 Kbytes. Use these LBANKAD bits to set the eight bits A11–A18 (b7 corresponds to the address A11 and b14 corresponds to the address A18) of the 32-bit start address of the desired L bank.

Note: • For details, see Section 6.7, "Virtual Flash Emulation Function."

## 6.6 Programming the Internal Flash Memory

### 6.6.1 Outline of Internal Flash Memory Programming

To program or erase the internal flash memory, there are following two methods to choose depending on the situation:

- (1) When the flash write/erase program does not exist in the internal flash memory
- (2) When the flash write/erase program already exists in the internal flash memory

For (1), set the FP pin = "H," MOD0 = "H" and MOD1 = "L" to enter boot mode. In this case, the CPU starts running the boot program upon exiting the reset state.

The boot program transfers the flash write/erase program into the internal RAM. After the transfer, jump to a location in the RAM and use the RAM-resident program to set the Flash Control Register 1 (FCNT1) FENTRY bit to "1" to make the internal flash memory ready for programming/erase operation (i.e., placed in boot mode + flash E/W enable mode).

When the above is done, use the flash write/erase program that has been transferred into the internal RAM to program or erase the internal flash memory.

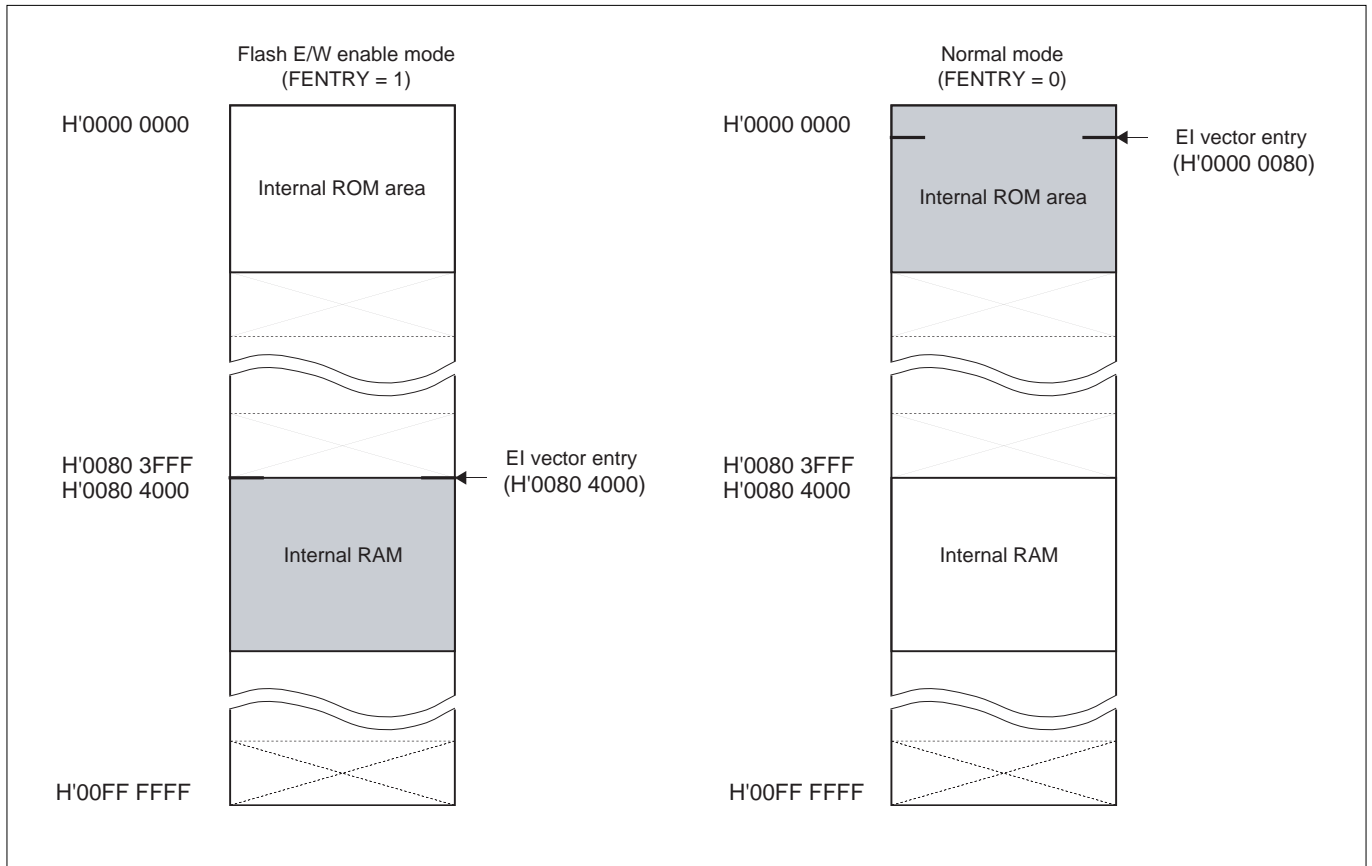
For (2), set the FP pin = "H," MOD0 = "L" and MOD1 = "L" to enter single-chip mode. Transfer the flash write/erase program from the internal flash memory in which it has been prepared into the internal RAM. After the transfer, jump to the RAM and use the program transferred into the RAM to set the Flash Control Register 1 (FCNT1) FENTRY bit to "1" to make the internal flash memory ready for programming/erase operation (i.e., placed in single-chip mode + flash E/W enable mode).

When the above is done, use the flash write/erase program that has been transferred into the internal RAM to program or erase the internal flash memory. Or flash E/W enable mode can be entered from external extension mode by setting the FP pin = "H," MOD0 = "L" and MOD1 = "H."

During flash E/W enable mode (FP pin = "H", FENTRY = "1"), the EIT vector entry for External Interrupt (EI) is relocated to the start address (H'0080 4000) of the internal RAM. During normal mode, it is located in the flash area (H'0000 0080).

To use an external interrupt (EI) in flash E/W enable mode, write at the beginning of the internal RAM an instruction for branching to the external interrupt (EI) handler that has been transferred into the internal RAM. Furthermore, because the IVECT register which is read out in the external interrupt (EI) handler has stored in it the flash memory address of the ICU vector table, make sure the ICU vector table to be used during flash E/W enable mode is prepared in the internal RAM so that the value of the IVECT register will be converted into the internal RAM address of the ICU vector table (for example, by adding an offset) before performing branch processing.

When started by boot mode, internal RAM value is indefinite after started by boot mode in order to "Flash writing/erasing program" is transferred to internal RAM.



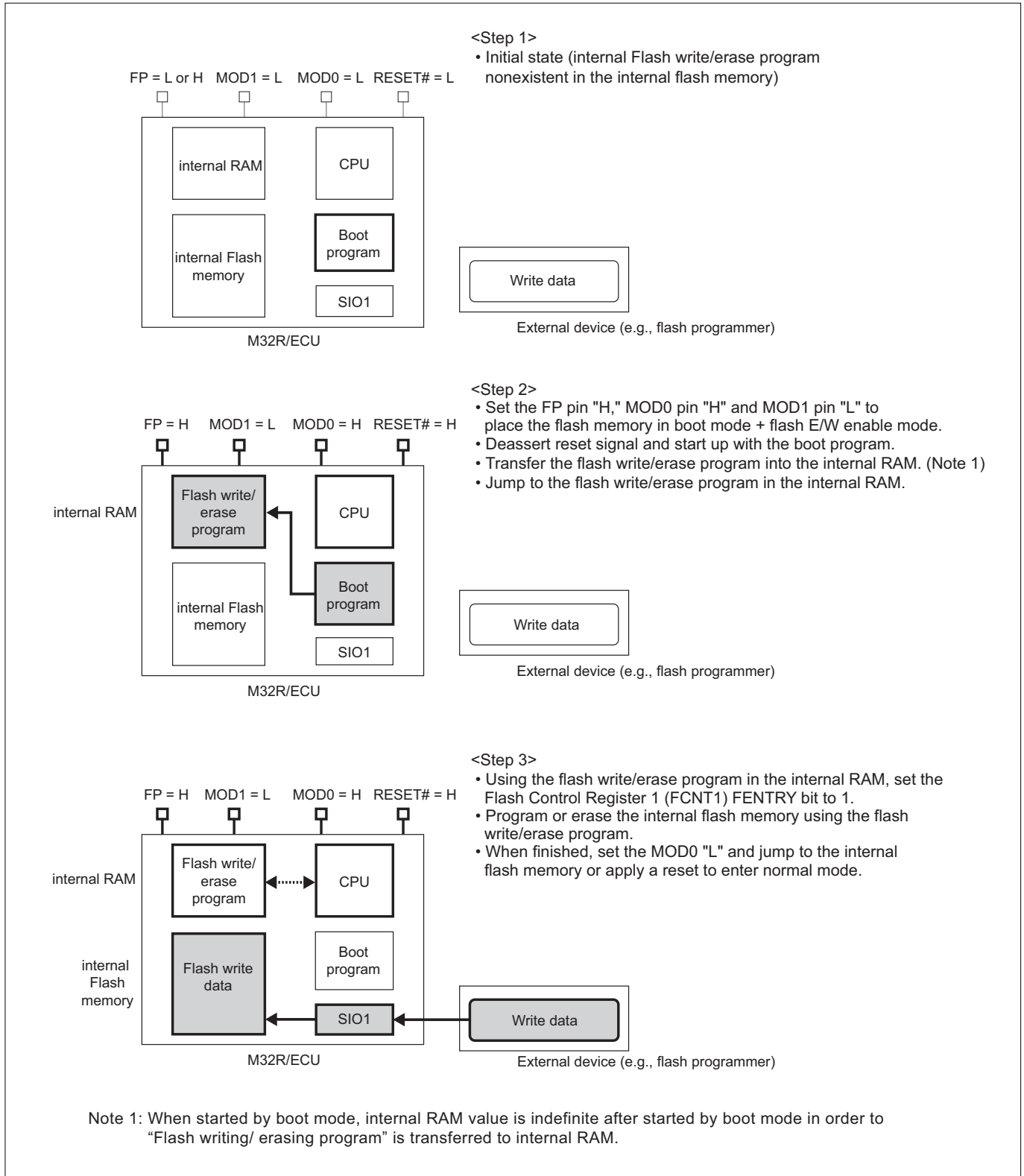
**Figure 6.6.1 EI Vector Entry during Flash E/W Enable Mode**



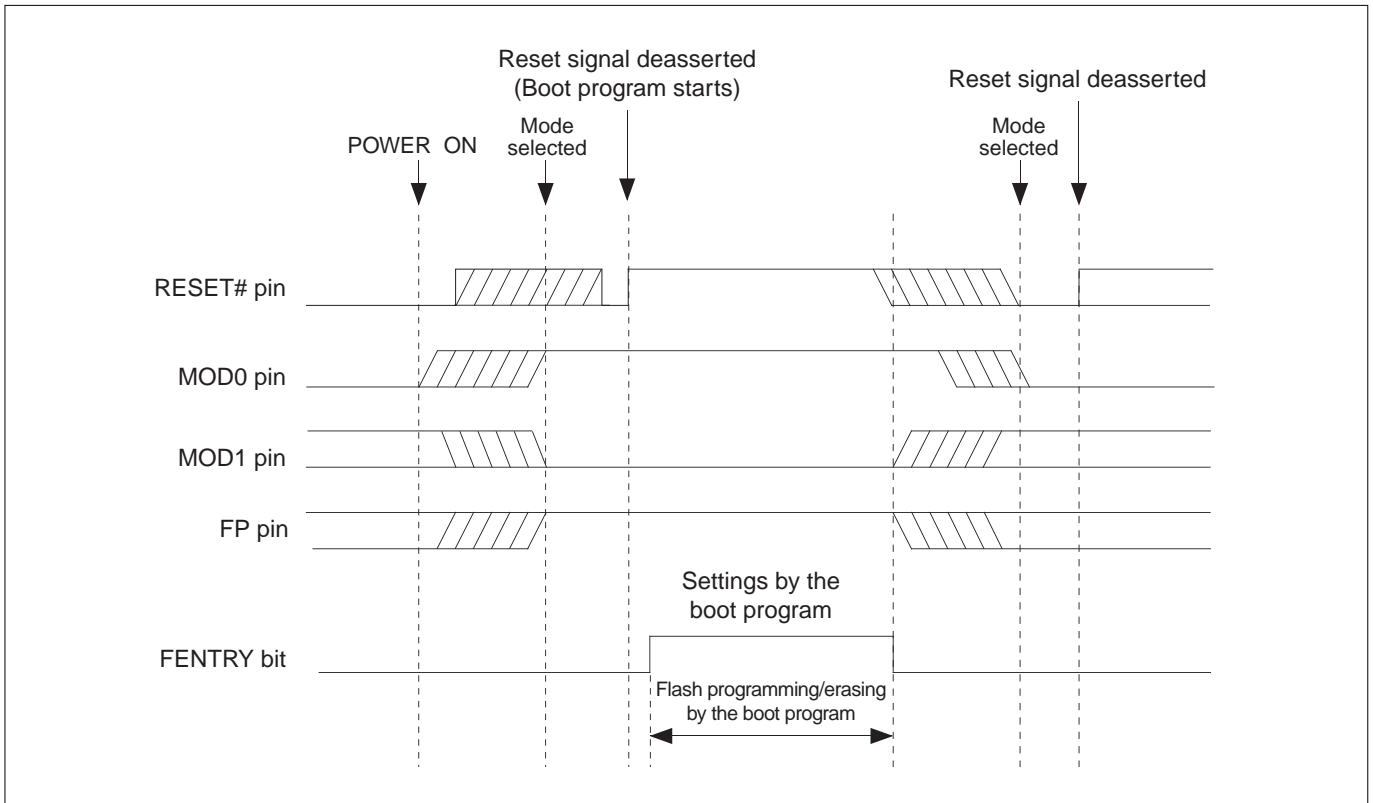
**(1) When the flash write/erase program does not exist in the internal flash memory**

In this case, the boot program is used to program or erase the internal flash memory. To transfer the write data, use SIO1 of serial interface 1 in clock-synchronous serial interface, or clock-asynchronous serial interface mode.

To program or erase the internal flash memory using a flash programmer, follow the procedure described below.



**Figure 6.6.2 Procedure for Programming/Erasing the Internal Flash Memory (when the flash write/erase program does not exist in it)**



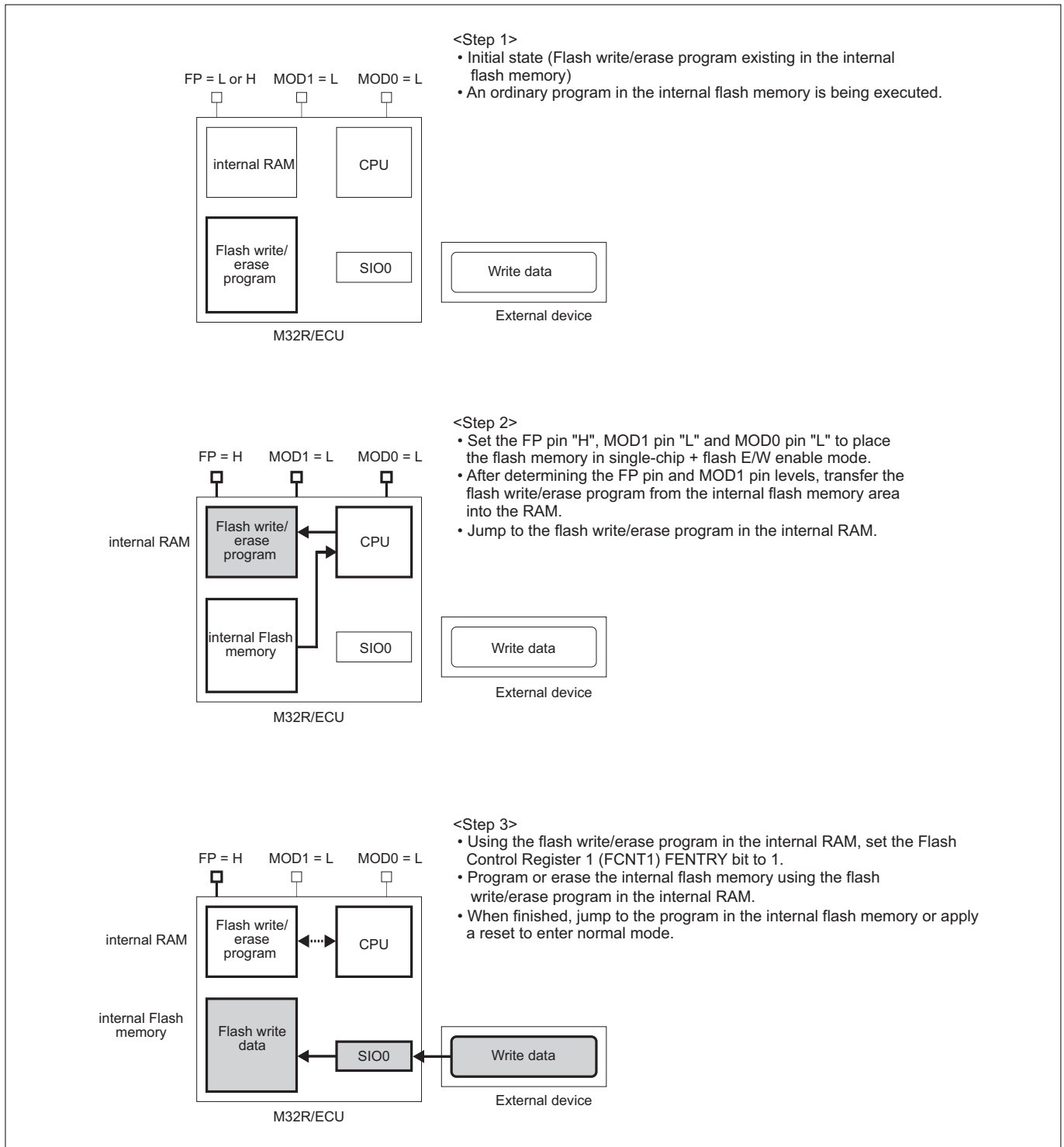
**Figure 6.6.3 Internal Flash Memory Write/Erase Timing (when the flash write/erase program does not exist in it)**

**(2) When the flash write/erase program already exists in the internal flash memory**

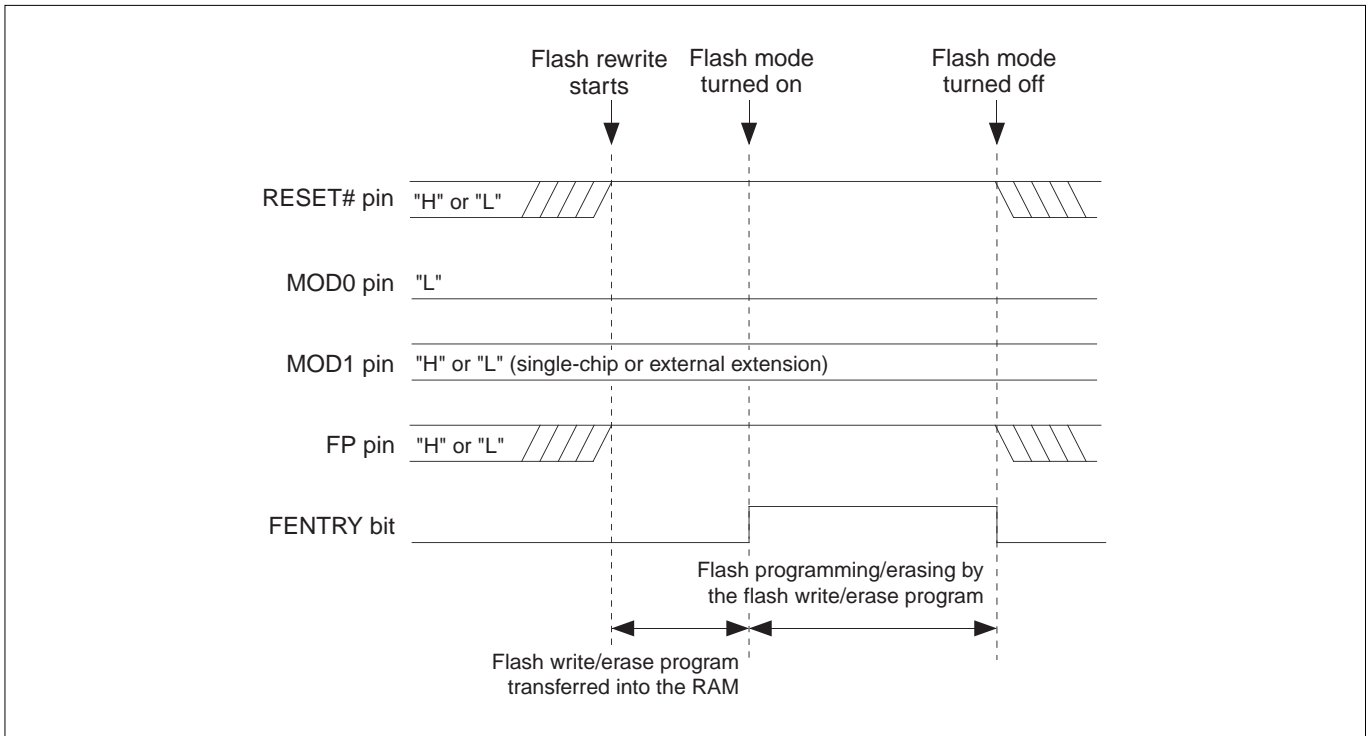
In this case, the flash write/erase program prepared in the internal flash memory is used to program or erase the internal flash memory.

For programming/erase operation here, use the internal peripheral circuits in the manner suitable for the programming system. (All resources of the internal peripheral circuits such as the data bus, serial interface and ports can be used.)

The following shows an example for programming or erasing the internal flash memory by using SIO0 in single-chip mode.



**Figure 6.6.4 Procedure for Programming/Erasing the Internal Flash Memory (when the flash write/erase program already exists in it)**



**Figure 6.6.5 Internal Flash Memory Write/Erase Control Pin Timing (when the flash write/erase program already exists in it)**

### 6.6.2 Controlling Operation Modes during Flash Programming

The microcomputer's operation mode is set by MOD0, MOD1 and Flash Control Register 1 (FCNT1) FENTRY bit. The table below lists operation modes that may be used when programming or erasing the internal flash memory.

**Table 6.6.1 Operation Modes Set during Flash Programming/Erase**

FP	MOD0	MOD1	FENTRY (Note 1)	Operation Mode	Reset Vector Entry	EI Vector Entry
0	0	0	0	Single-chip mode	Start address of internal flash memory (H'0000 0000)	Flash area (H'0000 0080)
1	0	0	0			
0	1	0	0	Processor mode	Start address of external area (H'0000 0000)	External area (H'0000 0080)
0	0	1	0	External extension mode	Start address of internal flash memory (H'0000 0000)	Flash area (H'0000 0080)
1	0	1	0			
1	0	0	1	Single-chip mode + flash E/W enable	Start address of internal flash memory (H'0000 0000)	Beginning of internal RAM (H'0080 4000)
1	1	0	0	Boot mode	Boot program startup address	Flash area (H'0000 0080)
1	1	0	1	Boot mode + flash E/W enable	Boot program startup address	Beginning of internal RAM (H'0080 4000)
1	0	1	1	External extension mode + flash E/W enable	Start address of internal flash memory (H'0000 0000)	Beginning of internal RAM (H'0080 4000)
–	1	1	–	Setting inhibited	–	–

Note 1: Indicates the Flash Control Register 1 (FCNT1) FENTRY bit status (– denotes "Don't care"). However, if FP = "0," writing "1" to FENTRY only results in it cleared to "0."

Note: • Always make sure the MOD2 pin is connected low (= 0) to ground (GND).

**(1) Flash E/W enable mode**

Flash E/W enable mode is a mode in which the internal flash memory can be programmed or erased. In flash E/W enable mode, no programs can be executed in the internal flash memory. Therefore, the necessary program must be transferred into the internal RAM before entering flash E/W enable mode, so that it can be executed in the RAM.

**(2) Entering flash E/W enable mode**

Flash E/W enable mode can only be entered when operating in single-chip, external extension or boot mode. Furthermore, it is only when the FP pin = "H" and the Flash Control Register 1 (FCNT1) FENTRY bit = "1" that flash E/W enable mode can be entered. Flash E/W enable mode cannot be entered when operating in processor mode or the FP pin = "L."

**(3) Detecting the MOD0 and MOD1 pin levels**

The MOD0 and MOD1 pin levels ("H" or "L") can be known by checking the P8 Data Register (Port Data Register, H'0080 0708) MOD0DT and MOD1DT bits.

P8 Data Register (P8DATA)

<Address: H'0080 0708>

b0	1	2	3	4	5	6	b7
MOD0DT	MOD1DT	P82DT	P83DT	P84DT	P85DT	P86DT	P87DT
?	?	?	?	?	?	?	?

<Upon exiting reset: Undefined>

b	Bit Name	Function	R	W
0	MOD0DT (P80DT) MOD0 data bit	0: MOD0 pin = "L" 1: MOD0 pin = "H"	R	-
1	MOD1DT (P81DT) MOD1 data bit	0: MOD1 pin = "L" 1: MOD1 pin = "H"	R	-
2	P82DT Port P82 data bit	At read Depends on how the Port Direction Register is set	R	W
3	P83DT Port P83 data bit	• If direction bit = "0" (input mode) 0: Port input pin = "L"		
4	P84DT Port P84 data bit	1: Port input pin = "H"		
5	P85DT Port P85 data bit	• If direction bit = "1" (output mode) (Note 1) 0: Port output latch = "0" / Port pin level = "L" 1: Port output latch = "1" / Port pin level = "H"		
6	P86DT Port P86 data bit	At write Write to the port output latch		
7	P87DT Port P87 data bit			

Note 1: To select the port data to read, use the Port Input Special Function Control Register's port input data select bit (PISEL).

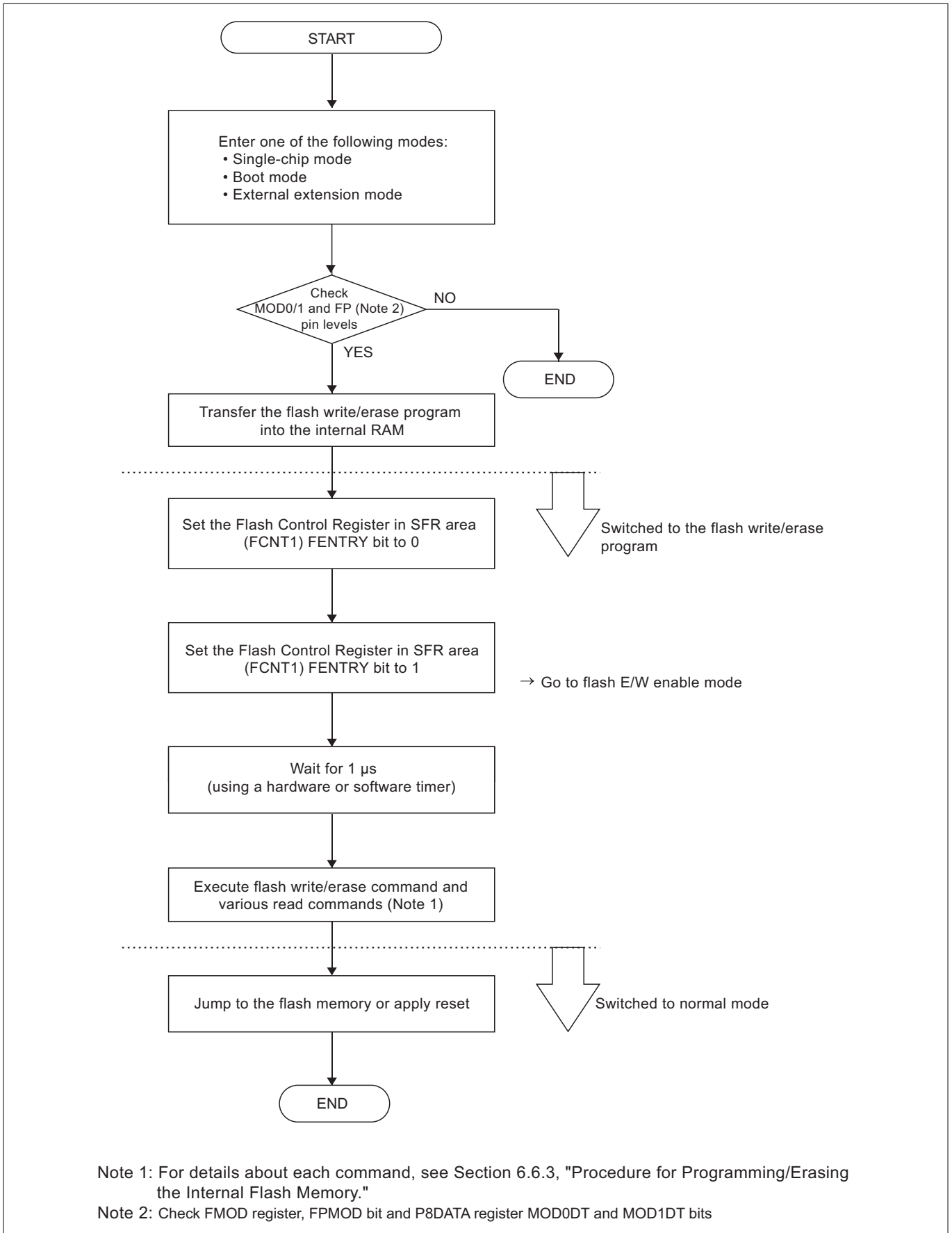


Figure 6.6.6 Procedure for Entering Flash E/W Enable Mode

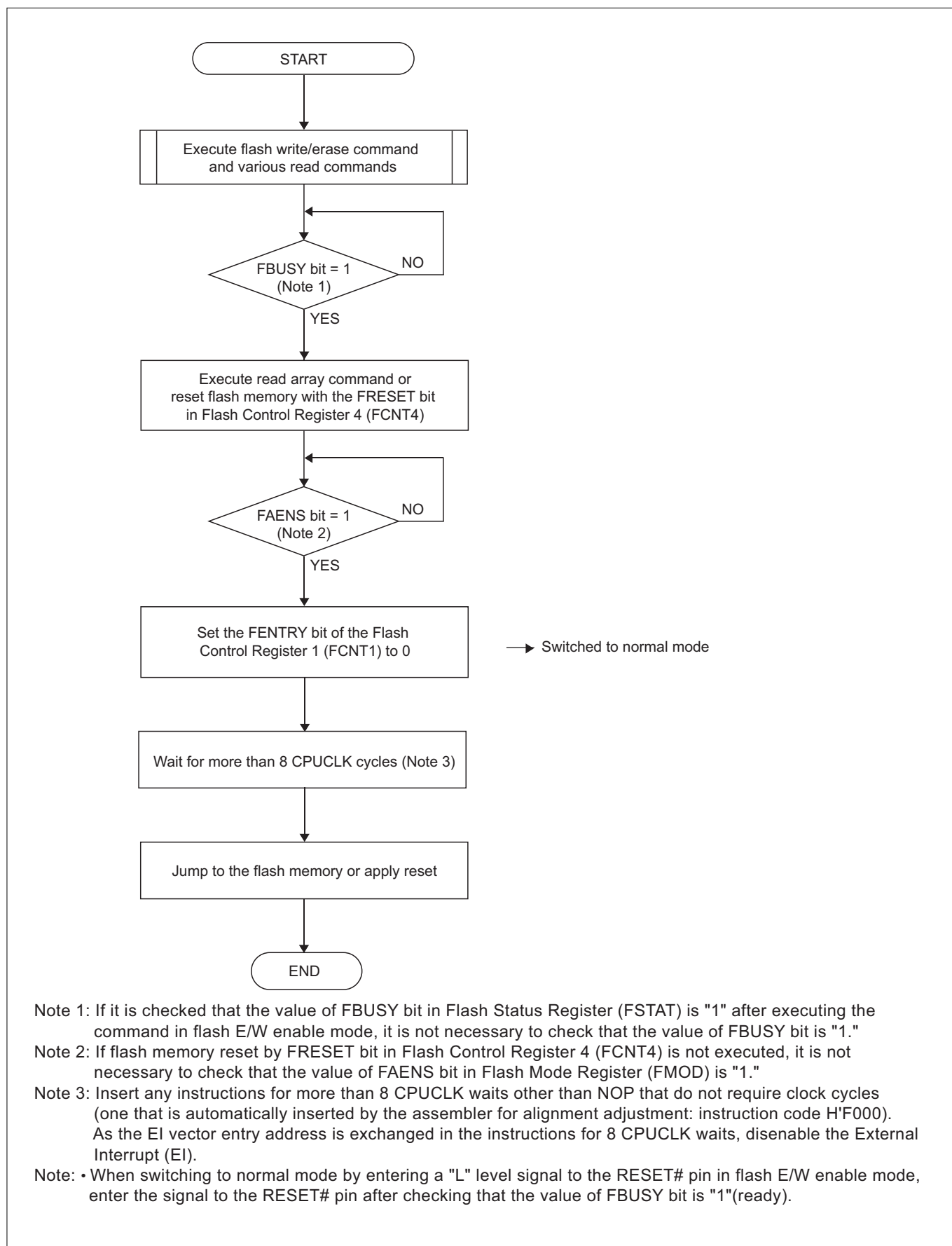


Figure 6.6.7 Procedure for Entering Normal Mode



### 6.6.3 Procedure for Programming/Erasing the Internal Flash Memory

To program or erase the internal flash memory, set up chip mode to enter flash E/W enable mode and execute the flash write/erase program in the internal RAM into which it has been transferred from the internal flash memory.

In flash E/W enable mode, because the internal flash memory cannot be accessed for read as in normal mode, no programs present in it can be executed. Therefore, the flash write/erase program must be made available in the internal RAM before entering flash E/W enable mode. (Once flash E/W enable mode is entered into, only flash command and no other commands can be used to access the internal flash memory.)

To access the internal flash memory in flash E/W enable mode, issue commands for the internal flash memory address to be operated on. The table below lists the commands that can be issued in flash E/W enable mode.

Note: • During flash E/W enable mode, the internal flash memory cannot be accessed for read or write wordwise.

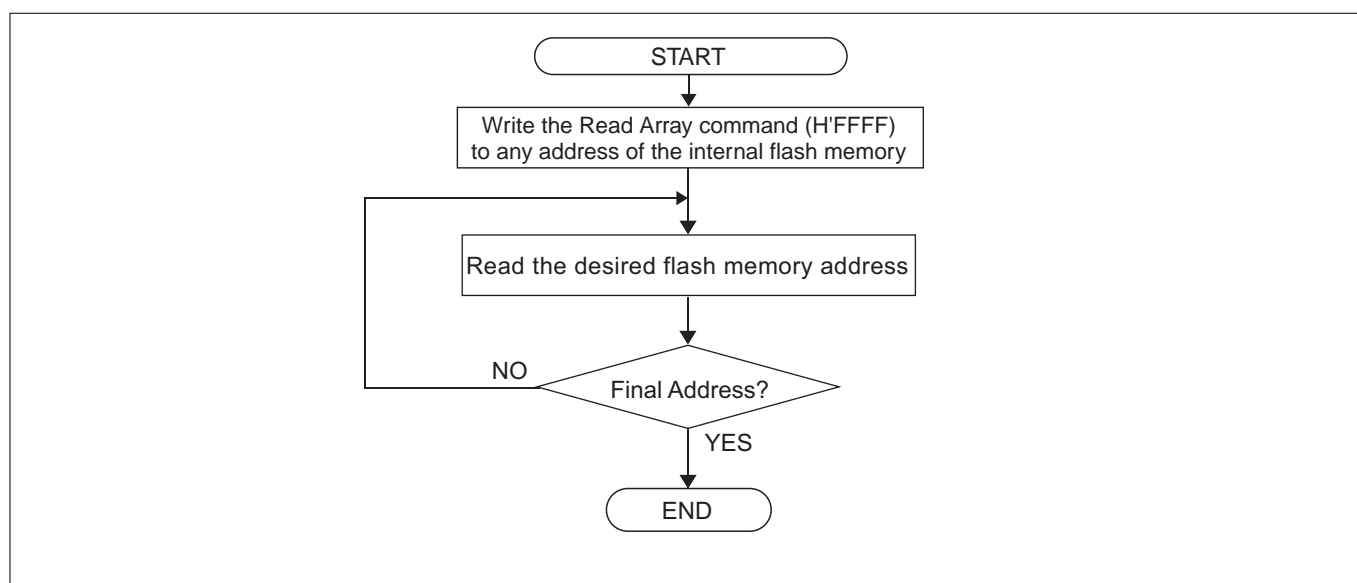
**Table 6.6.2 Commands in Flash E/W Enable Mode**

Command Name	Issued Command Data
Read Array command	H'FFFF
4 Halfword Program command	H'4343
Lock Bit Program command	H'7777
Block Erase command	H'2020
Clear Status Register command	H'5050
Read Lock Bit Status command	H'7171
Verify command (Note 1)	H'D0D0

Note 1: This command must be issued immediately after the Lock Bit Program, Block Erase or Read Lock Bit Status command. If the Lock Bit Program, Block Erase or Read Lock Bit Status command is followed by other than the Verify (H'D0D0) command, the Lock Bit Program, Block Erase or Read Lock Bit Status command is not executed normally and terminated in error.

#### (1) Read Array command

Writing the Read Array command (H'FFFF) to any address of the internal flash memory places it in read mode. Then read the desired flash memory address, and the content of that address will be read out. Before exiting flash E/W enable mode, always be sure to execute the Read Array command.



**Figure 6.6.8 Read Array**

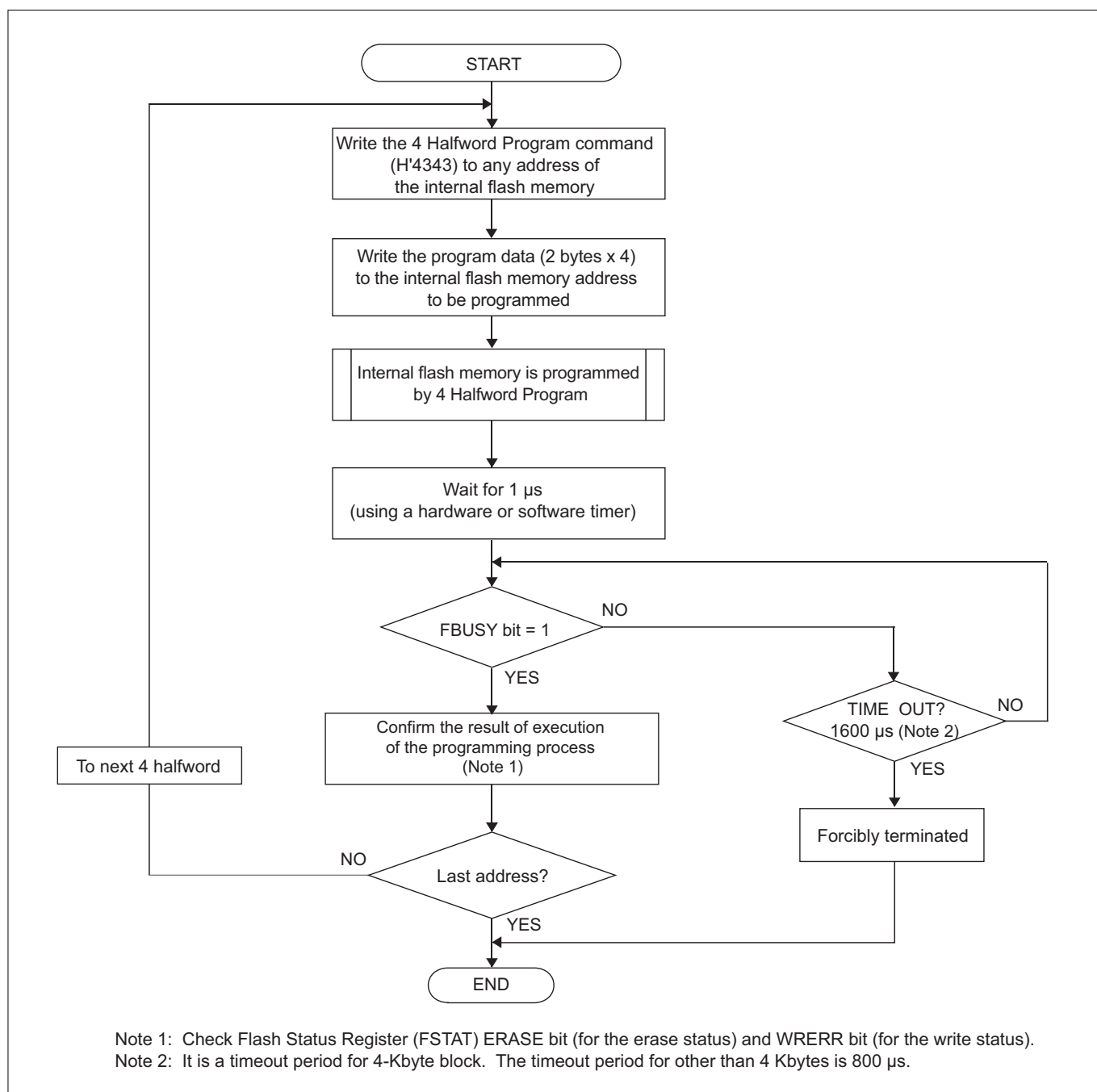
**(2) 4 Halfword Program command**

This command performs write (programming) to the flash memory in 4 halfword units (8-byte unit), or every 2 bytes (Half word) x 4 times. Also, the initial address at write must always be written with the address of 4 halfword boundary (low-order address, B'000).

To program data to the flash memory, write the Program command (H'4343) to any address of the internal flash memory, and then the program data to the address to be programmed.

The protected flash memory blocks cannot be accessed for write by the 4 Halfword Program command.

4 halfword programming is automatically performed by the internal control circuit, and whether the 4 Halfword Program command has finished can be known by checking the FBUSY (Flash Busy) bit in the Flash Status Register. While the FBUSY bit = "0," the next programming cannot be performed.



**Figure 6.6.9 4 Halfword Program**

**(3) Lock Bit Program command**

The internal flash memory can be protected against programming/erase operation one block at a time. The Lock Bit Program command is provided for protecting the flash memory blocks.

Write the Lock Bit Program command (H'7777) to any address of the internal flash memory. Next, write the Verify command (H'D0D0) to the last even address of the flash memory block to be protected, and this memory block is thereby protected against programming/erase operation. To remove protection, use the Flash Control Register 2 (FCNT2) FPROT (Rock bit Protect Control) bit to invalidate protection by a lock bit and erase the flash memory block whose protection is to be removed. (The content of that memory block is also erased.)

Lock bit programming is automatically performed by the internal control circuit, and whether the Lock Bit Program command has finished can be known by checking FBUSY (Flash Busy) bit in the Flash Status Register (FSTAT). While the FBUSY bit = "0," the next programming cannot be performed.

The table below lists the target flash memory blocks and their addresses to be specified when writing the Verify command data.

**Table 6.6.3 Target Blocks and Specified Addresses**

Target Block	Specified Address
0	H'0000 1FFE
1	H'0000 2FFE
2	H'0000 3FFE
3	H'0000 7FFE
4	H'0000 FFFE
5	H'0001 FFFE
6	H'0002 FFFE
7	H'0003 FFFE
8	H'0004 FFFE
9	H'0005 FFFE
10	H'0006 FFFE
11	H'0007 FFFE
12	H'0008 FFFE
13	H'0009 FFFE
14	H'000A FFFE
15	H'000B FFFE
16	H'000C FFFE
17	H'000D FFFE
18	H'000E FFFE
19	H'000F FFFE

Note: • Because the internal flash memory of the M32195F4 is 512 Kbytes, block 12 to block 19 do not exist.

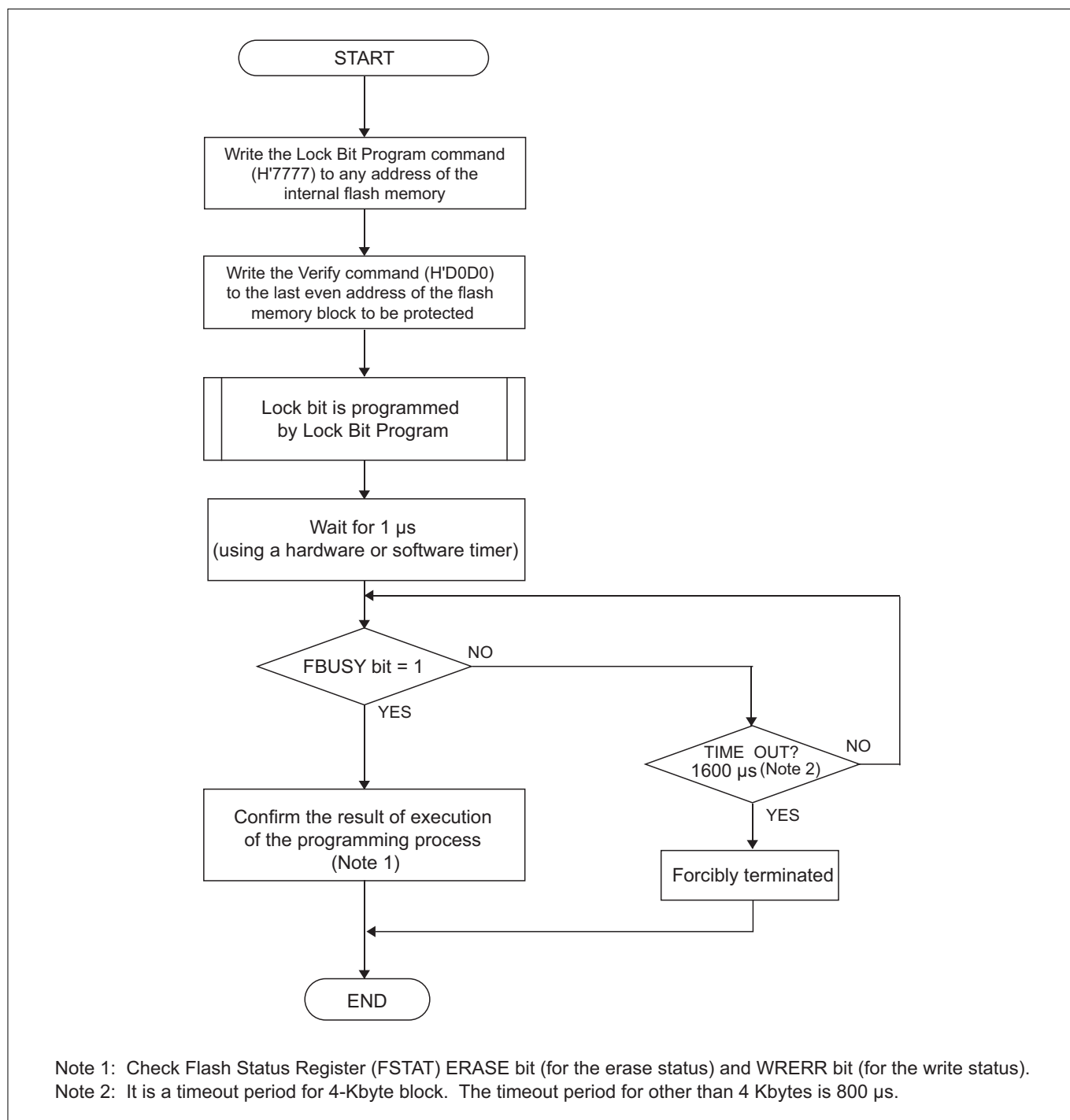


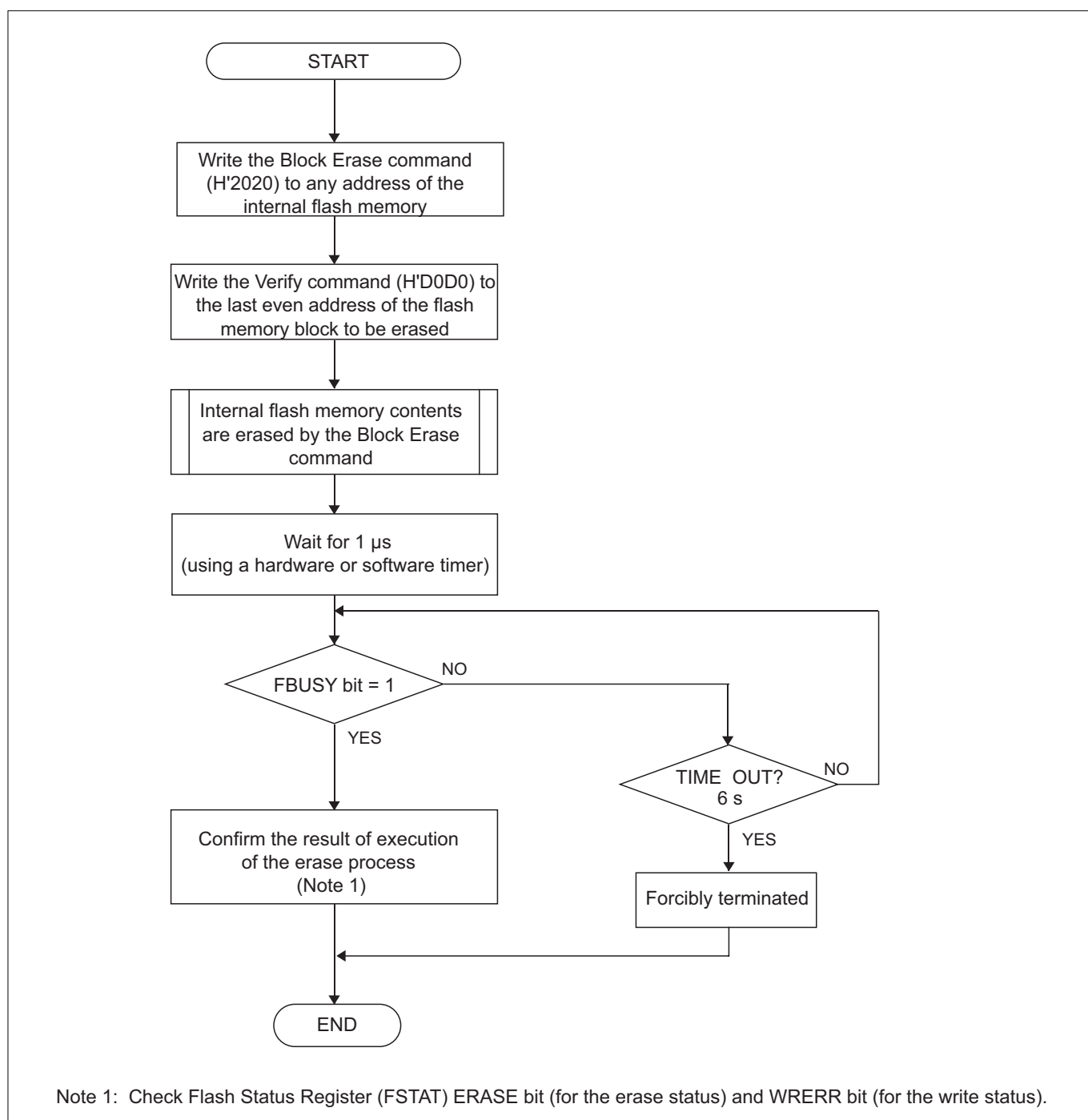
Figure 6.6.10 Lock Bit Program

**(4) Block Erase command**

The Block Erase command erases the content of the internal flash memory one block at a time. To perform this operation, write the command data (H'2020) to any address of the internal flash memory. Next, write the Verify command (H'D0D0) to the last even address of the flash memory block to be erased (see Table 6.6.3, "Target Blocks and Specified Addresses").

The protected flash memory blocks cannot be erased by the Block Erase command.

Block erase operation is automatically performed by the internal control circuit, and whether the Block Erase command has finished can be known by checking FBUSY (Flash Busy) bit in the Flash Status Register (FSTAT). While the FBUSY bit = "0," the next block erase operation cannot be performed.

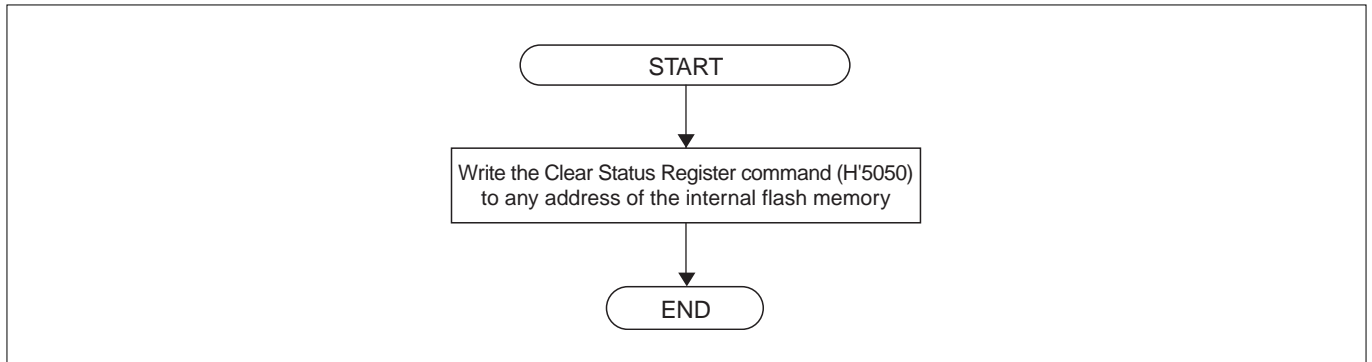


**Figure 6.6.11 Block Erase**

**(5) Clear Status Register command**

The Clear Status Register command clears the Flash Status Register (FSTAT) ERASE (erase status), and WRERR (write status) bits to "0." Write the command data (H'5050) to any address of the internal flash memory, and Flash Status Register is thereby initialized. Also, issue the Clear Status Register command, and Flash Status Register 3 (FCNT3) is initialized.

If an error occurs when programming or erasing the flash memory and the Flash Status Register (FSTAT) ERASE (erase status) or WRERR (write status) bit is set to "1," the next programming or erase operation cannot be executed unless each status bit is cleared to "0."



**Figure 6.6.12 Clear Status Register**

**(6) Read Lock Bit Status command**

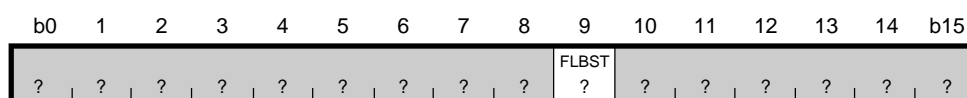
The Read Lock Bit Status command is provided for checking whether a flash memory block is protected against programming/erase operation. The method for reading lock bit can be chosen from the following depends on the setting for Flash Control Register 2 (FCNT2) FLOCKS (Lock bit read mode select) bit.

**1) Memory area read mode (FLOCKS bit = 0)**

Write the command data (H'7171) to any address of the internal flash memory. Next, read the last even address of the flash memory block to be checked (see Table 6.6.3, "Target Blocks and Specified Addresses"), and the read data shows whether the target block is protected.

If the FLBST (lock bit) in the read data is "0," it means that the target memory block is protected. If the FLBST (lock bit) is "1," it means that the target memory block is not protected.

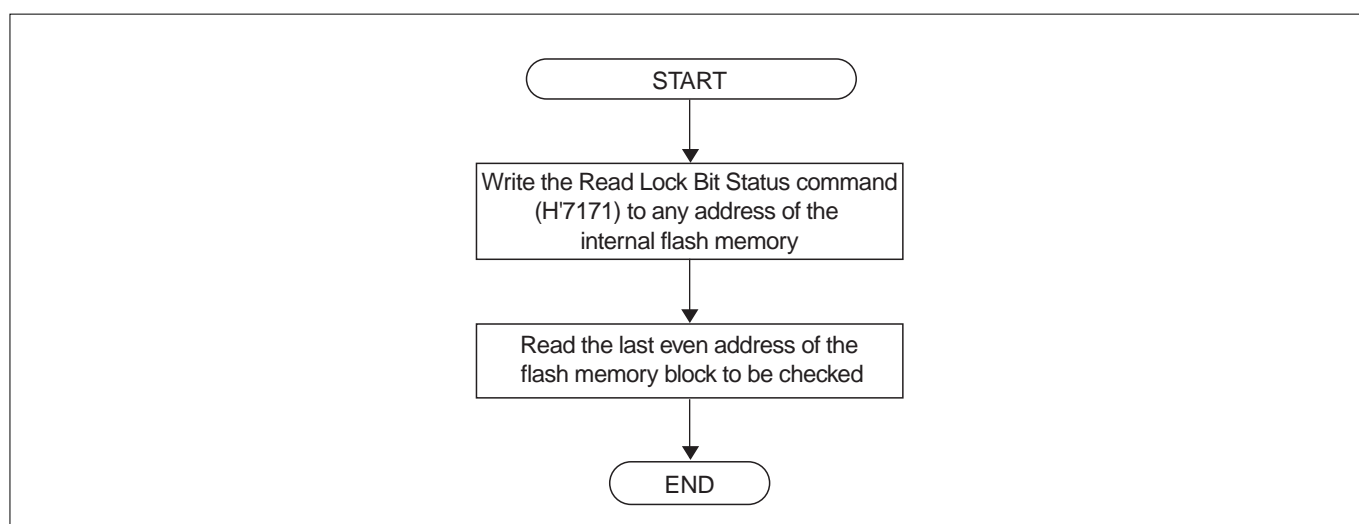
Lock Bit Status Register (FLBST)



<Upon exiting reset: Undefined>

b	Bit Name	Function	R	W
0–8	No function assigned.		?	0
9	FLBST Lock bit	0: Protected 1: Not protected	R	–
10–15	No function assigned.		?	0

The Lock Bit Status Register is a read-only register, which is included for each memory block independently of one another. To read this register, Flash Control Register 2 (FCNT2) FLOCKS bit must be set to "0."



**Figure 6.6.13 Read Lock Bit Status (Memory Area Read Mode)**

**2) Register read mode (FLOCKS bit = 1)**

Write the command data (H'7171) to any address of the target block. Next, write the verify command data (H'D0D0), and the Flash Control Register 4 (FCNT4) FLOCKST (Lock Bit Status) bit shows whether the target block is protected.

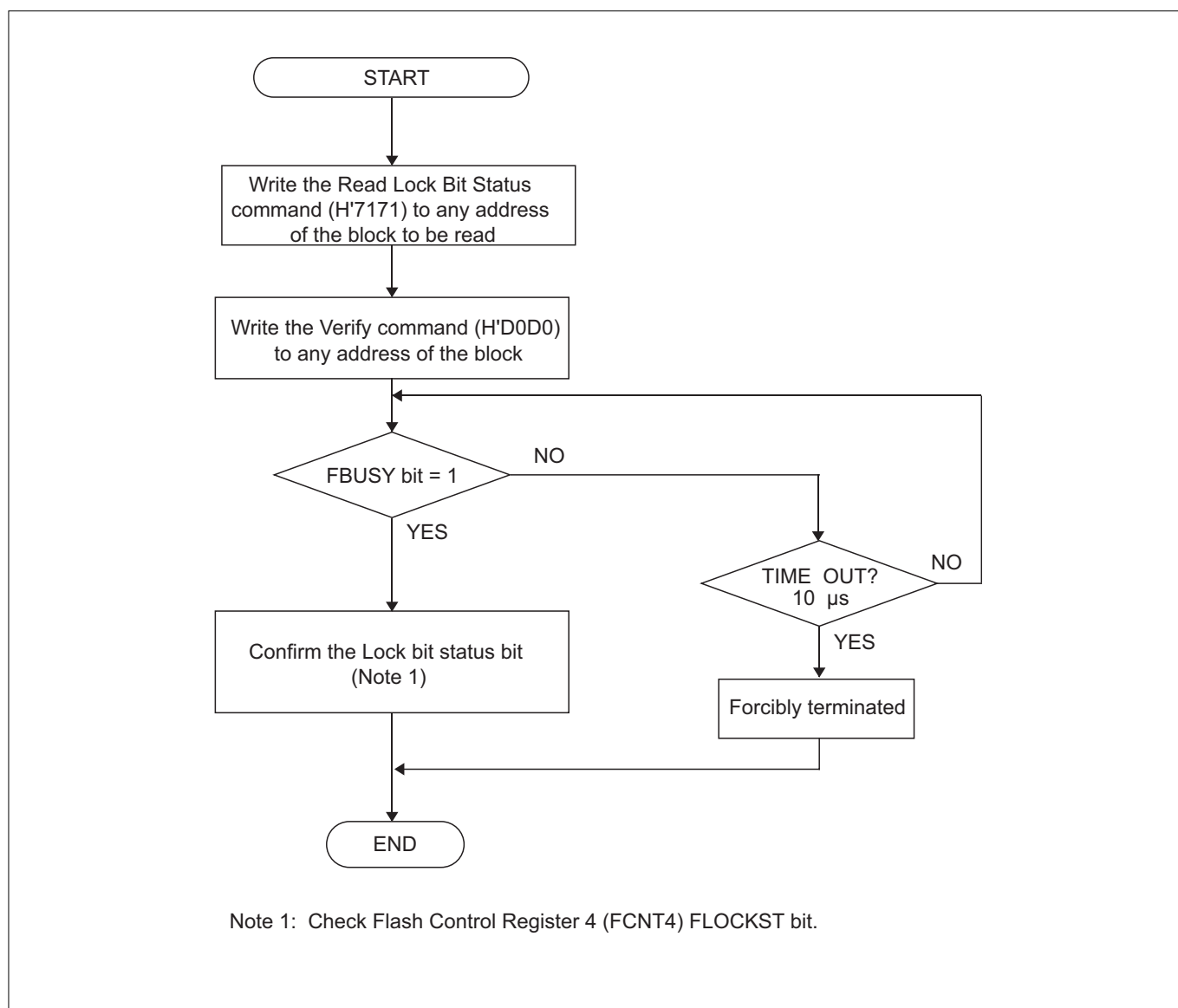


Figure 6.6.14 Read Lock Bit Status (Register Read Mode)

The following describes how to write to the lock bit.

**a) To clear the lock bit to "0" (flash protected)**

Issue the Lock Bit Program command (H'7777) to the memory block to be protected.

**b) To set the lock bit to "1" (flash unprotected)**

After setting the FPROT bit in Flash Control Register 2 to "1" (protection by lock bit disabled), use the Block Erase command (H'2020) to erase the memory block to be unprotected.

The lock bit cannot be set to "1" directly by writing to it.

**c) Lock bit status when reset**

Because the lock bit is a nonvolatile bit, it remains unaffected when the microcomputer is reset or powered off.



### 6.6.4 Flash Programming Time (Reference)

The following shows the time needed to program internal flash memory for reference.

#### (1) M32192F8 and M32196F8

##### [1] Transfer time by SIO (When the capacity of transfer data : 1024KB)

$$1 / 57600\text{bps} \times 1(\text{fram}) \times 11(\text{the number of transfer bit}) \times 1024\text{KB} = \text{approx. } 200.2 \text{ [s]}$$

##### [2] Flash writing time

Other than 4KB block

$$(1024\text{KB} - 4\text{KB} \times 2) / 8\text{byte} \times 100\text{ms} = \text{approx. } 13.0 \text{ [s]}$$

4KB block

$$4\text{KB} \times 2 / 8\text{byte} \times 200\text{ms} = \text{approx. } 0.2 \text{ [s]}$$

Total 13.2 [s]

##### [3] Erase time (all areas)

$$0.3\text{s} \times 3\text{block} + 0.5\text{s} \times 1\text{block} + 0.7\text{s} \times 1\text{block} \times 1.2\text{s} \times 15\text{block} = 20.1 \text{ [s]}$$

##### [4] Total flash writing time (1024KB all areas)

During 57600bps connection, flash writing time to serial connection is so short that it is able to be ignored. For this reason, flash writing time is calculable with the following formula.

$$[1] + [3] = \text{approx. } 220.3 \text{ [s]}$$

In addition, the quickest data writing time with high speed is by speeding up serial connection or other means is calculable with the following formula.

$$[2] + [3] = \text{approx. } 33.3 \text{ [s]}$$

#### (2) M32195F4

##### [1] Transfer time by SIO (When the capacity of transfer data : 512KB)

$$1 / 57600\text{bps} \times 1(\text{fram}) \times 11(\text{the number of transfer bit}) \times 512\text{KB} = \text{approx. } 100.1 \text{ [s]}$$

##### [2] Flash writing time

Other than 4KB block

$$(512\text{KB} - 4\text{KB} \times 2) / 8\text{byte} \times 100\text{ms} = \text{approx. } 6.5 \text{ [s]}$$

4KB block

$$4\text{KB} \times 2 / 8\text{byte} \times 200\text{ms} = \text{approx. } 0.2 \text{ [s]}$$

Total 6.7 [s]

##### [3] Erase time (all areas)

$$0.3\text{s} \times 3\text{block} + 0.5\text{s} \times 1\text{block} + 0.7\text{s} \times 1\text{block} \times 1.2\text{s} \times 7\text{block} = 10.5 \text{ [s]}$$

##### [4] Total flash writing time (512KB all areas)

During 57600bps connection, flash writing time to serial connection is so short that it is able to be ignored. For this reason, flash writing time is calculable with the following formula.

$$[1] + [3] = \text{approx. } 110.6 \text{ [s]}$$

In addition, the quickest data writing time with high speed is by speeding up serial connection or other means is calculable with the following formula.

$$[2] + [3] = \text{approx. } 17.2 \text{ [s]}$$

## 6.7 Virtual Flash Emulation Function

The microcomputer has the function to map 8-Kbyte memory blocks of the internal RAM (maximum for 32192 is 16 blocks, for 32195 is 4 blocks for 32196 is 8 blocks) into areas (L banks) of the internal flash memory that are divided in 8-Kbyte units. This functions is referred to as the Virtual Flash Emulation Function.

This function allows the data located in 8-Kbyte blocks of the internal RAM to be changed with the contents of internal flash memory at the addresses specified by the Virtual Flash L Bank Register. That way, the relevant internal RAM data can read out by reading the content of internal flash memory.

For applications that require modifying the contents of internal flash memory (e.g., data table) during operation, this function enables dynamic data modification by modifying the relevant internal RAM data.

The internal RAM blocks allocated for virtual flash emulation can be accessed for read and write the same way as in usual internal RAM.

This function, when used in combination with the microcomputer's internal Real-Time Debugger (RTD), allows the data table, etc. created in the internal flash memory to be referenced or rewritten from the outside, thereby facilitating data table tuning from an external device.

Note: • Before programming/erasing the internal flash memory, always be sure to exit this virtual flash emulation mode.

H'0080 4000	Unusable for virtual flash emulation function 48 Kbytes
H'0080 FFFF H'0081 0000	RAM bank L block 0 (FELBANK0) 8 Kbytes
H'0081 1FFF H'0081 2000	RAM bank L block 1 (FELBANK1) 8 Kbytes
H'0081 3FFF H'0081 4000	RAM bank L block 2 (FELBANK2) 8 Kbytes
H'0081 5FFF H'0081 6000	RAM bank L block 3 (FELBANK3) 8 Kbytes
H'0081 7FFF H'0081 8000	RAM bank L block 4 (FELBANK4) 8 Kbytes
H'0081 9FFF H'0081 A000	RAM bank L block 5 (FELBANK5) 8 Kbytes
H'0081 BFFF H'0081 C000	RAM bank L block 6 (FELBANK6) 8 Kbytes
H'0081 DFFF H'0081 E000	RAM bank L block 7 (FELBANK7) 8 Kbytes
H'0081 FFFF H'0082 0000	RAM bank L block 8 (FELBANK8) 8 Kbytes
H'0082 1FFF H'0082 2000	RAM bank L block 9 (FELBANK9) 8 Kbytes
H'0082 3FFF H'0082 4000	RAM bank L block 10 (FELBANK10) 8 Kbytes
H'0082 5FFF H'0082 6000	RAM bank L block 11 (FELBANK11) 8 Kbytes
H'0082 7FFF H'0082 8000	RAM bank L block 12 (FELBANK12) 8 Kbytes
H'0082 9FFF H'0082 A000	RAM bank L block 13 (FELBANK13) 8 Kbytes
H'0082 BFFF H'0082 C000	RAM bank L block 14 (FELBANK14) 8 Kbytes
H'0082 DFFF H'0082 E000	RAM bank L block 15 (FELBANK15) 8 Kbytes
H'0082 FFFF	

Figure 6.7.1 Internal RAM Bank Configuration of the 32192

H'0080 4000	RAM bank L block 0 (FELBANK0) 8 Kbytes
H'0080 5FFF	
H'0080 6000	RAM bank L block 1 (FELBANK1) 8 Kbytes
H'0080 7FFF	
H'0080 8000	RAM bank L block 2 (FELBANK2) 8 Kbytes
H'0080 9FFF	
H'0080 A000	RAM bank L block 3 (FELBANK3) 8 Kbytes
H'0080 BFFF	

Figure 6.7.2 Internal RAM Bank Configuration of the 32195

H'0080 4000	RAM bank L block 0 (FELBANK0) 8 Kbytes
H'0080 5FFF	
H'0080 6000	RAM bank L block 1 (FELBANK1) 8 Kbytes
H'0080 7FFF	
H'0080 8000	RAM bank L block 2 (FELBANK2) 8 Kbytes
H'0080 9FFF	
H'0080 A000	RAM bank L block 3 (FELBANK3) 8 Kbytes
H'0080 BFFF	
H'0080 C000	RAM bank L block 4 (FELBANK4) 8 Kbytes
H'0080 DFFF	
H'0080 E000	RAM bank L block 5 (FELBANK5) 8 Kbytes
H'0080 FFFF	
H'0081 0000	RAM bank L block 6 (FELBANK6) 8 Kbytes
H'0081 1FFF	
H'0081 2000	RAM bank L block 7 (FELBANK7) 8 Kbytes
H'0081 3FFF	

Figure 6.7.3 Internal RAM Bank Configuration of the 32196

## 6.7.1 Virtual Flash Emulation Area

Figure 6.7.1 to Figure 6.7.3 show the internal flash memory areas in which the Virtual Flash Emulation Function is applicable.

Using the Virtual Flash L Bank Register (M32192 F8: FELBANK0 to FELBANK15, M32195F4: FELBANK0 to FELBANK3, M32196F8: FELBANK0 to FELBANK7), select one among all L banks of internal flash memory that are divided in 8-Kbyte units (by setting the eight start address bits A11–A18 of the desired L bank in the Virtual Flash L Bank Register LBANKAD bits). Then set the Virtual Flash L Bank Register's flash emulation L enable bit (MODENL) to "1," and the selected L bank area will be replaced with 8-Kbyte blocks of the internal RAM, (maximum for 32192 is 16 blocks, for 32195 is 4 blocks, for 32196 is 8 blocks).

- Notes:
- If the same bank area is set in two or more Virtual Flash L Bank Registers and accessed while each register's flash emulation enable bit is enabled, the data will be destroyed. Therefore, do not set the same bank area in two or more registers.
  - During virtual flash emulation mode, RAM can be accessed for read and write from the internal RAM area and the virtual flash set area.
  - Before reading any virtual flash set area after setting the Flash Control Register 1 virtual flash emulation mode bit to "1," be sure to check that the virtual flash emulation mode bit has been set to "1" by reading it once.
  - Before reading any virtual flash set area after setting the Virtual Flash L Bank Register virtual flash emulation L enable bit and L bank address bits, be sure to check that the virtual flash emulation L enable bit and L bank address bits have been set to the intended values by reading them once.

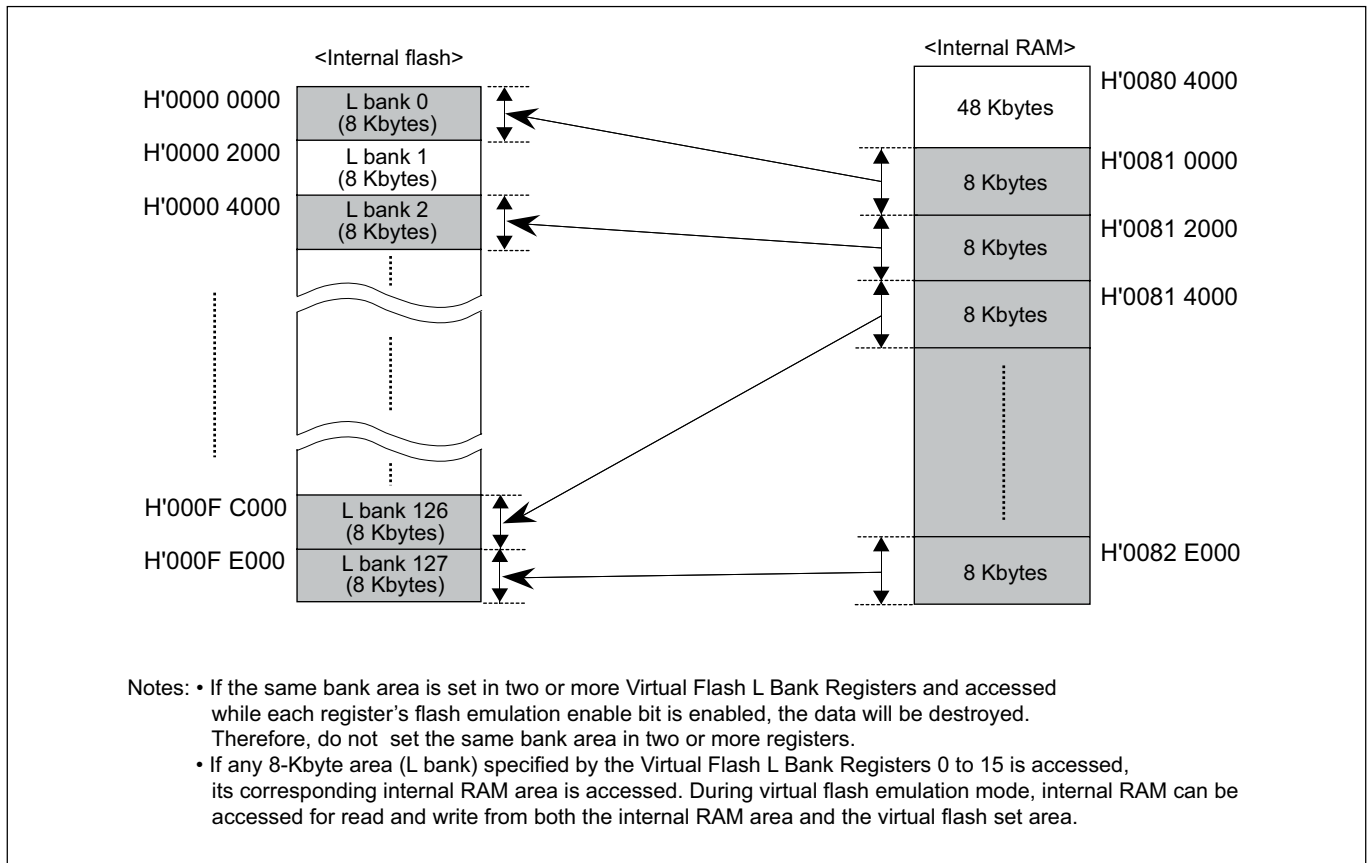


Figure 6.7.4 Virtual Flash Emulation Area divided in 8-Kbyte units for the M32192F8

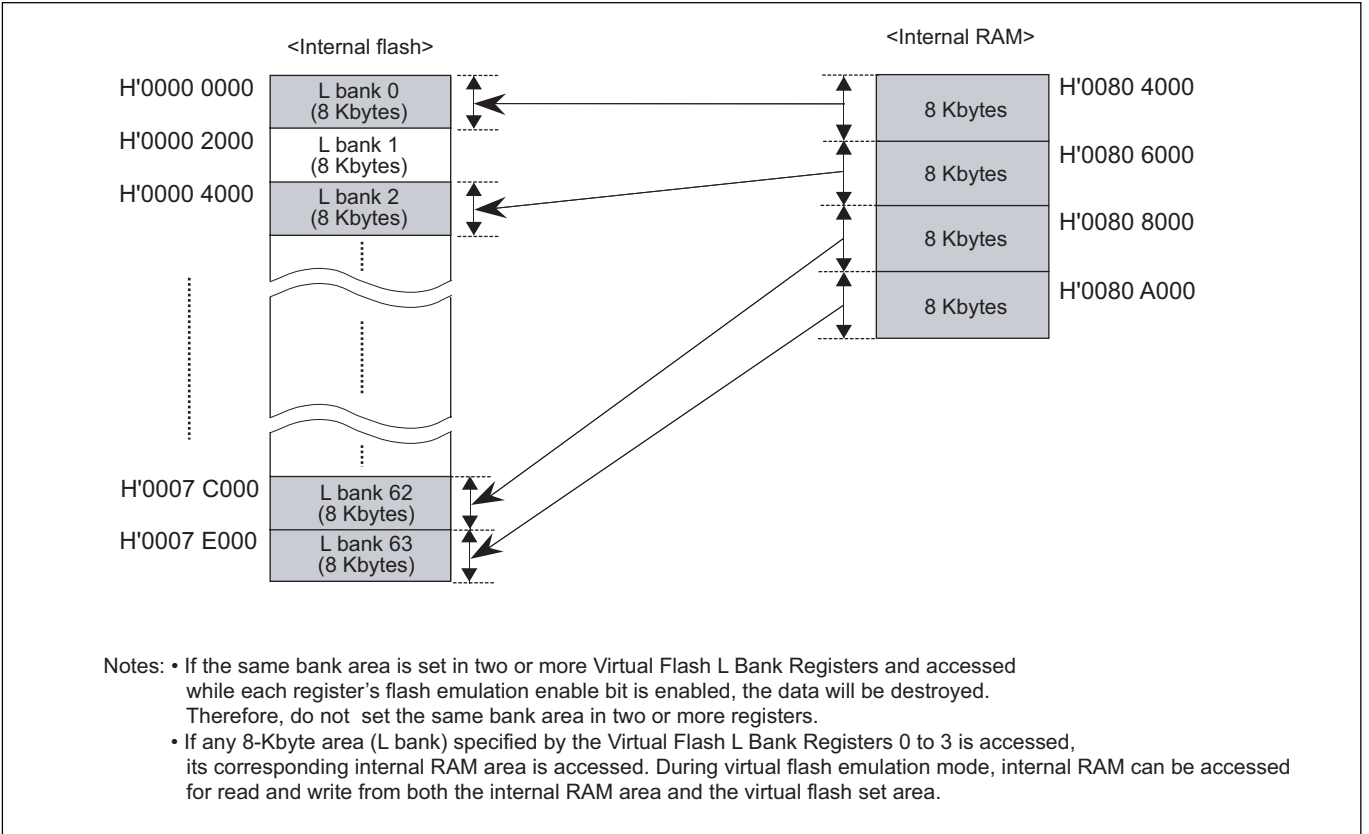


Figure 6.7.5 Virtual Flash Emulation Area divided in 8-Kbyte units for M32195F4

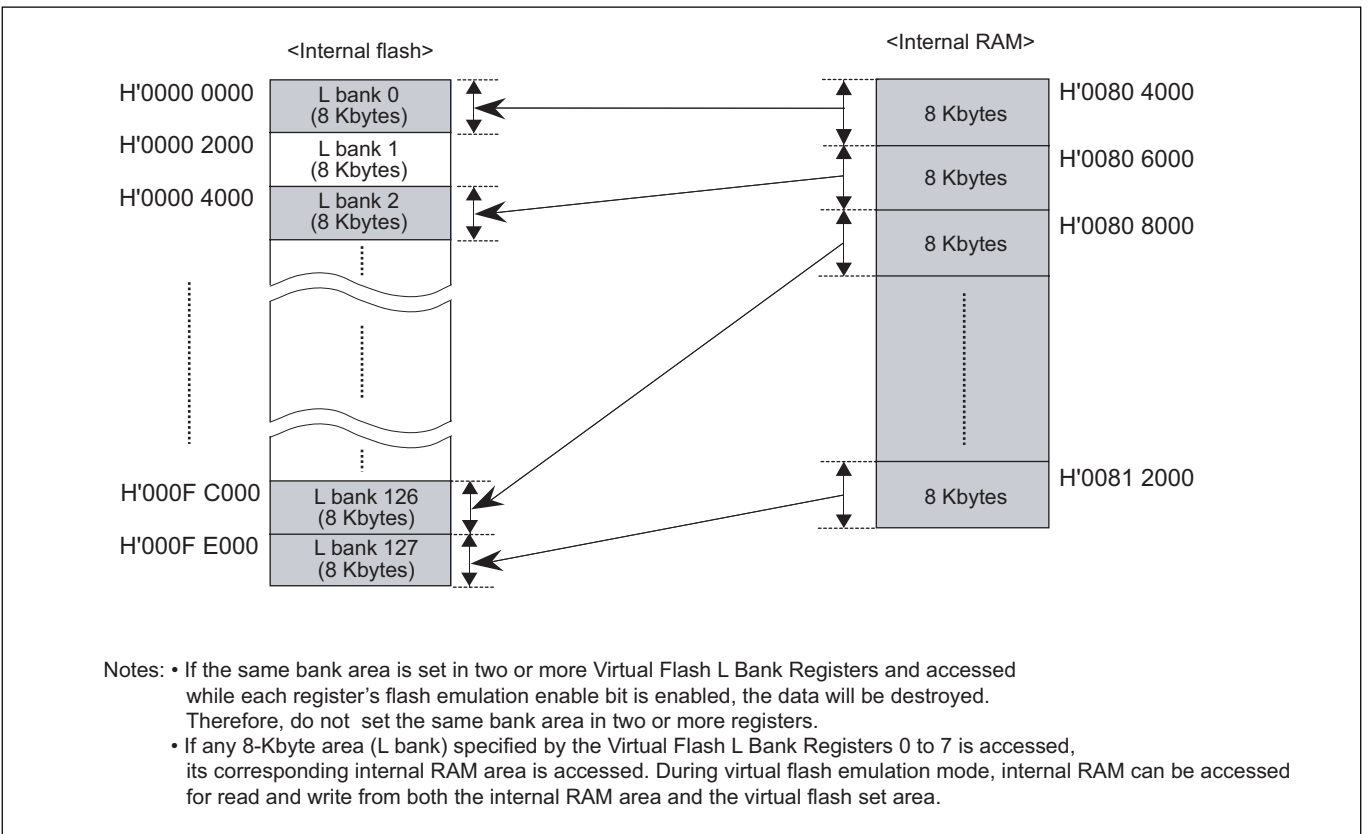


Figure 6.7.6 Virtual Flash Emulation Area divided in 8-Kbyte units for M32196F8

L bank	Start address of bank in flash memory	Values set in L bank address (LBANKAD) bit
L bank 0	H'0000 0000 (Note 1)	H'000
L bank 1	H'0000 2000 (Note 1)	H'002
L bank 2	H'0000 4000 (Note 1)	H'004
⋮		
L bank 126	H'000F C000 (Note 1)	H'0FC
L bank 127	H'000F E000 (Note 1)	H'0FE

Note 1: Set the eight start address bits A11-A18 of each L bank of internal flash memory that is divided in 8-Kbyte units in the Virtual Flash L Bank Register's L bank address (LBANKAD) bits.  
Note: • Because the internal flash memory of the M32192F8 and M32196F8 are 1M (1024K) bytes, the address b7 (A11) must always be set to "0."

**Figure 6.7.7 Values Set in Virtual Flash Bank Register when divided in 8-Kbyte units (32192/32196)**

L bank	Start address of bank in flash memory	Values set in L bank address (LBANKAD) bit
L bank 0	H'0000 0000 (Note 1)	H'000
L bank 1	H'0000 2000 (Note 1)	H'002
L bank 2	H'0000 4000 (Note 1)	H'004
⋮		
L bank 62	H'0007 C000 (Note 1)	H'07C
L bank 63	H'0007 E000 (Note 1)	H'07E

Note 1: Set the eight start address bits A11-A18 of each L bank of internal flash memory that is divided in 8-Kbyte units in the Virtual Flash L Bank Register's L bank address (LBANKAD) bits.  
Note: • Because the internal flash memory of the M32195F4 is 512 Kbytes, the address b7 (A11) and b8 (A12) must always be set to "0."

**Figure 6.7.8 Values Set in Virtual Flash Bank Register when divided in 8-Kbyte units (32195)**

### 6.7.2 Entering Virtual Flash Emulation Mode

To enter virtual flash emulation mode, set the Flash Control Register 1 (FCNT1) FEMMOD bit by writing "1." After entering virtual flash emulation mode, set the Virtual Flash L Bank Register MODENL bit to "1" to enable the Virtual Flash Emulation Function.

Even during virtual flash emulation mode, the internal RAM area ( M32192F8 : H'0080 4000 to H'0082 FFFF, M32195F4 : H'0080 4000 to H'0080 BFFF, M32196F8 : H'0080 4000 to H'0081 3FFF ) can be accessed the same way as in usual internal RAM.

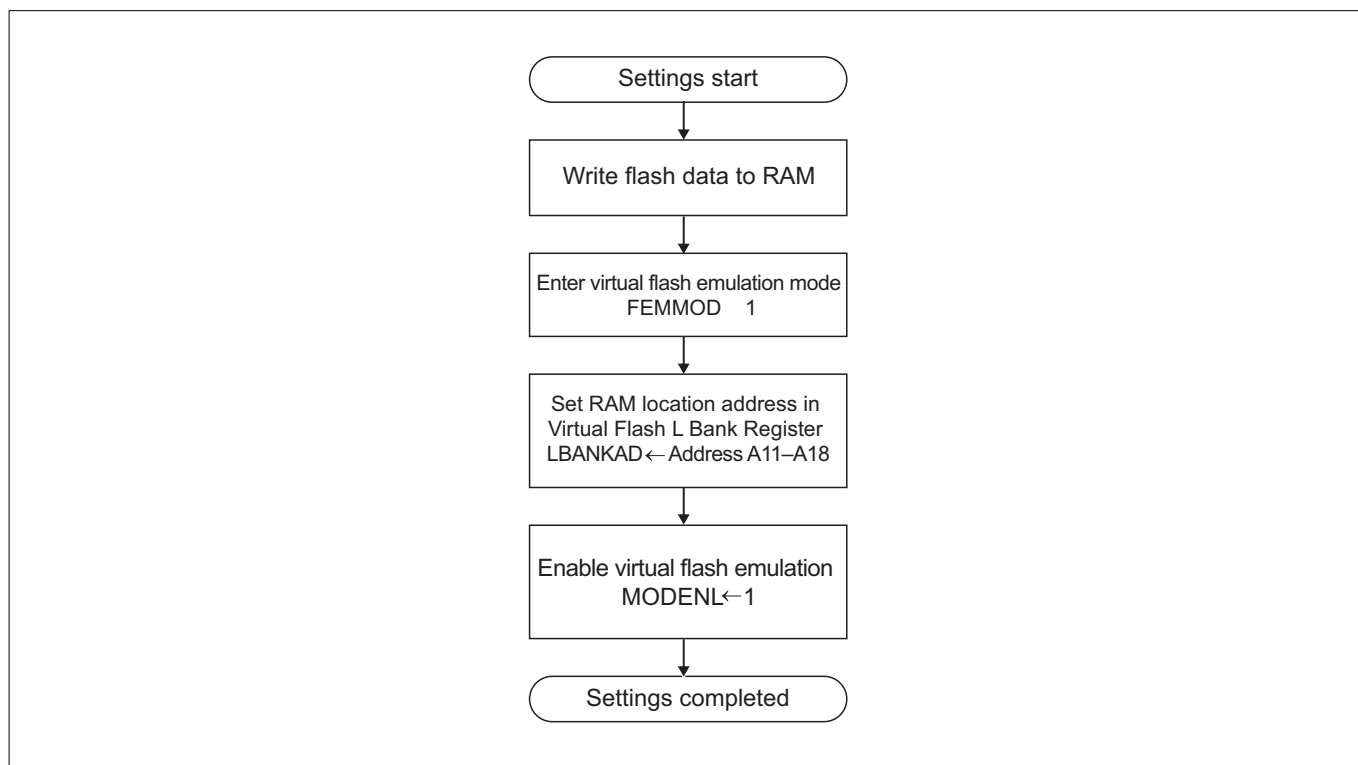


Figure 6.7.9 Virtual Flash Emulation Mode Sequence

## 6.8 Connecting to A Serial Programmer (CSIO Mode)

For the internal flash memory to be rewritten in boot mode + flash E/W enable mode by using a general-purpose serial programmer, several pins on the microcomputer must be processed to make them suitable for the serial programmer, as shown below.

**Table 6.8.1 Processing Microcomputer Pins before Using a Serial Programmer (CSIO Mode)**

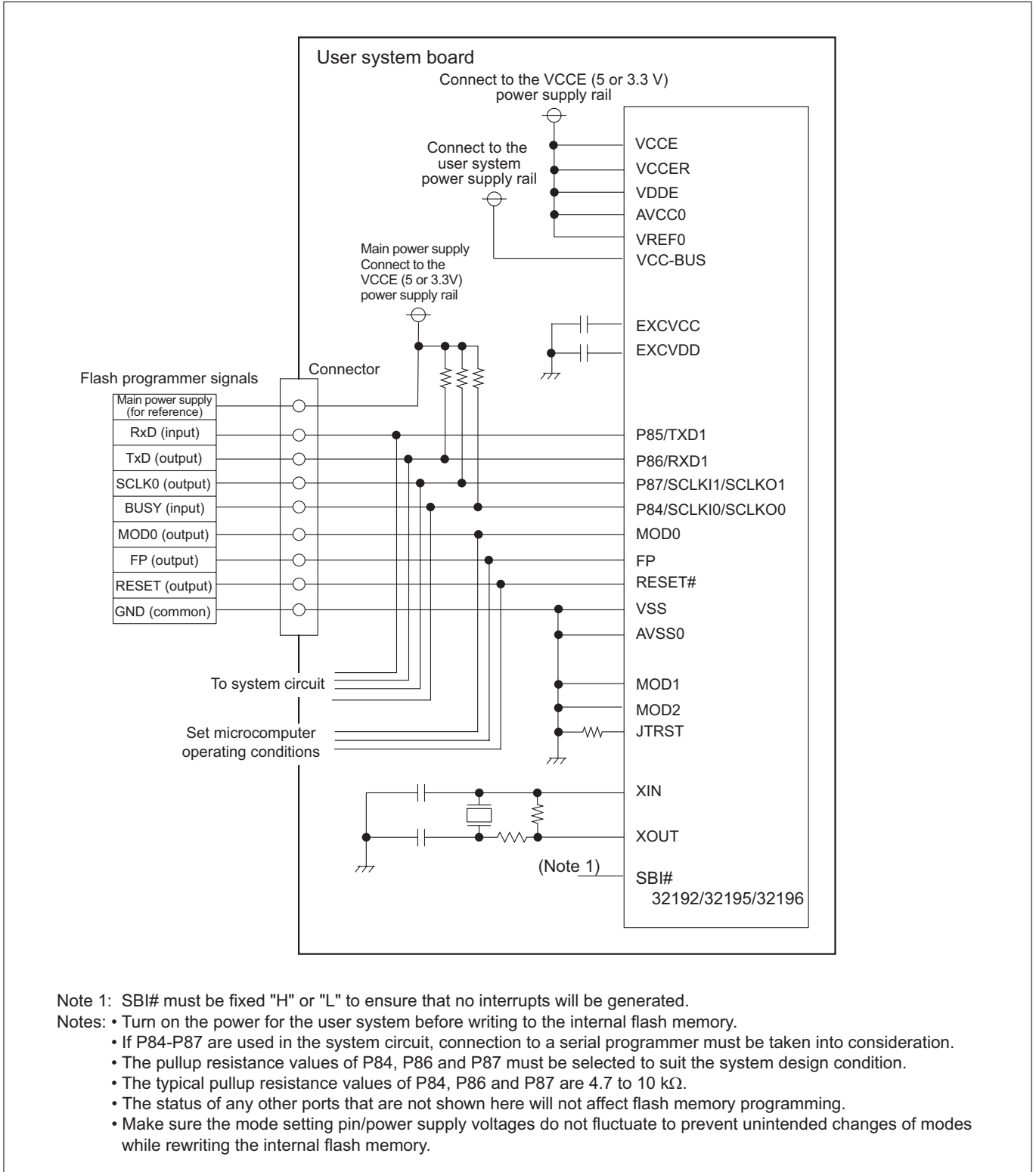
Pin Name	Pin No.	Function	Remark
SCLKI1	71	Transfer clock input	Pull high
RXD1	70	Serial data input (received data)	Pull high
TXD1	69	Serial data output (transmit data)	
P84	68	Transmit/receive enable output	Pull high
FP	94	Flash memory protect	Pull high
MOD0	92	Operation mode 0	Connect to the main power supply
MOD1	93	Operation mode 1	Connect to ground
MOD2	123	Operation mode 2	Connect to ground
RESET#	91	Reset	After setting MOD0/MOD1, ground and back to main power supply
XIN	4	Clock input	
XOUT	5	Clock output	
SBI#	77	System Break Interrupt (SBI) input	Pull high or low
VREF0	42	Reference voltage input for A/D converter	Connect to the main power supply
AVCC0	43	Analog power supply	Connect to the main power supply
AVSS0	60	Analog ground	Connect to ground
VDDE	108	RAM backup power supply	Connect to the main power supply
VCCER	65	Power supply for the internal voltage generator circuit	5 V +/- 10% or 3.3 V +/- 10%
VCCE	95, 132	Main power supply	5 V +/- 10% or 3.3 V +/- 10%
EXCVCC	61, 137	Connects external capacitance for the internal power supply	Need to be grounded to earth via capacitor
EXCVDD	73	Connects external capacitance for the RAM power supply	Need to be grounded to earth via capacitor
VCC-BUS	6, 20	External bus power supply	Depends on the target system
VSS	3, 21, 62, 72, 96, 138	Ground	0V
JTRST	111	JTAG reset input	Pull low (0 - 100kΩ)

Note: • Pin processing is not required for those that are not listed above.



## 6.8 Connecting to A Serial Programmer (CSIO Mode)

The diagram below shows an example of a user system configuration which has had a serial programmer connected. After the user system is powered on, the serial programmer writes to the internal flash memory in clock-synchronous serial mode (CSIO mode). No communication problems associated with the oscillator frequency may occur. If the system uses any pins that are to be connected to a serial programmer, care must be taken to prevent adverse effects on the system when a serial programmer is connected. Note that the serial programmer uses the addresses H'0000 0084 through H'0000 008F as an area in which to check the ID for flash memory protection. If the internal flash memory needs to be protected, set any ID in this area.



Note 1: SBI# must be fixed "H" or "L" to ensure that no interrupts will be generated.

Notes: • Turn on the power for the user system before writing to the internal flash memory.

- If P84-P87 are used in the system circuit, connection to a serial programmer must be taken into consideration.
- The pullup resistance values of P84, P86 and P87 must be selected to suit the system design condition.
- The typical pullup resistance values of P84, P86 and P87 are 4.7 to 10 kΩ.
- The status of any other ports that are not shown here will not affect flash memory programming.
- Make sure the mode setting pin/power supply voltages do not fluctuate to prevent unintended changes of modes while rewriting the internal flash memory.

Figure 6.8.1 Pin Connection Diagram (CSIO Mode)

## 6.9 Connecting to A Serial Programmer (UART Mode)

For the internal flash memory to be rewritten in boot mode + flash E/W enable mode by using a general-purpose serial programmer, several pins on the microcomputer must be processed to make them suitable for the serial programmer, as shown below.

**Table 6.9.1 Processing Microcomputer Pins before Using a Serial Programmer (UART Mode)**

Pin Name	Pin No.	Function	Remark
SCLKI1	71	SIO mode selection	Pull low ("L" level input)
RXD1	70	Serial data input (received data)	Pull high
TXD1	69	Serial data output (transmit data)	
P84	68	General-purpose port input	Not used during UART mode Pull high or pull low
FP	94	Flash memory protect	Pull high
MOD0	92	Operation mode 0	Connect to the main power supply
MOD1	93	Operation mode 1	Connect to ground
MOD2	123	Operation mode 2	Connect to ground
RESET#	91	Reset	
XIN	4	Clock input	
XOUT	5	Clock output	
SBI#	77	System Break Interrupt (SBI) input	Pull high or low
VREF0	42	Reference voltage input for A/D converter	Connect to the main power supply
AVCC0	43	Analog power supply	Connect to the main power supply
AVSS0	60	Analog ground	Connect to ground
VDDE	108	RAM backup power supply	Connect to the main power supply
VCCER	65	Power supply for the internal voltage generator circuit	5 V +/- 10% or 3.3 V +/- 10%
VCCE	95, 132	Main power supply	5 V +/- 10% or 3.3 V +/- 10%
EXCVCC	61, 137	Connects external capacitance for the internal power supply	Need to be grounded to earth via capacitor
EXCVDD	73	Connects external capacitance for the RAM power supply	Need to be grounded to earth via capacitor
VCC-BUS	6, 20	External bus power supply	Depends on the target system
VSS	3, 21, 62, 72, 96, 138	Ground	0V
JTRST	111	JTAG reset input	Pull low (0 - 100k $\Omega$ )

Note: • Pin processing is not required for those that are not listed above.

## 6.9 Connecting to A Serial Programmer (UART Mode)

The diagram below shows an example of a user system configuration which has had a serial programmer connected. After the user system is powered on, the serial programmer writes to the internal flash memory in clock-asynchronous serial mode (UART mode). No communication problems associated with the oscillator frequency may occur. If the system uses any pins that are to be connected to a serial programmer, care must be taken to prevent adverse effects on the system when a serial programmer is connected. Note that the serial programmer uses the addresses H'0000 0084 through H'0000 008F as an area in which to check the ID for flash memory protection. If the internal flash memory needs to be protected, set any ID in this area.

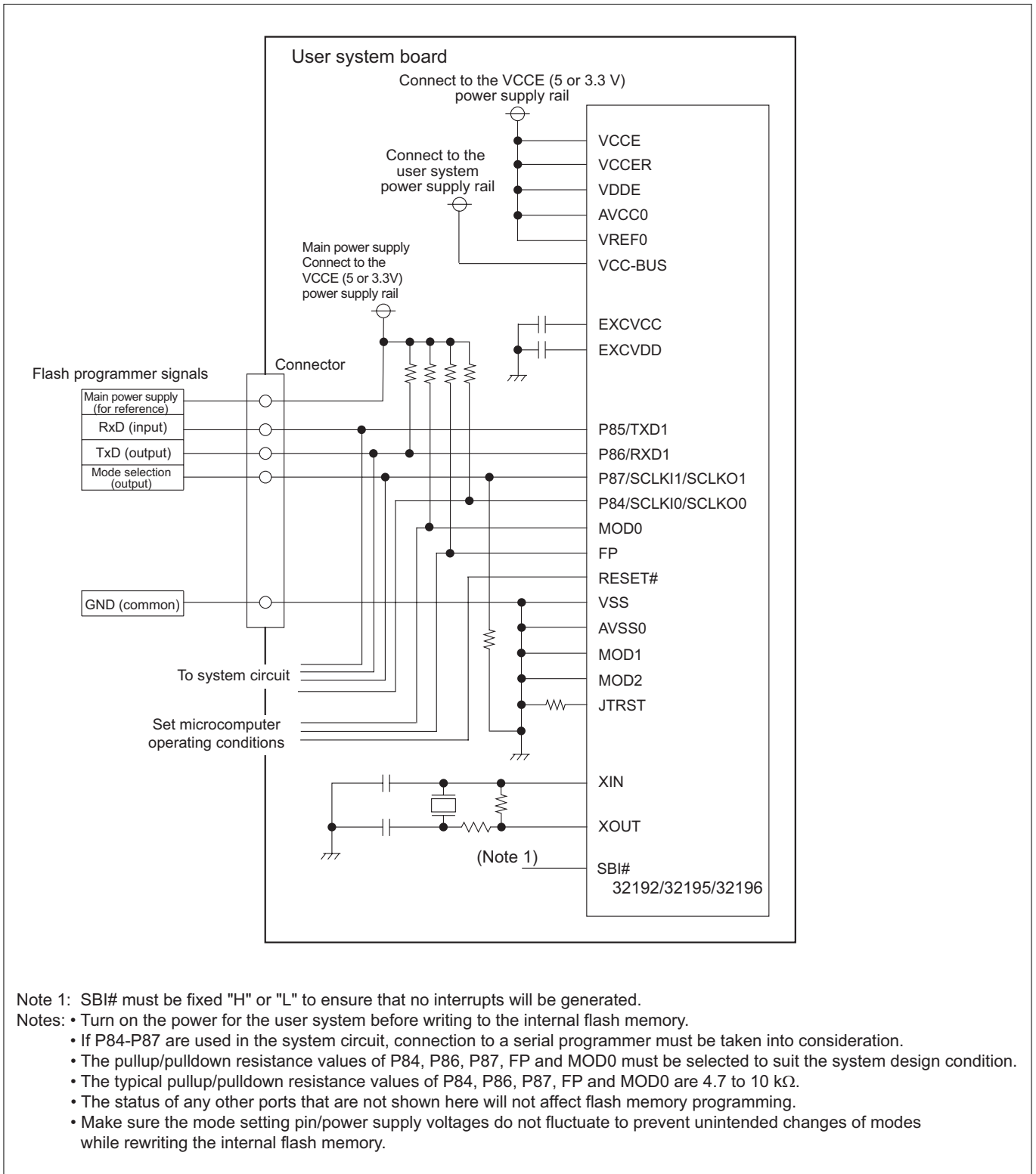


Figure 6.9.1 Pin Connection Diagram (UART Mode)

## 6.10 Internal Flash Memory Protect Function

The internal flash memory has the following four types of protect functions to prevent it from being inadvertently rewritten or illegally copied, programmed or erased.

### (1) Flash memory protect ID

When using a tool to program/erase the internal flash memory such as a general-purpose programmer or emulator, the ID entered by a tool and the ID stored in the internal flash memory are collated. Unless the correct ID is entered, the internal flash memory cannot be read out, programmed nor erased. (For some tools, tool execution is enabled after erasing the entire flash memory area, and the internal flash memory becomes accessible for write.)

### (2) Protection by FP pin

The internal flash memory is protected in hardware against programming/erase operation by pulling the FP (Flash Protect) pin "L". For systems that do not require rewriting flash memory or systems in which flash reprogramming is prohibited as in the case of automotive applications, make sure the FP pin is fixed "L" except when programming or erasing the internal flash memory. Furthermore, because the FP pin level can be known by reading the Flash Mode Register (FMODE)'s FPMODE (external FP pin status) bit in the flash write/erase program, the internal flash memory can also be protected in software. For systems that do not require protection by setting external pins, the FP pin may be fixed "H" to simplify the operation to program/erase the internal flash memory. However, to prevent the flash memory from being inadvertently rewritten by an erratic operation in software, use the protection by a lock bit described in (4) below.

When programming/erasing via JTAG, the flash memory can be programmed or erased regardless of the pin state because the FP pin is controlled internally within the chip.

### (3) Protection by FENTRY bit

Flash E/W enable mode cannot be entered into unless the Flash Control Register 1 (FCNT1)'s FENTRY (flash mode entry) bit is set to "1." To set the FENTRY bit to "1," write "0" and then "1" in succession while the FP pin is "H."

### (4) Protection by a lock bit

Any block of internal flash memory can be protected by setting the lock bit provided for it to "0." That memory block is disabled against programming/erase operation.

## 6.11 Notes on the Internal RAM

Precautions about the Internal Memory is shown below.

- The writes from DRI,RTD to internal RAM uncomplete with access from other bus masters (CPU, DMA, NBD, SDI), because of using dedicated bus not M32R-FPU.  
But in case DRI,RTD transfers and access from other bus masters for area in 16-Kbyte of internal RAM occur at same time, access competition occurs.  
When access competition occurs, arbitration is performed according to the following priority.

NBD/SDI > DMA > CPU > DRI > RTD

- When started by boot mode, internal RAM value is indefinite after started by boot mode in order to "Flash writing/erasing program" is transferred to internal RAM.

## 6.12 Notes on the Internal Flash Memory

The following describes precautions to be taken when programming/erasing the internal flash memory.

- When the internal flash memory is programmed or erased, a high voltage is generated internally. Because mode transitions during programming/erase operation may cause the chip to break down, make sure the mode setting/reset pin and power supply voltages do not fluctuate to prevent unintended changes of modes.
- If the system uses any pins that are to be used by a general-purpose programming/erase tool, care must be taken to prevent adverse effects on the system when the tool is connected.
- If the internal flash memory needs to be protected while using a general-purpose programming/erase tool, set any ID in the flash memory protect ID verification area (H'0000 0084 to H'0000 008F).
- If the internal flash memory does not need to be protected while using a general-purpose programming/erase tool, fill the entire flash memory protect ID verification area (H'0000 0084 to H'0000 008F) with H'FF.
- If the Flash Status Register (FSTAT)'s each error status is to be cleared (initialized to H'80) by resetting the Flash Control Register 4 (FCNT4) FRESET bit, check to see that the Flash Status Register (FSTAT) FBUSY bit = "1" (ready) before clearing the error status.
- Before resetting the Flash Control Register 1 (FCNT1) FENTRY bit from "1" to "0," check to see that the Flash Status Register (FSTAT) FBUSY bit = "1" (ready).
- Do not clear the FENTRY bit if the Flash Control Register 1 (FCNT1) FENTRY bit = "1" and the Flash Status Register (FSTAT) FBUSY bit = "0" (being programmed or erased).
- When programming/erasing via JTAG, the flash memory can be programmed or erased regardless of the pin state because the FP pin is controlled internally within the chip.

This page is blank for reasons of layout.

# CHAPTER 7

---

## RESET

- 7.1 Outline of Reset
- 7.2 Reset Operation
- 7.3 Internal State upon Exiting Reset
- 7.4 Things to Be Considered upon Exiting Reset

## 7.1 Outline of Reset

The microcomputer is reset by applying a "L" level signal to the RESET# input pin. The microcomputer is gotten out of a reset state by releasing the RESET# input back high, upon which the reset vector entry address is set in the Program Counter (PC) and the CPU starts executing from the reset vector entry.

## 7.2 Reset Operation

When a "L" level signal in width of more than 300 ns is applied to the RESET# pin, the microcomputer enters a reset state. At this time, the internal circuits (including the CPU) are reset. (For details about the pin state when reset, see Table 1.4.1, "Pin Assignments of the M32192F8xFP, M32195F4xFP, and M32196F8xFP" and Table 1.4.2 "Pin Assignments of the M32192F8xWG")

When the RESET# input is returned "H," the internal circuits get out of a reset state (2333 to 2334 BCLK) periods after that.

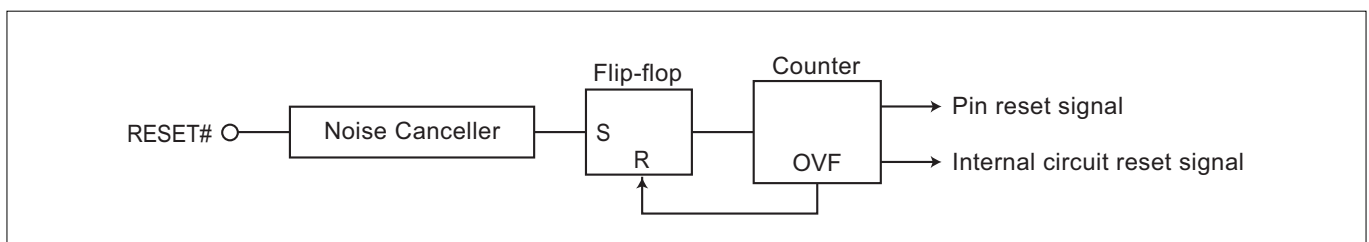


Figure 7.2.1 Reset Circuit

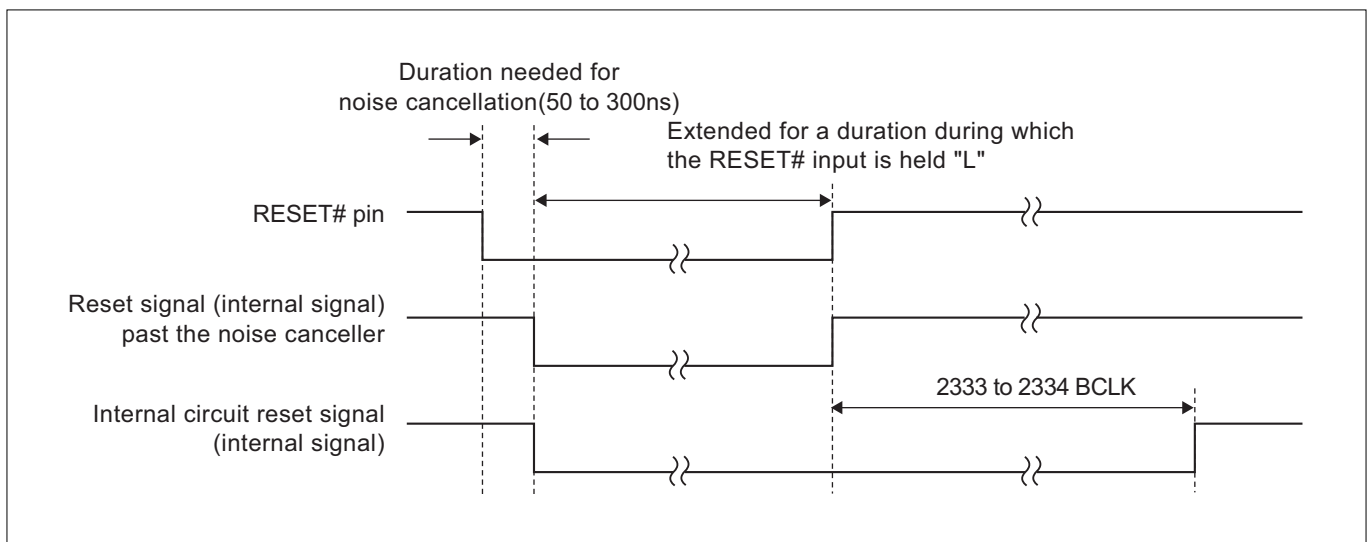


Figure 7.2.2 Reset Sequence



### 7.2.1 Reset at Power-on

When powering on the microcomputer, hold the RESET# signal input pin "L" until the rated power supply voltage is reached and the microcomputer's internal x8 clock generator becomes oscillating stably. For details, see Section 22.2, "Power-On Sequence."

### 7.2.2 Reset during Operation

To reset the microcomputer during operation, hold the RESET# signal input pin "L" for more than 300 ns.

### 7.2.3 Reset Vector Relocation during Flash Programming

When the microcomputer is reset after entering boot mode, the reset vector entry address is moved to the boot program startup address. The boot program starts running after the reset state is deasserted. For details, see Section 6.6, "Programming the Internal Flash Memory."

### 7.3 Internal State upon Exiting Reset

The table below lists the internal state of the microcomputer when it has gotten out of a reset state. For details about the initial register state of each internal peripheral I/O, see each section in this manual in which the relevant internal peripheral I/O is described.

**Table 7.3.1 Internal State upon Exiting Reset**

Register	State upon exiting reset
PSW (CR0)	B'0000 0000 0000 0000 ??00 000? 0000 0000 (BSM, BIE, BC bits = undefined)
CBR (CR1)	H'0000 0000 (C bits = 0)
SPI (CR2)	Undefined
SPU (CR3)	Undefined
BPC (CR6)	Undefined
FPSR (CR7)	H'0000 0100 (only DN bit = 1)
PC	H'0000 0000 (Executed beginning with the address H'0000 0000) (Note 1)
R0–R15	Undefined
ACC (accumulator)	Undefined
RAM	Undefined when reset at power-on. (However, if the RAM is gotten out of reset after returning from backup mode, it retains the content it had before being reset.)

Note 1: When in boot mode, the CPU executes the boot program.

### 7.4 Things to Be Considered upon Exiting Reset

- **Input/output ports**

When exiting reset, the microcomputer's input/output ports are disabled against input in order to prevent shoot-through current. To use any ports in input mode, set the Port Input Special Function Control Register (PICNT) PIEN0 bit to enable them for input. For details, see Section 8.3, "Input/Output Port Related Registers."

## **CHAPTER 8**

---

# **INPUT/OUTPUT PORTS AND PIN FUNCTIONS**

- 8.1 Outline of Input/Output Ports
- 8.2 Selecting Pin Functions
- 8.3 Input/Output Port Related Registers
- 8.4 Port Input Level Switching Function
- 8.5 Port Output Drive Capability Setting Function
- 8.6 Noise Canceller Control Function
- 8.7 Port Peripheral Circuits
- 8.8 Notes on Input/Output Ports

## 8.1 Outline of Input/Output Ports

The 32192/32195/32196 has a total of 97 input/output ports from P0–P13, P15, P17 and P22 (except P5, which is reserved for future use). These input/output ports can be used as input or output ports by setting the respective direction registers.

Each input/output port has double or triple functions shared with other internal peripheral I/O or external bus interface related signal lines, or multiple functions shared with multi-function peripheral I/Os. Pin functions are selected depending on the operation mode of the CPU or by setting the operation mode register and peripheral function select register for the input/output port. (If any internal peripheral I/O has still another function, it is also necessary to set the register provided for that internal peripheral I/O.)

Abundant port functions are incorporated, including a port input level switching function, port output drive capability setting function, and noise canceller control function.

Note that before any ports can be used in input mode, this port input function enable bit must be set accordingly.

The input/output ports are outlined below.

**Table 8.1.1 Outline of Input/Output Ports**

Item	Specification
Number of ports	Total 97 ports
	P0 : P00–P07 (8 ports)
	P1 : P10–P17 (8 ports)
	P2 : P20–P27 (8 ports)
	P3 : P30–P37 (8 ports)
	P4 : P41–P47 (7 ports)
	P6 : P61–P63 (3 ports)
	P7 : P70–P77 (8 ports)
	P8 : P82–P87 (6 ports)
	P9 : P93–P97 (5 ports)
	P10 : P100–P107 (8 ports)
	P11 : P110–P117 (8 ports)
	P12 : P124–P127 (4 ports)
	P13 : P130–P137 (8 ports)
	P15 : P150, P153 (2 ports)
	P17 : P174, P175 (2 ports)
	P22 : P220, P221, P224, P225 (4 ports)
Port function	The input/output ports can individually be set for input or output mode using the direction control register provided for each input/output port. (However, P221 is an input-only port.)
Pin function	Shared with peripheral I/O or external bus interface signals to serve dual-functions (or shared with two or more peripheral I/O functions to serve multiple functions)

Note: • P5, P14, P16, P18-P21 are nonexistent.

## 8.2 Selecting Pin Functions

Each input/output port has double or triple functions shared with other internal peripheral I/O or external bus interface related signal lines, or multiple functions shared with multi-function peripheral I/Os. Pin functions are selected depending on the operation mode of the CPU or by setting the operation mode register and peripheral function select register for the input/output port. (If any internal peripheral I/O has still another function, it is also necessary to set the register provided for that internal peripheral I/O.)

P0–P4, P124, P125, P224 and P225, when the CPU is set to operate in processor mode, all are switched to serve as signal pins for external access. The CPU operation mode is determined depending on how the MOD0 and MOD1 pins are set (see the table below).

**Table 8.2.1 CPU Operation Modes and P0–P4, P124, P125, P224 and P225 Pin Functions**

MOD0	MOD1	Operation Mode	P0–P4, P124, P125, P224 and P225 Pin Function
VSS	VSS	Single-chip mode	Input/output port pin
VSS	VCCE	External extension mode	Input/output port or external bus interface signal pin (Note 1)
VCCE	VSS	Processor mode	External bus interface signal pin
VCCE	VCCE	(Settings inhibited)	–

Note 1: P41–P43 only function as external bus interface signal pins.

Note: • VCCE and VSS are connected to main power supply and GND, respectively.

Each input/output port has their functions switched between input/output port pins and internal peripheral I/O pins by setting the respective port operation mode and peripheral function select registers. If any internal peripheral I/O has two or more pin functions, use the register provided for that internal peripheral I/O to select the desired pin function.

Note that FP pin operations during internal flash memory programming do not affect the pin functions.

Pin functions are selected by the settings for the port operation mode and port peripheral function select registers

Pin functions are selected by the settings for the port operation mode, port peripheral function select and NBD function select registers

	0	1	2	3	4	5	6	7
P0	TO21 / DD0	TO22 / DD1	TO23 / DD2	TO24 / DD3	TO25 / DD4	TO26 / DD5	TO27 / DD6	TO28 / DD7
P1	TO29 / DD8	TO30 / DD9	TO31 / DD10	TO32 / DD11	TO33 / DD12	TO34 / DD13	TO35 / DD14	TO36 / DD15
P2	DD24	DD25	DD26	DD27	DD28	DD29	DD30	DD31
P3	TIN4 / DD16	TIN5 / DD17	TIN6 / DD18	TIN7 / DD19	TIN30 / DD20	TIN31 / DD21	TIN32 / DD22	TIN33 / DD23
P4		P41 (Port only)	P42 (Port only)	P43 (Port only)	TIN8	TIN9	TIN10	TIN11
P5								
P6		P61 (Port only)	P62 (Port only)	P63 (Port only)	SBI# (Note 1)			
P7	CLKOUT / WR# / BCLK(Note 2)	WAIT#	HREQ# / TIN27	HACK# / TIN26	RTDTRXD / TXD3 / NBDD0	RTDRXD / RXD3 / NBDD1	RTDACK / CTX1 / NBDD2	RTDCLK / CRX1 / NBDD3
P8	MOD0 (Note 1)	MOD1 (Note 1)	TXD0 / TO26	RXD0 / TO25	SCLK0 / SCLKO0 / TO24	TXD1 / TO23	RXD1 / TO22	SCLK1 / SCLKO1 / TO21
P9				TO16 / SCLK15 / SCLKO5	TO17 / TXD5 / DD15	TO18 / RXD5 / DD14	TO19 / DD13	TO20 / DD12
P10	TO8	TO9 / CRX0	TO10 / CTX0	TO11 / TIN24	TO12 / TIN25 / DD3	TO13 / SCLK14 / SCLKO4 / DD2	TO14 / TXD4 / DD1	TO15 / RXD4 / DD0
P11	TO0 / TO29 / DD11	TO1 / TO30 / DD10	TO2 / TO31 / DD9	TO3 / TO32 / DD8	TO4 / TO33 / DD7	TO5 / TO34 / DD6	TO6 / TO35 / DD5	TO7 / TO36 / DD4
P12					TCLK0 / DD3	TCLK1 / DD2	TCLK2 / DD1	TCLK3 / DD0
P13	TIN16 / PWMOFF0 / DIN0	TIN17 / PWMOFF1 / DIN1	TIN18 / DIN2	TIN19 / DIN3	TIN20 / TXD3 / DIN4	TIN21 / RXD3	TIN22 / CRX1	TIN23 / CTX1
P14								
P15	TIN0 / CLKOUT / WR#(Note 2)			TIN3 / WAIT#				
P16								
P17					TXD2 / TO28	RXD2 / TO27		
P18								
P19								
P20								
P21								
P22	CTX0 / HACK#	CRX0 / HREQ#			P224 (Port only)	P225 (Port only)		

Note 1: These ports cannot be used for input/output port function. The SBI#, MOD0 and MOD1 pin input levels can be read from these ports.

Note 2: Respective functions are selected by the Bus Mode Control Register.

Notes: • P5, P14, P16, P18, P19, P20 and P21 are not provided.

• Some functions have two separate pins assigned per function. For details, see Table 8.2.2.

Figure 8.2.1 Input/Output Ports and Pin Function Assignments during Single Chip Mode

Pin functions are selected by the settings for the port operation mode and port peripheral function select registers

Pin functions are selected by the settings for the port operation mode, port peripheral function select and NBD function select registers

	0	1	2	3	4	5	6	7
P0	DB0 / TO21 / DD0	DB1 / TO22 / DD1	DB2 / TO23 / DD2	DB3 / TO24 / DD3	DB4 / TO25 / DD4	DB5 / TO26 / DD5	DB6 / TO27 / DD6	DB7 / TO28 / DD7
P1	DB8 / TO29 / DD8	DB9 / TO30 / DD9	DB10 / TO31 / DD10	DB11 / TO32 / DD11	DB12 / TO33 / DD12	DB13 / TO34 / DD13	DB14 / TO35 / DD14	DB15 / TO36 / DD15
P2	A23 / DD24	A24 / DD25	A25 / DD26	A26 / DD27	A27 / DD28	A28 / DD29	A29 / DD30	A30 / DD31
P3	A15 / TIN4 / DD16	A16 / TIN5 / DD17	A17 / TIN6 / DD18	A18 / TIN7 / DD19	A19 / TIN30 / DD20	A20 / TIN31 / DD21	A21 / TIN32 / DD22	A22 / TIN33 / DD23
P4		BLW# / BLE# (Note 1, 3)	BHW# / BHE# (Note 1, 3)	RD# (Note 1)	CS0# / TIN8	CS1# / TIN9	A13 / TIN10	A14 / TIN11
P5								
P6		P61 (Port only)	P62 (Port only)	P63 (Port only)	SBI# (Note 2)			
P7	CLKOUT / WR# / BCLK (Note 3)	WAIT#	HREQ# / TIN27	HACK# / TIN26	RTDTRXD / TXD3 / NBDD0	RTDRXD / RXD3 / NBDD1	RTDACK / CTX1 / NBDD2	RTDCLK / CRX1 / NBDD3
P8	MOD0 (Note 2)	MOD1 (Note 2)	TXD0 / TO26	RXD0 / TO25	SCLK10 / SCLK0 / TO24	TXD1 / TO23	RXD1 / TO22	SCLK11 / SCLK01 / TO21
P9				TO16 / SCLK15 / SCLK05	TO17 / TXD5 / DD15	TO18 / RXD5 / DD14	TO19 / DD13	TO20 / DD12
P10	TO8	TO9 / CRX0	TO10 / CTX0	TO11 / TIN24	TO12 / TIN25 / DD3	TO13 / SCLK14 / SCLK04 / DD2	TO14 / TXD4 / DD1	TO15 / RXD4 / DD0
P11	TO0 / TO29 / DD11	TO1 / TO30 / DD10	TO2 / TO31 / DD9	TO3 / TO32 / DD8	TO4 / TO33 / DD7	TO5 / TO34 / DD6	TO6 / TO35 / DD5	TO7 / TO36 / DD4
P12					TCLK0 / A9 / DD3	TCLK1 / A10 / DD2	TCLK2 / CS2# / DD1	TCLK3 / CS3# / DD0
P13	TIN16 / PWMOFF0 / DIN0	TIN17 / PWMOFF1 / DIN1	TIN18 / DIN2	TIN19 / DIN3	TIN20 / TXD3 / DIN4	TIN21 / RXD3	TIN22 / CRX1	TIN23 / CTX1
P14								
P15	TIN0 / CLKOUT / WR# (Note 3)			TIN3 / WAIT#				
P16								
P17					TXD2 / TO28	RXD2 / TO27		
P18								
P19								
P20								
P21								
P22	CTX0 / HACK#	CRX0 / HREQ#			A11 / CS2#	A12 / CS3#		

Note 1: These ports cannot be used for input/output port function, function as external bus interface related signals.

Note 2: These ports cannot be used for input/output port function. The SBI#, MOD0 and MOD1 pin input levels can be read from these ports.

Note 3: Respective functions are selected by the Bus Mode Control Register.

Notes: • P5, P14, P16, P18, P19, P20 and P21 are not provided.

• Some functions have two separate pins for function. For details, see Table 8.2.2.

Figure 8.2.2 Input/Output Ports and Pin Function Assignments during External Extension Mode

		0	1	2	3	4	5	6	7
(Note 1)	P0	DB0	DB1	DB2	DB3	DB4	DB5	DB6	DB7
	P1	DB8	DB9	DB10	DB11	DB12	DB13	DB14	DB15
	P2	A23	A24	A25	A26	A27	A28	A29	A30
	P3	A15	A16	A17	A18	A19	A20	A21	A22
	P4		BLW# / BLE#(Note 3)	BHW# / BHE#(Note 3)	RD#	CS0#	CS1#	A13	A14
	P5								
	P6		P61 (Port only)	P62 (Port only)	P63 (Port only)	SBI# (Note 2)			
	P7	CLKOUT / WR# / BCLK(Note 3)	WAIT#	HREQ# / TIN27	HACK# / TIN26	RTDXTD / TXD3 / NBDD0	RTDRXD / RXD3 / NBDD1	RTDACK / CTX1 / NBDD2	RTDCLK / CRX1 / NBDD3
	P8	MOD0 (Note 2)	MOD1 (Note 2)	TXD0 / TO26	RXD0 / TO25	SCLK10 / SCLK00 / TO24	TXD1 / TO23	RXD1 / TO22	SCLK11 / SCLK01 / TO21
	P9				TO16 / SCLK15 / SCLK05	TO17 / TXD5 / DD15	TO18 / RXD5 / DD14	TO19 / DD13	TO20 / DD12
	P10	TO8	TO9 / CRX0	TO10 / CTX0	TO11 / TIN24	TO12 / TIN25 / DD3	TO13 / SCLK14 / SCLK04 DD2	TO14 / TXD4 / DD1	TO15 / RXD4 / DD0
	P11	TO0 / TO29 / DD11	TO1 / TO30 / DD10	TO2 / TO31 / DD9	TO3 / TO32 / DD8	TO4 / TO33 / DD7	TO5 / TO34 / DD6	TO6 / TO35 / DD5	TO7 / TO36 / DD4
	P12					A9 (Note 1)	A10 (Note 1)	TCLK2 / CS2# / DD1	TCLK3 / CS3# / DD0
	P13	TIN16 / PWMOFF0 / DIN0	TIN17 / PWMOFF1 / DIN1	TIN18 / DIN2	TIN19 / DIN3	TIN20 / TXD3 / DIN4	TIN21 / RXD3	TIN22 / CRX1	TIN23 / CTX1
	P14								
	P15	TIN0 / CLKOUT / WR#(Note 3)			TIN3 / WAIT#				
	P16								
	P17					TXD2 / TO28	RXD2 / TO27		
	P18								
	P19								
	P20								
	P21								
	P22	CTX0 / HACK#	CRX0 / HREQ#			A11/CS2# (Note 1)	A12/CS3# (Note 1)		

Pin functions are selected by the settings for the port operation mode, port peripheral function select and NBD function select registers

Note 1: These ports cannot be used for input/output port function, function as external bus interface related signals.  
 Note 2: These ports cannot be used for input/output port function. The SBI#, MOD0 and MOD1 pin input levels can be read from these ports.  
 Note 3: Respective functions are selected by the Bus Mode Control Register.  
 Notes: • P5, P14, P16, P18, P19, P20 and P21 are not provided.  
 • Some functions have two separate pins assigned per function. For details, see Table 8.2.2.

Figure 8.2.3 Input/Output Ports and Pin Function Assignments during Processor Mode



One peripheral I/O can be assigned to two separate pins by setting the CPU operation mode and peripheral function select register.

**Table 8.2.2 Peripheral I/Os Allowed for Input/Output at Two Pins and Pin Assignments (1/2)**

Module	Signal name	Pin group A	Pin group B	Note
DRI	DD0	P127/TCLK3/CS3#/DD0	P00/DB0/TO21/DD0	(Note 1)
		P107/TO15/RXD4/DD0		
	DD1	P126/TCLK2/CS2/DD1	P01/DB1/TO22/DD1	
		P106/TO14/TXD4/DD1		
	DD2	P125/TCLK1/A10/DD2	P02/DB2/TO23/DD2	
		P105/TO13/SCLKI4/SCLKO4/DD2		
	DD3	P124/TCLK0/A9/DD3	P03/DB3/TO24/DD3	
		P104/TO12/TIN25/DD3		
	DD4	P117/TO7/TO36/DD4	P04/DB4/TO25/DD4	
	DD5	P116/TO6/TO35/DD5	P05/DB5/TO26/DD5	
	DD6	P115/TO5/TO34/DD6	P06/DB6/TO27/DD6	
	DD7	P114/TO4/TO33/DD7	P07/DB7/TO28/DD7	
	DD8	P113/TO3/TO32/DD8	P10/DB8/TO29/DD8	
	DD9	P112/TO2/TO31/DD9	P11/DB9/TO30/DD9	
	DD10	P111/TO1/TO30/DD10	P12/DB10/TO31/DD10	
	DD11	P110/TO0/TO29/DD11	P13/DB11/TO32/DD11	
DD12	P97/TO20/DD12	P14/DB12/TO33/DD12		
DD13	P96/TO19/DD13	P15/DB13/TO34/DD13		
DD14	P95/TO18/RXD5/DD14	P16/DB14/TO35/DD14		
DD15	P94/TO17/TXD5/DD15	P17/DB15/TO36/DD15		
TOU	TO21	P87/SCLKI1/SCLKO1/TO21	P00/DB0/TO21/DD0	(Note 2)
	TO22	P86/RXD1/TO22	P01/DB1/TO22/DD1	
	TO23	P85/TXD1/TO23	P02/DB2/TO23/DD2	
	TO24	P84/SCLKI0/SCLKO0/TO24	P03/DB3/TO24/DD3	
	TO25	P83/RXD0/TO25	P04/DB4/TO25/DD4	
	TO26	P82/TXD0/TO26	P05/DB5/TO26/DD5	
	TO27	P175/RXD2/TO27	P06/DB6/TO27/DD6	
	TO28	P174/TXD2/TO28	P07/DB7/TO28/DD7	
	TO29	P110/TO0/TO29/DD11	P10/DB8/TO29/DD8	
	TO30	P111/TO1/TO30/DD10	P11/DB9/TO30/DD9	
	TO31	P112/TO2/TO31/DD9	P12/DB10/TO31/DD10	
	TO32	P113/TO3/TO32/DD8	P13/DB11/TO32/DD11	
	TO33	P114/TO4/TO33/DD7	P14/DB12/TO33/DD12	
	TO34	P115/TO5/TO34/DD6	P15/DB13/TO34/DD13	
	TO35	P116/TO6/TO35/DD5	P16/DB14/TO35/DD14	
	TO36	P117/TO7/TO36/DD4	P17/DB15/TO36/DD15	
SIO	TXD3	P134/TIN20/TXD3/DIN4	P74/RTDXTD/TXD3/NBDD0	(Note 1)
	RXD3	P135/TIN21/RXD3	P75/RTDRXD/RXD3/NBDD1	
CAN	CTX0	P102/TO10/CTX0	P220/CTX0/HACK#	(Note 2)
	CRX0	P101/TO9/CRX0	P221/CRX0/HREQ#	(Note 1)
	CTX1	P137/TIN23/CTX1	P76/RTDACK/CTX1/NBDD2	(Note 2)
	CRX1	P136/TIN22/CRX1	P77/RTDCLK/CRX1/NBDD3	(Note 1)

**Table 8.2.2 Peripheral I/Os Allowed for Input/Output at Two Pins and Pin Assignments (2/2)**

Module	Signal name	Pin group A	Pin group B	Note
(External bus interface related)	CS2#	P126/TCLK2/CS2#/DD1	P224/A11/CS2#	(Note 2)
	CS3#	P127/TCLK3/CS3#/DD0	P225/A12/CS3#	
	CLKOUT	P150/TIN0/CLKOUT/WR#	P70/CLKOUT/WR#/BCLK	
	WR#	P150/TIN0/CLKOUT/WR#	P70/CLKOUT/WR#/BCLK	
	WAIT#	P153/TIN3/WAIT#	P71/WAIT#	(Note 1)
	HACK#	P220/CTX0/HACK#	P73/HACK#/TIN26	(Note 2)
	HREQ#	P221/CRX0/HREQ#	P72/HREQ#/TIN27	(Note 1)

Note 1: If Pin group A and Pin group B have the same internal peripheral input pin set, the setting for Pin group A comes into effect so that input from Pin group A is accepted as input for the relevant internal peripheral I/O. For the 16 high-order DD input bits of the DRI (DD0–DD15), which pins to use can be selected in the DRI related register. (For details, refer to the Chapter 14, "Direct RAM Interface.")

Note 2: If Pin group A and Pin group B have the same internal peripheral input pin set, the signal is output from both pins.

### 8.3 Input/Output Port Related Registers

The tables below show an input/output port related register map.

Input/Output Port Related Register Map (1/3)

Address	+0 address		+1 address		See pages
	b0	b7	b8	b15	
H'0080 0500	Port Group 0,1 Input Level Setting Register (PG01LEV)		Port Group 3 Input Level Setting Register (PG3LEV)		8-33
H'0080 0502	Port Group 4,5 Input Level Setting Register (PG45LEV)		Port Group 6,7 Input Level Setting Register (PG67LEV)		8-33
H'0080 0504	Port Group 8 Input Level Setting Register (PG8LEV)		(Use inhibited area)		8-33
H'0080 0506	(Use inhibited area)				
H'0080 0508	Port Group 0,1 Output Drive Capability Setting Register (PG01DRV)		Port Group 3 Output Drive Capability Setting Register (PG3DRV)		8-35
H'0080 050A	Port Group 4,5 Output Drive Capability Setting Register (PG45DRV)		Port Group 6,7 Output Drive Capability Setting Register (PG67DRV)		8-35
H'0080 050C	Port Group 8 Output Drive Capability Setting Register (PG8DRV)		P70 Output Drive Capability Setting Register (P70DRV)		8-35 8-36
H'0080 050E	(Use inhibited area)				
H'0080 0510	Noise Canceller Control Register (NZNCLCR)				8-38
H'0080 0700	P0 Data Register (P0DATA)		P1 Data Register (P1DATA)		8-12
H'0080 0702	P2 Data Register (P2DATA)		P3 Data Register (P3DATA)		8-12
H'0080 0704	P4 Data Register (P4DATA)		(Use inhibited area)		8-12
H'0080 0706	P6 Data Register (P6DATA)		P7 Data Register (P7DATA)		8-12
H'0080 0708	P8 Data Register (P8DATA)		P9 Data Register (P9DATA)		8-12
H'0080 070A	P10 Data Register (P10DATA)		P11 Data Register (P11DATA)		8-12
H'0080 070C	P12 Data Register (P12DATA)		P13 Data Register (P13DATA)		8-12
H'0080 070E	(Use inhibited area)		P15 Data Register (P15DATA)		8-12
H'0080 0710	(Use inhibited area)		P17 Data Register (P17DATA)		8-12
	(Use inhibited area)				
H'0080 0716	P22 Data Register (P22DATA)		(Use inhibited area)		8-12
	(Use inhibited area)				

## Input/Output Port Related Register Map (2/3)

Address	+0 address		+1 address		See pages
	b0	b7	b8	b15	
H'0080 0720	P0 Direction Register (P0DIR)		P1 Direction Register (P1DIR)		8-13
H'0080 0722	P2 Direction Register (P2DIR)		P3 Direction Register (P3DIR)		8-13
H'0080 0724	P4 Direction Register (P4DIR)		(Use inhibited area)		8-13
H'0080 0726	P6 Direction Register (P6DIR)		P7 Direction Register (P7DIR)		8-13
H'0080 0728	P8 Direction Register (P8DIR)		P9 Direction Register (P9DIR)		8-13
H'0080 072A	P10 Direction Register (P10DIR)		P11 Direction Register (P11DIR)		8-13
H'0080 072C	P12 Direction Register (P12DIR)		P13 Direction Register (P13DIR)		8-13
H'0080 072E	(Use inhibited area)		P15 Direction Register (P15DIR)		8-13
H'0080 0730	(Use inhibited area)		P17 Direction Register (P17DIR)		8-13
	(Use inhibited area)				
H'0080 0736	P22 Direction Register (P22DIR)		(Use inhibited area)		8-13
	(Use inhibited area)				
H'0080 0740	P0 Operation Mode Register (P0MOD)		P1 Operation Mode Register (P1MOD)		8-14 8-15
H'0080 0742	P2 Operation Mode Register (P2MOD)		P3 Operation Mode Register (P3MOD)		8-16 8-17
H'0080 0744	P4 Operation Mode Register (P4MOD)		Port Input Special Function Control Register (PICNT)		8-18 8-29
H'0080 0746	(Use inhibited area)		P7 Operation Mode Register (P7MOD)		8-19
H'0080 0748	P8 Operation Mode Register (P8MOD)		P9 Operation Mode Register (P9MOD)		8-20 8-21
H'0080 074A	P10 Operation Mode Register (P10MOD)		P11 Operation Mode Register (P11MOD)		8-22 8-23
H'0080 074C	P12 Operation Mode Register (P12MOD)		P13 Operation Mode Register (P13MOD)		8-24 8-25
H'0080 074E	(Use inhibited area)		P15 Operation Mode Register (P15MOD)		8-26
H'0080 0750	(Use inhibited area)		P17 Operation Mode Register (P17MOD)		8-27
	(Use inhibited area)				
H'0080 0756	P22 Operation Mode Register (P22MOD)		(Use inhibited area)		8-28
	(Use inhibited area)				

## Input/Output Port Related Register Map (3/3)

Address	+0 address		+1 address		See pages
	b0	b7	b8	b15	
H'0080 0760	P0 Peripheral Function Select Register (P0SMOD)		P1 Peripheral Function Select Register (P1SMOD)		8-14 8-15
H'0080 0762	(Use inhibited area)		P3 Peripheral Function Select Register (P3SMOD)		8-17
H'0080 0764	P4 Peripheral Function Select Register (P4SMOD)		(Use inhibited area)		8-18
H'0080 0766	(Use inhibited area)		P7 Peripheral Function Select Register (P7SMOD)		8-19
H'0080 0768	P8 Peripheral Function Select Register (P8SMOD)		P9 Peripheral Function Select Register (P9SMOD)		8-20 8-21
H'0080 076A	P10 Peripheral Function Select Register (P10SMOD)		P11 Peripheral Function Select Register (P11SMOD)		8-22 8-23
H'0080 076C	P12 Peripheral Function Select Register (P12SMOD)		P13 Peripheral Function Select Register (P13SMOD)		8-24 8-25
H'0080 076E	(Use inhibited area)		P15 Peripheral Function Select Register (P15SMOD)		8-26
H'0080 0770	(Use inhibited area)		P17 Peripheral Function Select Register (P17SMOD)		8-27
	(Use inhibited area)				
H'0080 0776	P22 Peripheral Function Select Register (P22SMOD)		(Use inhibited area)		8-28

## 8.3.1 Port Data Registers

P0 Data Register (P0DATA)	<Address: H'0080 0700>
P1 Data Register (P1DATA)	<Address: H'0080 0701>
P2 Data Register (P2DATA)	<Address: H'0080 0702>
P3 Data Register (P3DATA)	<Address: H'0080 0703>
P4 Data Register (P4DATA)	<Address: H'0080 0704>
P6 Data Register (P6DATA)	<Address: H'0080 0706>
P7 Data Register (P7DATA)	<Address: H'0080 0707>
P8 Data Register (P8DATA)	<Address: H'0080 0708>
P9 Data Register (P9DATA)	<Address: H'0080 0709>
P10 Data Register (P10DATA)	<Address: H'0080 070A>
P11 Data Register (P11DATA)	<Address: H'0080 070B>
P12 Data Register (P12DATA)	<Address: H'0080 070C>
P13 Data Register (P13DATA)	<Address: H'0080 070D>
P15 Data Register (P15DATA)	<Address: H'0080 070F>
P17 Data Register (P17DATA)	<Address: H'0080 0711>
P22 Data Register (P22DATA)	<Address: H'0080 0716>

b0	1	2	3	4	5	6	b7
(b8	9	10	11	12	13	14	b15)
Pn0DT	Pn1DT	Pn2DT	Pn3DT	Pn4DT	Pn5DT	Pn6DT	Pn7DT
?	?	?	?	?	?	?	?

Note: • n = 0–13, 15, 17, 22 (not including P5)

<Upon exiting reset: Undefined>

b	Bit Name	Function	R	W
0(8)	Pn0DT Port Pn0 data bit	<At read> Depends on how the Port Direction Register is set	R	W
1(9)	Pn1DT Port Pn1 data bit	If direction bit = "0" (input mode) 0: Port input pin = "L" 1: Port input pin = "H"		
2(10)	Pn2DT Port Pn2 data bit	If direction bit = "1" (output mode) (Note 1) 0: Port output latch = "0" / Port pin level = "L" 1: Port output latch = "1" / Port pin level = "H"		
3(11)	Pn3DT Port Pn3 data bit			
4(12)	Pn4DT Port Pn4 data bit	<At write> Write to the port output latch		
5(13)	Pn5DT Port Pn5 data bit			
6(14)	Pn6DT Port Pn6 data bit			
7(15)	Pn7DT Port Pn7 data bit			

Note 1: To select the port data to read, use the Port Input Special Function Control Register's port input data select bit (PISEL).

Notes: • Following bits are not provided (read as "0," writing has no effect):

- P40, P60, P65–P67, P90–P92, P120–P123, P151, P152, P154–P157, P170–P173, P176, P177, P222, P223, P226, P227
- The SBI# pin input level can be read out by reading the P64DT bit. Writing to the P64DT bit has no effect.
- The MOD0 and MOD1 pin input levels can be read out by reading the P80DT and P81DT bits, respectively. Writing to the P80DT and P81DT bits has no effect.
- P221 is an input-only port. Writing to the P221DT bit has no effect.

## 8.3.2 Port Direction Registers

P0 Direction Register (P0DIR)	<Address: H'0080 0720>
P1 Direction Register (P1DIR)	<Address: H'0080 0721>
P2 Direction Register (P2DIR)	<Address: H'0080 0722>
P3 Direction Register (P3DIR)	<Address: H'0080 0723>
P4 Direction Register (P4DIR)	<Address: H'0080 0724>
P6 Direction Register (P6DIR)	<Address: H'0080 0726>
P7 Direction Register (P7DIR)	<Address: H'0080 0727>
P8 Direction Register (P8DIR)	<Address: H'0080 0728>
P9 Direction Register (P9DIR)	<Address: H'0080 0729>
P10 Direction Register (P10DIR)	<Address: H'0080 072A>
P11 Direction Register (P11DIR)	<Address: H'0080 072B>
P12 Direction Register (P12DIR)	<Address: H'0080 072C>
P13 Direction Register (P13DIR)	<Address: H'0080 072D>
P15 Direction Register (P15DIR)	<Address: H'0080 072F>
P17 Direction Register (P17DIR)	<Address: H'0080 0731>
P22 Direction Register (P22DIR)	<Address: H'0080 0736>

b0	1	2	3	4	5	6	b7
(b8	9	10	11	12	13	14	b15)
Pn0DR	Pn1DR	Pn2DR	Pn3DR	Pn4DR	Pn5DR	Pn6DR	Pn7DR
0	0	0	0	0	0	0	0

Note: • n = 0–13, 15, 17, 22 (not including P5)

<Upon exiting reset: H'00>

b	Bit Name	Function	R	W
0(8)	Pn0DR Port Pn0 direction bit	0: Input mode 1: Output mode	R	W
1(9)	Pn1DR Port Pn1 direction bit			
2(10)	Pn2DR Port Pn2 direction bit			
3(11)	Pn3DR Port Pn3 direction bit			
4(12)	Pn4DR Port Pn4 direction bit			
5(13)	Pn5DR Port Pn5 direction bit			
6(14)	Pn6DR Port Pn6 direction bit			
7(15)	Pn7DR Port Pn7 direction bit			

Notes: • Following bits are not provided (read as 0, writing has no effect):

P40, P60, P64–P67, P80, P81, P90–P92, P120–P123, P151, P152, P154–P157, P170–P173, P176, P177, P222, P223, P226, P227

- All ports are set for input mode upon exiting the reset state.
- P221 is an input-only port. Fix it to "0" when write.
- After switching from output mode to input mode in the Port Direction Register, or after setting port input enable (PIEN0) bit to "1" (input enable), pin level can be read after 2BCLK period.

## 8.3.3 Port Operation Mode and Port Peripheral Function Select Registers

P0 Operation Mode Register (P0MOD)

&lt;Address: H'0080 0740&gt;

b0	1	2	3	4	5	6	b7
P00MD	P01MD	P02MD	P03MD	P04MD	P05MD	P06MD	P07MD
0	0	0	0	0	0	0	0

&lt;Upon exiting reset: H'00&gt;

b	Bit Name	Function	R	W
0	P00MD Port P00 operation mode bit	0: P00/DD0 (Note 1) 1: DB0/TO21 (Note 2)	R	W
1	P01MD Port P01 operation mode bit	0: P01/DD1 (Note 1) 1: DB1/TO22 (Note 2)	R	W
2	P02MD Port P02 operation mode bit	0: P02/DD2 (Note 1) 1: DB2/TO23 (Note 2)	R	W
3	P03MD Port P03 operation mode bit	0: P03/DD3 (Note 1) 1: DB3/TO24 (Note 2)	R	W
4	P04MD Port P04 operation mode bit	0: P04/DD4 (Note 1) 1: DB4/TO25 (Note 2)	R	W
5	P05MD Port P05 operation mode bit	0: P05/DD5 (Note 1) 1: DB5/TO26 (Note 2)	R	W
6	P06MD Port P06 operation mode bit	0: P06/DD6 (Note 1) 1: DB6/TO27 (Note 2)	R	W
7	P07MD Port P07 operation mode bit	0: P07/DD7 (Note 1) 1: DB7/TO28 (Note 2)	R	W

Note 1: The port and DD input functions both are effective. To use the port as DD input pin, set the port direction for input.

Note 2: Which function of the pin is used depends on how the P0 Peripheral Function Select Register is set.

Note: • During processor mode, settings of this register have no effect, and the ports function as external bus interface signal pins (DB0-DB7).

P0 Peripheral Function Select Register (P0SMOD)

&lt;Address: H'0080 0760&gt;

b0	1	2	3	4	5	6	b7
P00SMD	P01SMD	P02SMD	P03SMD	P04SMD	P05SMD	P06SMD	P07SMD
0	0	0	0	0	0	0	0

&lt;Upon exiting reset: H'00&gt;

b	Bit Name	Function	R	W
0	P00SMD Port P00 peripheral function select bit	0: DB0 1: TO21	R	W
1	P01SMD Port P01 peripheral function select bit	0: DB1 1: TO22	R	W
2	P02SMD Port P02 peripheral function select bit	0: DB2 1: TO23	R	W
3	P03SMD Port P03 peripheral function select bit	0: DB3 1: TO24	R	W
4	P04SMD Port P04 peripheral function select bit	0: DB4 1: TO25	R	W
5	P05SMD Port P05 peripheral function select bit	0: DB5 1: TO26	R	W
6	P06SMD Port P06 peripheral function select bit	0: DB6 1: TO27	R	W
7	P07SMD Port P07 peripheral function select bit	0: DB7 1: TO28	R	W

Notes: • During processor mode, settings of this register have no effect, and the ports function as external bus interface signal pins (DB0-DB7).

• The value of this register can only be modified when the corresponding P0 operation mode register bit = 0 (set for port). Then set the corresponding P0 operation mode register bit to "1."

• During single-chip mode, selecting the external bus interface function is prohibited.



P1 Operation Mode Register (P1MOD)

&lt;Address: H'0080 0741&gt;

b8	9	10	11	12	13	14	b15
P10MD	P11MD	P12MD	P13MD	P14MD	P15MD	P16MD	P17MD
0	0	0	0	0	0	0	0

&lt;Upon exiting reset: H'00&gt;

b	Bit Name	Function	R	W
8	P10MD Port P10 operation mode bit	0: P10/DD8 (Note 1) 1: DB8/TO29 (Note 2)	R	W
9	P11MD Port P11 operation mode bit	0: P11/DD9 (Note 1) 1: DB9/TO30 (Note 2)	R	W
10	P12MD Port P12 operation mode bit	0: P12/DD10 (Note 1) 1: DB10/TO31 (Note 2)	R	W
11	P13MD Port P13 operation mode bit	0: P13/DD11 (Note 1) 1: DB11/TO32 (Note 2)	R	W
12	P14MD Port P14 operation mode bit	0: P14/DD12 (Note 1) 1: DB12/TO33 (Note 2)	R	W
13	P15MD Port P15 operation mode bit	0: P15/D13 (Note 1) 1: DB13/TO34 (Note 2)	R	W
14	P16MD Port P16 operation mode bit	0: P16/DD14 (Note 1) 1: DB14/TO35 (Note 2)	R	W
15	P17MD Port P17 operation mode bit	0: P17/DD15 (Note 1) 1: DB15/TO36 (Note 2)	R	W

Note 1: The port and DD input functions both are effective. To use the port as DD input pin, set the port direction for input.

Note 2: Which function of the pin is used depends on how the P1 Peripheral Function Select Register is set.

Note: • During processor mode, settings of this register have no effect, and the ports function as external bus interface signal pins (DB8-DB15).

P1 Peripheral Function Select Register (P1SMOD)

&lt;Address: H'0080 0761&gt;

b8	9	10	11	12	13	14	b15
P10SMD	P11SMD	P12SMD	P13SMD	P14SMD	P15SMD	P16SMD	P17SMD
0	0	0	0	0	0	0	0

&lt;Upon exiting reset: H'00&gt;

b	Bit Name	Function	R	W
8	P10SMD Port P10 peripheral function select bit	0: DB8 1: TO29	R	W
9	P11SMD Port P11 peripheral function select bit	0: DB9 1: TO30	R	W
10	P12SMD Port P12 peripheral function select bit	0: DB10 1: TO31	R	W
11	P13SMD Port P13 peripheral function select bit	0: DB11 1: TO32	R	W
12	P14SMD Port P14 peripheral function select bit	0: DB12 1: TO33	R	W
13	P15SMD Port P15 peripheral function select bit	0: DB13 1: TO34	R	W
14	P16SMD Port P16 peripheral function select bit	0: DB14 1: TO35	R	W
15	P17SMD Port P17 peripheral function select bit	0: DB15 1: TO36	R	W

Notes: • During processor mode, settings of this register have no effect, and the ports function as external bus interface signal pins (DB8-DB15).

• The value of this register can only be modified when the corresponding P1 operation mode register bit = 0 (set for port). Then set the corresponding P1 operation mode register bit to "1."

• During single-chip mode, selecting the external bus interface function is prohibited.

P2 Operation Mode Register (P2MOD)

&lt;Address: H'0080 0742&gt;

b0	1	2	3	4	5	6	b7
P20MD	P21MD	P22MD	P23MD	P24MD	P25MD	P26MD	P27MD
0	0	0	0	0	0	0	0

&lt;Upon exiting reset: H'00&gt;

b	Bit Name	Function	R	W
0	P20MD Port P20 operation mode bit	0: P20/DD24 (Note 1) 1: A23	R	W
1	P21MD Port P21 operation mode bit	0: P21/DD25 (Note 1) 1: A24	R	W
2	P22MD Port P22 operation mode bit	0: P22/DD26 (Note 1) 1: A25	R	W
3	P23MD Port P23 operation mode bit	0: P23/DD27 (Note 1) 1: A26	R	W
4	P24MD Port P24 operation mode bit	0: P24/DD28 (Note 1) 1: A27	R	W
5	P25MD Port P25 operation mode bit	0: P25/DD29 (Note 1) 1: A28	R	W
6	P26MD Port P26 operation mode bit	0: P26/DD30 (Note 1) 1: A29	R	W
7	P27MD Port P27 operation mode bit	0: P27/DD31 (Note 1) 1: A30	R	W

Note 1: The port and DD input functions both are effective. To use the port as DD input pin, set the port direction for input.

Notes: • During single-chip mode, settings of this register have no effect, and the port functions as port input/output or DD input pin.

- During processor mode, settings of this register have no effect, and the ports function as external bus interface signal pins (A23-A30).

P3 Operation Mode Register (P3MOD)

&lt;Address: H'0080 0743&gt;

b8	9	10	11	12	13	14	b15
P30MD	P31MD	P32MD	P33MD	P34MD	P35MD	P36MD	P37MD
0	0	0	0	0	0	0	0

&lt;Upon exiting reset: H'00&gt;

b	Bit Name	Function	R	W
8	P30MD Port P30 operation mode bit	0: P30/DD16 (Note 1) 1: A15/TIN4 (Note 2)	R	W
9	P31MD Port P31 operation mode bit	0: P31/DD17 (Note 1) 1: A16/TIN5 (Note 2)	R	W
10	P32MD Port P32 operation mode bit	0: P32/DD18 (Note 1) 1: A17/TIN6 (Note 2)	R	W
11	P33MD Port P33 operation mode bit	0: P33/DD19 (Note 1) 1: A18/TIN17 (Note 2)	R	W
12	P34MD Port P34 operation mode bit	0: P34/DD20 (Note 1) 1: A19/TIN30 (Note 2)	R	W
13	P35MD Port P35 operation mode bit	0: P35/DD21 (Note 1) 1: A20/TIN31 (Note 2)	R	W
14	P36MD Port P36 operation mode bit	0: P36/DD22 (Note 1) 1: A21/TIN32 (Note 2)	R	W
15	P37MD Port P37 operation mode bit	0: P37/DD23 (Note 1) 1: A22/TIN33 (Note 2)	R	W

Note 1: The port and DD input functions both are effective. To use the port as DD input pin, set the port direction for input.

Note 2: Which function of the pin is used depends on how the P3 Peripheral Function Select Register is set.

Note: • During processor mode, settings of this register have no effect, and the ports function as external bus interface signal pins (A15-A22).

P3 Peripheral Function Select Register (P3SMOD)

&lt;Address: H'0080 0763&gt;

b8	9	10	11	12	13	14	b15
P30SMD	P31SMD	P32SMD	P33SMD	P34SMD	P35SMD	P36SMD	P37SMD
0	0	0	0	0	0	0	0

&lt;Upon exiting reset: H'00&gt;

b	Bit Name	Function	R	W
8	P30SMD Port P30 peripheral function select bit	0: A15 1: TIN4	R	W
9	P31SMD Port P31 peripheral function select bit	0: A16 1: TIN5	R	W
10	P32SMD Port P32 peripheral function select bit	0: A17 1: TIN6	R	W
11	P33SMD Port P33 peripheral function select bit	0: A18 1: TIN7	R	W
12	P34SMD Port P34 peripheral function select bit	0: A19 1: TIN30	R	W
13	P35SMD Port P35 peripheral function select bit	0: A20 1: TIN31	R	W
14	P36SMD Port P36 peripheral function select bit	0: A21 1: TIN32	R	W
15	P37SMD Port P37 peripheral function select bit	0: A22 1: TIN33	R	W

Notes: • During processor mode, settings of this bit have no effect and the ports function as external bus interface signal pins (A15-A22).

- The value of this register can only be modified when the corresponding P3 operation mode register bit = 0 (set for port). Then set the corresponding P3 operation mode register bit to "1."
- During single-chip mode, selecting the external bus interface function is prohibited.

P4 Operation Mode Register (P4MOD)

&lt;Address: H'0080 0744&gt;

b0	1	2	3	4	5	6	b7
0	0	0	0	P44MD	P45MD	P46MD	P47MD
				0	0	0	0

&lt;Upon exiting reset: H'00&gt;

b	Bit Name	Function	R	W
0–3	No function assigned. Fix to "0."		0	0
4	P44MD Port P44 operation mode bit	0: P44 1: CS0#/TIN8 (Note 1)	R	W
5	P45MD Port P45 operation mode bit	0: P45 1: CS1#/TIN9 (Note 1)	R	W
6	P46MD Port P46 operation mode bit	0: P46 1: A13/TIN10 (Note 1)	R	W
7	P47MD Port P47 operation mode bit	0: P47 1: A14/TIN11 (Note 1)	R	W

Note 1: Which function of the pin is used depends on how the P4 Peripheral Function Select Register is set.

Note: • During processor mode, settings of this register have no effect, and the ports function as external bus interface signal pins (CS0#, CS1#, A13 and A14).

P4 Peripheral Function Select Register (P4SMOD)

&lt;Address: H'0080 0764&gt;

b0	1	2	3	4	5	6	b7
0	0	0	0	P44SMD	P45SMD	P46SMD	P47SMD
				0	0	0	0

&lt;Upon exiting reset: H'00&gt;

b	Bit Name	Function	R	W
0–3	No function assigned. Fix to "0."		0	0
4	P44SMD Port P44 peripheral function select bit	0: CS0# 1: TIN8	R	W
5	P45SMD Port P45 peripheral function select bit	0: CS1# 1: TIN9	R	W
6	P46SMD Port P46 peripheral function select bit	0: A13 1: TIN10	R	W
7	P47SMD Port P47 peripheral function select bit	0: A14 1: TIN11	R	W

Notes: • During processor mode, settings of this register have no effect, and the ports function as external bus interface signal pins (CS0#, CS1#, A13 and A14).

- The value of this register can only be modified when the corresponding P4 operation mode register bit = 0 (set for port). Then set the corresponding P4 operation mode register bit to "1."
- During single-chip mode, selecting the external bus interface function is prohibited.

P7 Operation Mode Register (P7MOD)

&lt;Address: H'0080 0747&gt;

b8	9	10	11	12	13	14	b15
P70MD	P71MD	P72MD	P73MD	P74MD	P75MD	P76MD	P77MD
0	0	0	0	0	0	0	0

&lt;Upon exiting reset: H'00&gt;

b	Bit Name	Function	R	W
8	P70MD Port P70 operation mode bit	0: P70 1: CLKOUT/WR#/BCLK (Note 1)	R	W
9	P71MD Port P71 operation mode bit	0: P71 1: WAIT# (Note 2)	R	W
10	P72MD Port P72 operation mode bit	0: P72 1: HREQ#/TIN27 (Note 3)	R	W
11	P73MD Port P73 operation mode bit	0: P73 1: HACK#/TIN26 (Note 3)	R	W
12	P74MD Port P74 operation mode bit (Note 4)	0: P74 1: RTDXTD/TXD3/NBDD0 (Note 3)	R	W
13	P75MD Port P75 operation mode bit (Note 4)	0: P75 1: RTDRXD/RXD3/NBDD1 (Note 3)	R	W
14	P76MD Port P76 operation mode bit (Note 4)	0: P76 1: RTDACK/CTX1/NBDD2 (Note 3)	R	W
15	P77MD Port P77 operation mode bit (Note 4)	0: P77 1: RTDCLK/CRX1/NBDD3 (Note 3)	R	W

Note 1: These functions are selected using the P7 Peripheral Function Select Register and Bus Mode Control Register.

Note 2: During single-chip mode, settings of this register have no effect, and the port functions as port input/output pin.

Note 3: These functions are selected using the P7 Peripheral Function Select Register.

Note 4: If the NBD function is selected by the NBD Pin Control Register, the port functions as NBD pin no matter how this register is set.

P7 Peripheral Function Select Register (P7SMOD)

&lt;Address: H'0080 0767&gt;

b8	9	10	11	12	13	14	b15
P70SMD		P72SMD	P73SMD	P74SMD	P75SMD	P76SMD	P77SMD
0	0	0	0	0	0	0	0

&lt;Upon exiting reset: H'00&gt;

b	Bit Name	Function	R	W
8	P70SMD Port P70 peripheral function select bit	0: CLKOUT/WR# (Note 1) 1: BCLK	R	W
9	No function assigned. Fix to "0."		0	0
10	P72SMD Port P72 peripheral function select bit	0: HREQ# 1: TIN27	R	W
11	P73SMD Port P73 peripheral function select bit	0: HACK# 1: TIN26	R	W
12	P74SMD (Note 2) Port P74 peripheral function select bit	0: RTDXTD 1: TXD3	R	W
13	P75SMD (Note 2) Port P75 peripheral function select bit	0: RTDRXD 1: RXD3	R	W
14	P76SMD (Note 2) Port P76 peripheral function select bit	0: RTDACK 1: CTX1	R	W
15	P77SMD (Note 2) Port P77 peripheral function select bit	0: RTDCLK 1: CRX1	R	W

Note 1: Which function of the pin is used depends on how the Bus Mode Control Register is set.

Note 2: If the NBD function is selected by the NBD Pin Control Register, the port functions as NBD pin no matter how this register is set.

Note: • The value of this register can only be modified when the corresponding P7 operation mode register bit = 0 (set for port). Then set the corresponding P7 operation mode register bit to "1."

P8 Operation Mode Register (P8MOD)

&lt;Address: H'0080 0748&gt;

b0	1	2	3	4	5	6	b7
0	0	P82MD 0	P83MD 0	P84MD 0	P85MD 0	P86MD 0	P87MD 0

&lt;Upon exiting reset: H'00&gt;

b	Bit Name	Function	R	W
0, 1	No function assigned. Fix to "0."		0	0
2	P82MD Port P82 operation mode bit	0: P82 1: TXD0/TO26 (Note 1)	R	W
3	P83MD Port P83 operation mode bit	0: P83 1: RXD0/TO25 (Note 1)	R	W
4	P84MD Port P84 operation mode bit	0: P84 1: SCLKI0/SCLKO0/TO24 (Note 1)	R	W
5	P85MD Port P85 operation mode bit	0: P85 1: TXD1/TO23 (Note 1)	R	W
6	P86MD Port P86 operation mode bit	0: P86 1: RXD1/TO22 (Note 1)	R	W
7	P87MD Port P87 operation mode bit	0: P87 1: SCLKI1/SCLKO1/TO21 (Note 1)	R	W

Note 1: Which function of the pin is used depends on how the P8 Peripheral Function Select Register is set.

P8 Peripheral Function Select Register (P8SMOD)

&lt;Address: H'0080 0768&gt;

b0	1	2	3	4	5	6	b7
0	0	P82SMD 0	P83SMD 0	P84SMD 0	P85SMD 0	P86SMD 0	P87SMD 0

&lt;Upon exiting reset: H'00&gt;

b	Bit Name	Function	R	W
0, 1	No function assigned. Fix to "0."		0	0
2	P82SMD Port P82 peripheral function select bit	0: TXD0 1: TO26	R	W
3	P83SMD Port P83 peripheral function select bit	0: RXD0 1: TO25	R	W
4	P84SMD Port P84 peripheral function select bit	0: SCLKI0/SCLKO0 1: TO24	R	W
5	P85SMD Port P85 peripheral function select bit	0: TXD1 1: TO23	R	W
6	P86SMD Port P86 peripheral function select bit	0: RXD1 1: TO22	R	W
7	P87SMD Port P87 peripheral function select bit	0: SCLKI1/SCLKO1 1: TO21	R	W

Note: • The value of this register can only be modified when the corresponding P8 operation mode register bit = 0 (set for port). Then set the corresponding P8 operation mode register bit to "1."

P9 Operation Mode Register (P9MOD)

&lt;Address: H'0080 0749&gt;

b8	9	10	11	12	13	14	b15
0	0	0	P93MD 0	P94MD 0	P95MD 0	P96MD 0	P97MD 0

&lt;Upon exiting reset: H'00&gt;

b	Bit Name	Function	R	W
8–10	No function assigned. Fix to "0."		0	0
11	P93MD Port P93 operation mode bit	0: P93 1: TO16/SCLKI5/SCLKO5 (Note 2)	R	W
12	P94MD Port P94 operation mode bit	0: P94/DD15 (Note 1) 1: TO17/TXD5 (Note 2)	R	W
13	P95MD Port P95 operation mode bit	0: P95/DD14 (Note 1) 1: TO18/RXD5 (Note 2)	R	W
14	P96MD Port P96 operation mode bit	0: P96/DD13 (Note 1) 1: TO19	R	W
15	P97MD Port P97 operation mode bit	0: P97/DD12 (Note 1) 1: TO20	R	W

Note 1: The port and DD input functions both are effective. To use the port as DD input pin, set the port direction for input.

Note 2: Which function of the pin is used depends on how the P9 Peripheral Function Select Register is set.

P9 Peripheral Function Select Register (P9SMOD)

&lt;Address: H'0080 0769&gt;

b8	9	10	11	12	13	14	b15
0	0	0	P93SMD 0	P94SMD 0	P95SMD 0	0	0

&lt;Upon exiting reset: H'00&gt;

b	Bit Name	Function	R	W
8–10	No function assigned. Fix to "0."		0	0
11	P93SMD Port P93 peripheral function select bit	0: TO16 1: SCLKI5/SCLKO5	R	W
12	P94SMD Port P94 peripheral function select bit	0: TO17 1: TXD5	R	W
13	P95SMD Port P95 peripheral function select bit	0: TO18 1: RXD5	R	W
14, 15	No function assigned. Fix to "0."		0	0

Note: • The value of this register can only be modified when the corresponding P9 operation mode register bit = 0 (set for port). Then set the corresponding P9 operation mode register bit to "1."

P10 Operation Mode Register (P10MOD)

&lt;Address: H'0080 074A&gt;

b0	1	2	3	4	5	6	b7
P100MD	P101MD	P102MD	P103MD	P104MD	P105MD	P106MD	P107MD
0	0	0	0	0	0	0	0

&lt;Upon exiting reset: H'00&gt;

b	Bit Name	Function	R	W
0	P100MD Port P100 operation mode bit	0: P100 1: TO8	R	W
1	P101MD Port P101 operation mode bit	0: P101 1: TO9/CRX0 (Note 1)	R	W
2	P102MD Port P102 operation mode bit	0: P102 1: TO10/CTX0 (Note 1)	R	W
3	P103MD Port P103 operation mode bit	0: P103 1: TO11/TIN24 (Note 1)	R	W
4	P104MD Port P104 operation mode bit	0: P104/DD3 (Note 2) 1: TO12/TIN25 (Note 1)	R	W
5	P105MD Port P105 operation mode bit	0: P105/DD2 (Note 2) 1: TO13/SCLKI4/SCLKO4 (Note 1)	R	W
6	P106MD Port P106 operation mode bit	0: P106/DD1 (Note 2) 1: TO14/TXD4 (Note 1)	R	W
7	P107MD Port P107 operation mode bit	0: P107/DD0 (Note 2) 1: TO15/RXD4 (Note 1)	R	W

Note 1: Which function of the pin is used depends on how the P10 Peripheral Function Select Register is set.

Note 2: The DD input functions are effective depending on the settings of DD input pin select register (DDSEL). (For details, refer to the Chapter 14, "Direct RAM Interface") To use the port as DD input pin, set the port direction for input.

P10 Peripheral Function Select Register (P10SMOD)

&lt;Address: H'0080 076A&gt;

b0	1	2	3	4	5	6	b7
P101SMD	P102SMD	P103SMD	P104SMD	P105SMD	P106SMD	P107SMD	
0	0	0	0	0	0	0	0

&lt;Upon exiting reset: H'00&gt;

b	Bit Name	Function	R	W
0	No function assigned. Fix to "0."		0	0
1	P101SMD Port P101 peripheral function select bit (Note 1)	0: TO9 1: CRX0	R	W
2	P102SMD Port P102 peripheral function select bit	0: TO10 1: CTX0	R	W
3	P103SMD Port P103 peripheral function select bit	0: TO11 1: TIN24	R	W
4	P104SMD Port P104 peripheral function select bit	0: TO12 1: TIN25	R	W
5	P105SMD Port P105 peripheral function select bit	0: TO13 1: SCLKI4/SCLKO4	R	W
6	P106SMD Port P106 peripheral function select bit	0: TO14 1: TXD4	R	W
7	P107SMD Port P107 peripheral function select bit	0: TO15 1: RXD4	R	W

Note 1: When not using this pin as CRX0 pin, always be sure to set the bit to "0."

Note: • The value of this register can only be modified when the corresponding P10 operation mode register bit = 0 (set for port). Then set the corresponding P10 operation mode register bit to "1."



P11 Operation Mode Register (P11MOD)

&lt;Address: H'0080 074B&gt;

b8	9	10	11	12	13	14	b15
P110MD	P111MD	P112MD	P113MD	P114MD	P115MD	P116MD	P117MD
0	0	0	0	0	0	0	0

&lt;Upon exiting reset: H'00&gt;

b	Bit Name	Function	R	W
8	P110MD Port P110 operation mode bit	0: P110/DD11 (Note 1) 1: TO0/TO29 (Note 2)	R	W
9	P111MD Port P111 operation mode bit	0: P111/DD10 (Note 1) 1: TO1/TO30 (Note 2)	R	W
10	P112MD Port P112 operation mode bit	0: P112/DD9 (Note 1) 1: TO2/TO31 (Note 2)	R	W
11	P113MD Port P113 operation mode bit	0: P113/DD8 (Note 1) 1: TO3/TO32 (Note 2)	R	W
12	P114MD Port P114 operation mode bit	0: P114/DD7 (Note 1) 1: TO4/TO33 (Note 2)	R	W
13	P115MD Port P115 operation mode bit	0: P115/DD6 (Note 1) 1: TO5/TO34 (Note 2)	R	W
14	P116MD Port P116 operation mode bit	0: P116/DD5 (Note 1) 1: TO6/TO35 (Note 2)	R	W
15	P117MD Port P117 operation mode bit	0: P117/DD4 (Note 1) 1: TO7/TO36 (Note 2)	R	W

Note 1: The port and DD input functions both are effective. To use the port as DD input pin, set the port direction for input.

Note 2: Which function of the pin is used depends on how the P11 Peripheral Function Select Register is set.

P11 Peripheral Function Select Register (P11SMOD)

&lt;Address: H'0080 076B&gt;

b8	9	10	11	12	13	14	b15
P110SMD	P111SMD	P112SMD	P113SMD	P114SMD	P115SMD	P116SMD	P117SMD
0	0	0	0	0	0	0	0

&lt;Upon exiting reset: H'00&gt;

b	Bit Name	Function	R	W
8	P110SMD Port P110 peripheral function select bit	0: TO0 1: TO29	R	W
9	P111SMD Port P111 peripheral function select bit	0: TO1 1: TO30	R	W
10	P112SMD Port P112 peripheral function select bit	0: TO2 1: TO31	R	W
11	P113SMD Port P113 peripheral function select bit	0: TO3 1: TO32	R	W
12	P114SMD Port P114 peripheral function select bit	0: TO4 1: TO33	R	W
13	P115SMD Port P115 peripheral function select bit	0: TO5 1: TO34	R	W
14	P116SMD Port P116 peripheral function select bit	0: TO6 1: TO35	R	W
15	P117SMD Port P117 peripheral function select bit	0: TO7 1: TO36	R	W

Note: • The value of this register can only be modified when the corresponding P11 operation mode register bit = 0 (set for port). Then set the corresponding P11 operation mode register bit to "1."

P12 Operation Mode Register (P12MOD)

&lt;Address: H'0080 074C&gt;

b0	1	2	3	4	5	6	b7
				P124MD	P125MD	P126MD	P127MD
0				0	0	0	0

&lt;Upon exiting reset: H'00&gt;

b	Bit Name	Function	R	W
0–3	No function assigned. Fix to "0."		0	0
4	P124MD Port P124 operation mode bit (Note 3)	0: P124/DD3 (Note 1) 1: TCLK0/A9 (Note 2)	R	W
5	P125MD Port P125 operation mode bit (Note 3)	0: P125/DD2 (Note 1) 1: TCLK1/A10 (Note 2)	R	W
6	P126MD Port P126 operation mode bit	0: P126/DD1 (Note 1) 1: TCLK2/CS2# (Note 2)	R	W
7	P127MD Port P127 operation mode bit	0: P127/DD0 (Note 1) 1: TCLK3/CS3# (Note 2)	R	W

Note 1: The DD input functions are effective depending on the settings of DD input pin select register (DDSEL). (For details, refer to the Chapter 14, "Direct RAM Interface") To use the port as DD input pin, set the port direction for input.

Note 2: Which function of the pin is used depends on how the P12 Peripheral Function Select Register is set.

Note 3: During processor mode, settings of this bit have no effect and the port functions as external bus interface signal pin (A9 or A10).

P12 Peripheral Function Select Register (P12SMOD)

&lt;Address: H'0080 076C&gt;

b0	1	2	3	4	5	6	b7
				P124SMD	P125SMD	P126SMD	P127SMD
0				0	0	0	0

&lt;Upon exiting reset: H'00&gt;

b	Bit Name	Function	R	W
0–3	No function assigned. Fix to "0."		0	0
4	P124SMD Port P124 peripheral function select bit (Note 1)	0: TCLK0 1: A9	R	W
5	P125SMD Port P125 peripheral function select bit (Note 1)	0: TCLK1 1: A10	R	W
6	P126SMD Port P126 peripheral function select bit	0: TCLK2 1: CS2#	R	W
7	P127SMD Port P127 peripheral function select bit	0: TCLK3 1: CS3#	R	W

Note 1: During processor mode, settings of this bit have no effect and the port functions as external bus interface signal pin (A9 or A10).

Note: • The value of this register can only be modified when the corresponding P12 operation mode register bit = 0 (set for port). Then set the corresponding P12 operation mode register bit to "1."

P13 Operation Mode Register (P13MOD)

&lt;Address: H'0080 074D&gt;

b8	9	10	11	12	13	14	b15
P130MD	P131MD	P132MD	P133MD	P134MD	P135MD	P136MD	P137MD
0	0	0	0	0	0	0	0

&lt;Upon exiting reset: H'00&gt;

b	Bit Name	Function	R	W
8	P130MD Port P130 operation mode bit	0: P130 1: TIN16/PWMOFF0/DIN0 (Note 1)	R	W
9	P131MD Port P131 operation mode bit	0: P131 1: TIN17/PWMOFF1/DIN1 (Note 1)	R	W
10	P132MD Port P132 operation mode bit	0: P132 1: TIN18/DIN2 (Note 2)	R	W
11	P133MD Port P133 operation mode bit	0: P133 1: TIN19/DIN3 (Note 2)	R	W
12	P134MD Port P134 operation mode bit	0: P134 1: TIN20/TXD3/DIN4 (Note 3)	R	W
13	P135MD Port P135 operation mode bit	0: P135 1: TIN21/RXD3 (Note 3)	R	W
14	P136MD Port P136 operation mode bit	0: P136 1: TIN22/CRX1 (Note 3)	R	W
15	P137MD Port P137 operation mode bit	0: P137 1: TIN23/CTX1 (Note 3)	R	W

Note 1: TIN input, DIN input, and PWMOFF input functions all are effective.

Note 2: TIN input and DIN input functions both are effective.

Note 3: Which function of the pin is used depends on how the P13 Peripheral Function Select Register is set.

P13 Peripheral Function Select Register (P13SMOD)

&lt;Address: H'0080 076D&gt;

b8	9	10	11	12	13	14	b15
				P134SMD	P135SMD	P136SMD	P137SMD
0	0	0	0	0	0	0	0

&lt;Upon exiting reset: H'00&gt;

b	Bit Name	Function	R	W
8–11	No function assigned. Fix to "0."		0	0
12	P134SMD Port P134 peripheral function select bit	0: TIN20/DIN4 (Note 1) 1: TXD3	R	W
13	P135SMD Port P135 peripheral function select bit (Note 2)	0: TIN21 1: RXD3	R	W
14	P136SMD Port P136 peripheral function select bit (Note 3)	0: TIN22 1: CRX1	R	W
15	P137SMD Port P137 peripheral function select bit	0: TIN23 1: CTX1	R	W

Note 1: TIN input and DIN input functions both are effective.

Note 2: When not using this pin as RXD3 pin, always be sure to set the bit to "0."

Note 3: When not using this pin as CRX1 pin, always be sure to set the bit to "0."

Note: • The value of this register can only be modified when the corresponding P13 operation mode register bit = 0 (set for port). Then set the corresponding P13 operation mode register bit to "1."

P15 Operation Mode Register (P15MOD)

&lt;Address: H'0080 074F&gt;

b8	9	10	11	12	13	14	b15
P150MD			P153MD				
0	0	0	0	0	0	0	0

&lt;Upon exiting reset: H'00&gt;

b	Bit Name	Function	R	W
8	P150MD Port P150 operation mode bit	0: P150 1: TIN0/CLKOUT/WR# (Note 1)	R	W
9, 10	No function assigned. Fix to "0."		0	0
11	P153MD Port P153 operation mode bit	0: P153 1: TIN3/WAIT# (Note 2)	R	W
12–15	No function assigned. Fix to "0."		0	0

Note 1: Which function of the pin is used depends on how the P15 Peripheral Function Select Register and Bus Mode Control Register are set.

Note 2: Which function of the pin is used depends on how the P15 Peripheral Function Select Register is set.

P15 Peripheral Function Select Register (P15SMD)

&lt;Address: H'0080 076F&gt;

b8	9	10	11	12	13	14	b15
P150SMD			P153SMD				
0	0	0	0	0	0	0	0

&lt;Upon exiting reset: H'00&gt;

b	Bit Name	Function	R	W
8	P150SMD Port P150 peripheral function select bit	0: TIN0 1: CLKOUT/WR# (Note 1)	R	W
9, 10	No function assigned. Fix to "0."		0	0
11	P153SMD Port P153 peripheral function select bit (Note 2)	0: TIN3 1: WAIT#	R	W
12–15	No function assigned. Fix to "0."		0	0

Note 1: Which function of the pin is used depends on how the Bus Mode Control Register is set.

Note 2: During single-chip mode, selecting the external bus interface signal function is prohibited.

Note: • The value of this register can only be modified when the corresponding P15 operation mode register bit = 0 (set for port). Then set the corresponding P15 operation mode register bit to "1."

P17 Operation Mode Register (P17MOD)

&lt;Address: H'0080 0751&gt;

b8	9	10	11	12	13	14	b15
0	0	0	0	P174MD 0	P175MD 0	0	0

&lt;Upon exiting reset: H'00&gt;

b	Bit Name	Function	R	W
8–11	No function assigned. Fix to "0."		0	0
12	P174MD Port P174 operation mode bit	0: P174 1: TXD2/TO28 (Note 1)	R	W
13	P175MD Port P175 operation mode bit	0: P175 1: RXD2/TO27 (Note 1)	R	W
14, 15	No function assigned. Fix to "0."		0	0

Note 1: Which function of the pin is used depends on how the P17 Peripheral Function Select Register is set.

P17 Peripheral Function Select Register (P17SMOD)

&lt;Address: H'0080 0771&gt;

b8	9	10	11	12	13	14	b15
0	0	0	0	P174SMD 0	P175SMD 0	0	0

&lt;Upon exiting reset: H'00&gt;

b	Bit Name	Function	R	W
8–11	No function assigned. Fix to "0."		0	0
12	P174SMD Port P174 peripheral function select bit	0: TXD2 1: TO28	R	W
13	P175SMD Port P175 peripheral function select bit	0: RXD2 1: TO27	R	W
14, 15	No function assigned. Fix to "0."		0	0

Note: • The value of this register can only be modified when the corresponding P17 operation mode register bit = 0 (set for port). Then set the corresponding P17 operation mode register bit to "1."

P22 Operation Mode Register (P22MOD)

&lt;Address: H'0080 0756&gt;

b0	1	2	3	4	5	6	b7
P220MD	P221MD			P224MD	P225MD		
0	0	0	0	0	0	0	0

&lt;Upon exiting reset: H'00&gt;

b	Bit Name	Function	R	W
0	P220MD Port P220 operation mode bit	0: P220 1: CTX0/HACK# (Note 1)	R	W
1	P221MD Port P221 operation mode bit	0: P221 1: CRX0/HREQ# (Note 1)	R	W
2, 3	No function assigned. Fix to "0."		0	0
4	P224MD Port P224 operation mode bit (Note 2)	0: P224 1: A11/CS2# (Note 1)	R	W
5	P225MD Port P225 operation mode bit (Note 2)	0: P225 1: A12/CS3# (Note 1)	R	W
6, 7	No function assigned. Fix to "0."		0	0

Note 1: Which function of the pin is used depends on how the P22 Peripheral Function Select Register is set.

Note 2: During processor mode, settings of this bit have no effect and the port functions as external bus interface signal pin (A11/CS2# or A12/CS3#).

P22 Peripheral Function Select Register (P22SMOD)

&lt;Address: H'0080 0776&gt;

b0	1	2	3	4	5	6	b7
P220SMD	P221SMD			P224SMD	P225SMD		
0	0	0	0	0	0	0	0

&lt;Upon exiting reset: H'00&gt;

b	Bit Name	Function	R	W
0	P220SMD Port P220 peripheral function select bit	0: CTX0 1: HACK#	R	W
1	P221SMD Port P221 peripheral function select bit	0: CRX0 1: HREQ#	R	W
2, 3	No function assigned. Fix to "0."		0	0
4	P224SMD Port P224 peripheral function select bit (Note 1)	0: A11 1: CS2#	R	W
5	P225SMD Port P225 peripheral function select bit (Note 1)	0: A12 1: CS3#	R	W
6, 7	No function assigned. Fix to "0."		0	0

Note 1: During single-chip mode, selecting the external bus interface signal function is prohibited.

Note: • The value of this register can only be modified when the corresponding P22 operation mode register bit = 0 (set for port). Then set the corresponding P22 operation mode register bit to "1."

## 8.3.4 Port Input Special Function Control Register

Port Input Special Function Control Register (PICNT)

&lt;Address: H'0080 0745&gt;

b8	9	10	11	12	13	14	b15
0	0	0	XSTAT 0	0	0	PISEL 0	PIEN0 0

&lt;Upon exiting reset: H'00&gt;

b	Bit Name	Function	R	W
8–10	No function assigned. Fix to "0."		0	0
11	XSTAT XIN oscillation status bit	0: XIN oscillating 1: XIN inactive	R (Note 1)	
12, 13	No function assigned. Fix to "0."		0	0
14	PISEL Port input data select bit	0: Content of port output latch 1: Port pin level	R	W
15	PIEN0 Port input enable bit	0: Disable input 1: Enable input	R	W

Note 1: Only writing "0" is effective. Writing "1" has no effect; the bit retains the value it had before the write.

Note 2: After switching from output mode to input mode in the Port Direction Register, or after setting port input enable (PIEN0) bit to "1" (input enable), pin level can be read after 2BCLK period.

## (1) XSTAT (XIN oscillation status) bit (Bit 11)

## • Conditions under which XSTAT bit is set to "1"

XSTAT bit is set to "1" upon detecting that XIN oscillation has stopped. When XIN remains at the same level for a predetermined time (3 BCLK periods up to 4 BCLK periods) on the basis of threshold, XIN oscillation is assumed to have stopped. When operating normally, XIN changes state (high or low) once every BCLK period.

## • Conditions under which XSTAT bit is cleared to "0"

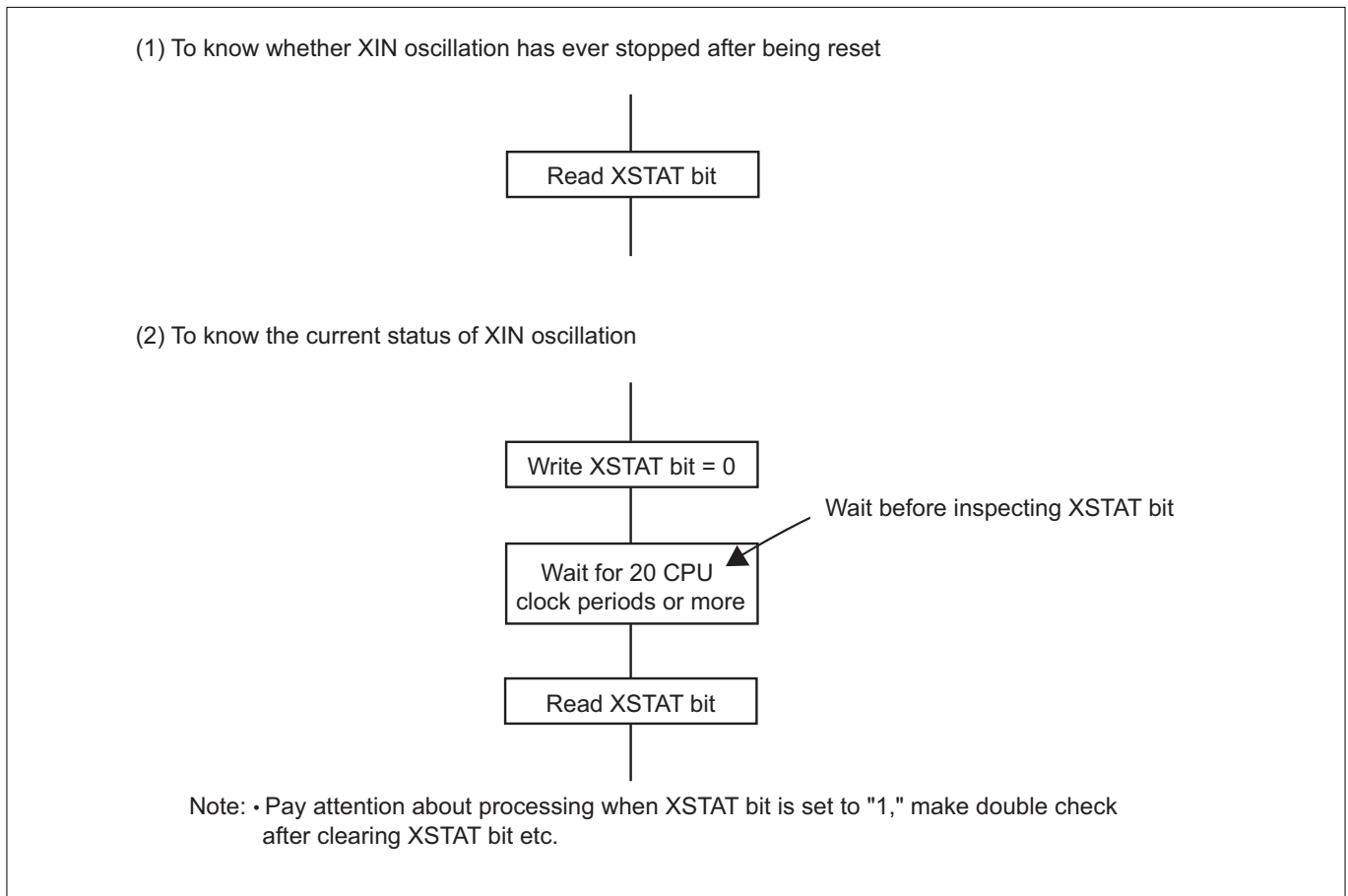
XSTAT bit is cleared to "0" by a system reset or by writing "0." If XSTAT bit is cleared at the same time it is set above, the former has priority. Writing "1" to XSTAT bit is ignored.

## • Method for using XSTAT bit to detect XIN oscillation stoppage

Because the M32R/ECU internally contains a PLL, the internal clock remains active even when XIN oscillation has stopped.

By reading XSTAT bit without clearing it once after exiting the reset state, it is possible to know whether XIN has ever stopped since the reset signal was deasserted. Similarly, by reading XSTAT bit after clearing it by writing "0," it is possible to know the current oscillating status of XIN. However, there must be an interval of at least 5 BCLK periods (20 CPU clock periods) between read and write.

Pay attention about processing when XSTAT bit is set to "1," make double check after clearing XSTAT bit etc.



**Figure 8.3.1 Procedure for Setting XSTAT**

### (2) PISEL (Port input data select) bit (Bit 14)

When the Port Direction Register is set for output, this bit selects the target data to be read from the Port Data Register. At this time, this bit is unaffected by the Port Operation Mode Register.

**Table 8.3.1 PISEL Bit Settings and the Target Data To Be Read from the Port Data Register**

Direction Register	PISEL Settings	Target Data to Be Read
0 (input)	0/1	Port pin level
1 (output)	0	Port output latch
	1	Port pin level



**(3) PIEN0 (Port input enable) bit (Bit 15)**

This bit is used to prevent shoot-through current from flowing into the port input pins.

Because the input/output ports are disabled against input upon exiting reset, if any ports need to be used in input mode they must be enabled for input by setting this bit to "1."

When disabled against input, the input/output ports are in a state equivalent to a situation where the pin has a low-level input applied. Consequently, if a peripheral input function (uncontrolled pin) is selected for any port while disabled against input by using the Port Operation Mode Register, the port may operate unexpectedly due to the "L" level input on it.

The following shows the procedure for selecting a peripheral input function.

- (1) Enable the port for input when its pin level is valid (high or low)
- (2) Select a function using the port operation mode bit

During boot mode, the pins shared with serial interface functions are enabled for input and can therefore be protected against shoot-through current flowing in from the pins other than serial interface functions during flash programming by clearing PIEN0.

The table below lists the pins that can be controlled by the PIEN0 bit in each operation mode.

**Table 8.3.2 Pins Controllable by Port Input Enable Bit**

Mode Name	Controllable Pins	Uncontrolled Pins
Single-chip	P00–P07, P10–P17, P20–P27 P30–P37, P41–P47, P61–P63 P70–P77, P82–P87, P93–P97 P100–P107, P110–P117, P124–P127 P130–P137, P150, P153, P174, P175 P220, P224, P225	P221, FP, SBI#, MOD0, MOD1, MOD2, RESET#
External extension Microprocessor	P61–P63, P70–P77, P82–P87 P93–P97, P100–P107, P110–P117 P126, P127, P130–P137 P150, P153, P174, P175, P220	P00–P07, P10–P17 P20–P27, P30–P37 P41–P47, P124, P125, P221, P224, P225 FP, SBI#, MOD0, MOD1, MOD2, RESET#
Boot (single-chip)	P00–P07, P10–P17, P20–P27 P30–P37, P41–P47, P61–P63 P70–P77, P93–P97, P100–P107 P110–P117, P124–P127, P130–P137 P150, P153, P220, P224, P225	P82–P87, P174, P175, P221 FP, SBI#, MOD0, MOD1, MOD2, RESET#

## 8.4 Port Input Level Switching Function

The port input level switching function allows the port threshold to be switched to one of three voltage levels (with or without Schmitt as selected) in units of the following port group. This can be set to the following registers in units of group. Note that port inputs are used for the DD input of DRI.

Port Group 0: P00–P07, P10–P17, P20–P27, P30–P37, P41–P47, P70–P73, P224, P225

Port Group 1: P82–P87, P174, P175

Port Group 3: P93–P97, P110–P117

Port Group 4: P124–P127

Port Group 5: P61–P63, SBI#

Port Group 6: P74–P77, P100–P107

Port Group 7: P220, P221

Port Group 8: P130–P137, P150, P153

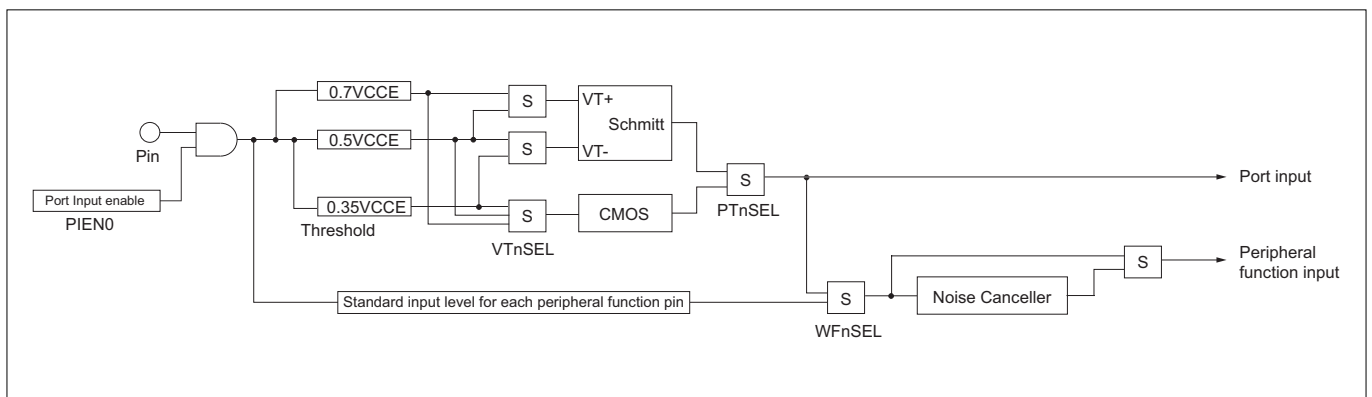


Figure 8.4.1 Port Input Level Switching Function

Port Group 0,1 Input Level Setting Register (PG01LEV)

&lt;Address: H'0080 0500&gt;

b0	1	2	3	4	5	6	b7
WF0SEL	PT0SEL	VT0SEL0	VT0SEL1	WF1SEL	PT1SEL	VT1SEL0	VT1SEL1
0	0	0	1	0	0	0	1

Port Group 3 Input Level Setting Register (PG3LEV)

&lt;Address: H'0080 0501&gt;

b8	9	10	11	12	13	14	b15
				WF3SEL	PT3SEL	VT3SEL0	VT3SEL1
0	0	0	0	0	0	0	1

Note: • The PG3LEV register bits 8–11 have no functions assigned.

Port Group 4,5 Input Level Setting Register (PG45LEV)

&lt;Address: H'0080 0502&gt;

b0	1	2	3	4	5	6	b7
WF4SEL	PT4SEL	VT4SEL0	VT4SEL1	WF5SEL	PT5SEL	VT5SEL0	VT5SEL1
0	0	0	1	0	0	0	1

Port Group 6,7 Input Level Setting Register (PG67LEV)

&lt;Address: H'0080 0503&gt;

b8	9	10	11	12	13	14	b15
WF6SEL	PT6SEL	VT6SEL0	VT6SEL1	WF7SEL	PT7SEL	VT7SEL0	VT7SEL1
0	0	0	1	0	0	0	1

Port Group 8 Input Level Setting Register (PG8LEV)

&lt;Address: H'0080 0504&gt;

b0	1	2	3	4	5	6	b7
WF8SEL	PT8SEL	VT8SEL0	VT8SEL1				
0	0	0	1	0	0	0	0

Note: • The PG8LEV register bits 4–7 have no functions assigned.

&lt;Upon exiting reset: :H'11, H'01, H'10&gt; (Note 2)

b	Bit Name	Function	R	W
0(4)	WF <sub>n</sub> SEL (Note 1)	0: Select standard input for each pin	R	W
8(12)	Group n dual-function input select bit	1: Select threshold switching function		
1-3	PT <sub>n</sub> SEL	000 : FInput CMOS, Select 0.35VCCE	R	W
(9 ~ 11)	(Group n port input select bit )	001 : Input CMOS, Select 0.50VCCE		
	VT <sub>n</sub> SEL0, VT <sub>n</sub> SEL1	010 : Input CMOS, Select 0.70VCCE		
	(Group n input threshold select bit)	011 : Settings inhibited		
		100 : Schmitt input , VT += 0.50VCCE, VT -= 0.35VCCE		
		101 : Settings inhibited		
		110 : Schmitt input , VT += 0.70VCCE, VT -= 0.35VCCE		
		111 : Schmitt input , VT += 0.70VCCE, VT -= 0.50VCCE		
4(12)	WF <sub>n</sub> SEL (Note 1)	0 : Select standard input for each pin	R	W
	Group n dual-function input select bit	1 : Select threshold switching function		
5 ~ 7	PT <sub>n</sub> SEL	000 : Input CMOS, Select 0.35VCCE	R	W
(13 ~ 15)	(Group n port input select bit)	001 : Input CMOS, Select 0.50VCCE		
	VT <sub>n</sub> SEL0, VT <sub>n</sub> SEL1	010 : Input CMOS, Select 0.70VCCE		
	(Group n input threshold select bit)	011 : Settings inhibited		
		100 : Schmitt input , VT += 0.50VCCE, AVT -= 0.35VCCE		
		101 : Settings inhibited		
		110 : Schmitt input , VT += 0.70VCCE, AVT -= 0.35VCCE		
		111 : Schmitt input , VT += 0.70VCCE, AVT -= 0.50VCCE		

Note 1. When the multipurpose port function pin is selected (Set bit corresponding Px operation mode register(PxMOD) to "0"), setting value for WF<sub>n</sub>SEL is invalid and threshold switch function is effective.Note 2. Upon exiting reset, VT<sub>n</sub>SEL1 bit value is "1" and the other bit is set to "0."

## 8.5 Port Output Drive Capability Setting Function

This function sets the drive capability of output pins by selecting high or low drive power, one port group at a time.

Port Group 0: P00–P07, P10–P17, P20–P27, P30–P37, P41–P47, P70–P73, P224, P225

Port Group 1: P82–P87, P174, P175

Port Group 3: P93–P97, P110–P117

Port Group 4: P124–P127

Port Group 5: P61–P63, SBI#

Port Group 6: P74–P77, P100–P107

Port Group 7: P220, P221

Port Group 8: P130–P137, P150, P153

Port Group 0,1 Output Drive Capability Setting Register (PG01DRV)

&lt;Address: H'0080 0508&gt;

b0	1	2	3	4	5	6	b7
0			G0DSEL 0	0			G1DSEL 0

Port Group 3 Output Drive Capability Setting Register (PG3DRV)

&lt;Address: H'0080 0509&gt;

b8	9	10	11	12	13	14	b15
0							G3DSEL 0

Note: • The PG3DRV register bits 8–14 have no functions assigned.

Port Group 4,5 Output Drive Capability Setting Register (PG45DRV)

&lt;Address: H'0080 050A&gt;

b0	1	2	3	4	5	6	b7
0			G4DSEL 0	0			G5DSEL 0

Port Group 6,7 Output Drive Capability Setting Register (PG67DRV)

&lt;Address: H'0080 050B&gt;

b8	9	10	11	12	13	14	b15
0			G6DSEL 0	0			G7DSEL 0

Port Group 8 Output Drive Capability Setting Register (PG8DRV)

&lt;Address: H'0080 050C&gt;

b0	1	2	3	4	5	6	b7
0			G8DSEL 0	0			

Note: • The PG8DRV register bits 4–7 have no functions assigned.

&lt;Upon exiting reset: H'00&gt;

b	Bit Name	Function	R	W
0–2 (8–10)	No function assigned. Fix to "0."		0	0
3 (11)	GnDSEL (Note 1) Group n output drive capability select bit	0: 50% 1: 100%	R	W
4–6 (12–14)	No function assigned. Fix to "0."		0	0
3 (15)	GnDSEL (Note 1) Group n output drive capability select bit	0: 50% 1: 100%	R	W

Note 1: The 50% drive capability is equivalent to that of the M32R/ECU Series without the port output drive capability setting function.

Note: • For the P70/CLKOUT/WR#/BCLK pin, the drive capability can be set to one of four capability levels by using the P70 Output Drive Capability Setting Register. Note that 50% of GnDSEL bit and 50% of P70DSEL bit drive capabilities are equivalent.

P70 Output Drive Capability Setting Register (P70DRV)

&lt;Address: H'0080 050D&gt;

b8	9	10	11	12	13	14	b15
					P70DSELEN	P70DSEL	
0	0	0	0	0	0	0	0

&lt;Upon exiting reset: H'00&gt;

b	Bit Name	Function	R	W
8–12	No function assigned. Fix to "0."		0	0
13	P70DSELEN (Note 1) P70 output drive capability setting enable bit	0: Disable setting 1: Enable setting	R	W
14, 15	P70DSEL (Note 2)(Note 3) P70 output drive capability setting bit	00: 25% 01: 50% 10: 75% 11: 100%	R	W

low  
↑  
↓  
high

Note 1: Setting this bit to "0" nullifies settings made to this register, so that the drive capability set by the Group 0,1 Output Drive Capability Setting Register is assumed.

When this bit is set to "1," settings of the Group 0,1 Output Drive Capability Setting Register have no effect and the drive capability is controlled by the P70DSEL bit.

Note 2: This bit selects the drive capability of the P70/CLKOUT/WR#/BCLK pin. For settings of this bit to take effect, the P70DSELEN bit must be set to "1."

Note 3: The 50% drive capability is equivalent to that of the M32R/ECU Series without the port output drive capability setting function.

Note : • For the pins other than the P70/CLKOUT/WR#/BCLK pin, the drive capability can be set by using the Port Group Output Drive Capability Setting Registers. Note that 50% of GnDSEL and 50% of P70DSEL drive capabilities are equivalent.

## 8.6 Noise Canceller Control Function

The Noise Canceller Control Register allows to select whether the noise canceller for the input signal to each peripheral module to be used or not, one port group at a time. Note that port inputs are used for the DD input of DRI.

- Port Group 0: TIN26, TIN27, TIN4–TIN11, TIN30–TIN33
- Port Group 1: RXD0, SCLKI0, RXD1, SCLKI1, RXD2
- Port Group 2: None
- Port Group 3: SCLKI5, RXD5
- Port Group 4: TCLK0–TCLK3
- Port Group 5: None
- Port Group 6: RTDRXD, RTDCLK, RXD3, TIN24, TIN25, SCLKI4, RXD4
- Port Group 7: None
- Port Group 8: TIN16–TIN23, PWMOFF0, PWMOFF1, TIN0, TIN3

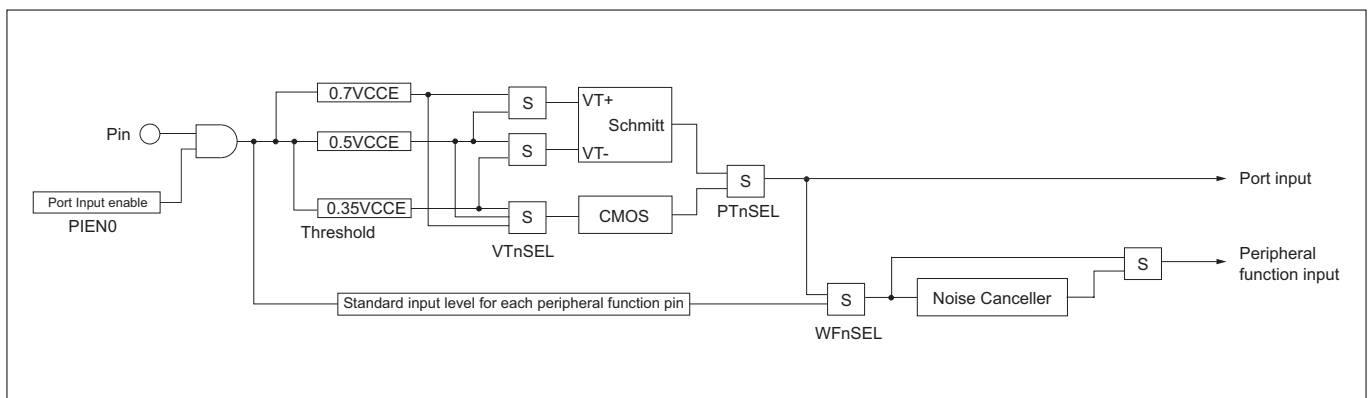


Figure 8.6.1 Noise Canceller Control Function

Noise Canceller Control Register (NZCNLCR)

&lt;Address: H'0080 0510&gt;

b0	1	2	3	4	5	6	7	8	9	10	11	12	13	14	b15
G0NSEL	G1NSEL		G3NSEL	G4NSEL		G6NSEL		G8NSEL							
0	0	0	0	0	0	0	0	0	0	0	0	0	0	0	0

&lt;Upon exiting reset: H'0000&gt;

b	Bit Name	Function	R	W
0	G0NSEL Group 0 noise canceller disable bit	0: Group 0 noise canceller used 1: Group 0 noise canceller not used	R	W
1	G1NSEL Group 1 noise canceller disable bit	0: Group 1 noise canceller used 1: Group 1 noise canceller not used	R	W
2	No function assigned. Fix to "0."		0	0
3	G3NSEL Group 3 noise canceller disable bit	0: Group 3 noise canceller used 1: Group 3 noise canceller not used	R	W
4	G4NSEL Group 4 noise canceller disable bit	0: Group 4 noise canceller used 1: Group 4 noise canceller not used	R	W
5	No function assigned. Fix to "0."		0	0
6	G6NSEL Group 6 noise canceller disable bit	0: Group 6 noise canceller used 1: Group 6 noise canceller not used	R	W
7	No function assigned. Fix to "0."		0	0
8	G8NSEL Group 8 noise canceller disable bit	0: Group 8 noise canceller used 1: Group 8 noise canceller not used	R	W
9–15	No function assigned. Fix to "0."		0	0

Note: • This register must always be accessed in halfwords.



## 8.7 Port Peripheral Circuits

Figures 8.7.1 through 8.7.5 show the peripheral circuit diagrams of the input/output ports described in the preceding pages.

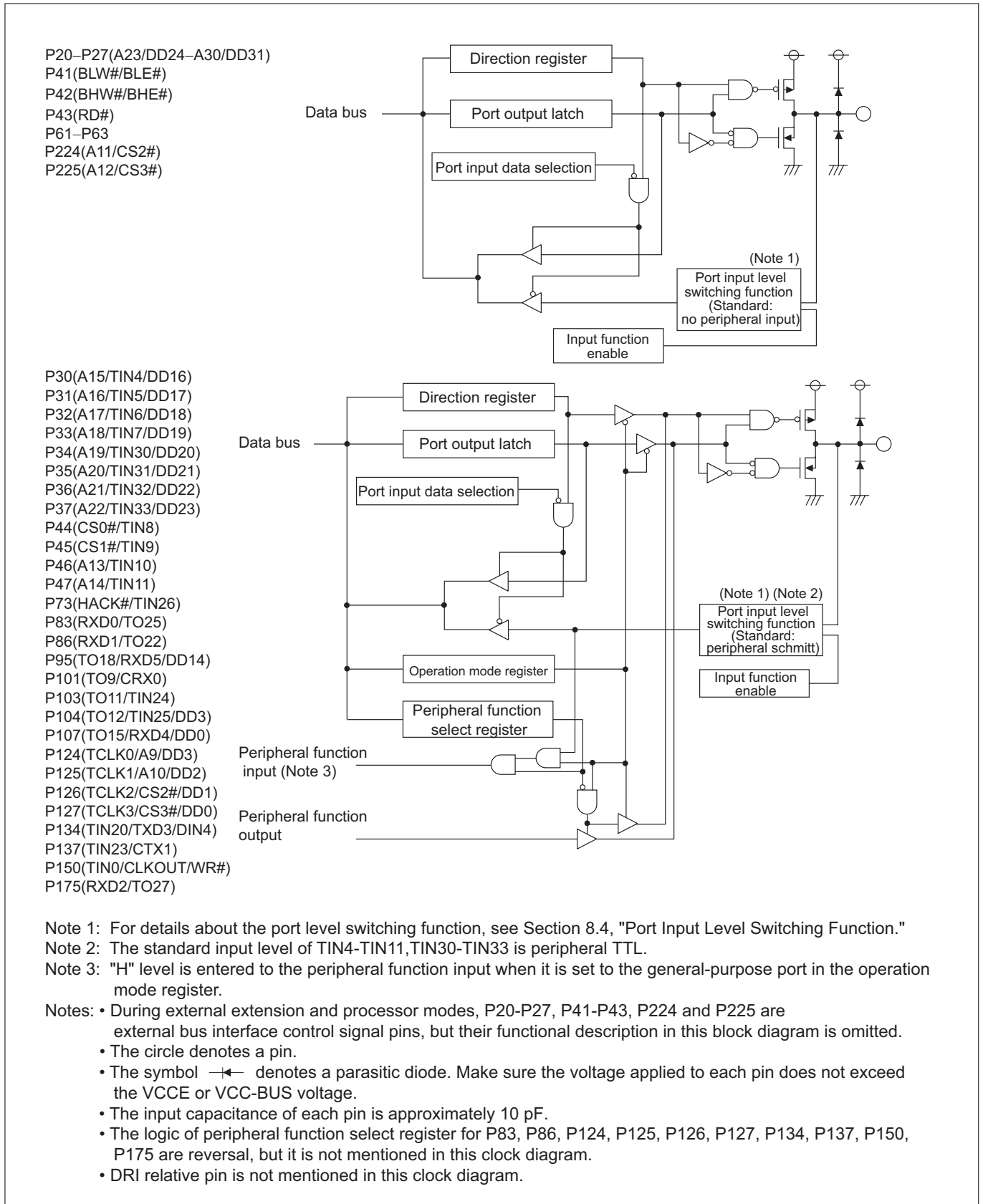


Figure 8.7.1 Port Peripheral Circuit Diagram (1)

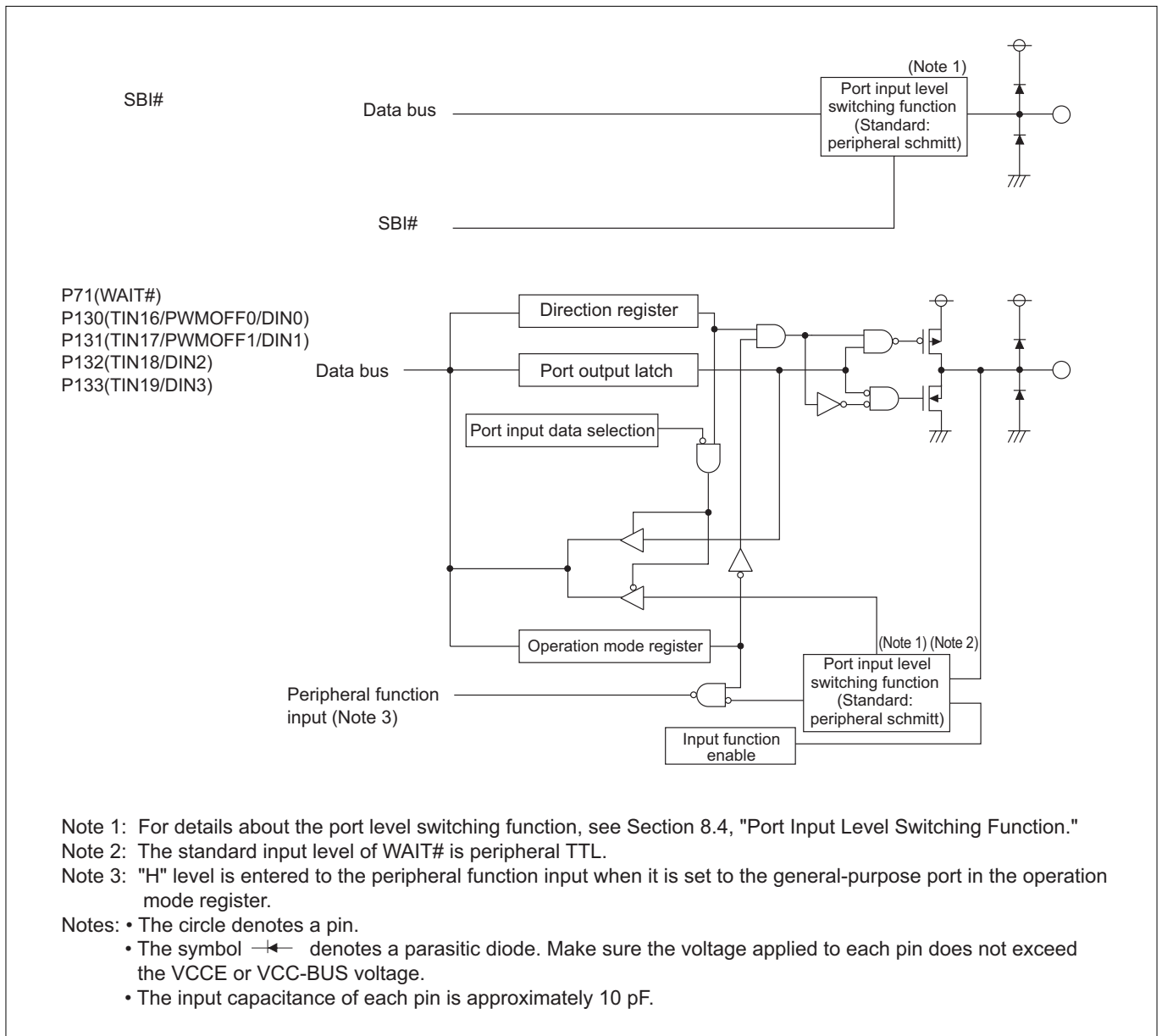


Figure 8.7.2 Port Peripheral Circuit Diagram (2)

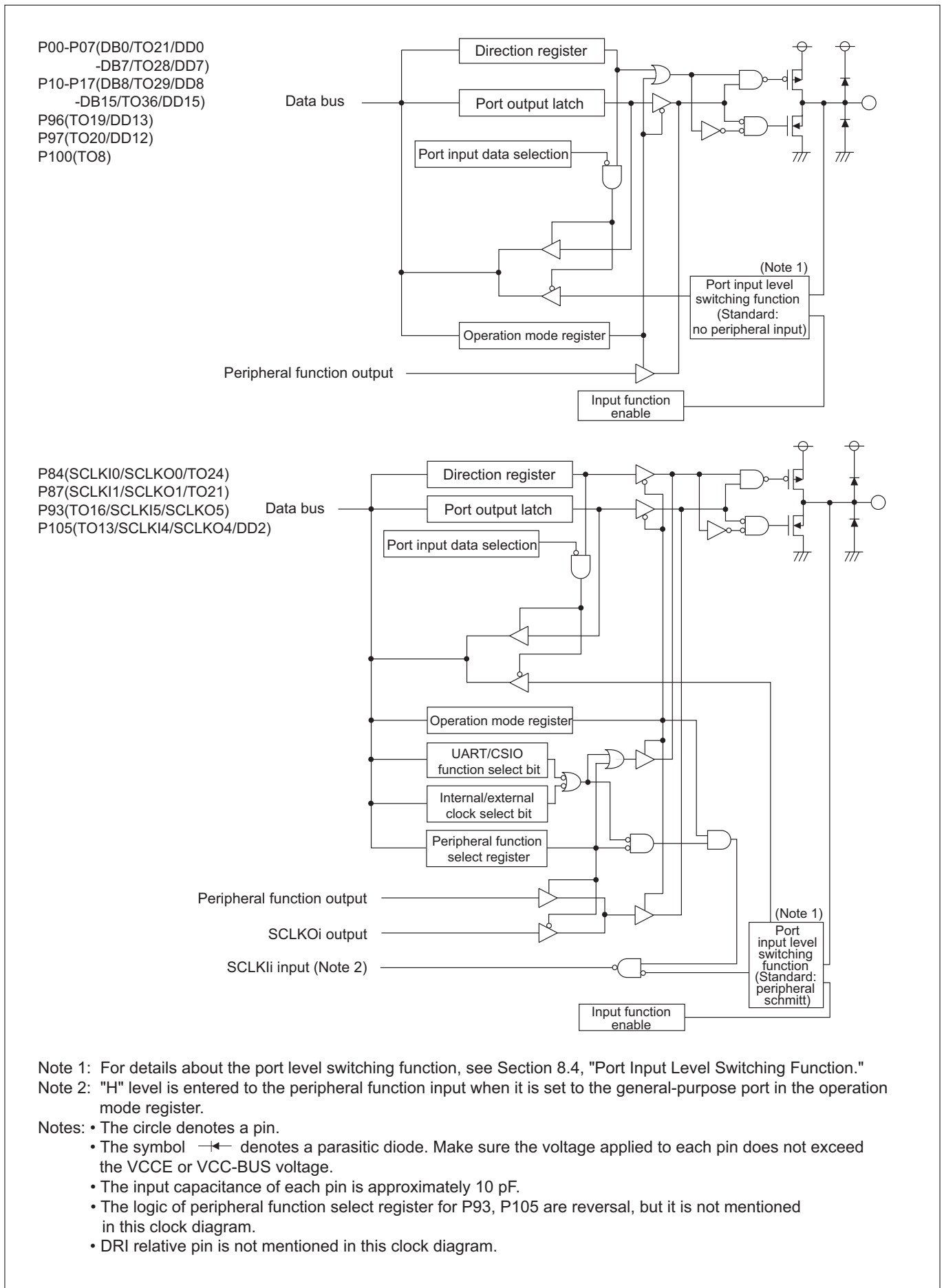


Figure 8.7.3 Port Peripheral Circuit Diagram (3)

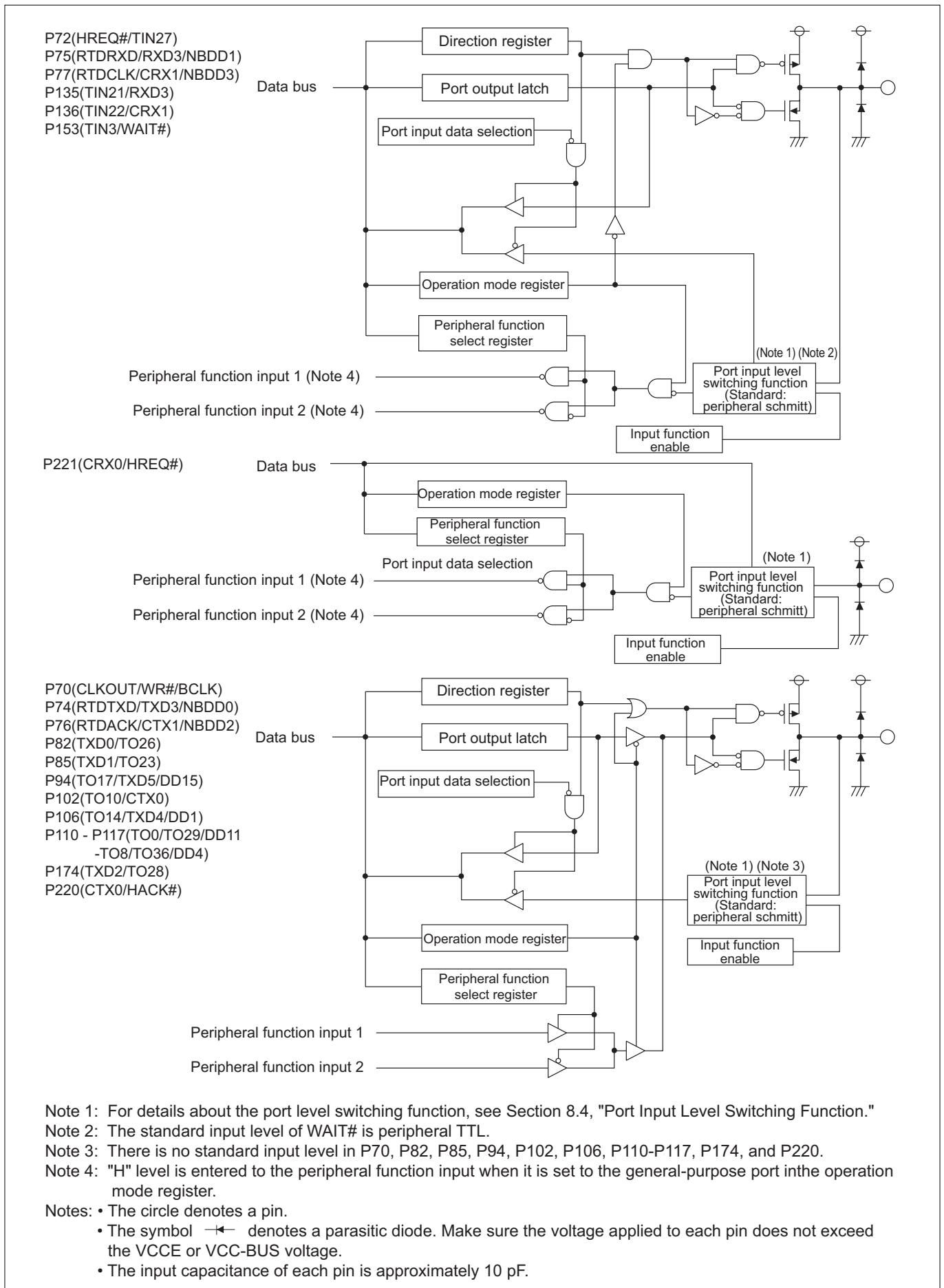


Figure 8.7.4 Port Peripheral Circuit Diagram (4)

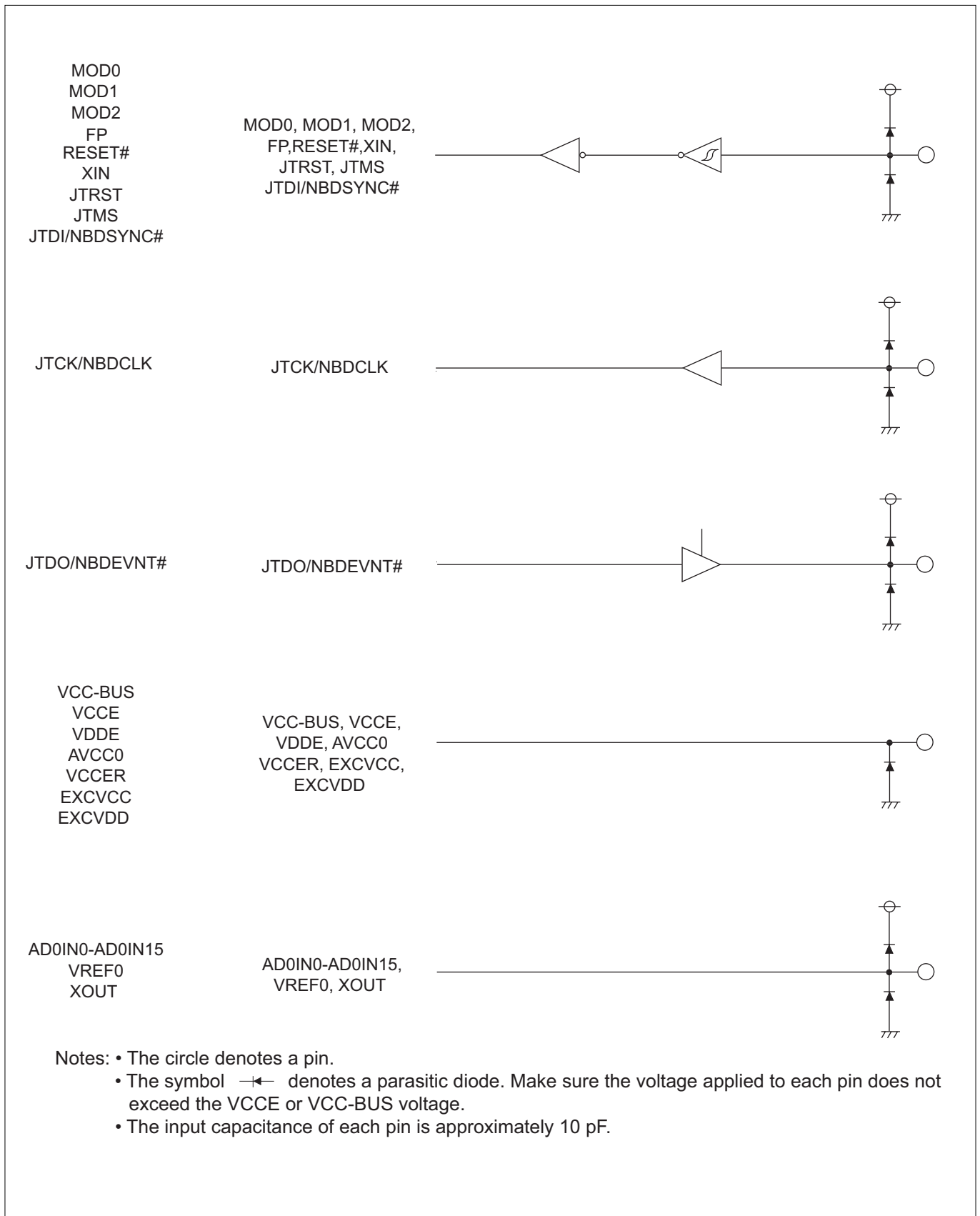


Figure 8.7.5 Port Peripheral Circuit Diagram (5)

## 8.8 Notes on Input/Output Ports

- **When using input/output ports in output mode**

Because the value of the Port Data Register is undefined when exiting the reset state, the Port Data Register must have its initial value set in it before the Port Direction Register can be set for output. Conversely, if the Port Direction Register is set for output before setting data in the Port Data Register, the Port Data Register outputs an undefined value until any data is written into it.

- **When using input/output ports in input mode**

After switching from output mode to input mode in the Port Direction Register, or after setting port input enable (PIEN0) bit to "1" (input enable), pin level can be read after 2BCLK period.

- **About the port input disable function**

Because the input/output ports are disabled against input upon exiting reset, they must be enabled for input by setting the Port Input Enable (PIEN0) bit to "1" before their input functions can be used.

When disabled against input, the input/output ports are in a state equivalent to a situation where the pin has a "L" level input applied. Consequently, if a peripheral input function (uncontrolled pin) is selected for any port while disabled against input by using the Port Operation Mode Register, the port may operate unexpectedly due to the "L" level input on it.

- **About the port peripheral function select register setting**

The Port Peripheral Function Select Register can only be set when the corresponding bit of the Port Operation Mode Register is "0."

- **About the peripheral function input when it is set to the general-purpose port**

In the pin for both peripheral function input and general-purpose port, "H" level is entered to the peripheral function input when it is set to the general-purpose port in the operation mode register. Therefore, when "L" level is entered to the peripheral function input pin, edge signal is entered to the peripheral function input at manipulating operation mode register.

# CHAPTER 9

---

## DMAC

- 9.1 Outline of the DMAC
- 9.2 DMAC Related Registers
- 9.3 Functional Description of the DMAC
- 9.4 Notes on the DMAC

## 9.1 Outline of the DMAC

The microcomputer internally contains a 10-channel DMAC (Direction Memory Access Controller). It allows data to be transferred at high speed between internal peripheral I/Os, between internal RAM and internal peripheral I/O, or between internal RAMs, as initiated by a software trigger or requested from an internal peripheral I/O.

**Table 9.1.1 Outline of the DMAC**

Item	Description
Number of channels	10 channels
Transfer request sources	<ul style="list-style-type: none"> <li>• Software trigger</li> <li>• Request from internal peripheral I/Os: A/D converter, multijunction timer, serial interface (reception completed, transmit buffer empty), CAN or DRI</li> <li>• DMA channels can be cascaded (Note 1)</li> </ul>
Maximum number of times transferred	65,536 times
Transferable address space (Note 2)	<ul style="list-style-type: none"> <li>• 32192 : 64 Kbytes x 3 banks (address space from H'0080 0000 to H'0082 FFFF)</li> <li>• 32195 : 48 Kbytes (address space from H'0080 0000 to H'0080 BFFF)</li> <li>• 32196 : 64 Kbytes + 16 byte (address space from H'0080 0000 to H'0081 3FFF)</li> <li>• Transfers between internal peripheral I/Os, between internal RAM and internal peripheral I/O, and between internal RAMs are supported.</li> </ul>
Transfer data size	16 or 8 bits
Transfer method	Single transfer DMA (control of the internal bus is relinquished for each transfer performed), dual-address transfer
Transfer mode	Single transfer mode
Direction of transfer	One of three modes can be selected for the source and destination: <ul style="list-style-type: none"> <li>• Address fixed</li> <li>• Address incremental</li> <li>• Ring buffered (can be selected from 32, 16, 8, 4 or 2 times)</li> </ul>
Channel priority	DMA0 > DMA1 > DMA2 > DMA3 > DMA4 > DMA5 > DMA6 > DMA7 > DMA8 > DMA9 (Priority is fixed)
Maximum transfer rate	26.6 Mbytes per second (when internal peripheral clock BCLK = 40 MHz)
Interrupt request	Group interrupt request can be generated when each transfer count register underflows.
Transfer area (Note 2)	32192 : 64 Kbytes x 3 banks of H'0080 0000 to H'0082 FFFF 32195 : 48 Kbytes of H'0080 0000 to H'0080 BFFF 32196 : 64 Kbytes + 16 byte of H'0080 0000 to H'0081 3FFF (Transferable in the entire RAM/SFR area)

Note 1: The DMA channels can be cascaded in the manner described below.

- Start DMA transfer on DMA1 upon completion of one DMA transfer on DMA0
- Start DMA transfer on DMA5 upon completion of all DMA transfers on DMA0 (upon underflow of the transfer count register)
- Start DMA transfer on DMA2 upon completion of one DMA transfer on DMA1
- Start DMA transfer on DMA0 upon completion of one DMA transfer on DMA2
- Start DMA transfer on DMA3 upon completion of one DMA transfer on DMA2
- Start DMA transfer on DMA4 upon completion of one DMA transfer on DMA3
- Start DMA transfer on DMA6 upon completion of one DMA transfer on DMA5
- Start DMA transfer on DMA7 upon completion of one DMA transfer on DMA6
- Start DMA transfer on DMA5 upon completion of one DMA transfer on DMA7
- Start DMA transfer on DMA8 upon completion of one DMA transfer on DMA7
- Start DMA transfer on DMA9 upon completion of one DMA transfer on DMA8

Note 2: The source address and destination address cannot go over the bank, which can be only transferred to the same bank or another one from a certain bank.



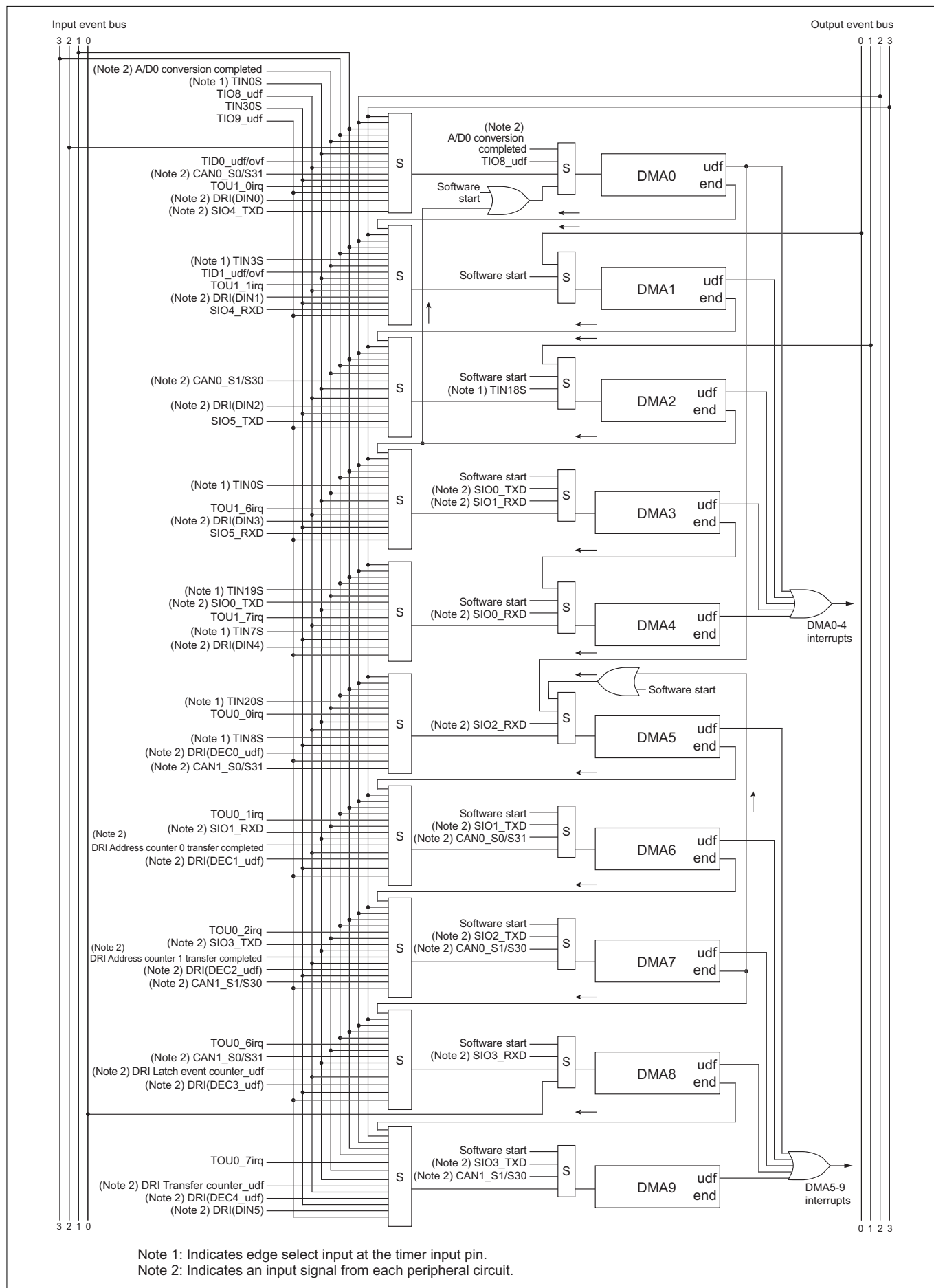


Figure 9.1.1 Block Diagram of the DMAC

## 9.2 DMAC Related Registers

The diagram below shows a memory map of the DMAC related registers.

DMAC Related Register Map (1/2)

Address	+0 address	+1 address	See pages
	b0	b7 b8	b15
H'0080 0400	DMA0–4 Interrupt Request Status Register (DM04ITST)	DMA0–4 Interrupt Request Mask Register (DM04ITMK)	9-35 9-36
	(Use inhibited area)		
H'0080 0408	DMA5–9 Interrupt Request Status Register (DM59ITST)	DMA5–9 Interrupt Request Mask Register (DM59ITMK)	9-35 9-36
	(Use inhibited area)		
H'0080 0410	DMA0 Channel Control Register 0 (DM0CNT0)	DMA0 Channel Control Register 1 (DM0CNT1)	9-6 9-7
H'0080 0412	DMA0 Source Address Register (DM0SA)		9-30
H'0080 0414	DMA0 Destination Address Register (DM0DA)		9-31
H'0080 0416	DMA0 Transfer Count Register (DM0TCT)		9-32
H'0080 0418	DMA5 Channel Control Register 0 (DM5CNT0)	DMA5 Channel Control Register 1 (DM5CNT1)	9-16 9-17
H'0080 041A	DMA5 Source Address Register (DM5SA)		9-30
H'0080 041C	DMA5 Destination Address Register (DM5DA)		9-31
H'0080 041E	DMA5 Transfer Count Register (DM5TCT)		9-32
H'0080 0420	DMA1 Channel Control Register 0 (DM1CNT0)	DMA1 Channel Control Register 1 (DM1CNT1)	9-8 9-9
H'0080 0422	DMA1 Source Address Register (DM1SA)		9-30
H'0080 0424	DMA1 Destination Address Register (DM1DA)		9-31
H'0080 0426	DMA1 Transfer Count Register (DM1TCT)		9-32
H'0080 0428	DMA6 Channel Control Register 0 (DM6CNT0)	DMA6 Channel Control Register 1 (DM6CNT1)	9-18 9-19
H'0080 042A	DMA6 Source Address Register (DM6SA)		9-30
H'0080 042C	DMA6 Destination Address Register (DM6DA)		9-31
H'0080 042E	DMA6 Transfer Count Register (DM6TCT)		9-32
H'0080 0430	DMA2 Channel Control Register 0 (DM2CNT0)	DMA2 Channel Control Register 1 (DM2CNT1)	9-10 9-11
H'0080 0432	DMA2 Source Address Register (DM2SA)		9-30
H'0080 0434	DMA2 Destination Address Register (DM2DA)		9-31
H'0080 0436	DMA2 Transfer Count Register (DM2TCT)		9-32
H'0080 0438	DMA7 Channel Control Register 0 (DM7CNT0)	DMA7 Channel Control Register 1 (DM7CNT1)	9-20 9-21
H'0080 043A	DMA7 Source Address Register (DM7SA)		9-30
H'0080 043C	DMA7 Destination Address Register (DM7DA)		9-31
H'0080 043E	DMA7 Transfer Count Register (DM7TCT)		9-32
H'0080 0440	DMA3 Channel Control Register 0 (DM3CNT0)	DMA3 Channel Control Register 1 (DM3CNT1)	9-12 9-13
H'0080 0442	DMA3 Source Address Register (DM3SA)		9-30
H'0080 0444	DMA3 Destination Address Register (DM3DA)		9-31
H'0080 0446	DMA3 Transfer Count Register (DM3TCT)		9-32

## DMAC Related Register Map (2/2)

Address	+0 address		+1 address		See pages
	b0	b7	b8	b15	
H'0080 0448	DMA8 Channel Control Register 0 (DM8CNT0)		DMA8 Channel Control Register 1 (DM8CNT1)		9-22 9-23
H'0080 044A	DMA8 Source Address Register (DM8SA)				9-30
H'0080 044C	DMA8 Destination Address Register (DM8DA)				9-31
H'0080 044E	DMA8 Transfer Count Register (DM8TCT)				9-32
H'0080 0450	DMA4 Channel Control Register 0 (DM4CNT0)		DMA4 Channel Control Register 1 (DM4CNT1)		9-14 9-15
H'0080 0452	DMA4 Source Address Register (DM4SA)				9-30
H'0080 0454	DMA4 Destination Address Register (DM4DA)				9-31
H'0080 0456	DMA4 Transfer Count Register (DM4TCT)				9-32
H'0080 0458	DMA9 Channel Control Register 0 (DM9CNT0)		DMA9 Channel Control Register 1 (DM9CNT1)		9-24 9-25
H'0080 045A	DMA9 Source Address Register (DM9SA)				9-30
H'0080 045C	DMA9 Destination Address Register (DM9DA)				9-31
H'0080 045E	DMA9 Transfer Count Register (DM9TCT)				9-32
H'0080 0460	DMA0 Software Request Generation Register (DM0SRI)				9-29
H'0080 0462	DMA1 Software Request Generation Register (DM1SRI)				9-29
H'0080 0464	DMA2 Software Request Generation Register (DM2SRI)				9-29
H'0080 0466	DMA3 Software Request Generation Register (DM3SRI)				9-29
H'0080 0468	DMA4 Software Request Generation Register (DM4SRI)				9-29
	(Use inhibited area)				
H'0080 0470	DMA5 Software Request Generation Register (DM5SRI)				9-29
H'0080 0472	DMA6 Software Request Generation Register (DM6SRI)				9-29
H'0080 0474	DMA7 Software Request Generation Register (DM7SRI)				9-29
H'0080 0476	DMA8 Software Request Generation Register (DM8SRI)				9-29
H'0080 0478	DMA9 Software Request Generation Register (DM9SRI)				9-29
	(Use inhibited area)				
H'0080 0480	(Use inhibited area)		DMA0 Channel Control Register 2 (DM0CNT2)		9-26
H'0080 0482	(Use inhibited area)		DMA1 Channel Control Register 2 (DM1CNT2)		9-26
H'0080 0484	(Use inhibited area)		DMA2 Channel Control Register 2 (DM2CNT2)		9-26
H'0080 0486	(Use inhibited area)		DMA3 Channel Control Register 2 (DM3CNT2)		9-26
H'0080 0488	(Use inhibited area)		DMA4 Channel Control Register 2 (DM4CNT2)		9-26
	(Use inhibited area)				
H'0080 0490	(Use inhibited area)		DMA5 Channel Control Register 2 (DM5CNT2)		9-26
H'0080 0492	(Use inhibited area)		DMA6 Channel Control Register 2 (DM6CNT2)		9-26
H'0080 0494	(Use inhibited area)		DMA7 Channel Control Register 2 (DM7CNT2)		9-26
H'0080 0496	(Use inhibited area)		DMA8 Channel Control Register 2 (DM8CNT2)		9-26
H'0080 0498	(Use inhibited area)		DMA9 Channel Control Register 2 (DM9CNT2)		9-26

## 9.2.1 DMA Channel Control Registers

DMA0 Channel Control Register 0 (DM0CNT0)

&lt;Address: H'0080 0410&gt;

b0	1	2	3	4	5	6	b7
MDSELO	TREQF0	REQSLO		TENLO	TSZSLO	SADSLO	DADSLO
0	0	0	0	0	0	0	0

&lt;Upon exiting reset: H'00&gt;

b	Bit Name	Function	R	W
0	MDSELO DMA0 transfer mode select bit	0: Normal mode 1: Ring buffer mode	R	W
1	TREQF0 DMA0 transfer request flag bit	0: Transfer not requested 1: Transfer requested	R(Note 1)	
2, 3	REQSLO DMA0 transfer request source select bit	00: Software start or one DMA2 transfer completed 01: A/D0 conversion completed 10: MJT (TIO8_udf) 11: Extended DMA0 transfer request source select (DMA0 Channel Control Register 1)	R	W
4	TENLO DMA0 transfer enable bit	0: Disable transfer 1: Enable transfer	R	W
5	TSZSLO DMA0 transfer size select bit	0: 16 bits 1: 8 bits	R	W
6	SADSLO DMA0 source address direction select bit	0: Fixed 1: Increment	R	W
7	DADSLO DMA0 destination address direction select bit	0: Fixed 1: Increment	R	W

Note 1: Only writing "0" is effective. Writing "1" has no effect; the bit retains the value it had before the write.

DMA0 Channel Control Register 1 (DM0CNT1)

&lt;Address: H'0080 0411&gt;

b8	9	10	11	12	13	14	b15
SADBN0		DADBN0		REQESEL0			
0	0	0	0	0	0	0	0

&lt;Upon exiting reset: H'00&gt;

b	Bit Name	Function	R	W
8, 9	SADBN0 Source address bank select bit (Note 1)(Note 2)	00: Bank 0 (A14=0, A15=0) 01: Bank 1 (A14=0, A15=1) 10: Bank 2 (A14=1, A15=0) 11: Settings inhibited	R	W
10, 11	DADBN0 Destination address bank select bit (Note 1)(Note 2)	00: Bank 0 (A14=0, A15=0) 01: Bank 1 (A14=0, A15=1) 10: Bank 2 (A14=1, A15=0) 11: Settings inhibited	R	W
12–15	REQESEL0 Extended DMA0 transfer request source select bit	0000: MJT (input event bus 2) 0001: MJT (TID0_udf/ovf) 0010: CAN (CAN0_S0/S31) 0011: Common 1) MJT (input event bus 1) 0100: Common 2) MJT (input event bus 3) 0101: Common 3) MJT (output event bus 2) 0110: Common 4) MJT (output event bus 3) 0111: Common 5) AD0 conversion completed 1000: Common 6) MJT (TIN0S) 1001: Common 7) MJT (TIO8_udf) 1010: Common 8) MJT (TIN30S) 1011: Common 9) MJT (TIO9_udf) 1100: Common 10) Settings inhibited 1101: MJT (TOU1_0irq) 1110: DRI (DIN0) 1111: SIO4_TXD (transimit buffer empty)	R	W

Note 1: No transfer over the bank is possible. Even when the address is incremented at the breakpoint of the bank and the source/destination addresses go over the bank, the source address bank select/destination address bank select bits are not incremented, and the bank head corresponds to the source address/destination address.

Note 2: Because Bank2 does not exist in the 32196, setting Bank2(A14=1, A15=0) is prohibited. Also, because Bank1 and Bank2 do not exist in the 32195, setting Bank1(A14=0, A15=1), and Bank2(A14=1, A15=0) is prohibited.

DMA1 Channel Control Register 0 (DM1CNT0)

&lt;Address: H'0080 0420&gt;

b0	1	2	3	4	5	6	b7
MDSEL1	TREQF1	REQSL1		TENL1	TSZSL1	SADSL1	DADSL1
0	0	0	0	0	0	0	0

&lt;Upon exiting reset: H'00&gt;

b	Bit Name	Function	R	W
0	MDSEL1 DMA1 transfer mode select bit	0: Normal mode 1: Ring buffer mode	R	W
1	TREQF1 DMA1 transfer request flag bit	0: Transfer not requested 1: Transfer requested	R(Note 1)	
2, 3	REQSL1 DMA1 transfer request source select bit	00: Software start 01: MJT (output event bus 0) 10: Settings inhibited 11: Extended DMA1 transfer request source select (DMA1 Channel Control Register 1)	R	W
4	TENL1 DMA1 transfer enable bit	0: Disable transfer 1: Enable transfer	R	W
5	TSZSL1 DMA1 transfer size select bit	0: 16 bits 1: 8 bits	R	W
6	SADSL1 DMA1 source address direction select bit	0: Fixed 1: Increment	R	W
7	DADSL1 DMA1 destination address direction select bit	0: Fixed 1: Increment	R	W

Note 1: Only writing "0" is effective. Writing "1" has no effect; the bit retains the value it had before the write.

DMA1 Channel Control Register 1 (DM1CNT1)

&lt;Address: H'0080 0421&gt;

b8	9	10	11	12	13	14	b15
SADBN1		DADBN1		REQESEL1			
0	0	0	0	0	0	0	0

&lt;Upon exiting reset: H'00&gt;

b	Bit Name	Function	R	W
8, 9	SADBN1 Source address bank select bit (Note 1)(Note 2)	00: Bank 0 (A14=0, A15=0) 01: Bank 1 (A14=0, A15=1) 10: Bank 2 (A14=1, A15=0) 11: Settings inhibited	R	W
10, 11	DADBN1 Destination address bank select bit (Note 1)(Note 2)	00: Bank 0 (A14=0, A15=0) 01: Bank 1 (A14=0, A15=1) 10: Bank 2 (A14=1, A15=0) 11: Settings inhibited	R	W
12–15	REQESEL1 Extended DMA1 transfer request source select bit	0000: One DMA0 transfer completed 0001: MJT(TIN3S) 0010: MJT(TID1_udf/ovf) 0011: Common 1) MJT (input event bus 1) 0100: Common 2) MJT (input event bus 3) 0101: Common 3) MJT (output event bus 2) 0110: Common 4) MJT (output event bus 3) 0111: Common 5) AD0 conversion completed 1000: Common 6) MJT (TIN0S) 1001: Common 7) MJT (TIO8_udf) 1010: Common 8) MJT (TIN30S) 1011: Common 9) MJT (TIO9_udf) 1100: Common 10) Settings inhibited 1101: MJT (TOU1_1irq) 1110: DRI (DIN1) 1111: SIO4_RXD (reception completed)	R	W

Note 1: No transfer over the bank is possible. Even when the address is incremented at the breakpoint of the bank and the source/destination addresses go over the bank, the source address bank select/destination address bank select bits are not incremented, and the bank head corresponds to the source address/destination address.

Note 2: Because Bank2 does not exist in the 32196, setting Bank2(A14=1, A15=0) is prohibited. Also, because Bank1 and Bank2 do not exist in the 32195, setting Bank1(A14=0, A15=1), and Bank2(A14=1, A15=0) is prohibited.

DMA2 Channel Control Register 0 (DM2CNT0)

&lt;Address: H'0080 0430&gt;

b0	1	2	3	4	5	6	b7
MDSEL2	TREQF2	REQSL2		TENL2	TSZSL2	SADSL2	DADSL2
0	0	0	0	0	0	0	0

&lt;Upon exiting reset: H'00&gt;

b	Bit Name	Function	R	W
0	MDSEL2 DMA2 transfer mode select bit	0: Normal mode 1: Ring buffer mode	R	W
1	TREQF2 DMA2 transfer request flag bit	0: Transfer not requested 1: Transfer requested	R(Note 1)	
2, 3	REQSL2 DMA2 transfer request source select bit	00: Software start 01: MJT (output event bus 1) 10: MJT (TIN18S) 11: Extended DMA2 transfer request source select (DMA2 Channel Control Register 1)	R	W
4	TENL2 DMA2 transfer enable bit	0: Disable transfer 1: Enable transfer	R	W
5	TSZSL2 DMA2 transfer size select bit	0: 16 bits 1: 8 bits	R	W
6	SADSL2 DMA2 source address direction select bit	0: Fixed 1: Increment	R	W
7	DADSL2 DMA2 destination address direction select bit	0: Fixed 1: Increment	R	W

Note 1: Only writing "0" is effective. Writing "1" has no effect; the bit retains the value it had before the write.



DMA2 Channel Control Register 1 (DM2CNT1)

&lt;Address: H'0080 0431&gt;

b8	9	10	11	12	13	14	b15
SADBN2		DADBN2		REQESEL2			
0	0	0	0	0	0	0	0

&lt;Upon exiting reset: H'00&gt;

b	Bit Name	Function	R	W
8, 9	SADBN2 Source address bank select bit (Note 1)(Note 2)	00: Bank 0 (A14=0, A15=0) 01: Bank 1 (A14=0, A15=1) 10: Bank 2 (A14=1, A15=0) 11: Settings inhibited	R	W
10, 11	DADBN2 Destination address bank select bit (Note 1)(Note 2)	00: Bank 0 (A14=0, A15=0) 01: Bank 1 (A14=0, A15=1) 10: Bank 2 (A14=1, A15=0) 11: Settings inhibited	R	W
12–15	REQESEL2 Extended DMA2 transfer request source select bit	0000: One DMA1 transfer completed 0001: Settings inhibited 0010: CAN(CAN0_S1/S30) 0011: Common 1) MJT (input event bus 1) 0100: Common 2) MJT (input event bus 3) 0101: Common 3) MJT (output event bus 2) 0110: Common 4) MJT (output event bus 3) 0111: Common 5) AD0 conversion completed 1000: Common 6) MJT (TIN0S) 1001: Common 7) MJT (TIO8_udf) 1010: Common 8) MJT (TIN30S) 1011: Common 9) MJT (TIO9_udf) 1100: Common 10) Settings inhibited 1101: Settings inhibited 1110: DRI (DIN2) 1111: SIO5_TXD (transmit buffer empty)	R	W

Note 1: No transfer over the bank is possible. Even when the address is incremented at the breakpoint of the bank and the source/destination addresses go over the bank, the source address bank select/destination address bank select bits are not incremented, and the bank head corresponds to the source address/destination address.

Note 2: Because Bank2 does not exist in the 32196, setting Bank2(A14=1, A15=0) is prohibited. Also, because Bank1 and Bank2 do not exist in the 32195, setting Bank1(A14=0, A15=1), and Bank2(A14=1, A15=0) is prohibited.

DMA3 Channel Control Register 0 (DM3CNT0)

&lt;Address: H'0080 0440&gt;

b0	1	2	3	4	5	6	b7
MDSEL3	TREQF3	REQSL3		TENL3	TSZSL3	SADSL3	DADSL3
0	0	0	0	0	0	0	0

&lt;Upon exiting reset: H'00&gt;

b	Bit Name	Function	R	W
0	MDSEL3 DMA3 transfer mode select bit	0: Normal mode 1: Ring buffer mode	R	W
1	TREQF3 DMA3 transfer request flag bit	0: Transfer not requested 1: Transfer requested	R(Note 1)	
2, 3	REQSL3 DMA3 transfer request source select bit	00: Software start 01: SIO0_TXD (transmit buffer empty) 10: SIO1_RXD (reception completed) 11: Extended DMA3 transfer request source select (DMA3 Channel Control Register 1)	R	W
4	TENL3 DMA3 transfer enable bit	0: Disable transfer 1: Enable transfer	R	W
5	TSZSL3 DMA3 transfer size select bit	0: 16 bits 1: 8 bits	R	W
6	SADSL3 DMA3 source address direction select bit	0: Fixed 1: Increment	R	W
7	DADSL3 DMA3 destination address direction select bit	0: Fixed 1: Increment	R	W

Note 1: Only writing "0" is effective. Writing "1" has no effect; the bit retains the value it had before the write.

DMA3 Channel Control Register 1 (DM3CNT1)

&lt;Address: H'0080 0441&gt;

b8	9	10	11	12	13	14	b15
SADBN3		DADBN3		REQESEL3			
0	0	0	0	0	0	0	0

&lt;Upon exiting reset: H'00&gt;

b	Bit Name	Function	R	W
8, 9	SADBN3 Source address bank select bit (Note 1)(Note 2)	00: Bank 0 (A14=0, A15=0) 01: Bank 1 (A14=0, A15=1) 10: Bank 2 (A14=1, A15=0) 11: Settings inhibited	R	W
10, 11	DADBN3 Destination address bank select bit (Note 1)(Note 2)	00: Bank 0 (A14=0, A15=0) 01: Bank 1 (A14=0, A15=1) 10: Bank 2 (A14=1, A15=0) 11: Settings inhibited	R	W
12–15	REQESEL3 Extended DMA3 transfer request source select bit	0000: MJT(TIN0S) 0001: One DMA2 transfer completed 0010: Settings inhibited 0011: Common 1) MJT (input event bus 1) 0100: Common 2) MJT (input event bus 3) 0101: Common 3) MJT (output event bus 2) 0110: Common 4) MJT (output event bus 3) 0111: Common 5) AD0 conversion completed 1000: Common 6) MJT (TIN0S) 1001: Common 7) MJT (TIO8_udf) 1010: Common 8) MJT (TIN30S) 1011: Common 9) MJT (TIO9_udf) 1100: Common 10) Settings inhibited 1101: MJT (TOU1_6irq) 1110: DRI (DIN3) 1111: SIO5_RXD (reception completed)	R	W

Note 1: No transfer over the bank is possible. Even when the address is incremented at the breakpoint of the bank and the source/destination addresses go over the bank, the source address bank select/destination address bank select bits are not incremented, and the bank head corresponds to the source address/destination address.

Note 2: Because Bank2 does not exist in the 32196, setting Bank2(A14=1, A15=0) is prohibited. Also, because Bank1 and Bank2 do not exist in the 32195, setting Bank1(A14=0, A15=1), and Bank2(A14=1, A15=0) is prohibited.

DMA4 Channel Control Register 0 (DM4CNT0)

&lt;Address: H'0080 0450&gt;

b0	1	2	3	4	5	6	b7
MDSEL4	TREQF4	REQSL4		TENL4	TSZSL4	SADSL4	DADSL4
0	0	0	0	0	0	0	0

&lt;Upon exiting reset: H'00&gt;

b	Bit Name	Function	R	W
0	MDSEL4 DMA4 transfer mode select bit	0: Normal mode 1: Ring buffer mode	R	W
1	TREQF4 DMA4 transfer request flag bit	0: Transfer not requested 1: Transfer requested	R(Note 1)	
2, 3	REQSL4 DMA4 transfer request source select bit	00: Software start 01: One DMA3 transfer completed 10: SIO0_RXD (reception completed) 11: Extended DMA4 transfer request source select (DMA4 Channel Control Register 1)	R	W
4	TENL4 DMA4 transfer enable bit	0: Disable transfer 1: Enable transfer	R	W
5	TSZSL4 DMA4 transfer size select bit	0: 16 bits 1: 8 bits	R	W
6	SADSL4 DMA4 source address direction select bit	0: Fixed 1: Increment	R	W
7	DADSL4 DMA4 destination address direction select bit	0: Fixed 1: Increment	R	W

Note 1: Only writing "0" is effective. Writing "1" has no effect; the bit retains the value it had before the write.

DMA4 Channel Control Register 1 (DM4CNT1)

&lt;Address: H'0080 0451&gt;

b8	9	10	11	12	13	14	b15
SADBN4		DADBN4		REQESEL4			
0	0	0	0	0	0	0	0

&lt;Upon exiting reset: H'00&gt;

b	Bit Name	Function	R	W
8, 9	SADBN4 Source address bank select bit (Note 1)(Note 2)	00: Bank 0 (A14=0, A15=0) 01: Bank 1 (A14=0, A15=1) 10: Bank 2 (A14=1, A15=0) 11: Settings inhibited	R	W
10, 11	DADBN4 Destination address bank select bit (Note 1)(Note 2)	00: Bank 0 (A14=0, A15=0) 01: Bank 1 (A14=0, A15=1) 10: Bank 2 (A14=1, A15=0) 11: Settings inhibited	R	W
12–15	REQESEL4 Extended DMA4 transfer request source select bit	0000: MJT(TIN19S) 0001: SIO0_TXD (transmit buffer empty) 0010: MJT(TOU1_7irq) 0011: Common 1) MJT (input event bus 1) 0100: Common 2) MJT (input event bus 3) 0101: Common 3) MJT (output event bus 2) 0110: Common 4) MJT (output event bus 3) 0111: Common 5) AD0 conversion completed 1000: Common 6) MJT (TIN0S) 1001: Common 7) MJT (TIO8_udf) 1010: Common 8) MJT (TIN30S) 1011: Common 9) MJT (TIO9_udf) 1100: Common 10) Settings inhibited 1101: MJT (TIN7S) 1110: DRI (DIN4) 1111: Settings inhibited	R	W

Note 1: No transfer over the bank is possible. Even when the address is incremented at the breakpoint of the bank and the source/destination addresses go over the bank, the source address bank select/destination address bank select bits are not incremented, and the bank head corresponds to the source address/destination address.

Note 2: Because Bank2 does not exist in the 32196, setting Bank2(A14=1, A15=0) is prohibited. Also, because Bank1 and Bank2 do not exist in the 32195, setting Bank1(A14=0, A15=1), and Bank2(A14=1, A15=0) is prohibited.

DMA5 Channel Control Register 0 (DM5CNT0)

&lt;Address: H'0080 0418&gt;

b0	1	2	3	4	5	6	b7
MDSEL5	TREQF5	REQSL5		TENL5	TSZSL5	SADSL5	DADSL5
0	0	0	0	0	0	0	0

&lt;Upon exiting reset: H'00&gt;

b	Bit Name	Function	R	W
0	MDSEL5 DMA5 transfer mode select bit	0: Normal mode 1: Ring buffer mode	R	W
1	TREQF5 DMA5 transfer request flag bit	0: Transfer not requested 1: Transfer requested	R(Note 1)	
2, 3	REQSL5 DMA5 transfer request source select bit	00: Software start or one DMA7 transfer completed 01: All DMA0 transfers completed 10: SIO2_RXD (reception completed) 11: Extended DMA5 transfer request source select (DMA5 Channel Control Register 1)	R	W
4	TENL5 DMA5 transfer enable bit	0: Disable transfer 1: Enable transfer	R	W
5	TSZSL5 DMA5 transfer size select bit	0: 16 bits 1: 8 bits	R	W
6	SADSL5 DMA5 source address direction select bit	0: Fixed 1: Increment	R	W
7	DADSL5 DMA5 destination address direction select bit	0: Fixed 1: Increment	R	W

Note 1: Only writing "0" is effective. Writing "1" has no effect; the bit retains the value it had before the write.

DMA5 Channel Control Register 1 (DM5CNT1)

&lt;Address: H'0080 0419&gt;

b8	9	10	11	12	13	14	b15
SADBN5		DADBN5		REQESEL5			
0	0	0	0	0	0	0	0

&lt;Upon exiting reset: H'00&gt;

b	Bit Name	Function	R	W
8, 9	SADBN5 Source address bank select bit (Note 1)(Note 2)	00: Bank 0 (A14=0, A15=0) 01: Bank 1 (A14=0, A15=1) 10: Bank 2 (A14=1, A15=0) 11: Settings inhibited	R	W
10, 11	DADBN5 Destination address bank select bit (Note 1)(Note 2)	00: Bank 0 (A14=0, A15=0) 01: Bank 1 (A14=0, A15=1) 10: Bank 2 (A14=1, A15=0) 11: Settings inhibited	R	W
12–15	REQESEL5 Extended DMA5 transfer request source select bit	0000: MJT(TIN20S) 0001: MJT(TOU0_0irq) 0010: Settings inhibited 0011: Common 1) MJT (input event bus 1) 0100: Common 2) MJT (input event bus 3) 0101: Common 3) MJT (output event bus 2) 0110: Common 4) MJT (output event bus 3) 0111: Common 5) AD0 conversion completed 1000: Common 6) MJT (TIN0S) 1001: Common 7) MJT (TIO8_udf) 1010: Common 8) MJT (TIN30S) 1011: Common 9) MJT (TIO9_udf) 1100: Common 10) Settings inhibited 1101: MJT (TIN8S) 1110: DRI (DEC0_udf) 1111: CAN1_S0/S31	R	W

Note 1: No transfer over the bank is possible. Even when the address is incremented at the breakpoint of the bank and the source/destination addresses go over the bank, the source address bank select/destination address bank select bits are not incremented, and the bank head corresponds to the source address/destination address.

Note 2: Because Bank2 does not exist in the 32196, setting Bank2(A14=1, A15=0) is prohibited. Also, because Bank1 and Bank2 do not exist in the 32195, setting Bank1(A14=0, A15=1), and Bank2(A14=1, A15=0) is prohibited.

DMA6 Channel Control Register 0 (DM6CNT0)

&lt;Address: H'0080 0428&gt;

b0	1	2	3	4	5	6	b7
MDSEL6	TREQF6	REQSL6		TENL6	TSZSL6	SADSL6	DADSL6
0	0	0	0	0	0	0	0

&lt;Upon exiting reset: H'00&gt;

b	Bit Name	Function	R	W
0	MDSEL6 DMA6 transfer mode select bit	0: Normal mode 1: Ring buffer mode	R	W
1	TREQF6 DMA6 transfer request flag bit	0: Transfer not requested 1: Transfer requested	R(Note 1)	
2, 3	REQSL6 DMA6 transfer request source select bit	00: Software start 01: SIO1_TXD (transmit buffer empty) 10: CAN0_S0/S31 11: Extended DMA6 transfer request source select (DMA6 Channel Control Register 1)	R	W
4	TENL6 DMA6 transfer enable bit	0: Disable transfer 1: Enable transfer	R	W
5	TSZSL6 DMA6 transfer size select bit	0: 16 bits 1: 8 bits	R	W
6	SADSL6 DMA6 source address direction select bit	0: Fixed 1: Increment	R	W
7	DADSL6 DMA6 destination address direction select bit	0: Fixed 1: Increment	R	W

Note 1: Only writing "0" is effective. Writing "1" has no effect; the bit retains the value it had before the write.



DMA6 Channel Control Register 1 (DM6CNT1)

&lt;Address: H'0080 0429&gt;

b8	9	10	11	12	13	14	b15
SADBN6		DADBN6		REQESEL6			
0	0	0	0	0	0	0	0

&lt;Upon exiting reset: H'00&gt;

b	Bit Name	Function	R	W
8, 9	SADBN6 Source address bank select bit (Note 1)(Note 2)	00: Bank 0 (A14=0, A15=0) 01: Bank 1 (A14=0, A15=1) 10: Bank 2 (A14=1, A15=0) 11: Settings inhibited	R	W
10, 11	DADBN6 Destination address bank select bit (Note 1)(Note 2)	00: Bank 0 (A14=0, A15=0) 01: Bank 1 (A14=0, A15=1) 10: Bank 2 (A14=1, A15=0) 11: Settings inhibited	R	W
12–15	REQESEL6 Extended DMA6 transfer request source select bit	0000: One DMA5 transfer completed 0001: MJT(TOU0_1irq) 0010: SIO1_RXD (reception completed) 0011: Common 1) MJT (input event bus 1) 0100: Common 2) MJT (input event bus 3) 0101: Common 3) MJT (output event bus 2) 0110: Common 4) MJT (output event bus 3) 0111: Common 5) AD0 conversion completed 1000: Common 6) MJT (TIN0S) 1001: Common 7) MJT (TIO8_udf) 1010: Common 8) MJT (TIN30S) 1011: Common 9) MJT (TIO9_udf) 1100: Common 10) Settings inhibited 1101: DRI (address counter 0 transfer) 1110: DRI (DEC1_udf) 1111: Settings inhibited	R	W

Note 1: No transfer over the bank is possible. Even when the address is incremented at the breakpoint of the bank and the source/destination addresses go over the bank, the source address bank select/destination address bank select bits are not incremented, and the bank head corresponds to the source address/destination address.

Note 2: Because Bank2 does not exist in the 32196, setting Bank2(A14=1, A15=0) is prohibited. Also, because Bank1 and Bank2 do not exist in the 32195, setting Bank1(A14=0, A15=1), and Bank2(A14=1, A15=0) is prohibited.

DMA7 Channel Control Register 0 (DM7CNT0)

&lt;Address: H'0080 0438&gt;

b0	1	2	3	4	5	6	b7
MSEL7	TREQF7	REQSL7		TENL7	TSZSL7	SADSL7	DADSL7
0	0	0	0	0	0	0	0

&lt;Upon exiting reset: H'00&gt;

b	Bit Name	Function	R	W
0	MSEL7 DMA7 transfer mode select bit	0: Normal mode 1: Ring buffer mode	R	W
1	TREQF7 DMA7 transfer request flag bit	0: Transfer not requested 1: Transfer requested	R(Note 1)	
2, 3	REQSL7 DMA7 transfer request source select bit	00: Software start 01: SIO2_TXD (transmit buffer empty) 10: CAN0_S1/S30 11: Extended DMA7 transfer request source select (DMA7 Channel Control Register 1)	R	W
4	TENL7 DMA7 transfer enable bit	0: Disable transfer 1: Enable transfer	R	W
5	TSZSL7 DMA7 transfer size select bit	0: 16 bits 1: 8 bits	R	W
6	SADSL7 DMA7 source address direction select bit	0: Fixed 1: Increment	R	W
7	DADSL7 DMA7 destination address direction select bit	0: Fixed 1: Increment	R	W

Note 1: Only writing "0" is effective. Writing "1" has no effect; the bit retains the value it had before the write.

DMA7 Channel Control Register 1 (DM7CNT1)

&lt;Address: H'0080 0439&gt;

b8	9	10	11	12	13	14	b15
SADBN7		DADBN7		REQESEL7			
0	0	0	0	0	0	0	0

&lt;Upon exiting reset: H'00&gt;

b	Bit Name	Function	R	W
8, 9	SADBN7 Source address bank select bit (Note 1)(Note 2)	00: Bank 0 (A14=0, A15=0) 01: Bank 1 (A14=0, A15=1) 10: Bank 2 (A14=1, A15=0) 11: Settings inhibited	R	W
10, 11	DADBN7 Destination address bank select bit (Note 1)(Note 2)	00: Bank 0 (A14=0, A15=0) 01: Bank 1 (A14=0, A15=1) 10: Bank 2 (A14=1, A15=0) 11: Settings inhibited	R	W
12–15	REQESEL7 Extended DMA7 transfer request source select bit	0000: One DMA6 transfer completed 0001: MJT(TOU0_2irq) 0010: SIO3_TXD (transmit buffer empty) 0011: Common 1) MJT (input event bus 1) 0100: Common 2) MJT (input event bus 3) 0101: Common 3) MJT (output event bus 2) 0110: Common 4) MJT (output event bus 3) 0111: Common 5) AD0 conversion completed 1000: Common 6) MJT (TIN0S) 1001: Common 7) MJT (TIO8_udf) 1010: Common 8) MJT (TIN30S) 1011: Common 9) MJT (TIO9_udf) 1100: Common 10) Settings inhibited 1101: DRI (address counter 1 transfer) 1110: DRI (DEC2_udf) 1111: CAN1_S1/S30	R	W

Note 1: No transfer over the bank is possible. Even when the address is incremented at the breakpoint of the bank and the source/destination addresses go over the bank, the source address bank select/destination address bank select bits are not incremented, and the bank head corresponds to the source address/destination address.

Note 2: Because Bank2 does not exist in the 32196, setting Bank2(A14=1, A15=0) is prohibited. Also, because Bank1 and Bank2 do not exist in the 32195, setting Bank1(A14=0, A15=1), and Bank2(A14=1, A15=0) is prohibited.

DMA8 Channel Control Register 0 (DM8CNT0)

&lt;Address: H'0080 0448&gt;

b0	1	2	3	4	5	6	b7
MDSEL8	TREQF8	REQSL8		TENL8	TSZSL8	SADSL8	DADSL8
0	0	0	0	0	0	0	0

&lt;Upon exiting reset: H'00&gt;

b	Bit Name	Function	R	W
0	MDSEL8 DMA8 transfer mode select bit	0: Normal mode 1: Ring buffer mode	R	W
1	TREQF8 DMA8 transfer request flag bit	0: Transfer not requested 1: Transfer requested	R(Note 1)	
2, 3	REQSL8 DMA8 transfer request source select bit	00: Software start 01: MJT (input event bus 0) 10: SIO3_RXD (reception completed) 11: Extended DMA8 transfer request source selected (DMA8 Channel Control Register 1)	R	W
4	TENL8 DMA8 transfer enable bit	0: Disable transfer 1: Enable transfer	R	W
5	TSZSL8 DMA8 transfer size select bit	0: 16 bits 1: 8 bits	R	W
6	SADSL8 DMA8 source address direction select bit	0: Fixed 1: Increment	R	W
7	DADSL8 DMA8 destination address direction select bit	0: Fixed 1: Increment	R	W

Note 1: Only writing "0" is effective. Writing "1" has no effect; the bit retains the value it had before the write.

DMA8 Channel Control Register 1 (DM8CNT1)

&lt;Address: H'0080 0449&gt;

b8	9	10	11	12	13	14	b15
SADBN8		DADBN8		REQESEL8			
0	0	0	0	0	0	0	0

&lt;Upon exiting reset: H'00&gt;

b	Bit Name	Function	R	W
8, 9	SADBN8 Source address bank select bit (Note 1)(Note 2)	00: Bank 0 (A14=0, A15=0) 01: Bank 1 (A14=0, A15=1) 10: Bank 2 (A14=1, A15=0) 11: Settings inhibited	R	W
10, 11	DADBN8 Destination address bank select bit (Note 1)(Note 2)	00: Bank 0 (A14=0, A15=0) 01: Bank 1 (A14=0, A15=1) 10: Bank 2 (A14=1, A15=0) 11: Settings inhibited	R	W
12–15	REQESEL8 Extended DMA8 transfer request source select bit	0000: CAN1_S0/S31 0001: MJT(TOU0_6irq) 0010: One DMA7 transfer completed 0011: Common 1) MJT (input event bus 1) 0100: Common 2) MJT (input event bus 3) 0101: Common 3) MJT (output event bus 2) 0110: Common 4) MJT (output event bus 3) 0111: Common 5) AD0 conversion completed 1000: Common 6) MJT (TIN0S) 1001: Common 7) MJT (TIO8_udf) 1010: Common 8) MJT (TIN30S) 1011: Common 9) MJT (TIO9_udf) 1100: Common 10) Settings inhibited 1101: DRI (latch event counter_udf) 1110: DRI (DEC3_udf) 1111: Settings inhibited	R	W

Note 1: No transfer over the bank is possible. Even when the address is incremented at the breakpoint of the bank and the source/destination addresses go over the bank, the source address bank select/destination address bank select bits are not incremented, and the bank head corresponds to the source address/destination address.

Note 2: Because Bank2 does not exist in the 32196, setting Bank2(A14=1, A15=0) is prohibited. Also, because Bank1 and Bank2 do not exist in the 32195, setting Bank1(A14=0, A15=1), and Bank2(A14=1, A15=0) is prohibited.

DMA9 Channel Control Register 0 (DM9CNT0)

&lt;Address: H'0080 0458&gt;

b0	1	2	3	4	5	6	b7
MDSEL9	TREQF9	REQSL9		TENL9	TSZSL9	SADSL9	DADSL9
0	0	0	0	0	0	0	0

&lt;Upon exiting reset: H'00&gt;

b	Bit Name	Function	R	W
0	MDSEL9 DMA9 transfer mode select bit	0: Normal mode 1: Ring buffer mode	R	W
1	TREQF9 DMA9 transfer request flag bit	0: Transfer not requested 1: Transfer requested	R(Note 1)	
2, 3	REQSL9 DMA9 transfer request source select bit	00: Software start 01: SIO3_TXD (transmit buffer empty) 10: CAN1_S1/S30 11: Extended DMA9 transfer request source selected (DMA9 Channel Control Register 1)	R	W
4	TENL9 DMA9 transfer enable bit	0: Disable transfer 1: Enable transfer	R	W
5	TSZSL9 DMA9 transfer size select bit	0: 16 bits 1: 8 bits	R	W
6	SADSL9 DMA9 source address direction select bit	0: Fixed 1: Increment	R	W
7	DADSL9 DMA9 destination address direction select bit	0: Fixed 1: Increment	R	W

Note 1: Only writing "0" is effective. Writing "1" has no effect; the bit retains the value it had before the write.

DMA9 Channel Control Register 1 (DM9CNT1)

&lt;Address: H'0080 0459&gt;

b8	9	10	11	12	13	14	b15
SADBN9		DADBN9		REQESEL9			
0	0	0	0	0	0	0	0

&lt;Upon exiting reset: H'00&gt;

b	Bit Name	Function	R	W
8, 9	SADBN9 Source address bank select bit (Note 1)(Note 2)	00: Bank 0 (A14=0, A15=0) 01: Bank 1 (A14=0, A15=1) 10: Bank 2 (A14=1, A15=0) 11: Settings inhibited	R	W
10, 11	DADBN9 Destination address bank select bit (Note 1)(Note 2)	00: Bank 0 (A14=0, A15=0) 01: Bank 1 (A14=0, A15=1) 10: Bank 2 (A14=1, A15=0) 11: Settings inhibited	R	W
12–15	REQESEL9 Extended DMA9 transfer request source select bit	0000: One DMA8 transfer completed 0001: MJT(TOU0_7irq) 0010: Settings inhibited 0011: Common 1) MJT (input event bus 1) 0100: Common 2) MJT (input event bus 3) 0101: Common 3) MJT (output event bus 2) 0110: Common 4) MJT (output event bus 3) 0111: Common 5) AD0 conversion completed 1000: Common 6) MJT (TIN0S) 1001: Common 7) MJT (TIO8_udf) 1010: Common 8) MJT (TIN30S) 1011: Common 9) MJT (TIO9_udf) 1100: Common 10) Settings inhibited 1101: DRI (transfer counter_udf) 1110: DRI (DEC4_udf) 1111: DRI (DIN5)	R	W

Note 1: No transfer over the bank is possible. Even when the address is incremented at the breakpoint of the bank and the source/destination addresses go over the bank, the source address bank select/destination address bank select bits are not incremented, and the bank head corresponds to the source address/destination address.

Note 2: Because Bank2 does not exist in the 32196, setting Bank2(A14=1, A15=0) is prohibited. Also, because Bank1 and Bank2 do not exist in the 32195, setting Bank1(A14=0, A15=1), and Bank2(A14=1, A15=0) is prohibited.

DMA0 Channel Control Register 2 (DM0CNT2)	<Address: H'0080 0481>
DMA1 Channel Control Register 2 (DM1CNT2)	<Address: H'0080 0483>
DMA2 Channel Control Register 2 (DM2CNT2)	<Address: H'0080 0485>
DMA3 Channel Control Register 2 (DM3CNT2)	<Address: H'0080 0487>
DMA4 Channel Control Register 2 (DM4CNT2)	<Address: H'0080 0489>
DMA5 Channel Control Register 2 (DM5CNT2)	<Address: H'0080 0491>
DMA6 Channel Control Register 2 (DM6CNT2)	<Address: H'0080 0493>
DMA7 Channel Control Register 2 (DM7CNT2)	<Address: H'0080 0495>
DMA8 Channel Control Register 2 (DM8CNT2)	<Address: H'0080 0497>
DMA9 Channel Control Register 2 (DM9CNT2)	<Address: H'0080 0499>

b8	9	10	11	12	13	14	b15
SELFEN		RINGSEL					
0	0	0	0	0	0	0	0

&lt;Upon exiting reset: H'00&gt;

b	Bit Name	Function	R	W
8	SELFEN Self channel transfer selection	0: Disable self channel transfer 1: Enable self channel transfer	R	W
9	No function assigned. Fix to "0."		0	0
10–15	RINGSEL Ring buffer select bit	00 0000: 32-time ring buffer mode 10 0000: 32-time ring buffer mode 11 0000: 16-time ring buffer mode 11 1000: 8-time ring buffer mode 11 1100: 4-time ring buffer mode 11 1110: 2-time ring buffer mode Settings other than above are inhibited	R	W

The DMA Channel Control Register 0 consists of the bits to select DMA transfer mode on each channel, set the DMA transfer request flag, select the cause or source of DMA request and enable DMA transfer, as well as those to set the transfer size and the source/destination address directions.

The DMA Channel Control Register 1 consists of the bits to select a source/destination address bank and the cause or source of extended DMA transfer request on each DMA channel.

The DMA Channel Control Register 2 consists of the bits to enable self channel transfer on each channel and set the number of transfers in the ring buffer mode.



**[DMnCNT0 Register]****(1) MDSELn (DMA<sub>n</sub> Transfer Mode Select) bit (Bit 0)**

When performing DMA transfer in single transfer mode, this bit selects normal mode or ring buffer mode. Setting this bit to "0" selects normal mode and setting it to "1" selects ring buffer mode. The number of transfers in the ring buffer mode is selected with register DMnCNT2.

**(2) TREQFn (DMA<sub>n</sub> Transfer Request Flag) bit (Bit 1)**

This flag indicates if there are DMA transfer requests for each channel. This bit is set to "1," when DMA transfer requests are occurred in spite of TENLn bit setting value and then after completing transmission, it is cleared to "0."

And when write "0" to this bit, it clear DMA transfer requests occurred. When write "1," it keeps value which before writing.

If a new DMA transfer request occurs on a channel for which the DMA transfer request flag has already been set to "1," the next DMA transfer request is not accepted until the transfer being performed on that channel is completed.

**(3) REQSLn (DMA<sub>n</sub> Transfer Request Source Select) bits (Bits 2, 3)**

These bits select the cause or source of DMA transfer request on each DMA channel.

**(4) TENLn (DMA<sub>n</sub> Transfer Enable) bit (Bit 4)**

When setting this bit to "1" (enable transfer), DMA transfer is enable and when all transmissions are completed (underflow of transfer count register), it is cleared to "0." And when DMA transfer request is already occurred and set to transfer enable, DMA transfer starts immediately so that make sure not to do that.

When setting this bit to "0" (disable transfer), DMA transfer is disable. However, if a transfer request has already been accepted, transfers on that channel are not disabled until after the requested transfer is completed.

**(5) TSZSLn (DMA<sub>n</sub> Transfer Size Select) bit (Bit 5)**

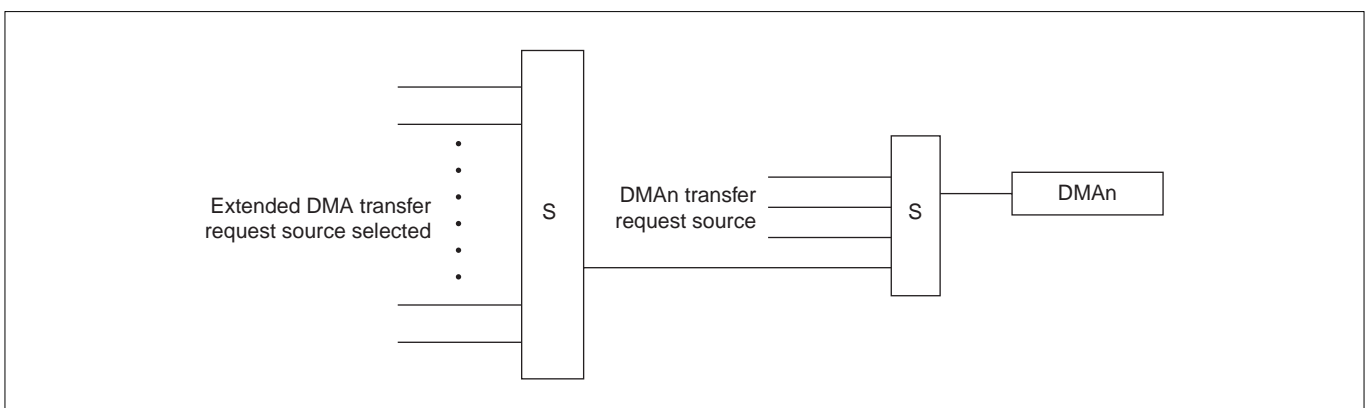
This bit selects the number of bits to be transferred in one DMA transfer operation (the unit of one transfer). The unit of one transfer is 16 bits when TSZSL = "0" or 8 bits when TSZSL = "1."

**(6) SADSLn (DMA<sub>n</sub> Source Address Direction Select) bit (Bit 6)**

This bit selects the direction in which the source address changes. This mode can be selected from two choices: Address fixed or Address incremental.

**(7) DADSLn (DMA<sub>n</sub> Destination Address Direction Select) bit (Bit 7)**

This bit selects the direction in which the destination address changes. This mode can be selected from two choices: Address fixed or Address incremental.



**Figure 9.2.1 Block Diagram of Extended DMA Transfer Request Source Selection**

**[DMnCNT1 Register]****(1) SADBnX (DMA<sub>n</sub> Source Address Bank Select) bits (Bits 8, 9)**

These bits select a source address bank to be used from among Bank 0, Bank 1 and Bank 2. But no bank exists in 32196, setting Bank2(A14=1, A15=0) is prohibited. Because Bank1 and Bank2 do not exist in the 32195, setting Bank1 and Bank2 is prohibited. And also no transfer over the bank is carried out. Upon completion of bank transfer to the final address, the bank is then to be transferred to the head address.

**(2) DADBnX (DMA<sub>n</sub> Destination Address Bank Select) bits (Bits 10, 11)**

These bits select a destination address bank to be used from among Bank 0, Bank 1 and Bank 2. But no bank exists in 32196, setting Bank2(A14=1, A15=0) is prohibited. Because Bank1 and Bank2 do not exist in the 32195, setting Bank1 and Bank2 is prohibited. And also no transfer over the bank is carried out. Upon completion of bank transfer to the final address, the bank is then to be transferred to the head address.

**(3) REQSEL<sub>n</sub> (Extended DMA<sub>n</sub> Transfer Request Source Select) bits (Bits 12–15)**

These bits select the cause or source of extended DMA transfer request on each DMA channel.

Note: • The extended DMA transfer request sources selected by the REQSEL<sub>n</sub> (Extended DMA<sub>n</sub> Transfer Request Source Select) bits have no effect unless the “Extended” DMA transfer request source is selected with the DMA Channel Control Register’s DMA Request Source Select (REQSL<sub>n</sub>) bits.

**[DMnCNT2 Register]****(1) SELFEN (DMA<sub>n</sub> Self Channel Transfer Select ) bit (Bit 8)**

Clearing this bit to “0” disables self channel transfer, and setting it to “1” enables self channel transfer. In case where self channel transfer was allowed, the DMA transfer request occurs for the self channel each time single DMA transfer is completed if the initial transfer request arises, and DMA transfer is carried out until all transfers are completed (transfer count register underflow).

However the control of internal bus is relinquished each time single DMA transfer is completed.

And if set DMA transfer n times, DMA transfer request is occurred for its channel after completing all DMA transfer, so that it is necessary to pay attention of clearing DMA transfer request or so on when DMA transfer is started again.

**(2) RINGSEL (DMA<sub>n</sub> Ring Buffer Select) bit (Bits 10–15)**

These bits select the number of DMA transfers to each channel in the ring buffer mode from among 32, 16, 8, 4 and 2 times.

In the ring buffer mode, after transfer from the transfer start address, the bit returns to the transfer start address again, and the same operation is repeated by the number of transfers thus selected. In the ring buffer mode, the transfer count register is placed in the free run mode, and transfer operation is continued until the transfer enable bit is cleared to “0” (transfer disable).

Also, the DMA transfer-completed interrupt request does not arise during ring buffer mode.

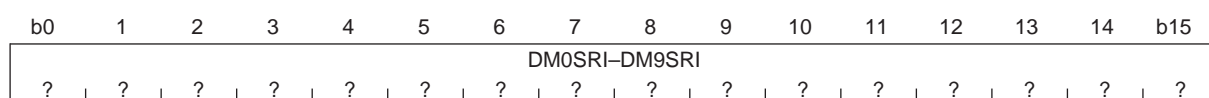
Notes: • When the self channel transfer was allowed during ring buffer mode setting, care must be exercised to its endless transfer.

• The transfer start address must be as follows:

	Transfer Size: 8 bits	Transfer Size: 16 bits
32-time ring buffer mode	Low order 5 bits – B'00000	Low order 6 bits – B'000000
16-time ring buffer mode	Low order 4 bits – B'0000	Low order 5 bits – B'00000
8-time ring buffer mode	Low order 3 bits – B'000	Low order 4 bits – B'0000
4-time ring buffer mode	Low order 2 bits – B'00	Low order 3 bits – B'000
2-time ring buffer mode	Low order 1 bits – B'0	Low order 2 bits – B'00

### 9.2.2 DMA Software Request Generation Registers

DMA0 Software Request Generation Register (DM0SRI)	<Address: H'0080 0460>
DMA1 Software Request Generation Register (DM1SRI)	<Address: H'0080 0462>
DMA2 Software Request Generation Register (DM2SRI)	<Address: H'0080 0464>
DMA3 Software Request Generation Register (DM3SRI)	<Address: H'0080 0466>
DMA4 Software Request Generation Register (DM4SRI)	<Address: H'0080 0468>
DMA5 Software Request Generation Register (DM5SRI)	<Address: H'0080 0470>
DMA6 Software Request Generation Register (DM6SRI)	<Address: H'0080 0472>
DMA7 Software Request Generation Register (DM7SRI)	<Address: H'0080 0474>
DMA8 Software Request Generation Register (DM8SRI)	<Address: H'0080 0476>
DMA9 Software Request Generation Register (DM9SRI)	<Address: H'0080 0478>



<Upon exiting reset: Undefined>

b	Bit Name	Function	R	W
0–15	DM0SRI–DM9SRI DMA software request generation bits	DMA transfer request is generated by writing any data to these bits.	?	W

Note: • This register may be accessed in either bytes or halfwords.

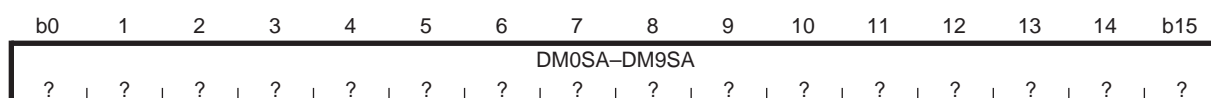
The DMA Software Request Generation Register is used to generate DMA transfer requests in software. A DMA transfer request can be generated by writing any data to this register when “Software start” has been selected for the cause of DMA transfer request.

#### (1) DM0SRI–DM9SRI (DMA Software Request Generation) bits

A software DMA transfer request is generated by writing any data to this register in halfword (16 bits) or in byte (8 bits) beginning with an even or odd address when “Software start” is selected as the cause of DMA transfer request (by setting the DMA<sub>n</sub> Channel Control Register 0 bits 2–3 to “00”).

### 9.2.3 DMA Source Address Registers

DMA0 Source Address Register (DM0SA)	<Address: H'0080 0412>
DMA1 Source Address Register (DM1SA)	<Address: H'0080 0422>
DMA2 Source Address Register (DM2SA)	<Address: H'0080 0432>
DMA3 Source Address Register (DM3SA)	<Address: H'0080 0442>
DMA4 Source Address Register (DM4SA)	<Address: H'0080 0452>
DMA5 Source Address Register (DM5SA)	<Address: H'0080 041A>
DMA6 Source Address Register (DM6SA)	<Address: H'0080 042A>
DMA7 Source Address Register (DM7SA)	<Address: H'0080 043A>
DMA8 Source Address Register (DM8SA)	<Address: H'0080 044A>
DMA9 Source Address Register (DM9SA)	<Address: H'0080 045A>



<Upon exiting reset: Undefined>

b	Bit Name	Function	R	W
0-15	DM0SA-DM9SA	Source address bits A16-A31 (Note 1)	R	W

Note 1: A0 to A15 are fixed by setting DMA<sub>n</sub> Channel Control Register 1 (DM<sub>n</sub>CNT1) bits 8 and 9.

Notes: • This register must always be accessed in halfwords.

- Address other than SFR area and internal RAM area must not be set.

The DMA Source Address Register is used to set the source address of DMA transfer in such a way that bit 0 and bit 15 correspond to A16 and A31, respectively. Because this register is comprised of a current register, the values read from this register are always the current value.

When DMA transfer finishes (i.e., the Transfer Count Register underflows), the value in this register if “Address fixed” is selected, is the same source address that was set in it before the DMA transfer began; if “Address incremental” is selected, the value in this register is the last transfer address + 1 (for 8-bit transfer) or the last transfer address + 2 (for 16-bit transfer).

The DMA Source Address Register must always be accessed in halfwords (16 bits) beginning with an even address. If accessed in bytes, the value in this register is undefined.

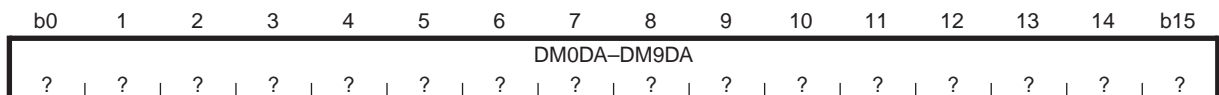
#### (1) DM0SA-DM9SA (Source Address bits A16-A31)

Set this register to specify the source address of DMA transfer in SFR area or internal RAM area.

For high-order 16 bits (A0 to A15) of the source address, the high-order 16 bits of the corresponding source address are fixed by setting of DMA<sub>n</sub> channel control register 1 (DM<sub>n</sub>CNT1) bits 8 and 9. In this register, the low-order 16 bits of the source address are set. (Bit 0 and bit 15 correspond to A16 and A31 of the source address, respectively). Note that when SADSL<sub>n</sub> bit in DMA<sub>n</sub> channel control register (DM<sub>n</sub>CNT0) set to “increment,” no transfer over the bank is carried out. Upon completion of bank transfer to the final address, the bank is to be transferred to the head address.

### 9.2.4 DMA Destination Address Registers

DMA0 Destination Address Register (DM0DA)	<Address: H'0080 0414>
DMA1 Destination Address Register (DM1DA)	<Address: H'0080 0424>
DMA2 Destination Address Register (DM2DA)	<Address: H'0080 0434>
DMA3 Destination Address Register (DM3DA)	<Address: H'0080 0444>
DMA4 Destination Address Register (DM4DA)	<Address: H'0080 0454>
DMA5 Destination Address Register (DM5DA)	<Address: H'0080 041C>
DMA6 Destination Address Register (DM6DA)	<Address: H'0080 042C>
DMA7 Destination Address Register (DM7DA)	<Address: H'0080 043C>
DMA8 Destination Address Register (DM8DA)	<Address: H'0080 044C>
DMA9 Destination Address Register (DM9DA)	<Address: H'0080 045C>



<Upon exiting reset: Undefined>

b	Bit Name	Function	R	W
0-15	DM0DA-DM9DA	Destination address bits A16-A31 (Note 1)	R	W

Note 1: A0 to A15 are fixed by setting DMA<sub>n</sub> Channel Control Register 1 (DM<sub>n</sub>CNT1) bits 10 and 11.

Notes: • This register must always be accessed in halfwords.

- Address other than SFR area and internal RAM area must not be set.

The DMA Destination Address Register is used to set the destination address of DMA transfer in such a way that bit 0 and bit 15 correspond to A16 and A31, respectively. Because this register is comprised of a current register, the values read from this register are always the current value.

When DMA transfer finishes (i.e., the Transfer Count Register underflows), the value in this register if "Address fixed" is selected, is the same source address that was set in it before the DMA transfer began; if "Address incremental" is selected, the value in this register is the last transfer address + 1 (for 8-bit transfer) or the last transfer address + 2 (for 16-bit transfer).

The DMA Destination Address Register must always be accessed in halfwords (16 bits) beginning with an even address. If accessed in bytes, the value in this register is undefined.

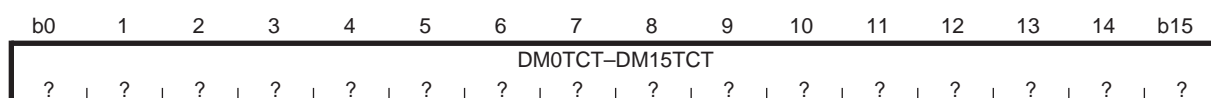
#### (1) DM0DA-DM9DA (Destination Address bits A16-A31)

Set this register to specify the destination address of DMA transfer in SFR area or internal RAM area.

For high-order 16 bits (A0 to A15) of the destination address, Bank 0 to Bank 2 are selected according to the setting of DMA<sub>n</sub> channel control register 1 (DM<sub>n</sub>CNT1) bits 10 and 11, and the high-order 16 bits of the corresponding destination address are fixed. In this register, the low-order 16 bits of the destination address are set. (Bit 0 and bit 15 correspond to A16 and A31 of the destination address, respectively) Note that when SADSL<sub>n</sub> bit in DMA<sub>n</sub> channel control register (DM<sub>n</sub>CNT0) set to "increment," no transfer over the bank is carried out. Upon completion of bank transfer to the final address, the bank is to be transferred to the head address.

### 9.2.5 DMA Transfer Count Registers

DMA0 Transfer Count Register (DM0TCT)	<Address: H'0080 0416>
DMA1 Transfer Count Register (DM1TCT)	<Address: H'0080 0426>
DMA2 Transfer Count Register (DM2TCT)	<Address: H'0080 0436>
DMA3 Transfer Count Register (DM3TCT)	<Address: H'0080 0446>
DMA4 Transfer Count Register (DM4TCT)	<Address: H'0080 0456>
DMA5 Transfer Count Register (DM5TCT)	<Address: H'0080 041E>
DMA6 Transfer Count Register (DM6TCT)	<Address: H'0080 042E>
DMA7 Transfer Count Register (DM7TCT)	<Address: H'0080 043E>
DMA8 Transfer Count Register (DM8TCT)	<Address: H'0080 044E>
DMA9 Transfer Count Register (DM9TCT)	<Address: H'0080 045E>



<Upon exiting reset: Undefined>

b	Bit Name	Function	R	W
0-15	DM0TCT-DM9TCT (Has no effect during ring buffer mode)	DMA transfer count	R	W

Note: • This register must always be accessed in halfwords.

The DMA Transfer Count Register is used to set the number of times data is transferred on each channel. However, the value in this register has no effect during ring buffer mode.

The transfer count is the value set in the transfer count register + 1. Because the DMA Transfer Count Register is comprised of a current register, the values read from this register are always the current value. (However, if the register is read in a cycle immediately after transfer, the value obtained is one that was stored in the count register before the transfer began.) When transfer finishes, this count register underflows and the value read from it is H'FFFF.

When transfer is enabled, this register is protected in hardware and cannot be accessed for write.

During ring buffer mode, the transfer count register counts down in free-run mode and continues counting until transfer is disabled. No interrupt is generated at underflow.

If any cascaded channel exists, each time one DMA transfer (byte or halfword) is completed or when all transfers on a channel are completed (i.e., the transfer count register underflows), transfer on the cascaded channel starts.

The DMA Transfer Count Register must always be accessed in halfwords (16 bits) beginning with an even address. If accessed in bytes, the value in this register is undefined.

### 9.2.6 DMA Interrupt Related Registers

The DMA interrupt related registers are used to control the interrupt request signals sent from the DMAC to the Interrupt Controller.

#### (1) Interrupt request status bit

This status bit is used to determine whether there is an interrupt request. When an interrupt request occurs, this bit is set in hardware (cannot be set in software). The status bit is cleared by writing "0." Writing "1" has no effect; the bit retains the status it had before the write. Because this status bit is unaffected by the interrupt request mask bit, it can be used to inspect the operating status of peripheral functions.

In interrupt handling, make sure that within the grouped interrupt request status, only the status bit for the interrupt request that has been serviced is cleared. If the status bit for any interrupt request that has not been serviced is cleared, the pending interrupt request is cleared simultaneously with its status bit.

#### (2) Interrupt request mask bit

This bit is used to disable unnecessary interrupt requests within the grouped interrupt request. Set this bit to "0" to enable interrupt requests or "1" to disable interrupt requests.

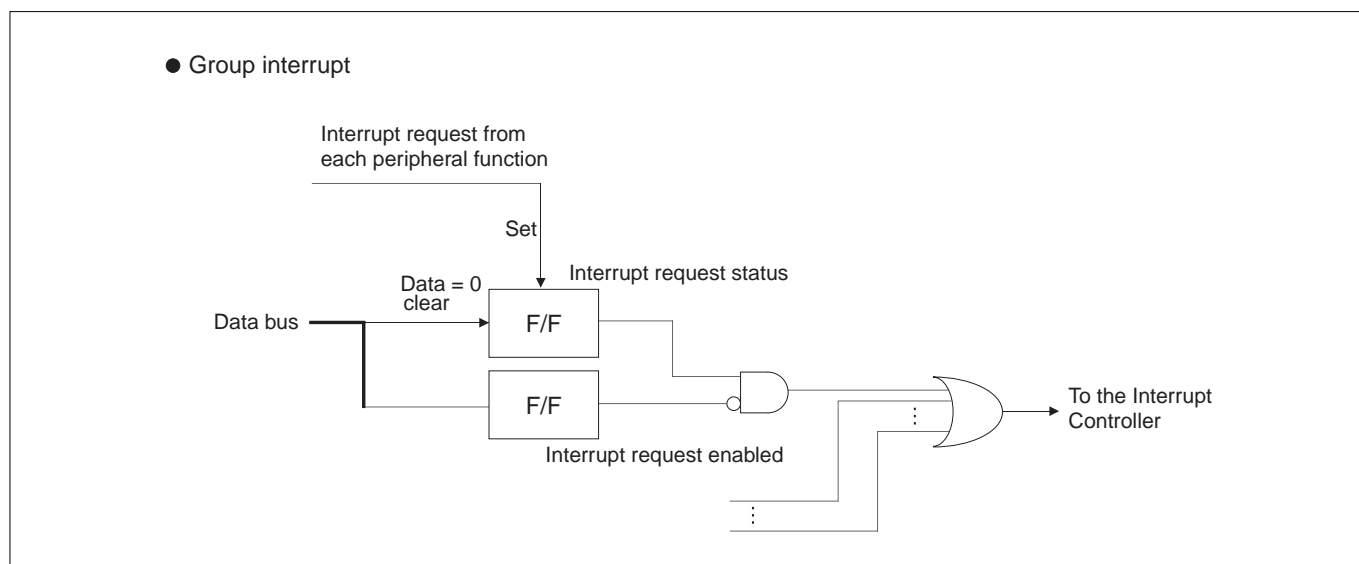
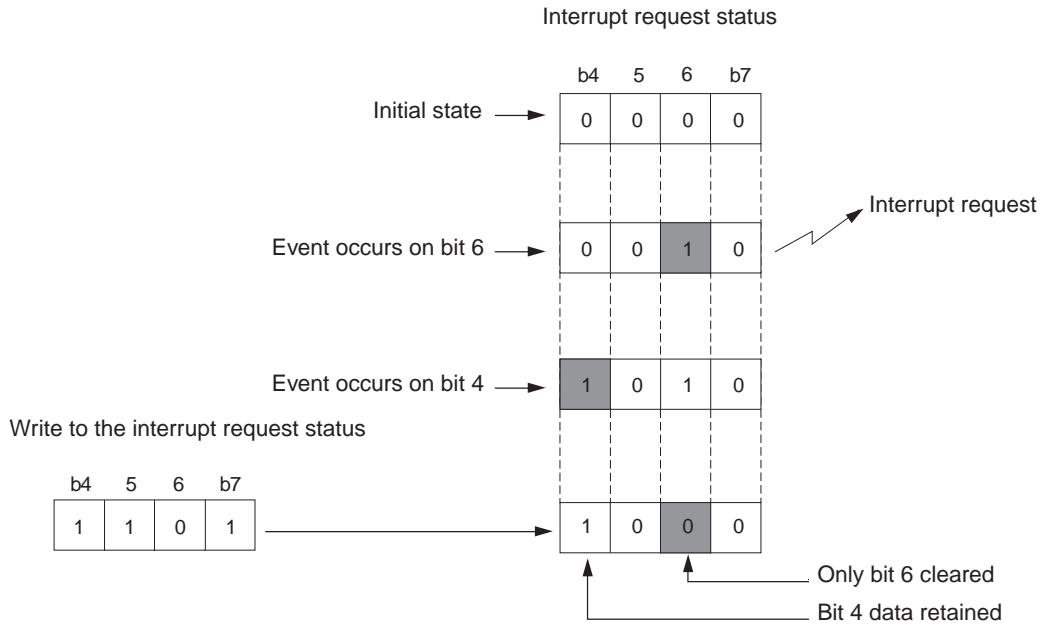


Figure 9.2.2 Interrupt Request Status and Mask Registers

● Example for clearing interrupt request status



● Program example

- To clear the Interrupt Request Status Register 0 (ISTREG) interrupt request status 1, ISTAT1 (0x02 bit)



```
ISTREG = 0xfd; /* Clear ISTAT1 (0x02 bit) only */
```

To clear an interrupt request status, always be sure to write "1" to all other interrupt request status bits. At this time, avoid using a logic operation like the one shown below. Because it requires three step-ISTREG read, logic operation and write, if another interrupt request occurs between the read and write, status may be inadvertently cleared.



```
ISTREG &= 0xfd; /* Clear ISTAT1 (0x02 bit) only */
```

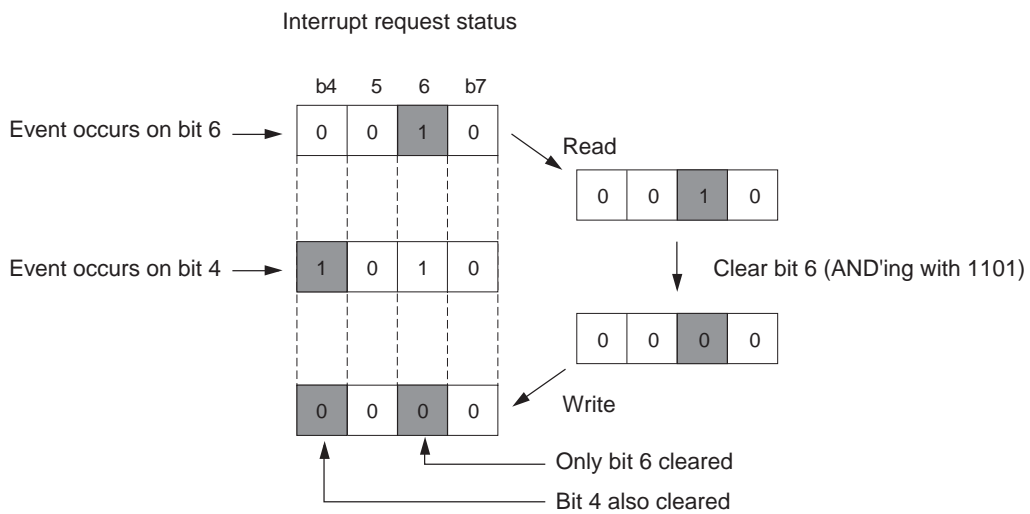


Figure 9.2.3 Example for Clearing Interrupt Request Status



DMA0–4 Interrupt Request Status Register (DM04ITST)

&lt;Address: H'0080 0400&gt;

b0	1	2	3	4	5	6	b7
0			DMITST4	DMITST3	DMITST2	DMITST1	DMITST0
0			0	0	0	0	0

&lt;Upon exiting reset: H'00&gt;

b	Bit Name	Function	R	W
0–2	No function assigned. Fix to "0."		0	0
3	DMITST4 (DMA4 interrupt request status bit)	0: Interrupt not requested	R	(Note 1)
4	DMITST3 (DMA3 interrupt request status bit)	1: Interrupt requested		
5	DMITST2 (DMA2 interrupt request status bit)			
6	DMITST1 (DMA1 interrupt request status bit)			
7	DMITST0 (DMA0 interrupt request status bit)			

Note 1: Only writing "0" is effective. Writing "1" has no effect; the bit retains the value it had before the write.

DMA5–9 Interrupt Request Status Register (DM59ITST)

&lt;Address: H'0080 0408&gt;

b0	1	2	3	4	5	6	b7
0			DMITST9	DMITST8	DMITST7	DMITST6	DMITST5
0			0	0	0	0	0

&lt;Upon exiting reset: H'00&gt;

b	Bit Name	Function	R	W
0–2	No function assigned. Fix to "0."		0	0
3	DMITST9 (DMA9 interrupt request status bit)	0: Interrupt not requested	R	(Note 1)
4	DMITST8 (DMA8 interrupt request status bit)	1: Interrupt requested		
5	DMITST7 (DMA7 interrupt request status bit)			
6	DMITST6 (DMA6 interrupt request status bit)			
7	DMITST5 (DMA5 interrupt request status bit)			

Note 1: Only writing "0" is effective. Writing "1" has no effect; the bit retains the value it had before the write.

The Interrupt Request Status Register helps to know the status of interrupt requests on each channel. If the DMA $n$  interrupt request status bit ( $n = 0–9$ ) is set to "1," it means that a DMA interrupt request on the corresponding channel has been generated.

### (1) DMITST $n$ (DMA $n$ Interrupt Request Status) bit ( $n = 0–9$ )

#### [Setting the DMA $n$ interrupt request status bit]

This bit is set in hardware, and cannot be set in software.

#### [Clearing the DMA $n$ interrupt request status bit]

This bit is cleared by writing "0" in software.

Note: • The DMA $n$  interrupt request status bit cannot be cleared by writing "0" to the DMA Interrupt Control Register's "interrupt request bit" included in the Interrupt Controller.

When writing to the DMA Interrupt Request Status Register, make sure only the bits to be cleared are set to "0" and all other bits are set to "1." Those bits that have been set to "1" are unaffected by writing in software and retain the value they had before the write.

DMA0–4 Interrupt Request Mask Register (DM04ITMK)

&lt;Address: H'0080 0401&gt;

b8	9	10	11	12	13	14	b15
0   0   0			DMITMK4	DMITMK3	DMITMK2	DMITMK1	DMITMK0
0   0   0			0	0	0	0	0

&lt;Upon exiting reset: H'00&gt;

b	Bit Name	Function	R	W
8–10	No function assigned. Fix to "0."		0	0
11	DMITMK4 (DMA4 interrupt request mask bit)	0: Enable interrupt request	R	W
12	DMITMK3 (DMA3 interrupt request mask bit)	1: Mask (disable) interrupt request		
13	DMITMK2 (DMA2 interrupt request mask bit)			
14	DMITMK1 (DMA1 interrupt request mask bit)			
15	DMITMK0 (DMA0 interrupt request mask bit)			

DMA5–9 Interrupt Request Mask Register (DM59ITMK)

&lt;Address: H'0080 0409&gt;

b8	9	10	11	12	13	14	b15
0   0   0			DMITMK9	DMITMK8	DMITMK7	DMITMK6	DMITMK5
0   0   0			0	0	0	0	0

&lt;Upon exiting reset: H'00&gt;

b	Bit Name	Function	R	W
8–10	No function assigned. Fix to "0."		0	0
11	DMITMK9 (DMA9 interrupt request mask bit)	0: Enable interrupt request	R	W
12	DMITMK8 (DMA8 interrupt request mask bit)	1: Mask (disable) interrupt request		
13	DMITMK7 (DMA7 interrupt request mask bit)			
14	DMITMK6 (DMA6 interrupt request mask bit)			
15	DMITMK5 (DMA5 interrupt request mask bit)			

The DMA Interrupt Request Mask Register is used to mask interrupt requests on each DMA channel.

### (1) DMITMK<sub>n</sub> (DMA<sub>n</sub> Interrupt Request Mask) bit (n = 0–9)

Setting the DMA<sub>n</sub> interrupt request mask bit to "1" masks the interrupt requests on DMA<sub>n</sub> channel. However, if an interrupt request occurs, the DMA<sub>n</sub> interrupt request status bit is always set to "1" irrespective of the contents of this mask register.

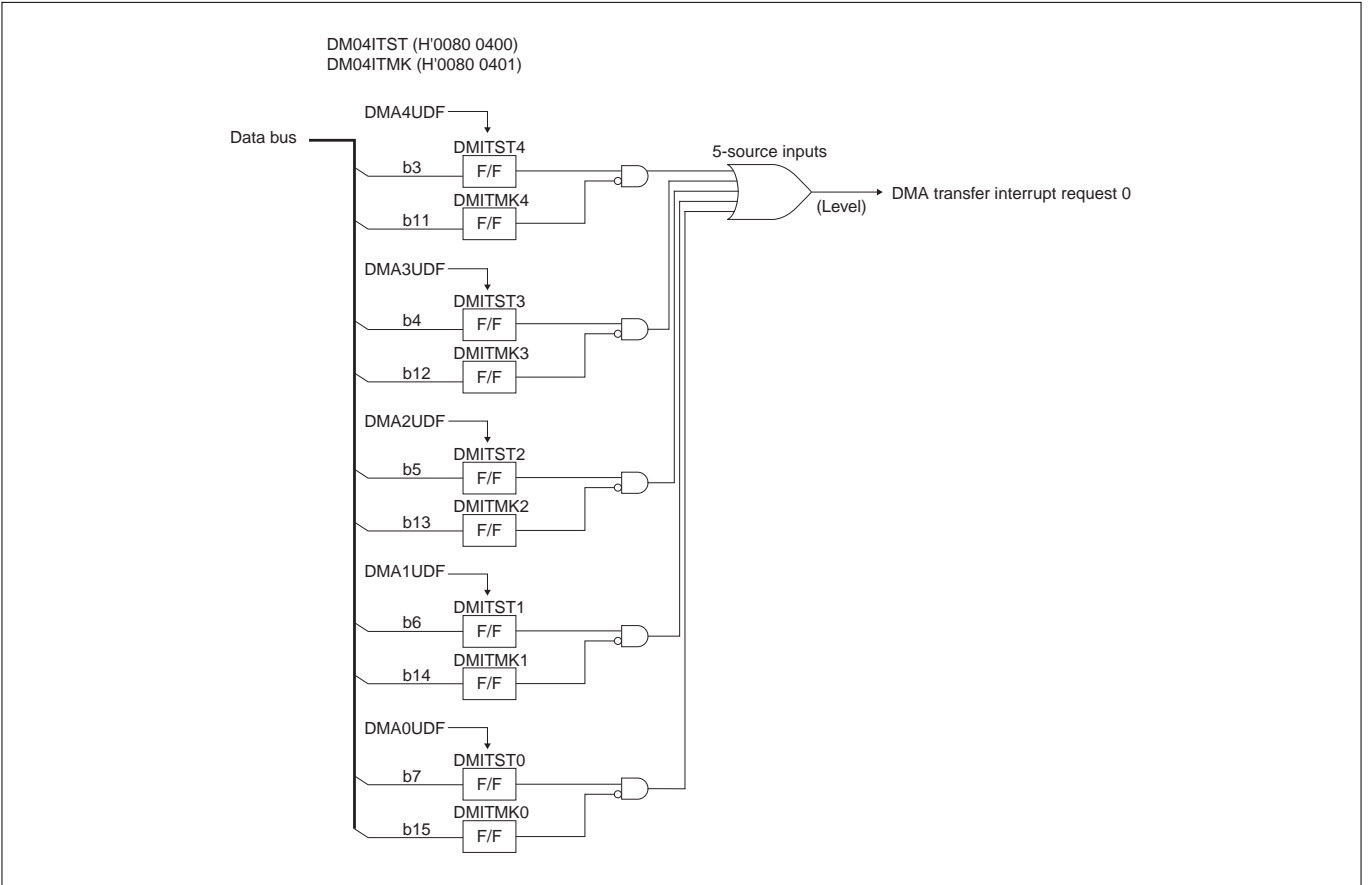


Figure 9.2.4 Block Diagram of DMA Transfer Interrupt Request 0

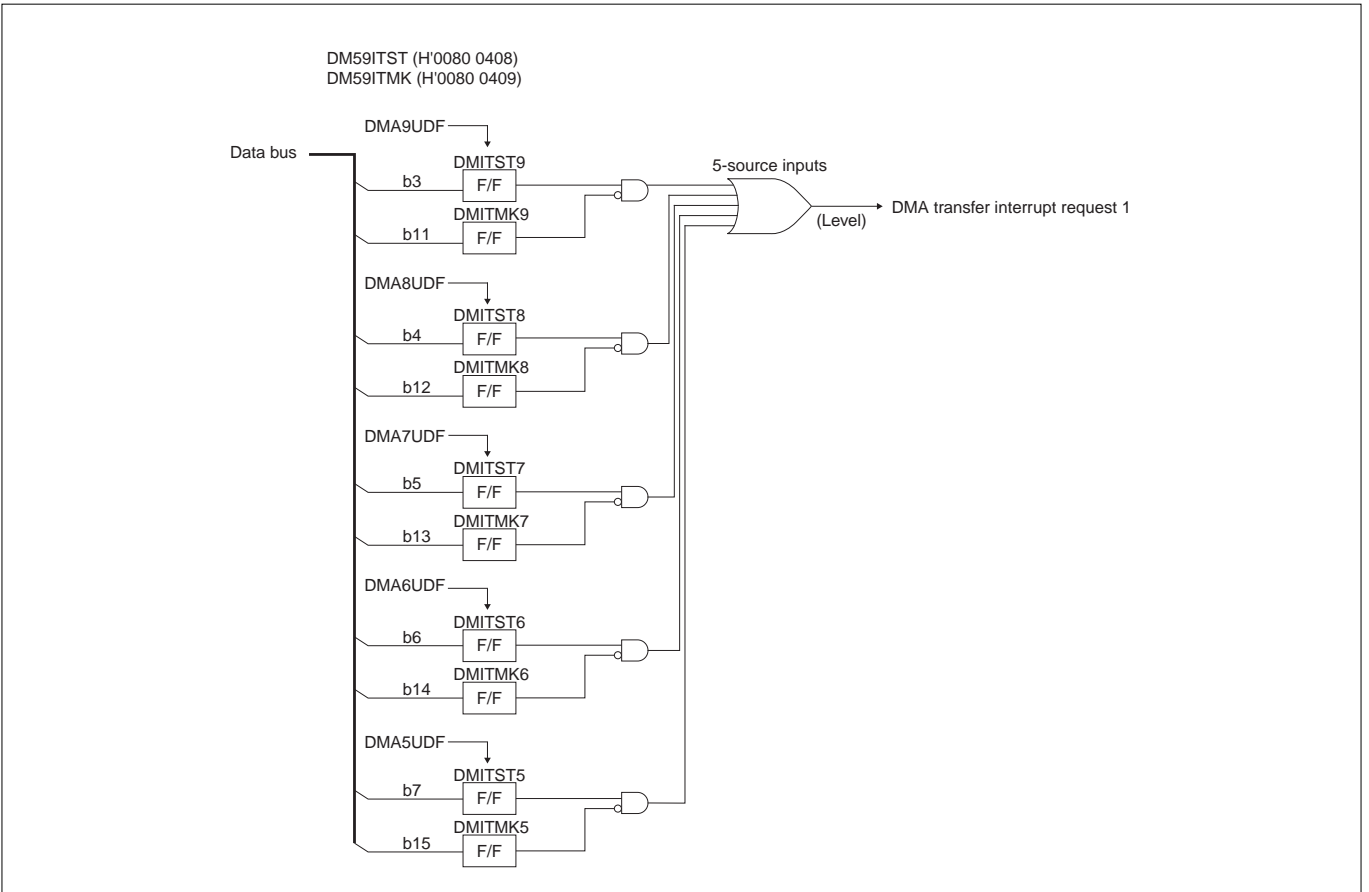


Figure 9.2.5 Block Diagram of DMA Transfer Interrupt Request 1

## 9.3 Functional Description of the DMAC

### 9.3.1 DMA Transfer Request Sources

For each DMA channel (channels 0–9), DMA transfer can be requested from two or more sources. There are various causes or sources of DMA transfer request, so that DMA transfer can be started by a request from some internal peripheral I/O, in software by a program, or upon completion of one transfer or all transfers on another DMA channel (cascade mode).

The causes or sources of DMA transfer requests are selected using the transfer request source select bits REQSLn on each channel (DMA<sub>n</sub> Channel Control Register 0 bits 2–3) or the extended transfer request source select bits REQESELn (DMA<sub>n</sub> Channel Control Register 1 bits 12–15). The tables below list the causes or sources of DMA transfer requests on each channel.

**Table 9.3.1 DMA Transfer Request Sources and Generation Timings on DMA0**

REQSL0	DMA Transfer Request Source	DMA Transfer Request Generation Timing
0 0	Software start or one DMA2 transfer completed	When any data is written to the DMA0 Software Request Generation Register (software start) or when one DMA2 transfer is completed (cascade mode)
0 1	A/D0 conversion completed	When A/D0 conversion is completed
1 0	MJT (TIO8_ufd)	When MJT TIO8 underflows
1 1	Extended DMA0 transfer request source selected	The source selected by the DMA0 Channel Control Register 1 (DM0CNT1) REQESEL0 bits (see below)

REQESEL0	DMA Transfer Request Source	DMA Transfer Request Generation Timing
0000	MJT (input event bus 2)	When MJT input event bus 2 signal is generated
0001	MJT (TID0_ufd/ovf)	When MJT TID0 underflow/overflow occurs
0010	CAN (CAN0_S0/S31)	When CAN0 slot 0 transmission failed or slot 31 transmission/reception finished
0011	Common 1) MJT (input event bus 1)	When MJT input event bus 1 signal is generated
0100	Common 2) MJT (input event bus 3)	When MJT input event bus 3 signal is generated
0101	Common 3) MJT (output event bus 2)	When MJT output event bus 2 signal is generated
0110	Common 4) MJT (output event bus 3)	When MJT output event bus 3 signal is generated
0111	Common 5) A/D0 conversion completed	When A/D0 conversion is completed
1000	Common 6) MJT (TIN0S)	When MJT TIN0 input signal is generated
1001	Common 7) MJT (TIO8_ufd)	When MJT TIO8 underflow occurs
1010	Common 8) MJT (TIN30S)	When MJT TIN30 input signal is generated
1011	Common 9) MJT (TIO9_ufd)	When MJT TIO9 underflow occurs
1100	Common 10) Settings inhibited	–
1101	MJT (TOU1_0irq)	When MJT TOU1_0 interrupt request is generated
1110	DRI (DIN0)	When DRI DIN0 event detection interrupt is generated
1111	SIO4_TXD (transmit buffer empty)	When SIO4 transmit buffer empty interrupt is generated

**Table 9.3.2 DMA Transfer Request Sources and Generation Timings on DMA1**

REQSL1	DMA Transfer Request Source	DMA Transfer Request Generation Timing
0 0	Software start	When any data is written to the DMA1 Software Request Generation Register
0 1	MJT (output event bus 0)	When MJT output event bus 0 signal is generated
1 0	Settings inhibited	–
1 1	Extended DMA1 transfer request source selected	The source selected by the DMA1 Channel Control Register 1 (DM1CNT1) REQESEL1 bits (see below)

REQESEL1	DMA Transfer Request Source	DMA Transfer Request Generation Timing
0000	One DMA0 transfer completed	When one DMA0 transfer is completed (cascade mode)
0001	MJT (TIN3S)	When MJT TIN3 input signal is generated
0010	MJT (TID1_udf/ovf)	When MJT TID1 underflow/overflow occurs
0011	Common 1) MJT (input event bus 1)	When MJT input event bus 1 signal is generated
0100	Common 2) MJT (input event bus 3)	When MJT input event bus 3 signal is generated
0101	Common 3) MJT (output event bus 2)	When MJT output event bus 2 signal is generated
0110	Common 4) MJT (output event bus 3)	When MJT output event bus 3 signal is generated
0111	Common 5) A/D0 conversion completed	When A/D0 conversion is completed
1000	Common 6) MJT (TIN0S)	When MJT TIN0 input signal is generated
1001	Common 7) MJT (TIO8_udf)	When MJT TIO8 underflow occurs
1010	Common 8) MJT (TIN30S)	When MJT TIN30 input signal is generated
1011	Common 9) MJT (TIO9_udf)	When MJT TIO9 underflow occurs
1100	Common 10) Settings inhibited	–
1101	MJT (TOU1_1irq)	When TOU1_1 interrupt request is generated
1110	DRI (DIN1)	When DRI DIN1 event detection interrupt is generated
1111	SIO4_RXD (reception completed)	When SIO4 reception-completed interrupt is generated

**Table 9.3.3 DMA Transfer Request Sources and Generation Timings on DMA2**

REQSL2	DMA Transfer Request Source	DMA Transfer Request Generation Timing
0 0	Software start	When any data is written to the DMA2 Software Request Generation Register
0 1	MJT (output event bus 1)	When MJT output event bus 1 signal is generated
1 0	MJT (TIN18S)	When MJT TIN18 input signal is generated
1 1	Extended DMA2 transfer request source selected	The source selected by the DMA2 Channel Control Register 1 (DM2CNT1) REQESEL2 bits (see below)

REQESEL2	DMA Transfer Request Source	DMA Transfer Request Generation Timing
0000	One DMA1 transfer completed	When one DMA1 transfer is completed (cascade mode)
0001	Settings inhibited	–
0010	CAN(CAN0_S1/S30)	When CAN0 slot 1 transmission failed or slot 30 transmission/reception finished
0011	Common 1) MJT (input event bus 1)	When MJT input event bus 1 signal is generated
0100	Common 2) MJT (input event bus 3)	When MJT input event bus 3 signal is generated
0101	Common 3) MJT (output event bus 2)	When MJT output event bus 2 signal is generated
0110	Common 4) MJT (output event bus 3)	When MJT output event bus 3 signal is generated
0111	Common 5) A/D0 conversion completed	When A/D0 conversion is completed
1000	Common 6) MJT (TIN0S)	When MJT TIN0 input signal is generated
1001	Common 7) MJT (TIO8_udf)	When MJT TIO8 underflow occurs
1010	Common 8) MJT (TIN30S)	When MJT TIN30 input signal is generated
1011	Common 9) MJT (TIO9_udf)	When MJT TIO9 underflow occurs
1100	Common 10) Settings inhibited	–
1101	Settings inhibited	–
1110	DRI (DIN2)	When DRI DIN2 event detection interrupt is generated
1111	SIO5_TXD (transmit buffer empty)	When SIO5 transmit buffer empty interrupt is generated

**Table 9.3.4 DMA Transfer Request Sources and Generation Timings on DMA3**

REQSL3	DMA Transfer Request Source	DMA Transfer Request Generation Timing
0 0	Software start	When any data is written to the DMA3 Software Request Generation Register
0 1	SIO0_TXD (transmit buffer empty)	When SIO0 transmit buffer is empty
1 0	SIO1_RXD (reception completed)	When SIO1 reception is completed
1 1	Extended DMA3 transfer request source selected	The source selected by the DMA3 Channel Control Register 1 (DM3CNT1) REQESEL3 bits (see below)

REQESEL3	DMA Transfer Request Source	DMA Transfer Request Generation Timing
0000	MJT (TIN0S)	When MJT TIN0 input signal is generated
0001	One DMA2 transfer completed	When one DMA2 transfer is completed (cascade mode)
0010	Settings inhibited	–
0011	Common 1) MJT (input event bus 1)	When MJT input event bus 1 signal is generated
0100	Common 2) MJT (input event bus 3)	When MJT input event bus 3 signal is generated
0101	Common 3) MJT (output event bus 2)	When MJT output event bus 2 signal is generated
0110	Common 4) MJT (output event bus 3)	When MJT output event bus 3 signal is generated
0111	Common 5) A/D0 conversion completed	When A/D0 conversion is completed
1000	Common 6) MJT (TIN0S)	When MJT TIN0 input signal is generated
1001	Common 7) MJT (TIO8_ufd)	When MJT TIO8 underflow occurs
1010	Common 8) MJT (TIN30S)	When MJT TIN30 input signal is generated
1011	Common 9) MJT (TIO9_ufd)	When MJT TIO9 underflow occurs
1100	Common 10) Settings inhibited	–
1101	MJT (TOU1_6irq)	When MJT TOU1_6 interrupt request is generated
1110	DRI (DIN3)	When DRI DIN3 event detection interrupt is generated
1111	SIO5_RXD (reception completed)	When SIO5 reception-completed interrupt is generated

**Table 9.3.5 DMA Transfer Request Sources and Generation Timings on DMA4**

REQSL4	DMA Transfer Request Source	DMA Transfer Request Generation Timing
0 0	Software start	When any data is written to the DMA4 Software Request Generation Register
0 1	One DMA3 transfer completed	When one DMA3 transfer is completed (cascade mode)
1 0	SIO0_RXD (reception completed)	When SIO0 reception is completed
1 1	Extended DMA4 transfer request source selected	The source selected by the DMA4 Channel Control Register 1 (DM4CNT1) REQESEL4 bits (see below)

REQESEL4	DMA Transfer Request Source	DMA Transfer Request Generation Timing
0000	MJT (TIN19S)	When MJT TIN19 input signal is generated
0001	SIO0_TXD (transmit buffer empty)	When SIO0 transmit buffer is empty
0010	MJT (TOU1_7irq)	MJT TOU1_7 interrupt source
0011	Common 1) MJT (input event bus 1)	When MJT input event bus 1 signal is generated
0100	Common 2) MJT (input event bus 3)	When MJT input event bus 3 signal is generated
0101	Common 3) MJT (output event bus 2)	When MJT output event bus 2 signal is generated
0110	Common 4) MJT (output event bus 3)	When MJT output event bus 3 signal is generated
0111	Common 5) A/D0 conversion completed	When A/D0 conversion is completed
1000	Common 6) MJT (TIN0S)	When MJT TIN0 input signal is generated
1001	Common 7) MJT (TIO8_ufd)	When MJT TIO8 underflow occurs
1010	Common 8) MJT (TIN30S)	When MJT TIN30 input signal is generated
1011	Common 9) MJT (TIO9_ufd)	When MJT TIO9 underflow occurs
1100	Common 10) Settings inhibited	–
1101	MJT (TIN7S)	When MJT TIN7 input signal is generated
1110	DRI (DIN4)	When DRI DIN4 event detection interrupt is generated
1111	Settings inhibited	–

**Table 9.3.6 DMA Transfer Request Sources and Generation Timings on DMA5**

REQSL5	DMA Transfer Request Source	DMA Transfer Request Generation Timing
0 0	Software start or one DMA7 transfer completed	When any data is written to the DMA5 Software Request Generation Register or when one DMA7 transfer is completed (cascade mode)
0 1	All DMA0 transfers completed	When all DMA0 transfers are completed (cascade mode)
1 0	SIO2_RXD (reception completed)	When SIO2 reception is completed
1 1	Extended DMA5 transfer request source selected	The source selected by the DMA5 Channel Control Register 1 (DM5CNT1) REQESEL5 bits (see below)

REQESEL5	DMA Transfer Request Source	DMA Transfer Request Generation Timing
0000	MJT (TIN20S)	When MJT TIN20 input signal is generated
0001	MJT (TOU0_0irq)	MJT TOU0_0 interrupt source
0010	Settings inhibited	–
0011	Common 1) MJT (input event bus 1)	When MJT input event bus 1 signal is generated
0100	Common 2) MJT (input event bus 3)	When MJT input event bus 3 signal is generated
0101	Common 3) MJT (output event bus 2)	When MJT output event bus 2 signal is generated
0110	Common 4) MJT (output event bus 3)	When MJT output event bus 3 signal is generated
0111	Common 5) A/D0 conversion completed	When A/D0 conversion is completed
1000	Common 6) MJT (TIN0S)	When MJT TIN0 input signal is generated
1001	Common 7) MJT (TIO8_udf)	When MJT TIO8 underflow occurs
1010	Common 8) MJT (TIN30S)	When MJT TIN30 input signal is generated
1011	Common 9) MJT (TIO9_udf)	When MJT TIO9 underflow occurs
1100	Common 10) Settings inhibited	–
1101	MJT (TIN8S)	When MJT TIN8 input signal is generated
1110	DRI (DEC0_udf)	When DRI DEC0 underflow occurs
1111	CAN1_S0/S31	When CAN1 slot 0 transmission failed or slot 31 transmission/reception finished

**Table 9.3.7 DMA Transfer Request Sources and Generation Timings on DMA6**

REQSL6	DMA Transfer Request Source	DMA Transfer Request Generation Timing
0 0	Software start	When any data is written to the DMA6 Software Request Generation Register
0 1	SIO1_TXD (transmit buffer empty)	When SIO1 transmit buffer is empty
1 0	CAN0_S0/S31	When CAN0 slot 0 transmission failed or slot 31 transmission/reception finished
1 1	Extended DMA6 transfer request source selected	The source selected by the DMA6 Channel Control Register 1 (DM6CNT1) REQESEL6 bits (see below)

REQESEL6	DMA Transfer Request Source	DMA Transfer Request Generation Timing
0000	One DMA5 transfer completed	When one DMA5 transfer is completed (cascade mode)
0001	MJT (TOU0_1irq)	MJT TOU0_1 interrupt source
0010	SIO1_RXD (reception completed)	When SIO1 reception is completed
0011	Common 1) MJT (input event bus 1)	When MJT input event bus 1 signal is generated
0100	Common 2) MJT (input event bus 3)	When MJT input event bus 3 signal is generated
0101	Common 3) MJT (output event bus 2)	When MJT output event bus 2 signal is generated
0110	Common 4) MJT (output event bus 3)	When MJT output event bus 3 signal is generated
0111	Common 5) A/D0 conversion completed	When A/D0 conversion is completed
1000	Common 6) MJT (TIN0S)	When MJT TIN0 input signal is generated
1001	Common 7) MJT (TIO8_udf)	When MJT TIO8 underflow occurs
1010	Common 8) MJT (TIN30S)	When MJT TIN30 input signal is generated
1011	Common 9) MJT (TIO9_udf)	When MJT TIO9 underflow occurs
1100	Common 10) Settings inhibited	–
1101	DRI address counter 0 transfer completed	When DRI address counter 0 transfer completed
1110	DRI (DEC1_udf)	When DRI DEC1 underflow occurs
1111	Settings inhibited	–



**Table 9.3.8 DMA Transfer Request Sources and Generation Timings on DMA7**

REQSL7	DMA Transfer Request Source	DMA Transfer Request Generation Timing
0 0	Software start	When any data is written to the DMA7 Software Request Generation Register
0 1	SIO2_TXD (transmit buffer empty)	When SIO2 transmit buffer is empty
1 0	CAN0_S1/S30	When CAN0 slot 1 transmission failed or slot 30 transmission/reception finished
1 1	Extended DMA7 transfer request source selected	The source selected by the DMA7 Channel Control Register 1 (DM7CNT1) REQESL7 bits (see below)

REQESEL7	DMA Transfer Request Source	DMA Transfer Request Generation Timing
0000	One DMA6 transfer completed	When one DMA6 transfer is completed (cascade mode)
0001	MJT (TOU0_2irq)	MJT TOU0_2 interrupt source
0010	SIO3_TXD (transmit buffer empty)	When SIO3 transmit buffer is empty
0011	Common 1) MJT (input event bus 1)	When MJT input event bus 1 signal is generated
0100	Common 2) MJT (input event bus 3)	When MJT input event bus 3 signal is generated
0101	Common 3) MJT (output event bus 2)	When MJT output event bus 2 signal is generated
0110	Common 4) MJT (output event bus 3)	When MJT output event bus 3 signal is generated
0111	Common 5) A/D0 conversion completed	When A/D0 conversion is completed
1000	Common 6) MJT (TIN0S)	When MJT TIN0 input signal is generated
1001	Common 7) MJT (TIO8_ufd)	When MJT TIO8 underflow occurs
1010	Common 8) MJT (TIN30S)	When MJT TIN30 input signal is generated
1011	Common 9) MJT (TIO9_ufd)	When MJT TIO9 underflow occurs
1100	Common 10) Settings inhibited	–
1101	DRI address counter 1 transfer completed	When DRI address counter 1 transfer completed
1110	DRI (DEC2_ufd)	When DRI DEC2 underflow occurs
1111	CAN1_S1/S30	When CAN1 slot 1 transmission failed or slot 30 transmission/reception finished

**Table 9.3.9 DMA Transfer Request Sources and Generation Timings on DMA8**

REQSL8	DMA Transfer Request Source	DMA Transfer Request Generation Timing
0 0	Software start	When any data is written to the DMA8 Software Request Generation Register
0 1	MJT (input event bus 0)	When MJT input event bus 0 signal is generated
1 0	SIO3_RXD (reception completed)	When SIO3 reception is completed
1 1	Extended DMA8 transfer request source selected	The source selected by the DMA8 Channel Control Register 1 (DM8CNT1) REQESL8 bits (see below)

REQESEL8	DMA Transfer Request Source	DMA Transfer Request Generation Timing
0000	CAN1_S0/S31	When CAN1 slot 0 transmission failed or slot 31 transmission/reception finished
0001	MJT (TOU0_6irq)	MJT TOU0_6 interrupt source
0010	One DMA7 transfer completed	When one DMA7 transfer is completed (cascade mode)
0011	Common 1) MJT (input event bus 1)	When MJT input event bus 1 signal is generated
0100	Common 2) MJT (input event bus 3)	When MJT input event bus 3 signal is generated
0101	Common 3) MJT (output event bus 2)	When MJT output event bus 2 signal is generated
0110	Common 4) MJT (output event bus 3)	When MJT output event bus 3 signal is generated
0111	Common 5) A/D0 conversion completed	When A/D0 conversion is completed
1000	Common 6) MJT (TIN0S)	When MJT TIN0 input signal is generated
1001	Common 7) MJT (TIO8_ufd)	When MJT TIO8 underflow occurs
1010	Common 8) MJT (TIN30S)	When MJT TIN30 input signal is generated
1011	Common 9) MJT (TIO9_ufd)	When MJT TIO9 underflow occurs
1100	Common 10) Settings inhibited	–
1101	DRI latch event counter_ufd	When DRI latch event counter underflow occurs
1110	DRI (DEC3_ufd)	When DRI DEC3 underflow occurs
1111	Settings inhibited	–



**Table 9.3.10 DMA Transfer Request Sources and Generation Timings on DMA9**

REQSL9	DMA Transfer Request Source	DMA Transfer Request Generation Timing
0 0	Software start	When any data is written to the DMA9 Software Request Generation Register
0 1	SIO3_TXD (transmit buffer empty)	When SIO3 transmit buffer is empty
1 0	CAN1_S1/S30	When CAN1 slot 1 transmission failed or slot 30 transmission/reception finished
1 1	Extended DMA9 transfer request source selected	The source selected by the DMA9 Channel Control Register 1 (DM9CNT1) REQSEL9 bits (see below)

REQSEL9	DMA Transfer Request Source	DMA Transfer Request Generation Timing
0000	One DMA8 transfer completed	When one DMA8 transfer is completed (cascade mode)
0001	MJT (TOU0_7irq)	MJT TOU0_7 interrupt source
0010	Settings inhibited	–
0011	Common 1) MJT (input event bus 1)	When MJT input event bus 1 signal is generated
0100	Common 2) MJT (input event bus 3)	When MJT input event bus 3 signal is generated
0101	Common 3) MJT (output event bus 2)	When MJT output event bus 2 signal is generated
0110	Common 4) MJT (output event bus 3)	When MJT output event bus 3 signal is generated
0111	Common 5) A/D0 conversion completed	When A/D0 conversion is completed
1000	Common 6) MJT (TIN0S)	When MJT TIN0 input signal is generated
1001	Common 7) MJT (TIO8_udf)	When MJT TIO8 underflow occurs
1010	Common 8) MJT (TIN30S)	When MJT TIN30 input signal is generated
1011	Common 9) MJT (TIO9_udf)	When MJT TIO9 underflow occurs
1100	Common 10) Settings inhibited	–
1101	DRI transfer counter_udf	When DRI transfer counter underflow occurs
1110	DRI (DEC4_udf)	When DRI DEC4 underflow occurs
1111	DRI (DIN5)	When DRI DIN5 event detection interrupt is generated

### 9.3.2 DMA Transfer Processing Procedure

Shown below is an example of how to control DMA transfer in cases when performing transfer on DMA channel 0.

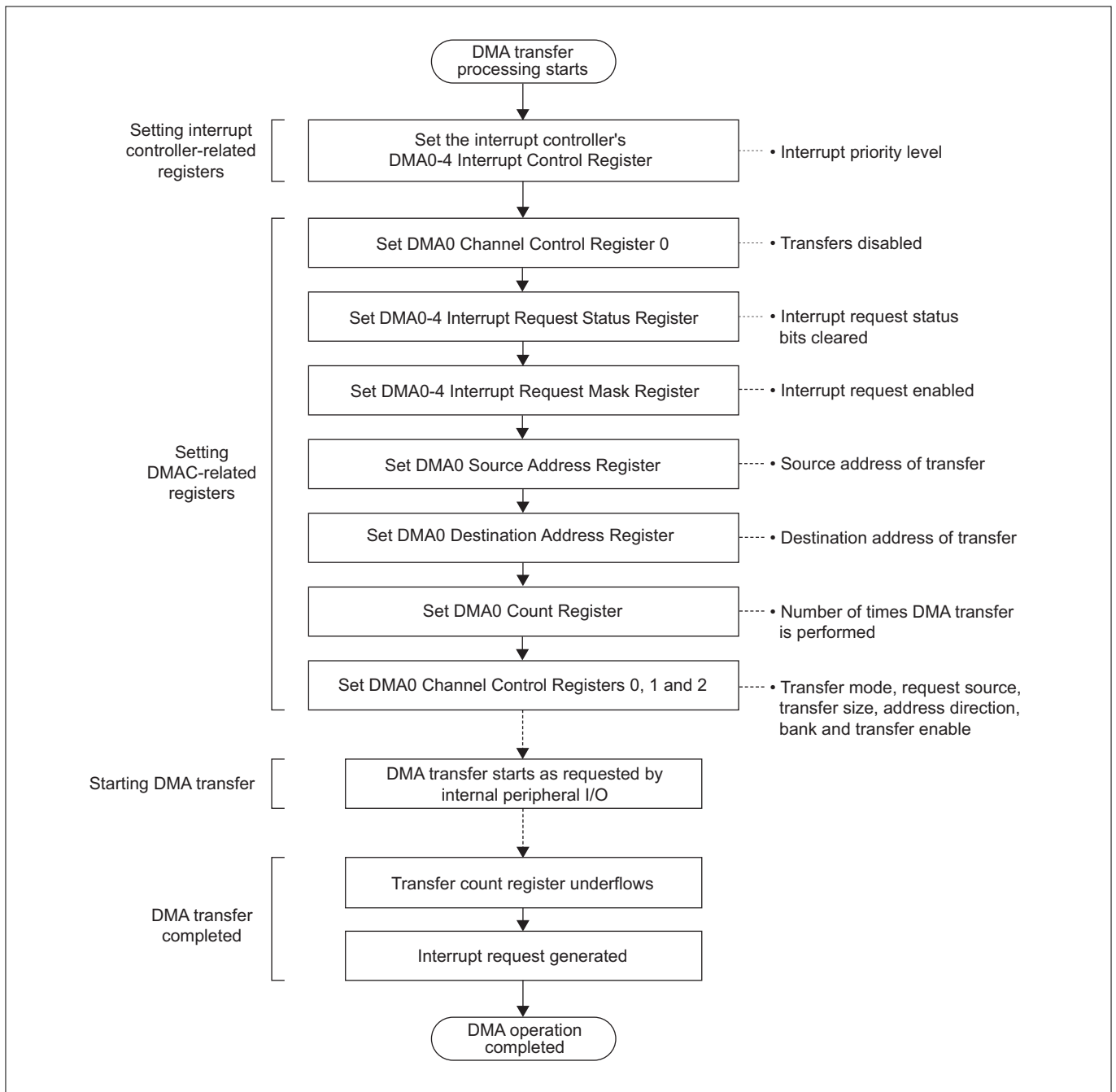


Figure 9.3.1 Example of a DMA Transfer Processing Procedure

### 9.3.3 Starting DMA

Use the DMA Channel Control Register 0 REQSL (DMA transfer request source select) and DMA Channel Control Register 1 REQESEL (extended DMA transfer request source select) bits to set the cause or source of DMA transfer request. To enable DMA, set the TENL (DMA transfer enable) bit to "1." DMA transfer begins when the specified cause or source of DMA transfer request becomes effective after setting the TENL (DMA transfer enable) bit to "1."

Note: • If the transfer request source selected by the REQSL (DMA transfer request source select) and REQESEL (extended DMA transfer request source select) bits is MJT (TIN input signal), the time required for DMA transfer to begin after detecting the rising or falling or both edges of the TIN input signal is three cycles (75 ns when the internal peripheral clock = 40 MHz) at the shortest. Or, depending on the preceding or following bus usage condition, up to five cycles (125 ns when the internal peripheral clock = 40 MHz) may be required. (However, this applies when the external bus, HOLD and the LOCK instruction all are unused.)

To ensure that changes of the TIN input signal state will be detected correctly, make sure the TIN input signal is held active for a duration of more than  $7t_c$  (BCLK)/2. (For details, see Section 23.9, "AC Characteristics (when VCCE = 5 V)," and Section 23.10, "AC Characteristics (when VCCE = 3.3 V).")

### 9.3.4 DMA Channel Priority

DMA0 has the highest priority. The priority of this and other channels is shown below.

DMA0 > DMA1 > DMA2 > DMA3 > DMA4 > DMA5 > DMA6 > DMA7 > DMA8 > DMA9

This order of priority is fixed and cannot be changed. Among channels on which DMA transfer is requested, the channel that has the highest priority is selected.

### 9.3.5 Gaining and Releasing Control of the Internal Bus

For any channel, control of the internal bus is gained and released in "single transfer DMA" mode. In single transfer DMA, the DMAC gains control of the internal bus (in one peripheral clock cycle) when DMA transfer request is accepted and after executing one DMA transfer (in one read and one write peripheral clock cycle), returns bus control to the CPU. The diagram below shows the operation in single transfer DMA.

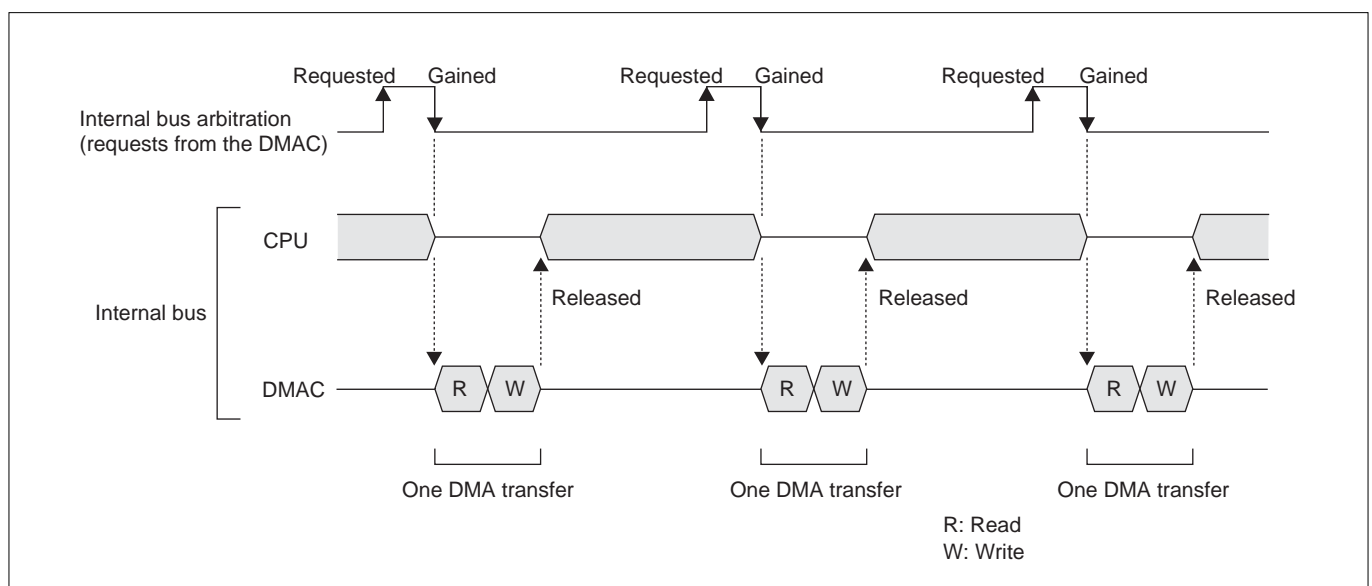


Figure 9.3.2 Gaining and Releasing Control of the Internal Bus

### 9.3.6 Transfer Units

Use the TSZSL (DMA transfer size select) bit to set for each channel the number of bits (8 or 16 bits) to be transferred in one DMA transfer.

### 9.3.7 Transfer Counts

Use the DMA Transfer Count Register to set transfer counts for each channel. Transfer can be performed up to 65,536 times. The value of the DMA Transfer Count Register is decremented by one every time one transfer unit is transferred. In ring buffer mode, the DMA Transfer Count Register operates in free-run mode, with the value set in it ignored.

### 9.3.8 Address Space

The address space in which data can be transferred by DMA is 64 Kbytes × 3 banks of SFR area or internal RAM area (32192 : H'0080 0000 to H'0082 FFFF, 32195 : H'0080 0000 to H'0080 BFFF, 32196 : H'0080 0000 to H'0081 3FFF) for both source and destination. To set the source and destination addresses on each DMA channel, use the DMA Source Address Register and DMA Destination Address Register. Note that no transfer over the bank is carried out. Upon completion of bank transfer to the final address, the bank is to be transferred to the head address.

### 9.3.9 Transfer Operation

#### (1) Dual-address transfer

Irrespective of the size of transfer unit, data is transferred in two bus cycles, one for source read access and the other for destination write access. (The transfer data is taken into the DMAC's internal temporary register before being transferred.)

#### (2) Bus protocol and bus timing

Because the bus interface is shared with the CPU, DMA transfer is performed with the same bus protocol and the same bus timing as when peripheral modules are accessed by the CPU.

#### (3) Transfer rate

Transfer is performed using a total of three peripheral clock cycles, one cycle to gain control of the bus and one read and one write cycles to perform one transfer. Therefore, the maximum transfer rate is calculated by the equation below:

$$\text{Maximum transfer rate [bytes per second]} = 2 \text{ bytes} \times \frac{1}{1/f(\text{BCLK}) \times 3 \text{ cycles}}$$

#### (4) Address count direction and address changes

The direction in which the source and destination addresses are counted as transfer proceeds ("Address fixed" or "Address incremental") is set for each channel using the SADSLS (source address direction select) and DADSLS (destination address direction select) bits.

When the transfer size is 16 bits, the address is incremented by two for each DMA transfer performed; when the transfer size is 8 bits, the address is incremented by one.

**Table 9.3.11 Address Count Direction and Address Changes**

Address Count Direction	Transfer Unit	Address Change for One DMA
Address fixed	8 bits	0
	16 bits	0
Address incremental	8 bits	+1
	16 bits	+2

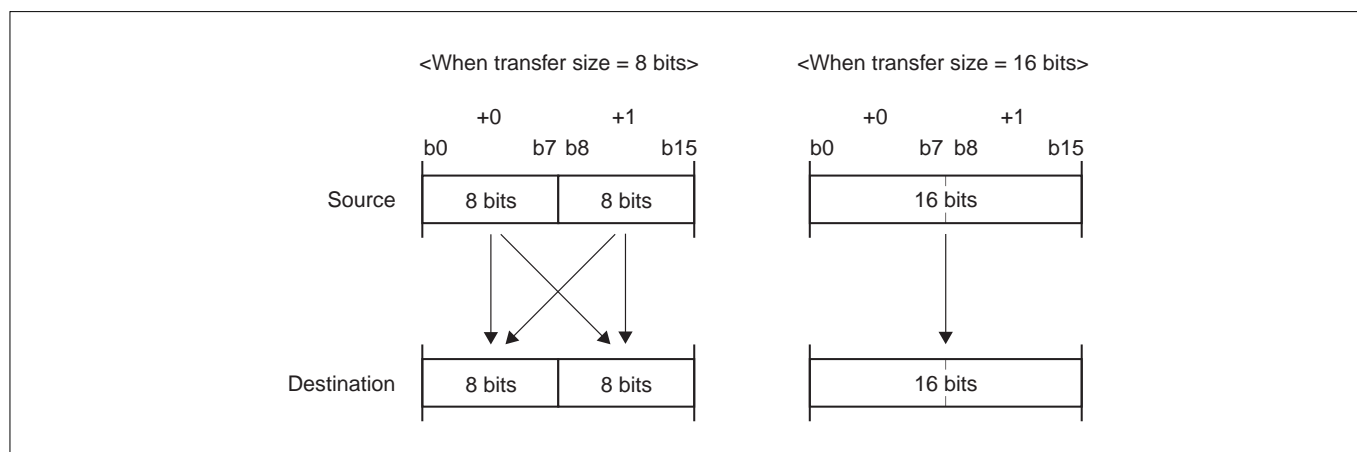
**(5) Transfer count value**

The transfer count value is decremented one at a time, irrespective of the size of transfer unit (8 or 16 bits).

**(6) Transfer byte positions**

When the transfer unit is 8 bits, the LSB of the address register is effective for both source and destination. (Therefore, in addition to data transfers between even addresses or between odd addresses, data may be transferred from even address to odd address or vice versa.) When the transfer unit is 16 bits, the LSB of the address register (= bit 15) is ignored, and data are always transferred in two bytes aligned to the 16-bit bus.

The diagram below shows the valid byte positions in DMA transfer.



**Figure 9.3.3 Transfer Byte Positions**

**(7) Ring buffer mode**

In the ring buffer mode, the number of DMA transfers to each channel can be selected from among 32, 16, 8, 4 and 2 times, and after transfer from the transfer start address, the bit returns to the transfer start address again: thus, the same operation is repeated by the selected frequency.

Note: • The transfer start address must be as follows:

	Transfer Size: 8 bits	Transfer Size: 16 bits
32-time ring buffer mode	Low order 5 bits – B'00000	Low order 6 bits – B'000000
16-time ring buffer mode	Low order 4 bits – B'0000	Low order 5 bits – B'00000
8-time ring buffer mode	Low order 3 bits – B'000	Low order 4 bits – B'0000
4-time ring buffer mode	Low order 2 bits – B'00	Low order 3 bits – B'000
2-time ring buffer mode	Low order 1 bits – B'0	Low order 2 bits – B'00

The address increment operation in the ring buffer mode is as follows.

**[1] When the transfer size is 8 bits**

The 27 high-order bits of the transfer start address are fixed, and the five low-order bits are incremented by one at a time. When as transfer proceeds the five low-order bits reach B'11111, they are recycled to B'00000 by the next increment operation, thus returning to the start address again.

**[2] When the transfer size is 16 bits**

The 26 high-order bits of the transfer start address are fixed, and the six low-order bits are incremented by two at a time. When as transfer proceeds the six low-order bits reach B'111110, they are recycled to B'000000 by the next increment operation, thus returning to the start address again.

If the source address has been set to be incremented, it is the source address that recycles to the start address; if the destination address has been set to be incremented, it is the destination address that recycles to the start address. If both source and destination addresses have been set to be incremented, both addresses recycle to the start address. However, the start address on either side must have their five low-order bits initially set to B'00000 (if transfer size = 16 bits, the six low-order bits must be B'000000).

During ring buffer mode, the transfer count register is ignored. Once DMA operation starts, the counter operates in free-run mode, and the transfer continues until the transfer enable bit is cleared to "0" (to disable transfer).

<When transfer size = 8 bits>		<When transfer size = 16 bits>	
Transfer count	Transfer address	Transfer count	Transfer address
1	H'0080 1000	1	H'0080 1000
2	H'0080 1001	2	H'0080 1002
3	H'0080 1002	3	H'0080 1004
31	H'0080 101E	31	H'0080 103C
32	H'0080 101F	32	H'0080 103E
↓	↓	↓	↓
1	H'0080 1000	1	H'0080 1000
2	H'0080 1001	2	H'0080 1002

Figure 9.3.4 Example of How Addresses Are Incremented in 32-channel Ring Buffer Mode

### 9.3.10 End of DMA and Interrupt

In normal mode, DMA transfer is terminated by an underflow of the transfer count register. When transfer finishes, the transfer enable bit is cleared to "0" and transfers are thereby disabled. Also, an interrupt request is generated at completion of transfer. However, if interrupt requests on any channel have been masked by the DMA Interrupt Request Mask Register, no interrupt requests are generated on that channel.

During ring buffer mode, the transfer count register operates in free-run mode, and transfer continues until the transfer enable bit is cleared to "0" (to disable transfer). In this case, therefore, no interrupt requests are generated at completion of DMA transfer. Nor are these DMA transfer-completed interrupt requests generated even when transfer in ring buffer mode is terminated by clearing the transfer enable bit.

### 9.3.11 Each Register Status after Completion of DMA Transfer

When DMA transfer is completed, the status of the source and destination address registers becomes as follows:

#### (1) Address fixed

- The values set in the address registers before DMA transfer started remain intact (fixed).

#### (2) Address incremental

- For 8-bit transfer, the values of the address registers are the last transfer address + 1.
- For 16-bit transfer, the values of the address registers are the last transfer address + 2.

The transfer count register at completion of DMA transfer is in an underflow state (H'FFFF). Therefore, before another DMA transfer can be performed, the transfer count register must be set newly again, except when trying to perform transfers 65,536 times (H'FFFF).

## 9.4 Notes on the DMAC

### • About writing to the DMAC related registers

Because DMA transfer involves exchanging data via the internal bus, the DMAC related registers basically can only be accessed for write upon exiting the reset state or when transfer is disabled (transfer enable bit = "0"). When transfer is enabled, do not write to the DMAC related registers, except the DMA transfer enable bit, the transfer request flag, DMA interrupt related register and the DMA Transfer Count Register that is protected in hardware. This is a precaution necessary to ensure stable DMA operation.

The table below lists the registers that can or cannot be accessed for write.

**Table 9.4.1 DMAC Related Registers That Can or Cannot Be Accessed for Write**

Status	Transfer enable bit	Transfer request flag	DMA interrupt related register	Other DMAC related registers
Transfer enabled	Can be accessed	Can be accessed	Can be accessed	Cannot be accessed
Transfer disabled	Can be accessed	Can be accessed	Can be accessed	Can be accessed

Even for registers that can exceptionally be written to while transfer is enabled, the following conditions must be observed:

#### (1) DMA Channel Control Register 0 transfer enable bit and transfer request flag

For all bits other than transfer enable bit and transfer request flag in this register, be sure to write the same data that those bits had before the write. Note, however, that only writing "0" is effective for the transfer request flag.

#### (2) DMA Transfer Count Register

When transfer is enabled, this register is protected in hardware, so that any data rewritten to it is ignored.

#### (3) Rewriting the DMA source and DMA destination addresses on different channels by DMA transfer

Although this operation means accessing the DMAC related registers while DMA is enabled, there is no problem. Note, however, that no data can be transferred by DMA to the DMAC related registers on the currently active channel itself.

### • Manipulating the DMAC related registers by DMA transfer

When manipulating the DMAC related registers by means of DMA transfer (e.g., reloading the DMAC related registers with the initial values by DMA transfer), do not write to the DMAC related registers on the currently active channel through that channel. (If this precaution is neglected, device operation cannot be guaranteed.) It is only the DMAC related registers on other channels that can be rewritten by means of DMA transfer. (For example, the DMA Source Address and DMA Destination Address Registers on channel 1 can be rewritten by DMA transfer through channel 0.)

### • About the DMA Interrupt Request Status Register

When clearing the DMA Interrupt Request Status Register, be sure to write "1" to all bits, except those to be cleared. Writing "1" to any bits in this register has no effect, so that they retain the data they had before the write.

### • About the stable operation of DMA transfer

To ensure the stable operation of DMA transfer, never rewrite the DMAC related registers, except transfer enable bits of the DMA channel control register 0, unless transfer is disabled. One exception is that even when transfer is enabled, the DMA Source Address and DMA Destination Address Registers can be rewritten by DMA transfer from one channel to another.

This page is blank for reasons of layout.



## CHAPTER 10

---

# MULTIJUNCTION TIMERS

- 10.1 Outline of Multijunction Timers
- 10.2 Common Units of Multijunction Timers
- 10.3 TOP (Output-Related 16-Bit Timer)
- 10.4 TIO (Input/Output-Related 16-Bit Timer)
- 10.5 TMS (Input-Related 16-Bit Timer)
- 10.6 TML (Input-Related 32-Bit Timer)
- 10.7 TID (Input-Related 16-Bit Timer)
- 10.8 TOU (Output-Related 24-Bit Timer)

## 10.1 Outline of Multijunction Timers

The multijunction timers (abbreviated MJT) have input event and output event buses. Therefore, in addition to being used as a single unit, the timers can be internally connected to each other. This capability allows for highly flexible timer configuration, making it possible to meet various application needs. It is because the timers are connected to the internal event buses at multiple points that they are called the “multijunction” timers.

The 32192/32195/32196 has six types of MJT as listed in the table below, providing a total of 55-channel timers.

**Table 10.1.1 Outline of MJT**

Name	Type	No. of Channels	Description
TOP (Timer Output)	Output-related 16-bit timer (down-counter)	11	One of three output modes can be selected by software. <With correction function> <ul style="list-style-type: none"> <li>• Single-shot output mode</li> <li>• Delayed single-shot output mode</li> </ul> <Without correction function> <ul style="list-style-type: none"> <li>• Continuous output mode</li> </ul>
TIO (Timer Input Output)	Input/output-related 16-bit timer (down-counter)	10	One of three input modes or four output modes can be selected by software. <Input modes> <ul style="list-style-type: none"> <li>• Measure clear input mode</li> <li>• Measure free-run input mode</li> <li>• Noise processing input mode</li> </ul> <Output modes without correction function> <ul style="list-style-type: none"> <li>• PWM output mode</li> <li>• Single-shot output mode</li> <li>• Delayed single-shot output mode</li> <li>• Continuous output mode</li> </ul>
TMS (Timer Measure Small)	Input-related 16-bit timer (up-counter)	8	16-bit input measure timer
TML (Timer Measure Large)	Input-related 32-bit timer (up-counter)	8	32-bit input measure timer
TID (Timer Input Derivation)	Input-related 16-bit timer (up/down-counter)	2	One of four input modes can be selected by software. <ul style="list-style-type: none"> <li>• Fixed period mode</li> <li>• Event count mode</li> <li>• Multiply-by-4 event count mode</li> <li>• Up/down event count mode</li> </ul>
TOU (Timer Output Unification)	Output-related 24-bit timer (down-counter) (16-bit timer during PWM output and single-shot PWM output modes)	16	One of five output modes can be selected by software. <Without correction function> <ul style="list-style-type: none"> <li>• PWM output mode</li> <li>• Single-shot PWM output mode</li> <li>• Delayed single-shot output mode</li> <li>• Single-shot output mode</li> <li>• Continuous output mode</li> </ul>

Table 10.1.2 Interrupt Generation Functions of MJT

Signal Name	MJT Interrupt Request Source	Source of Interrupt	No. of ICU Input Sources
IRQ0	TIO0–3 output	MJT output interrupt 0	4
IRQ1	TOP6, TOP7 output	MJT output interrupt 1	2
IRQ2	TOP0–5 output	MJT output interrupt 2	6
IRQ3	TIO8, TIO9 output	MJT output interrupt 3	2
IRQ4	TIO4–7 output	MJT output interrupt 4	4
IRQ5	TOP10 output	MJT output interrupt 5	1
IRQ6	TOP8, TOP9 output	MJT output interrupt 6	2
IRQ7	TMS0, TMS1 output	MJT output interrupt 7	2
IRQ8	TIN7–TIN11 input	MJT input interrupt 0	5
IRQ9	TIN0 input	MJT input interrupt 1	1
IRQ10	TIN16–TIN19 input	MJT input interrupt 2	4
IRQ11	TIN20–TIN27 input	MJT input interrupt 3	8
IRQ12	TIN3–TIN6 input	MJT input interrupt 4	4
IRQ13	TOU0_0–TOU0_7 output	TOU0 output interrupt	8
IRQ14	TID0 output	TID0 output interrupt	1
IRQ15	TID1 output	TID1 output interrupt	1
IRQ16	TOU1_0–TOU1_7 output	TOU1 output interrupt	8
IRQ18	TIN30–TIN33 input	TML1 input interrupt	4

Table 10.1.3 DMA Transfer Request Generation by MJT

Corresponding DMAC Channel No.	DMA Transfer Request Source
DMA0	TIO8_udf
	Input event bus 2
	TID0_udf/ovf
	TOU1_0irq
	Common transfer request source (see Table 10.1.4)
DMA1	Output event bus 0
	TIN3 input signal
	TID1_udf/ovf
	TOU1_1irq
	Common transfer request source (see Table 10.1.4)
DMA2	Output event bus 1
	TIN18 input signal
	Common transfer request source (see Table 10.1.4)
DMA3	TIN0 input signal
	TOU1_6irq
	Common transfer request source (see Table 10.1.4)
DMA4	TIN19 input signal
	TOU1_7irq
	TIN7 input signal
	Common transfer request source (see Table 10.1.4)

DMA5	TIN20 input signal
	TOU0_0irq
	TIN8 input signal
	Common transfer request source (see Table 10.1.4)
DMA6	TOU0_1irq
	Common transfer request source (see Table 10.1.4)
DMA7	TOU0_2irq
	Common transfer request source (see Table 10.1.4)
DMA8	Input event bus 0
	TOU0_6irq
	Common transfer request source (see Table 10.1.4)
DMA9	TOU0_7irq
	Common transfer request source (see Table 10.1.4)

**Table 10.1.4 DMA Transfer Request Generation by MJT (Common)**

Corresponding DMAC Channel No.	DMA Transfer Request Source
DMA <sub>n</sub>	Input event bus 1
	Input event bus 3
	Output event bus 2
	Output event bus 3
	TIN0 input signal
	TIN30 input signal
	TIO8_udf
	TIO9_udf

**Table 10.1.5 A/D Conversion Start Request by MJT**

Signal Name	A/D Conversion Start Request Source	A/D Converter
AD0TRG	Input event bus 2, input event bus 3, output event bus 3, TIN23	Can be input to A/D0 conversion start trigger

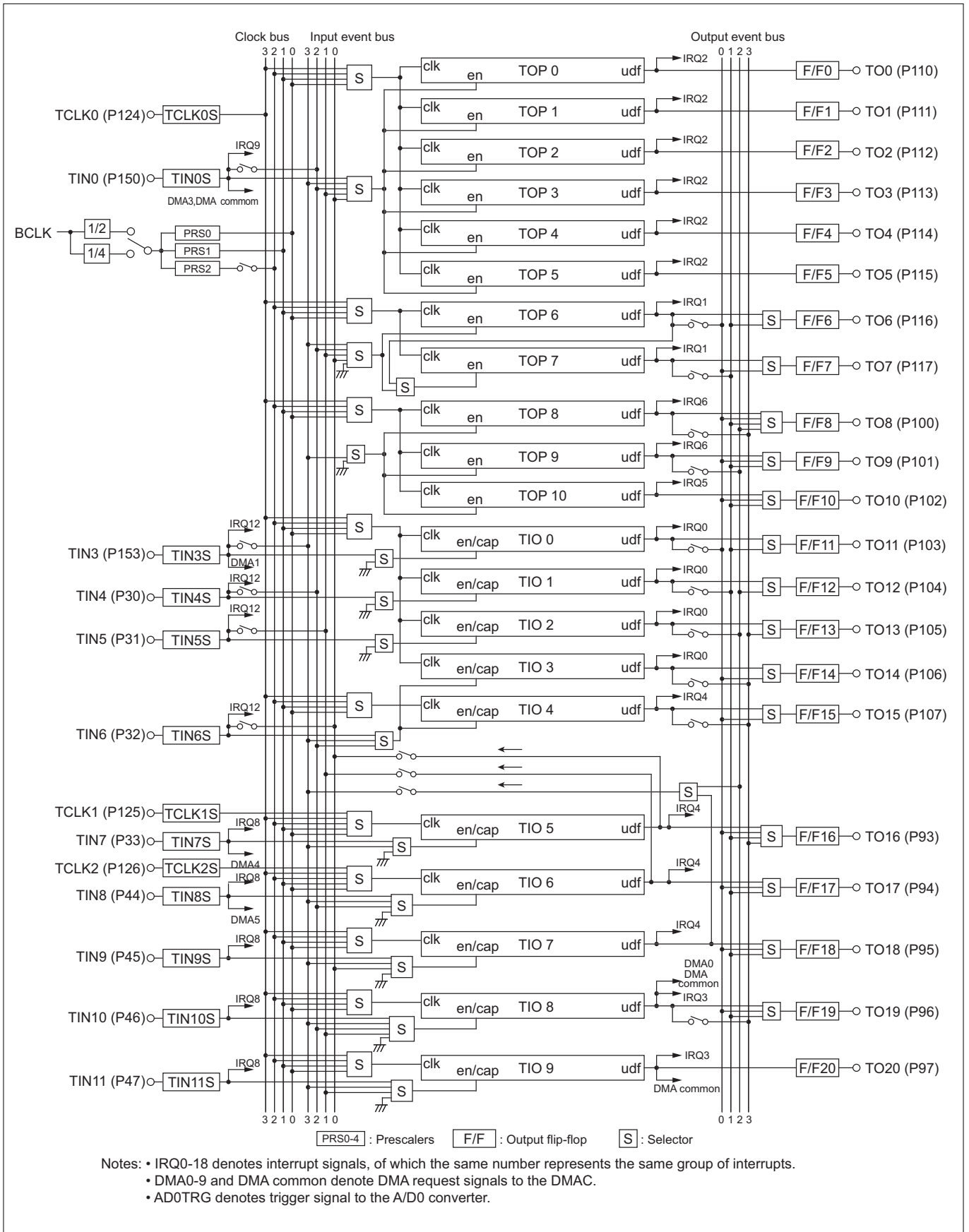


Figure 10.1.1 Block Diagram of MJT (1/4)

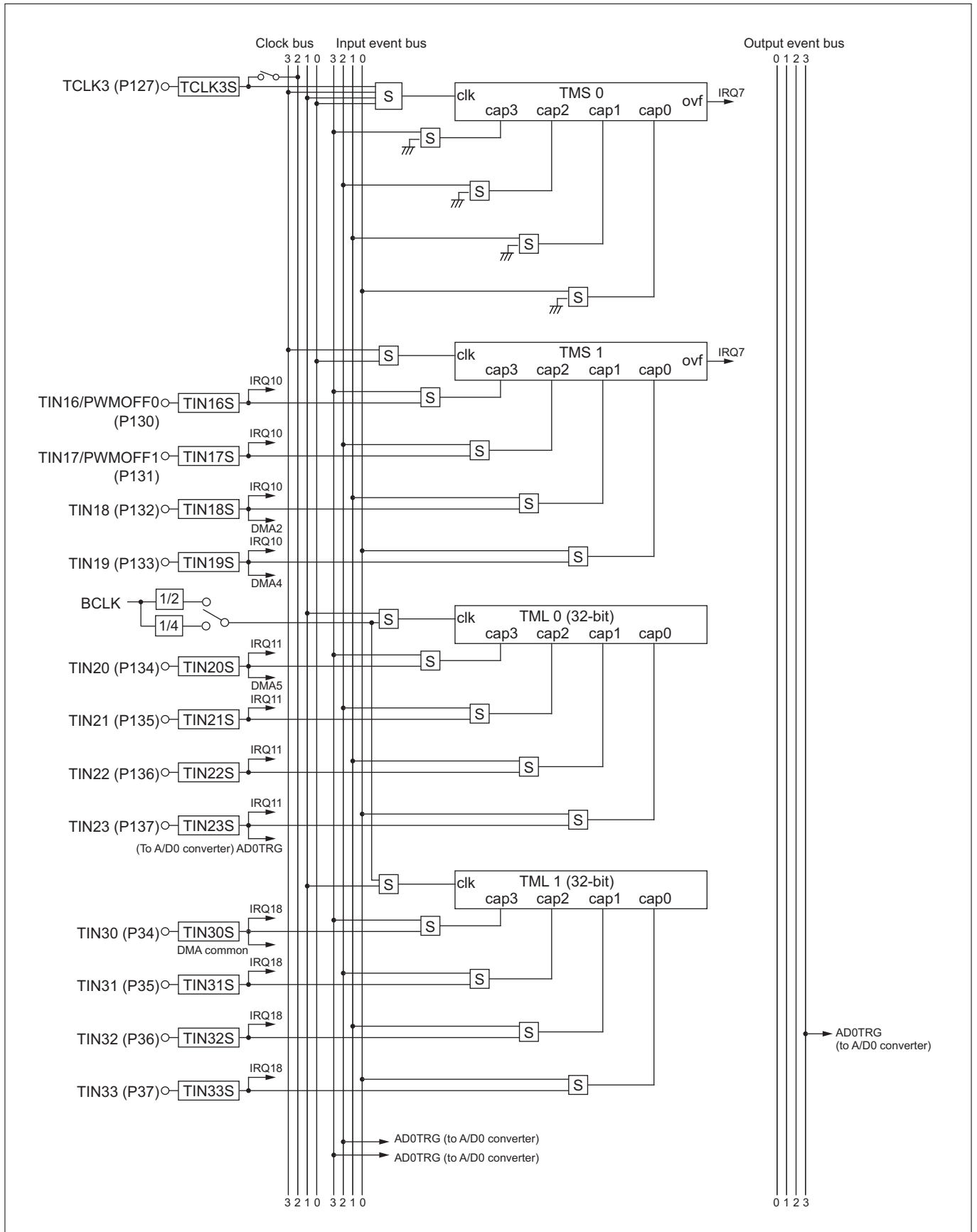


Figure 10.1.2 Block Diagram of MJT (2/4)

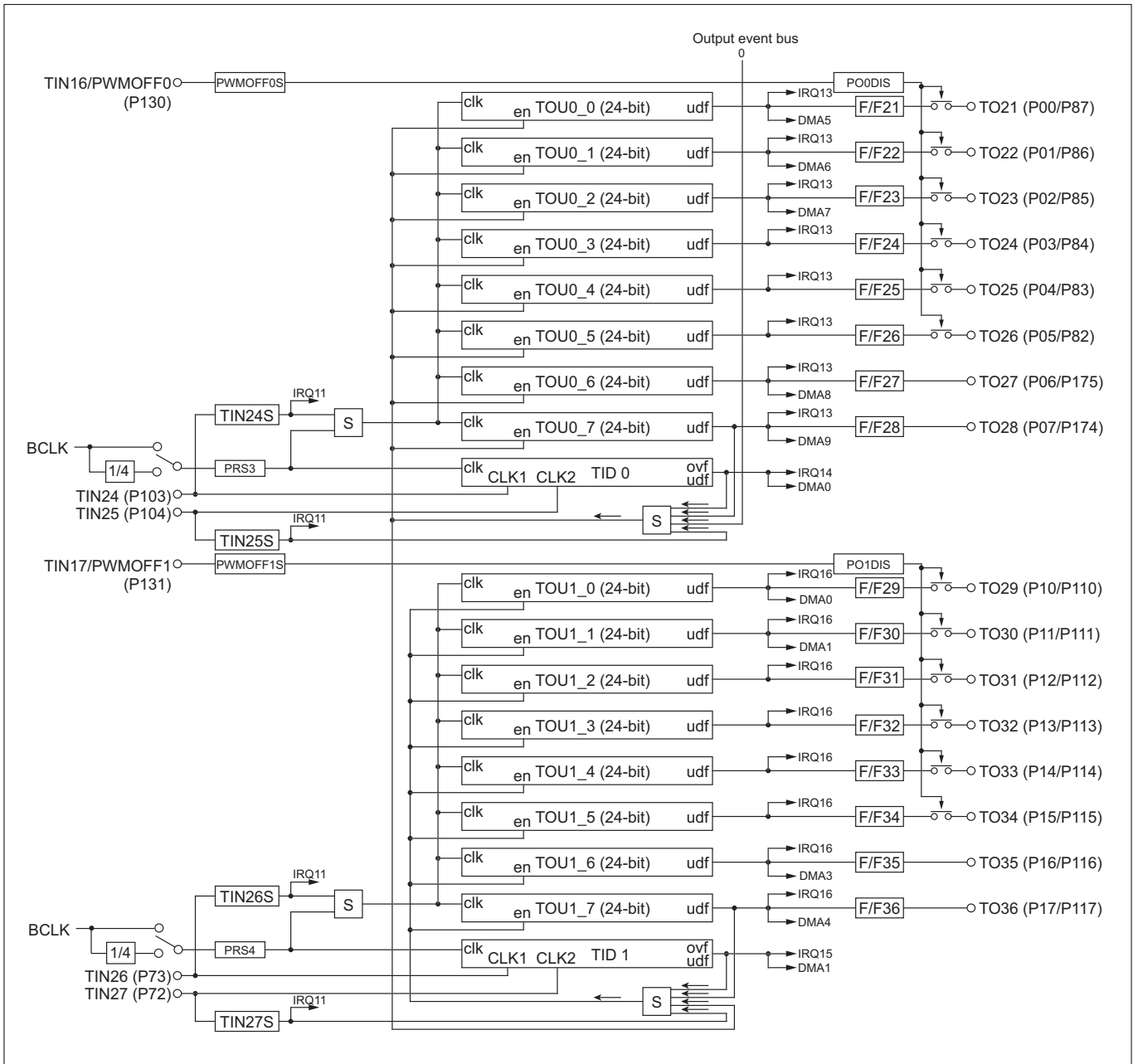
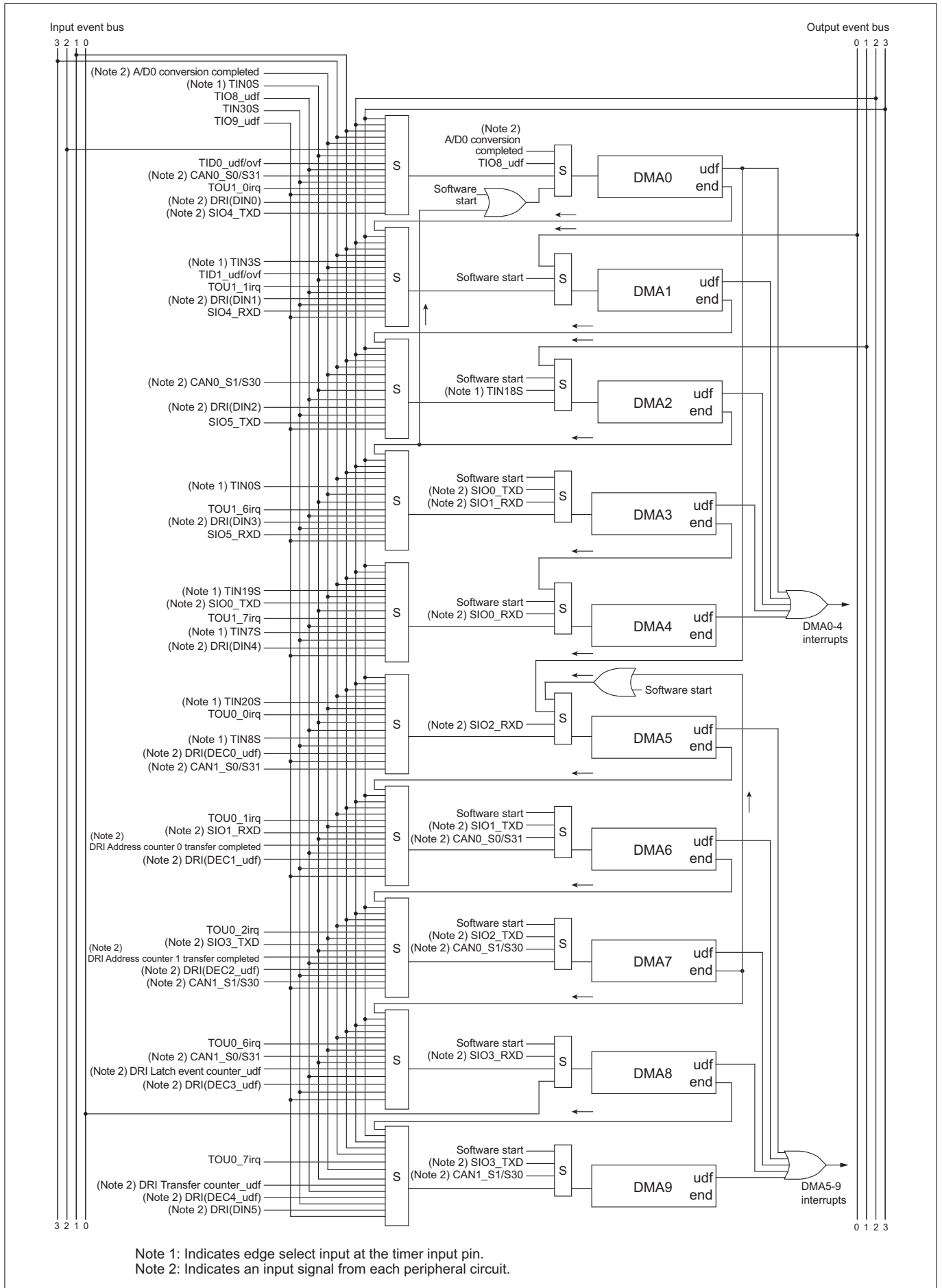


Figure 10.1.3 Block Diagram of MJT (3/4)



**Figure 10.1.4 Block Diagram of MJT (4/4)**



## 10.2 Common Units of Multijunction Timers

The common units of MJT include the following:

- Prescaler Unit
- Clock Bus and Input/Output Event Bus Control Unit
- Input Processing Control Unit
- Output Flip-flop Control Unit
- Interrupt Control Unit

## 10.2.1 MJT Common Unit Register Map

The table below shows a common unit register map of MJT.

MJT Common Unit Register Map (1/2)

Address	+0 address	+1 address	See pages
	b0	b7 b8	b15
H'0080 0200	Common Count Clock Select Register (CNTCKSEL)	Clock Bus & Input Event Bus Control Register (CKIEBCR)	10-12 10-17
H'0080 0202	Prescaler Register 0 (PRS0)	Prescaler Register 1 (PRS1)	10-13
H'0080 0204	Prescaler Register 2 (PRS2)	Output Event Bus Control Register (OEBCR)	10-13 10-18
	(Use inhibited area)		
H'0080 0210	TCLK Input Processing Control Register (TCLKCR)		10-21
H'0080 0212	TIN Input Processing Control Register 0 (TINCR0)		10-22
H'0080 0214	TIN Input Processing Control Register 1 (TINCR1)		10-23
H'0080 0216	TIN Input Processing Control Register 2 (TINCR2)		10-24
H'0080 0218	TIN Input Processing Control Register 3 (TINCR3)		10-25
H'0080 021A	TIN Input Processing Control Register 4 (TINCR4)		10-25
	(Use inhibited area)		
H'0080 0220	F/F Source Select Register 0 (FFS0)		10-28
H'0080 0222	(Use inhibited area)	F/F Source Select Register 1 (FFS1)	10-29
H'0080 0224	F/F Protect Register 0 (FFP0)		10-30
H'0080 0226	F/F Data Register 0 (FFD0)		10-32
H'0080 0228	(Use inhibited area)	F/F Protect Register 1 (FFP1)	10-30
H'0080 022A	(Use inhibited area)	F/F Data Register 1 (FFD1)	10-32
	(Use inhibited area)		
H'0080 0230	TOP Interrupt Control Register 0 (TOPIR0)	TOP Interrupt Control Register 1 (TOPIR1)	10-38
H'0080 0232	TOP Interrupt Control Register 2 (TOPIR2)	TOP Interrupt Control Register 3 (TOPIR3)	10-40 10-41
H'0080 0234	TIO Interrupt Control Register 0 (TIOIR0)	TIO Interrupt Control Register 1 (TIOIR1)	10-42 10-43
H'0080 0236	TIO Interrupt Control Register 2 (TIOIR2)	TMS Interrupt Control Register (TMSIR)	10-44 10-45
H'0080 0238	TIN Interrupt Control Register 0 (TINIR0)	TIN Interrupt Control Register 1 (TINIR1)	10-46 10-47
H'0080 023A	TIN Interrupt Control Register 2 (TINIR2)	TIN Interrupt Control Register 3 (TINIR3)	10-48
H'0080 023C	TIN Interrupt Control Register 4 (TINIR4)	TIN Interrupt Control Register 5 (TINIR5)	10-50
H'0080 023E	TIN Interrupt Control Register 6 (TINIR6)	TIN Interrupt Control Register 7 (TINIR7)	10-52 10-55
	(Use inhibited area)		
H'0080 07D0	Prescaler Register 3 (PRS3)		10-13
H'0080 07D2	TOU0 Interrupt Request Mask Register (TOU0IMA)	TOU0 Interrupt Request Status Register (TOU0IST)	10-56
H'0080 07D4		F/F21-28 Protect Register (FF2128P)	10-31
H'0080 07D6		F/F21-28 Data Register (FF2128D)	10-33
	(Use inhibited area)		

## MJT Common Unit Register Map (2/2)

Address	+0 address		+1 address		See pages
	b0	b7	b8	b15	
H'0080 07E0			TIN24,25 Input Processing Control Register (TIN2425CR)		10-26
H'0080 07E2	TIN24,25 Interrupt Request Mask Register (TIN2425IMA)		TIN24,25 Interrupt Request Status Register (TIN2425IST)		10-52
H'0080 0BD0	Prescaler Register 4 (PRS4)				10-13
H'0080 0BD2	TOU1 Interrupt Request Mask Register (TOU1IMA)		TOU1 Interrupt Request Status Register (TOU1IST)		10-58
H'0080 0BD4			F/F29-36 Protect Register (FF2936P)		10-31
H'0080 0BD6			F/F29-36 Data Register (FF2936D)		10-33
H'0080 0BE0			TIN26,27 Input Processing Control Register (TIN2627CR)		10-26
H'0080 0BE2	TIN26,27 Interrupt Request Mask Register (TIN2627IMA)		TIN26,27 Interrupt Request Status Register (TIN2627IST)		10-53

#### 10.2.2 Common Count Clock Select Function

Common Count Clock Select Register (CNTCKSEL)

<Address: H'0080 0200>

b0	1	2	3	4	5	6	b7
PRS012CKS	0	0	0	0	0	0	0

<Upon exiting reset: H'00>

b	Bit Name	Function	R	W
0	PRS012CKS	0: BCLK/4 Prescaler 0-2, TML0,1 supplied clock select bit	R	W
1-7	No function assigned. Fix to "0."		0	0

Note 1: Clock switchover takes effect asynchronously with the count clock. This bit can only be set or reset before the prescalers 0, 1, 2 and the TML0, 1 counters are set when the TOP/TIO/TMS are inactive.

This register is used to select the clock supplied to the prescalers 0–2 and the timers (TML0, 1).

##### (1) PRS012CKS (prescaler 0-2, TML0,1 supplied clock select) bit (Bit 0)

This bit selects the clock supplied to the prescalers 0–2 and the timers TML0 and 1. Setting this bit to "0" selects BCLK/4 (10 MHz when  $f(\text{CPUCLK}) = 160 \text{ MHz}$ ); setting this bit to "1" selects BCLK/2 (20 MHz when  $f(\text{CPUCLK}) = 160 \text{ MHz}$ ).

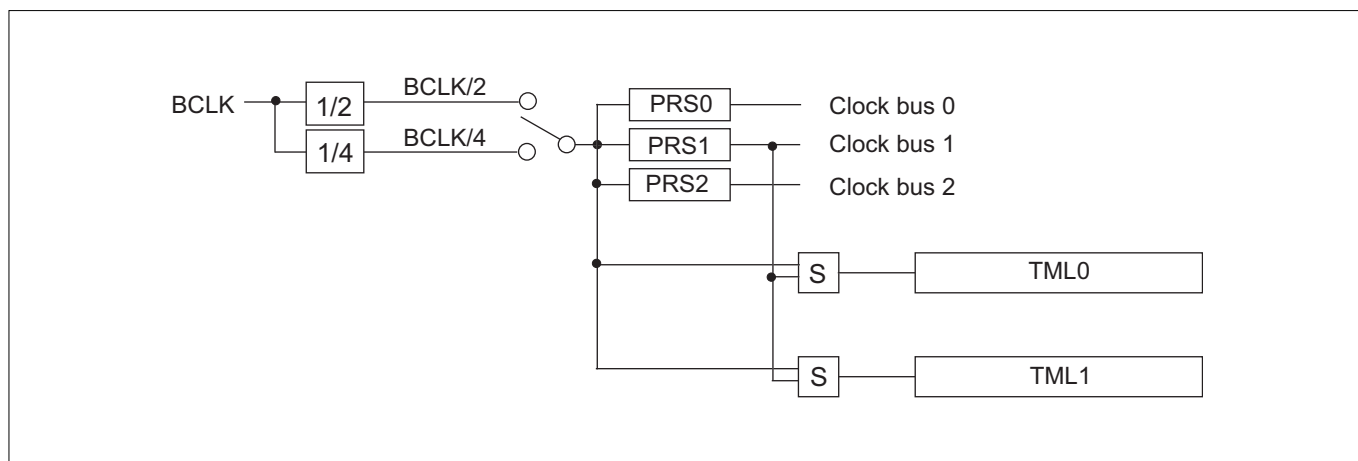


Figure 10.2.1 Block Diagram of the Common Count Clock Select Function

#### 10.2.3 Prescaler Unit

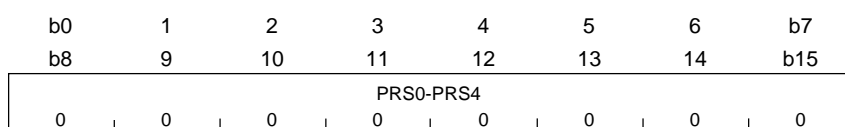
The Prescalers PRS0 to 2 are an 8-bit counter, which generates clocks supplied to each timer (TOP, TIO, TMS, TML) from the internal peripheral clock (BCLK) divided by 2 or 4.

The Prescalers PRS3 and 4 are an 8-bit counter, which generates clocks supplied to timerTID and TOU from the internal peripheral clock BCLK or BCLK divided by 4.

The values of prescaler registers are initialized to H'00 upon exiting the reset state. When the set value of any prescaler register is rewritten, the prescaler starts operating with the new value at the same time it has underflowed. Values H'00 to H'FF can be set in the prescaler register. The prescaler's divide-by ratio is given by the equation below:

$$\text{Prescaler divide-by ratio} = \frac{1}{\text{prescaler set value} + 1}$$

Prescaler Register 0 (PRS0)	<Address: H'0080 0202>
Prescaler Register 1 (PRS1)	<Address: H'0080 0203>
Prescaler Register 2 (PRS2)	<Address: H'0080 0204>
Prescaler Register 3 (PRS3)	<Address: H'0080 07D0>
Prescaler Register 4 (PRS4)	<Address: H'0080 0BD0>



<Upon exiting reset: H'00>

b	Bit Name	Function	R	W
0-7	PRS0-PRS4	Set the prescaler divide-by value	R	W
(8-15)	Prescaler			

Prescaler Registers 0-2 start counting after exiting the reset state. Prescaler Registers 3, 4 each are activated by setting the TID0 Control & Prescaler 3 Enable Register (TID0PRS3EN) or TID1 Control & Prescaler 4 Enable Register (TID1PRS4EN) prescaler-n enable (PRSnEN) bit to "1" (count start), upon which the prescaler register value is reloaded and the prescaler starts counting. For details, see Section 10.7, "TID (Input-Related 16-Bit Timer)."

If the prescaler register is accessed for read during operation, the value written into it, not the current count, is read out.

### 10.2.4 Clock Bus and Input/Output Event Bus Control Unit

#### (1) Clock bus

The clock bus is provided for supplying clock to each timer, and is comprised of four lines of clock bus 0–3. Each timer can use these clock bus signals as clock input signals. The table below lists the signals that can be fed into the clock bus.

**Table 10.2.1 Acceptable Clock Bus Signals**

Clock Bus	Acceptable Signal
3	TCLK0 input
2	Internal prescaler (PRS2) or TCLK3 input
1	Internal prescaler (PRS1)
0	Internal prescaler (PRS0)

#### (2) Input event bus

The input event bus is provided for supplying a count enable signal or measure capture signal to each timer, and is comprised of four lines of input event bus 0–3. Each timer can use these input event bus signals as enable (or capture) input. Furthermore, they can also be used as request signals to start A/D conversion or DMA transfer.

The table below lists the signals that can be fed into the input event bus.

**Table 10.2.2 Connectable (Acceptable) Input Event Bus Signals**

Input Event Bus	Connectable (Acceptable) Signal (Note 1)
3	TIN3 input, output event bus 2 or TIO7 underflow signal
2	TIN0 input or TIN4 input
1	TIO6 underflow signal, TIN5 input
0	TIO5 underflow signal, TIN6 input

Note 1: For the destination (output) to which the input event bus signals are connected, see Figure 10.1.1, “Block Diagram of MJT.”

#### (3) Output event bus

The output event bus has the underflow signal from each timer connected to it, and is comprised of four lines of output event bus 0–3. Output event bus signals are connected to output flip-flops, and can also be connected to the A/D converter and DMAC. Furthermore, output event bus 2 can be connected to input event bus 3.

The table below lists the signals that can be connected to the output event bus.

**Table 10.2.3 Connectable (Acceptable) Output Event Bus Signals**

Output Event Bus	Connectable (Acceptable) Signal (Note 1)
3	TOP8, TIO3, TIO4 or TIO8 underflow signal
2	TOP9 or TIO2 underflow signal
1	TOP7 or TIO1 underflow signal
0	TOP6 or TIO0 underflow signal

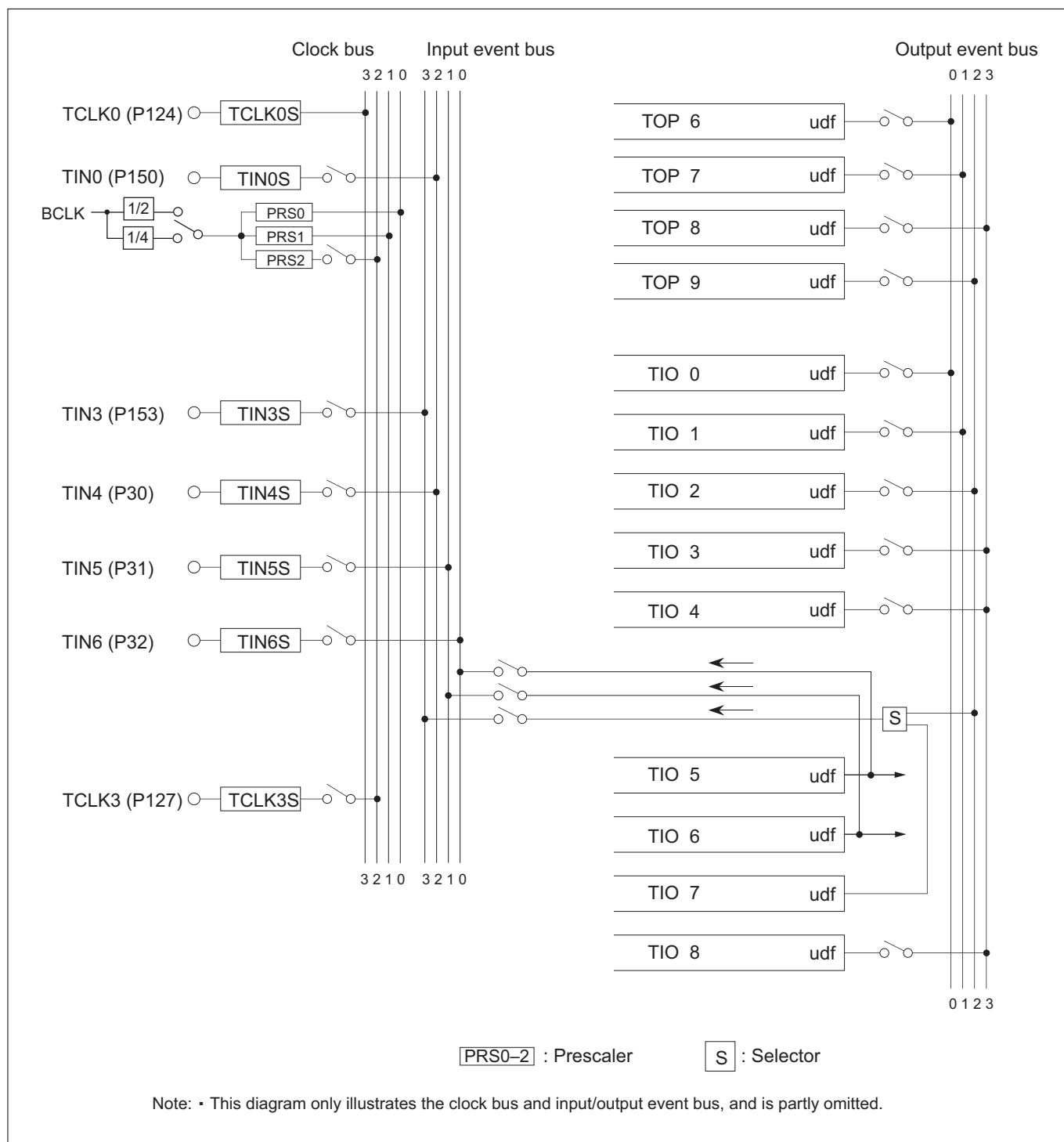
Note 1: For the destination (output) to which the output event bus signals are connected, see Figure 10.1.1, “Block Diagram of MJT.”

Note that the signals from each timer to the output event bus (and TIO5, 6 signals to the input event bus) are generated with the timing shown in Table 10.2.4, and not the timing at which signals are output from the timer to the output flip-flop.

**Table 10.2.4 Timing at Which Signals are Generated to the Output Event Bus by Each Timer**

Timer	Mode	Timing at which signals are generated to the output event bus
TOP	Single-shot output mode	When the counter underflows
	Delayed single-shot output mode	When the counter underflows
	Continuous output mode	When the counter underflows
TIO(Note 1)	Measure clear input mode	When the counter underflows
	Measure free-run input mode	When the counter underflows
	Noise processing input mode	When the counter underflows
	PWM output mode	When the counter underflows
	Single-shot output mode	When the counter underflows
	Delayed single-shot output mode	When the counter underflows
	Continuous output mode	When the counter underflows
TMS	(16-bit measure input)	No signals generated
TML	(32-bit measure input)	No signals generated
TID	Fixed period mode	No signals generated
	Event count mode	No signals generated
	Multiply-by-4 event count mode	No signals generated
	Up/down event count mode	No signals generated
TOU	PWM output mode	No signals generated
	Single-shot PWM mode	No signals generated
	Delayed single-shot output mode	No signals generated
	Single-shot output mode	No signals generated
	Continuous output mode	No signals generated

Note 1: TIO5–7 output an underflow signal to the input event bus.



**Figure 10.2.2 Conceptual Diagram of the Clock Bus and Input/Output Event Bus**



The Clock Bus and Input/Output Event Bus Control Unit has the following registers:

- Clock Bus & Input Event Bus Control Register (CKIEBCR)
- Output Event Bus Control Register (OEBCR)

Clock Bus & Input Event Bus Control Register (CKIEBCR)

<Address: H'0080 0201>

b8	9	10	11	12	13	14	b15
IEB3S		IEB2S		IEB1S	IEB0S		CKB2S
0	0	0	0	0	0	0	0

<Upon exiting reset: H'00>

b	Bit Name	Function	R	W
8, 9	IEB3S Input event bus 3 input select bit	00: Select external input 3 (TIN3) 01: Select external input 3 (TIN3) 10: Select output event bus 2 11: Select TIO7 output	R	W
10, 11	IEB2S Input event bus 2 input select bit	00: Select external input 0 (TIN0) 01: Does not use input event bus 2 10: Select external input 4 (TIN4) 11: Select external input 4 (TIN4)	R	W
12	IEB1S Input event bus 1 input select bit	0: Select external input 5 (TIN5) 1: Select TIO6 output	R	W
13	IEB0S Input event bus 0 input select bit	0: Select external input 6 (TIN6) 1: Select TIO5 output	R	W
14	No function assigned. Fix to "0."		0	0
15	CKB2S Clock bus 2 input select bit	0: Select prescaler 2 1: Select external clock 3 (TCLK3)	R	W

The CKIEBCR register is used to select the clock source (external input or prescaler) supplied to the clock bus and the count enable/capture signal (external input or output event bus) supplied to the input event bus.

Output Event Bus Control Register (OEBCR)

&lt;Address: H'0080 0205&gt;

b8	9	10	11	12	13	14	b15
OEB3S			OEB2S		OEB1S		OEB0S
0	0	0	0	0	0	0	0

&lt;Upon exiting reset: H'00&gt;

b	Bit Name	Function	R	W
8, 9	OEB3S Output event bus 3 input select bit	00: Select TOP8 output 01: Select TIO3 output 10: Select TIO4 output 11: Select TIO8 output	R	W
10	No function assigned. Fix to "0."		0	0
11	OEB2S Output event bus 2 input select bit	0: Select TOP9 output 1: Select TIO2 output	R	W
12	No function assigned. Fix to "0."		0	0
13	OEB1S Output event bus 1 input select bit	0: Select TOP7 output 1: Select TIO1 output	R	W
14	No function assigned. Fix to "0."		0	0
15	OEB0S Output event bus 0 input select bit	0: Select TOP6 output 1: Select TIO0 output	R	W

The OEBCR register is used to select the timer (TOP or TIO) whose underflow signal is supplied to the output event bus.

### 10.2.5 Input Processing Control Unit

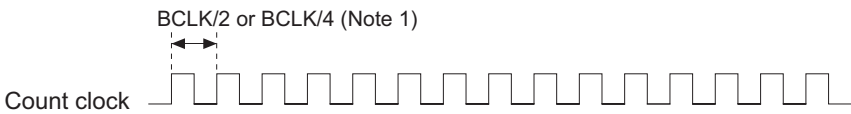
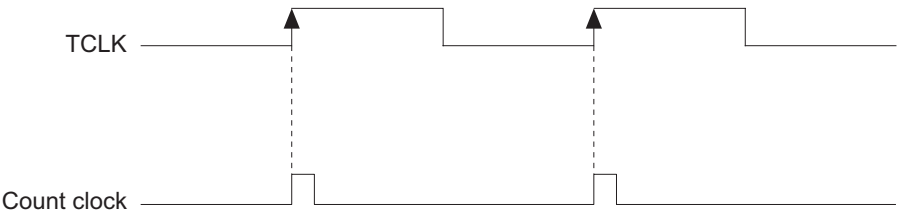
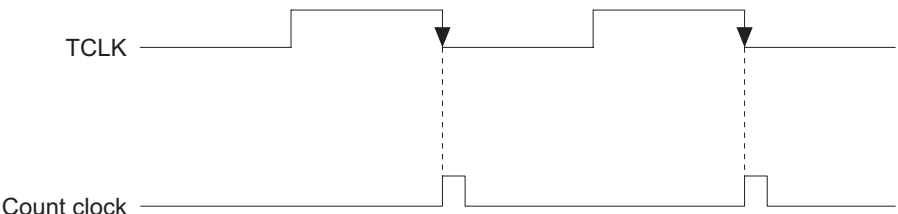
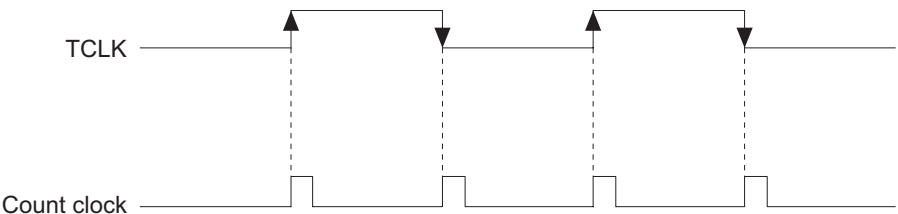
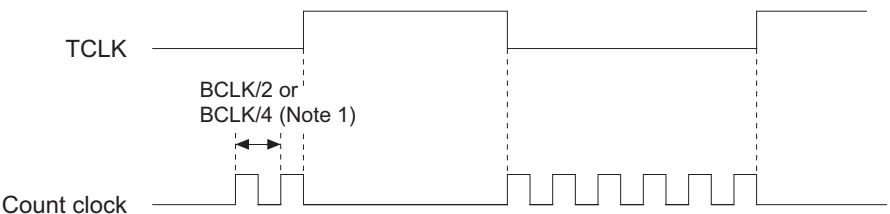
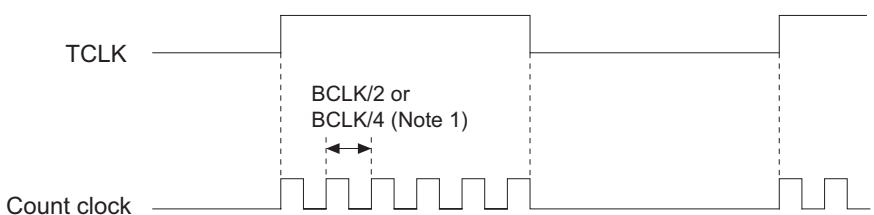
The Input Processing Control Unit processes TCLK and TIN input signals to the MJT. In TCLK input processing, it selects the source of TCLK signal, and for external input, it selects the active edge (rising or falling or both) or level ("H" or "L") of the signal, at which to generate the clock signal supplied to the clock bus.

In TIN input processing, the unit selects the active edge (rising or falling or both) or level ("H" or "L") of the signal, at which to generate the enable, measure or count source signal for each timer or the signal supplied to each event bus.

Following input processing registers are included:

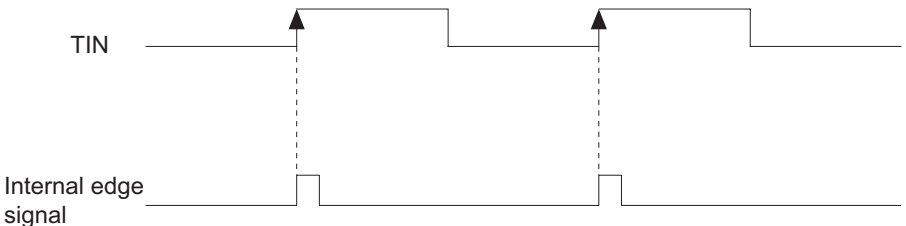
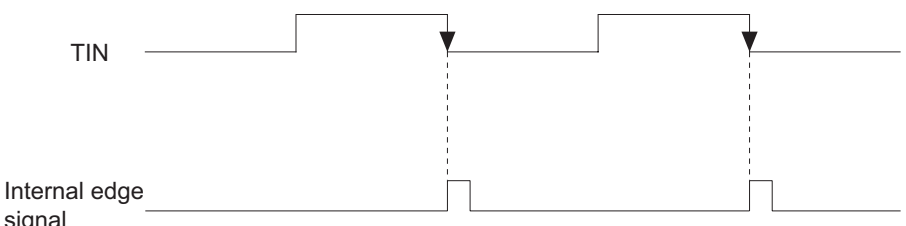
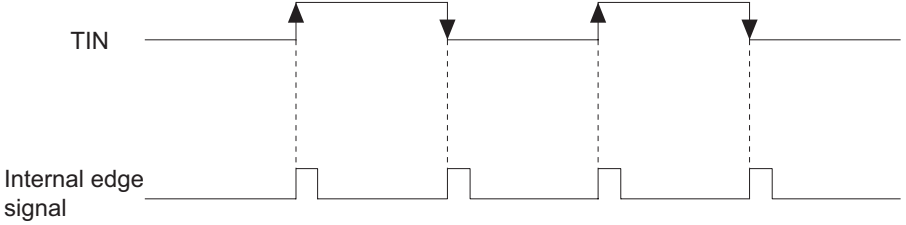
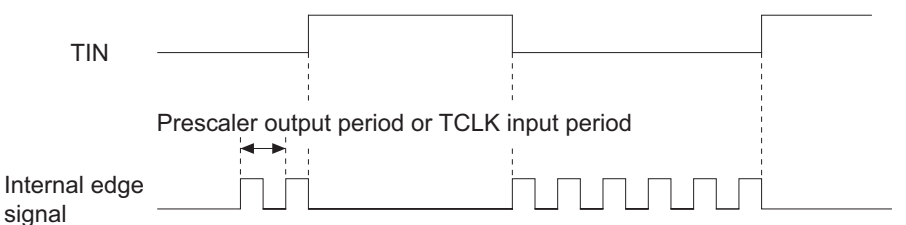
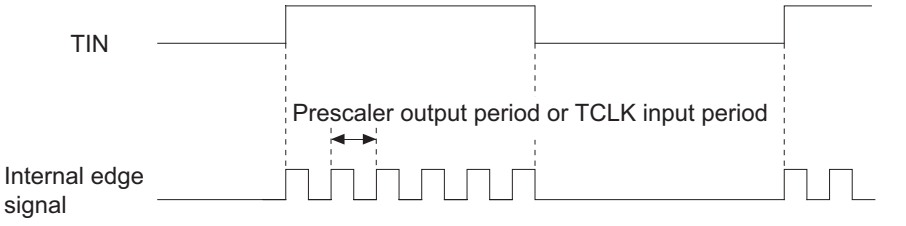
- TCLK Input Processing Control Register (TCLKCR)
- TIN Input Processing Control Register 0 (TINCR0)
- TIN Input Processing Control Register 1 (TINCR1)
- TIN Input Processing Control Register 2 (TINCR2)
- TIN Input Processing Control Register 3 (TINCR3)
- TIN Input Processing Control Register 4 (TINCR4)
- TIN24,25 Input Processing Control Register (TIN2425CR)
- TIN26,27 Input Processing Control Register (TIN2627CR)

#### (1) Functions of TCLK Input Processing Control Registers

Item	Function
BCLK/2 or BCLK/4 (Note 1)	
Rising edge	
Falling edge	
Both edges	
"L" level	
"H" level	

Note 1: To select BCLK/2 or BCLK/4, use the PRS012CKS (prescaler 0-2, TML0,1 supplied clock select) bit of the Common Count Clock Select Register (CNTCKSEL).  
For details, refer to Section 10.2.2, "Common Count Clock Select Function."

#### (2) Functions of TIN Input Processing Control Registers

Item	Function
Rising edge	 <p>The diagram shows two rising edges on the TIN signal. Vertical dashed lines mark the rising edges. The internal edge signal shows a single narrow pulse for each rising edge.</p>
Falling edge	 <p>The diagram shows two falling edges on the TIN signal. Vertical dashed lines mark the falling edges. The internal edge signal shows a single narrow pulse for each falling edge.</p>
Both edges	 <p>The diagram shows two full cycles of the TIN signal. Vertical dashed lines mark both rising and falling edges. The internal edge signal shows a narrow pulse for each edge.</p>
"L" level	 <p>The diagram shows two high pulses on the TIN signal. Vertical dashed lines mark the rising and falling edges. The internal edge signal shows a series of pulses during each high pulse. A horizontal double-headed arrow indicates the "Prescaler output period or TCLK input period".</p>
"H" level	 <p>The diagram shows two low pulses on the TIN signal. Vertical dashed lines mark the rising and falling edges. The internal edge signal shows a series of pulses during each low pulse. A horizontal double-headed arrow indicates the "Prescaler output period or TCLK input period".</p>

TCLK Input Processing Control Register (TCLKCR)

&lt;Address: H'0080 0210&gt;

b0	1	2	3	4	5	6	7	8	9	10	11	12	13	14	b15
0		TCLK3S		0		TCLK2S		0		TCLK1S		0		TCLK0S	
0		0		0		0		0		0		0		0	

&lt;Upon exiting reset: H'0000&gt;

b	Bit Name	Function	R	W
0, 1	No function assigned. Fix to "0."		0	0
2, 3	TCLK3S TCLK3 input processing select bit	00: BCLK/2 or BCLK/4 (Note 1) 01: Rising edge 10: Falling edge 11: Both edges	R	W
4	No function assigned. Fix to "0."		0	0
5–7	TCLK2S TCLK2 input processing select bit	000: Disable input 001: Rising edge 010: Falling edge 011: Both edges 100: "L" level 101: "L" level 110: "H" level 111: "H" level	R	W
8	No function assigned. Fix to "0."		0	0
9–11	TCLK1S TCLK1 input processing select bit	000: Disable input 001: Rising edge 010: Falling edge 011: Both edges 100: "L" level 101: "L" level 110: "H" level 111: "H" level	R	W
12,13	No function assigned. Fix to "0."		0	0
14,15	TCLK0S TCLK0 input processing select bit	00: BCLK/2 or BCLK/4 (Note 1) 01: Rising edge 10: Falling edge 11: Both edges	R	W

Note 1: To select BCLK/2 or BCLK/4, use the PRS012CKS (prescaler 0-2, TML0,1 supplied clock select) bit of the Common Count Clock Select Register (CNTCLKSEL). For details, refer to Section 10.2.2, "Common Count Clock Select Function."

Note: • This register must always be accessed in halfwords.

TIN Input Processing Control Register 0 (TINCR0)

<Address: H'0080 0212>

b0	1	2	3	4	5	6	7	8	9	10	11	12	13	14	b15
TIN4S		TIN3S		TIN2S		TIN1S		TIN0S							
0	0	0	0	0	0	0	0	0	0	0	0	0	0	0	0

<Upon exiting reset: H'0000>

b	Bit Name	Function	R	W
0	No function assigned. Fix to "0."		0	0
1-3	TIN4S TIN4 input processing select bit	000: Disable input 001: Rising edge 010: Falling edge 011: Both edges 100: "L" level 101: "L" level 110: "H" level 111: "H" level	R	W
4	No function assigned. Fix to "0."		0	0
5-7	TIN3S TIN3 input processing select bit	000: Disable input 001: Rising edge 010: Falling edge 011: Both edges 100: "L" level 101: "L" level 110: "H" level 111: "H" level	R	W
8,9	No function assigned. Fix to "0."		0	0
10,11	TIN2S Reserved bit	Fix to "0"	0	0
12,13	TIN1S Reserved bit	Fix to "0"	0	0
14,15	TIN0S TIN0 input processing select bit	00: Disable input 01: Rising edge 10: Falling edge 11: Both edges	R	W

Note: • This register must always be accessed in halfwords.

TIN Input Processing Control Register 1 (TINCR1)

<Address: H'0080 0214>

b0	1	2	3	4	5	6	7	8	9	10	11	12	13	14	b15
TIN8S				TIN7S				TIN6S				TIN5S			
0	0	0	0	0	0	0	0	0	0	0	0	0	0	0	0

<Upon exiting reset: H'0000>

b	Bit Name	Function	R	W
0	No function assigned. Fix to "0."		0	0
1–3	TIN8S TIN8 input processing select bit	000: Disable input 001: Rising edge 010: Falling edge 011: Both edges 100: "L" level 101: "L" level 110: "H" level 111: "H" level	R	W
4	No function assigned. Fix to "0."		0	0
5–7	TIN7S TIN7 input processing select bit	000: Disable input 001: Rising edge 010: Falling edge 011: Both edges 100: "L" level 101: "L" level 110: "H" level 111: "H" level	R	W
8	No function assigned. Fix to "0."		0	0
9–11	TIN6S TIN6 input processing select bit	000: Disable input 001: Rising edge 010: Falling edge 011: Both edges 100: "L" level 101: "L" level 110: "H" level 111: "H" level	R	W
12	No function assigned. Fix to "0."		0	0
13–15	TIN5S TIN5 input processing select bit	000: Disable input 001: Rising edge 010: Falling edge 011: Both edges 100: "L" level 101: "L" level 110: "H" level 111: "H" level	R	W

Note: • This register must always be accessed in halfwords.

TIN Input Processing Control Register 2 (TINCR2)

<Address: H'0080 0216>



<Upon exiting reset: H'0000>

b	Bit Name	Function	R	W
0–4	No function assigned. Fix to "0."		0	0
5–7	TIN11S TIN11 input processing select bit	000: Disable input 001: Rising edge 010: Falling edge 011: Both edges 100: "L" level 101: "L" level 110: "H" level 111: "H" level	R	W
8	No function assigned. Fix to "0."		0	0
9–11	TIN10S TIN10 input processing select bit	000: Disable input 001: Rising edge 010: Falling edge 011: Both edges 100: "L" level 101: "L" level 110: "H" level 111: "H" level	R	W
12	No function assigned. Fix to "0."		0	0
13–15	TIN9S TIN9 input processing select bit	000: Disable input 001: Rising edge 010: Falling edge 011: Both edges 100: "L" level 101: "L" level 110: "H" level 111: "H" level	R	W

Note: • This register must always be accessed in halfwords.



TIN Input Processing Control Register 3 (TINCR3)

&lt;Address: H'0080 0218&gt;

b0	1	2	3	4	5	6	7	8	9	10	11	12	13	14	b15
TIN19S		TIN18S		TIN17S		TIN16S		TIN15S		TIN14S		TIN13S		TIN12S	
0	0	0	0	0	0	0	0	0	0	0	0	0	0	0	0

&lt;Upon exiting reset: H'0000&gt;

b	Bit Name	Function	R	W
0, 1	TIN19S (TIN19 input processing select bit)	00: Disable input	R	W
2, 3	TIN18S (TIN18 input processing select bit)	01: Rising edge		
4, 5	TIN17S (TIN17 input processing select bit)	10: Falling edge		
6, 7	TIN16S (TIN16 input processing select bit)	11: Both edges		
8, 9	TIN15S (Reserved bit)	Fix to "0"	0	0
10, 11	TIN14S (Reserved bit)			
12, 13	TIN13S (Reserved bit)			
14, 15	TIN12S (Reserved bit)			

Note: • This register must always be accessed in halfwords.

TIN Input Processing Control Register 4 (TINCR4)

&lt;Address: H'0080 021A&gt;

b0	1	2	3	4	5	6	7	8	9	10	11	12	13	14	b15
TIN33S		TIN32S		TIN31S		TIN30S		TIN29S		TIN28S		TIN27S		TIN26S	
0	0	0	0	0	0	0	0	0	0	0	0	0	0	0	0

&lt;Upon exiting reset: H'0000&gt;

b	Bit Name	Function	R	W
0, 1	TIN33S (TIN33 input processing select bit)	00: Disable input	R	W
2, 3	TIN32S (TIN32 input processing select bit)	01: Rising edge		
4, 5	TIN31S (TIN31 input processing select bit)	10: Falling edge		
6, 7	TIN30S (TIN30 input processing select bit)	11: Both edges		
8, 9	TIN23S (TIN23 input processing select bit)			
10, 11	TIN22S (TIN22 input processing select bit)			
12, 13	TIN21S (TIN21 input processing select bit)			
14, 15	TIN20S (TIN20 input processing select bit)			

Note: • This register must always be accessed in halfwords.

TIN24,25 Input Processing Control Register (TIN2425CR)

&lt;Address: H'0080 07E1&gt;

b8	9	10	11	12	13	14	b15
0				TIN25S		TIN24S	
0				0		0	

&lt;Upon exiting reset: H'00&gt;

b	Bit Name	Function	R	W
8–11	No function assigned. Fix to "0."		0	0
12, 13	TIN25S (TIN25 input processing select bit)	00: Disable input	R	W
14, 15	TIN24S (TIN24 input processing select bit)	01: Rising edge 10: Falling edge 11: Both edges		

TIN26,27 Input Processing Control Register (TIN2627CR)

&lt;Address: H'0080 0BE1&gt;

b8	9	10	11	12	13	14	b15
0				TIN27S		TIN26S	
0				0		0	

&lt;Upon exiting reset: H'00&gt;

b	Bit Name	Function	R	W
8–11	No function assigned. Fix to "0."		0	0
12, 13	TIN27S (TIN27 input processing select bit)	00: Disable input	R	W
14, 15	TIN26S (TIN26 input processing select bit)	01: Rising edge 10: Falling edge 11: Both edges		

### 10.2.6 Output Flip-flop Control Unit

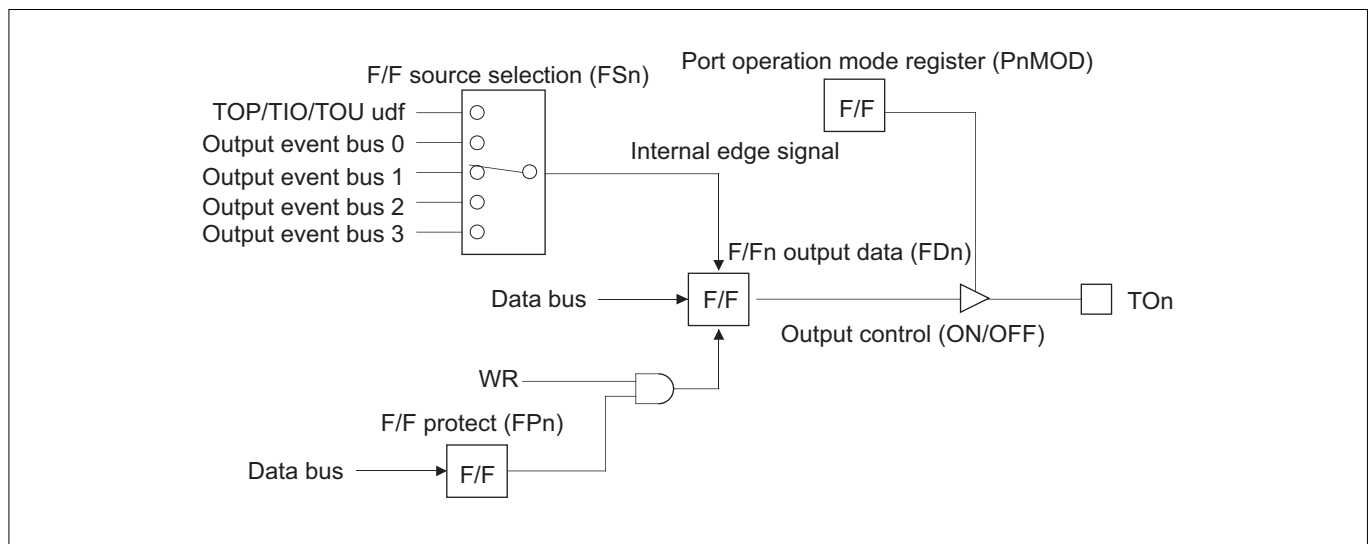
The Output Flip-flop Control Unit controls the flip-flops (F/F) provided for each timer. Following flip-flop control registers are included:

- F/F Source Select Register 0 (FFS0)
- F/F Source Select Register 1 (FFS1)
- F/F Protect Register 0 (FFP0)
- F/F Protect Register 1 (FFP1)
- F/F21–28 Protect Register (FF2128P)
- F/F29–36 Protect Register (FF2936P)
- F/F Data Register 0 (FFD0)
- F/F Data Register 1 (FFD1)
- F/F21–28 Data Register (FF2128D)
- F/F29–36 Data Register (FF2936D)

The timing at which signals are generated to the output flip-flop by each timer are shown in Table 10.2.5. (Note that this timing is different from one at which signals are output from the timer to the output event bus.)

**Table 10.2.5 Timing at Which Signals Are Generated to the Output Flip-Flop by Each Timer**

Timer	Mode	Timing at which signals are generated to the output flip-flop
TOP	Single-shot output mode	When count is enabled or underflows
	Delayed single-shot output mode	When counter underflows
	Continuous output mode	When count is enabled or underflows
TIO	Measure clear input mode	When counter underflows
	Measure free-run input mode	When counter underflows
	Noise processing input mode	When counter underflows
	PWM output mode	When count is enabled or underflows
	Single-shot output mode	When count is enabled or underflows
	Delayed single-shot output mode	When counter underflows
	Continuous output mode	When count is enabled or underflows
TMS	(16-bit measure input)	No signals generated
TML	(32-bit measure input)	No signals generated
TID	Fixed period count mode	No signals generated
	Event count mode	No signals generated
	Multiply-by-4 event count mode	No signals generated
	Up/down event count mode	No signals generated
TOU	PWM output mode	When count is enabled or underflows
	Single-shot PWM output mode	When counter underflows
	Delayed single-shot output mode	When counter underflows
	Single-shot output mode	When count is enabled or underflows
	Continuous output mode	When count is enabled or underflows



**Figure 10.2.3 Configuration of the F/F Output Circuit**

F/F Source Select Register 0 (FFS0)

&lt;Address: H'0080 0220&gt;

b0	1	2	3	4	5	6	7	8	9	10	11	12	13	14	b15
			FS15	FS14	FS13	FS12	FS11	FS10		FS9		FS8		FS7	FS6
0   0   0			0	0	0	0	0	0   0		0   0		0   0		0	0

&lt;Upon exiting reset: H'0000&gt;

b	Bit Name	Function	R	W
0–2	No function assigned. Fix to "0."		0	0
3	FS15 F/F15 source select bit	0: TIO4 output 1: Output event bus 0	R	W
4	FS14 F/F14 source select bit	0: TIO3 output 1: Output event bus 0	R	W
5	FS13 F/F13 source select bit	0: TIO2 output 1: Output event bus 3	R	W
6	FS12 F/F12 source select bit	0: TIO1 output 1: Output event bus 2	R	W
7	FS11 F/F11 source select bit	0: TIO0 output 1: Output event bus 1	R	W
8, 9	FS10 F/F10 source select bit	00: TOP10 output 01: TOP10 output 10: Output event bus 0 11: Output event bus 1	R	W
10, 11	FS9 F/F9 source select bit	00: TOP9 output 01: TOP9 output 10: Output event bus 0 11: Output event bus 1	R	W
12, 13	FS8 F/F8 source select bit	00: TOP8 output 01: Output event bus 0 10: Output event bus 1 11: Output event bus 2	R	W
14	FS7 F/F7 source select bit	0: TOP7 output 1: Output event bus 0	R	W
15	FS6 F/F6 source select bit	0: TOP6 output 1: Output event bus 1	R	W

Note: • This register must always be accessed in halfwords.

F/F Source Select Register 1 (FFS1)

&lt;Address: H'0080 0223&gt;

b8	9	10	11	12	13	14	b15
FS19		FS18		FS17		FS16	
0	0	0	0	0	0	0	0

&lt;Upon exiting reset: H'0000&gt;

b	Bit Name	Function	R	W
8, 9	FS19 F/F19 source select bit	00: TIO8 output 01: TIO8 output 10: Output event bus 0 11: Output event bus 1	R	W
10, 11	FS18 F/F18 source select bit	00: TIO7 output 01: TIO7 output 10: Output event bus 0 11: Output event bus 1	R	W
12, 13	FS17 F/F17 source select bit	00: TIO6 output 01: TIO6 output 10: Output event bus 0 11: Output event bus 1	R	W
14, 15	FS16 F/F16 source select bit	00: TIO5 output 01: Output event bus 0 10: Output event bus 1 11: Output event bus 3	R	W

These registers select the signal source for each output F/F (flip-flop). This signal source can be chosen to be a signal from the internal output bus or an underflow output from each timer.

F/F Protect Register 0 (FFP0)

&lt;Address: H'0080 0224&gt;

b0 1 2 3 4 5 6 7 8 9 10 11 12 13 14 b15

FP15	FP14	FP13	FP12	FP11	FP10	FP9	FP8	FP7	FP6	FP5	FP4	FP3	FP2	FP1	FP0
0	0	0	0	0	0	0	0	0	0	0	0	0	0	0	0

&lt;Upon exiting reset: H'0000&gt;

b	Bit Name	Function	R	W
0	FP15 (F/F15 protect bit)	0: Enable write to F/F output bit	R	W
1	FP14 (F/F14 protect bit)	1: Disable write to F/F output bit		
2	FP13 (F/F13 protect bit)			
3	FP12 (F/F12 protect bit)			
4	FP11 (F/F11 protect bit)			
5	FP10 (F/F10 protect bit)			
6	FP9 (F/F9 protect bit)			
7	FP8 (F/F8 protect bit)			
8	FP7 (F/F7 protect bit)			
9	FP6 (F/F6 protect bit)			
10	FP5 (F/F5 protect bit)			
11	FP4 (F/F4 protect bit)			
12	FP3 (F/F3 protect bit)			
13	FP2 (F/F2 protect bit)			
14	FP1 (F/F1 protect bit)			
15	FP0 (F/F0 protect bit)			

Note: • This register must always be accessed in halfwords.

F/F Protect Register 1 (FFP1)

&lt;Address: H'0080 0229&gt;

b8 9 10 11 12 13 14 b15

0	0	0	FP20	FP19	FP18	FP17	FP16
			0	0	0	0	0

&lt;Upon exiting reset: H'00&gt;

b	Bit Name	Function	R	W
8–10	No function assigned. Fix to "0."		0	0
11	FP20 (F/F20 protect bit)	0: Enable write to F/F output bit	R	W
12	FP19 (F/F19 protect bit)	1: Disable write to F/F output bit		
13	FP18 (F/F18 protect bit)			
14	FP17 (F/F17 protect bit)			
15	FP16 (F/F16 protect bit)			

F/F21–28 Protect Register (FF2128P)

&lt;Address: H'0080 07D5&gt;

b8	9	10	11	12	13	14	b15
FP21	FP22	FP23	FP24	FP25	FP26	FP27	FP28
0	0	0	0	0	0	0	0

&lt;Upon exiting reset: H'00&gt;

b	Bit Name	Function	R	W
8	FP21 (F/F21 protect bit)	0: Enable write to F/F output bit	R	W
9	FP22 (F/F22 protect bit)	1: Disable write to F/F output bit		
10	FP23 (F/F23 protect bit)			
11	FP24 (F/F24 protect bit)			
12	FP25 (F/F25 protect bit)			
13	FP26 (F/F26 protect bit)			
14	FP27 (F/F27 protect bit)			
15	FP28 (F/F28 protect bit)			

F/F29–36 Protect Register (FF2936P)

&lt;Address: H'0080 0BD5&gt;

b8	9	10	11	12	13	14	b15
FP29	FP30	FP31	FP32	FP33	FP34	FP35	FP36
0	0	0	0	0	0	0	0

&lt;Upon exiting reset: H'00&gt;

b	Bit Name	Function	R	W
8	FP29 (F/F29 protect bit)	0: Enable write to F/F output bit	R	W
9	FP30 (F/F30 protect bit)	1: Disable write to F/F output bit		
10	FP31 (F/F31 protect bit)			
11	FP32 (F/F32 protect bit)			
12	FP33 (F/F33 protect bit)			
13	FP34 (F/F34 protect bit)			
14	FP35 (F/F35 protect bit)			
15	FP36 (F/F36 protect bit)			

These registers control write to each output F/F (flip-flop) by enabling or disabling. If write to any output F/F is disabled, writing to the F/F data register has no effect.

F/F Data Register 0 (FFD0)

<Address: H'0080 0226>

b0	1	2	3	4	5	6	7	8	9	10	11	12	13	14	b15
FD15	FD14	FD13	FD12	FD11	FD10	FD9	FD8	FD7	FD6	FD5	FD4	FD3	FD2	FD1	FD0
0	0	0	0	0	0	0	0	0	0	0	0	0	0	0	0

<Upon exiting reset: H'0000>

b	Bit Name	Function	R	W
0	FD15 (F/F15 output data bit)	0: F/F output data = 0	R	W
1	FD14 (F/F14 output data bit)	1: F/F output data = 1		
2	FD13 (F/F13 output data bit)			
3	FD12 (F/F12 output data bit)			
4	FD11 (F/F11 output data bit)			
5	FD10 (F/F10 output data bit)			
6	FD9 (F/F9 output data bit)			
7	FD8 (F/F8 output data bit)			
8	FD7 (F/F7 output data bit)			
9	FD6 (F/F6 output data bit)			
10	FD5 (F/F5 output data bit)			
11	FD4 (F/F4 output data bit)			
12	FD3 (F/F3 output data bit)			
13	FD2 (F/F2 output data bit)			
14	FD1 (F/F1 output data bit)			
15	FD0 (F/F0 output data bit)			

Note: • This register must always be accessed in halfwords.

F/F Data Register 1 (FFD1)

<Address: H'0080 022B>

b8	9	10	11	12	13	14	b15
			FD20	FD19	FD18	FD17	FD16
0	0	0	0	0	0	0	0

<Upon exiting reset: H'00>

b	Bit Name	Function	R	W
8–10	No function assigned. Fix to "0."		0	0
11	FD20 (F/F20 output data bit)	0: F/F output data = 0	R	W
12	FD19 (F/F19 output data bit)	1: F/F output data = 1		
13	FD18 (F/F18 output data bit)			
14	FD17 (F/F17 output data bit)			
15	FD16 (F/F16 output data bit)			



F/F21–28 Data Register (FF2128D)

&lt;Address: H'0080 07D7&gt;

b8	9	10	11	12	13	14	b15
FD21	FD22	FD23	FD24	FD25	FD26	FD27	FD28
0	0	0	0	0	0	0	0

&lt;Upon exiting reset: H'00&gt;

b	Bit Name	Function	R	W
8	FD21 (F/F21 output data bit)	0: F/F output data = 0	R	W
9	FD22 (F/F22 output data bit)	1: F/F output data = 1		
10	FD23 (F/F23 output data bit)			
11	FD24 (F/F24 output data bit)			
12	FD25 (F/F25 output data bit)			
13	FD26 (F/F26 output data bit)			
14	FD27 (F/F27 output data bit)			
15	FD28 (F/F28 output data bit)			

F/F29–36 Data Register (FF2936D)

&lt;Address: H'0080 0BD7&gt;

b8	9	10	11	12	13	14	b15
FD29	FD30	FD31	FD32	FD33	FD34	FD35	FD36
0	0	0	0	0	0	0	0

&lt;Upon exiting reset: H'00&gt;

b	Bit Name	Function	R	W
8	FD29 (F/F29 output data bit)	0: F/F output data = 0	R	W
9	FD30 (F/F30 output data bit)	1: F/F output data = 1		
10	FD31 (F/F31 output data bit)			
11	FD32 (F/F32 output data bit)			
12	FD33 (F/F33 output data bit)			
13	FD34 (F/F34 output data bit)			
14	FD35 (F/F35 output data bit)			
15	FD36 (F/F36 output data bit)			

These registers are used to set data in each output F/F (flip-flop). Although F/F output normally changes with timer output, setting data 0 or 1 in this register allows to produce desired output from any F/F. The F/F data register can only be operated on when the F/F protect register described earlier is enabled for write.

### 10.2.7 Interrupt Control Unit

The Interrupt Control Unit controls the interrupt request signals output to the Interrupt Controller by each timer. Following timer interrupt control registers are provided for each timer:

- TOP Interrupt Control Register 0 (TOPIR0)
- TOP Interrupt Control Register 1 (TOPIR1)
- TOP Interrupt Control Register 2 (TOPIR2)
- TOP Interrupt Control Register 3 (TOPIR3)
- TIO Interrupt Control Register 0 (TIOIR0)
- TIO Interrupt Control Register 1 (TIOIR1)
- TIO Interrupt Control Register 2 (TIOIR2)
- TMS Interrupt Control Register (TMSIR)
- TIN Interrupt Control Register 0 (TINIR0)
- TIN Interrupt Control Register 1 (TINIR1)
- TIN Interrupt Control Register 2 (TINIR2)
- TIN Interrupt Control Register 3 (TINIR3)
- TIN Interrupt Control Register 4 (TINIR4)
- TIN Interrupt Control Register 5 (TINIR5)
- TIN Interrupt Control Register 6 (TINIR6)
- TIN24,25 Interrupt Request Mask Register (TIN2425IMA)
- TIN24,25 Interrupt Request Status Register (TIN2425IST)
- TIN26,27 Interrupt Request Mask Register (TIN2627IMA)
- TIN26,27 Interrupt Request Status Register (TIN2627IST)
- TIN Interrupt Control Register 7 (TINIR7)
- TOU0 Interrupt Request Mask Register (TOU0IMA)
- TOU0 Interrupt Request Status Register (TOU0IST)
- TOU1 Interrupt Request Mask Register (TOU1IMA)
- TOU1 Interrupt Request Status Register (TOU1IST)

For interrupts which have only one interrupt request source in the interrupt vector table, no interrupt control registers are included in the timer, and the interrupt request status flags are automatically managed within the Interrupt Controller. For details, see Chapter 5, "Interrupt Controller."

- TOP10      TOP10 Output Interrupt Request (IRQ5)
- TID0      TID0 Output Interrupt Request (IRQ14)
- TID1      TID1 Output Interrupt Request (IRQ15)

For interrupts which have two or more interrupt sources in the interrupt vector table, interrupt control registers are included, with which to control interrupt requests and determine interrupt input. Therefore, the status flags in the Interrupt Controller only serve as a bit to determine interrupt requests from interrupt-enabled sources and cannot be accessed for write.

### (1) Interrupt request status bit

This status bit is used to determine whether there is an interrupt request. When an interrupt request occurs, this bit is set in hardware (cannot be set in software). The status bit is cleared by writing "0." Writing "1" has no effect; the bit retains the status it had before the write. Because this status bit is unaffected by the interrupt request mask bit, it can be used to inspect the operating status of peripheral functions.

In interrupt handling, make sure that within the interrupt request status grouped as a group interrupt, only the status bit for the interrupt request that has been serviced is cleared. If the status bit for any interrupt request that has not been serviced is cleared, the pending interrupt request is cleared simultaneously with its status bit.

### (2) Interrupt request mask bit

This bit is used to disable unnecessary interrupts within the interrupt request grouped as a group interrupt. Set this bit to "0" to enable interrupt requests or "1" to disable interrupt requests.

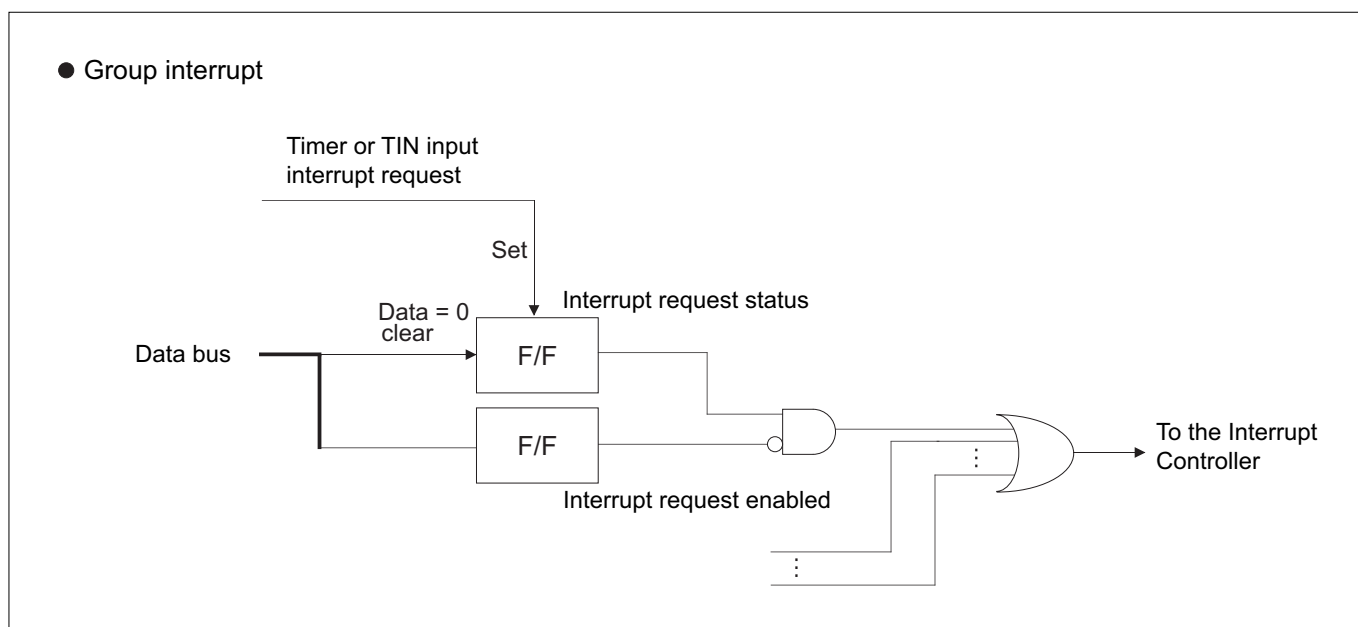
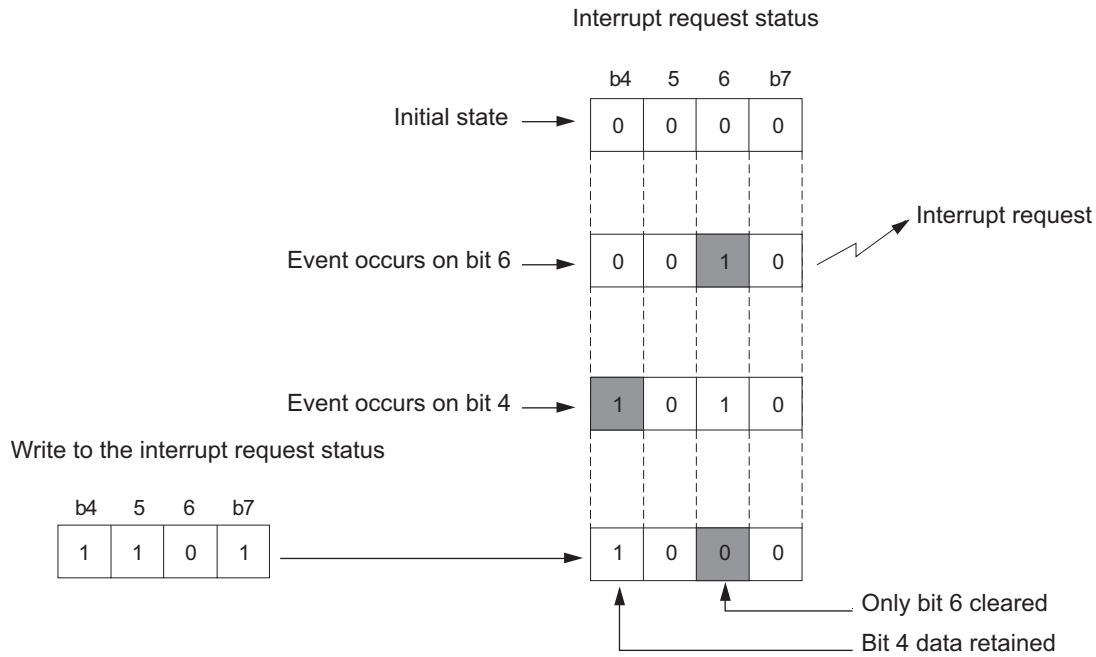


Figure 10.2.4 Interrupt Request Status and Mask Registers

● Example for clearing interrupt request status



● Program example

- To clear the Interrupt Request Status Register 0 (ISTREG) interrupt request status 1, ISTAT1 (0x02 bit)



```
ISTREG = 0xfd; /* Clear ISTAT1 (0x02 bit) only */
```

To clear an interrupt request status, always be sure to write "1" to all other interrupt request status bits. At this time, avoid using a logic operation like the one shown below. Because it requires three step-ISTREG read, logic operation and write, if another interrupt request occurs between the read and write, status may be inadvertently cleared.



```
ISTREG &= 0xfd; /* Clear ISTAT1 (0x02 bit) only */
```

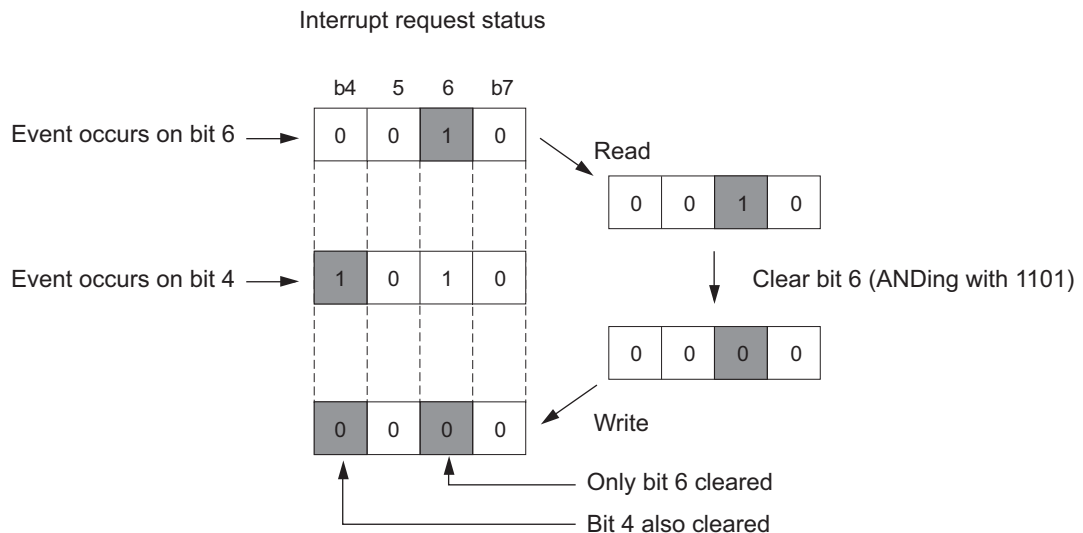


Figure 10.2.5 Example for Clearing Interrupt Request Status

The table below shows the relationship between the interrupt request signals generated by multijunction timers and the interrupt sources input to the Interrupt Controller (ICU).

**Table 10.2.6 Interrupt Request Signals Generated by MJT**

Signal Name	Generated by	Interrupt Request Source (Note 1)	No. of ICU Input Sources
IRQ0	TIO0, TIO1, TIO2, TIO3	MJT output interrupt 0	4
IRQ1	TOP6, TOP7	MJT output interrupt 1	2
IRQ2	TOP0, TOP1, TOP2, TOP3, TOP4, TOP5	MJT output interrupt 2	6
IRQ3	TIO8, TIO9	MJT output interrupt 3	2
IRQ4	TIO4, TIO5, TIO6, TIO7	MJT output interrupt 4	4
IRQ6	TOP8, TOP9	MJT output interrupt 5	2
IRQ7	TMS0, TMS1	MJT output interrupt 6	2
IRQ8	TIN7, TIN8, TIN9, TIN10, TIN11	MJT input interrupt 0	5
IRQ9	TIN0	MJT input interrupt 1	1
IRQ10	TIN16, TIN17, TIN18, TIN19	MJT input interrupt 2	4
IRQ11	TIN20, TIN21, TIN22, TIN23, TIN24, TIN25 TIN26, TIN27	MJT input interrupt 3	8
IRQ12	TIN3, TIN4, TIN5, TIN6	MJT input interrupt 4	4
IRQ13	TOU0_0, TOU0_1, TOU0_2, TOU0_3 TOU0_4, TOU0_5, TOU0_6, TOU0_7	TOU0 output interrupt	8
IRQ16	TOU1_0, TOU1_1, TOU1_2, TOU1_3 TOU1_4, TOU1_5, TOU1_6, TOU1_7	TOU1 output interrupt	8
IRQ18	TIN30, TIN31, TIN32, TIN33	TML1 input interrupt	4

Note 1: See Chapter 5, "Interrupt Controller (ICU)."

Note: • TOP10, TID0 and TID1 have only one interrupt source in each interrupt group, so that their status and mask registers are nonexistent in the MJT interrupt control registers. (They are controlled directly by the Interrupt Controller.)

TOP Interrupt Control Register 0 (TOPIR0)

&lt;Address: H'0080 0230&gt;

b0	1	2	3	4	5	6	b7
0	0	TOPIS5 0	TOPIS4 0	TOPIS3 0	TOPIS2 0	TOPIS1 0	TOPIS0 0

&lt;Upon exiting reset: H'00&gt;

b	Bit Name	Function	R	W
0, 1	No function assigned. Fix to "0."		0	0
2	TOPIS5 (TOP5 interrupt request status bit)	0: Interrupt not requested	R	(Note 1)
3	TOPIS4 (TOP4 interrupt request status bit)	1: Interrupt requested		
4	TOPIS3 (TOP3 interrupt request status bit)			
5	TOPIS2 (TOP2 interrupt request status bit)			
6	TOPIS1 (TOP1 interrupt request status bit)			
7	TOPIS0 (TOP0 interrupt request status bit)			

Note 1: Only writing "0" is effective. Writing "1" has no effect; the bit retains the value it had before the write.

TOP Interrupt Control Register 1 (TOPIR1)

&lt;Address: H'0080 0231&gt;

b8	9	10	11	12	13	14	b15
0	0	TOPIM5 0	TOPIM4 0	TOPIM3 0	TOPIM2 0	TOPIM1 0	TOPIM0 0

&lt;Upon exiting reset: H'00&gt;

b	Bit Name	Function	R	W
8, 9	No function assigned. Fix to "0."		0	0
10	TOPIM5 (TOP5 interrupt request mask bit)	0: Enable interrupt request	R	W
11	TOPIM4 (TOP4 interrupt request mask bit)	1: Mask (disable) interrupt request		
12	TOPIM3 (TOP3 interrupt request mask bit)			
13	TOPIM2 (TOP2 interrupt request mask bit)			
14	TOPIM1 (TOP1 interrupt request mask bit)			
15	TOPIM0 (TOP0 interrupt request mask bit)			

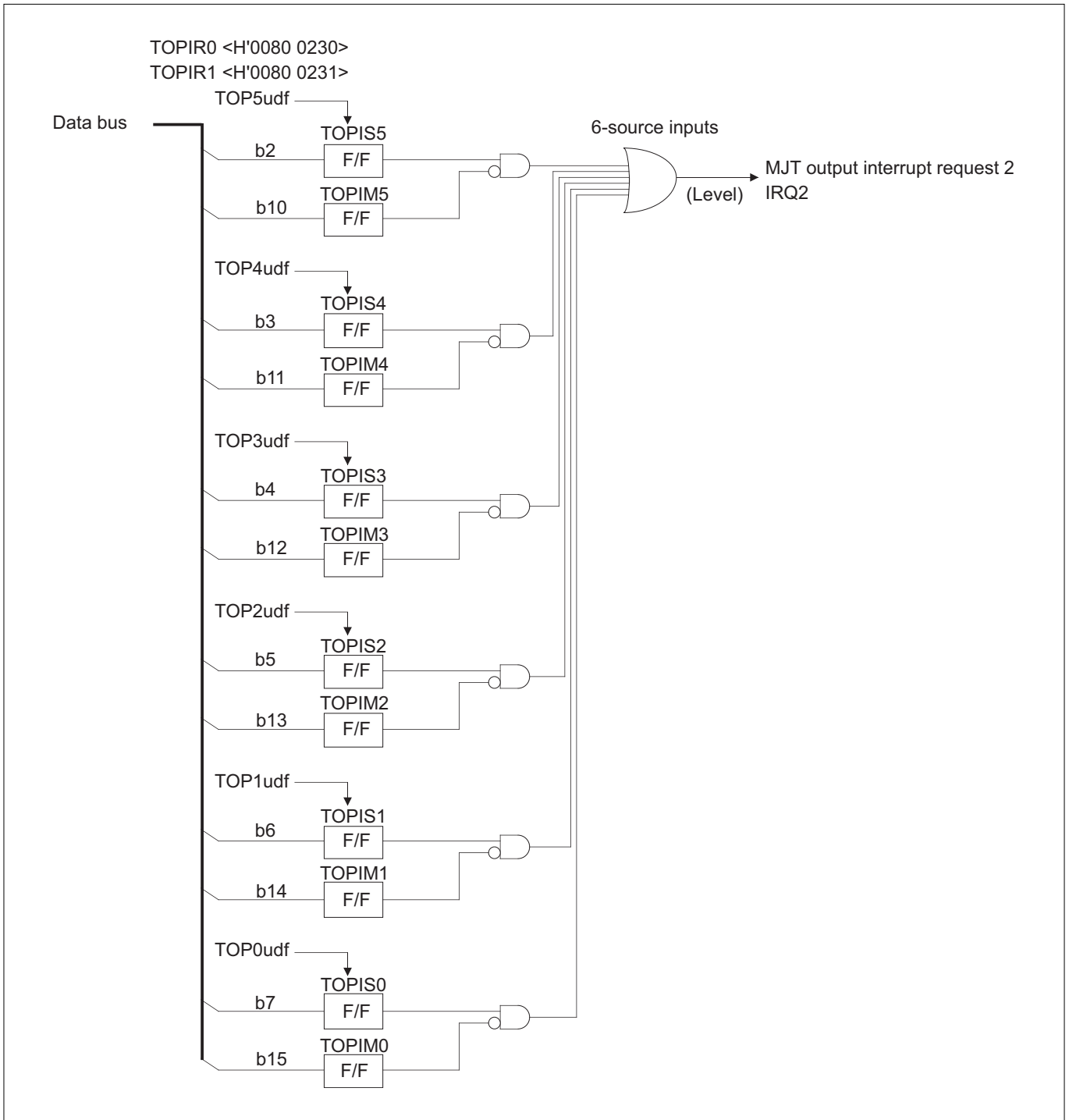


Figure 10.2.6 Block Diagram of MJT Output Interrupt Request 2

TOP Interrupt Control Register 2 (TOPIR2)

<Address: H'0080 0232>

b0	1	2	3	4	5	6	b7
0	0	TOPIS7 0	TOPIS6 0	0	0	TOPIM7 0	TOPIM6 0

<Upon exiting reset: H'00>

b	Bit Name	Function	R	W
0, 1	No function assigned. Fix to "0."		0	0
2	TOPIS7 (TOP7 interrupt request status bit)	0: Interrupt not requested	R(Note 1)	
3	TOPIS6 (TOP6 interrupt request status bit)	1: Interrupt requested		
4, 5	No function assigned. Fix to "0."		0	0
6	TOPIM7 (TOP7 interrupt request mask bit)	0: Enable interrupt request	R	W
7	TOPIM6 (TOP6 interrupt request mask bit)	1: Mask (disable) interrupt request		

Note 1: Only writing "0" is effective. Writing "1" has no effect; the bit retains the value it had before the write.

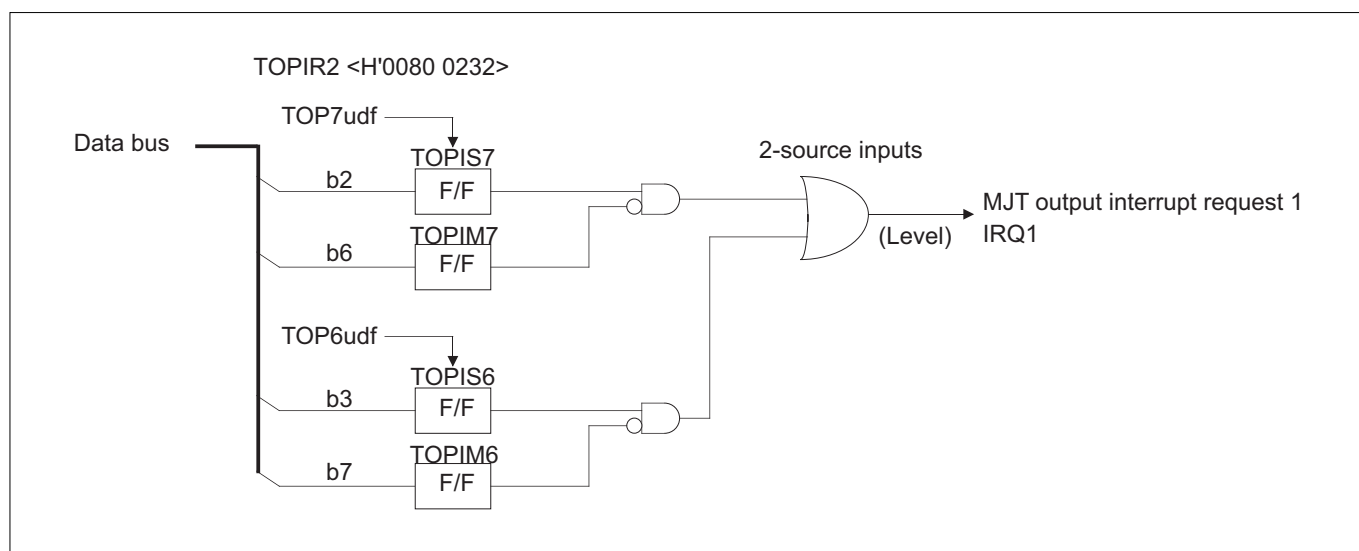


Figure 10.2.7 Block Diagram of MJT Output Interrupt Request 1



TOP Interrupt Control Register 3 (TOPIR3)

<Address: H'0080 0233>

b8	9	10	11	12	13	14	b15
0	0	TOPIS9 0	TOPIS8 0	0	0	TOPIM9 0	TOPIM8 0

<Upon exiting reset: H'00>

b	Bit Name	Function	R	W
8, 9	No function assigned. Fix to "0."		0	0
10	TOPIS9 (TOP9 interrupt request status bit)	0: Interrupt not requested	R(Note 1)	
11	TOPIS8 (TOP8 interrupt request status bit)	1: Interrupt requested		
12, 13	No function assigned. Fix to "0."		0	0
14	TOPIM9 (TOP9 interrupt request mask bit)	0: Enable interrupt request	R	W
15	TOPIM8 (TOP8 interrupt request mask bit)	1: Mask (disable) interrupt request		

Note 1: Only writing "0" is effective. Writing "1" has no effect; the bit retains the value it had before the write.

Note: • TOP10 has only one interrupt source in the interrupt group, so that its status and mask registers are nonexistent in the MJT interrupt control registers. (They are controlled directly by the Interrupt Controller.)

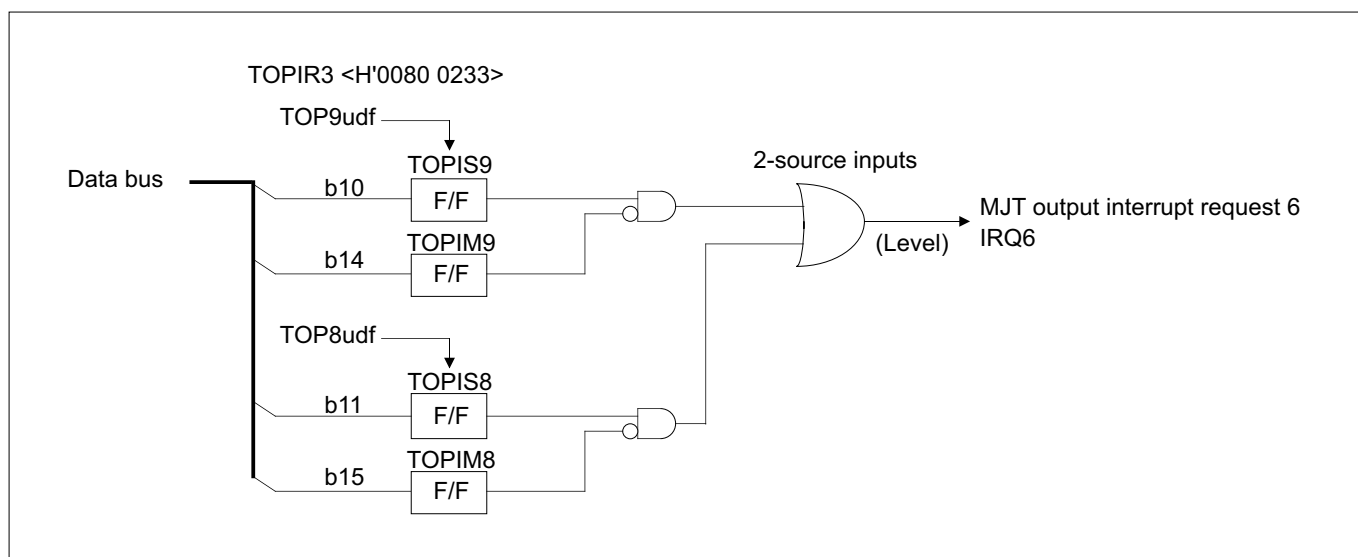


Figure 10.2.8 Block Diagram of MJT Output Interrupt Request 6

TIO Interrupt Control Register 0 (TIOIR0)

<Address: H'0080 0234>

b0	1	2	3	4	5	6	b7
TIOIS3	TIOIS2	TIOIS1	TIOIS0	TIOIM3	TIOIM2	TIOIM1	TIOIM0
0	0	0	0	0	0	0	0

<Upon exiting reset: H'00>

b	Bit Name	Function	R	W
0	TIOIS3 (TIO3 interrupt request status bit)	0: Interrupt not requested	R	(Note 1)
1	TIOIS2 (TIO2 interrupt request status bit)	1: Interrupt requested		
2	TIOIS1 (TIO1 interrupt request status bit)			
3	TIOIS0 (TIO0 interrupt request status bit)			
4	TIOIM3 (TIO3 interrupt request mask bit)	0: Enable interrupt request	R	W
5	TIOIM2 (TIO2 interrupt request mask bit)	1: Mask (disable) interrupt request		
6	TIOIM1 (TIO1 interrupt request mask bit)			
7	TIOIM0 (TIO0 interrupt request mask bit)			

Note 1: Only writing "0" is effective. Writing "1" has no effect; the bit retains the value it had before the write.

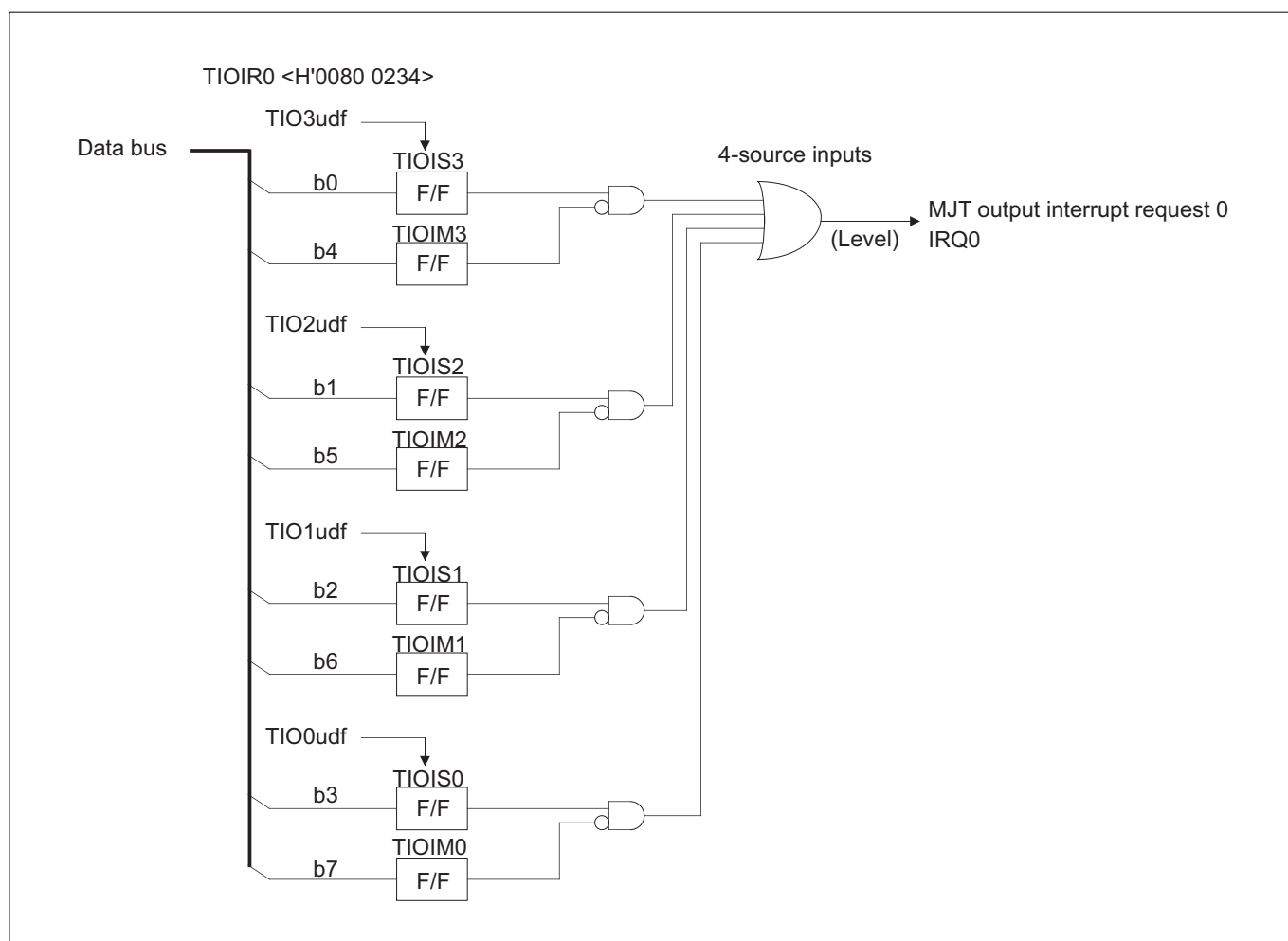


Figure 10.2.9 Block Diagram of MJT Output Interrupt Request 0

TIO Interrupt Control Register 1 (TIOIR1)

<Address: H'0080 0235>

b8	9	10	11	12	13	14	b15
TIOIS7	TIOIS6	TIOIS5	TIOIS4	TIOIM7	TIOIM6	TIOIM5	TIOIM4
0	0	0	0	0	0	0	0

<Upon exiting reset: H'00>

b	Bit Name	Function	R	W
8	TIOIS7 (TIO7 interrupt request status bit)	0: Interrupt not requested	R	(Note 1)
9	TIOIS6 (TIO6 interrupt request status bit)	1: Interrupt requested		
10	TIOIS5 (TIO5 interrupt request status bit)			
11	TIOIS4 (TIO4 interrupt request status bit)			
12	TIOIM7 (TIO7 interrupt request mask bit)	0: Enable interrupt request	R	W
13	TIOIM6 (TIO6 interrupt request mask bit)	1: Mask (disable) interrupt request		
14	TIOIM5 (TIO5 interrupt request mask bit)			
15	TIOIM4 (TIO4 interrupt request mask bit)			

Note 1: Only writing "0" is effective. Writing "1" has no effect; the bit retains the value it had before the write.

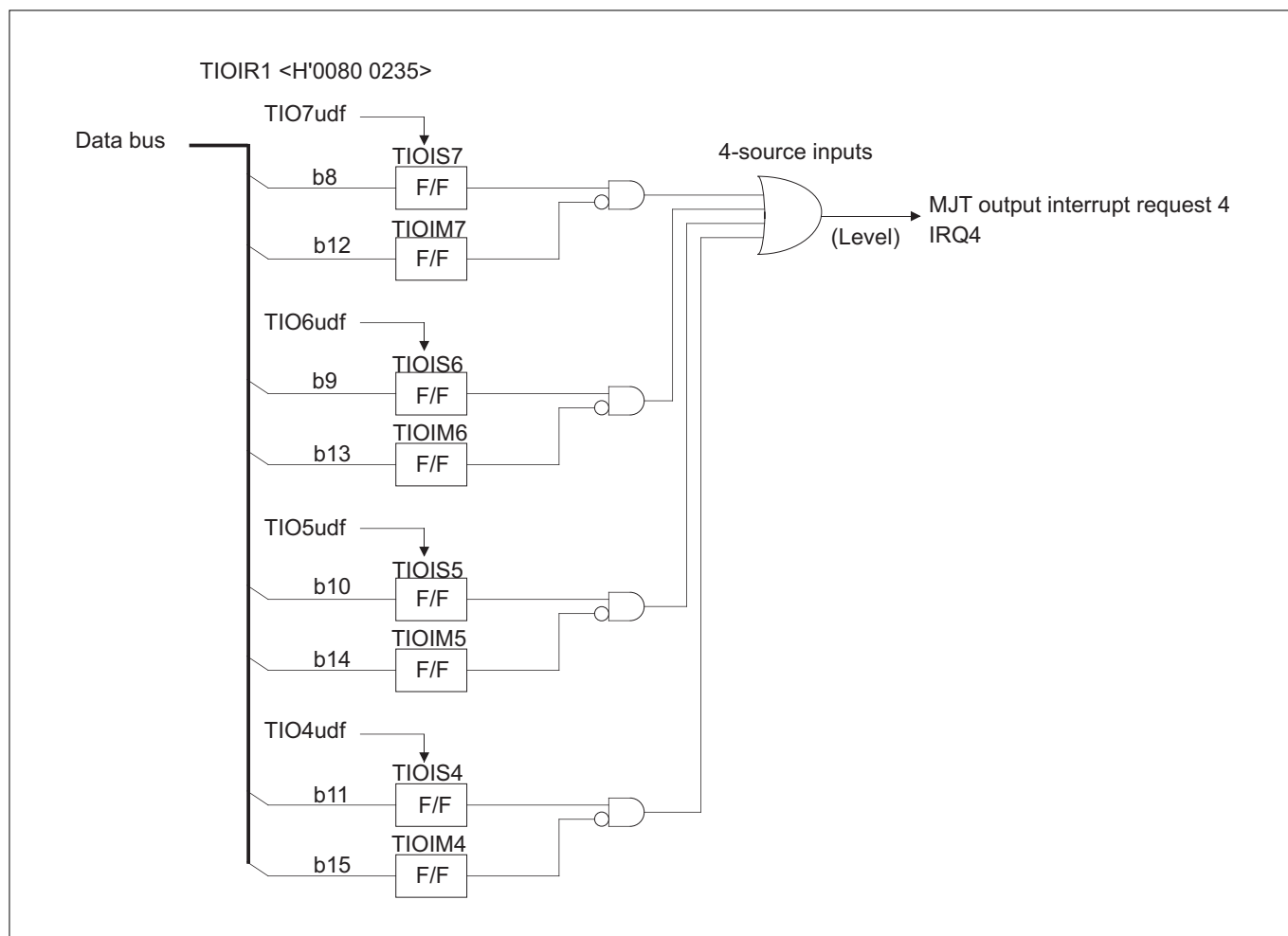


Figure 10.2.10 Block Diagram of MJT Output Interrupt Request 4

TIO Interrupt Control Register 2 (TIOIR2)

<Address: H'0080 0236>

b0	1	2	3	4	5	6	b7
0	0	TIOIS9 0	TIOIS8 0	0	0	TIOIM9 0	TIOIM8 0

<Upon exiting reset: H'00>

b	Bit Name	Function	R	W
0, 1	No function assigned. Fix to "0."		0	0
2	TIOIS9 (TIO9 interrupt request status bit)	0: Interrupt not requested	R(Note 1)	
3	TIOIS8 (TIO8 interrupt request status bit)	1: Interrupt requested		
4, 5	No function assigned. Fix to "0."		0	0
6	TIOIM9 (TIO9 interrupt request mask bit)	0: Enable interrupt request	R	W
7	TIOIM8 (TIO8 interrupt request mask bit)	1: Mask (disable) interrupt request		

Note 1: Only writing "0" is effective. Writing "1" has no effect; the bit retains the value it had before the write.

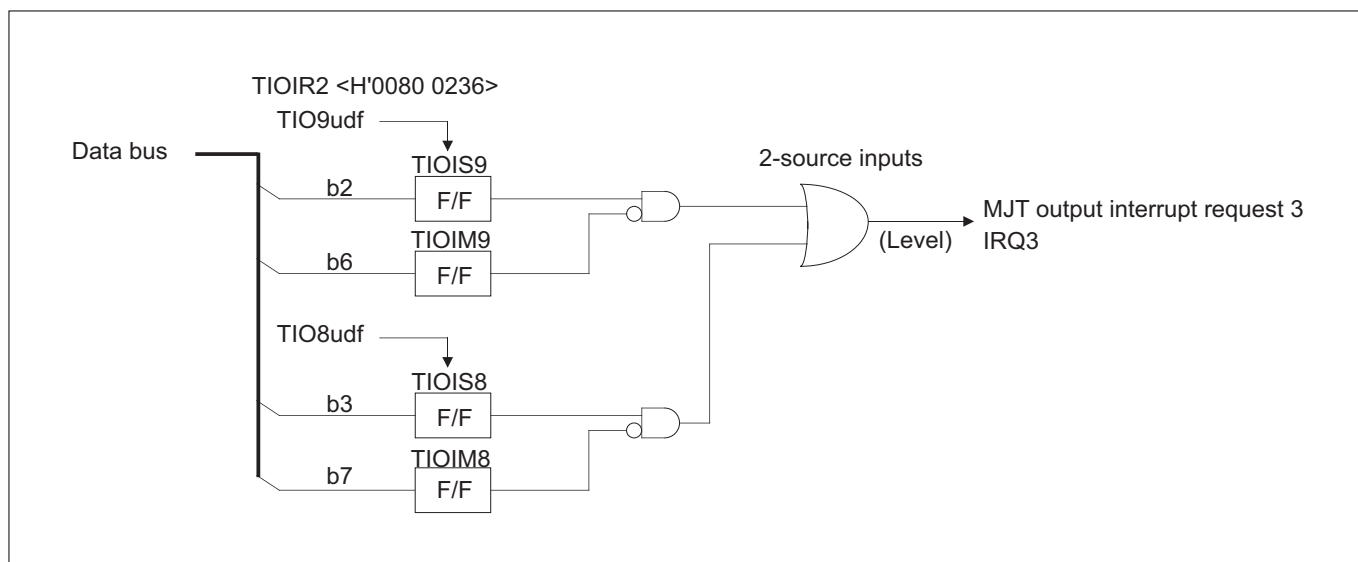


Figure 10.2.11 Block Diagram of MJT Output Interrupt Request 3

TMS Interrupt Control Register (TMSIR)

<Address: H'0080 0237>

b8	9	10	11	12	13	14	b15
0	0	TMSIS1 0	TMSIS0 0	0	0	TMSIM1 0	TMSIM0 0

<Upon exiting reset: H'00>

b	Bit Name	Function	R	W
8, 9	No function assigned. Fix to "0."		0	0
10	TMSIS1 (TMS1 interrupt request status bit)	0: Interrupt not requested	R(Note 1)	
11	TMSIS0 (TMS0 interrupt request status bit)	1: Interrupt requested		
12, 13	No function assigned. Fix to "0."		0	0
14	TMSIM1 (TMS1 interrupt request mask bit)	0: Enable interrupt request	R	W
15	TMSIM0 (TMS0 interrupt request mask bit)	1: Mask (disable) interrupt request		

Note 1: Only writing "0" is effective. Writing "1" has no effect; the bit retains the value it had before the write.

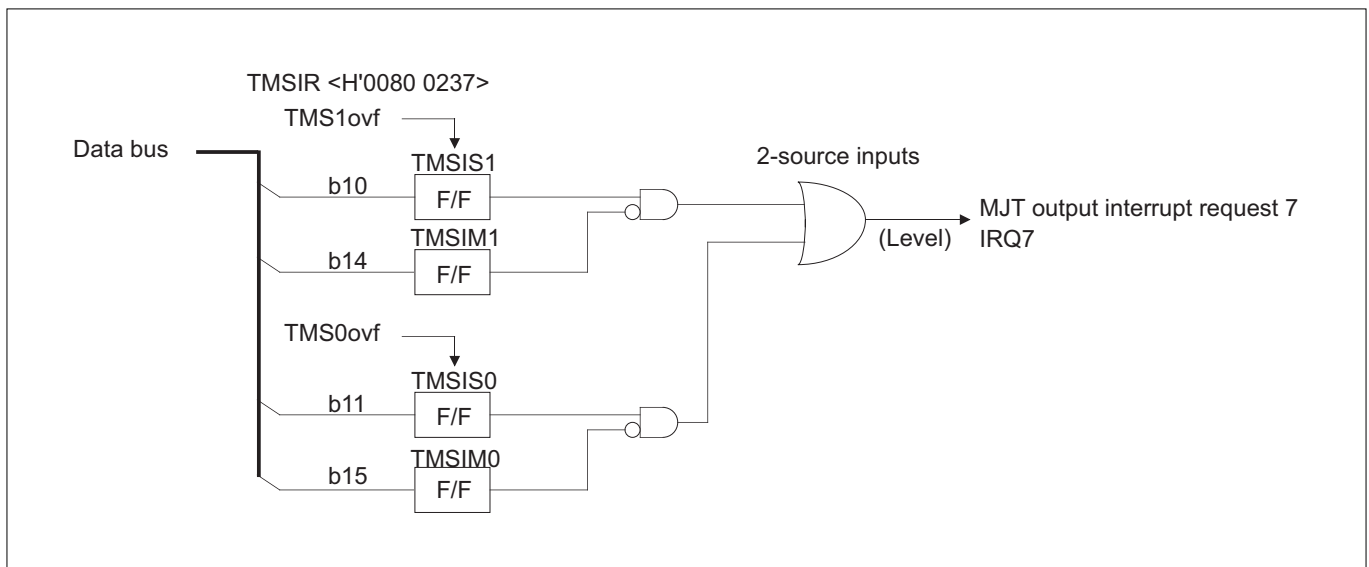


Figure 10.2.12 Block Diagram of MJT Output Interrupt Request 7

TIN Interrupt Control Register 0 (TINIRO)

<Address: H'0080 0238>

b0	1	2	3	4	5	6	b7
0	TINIS2 0	TINIS1 0	TINIS0 0	0	TINIM2 0	TINIM1 0	TINIM0 0

<Upon exiting reset: H'00>

b	Bit Name	Function	R	W
0	No function assigned. Fix to "0."		0	0
1	TINIS2 (Reserved bit)	Fix to "0"	0	0
2	TINIS1 (Reserved bit)			
3	TINIS0 (TIN0 interrupt request status bit)	0: Interrupt not requested 1: Interrupt requested	R (Note 1)	
4	No function assigned. Fix to "0."		0	0
5	TINIM2 (Reserved bit)	Fix to "0"	0	0
6	TINIM1 (Reserved bit)			
7	TINIM0 (TIN0 interrupt request mask bit)	0: Enable interrupt request 1: Mask (disable) interrupt request	R	W

Note 1: Only writing "0" is effective. Writing "1" has no effect; the bit retains the value it had before the write.

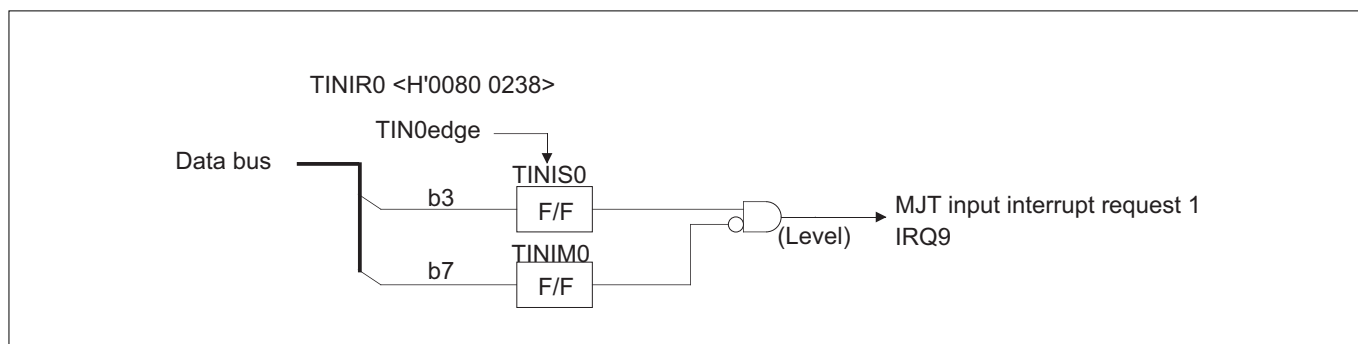


Figure 10.2.13 Block Diagram of MJT Input Interrupt Request 1

TIN Interrupt Control Register 1 (TINIR1)

<Address: H'0080 0239>

b8	9	10	11	12	13	14	b15
TINIS6	TINIS5	TINIS4	TINIS3	TINIM6	TINIM5	TINIM4	TINIM3
0	0	0	0	0	0	0	0

<Upon exiting reset: H'00>

b	Bit Name	Function	R	W
8	TINIS6 (TIN6 interrupt request status bit)	0: Interrupt not requested	R	(Note 1)
9	TINIS5 (TIN5 interrupt request status bit)	1: Interrupt requested		
10	TINIS4 (TIN4 interrupt request status bit)			
11	TINIS3 (TIN3 interrupt request status bit)			
12	TINIM6 (TIN6 interrupt request mask bit)	0: Enable interrupt request	R	W
13	TINIM5 (TIN5 interrupt request mask bit)	1: Mask (disable) interrupt request		
14	TINIM4 (TIN4 interrupt request mask bit)			
15	TINIM3 (TIN3 interrupt request mask bit)			

Note 1: Only writing "0" is effective. Writing "1" has no effect; the bit retains the value it had before the write.

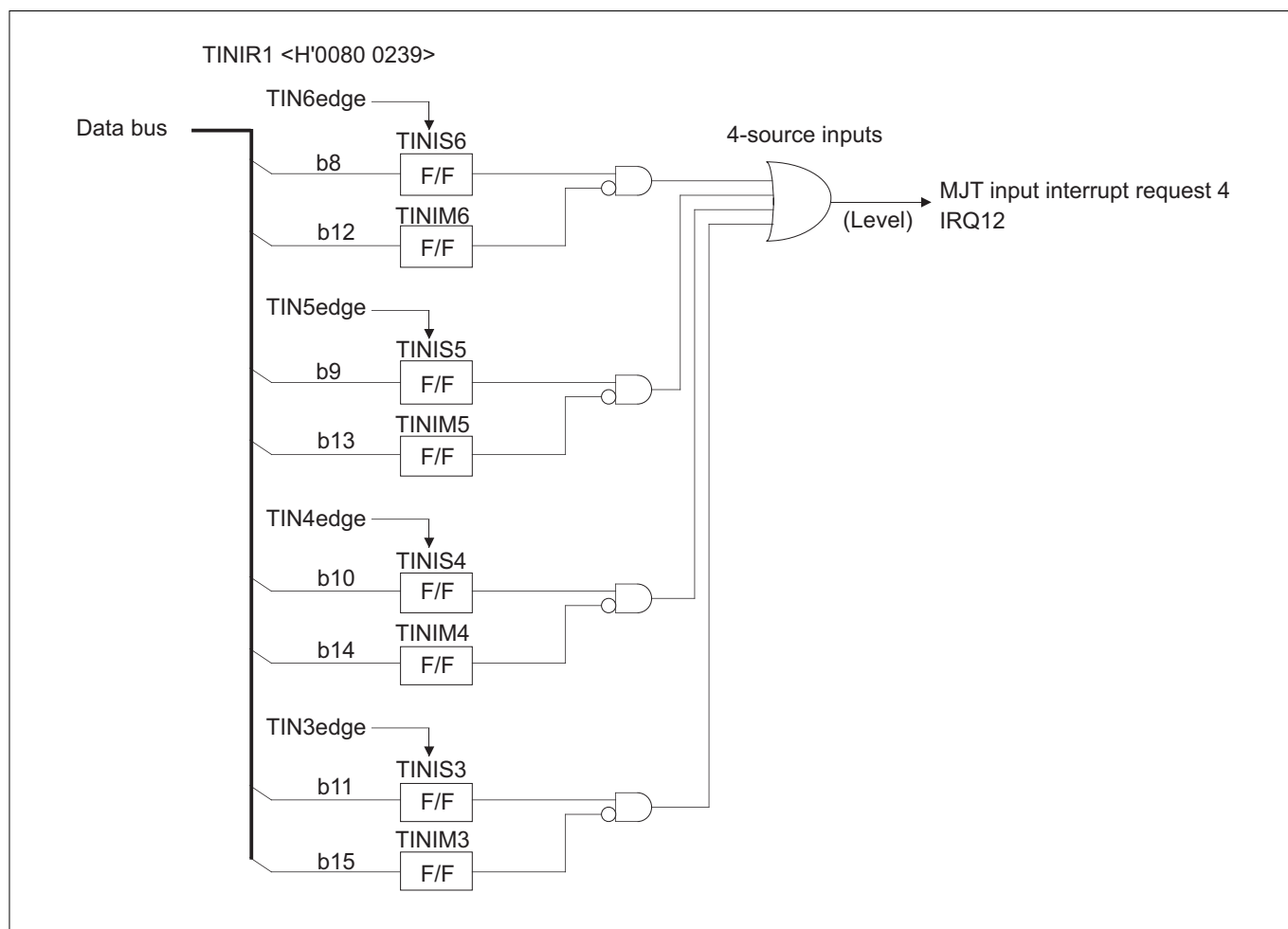


Figure 10.2.14 Block Diagram of MJT Input Interrupt Request 4

TIN Interrupt Control Register 2 (TINIR2)

<Address: H'0080 023A>

b0	1	2	3	4	5	6	b7
0	0	0	TINIS11 0	TINIS10 0	TINIS9 0	TINIS8 0	TINIS7 0

<Upon exiting reset: H'00>

b	Bit Name	Function	R	W
0–2	No function assigned. Fix to "0."		0	0
3	TINIS11 (TIN11 interrupt request status bit)	0: Interrupt not requested	R	(Note 1)
4	TINIS10 (TIN10 interrupt request status bit)	1: Interrupt requested		
5	TINIS9 (TIN9 interrupt request status bit)			
6	TINIS8 (TIN8 interrupt request status bit)			
7	TINIS7 (TIN7 interrupt request status bit)			

Note 1: Only writing "0" is effective. Writing "1" has no effect; the bit retains the value it had before the write.

TIN Interrupt Control Register 3 (TINIR3)

<Address: H'0080 023B>

b8	9	10	11	12	13	14	b15
0	0	0	TINIM11 0	TINIM10 0	TINIM9 0	TINIM8 0	TINIM7 0

<Upon exiting reset: H'00>

b	Bit Name	Function	R	W
8–10	No function assigned. Fix to "0."		0	0
11	TINIM11 (TIN11 interrupt request mask bit)	0: Enable interrupt request	R	W
12	TINIM10 (TIN10 interrupt request mask bit)	1: Mask (disable) interrupt request		
13	TINIM9 (TIN9 interrupt request mask bit)			
14	TINIM8 (TIN8 interrupt request mask bit)			
15	TINIM7 (TIN7 interrupt request mask bit)			



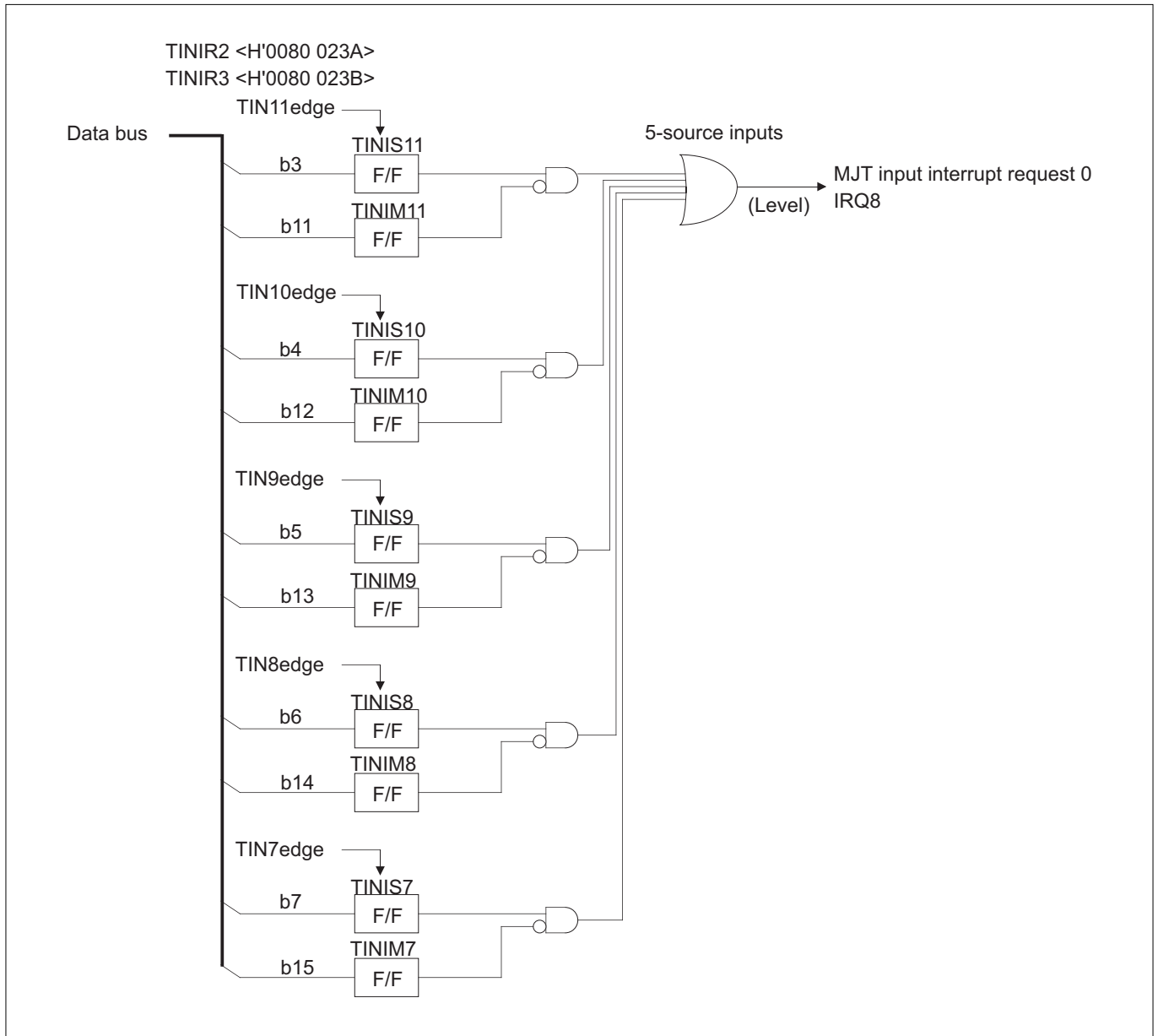


Figure 10.2.15 Block Diagram of MJT Input Interrupt Request 0

TIN Interrupt Control Register 4 (TINIR4)

&lt;Address: H'0080 023C&gt;

b0	1	2	3	4	5	6	b7
TINIS19	TINIS18	TINIS17	TINIS16	TINIS15	TINIS14	TINIS13	TINIS12
0	0	0	0	0	0	0	0

&lt;Upon exiting reset: H'00&gt;

b	Bit Name	Function	R	W
0	TINIS19 (TIN19 interrupt request status bit)	0: Interrupt not requested	R	W
1	TINIS18 (TIN18 interrupt request status bit)	1: Interrupt requested		
2	TINIS17 (TIN17 interrupt request status bit)			
3	TINIS16 (TIN16 interrupt request status bit)			
4	TINIS15 (Reserved bit)	Fix to "0"	0	0
5	TINIS14 (Reserved bit)			
6	TINIS13 (Reserved bit)			
7	TINIS12 (Reserved bit)			

Note 1: Only writing "0" is effective. Writing "1" has no effect; the bit retains the value it had before the write.

TIN Interrupt Control Register 5 (TINIR5)

&lt;Address: H'0080 023D&gt;

b8	9	10	11	12	13	14	b15
TINIM19	TINIM18	TINIM17	TINIM16	TINIM15	TINIM14	TINIM13	TINIM12
0	0	0	0	0	0	0	0

&lt;Upon exiting reset: H'00&gt;

b	Bit Name	Function	R	W
8	TINIM19 (TIN19 interrupt request mask bit)	0: Enable interrupt request	R	W
9	TINIM18 (TIN18 interrupt request mask bit)	1: Mask (disable) interrupt request		
10	TINIM17 (TIN17 interrupt request mask bit)			
11	TINIM16 (TIN16 interrupt request mask bit)			
12	TINIM15 (Reserved bit)	Fix to "0"	0	0
13	TINIM14 (Reserved bit)			
14	TINIM13 (Reserved bit)			
15	TINIM12 (Reserved bit)			

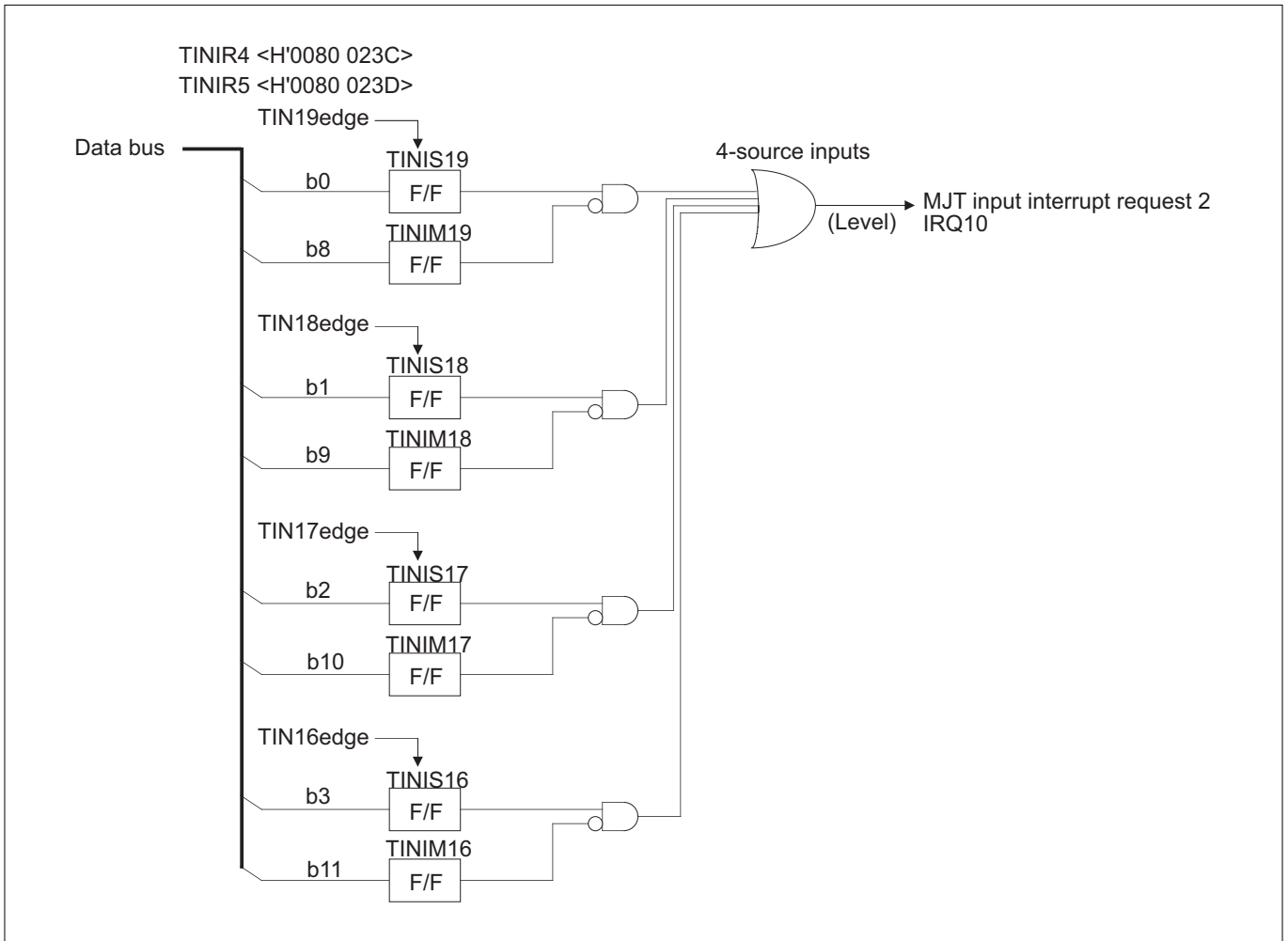


Figure 10.2.16 Block Diagram of MJT Input Interrupt Request 2

TIN Interrupt Control Register 6 (TINIR6)

&lt;Address: H'0080 023E&gt;

b0	1	2	3	4	5	6	b7
TINIS23	TINIS22	TINIS21	TINIS20	TINIM23	TINIM22	TINIM21	TINIM20
0	0	0	0	0	0	0	0

&lt;Upon exiting reset: H'00&gt;

b	Bit Name	Function	R	W
0	TINIS23 (TIN23 interrupt request status bit)	0: Interrupt not requested	R	(Note 1)
1	TINIS22 (TIN22 interrupt request status bit)	1: Interrupt requested		
2	TINIS21 (TIN21 interrupt request status bit)			
3	TINIS20 (TIN20 interrupt request status bit)			
4	TINIM23 (TIN23 interrupt request mask bit)	0: Enable interrupt request	R	W
5	TINIM22 (TIN22 interrupt request mask bit)	1: Mask (disable) interrupt request		
6	TINIM21 (TIN21 interrupt request mask bit)			
7	TINIM20 (TIN20 interrupt request mask bit)			

Note 1: Only writing "0" is effective. Writing "1" has no effect; the bit retains the value it had before the write.

TIN24,25 Interrupt Request Mask Register (TIN2425IMA)

&lt;Address: H'0080 07E2&gt;

b0	1	2	3	4	5	6	b7
0	0	0	0	0	0	TINIM24	TINIM25
0	0	0	0	0	0	0	0

&lt;Upon exiting reset: H'00&gt;

b	Bit Name	Function	R	W
0–5	No function assigned. Fix to "0."		0	0
6	TINIM24 (TIN24 interrupt request mask bit)	0: Enable interrupt request	R	W
7	TINIM25 (TIN25 interrupt request mask bit)	1: Mask (disable) interrupt request		

TIN24,25 Interrupt Request Status Register (TIN2425IST)

&lt;Address: H'0080 07E3&gt;

b8	9	10	11	12	13	14	b15
0	0	0	0	0	0	TINIS24	TINIS25
0	0	0	0	0	0	0	0

&lt;Upon exiting reset: H'00&gt;

b	Bit Name	Function	R	W
8–13	No function assigned. Fix to "0."		0	0
14	TINIS24 (TIN24 interrupt request status bit)	0: Interrupt not requested	R	(Note 1)
15	TINIS25 (TIN25 interrupt request status bit)	1: Interrupt requested		

Note 1: Only writing "0" is effective. Writing "1" has no effect; the bit retains the value it had before the write.

TIN26,27 Interrupt Request Mask Register (TIN2627IMA)

&lt;Address: H'0080 0BE2&gt;

b0	1	2	3	4	5	6	b7
0	0	0	0	0	0	TINIM26 0	TINIM27 0

&lt;Upon exiting reset: H'00&gt;

b	Bit Name	Function	R	W
0–5	No function assigned. Fix to "0."		0	0
6	TINIM26 (TIN26 interrupt request mask bit)	0: Enable interrupt request	R	W
7	TINIM27 (TIN27 interrupt request mask bit)	1: Mask (disable) interrupt request		

TIN26,27 Interrupt Request Status Register (TIN2627IST)

&lt;Address: H'0080 0BE3&gt;

b8	9	10	11	12	13	14	b15
0	0	0	0	0	0	TINIS26 0	TINIS27 0

&lt;Upon exiting reset: H'00&gt;

b	Bit Name	Function	R	W
8–13	No function assigned. Fix to "0."		0	0
14	TINIS26 (TIN26 interrupt request status bit)	0: Interrupt not requested	R(Note 1)	
15	TINIS27 (TIN27 interrupt request status bit)	1: Interrupt requested		

Note 1: Only writing "0" is effective. Writing "1" has no effect; the bit retains the value it had before the write.

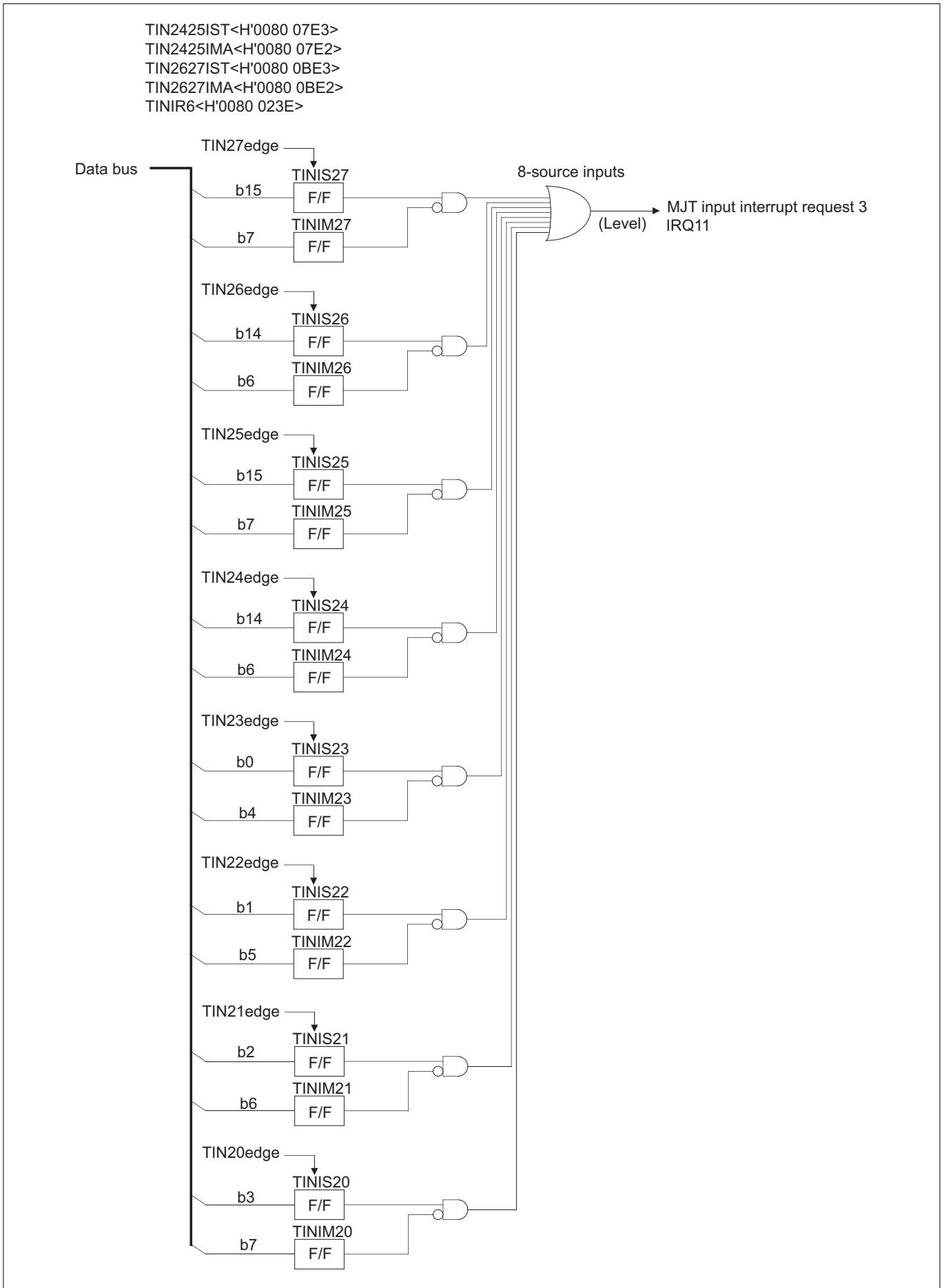


Figure 10.2.17 Block Diagram of MJT Input Interrupt Request 3

TIN Interrupt Control Register 7 (TINIR7)

<Address: H'0080 023F>

b8	9	10	11	12	13	14	b15
TINIS33	TINIS32	TINIS31	TINIS30	TINIM33	TINIM32	TINIM31	TINIM30
0	0	0	0	0	0	0	0

<Upon exiting reset: H'00>

b	Bit Name	Function	R	W
8	TINIS33 (TIN33 interrupt request status bit)	0: Interrupt not requested	R	(Note 1)
9	TINIS32 (TIN32 interrupt request status bit)	1: Interrupt requested		
10	TINIS31 (TIN31 interrupt request status bit)			
11	TINIS30 (TIN30 interrupt request status bit)			
12	TINIM33 (TIN33 interrupt request mask bit)	0: Enable interrupt request	R	W
13	TINIM32 (TIN32 interrupt request mask bit)	1: Mask (disable) interrupt request		
14	TINIM31 (TIN31 interrupt request mask bit)			
15	TINIM30 (TIN30 interrupt request mask bit)			

Note 1: Only writing "0" is effective. Writing "1" has no effect; the bit retains the value it had before the write.

Note: • TIN24–TIN29 do not have interrupt functions, so that their status and mask registers are nonexistent.

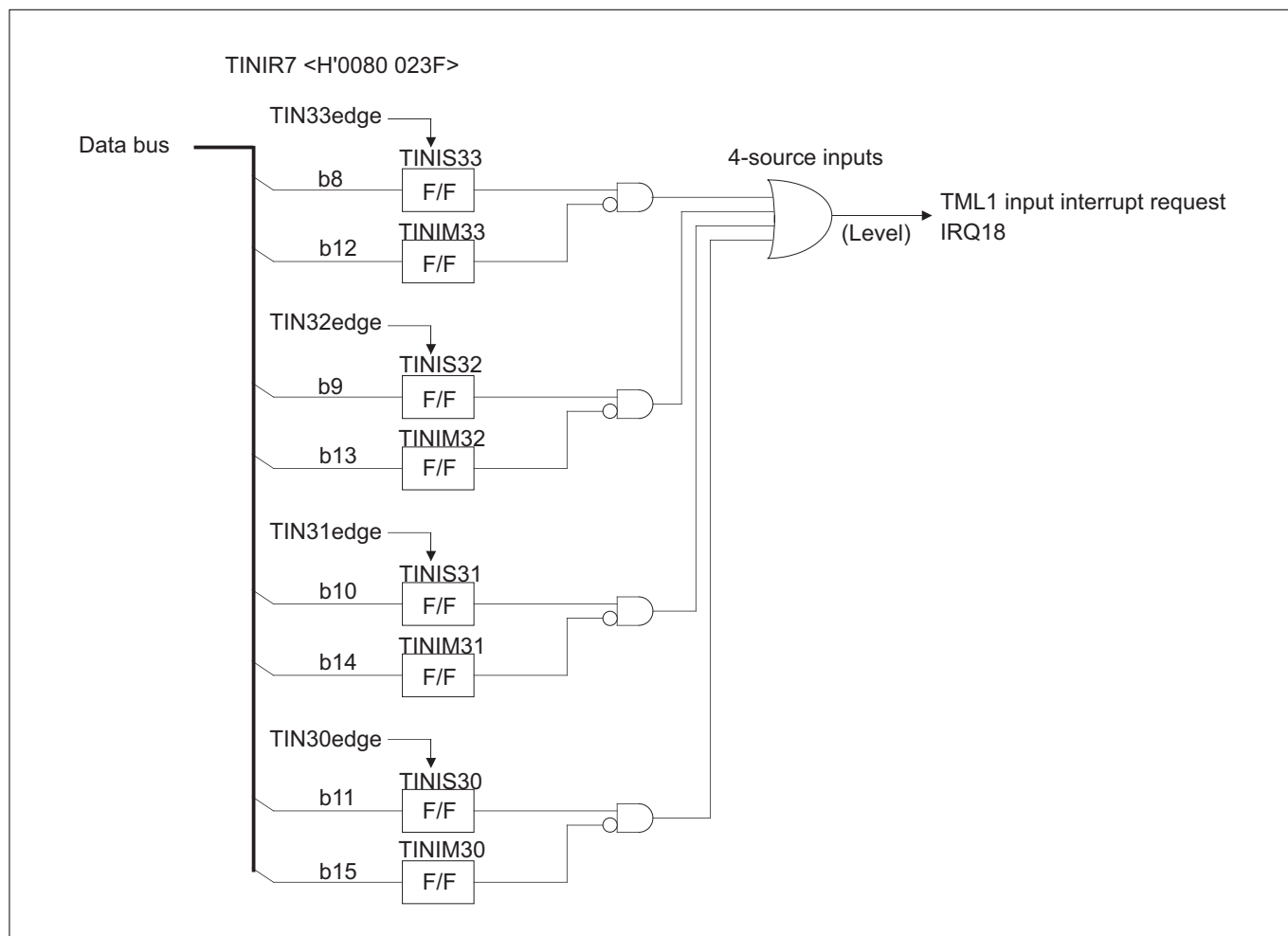


Figure 10.2.18 Block Diagram of TML1 Input Interrupt Request

## TOU0 Interrupt Request Mask Register (TOU0IMA)

&lt;Address: H'0080 07D2&gt;

b0	1	2	3	4	5	6	b7
TOU0IM7	TOU0IM6	TOU0IM5	TOU0IM4	TOU0IM3	TOU0IM2	TOU0IM1	TOU0IM0
0	0	0	0	0	0	0	0

&lt;Upon exiting reset: H'00&gt;

b	Bit Name	Function	R	W
0	TOU0IM7 (TOU0_7 interrupt request mask bit)	0: Enable interrupt request	R	W
1	TOU0IM6 (TOU0_6 interrupt request mask bit)	1: Mask (disable) interrupt request		
2	TOU0IM5 (TOU0_5 interrupt request mask bit)			
3	TOU0IM4 (TOU0_4 interrupt request mask bit)			
4	TOU0IM3 (TOU0_3 interrupt request mask bit)			
5	TOU0IM2 (TOU0_2 interrupt request mask bit)			
6	TOU0IM1 (TOU0_1 interrupt request mask bit)			
7	TOU0IM0 (TOU0_0 interrupt request mask bit)			

## TOU0 Interrupt Request Status Register (TOU0IST)

&lt;Address: H'0080 07D3&gt;

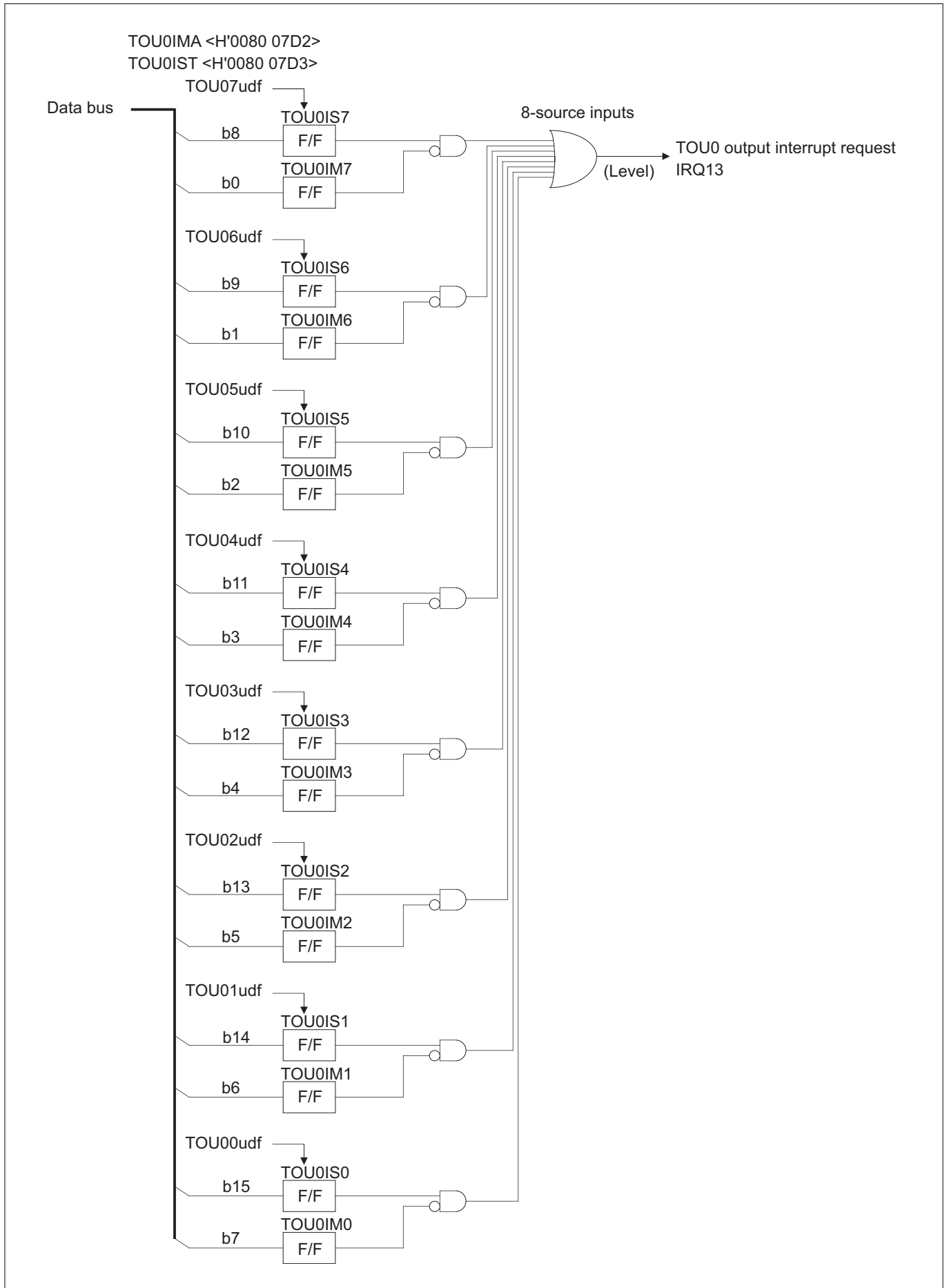
b8	9	10	11	12	13	14	b15
TOU0IS7	TOU0IS6	TOU0IS5	TOU0IS4	TOU0IS3	TOU0IS2	TOU0IS1	TOU0IS0
0	0	0	0	0	0	0	0

&lt;Upon exiting reset: H'00&gt;

b	Bit Name	Function	R	W
8	TOU0IS7 (TOU0_7 interrupt request status bit)	0: Interrupt not requested	R(Note 1)	
9	TOU0IS6 (TOU0_6 interrupt request status bit)	1: Interrupt requested		
10	TOU0IS5 (TOU0_5 interrupt request status bit)			
11	TOU0IS4 (TOU0_4 interrupt request status bit)			
12	TOU0IS3 (TOU0_3 interrupt request status bit)			
13	TOU0IS2 (TOU0_2 interrupt request status bit)			
14	TOU0IS1 (TOU0_1 interrupt request status bit)			
15	TOU0IS0 (TOU0_0 interrupt request status bit)			

Note 1: Only writing "0" is effective. Writing "1" has no effect; the bit retains the value it had before the write.





**Figure 10.2.19** Block Diagram of TOU0 Output Interrupt Request

## TOU1 Interrupt Request Mask Register (TOU1IMA)

&lt;Address: H'0080 0BD2&gt;

b0	1	2	3	4	5	6	b7
TOU1IM7	TOU1IM6	TOU1IM5	TOU1IM4	TOU1IM3	TOU1IM2	TOU1IM1	TOU1IM0
0	0	0	0	0	0	0	0

&lt;Upon exiting reset: H'00&gt;

b	Bit Name	Function	R	W
0	TOU1IM7 (TOU1_7 interrupt request mask bit)	0: Enable interrupt request	R	W
1	TOU1IM6 (TOU1_6 interrupt request mask bit)	1: Mask (disable) interrupt request		
2	TOU1IM5 (TOU1_5 interrupt request mask bit)			
3	TOU1IM4 (TOU1_4 interrupt request mask bit)			
4	TOU1IM3 (TOU1_3 interrupt request mask bit)			
5	TOU1IM2 (TOU1_2 interrupt request mask bit)			
6	TOU1IM1 (TOU1_1 interrupt request mask bit)			
7	TOU1IM0 (TOU1_0 interrupt request mask bit)			

## TOU1 Interrupt Request Status Register (TOU1IST)

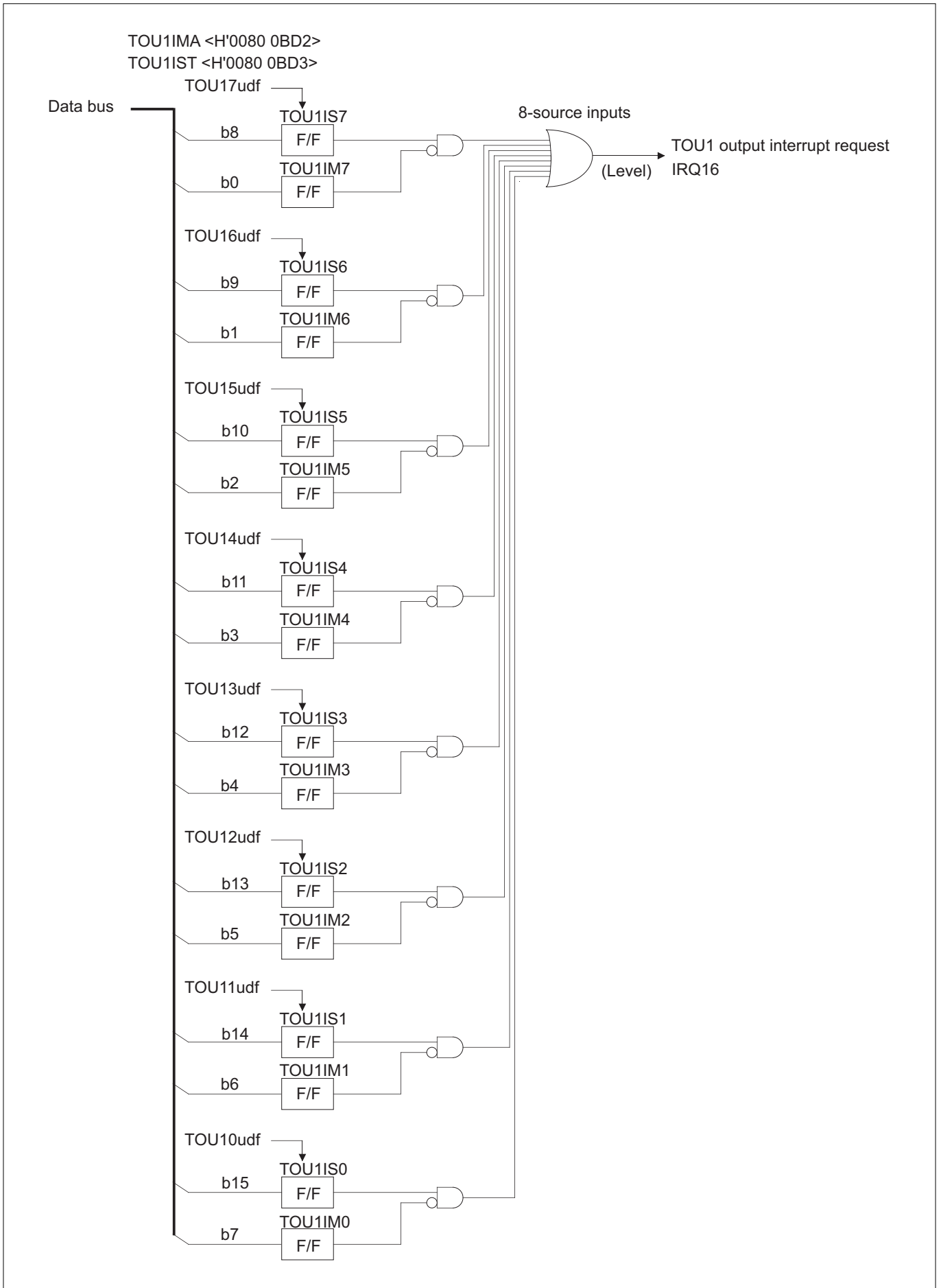
&lt;Address: H'0080 0BD3&gt;

b8	9	10	11	12	13	14	b15
TOU1IS7	TOU1IS6	TOU1IS5	TOU1IS4	TOU1IS3	TOU1IS2	TOU1IS1	TOU1IS0
0	0	0	0	0	0	0	0

&lt;Upon exiting reset: H'00&gt;

b	Bit Name	Function	R	W
8	TOU1IS7 (TOU1_7 interrupt request status bit)	0: Interrupt not requested	R (Note 1)	
9	TOU1IS6 (TOU1_6 interrupt request status bit)	1: Interrupt requested		
10	TOU1IS5 (TOU1_5 interrupt request status bit)			
11	TOU1IS4 (TOU1_4 interrupt request status bit)			
12	TOU1IS3 (TOU1_3 interrupt request status bit)			
13	TOU1IS2 (TOU1_2 interrupt request status bit)			
14	TOU1IS1 (TOU1_1 interrupt request status bit)			
15	TOU1IS0 (TOU1_0 interrupt request status bit)			

Note 1: Only writing "0" is effective. Writing "1" has no effect; the bit retains the value it had before the write.



**Figure 10.2.20 Block Diagram of TOU1 Output Interrupt Request**

## 10.3 TOP (Output-Related 16-Bit Timer)

### 10.3.1 Outline of TOP

TOP (Timer OutPut) is an output-related 16-bit timer, whose operation mode can be selected from the following by mode switching in software:

- Single-shot output mode
- Delayed single-shot output mode
- Continuous output mode

The table below and the diagram in the next page show specifications and a block diagram of TOP, respectively.

**Table 10.3.1 Specifications of TOP (Output-Related 16-Bit Timer)**

Item	Specification
Number of channels	11 channels
Counter	16-bit down-counter
Reload register	16-bit reload register
Correction register	16-bit correction register
Timer startup	Started by writing to the enable bit in software or enabled by external input (rising or falling edge or both)
Operation mode	<With correction function> <ul style="list-style-type: none"> <li>• Single-shot output mode</li> <li>• Delayed single-shot output mode</li> </ul> <Without correction function> <ul style="list-style-type: none"> <li>• Continuous output mode</li> </ul>
Interrupt request generation	Can be generated by a counter underflow

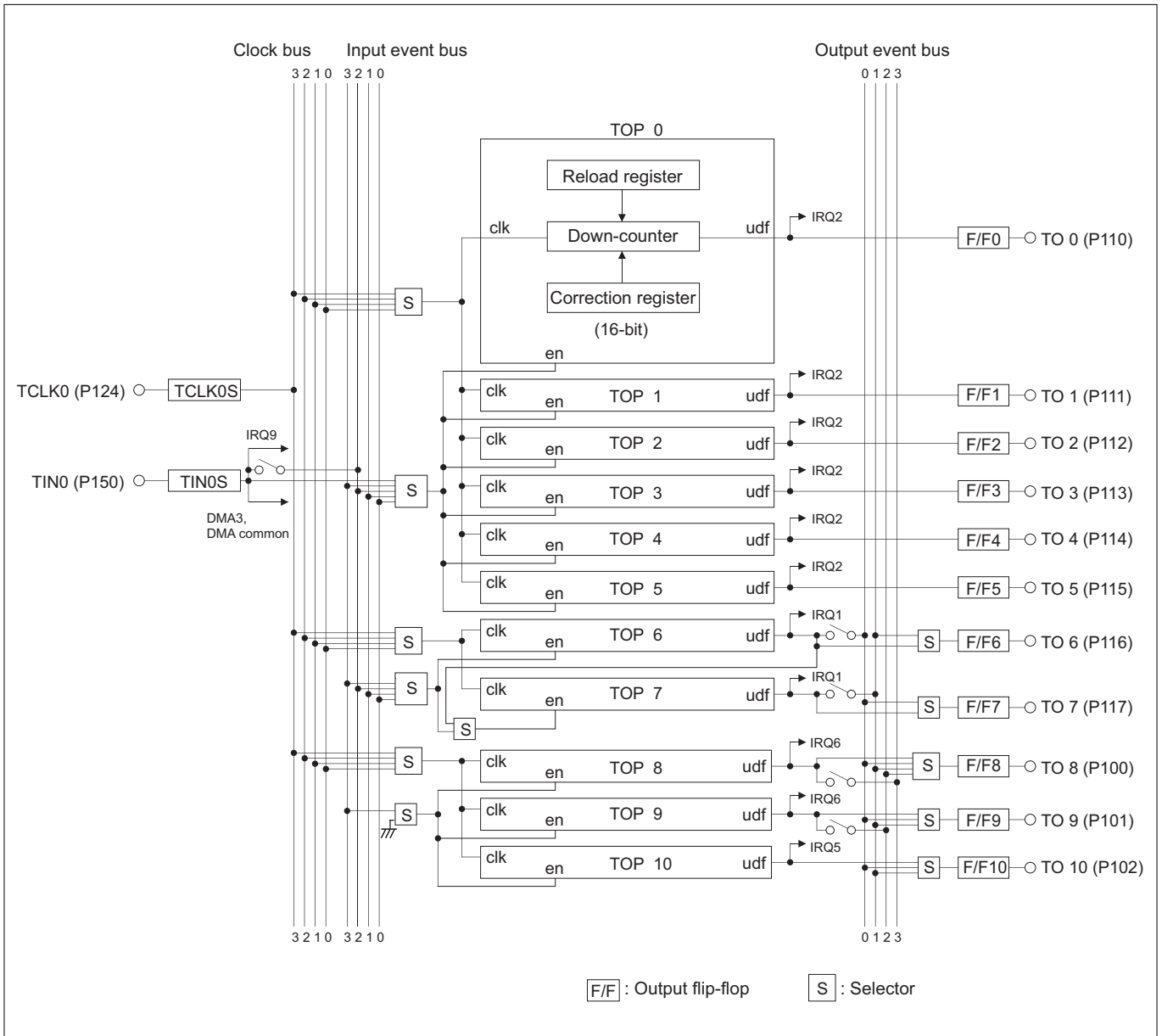


Figure 10.3.1 Block Diagram of TOP (Output-Related 16-Bit Timer)

### 10.3.2 Outline of Each Mode of TOP

Each mode of TOP is outlined below. For each TOP channel, only one of the following modes can be selected.

#### (1) Single-shot output mode

In single-shot output mode, the timer generates a pulse in width of "reload register set value + 1" only once and then stops.

When the timer is enabled (by writing to the enable bit in software or by external input) after setting the reload register, the counter is loaded with the content of "the reload register -1" and starts counting synchronously with the count clock at the next circle. The counter counts down and stops.

The F/F output waveform in single-shot output mode is inverted at enable and upon underflow (F/F output level is changed "L" to "H", or "H" to "L"), generating a single-shot pulse waveform in width of "reload register set value + 1" only once.

And also an interrupt request can be generated when the counter underflows. The counter value is "setting value of reload register +1."

#### (2) Delayed single-shot output mode

In delayed single-shot output mode, the timer generates a pulse in width of "reload register set value + 1" after a finite time equal to "counter set value + 1" only once and then stops.

When the timer is enabled (by writing to the enable bit in software or by external input) after setting the counter and reload register, it starts counting down from the counter's set value synchronously with the count clock.

The next cycle after first counter underflow, it is loaded with "the reload register value -1" and continues counting down. The counter stops when it underflows next time.

The F/F output waveform in delayed single-shot output mode is inverted (F/F output level is changed "L" to "H", or "H" to "L"), when the counter underflows first time and next, generating a single-shot pulse waveform in width of "reload register set value + 1" after a finite time equal to "first set value of counter + 1" only once. And also an interrupt request can be generated when the counter underflows first time and next. The effective counter value is "counter set value +1" or "reload register set value +1."

#### (3) Continuous output mode

In continuous output mode, the timer counts down starting from the set value of the counter and at the cycle after the counter underflows, it is loaded with the value that "the reload register -1". Thereafter, this operation is repeated each time the counter underflows, thus generating consecutive pulses whose waveform is inverted in width of "reload register set value + 1."

When the timer is enabled (by writing to the enable bit in software or by external input) after setting the counter and reload register, it starts counting down from the counter's set value synchronously with the count clock and when the minimum count is reached, generates an underflow.

At the cycle after this underflow, the counter to be loaded with the content of "the reload register -1" and start counting over again. Thereafter, this operation is repeated each time an underflow occurs. To stop the counter, disable count by writing to the enable bit in software.

The F/F output waveform in continuous output mode is inverted (F/F output level is changed "L" to "H", or "H" to "L"), at startup and upon underflow, generating a waveform of consecutive pulses until the timer stops counting. An interrupt request can be generated each time the counter underflows. The effective counter value is "counter set value +1" and "reload register set value +1."

## &lt;Count clock-dependent delay&gt;

- Because the timer operates synchronously with the count clock, up to one count clock-dependent delay is generated by the time when the timer actually starts operating after writing to the enable bit. In operation mode where the F/F output is inverted when the timer is enabled, there is also a count clock-dependent delay before the F/F output is inverted.

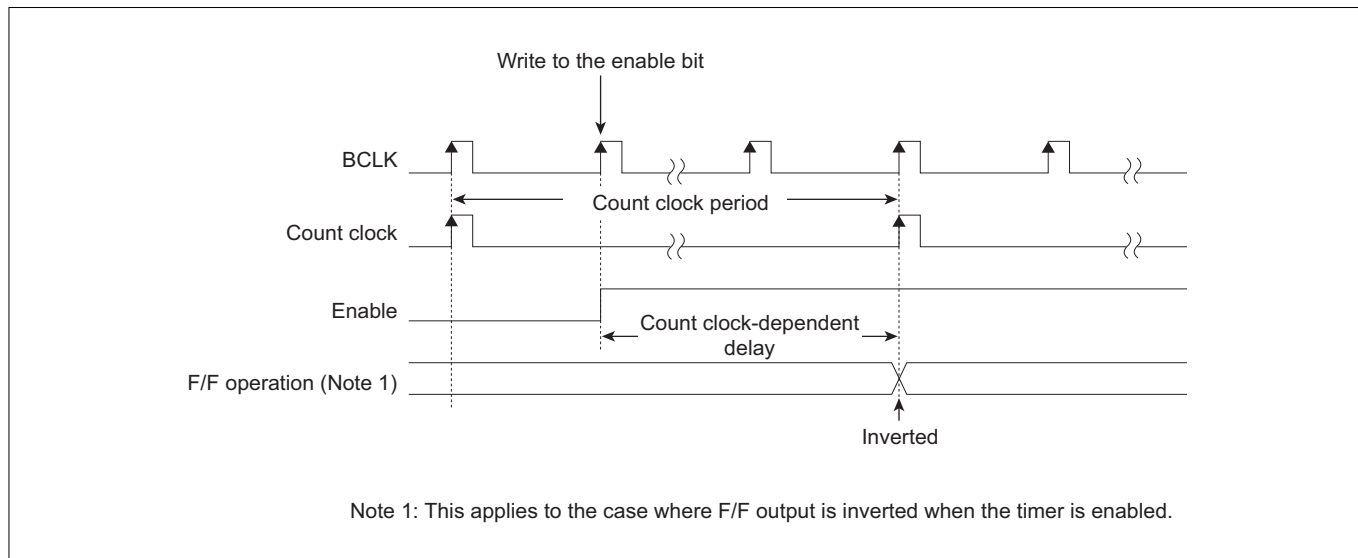


Figure 10.3.2 Count Clock Dependent Delay

## 10.3.3 TOP Related Register Map

Shown below is a TOP related register map.

TOP Related Register Map (1/2)

Address	+0 address	+1 address	See pages
	b0	b7 b8	b15
H'0080 0240		TOP0 Counter (TOP0CT)	10-71
H'0080 0242		TOP0 Reload Register (TOP0RL)	10-72
H'0080 0244		(Use inhibited area)	
H'0080 0246		TOP0 Correction Register (TOP0CC)	10-73
		(Use inhibited area)	
H'0080 0250		TOP1 Counter (TOP1CT)	10-71
H'0080 0252		TOP1 Reload Register (TOP1RL)	10-72
H'0080 0254		(Use inhibited area)	
H'0080 0256		TOP1 Correction Register (TOP1CC)	10-73
		(Use inhibited area)	
H'0080 0260		TOP2 Counter (TOP2CT)	10-71
H'0080 0262		TOP2 Reload Register (TOP2RL)	10-72
H'0080 0264		(Use inhibited area)	
H'0080 0266		TOP2 Correction Register (TOP2CC)	10-73
		(Use inhibited area)	
H'0080 0270		TOP3 Counter (TOP3CT)	10-71
H'0080 0272		TOP3 Reload Register (TOP3RL)	10-72
H'0080 0274		(Use inhibited area)	
H'0080 0276		TOP3 Correction Register (TOP3CC)	10-73
		(Use inhibited area)	
H'0080 0280		TOP4 Counter (TOP4CT)	10-71
H'0080 0282		TOP4 Reload Register (TOP4RL)	10-72
H'0080 0284		(Use inhibited area)	
H'0080 0286		TOP4 Correction Register (TOP4CC)	10-73
		(Use inhibited area)	
H'0080 0290		TOP5 Counter (TOP5CT)	10-71
H'0080 0292		TOP5 Reload Register (TOP5RL)	10-72
H'0080 0294		(Use inhibited area)	
H'0080 0296		TOP5 Correction Register (TOP5CC)	10-73
H'0080 0298		(Use inhibited area)	



## TOP Related Register Map (2/2)

Address	+0 address		+1 address		See pages
	b0	b7	b8	b15	
H'0080 029A	TOP0–5 Control Register 0 (TOP05CR0)				10-67
H'0080 029C	(Use inhibited area)	TOP0–5 Control Register 1 (TOP05CR1)			10-67
	(Use inhibited area)				
H'0080 02A0	TOP6 Counter (TOP6CT)				10-71
H'0080 02A2	TOP6 Reload Register (TOP6RL)				10-72
H'0080 02A4	(Use inhibited area)				
H'0080 02A6	TOP6 Correction Register (TOP6CC)				10-73
H'0080 02A8	(Use inhibited area)				
H'0080 02AA	TOP6,7 Control Register (TOP67CR)				10-69
	(Use inhibited area)				
H'0080 02B0	TOP7 Counter (TOP7CT)				10-71
H'0080 02B2	TOP7 Reload Register (TOP7RL)				10-72
H'0080 02B4	(Use inhibited area)				
H'0080 02B6	TOP7 Correction Register (TOP7CC)				10-73
	(Use inhibited area)				
H'0080 02C0	TOP8 Counter (TOP8CT)				10-71
H'0080 02C2	TOP8 Reload Register (TOP8RL)				10-72
H'0080 02C4	(Use inhibited area)				
H'0080 02C6	TOP8 Correction Register (TOP8CC)				10-73
	(Use inhibited area)				
H'0080 02D0	TOP9 Counter (TOP9CT)				10-71
H'0080 02D2	TOP9 Reload Register (TOP9RL)				10-72
H'0080 02D4	(Use inhibited area)				
H'0080 02D6	TOP9 Correction Register (TOP9CC)				10-73
	(Use inhibited area)				
H'0080 02E0	TOP10 Counter (TOP10CT)				10-71
H'0080 02E2	TOP10 Reload Register (TOP10RL)				10-72
H'0080 02E4	(Use inhibited area)				
H'0080 02E6	TOP10 Correction Register (TOP10CC)				10-73
H'0080 02E8	(Use inhibited area)				
H'0080 02EA	TOP8–10 Control Register (TOP810CR)				10-70
	(Use inhibited area)				
H'0080 02FA	TOP0–10 External Enable Permit Register (TOPEEN)				10-74
H'0080 02FC	TOP0–10 Enable Protect Register (TOPPRO)				10-74
H'0080 02FE	TOP0–10 Count Enable Register (TOPCEN)				10-75

#### 10.3.4 TOP Control Registers

The TOP control registers are used to select operation modes of TOP0–10 (single-shot output, delayed single-shot output or continuous output mode), as well as select the count enable and count clock sources. Following four TOP control registers are provided for each timer group.

- TOP0–5 Control Register 0 (TOP05CR0)
- TOP0–5 Control Register 1 (TOP05CR1)
- TOP6,7 Control Register (TOP67CR)
- TOP8–10 Control Register (TOP810CR)

TOP0–5 Control Register 0 (TOP05CR0)

<Address: H'0080 029A>

b0	1	2	3	4	5	6	7	8	9	10	11	12	13	14	b15
TOP3M		TOP2M		TOP1M		TOP0M			TOP05ENS					TOP05CKS	
0	0	0	0	0	0	0	0	0	0	0	0	0	0	0	0

<Upon exiting reset: H'0000>

b	Bit Name	Function	R	W
0, 1	TOP3M (TOP3 operation mode select bit)	00: Single-shot output mode	R	W
2, 3	TOP2M (TOP2 operation mode select bit)	01: Delayed single-shot output mode		
4, 5	TOP1M (TOP1 operation mode select bit)	10: Continuous output mode		
6, 7	TOP0M (TOP0 operation mode select bit)	11: Continuous output mode		
8	No function assigned. Fix to "0."		0	0
9–11	TOP05ENS TOP0–5 enable source select bit	000: External TIN0 input 001: External TIN0 input 010: External TIN0 input 011: External TIN0 input 100: Input event bus 0 101: Input event bus 1 110: Input event bus 2 111: Input event bus 3	R	W
12, 13	No function assigned. Fix to "0."		0	0
14, 15	TOP05CKS TOP0–5 clock source select bit	00: Clock bus 0 01: Clock bus 1 10: Clock bus 2 11: Clock bus 3	R	W

Notes: • This register must always be accessed in halfwords.

- Operation mode can only be set or changed while the counter is inactive.

TOP0–5 Control Register 1 (TOP05CR1)

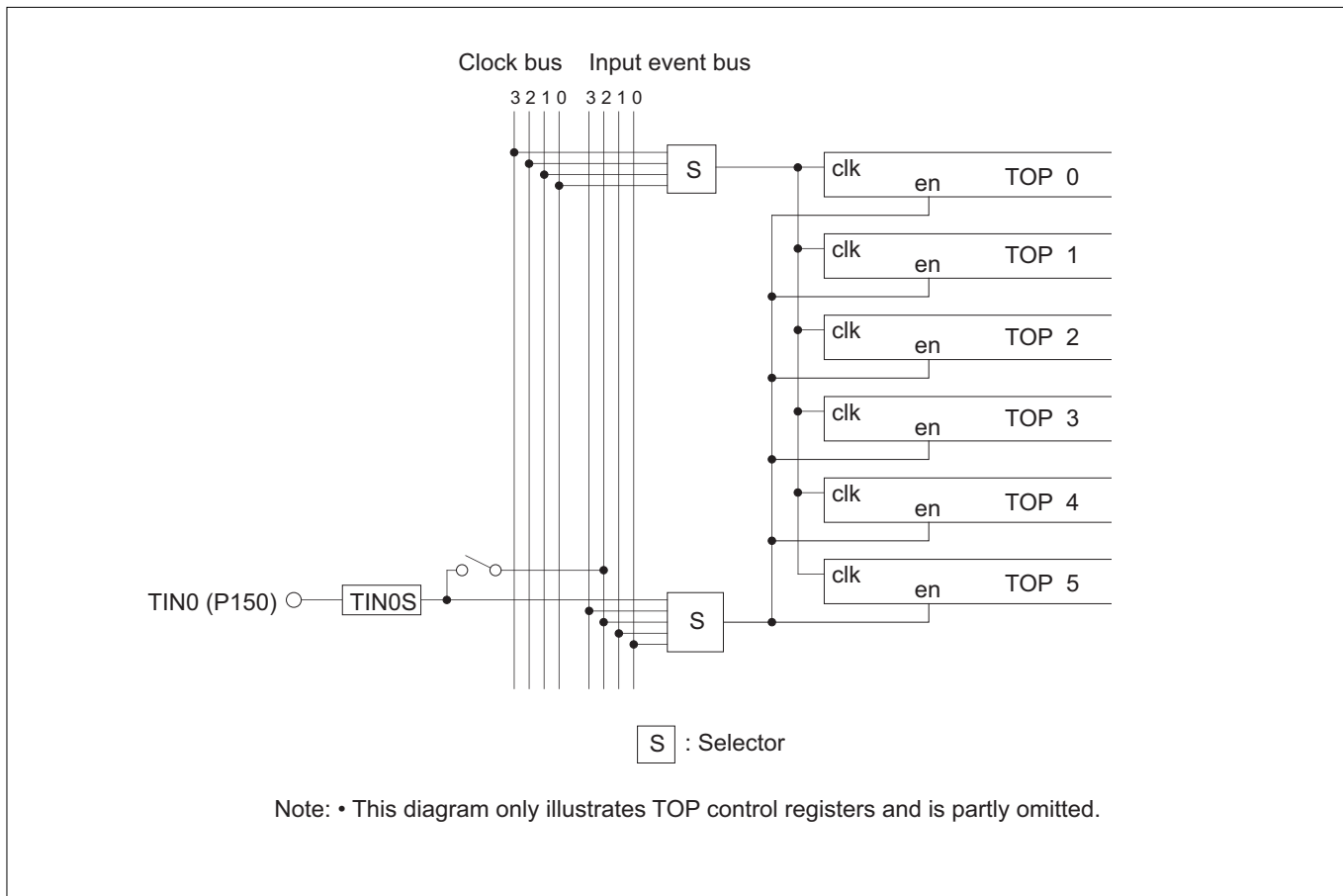
<Address: H'0080 029D>

b8	9	10	11	12	13	14	b15
				TOP5M		TOP4M	
0	0	0	0	0	0	0	0

<Upon exiting reset: H'00>

b	Bit Name	Function	R	W
8–11	No function assigned. Fix to "0."		0	0
12, 13	TOP5M (TOP5 operation mode select bit)	00: Single-shot output mode	R	W
14, 15	TOP4M (TOP4 operation mode select bit)	01: Delayed single-shot output mode 10: Continuous output mode 11: Continuous output mode		

Note: • Operation mode can only be set or changed while the counter is inactive.



**Figure 10.3.3 Outline Diagram of TOP0-5 Clock and Enable Inputs**

TOP6,7 Control Register (TOP67CR)

<Address: H'0080 02AA>

b0	1	2	3	4	5	6	7	8	9	10	11	12	13	14	b15
	TOP7ENS	TOP7M				TOP6M			TOP67ENS					TOP67CKS	
0	0	0	0	0	0	0	0	0	0	0	0	0	0	0	0

<Upon exiting reset: H'0000>

b	Bit Name	Function	R	W
0	No function assigned. Fix to "0."		0	0
1	TOP7ENS TOP7 enable source select bit	0: Result selected by TOP67ENS bit 1: TOP6 output	R	W
2, 3	TOP7M TOP7 operation mode select bit	00: Single-shot output mode 01: Delayed single-shot output mode 10: Continuous output mode 11: Continuous output mode	R	W
4, 5	No function assigned. Fix to "0."		0	0
6, 7	TOP6M TOP6 operation mode select bit	00: Single-shot output mode 01: Delayed single-shot output mode 10: Continuous output mode 11: Continuous output mode	R	W
8	No function assigned. Fix to "0."		0	0
9–11	TOP67ENS TOP6, TOP7 enable source select bit	000: Does not select the enable source 001: Does not select the enable source 010: Does not select the enable source 011: Does not select the enable source 100: Input event bus 0 101: Input event bus 1 110: Input event bus 2 111: Input event bus 3	R	W
12, 13	No function assigned. Fix to "0."		0	0
14, 15	TOP67CKS TOP6, TOP7 clock source select bit	00: Clock bus 0 01: Clock bus 1 10: Clock bus 2 11: Clock bus 3	R	W

Notes: • This register must always be accessed in halfwords.

- Operation mode can only be set or changed while the counter is inactive.

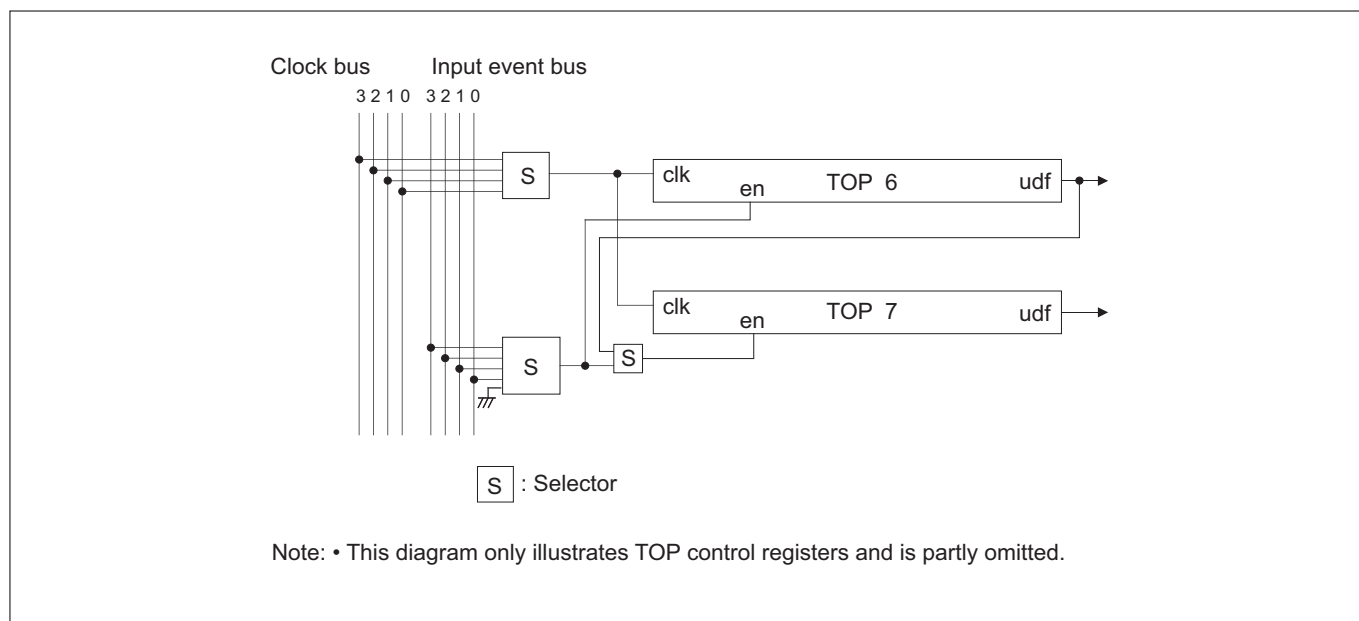


Figure 10.3.4 Outline Diagram of TOP6, TOP7 Clock and Enable Inputs

TOP8–10 Control Register (TOP810CR)

<Address: H'0080 02EA>

b0	1	2	3	4	5	6	7	8	9	10	11	12	13	14	b15
TOP10M		TOP9M		TOP8M		TOP810ENS		TOP810CKS							
0	0	0	0	0	0	0	0	0	0	0	0	0	0	0	0

<Upon exiting reset: H'0000>

b	Bit Name	Function	R	W
0, 1	No function assigned. Fix to "0."		0	0
2, 3	TOP10M (TOP10 operation mode select bit)	00: Single-shot output mode	R	W
4, 5	TOP9M (TOP9 operation mode select bit)	01: Delayed single-shot output mode		
6, 7	TOP8M (TOP8 operation mode select bit)	10: Continuous output mode 11: Continuous output mode		
8–10	No function assigned. Fix to "0."		0	0
11	TOP810ENS TOP8–10 enable source select bit	0: Does not select the enable source 1: Input event bus 3	R	W
12, 13	No function assigned. Fix to "0."		0	0
14, 15	TOP810CKS TOP8–10 clock source select bit	00: Clock bus 0 01: Clock bus 1 10: Clock bus 2 11: Clock bus 3	R	W

Notes: • This register must always be accessed in halfwords.

- Operation mode can only be set or changed while the counter is inactive.

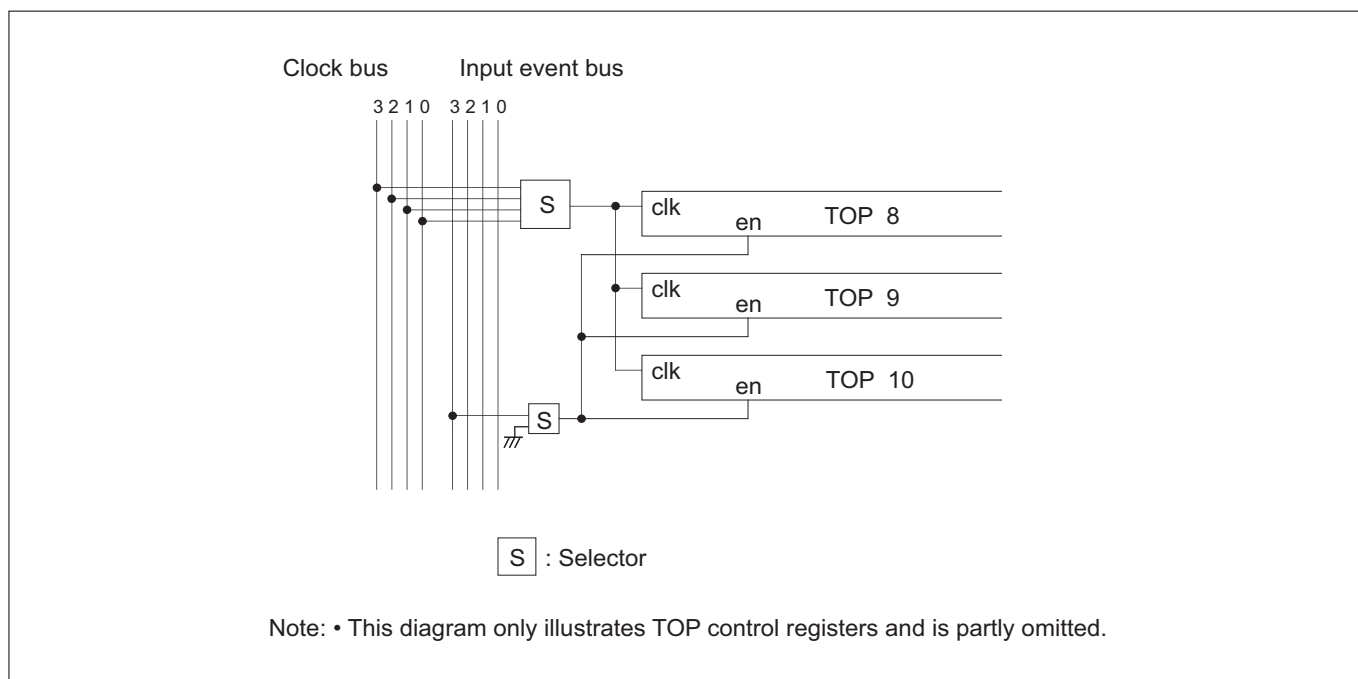
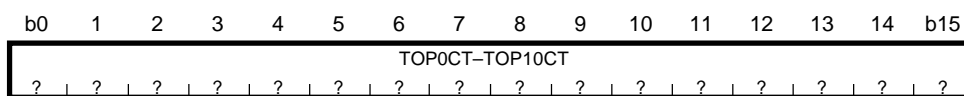


Figure 10.3.5 Outline Diagram of TOP8–10 Clock and Enable Inputs

#### 10.3.5 TOP Counters (TOP0CT–TOP10CT)

TOP0 Counter (TOP0CT)	<Address: H'0080 0240>
TOP1 Counter (TOP1CT)	<Address: H'0080 0250>
TOP2 Counter (TOP2CT)	<Address: H'0080 0260>
TOP3 Counter (TOP3CT)	<Address: H'0080 0270>
TOP4 Counter (TOP4CT)	<Address: H'0080 0280>
TOP5 Counter (TOP5CT)	<Address: H'0080 0290>
TOP6 Counter (TOP6CT)	<Address: H'0080 02A0>
TOP7 Counter (TOP7CT)	<Address: H'0080 02B0>
TOP8 Counter (TOP8CT)	<Address: H'0080 02C0>
TOP9 Counter (TOP9CT)	<Address: H'0080 02D0>
TOP10 Counter (TOP10CT)	<Address: H'0080 02E0>



<Upon exiting reset: Undefined>

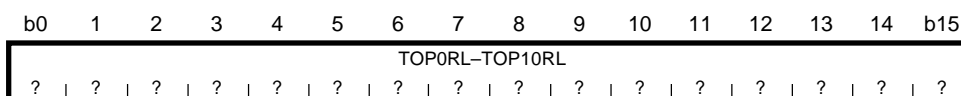
b	Bit Name	Function	R	W
0–15	TOP0CT–TOP10CT	16-bit counter value	R	W

Note: • These registers must always be accessed in halfwords.

The TOP counters are a 16-bit down-counter. After the timer is enabled (by writing to the enable bit in software or by external input), the counter starts counting synchronously with the count clock.

#### 10.3.6 TOP Reload Registers (TOP0RL–TOP10RL)

TOP0 Reload Register (TOP0RL)	<Address: H'0080 0242>
TOP1 Reload Register (TOP1RL)	<Address: H'0080 0252>
TOP2 Reload Register (TOP2RL)	<Address: H'0080 0262>
TOP3 Reload Register (TOP3RL)	<Address: H'0080 0272>
TOP4 Reload Register (TOP4RL)	<Address: H'0080 0282>
TOP5 Reload Register (TOP5RL)	<Address: H'0080 0292>
TOP6 Reload Register (TOP6RL)	<Address: H'0080 02A2>
TOP7 Reload Register (TOP7RL)	<Address: H'0080 02B2>
TOP8 Reload Register (TOP8RL)	<Address: H'0080 02C2>
TOP9 Reload Register (TOP9RL)	<Address: H'0080 02D2>
TOP10 Reload Register (TOP10RL)	<Address: H'0080 02E2>



<Upon exiting reset: Undefined>

b	Bit Name	Function	R	W
0–15	TOP0RL–TOP10RL	16-bit reload register value	R	W

Note: • This register must always be accessed in halfwords.

The TOP reload registers are used to load data into the TOP counters (TOP0CT~TOP10CT). The content of "the reload register -1" is loaded into the counter synchronously with the count clock at the following timing:

- At the next cycle when the counter is enabled in single-shot output mode
- At the next cycle when the counter underflowed in delayed single-shot or continuous output mode

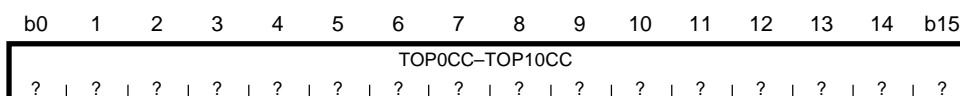
Simply because data is written to the reload register does not mean that the data is loaded into the counter. The counter is loaded with data in only the above cases.

Note that reloading of data after an underflow is performed synchronously with a clock pulse at which the counter underflowed.



#### 10.3.7 TOP Correction Registers (TOP0CC–TOP10CC)

TOP0 Correction Register (TOP0CC)	<Address: H'0080 0246>
TOP1 Correction Register (TOP1CC)	<Address: H'0080 0256>
TOP2 Correction Register (TOP2CC)	<Address: H'0080 0266>
TOP3 Correction Register (TOP3CC)	<Address: H'0080 0276>
TOP4 Correction Register (TOP4CC)	<Address: H'0080 0286>
TOP5 Correction Register (TOP5CC)	<Address: H'0080 0296>
TOP6 Correction Register (TOP6CC)	<Address: H'0080 02A6>
TOP7 Correction Register (TOP7CC)	<Address: H'0080 02B6>
TOP8 Correction Register (TOP8CC)	<Address: H'0080 02C6>
TOP9 Correction Register (TOP9CC)	<Address: H'0080 02D6>
TOP10 Correction Register (TOP10CC)	<Address: H'0080 02E6>



(Acceptable range of values: +32,767 to –32,768)

<Upon exiting reset: Undefined>

b	Bit Name	Function	R	W
0–15	TOP0CC–TOP10CC	16-bit correction register value	R	W

Note: • These registers must always be accessed in halfwords.

The TOP correction registers are used to correct the TOP counter value by adding or subtracting in the middle of operation. To increase or reduce the counter value, write to this correction register a value by which the counter value is to be increased or reduced from its initial set value. To add, write the value to be added to the correction register directly as is. To subtract, write the 2's complement of the value to be subtracted to the correction register.

The counter is corrected synchronously with a clock pulse next to one at which the correction value was written to the TOP correction register. If the counter is corrected this way, note that because one down count in that clock period is canceled, the counter value actually is corrected by "correction register value + 1." For example, if the initial counter value is 10 and the value 3 is written to the correction register when the counter has counted down to 5, then the counter counts a total of 15 before it underflows.

## 10.3.8 TOP Enable Control Registers

TOP0–10 External Enable Permit Register (TOPEEN)

&lt;Address: H'0080 02FA&gt;

b0	1	2	3	4	5	6	7	8	9	10	11	12	13	14	b15
					TOP10 EEN	TOP9 EEN	TOP8 EEN	TOP7 EEN	TOP6 EEN	TOP5 EEN	TOP4 EEN	TOP3 EEN	TOP2 EEN	TOP1 EEN	TOP0 EEN
0					0	0	0	0	0	0	0	0	0	0	0

&lt;Upon exiting reset: H'0000&gt;

b	Bit Name	Function	R	W
0–4	No function assigned. Fix to "0."		0	0
5	TOP10EEN (TOP10 external enable permit bit)	0: Disable external enable	R	W
6	TOP9EEN (TOP9 external enable permit bit)	1: Enable external enable		
7	TOP8EEN (TOP8 external enable permit bit)			
8	TOP7EEN (TOP7 external enable permit bit)			
9	TOP6EEN (TOP6 external enable permit bit)			
10	TOP5EEN (TOP5 external enable permit bit)			
11	TOP4EEN (TOP4 external enable permit bit)			
12	TOP3EEN (TOP3 external enable permit bit)			
13	TOP2EEN (TOP2 external enable permit bit)			
14	TOP1EEN (TOP1 external enable permit bit)			
15	TOP0EEN (TOP0 external enable permit bit)			

Note: • This register must always be accessed in halfwords.

The TOP0–10 External Enable Permit Register controls enable operation on TOP counters from external devices by enabling or disabling it.

TOP0–10 Enable Protect Register (TOPPRO)

&lt;Address: H'0080 02FC&gt;

b0	1	2	3	4	5	6	7	8	9	10	11	12	13	14	b15
					TOP10 PRO	TOP9 PRO	TOP8 PRO	TOP7 PRO	TOP6 PRO	TOP5 PRO	TOP4 PRO	TOP3 PRO	TOP2 PRO	TOP1 PRO	TOP0 PRO
0					0	0	0	0	0	0	0	0	0	0	0

&lt;Upon exiting reset: H'0000&gt;

b	Bit Name	Function	R	W
0–4	No function assigned. Fix to "0."		0	0
5	TOP10PRO (TOP10 enable protect bit)	0: Enable for rewriting	R	W
6	TOP9PRO (TOP9 enable protect bit)	1: Protect against rewriting		
7	TOP8PRO (TOP8 enable protect bit)			
8	TOP7PRO (TOP7 enable protect bit)			
9	TOP6PRO (TOP6 enable protect bit)			
10	TOP5PRO (TOP5 enable protect bit)			
11	TOP4PRO (TOP4 enable protect bit)			
12	TOP3PRO (TOP3 enable protect bit)			
13	TOP2PRO (TOP2 enable protect bit)			
14	TOP1PRO (TOP1 enable protect bit)			
15	TOP0PRO (TOP0 enable protect bit)			

Note: • This register must always be accessed in halfwords.

The TOP0–10 Enable Protect Register controls rewriting of the TOP count enable bit by enabling for or protecting it against rewriting.

TOP0–10 Count Enable Register (TOPCEN)

<Address: H'0080 02FE>

b0	1	2	3	4	5	6	7	8	9	10	11	12	13	14	b15
0	0	0	0	0	TOP10 CEN 0	TOP9 CEN 0	TOP8 CEN 0	TOP7 CEN 0	TOP6 CEN 0	TOP5 CEN 0	TOP4 CEN 0	TOP3 CEN 0	TOP2 CEN 0	TOP1 CEN 0	TOP0 CEN 0

<Upon exiting reset: H'0000>

b	Bit Name	Function	R	W
0–4	No function assigned. Fix to "0."		0	0
5	TOP10CEN (TOP10 count enable bit)	0: Stop counting	R	W
6	TOP9CEN (TOP9 count enable bit)	1: Enable counting		
7	TOP8CEN (TOP8 count enable bit)			
8	TOP7CEN (TOP7 count enable bit)			
9	TOP6CEN (TOP6 count enable bit)			
10	TOP5CEN (TOP5 count enable bit)			
11	TOP4CEN (TOP4 count enable bit)			
12	TOP3CEN (TOP3 count enable bit)			
13	TOP2CEN (TOP2 count enable bit)			
14	TOP1CEN (TOP1 count enable bit)			
15	TOP0CEN (TOP0 count enable bit)			

Note: • This register must always be accessed in halfwords.

The TOP0–10 Count Enable Register controls operation of TOP counters. To enable any TOP counter in software, enable its corresponding enable protect bit for write and set the count enable bit by writing "1." To stop any TOP counter, enable its corresponding enable protect bit for write and reset the count enable bit by writing "0."

In all but continuous output mode, when the counter stops due to occurrence of an underflow, the count enable bit is automatically reset to "0." Therefore, the TOP0-10 Count Enable Register when accessed for read serves as a status register indicating whether the counter is operating or idle.

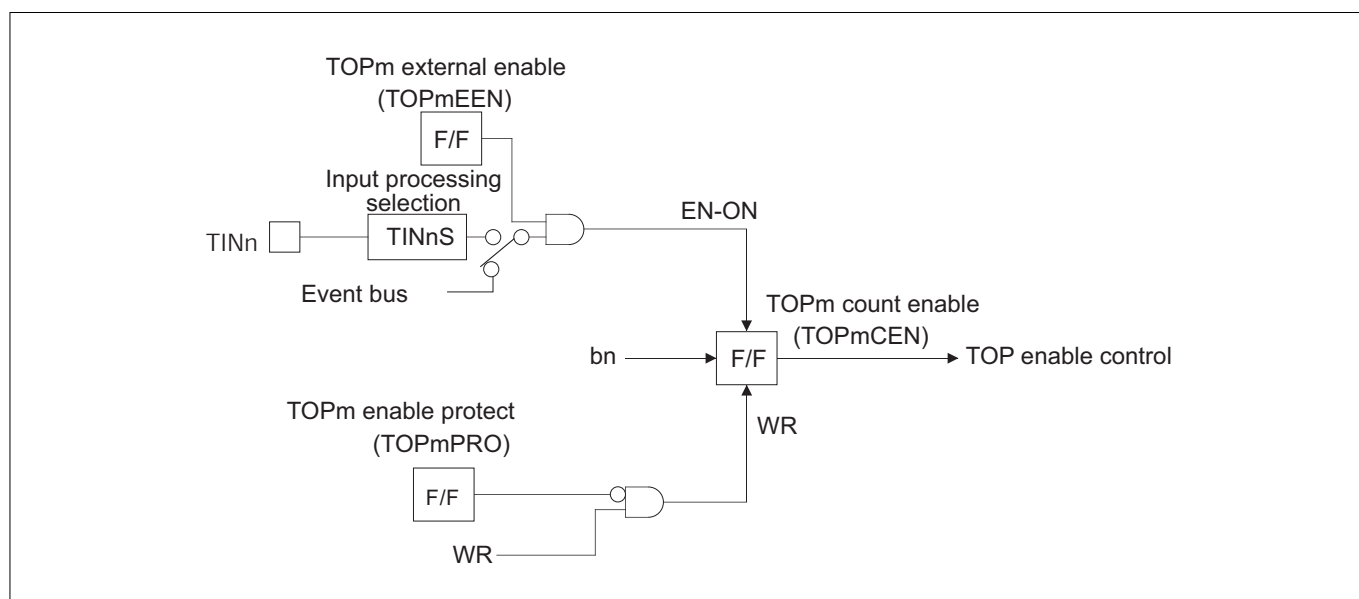


Figure 10.3.6 Configuration of the TOP Enable Circuit

## 10.3.9 Operation in TOP Single-shot Output Mode (with Correction Function)

## (1) Outline of TOP single-shot output mode

In single-shot output mode, the timer generates a pulse in width of "reload register set value+1" only once and then stops.

When the timer is enabled (by writing to the enable bit in software or by external input) after setting the reload register, at the next cycle the counter is loaded with the content of "the reload register -1" and starts counting synchronously with the count clock. The counter counts down and stops when it underflows after reaching the minimum count.

The F/F output waveform in single-shot output mode is inverted (F/F output levels change from "L" to "H" or vice versa) at startup and upon underflow, generating a single-shot pulse waveform in width of "reload register set value + 1" only once. An interrupt request can be generated when the counter underflows. The count value is "reload register set value + 1."

For example, if the initial reload register value is 7, then the count value is 8.

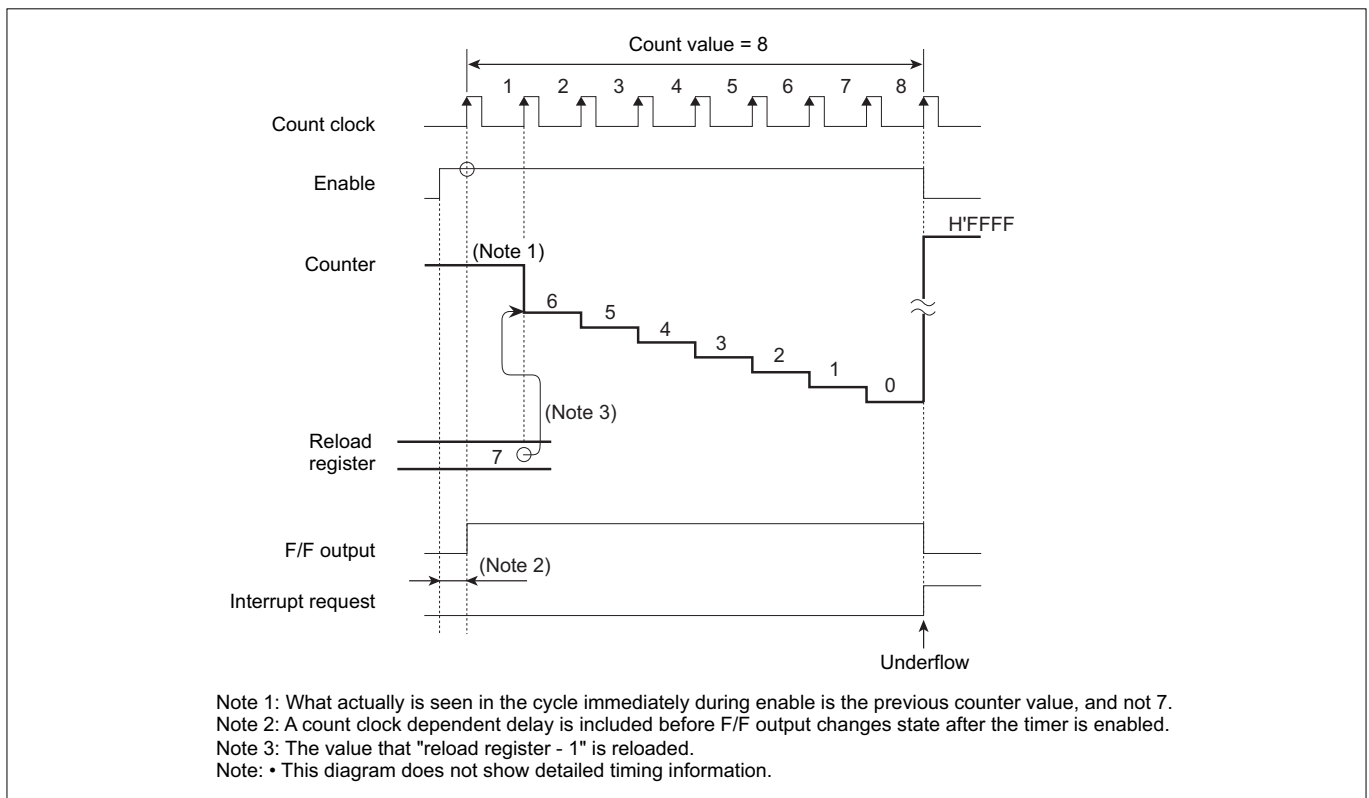
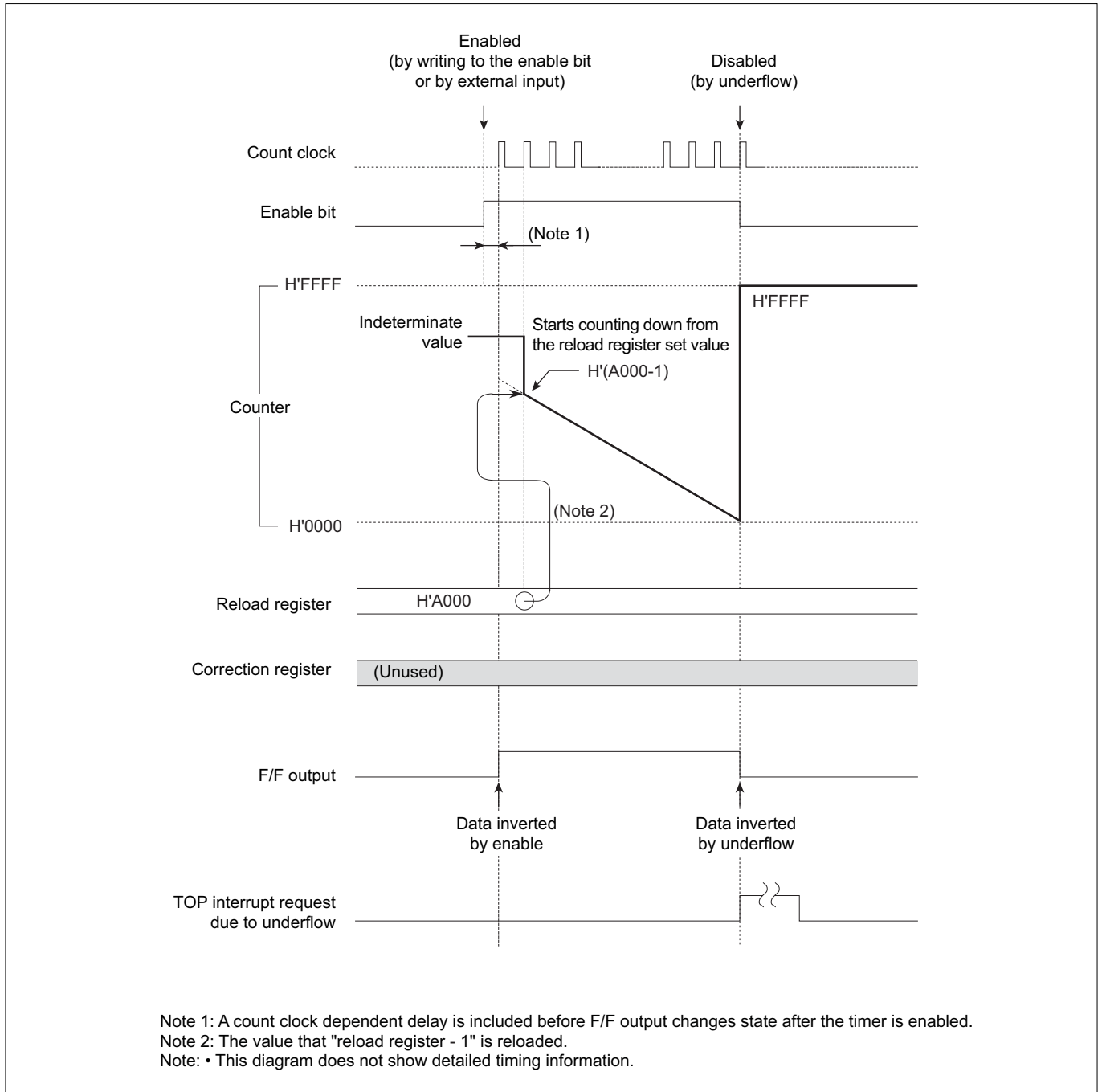


Figure 10.3.7 Example of Counting in TOP Single-shot Output Mode

In the example below, the reload register is initially set to H'A000. (The initial counter value can be undefined, and does not have to be specific.) When the timer starts, the value that "the reload register - 1" is loaded into the counter, letting it start counting. Thereafter, it continues counting down until it underflows after reaching the minimum count.



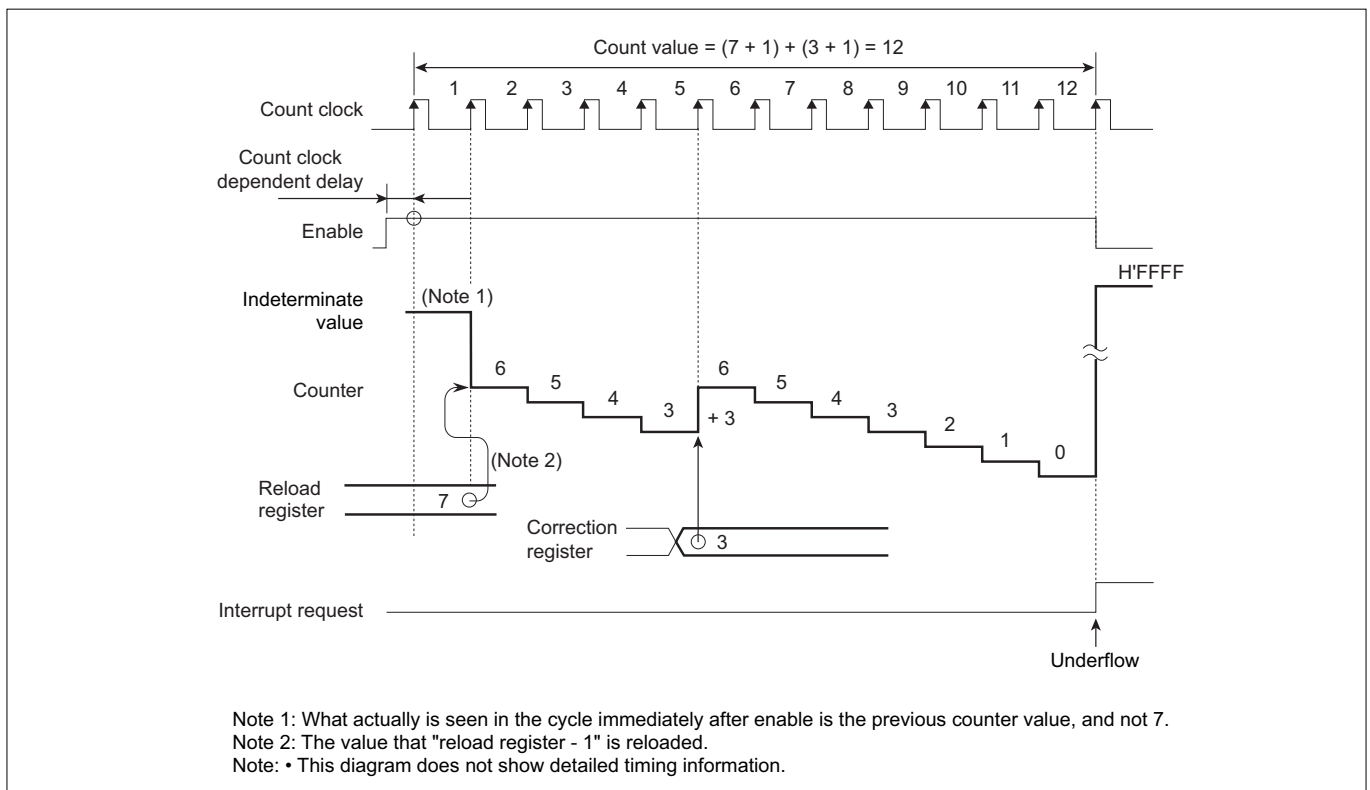
**Figure 10.3.8 Typical Operation in TOP Single-shot Output Mode**

**(2) Correction function of TOP single-shot output mode**

To change the counter value while in progress, write to the TOP correction register a value by which the counter value is to be increased or reduced from its initial set value. To add, write the value to be added to the correction register directly as is. To subtract, write the 2's complement of the value to be subtracted to the correction register.

The counter is corrected synchronously with a count clock pulse next to one at which the correction value was written to the TOP correction register. If the counter is corrected this way, note that because one down count in that clock period is canceled, the counter value actually is corrected by "correction register value + 1."

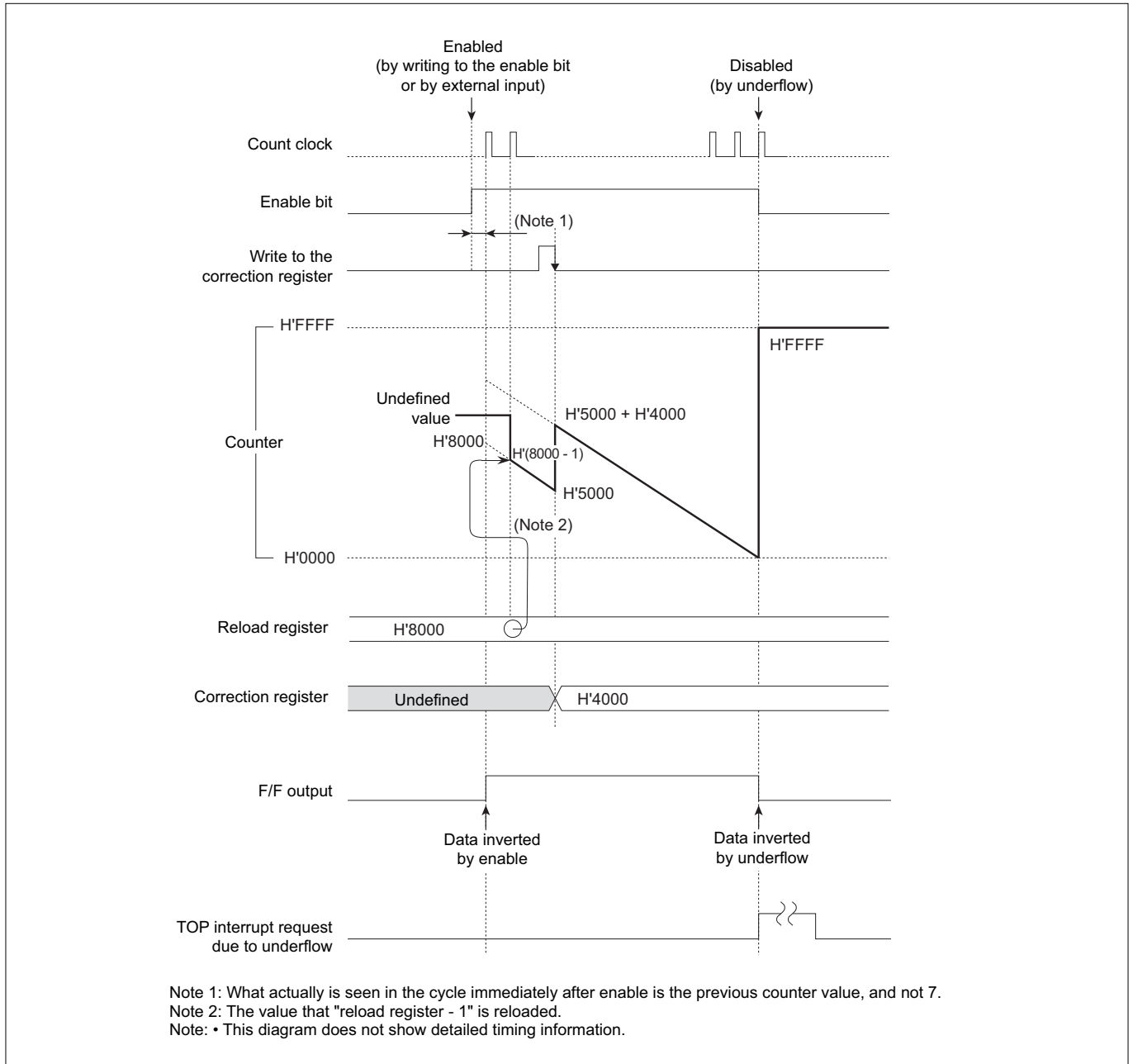
For example, if the initial counter value is 7 and the value 3 is written to the correction register when the counter has counted down to 3, then the counter counts a total of 12 before it underflows.



**Figure 10.3.9 Example of Counting in TOP Single-shot Output Mode When Count is Corrected**

When writing to the correction register, be careful not to cause the counter to overflow. Even if the counter overflows due to correction of counts, no interrupt requests are generated for reasons of an overflow.

In the example below, the reload register is initially set to H'8000. When the timer starts, the value that "the reload register - 1" is loaded into the counter, letting it start counting down. In the diagram below, the value H'4000 is written to the correction register when the counter has counted down to H'5000. As a result of this correction, the count has been increased to H'9000, so that the counter counts a total of  $(H'8000 + 1 + H'4000 + 1)$  before it stops.



**Figure 10.3.10 Typical Operation in TOP Single-shot Output Mode When Count is Corrected**

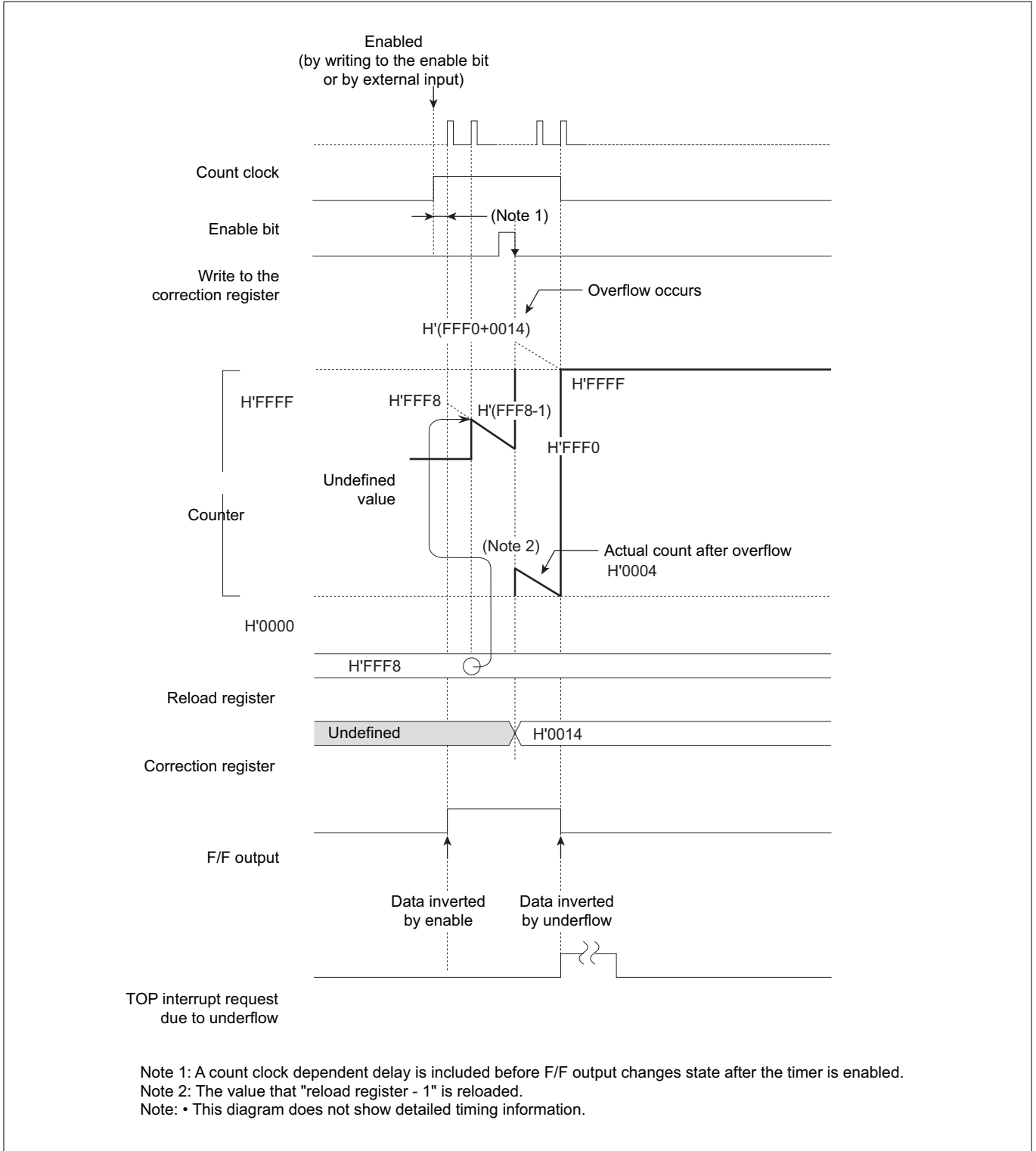
**(3) Notes on using TOP single-shot output mode**

The following describes precautions to be observed when using TOP single-shot output mode.

- If the counter stops due to an underflow in the same clock period as the timer is enabled by external input, the former has priority so that the counter stops.
- If the counter stops due to an underflow in the same clock period as count is enabled by writing to the enable bit, the latter has priority so that count is enabled.
- If the timer is enabled by external input in the same clock period as count is disabled by writing to the enable bit, the latter has priority so that count is disabled.
- Because the timer operates synchronously with the count clock, a count clock-dependent delay is included before F/F output is inverted after the timer is enabled.
- When writing to the correction register, be careful not to cause the counter to overflow. Even if the counter overflows due to correction of counts, no interrupt requests are generated for reasons of an overflow. Therefore, if the counter underflows in the subsequent down-count after an overflow, a false interrupt request is generated for an underflow that includes the overflowed count.



In the example below, the reload register is initially set to H'FFF8. When the timer starts, the value that "the reload register - 1" is loaded into the counter, letting it start counting down. In the diagram below, the value H'0014 is written to the correction register when the counter has counted down to H'FFF0. As a result of this correction, the count overflows to H'0004 and the counter fails to count correctly. Also, an interrupt request is generated for an erroneous overflowed count.



**Figure 10.3.11 Example of an Operation in TOP Single-shot Output Mode Where Count Overflows Due to Correction**

## 10.3.10 Operation in TOP Delayed Single-shot Output Mode (with Correction Function)

## (1) Outline of TOP delayed single-shot output mode

In delayed single-shot output mode, the timer generates a pulse in width of "reload register set value + 1" after a finite time equal to "counter set value + 1" only once and then stops.

When the timer is enabled (by writing to the enable bit in software or by external input) after setting the counter and reload register, it starts counting down from the counter's set value synchronously with the count clock. At the cycle after the first time the counter underflows, it is loaded with the value that "the reload register - 1" and continues counting down. The counter stops when it underflows next time.

The F/F output waveform in delayed single-shot output mode is inverted (F/F output level changes from "L" to "H" or vice versa) when the counter underflows first time and next, generating a single-shot pulse waveform in width of "reload register set value + 1" after a finite time equal to "first set value of counter + 1" only once. An interrupt request can be generated when the counter underflows first time and next. The "counter set value + 1" and "reload register set value + 1" are effective as count values.

For example, if the initial counter value is 4 and the initial reload register value is 5, then the timer operates as shown below.

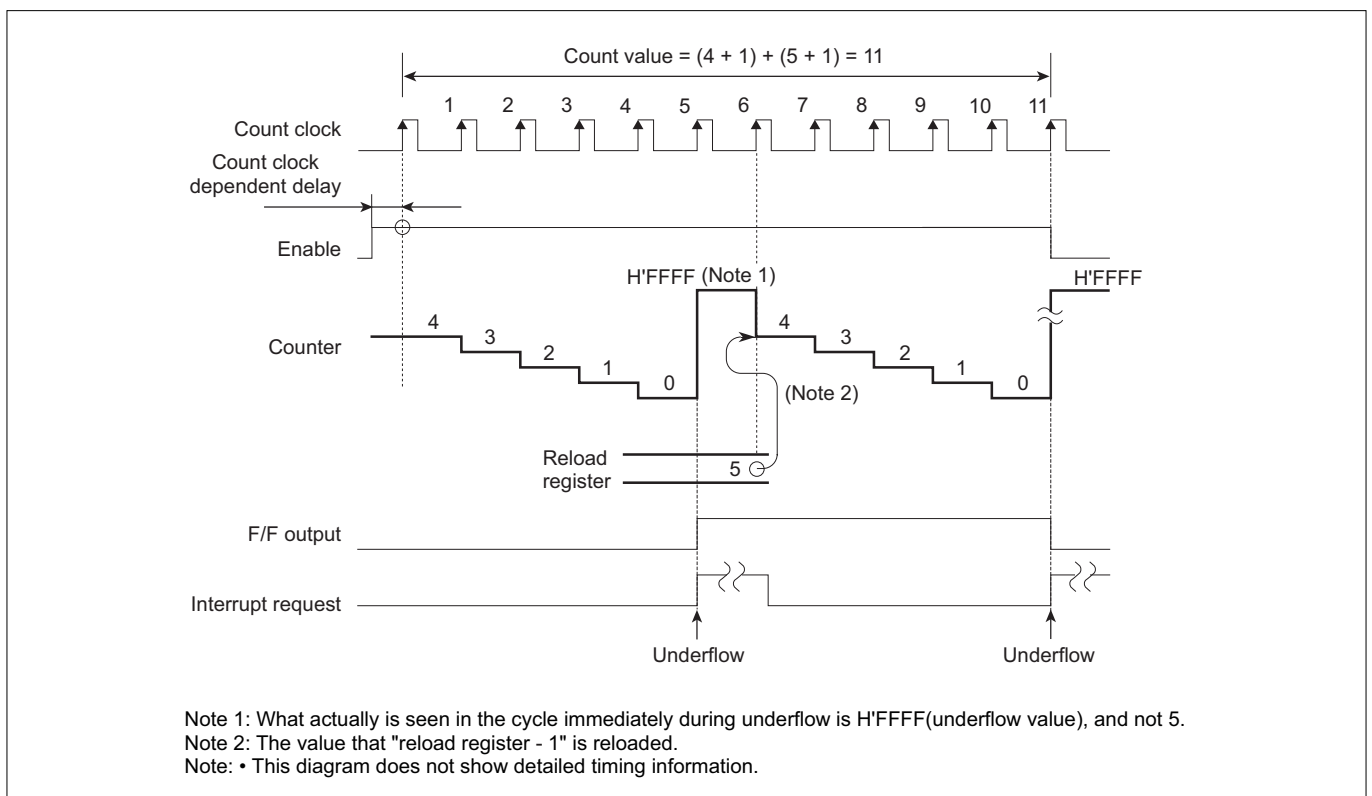
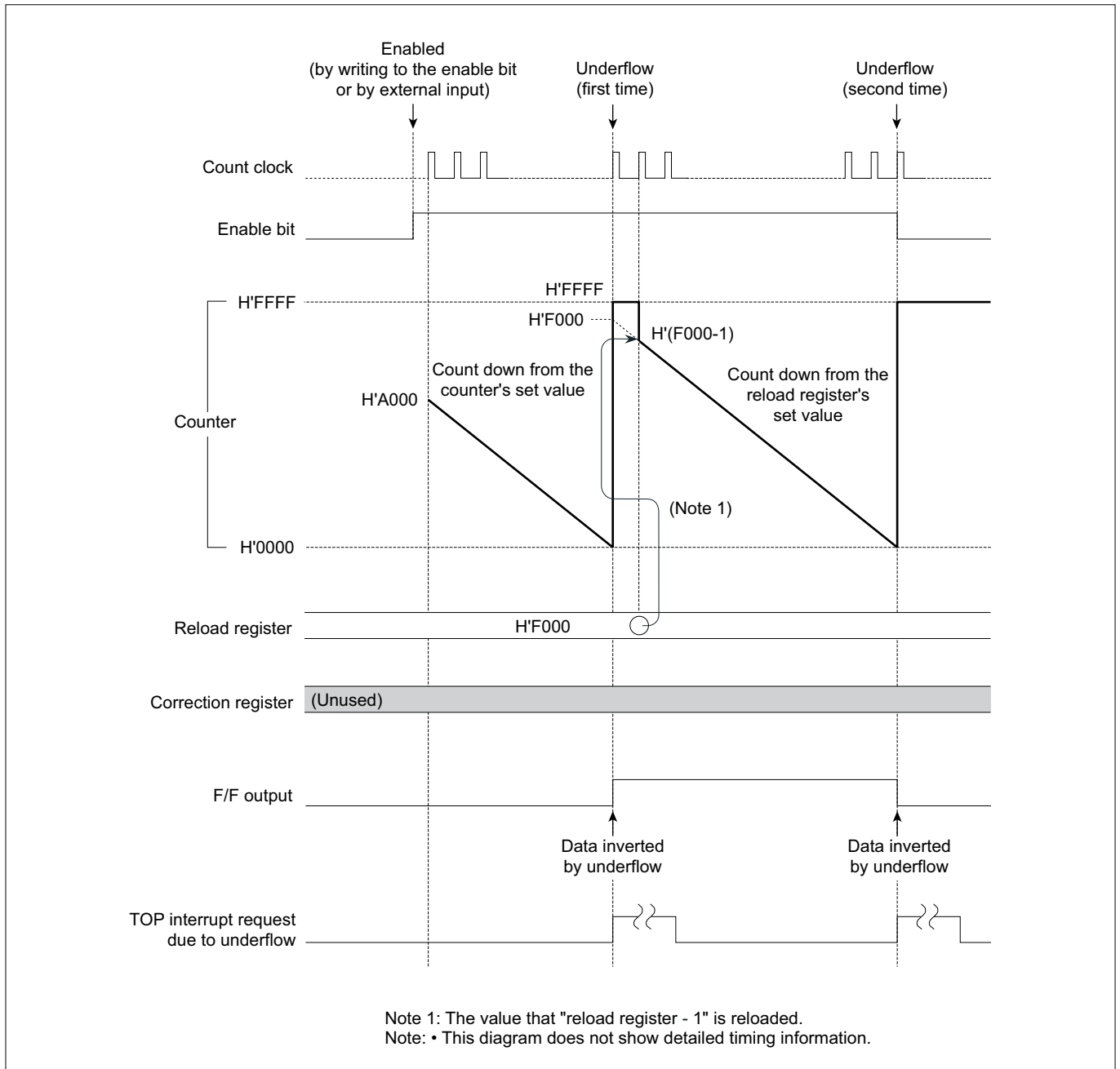


Figure 10.3.12 Example of Counting in TOP Delayed Single-shot Output Mode

In the example below, the counter and the reload register are initially set to H'A000 and H'F000, respectively. When the timer is enabled, the counter starts counting down and at the cycle after it underflows, the counter is loaded with the content of "the reload register - 1" and continues counting down. The counter stops when it underflows second time.



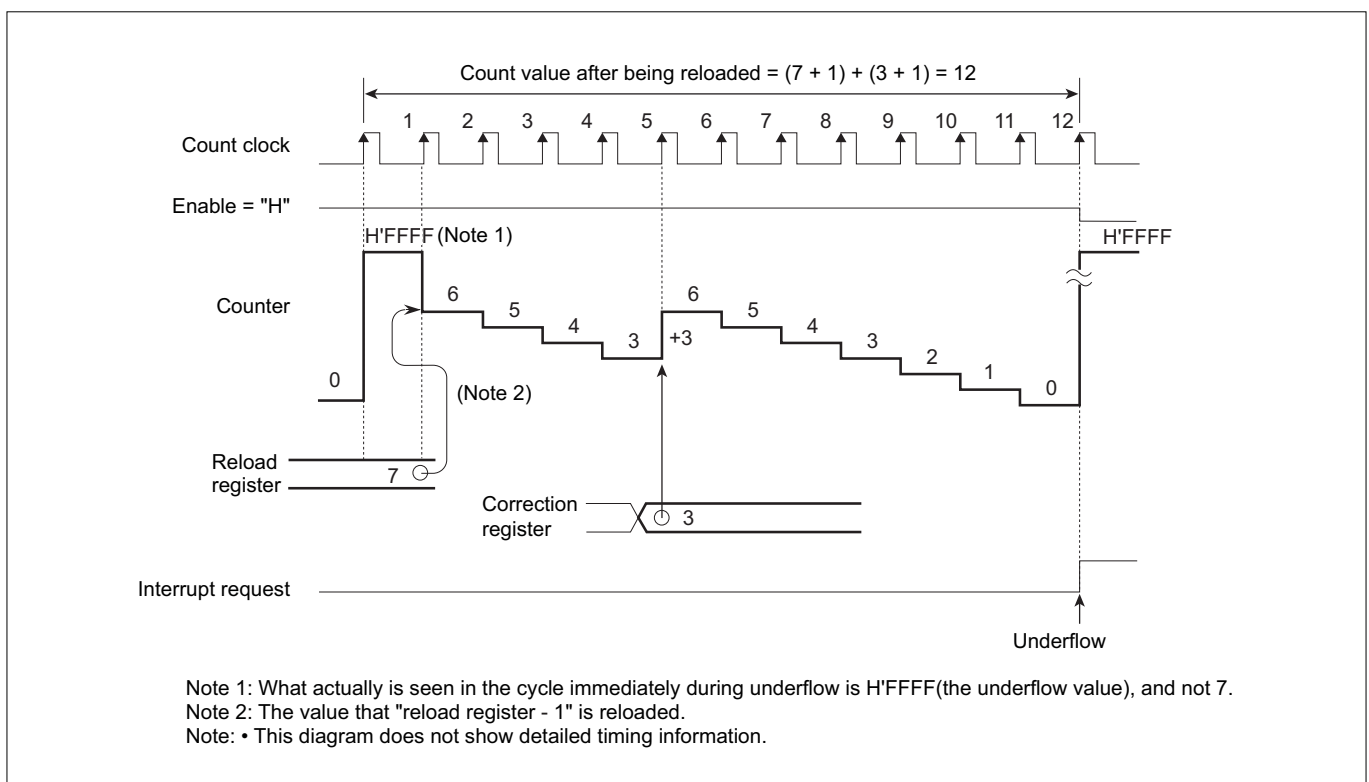
**Figure 10.3.13 Typical Operation in TOP Delayed Single-shot Output Mode**

**(2) Correction function of TOP delayed single-shot output mode**

To change the counter value while in progress, write to the TOP correction register a value by which the counter value is to be increased or reduced from its initial set value. To add, write the value to be added to the correction register directly as is. To subtract, write the 2's complement of the value to be subtracted to the correction register.

The counter is corrected synchronously with a count clock pulse next to one at which the correction value was written to the TOP correction register. If the counter is corrected this way, note that because one down count in that clock period is canceled, the counter value actually is corrected by "correction register value + 1."

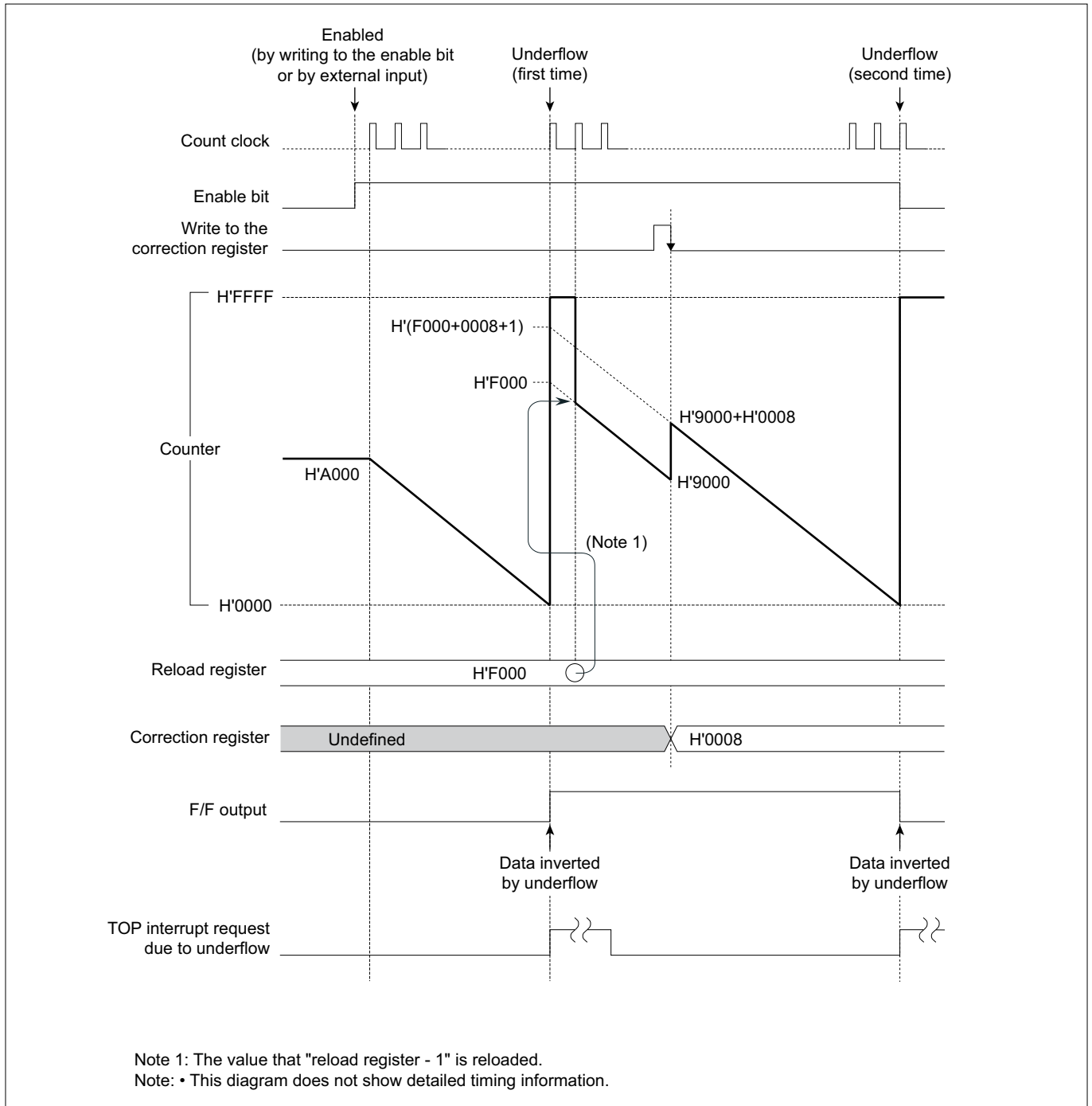
For example, if the reload register value is 7 and the value 3 is written to the correction register when the counter has counted down to 3 after being reloaded, then the counter counts a total of 12 after being reloaded before it underflows.



**Figure 10.3.14 Example of Counting in TOP Delayed Single-shot Output Mode When Count is Corrected**

When writing to the correction register, be careful not to cause the counter to overflow. Even if the counter overflows due to correction of counts, no interrupt requests are generated for reasons of an overflow.

In the example below, the counter and the reload register are initially set to H'A000 and H'F000, respectively. When the timer is enabled, the counter starts counting down and at the cycle after the first underflow, the counter is loaded with the content of "the reload register - 1" and continues counting down. In the diagram below, the value H'0008 is written to the correction register when the counter has counted down to H'9000. As a result of this correction, the counter has its count value increased to H'9008 and counts (H'F000 + 1 + H'0008 + 1) after the first underflow before it stops.

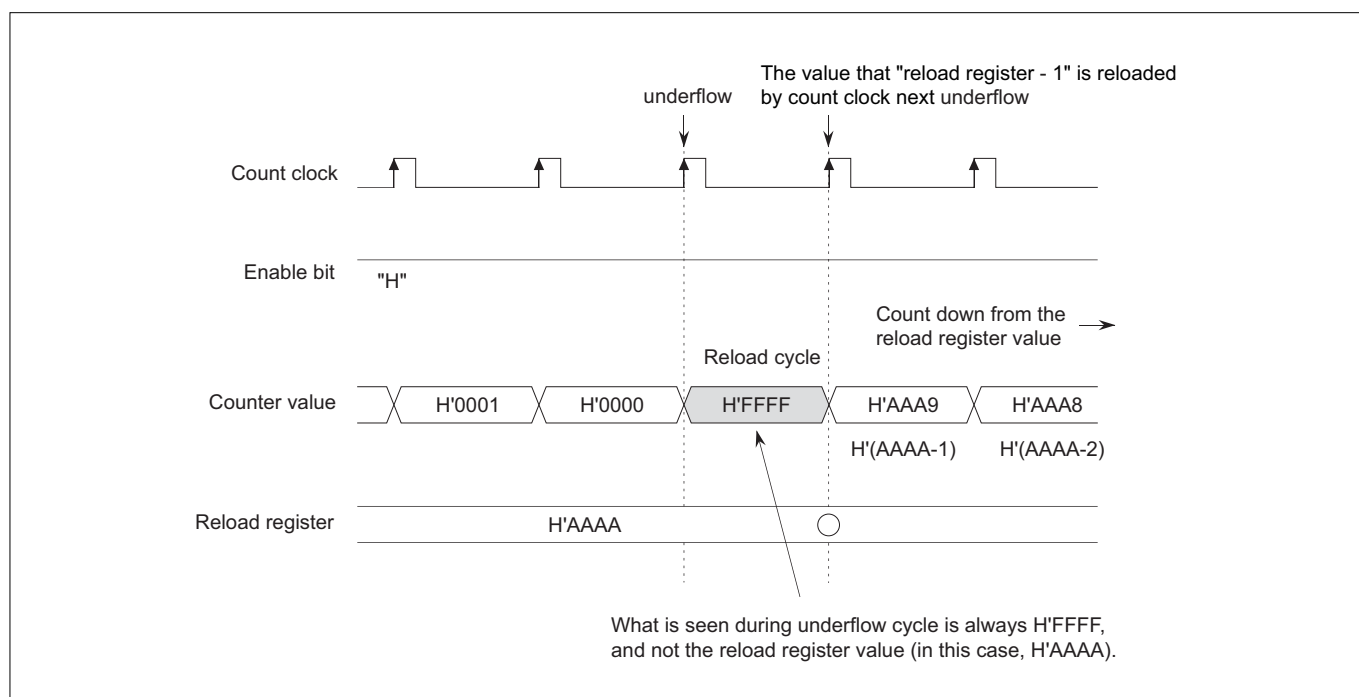


**Figure 10.3.15 Typical Operation in TOP Delayed Single-shot Output Mode when Count is Corrected**

**(3) Notes on using TOP delayed single-shot output mode**

The following describes precautions to be observed when using TOP delayed single-shot output mode.

- If the counter stops due to an underflow in the same clock period as the timer is enabled by external input, the former has priority so that the counter stops.
- If the counter stops due to an underflow in the same clock period as count is enabled by writing to the enable bit, the latter has priority so that count is enabled.
- If the timer is enabled by external input in the same clock period as count is disabled by writing to the enable bit, the latter has priority so that count is disabled.
- Even if the counter overflows due to correction of counts, no interrupt requests are generated for reasons of an overflow. Therefore, if the counter underflows in the subsequent down-count after an overflow, a false interrupt request is generated for an underflow that includes the overflowed count.
- If the counter is accessed for read at the cycle of underflow, the counter value is read as H'FFFF but changes to "reload register value - 1" at the next count clock timing after underflow.



**Figure 10.3.16 Counter Value Immediately after Underflow**

#### 10.3.11 Operation in TOP Continuous Output Mode (without Correction Function)

##### (1) Outline of TOP continuous output mode

In continuous output mode, the timer counts down starting from the set value of the counter and at the cycle after the counter underflows, it is loaded with the value that "the reload register - 1." Thereafter, this operation is repeated each time the counter underflows, thus generating consecutive pulses whose waveform is inverted in width of "reload register set value + 1."

When the timer is enabled (by writing to the enable bit in software or by external input) after setting the counter and reload register, it starts counting down from the counter's set value synchronously with the count clock and when the minimum count is reached, generates an underflow.

At the cycle after this underflow, the counter to be loaded with the content of "the reload register - 1" and count down over again. Thereafter, this operation is repeated each time an underflow occurs. To stop the counter, disable count by writing to the enable bit in software.

The F/F output waveform in continuous output mode is inverted (F/F output level changes from "L" to "H" or vice versa) at startup and upon underflow, generating a waveform of consecutive pulses until the timer stops counting. An interrupt request can be generated each time the counter underflows.

The "counter set value + 1" and "reload register set value + 1" are effective as count values.

For example, if the initial counter value is 4 and the initial reload register value is 5, then the timer operates as shown below.

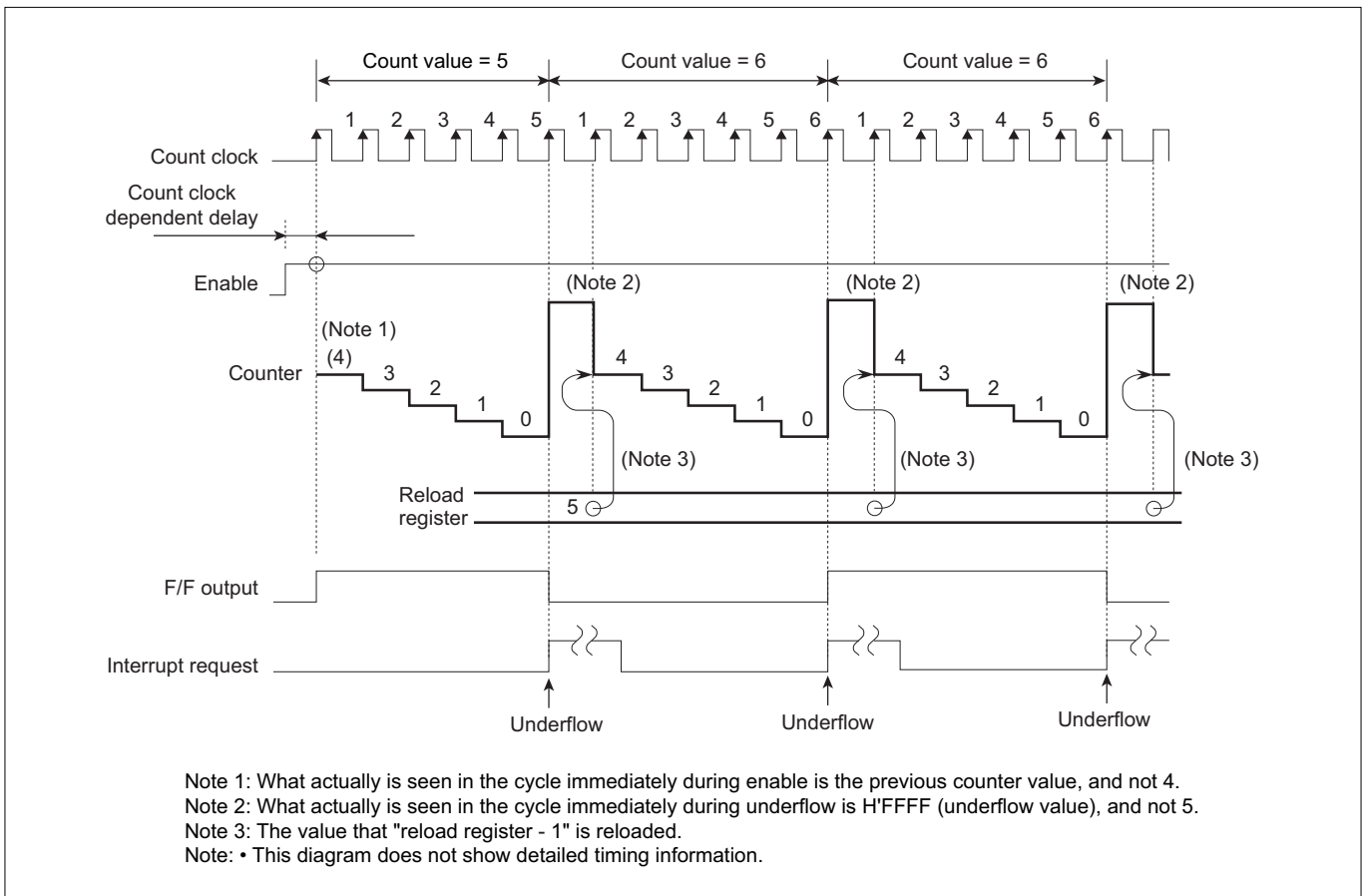
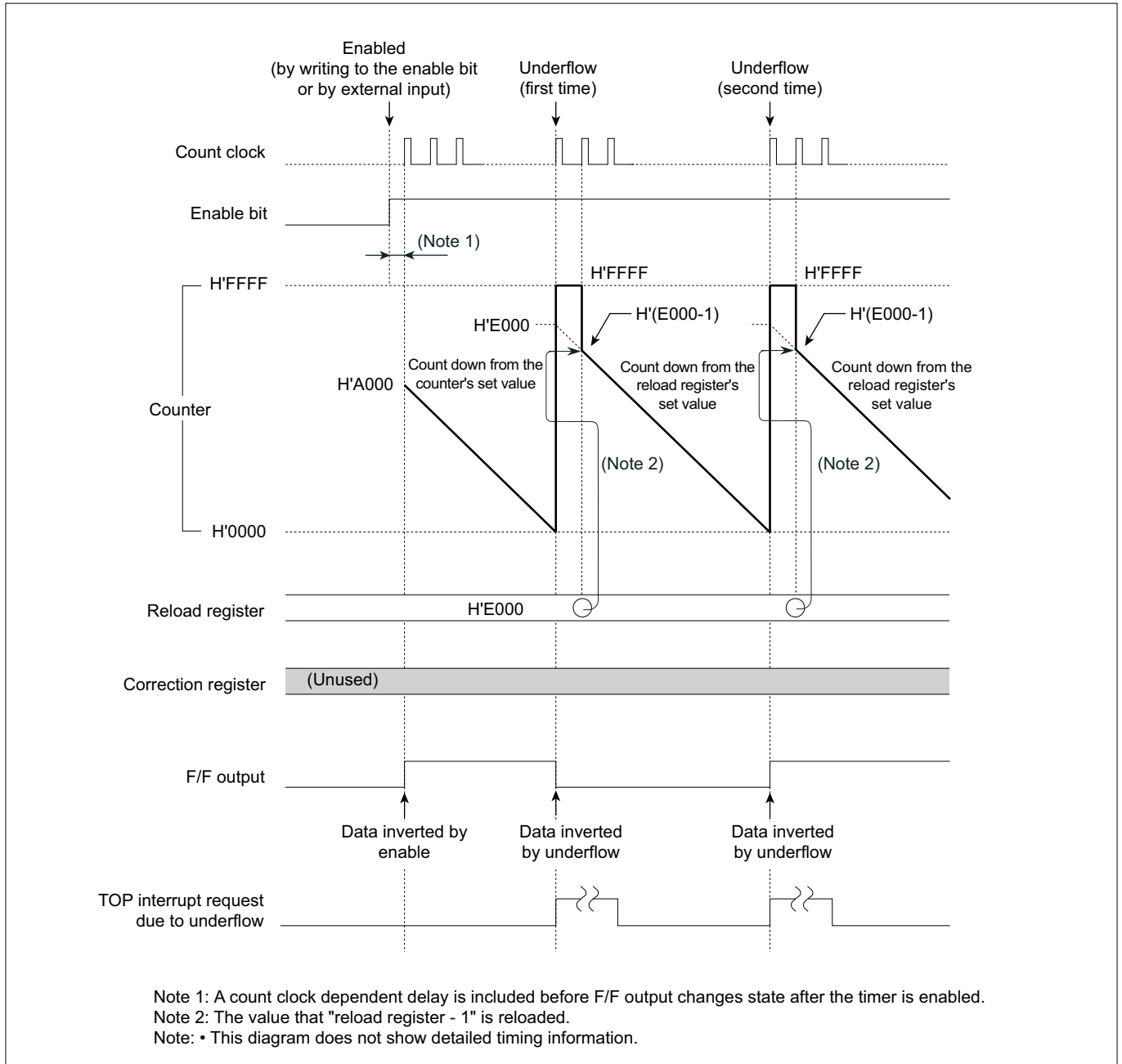


Figure 10.3.17 Example of Counting in TOP Continuous Output Mode

In the example below, the counter and the reload register are initially set to H'A000 and H'E000, respectively. When the timer is enabled, the counter starts counting down and when it underflows after reaching the minimum count, the counter is loaded with the content of "the reload register -1" and continues counting down. However the timing for reloading is at the cycle after underflow.



**Figure 10.3.18 Typical Operation in TOP Continuous Output Mode**



**(2) Notes on using TOP continuous output mode**

The following describes precautions to be observed when using TOP continuous output mode.

- If the timer is enabled by external input in the same clock period as count is disabled by writing to the enable bit, the latter has priority so that count is disabled.
- If the counter is accessed for read at the cycle of underflow, the counter value is read as H'FFFF but changes to "reload register value -1" at the next count clock timing.
- Because the timer operates synchronously with the count clock, a count clock-dependent delay is included before F/F output is inverted after the timer is enabled.

## 10.4 TIO (Input/Output-Related 16-Bit Timer)

### 10.4.1 Outline of TIO

TIO (Timer Input/Output) is an input/output-related 16-bit timer, whose operation mode can be selected from the following by mode switching in software, one at a time:

<Input modes>

- Measure clear input mode
- Measure free-run input mode
- Noise processing input mode

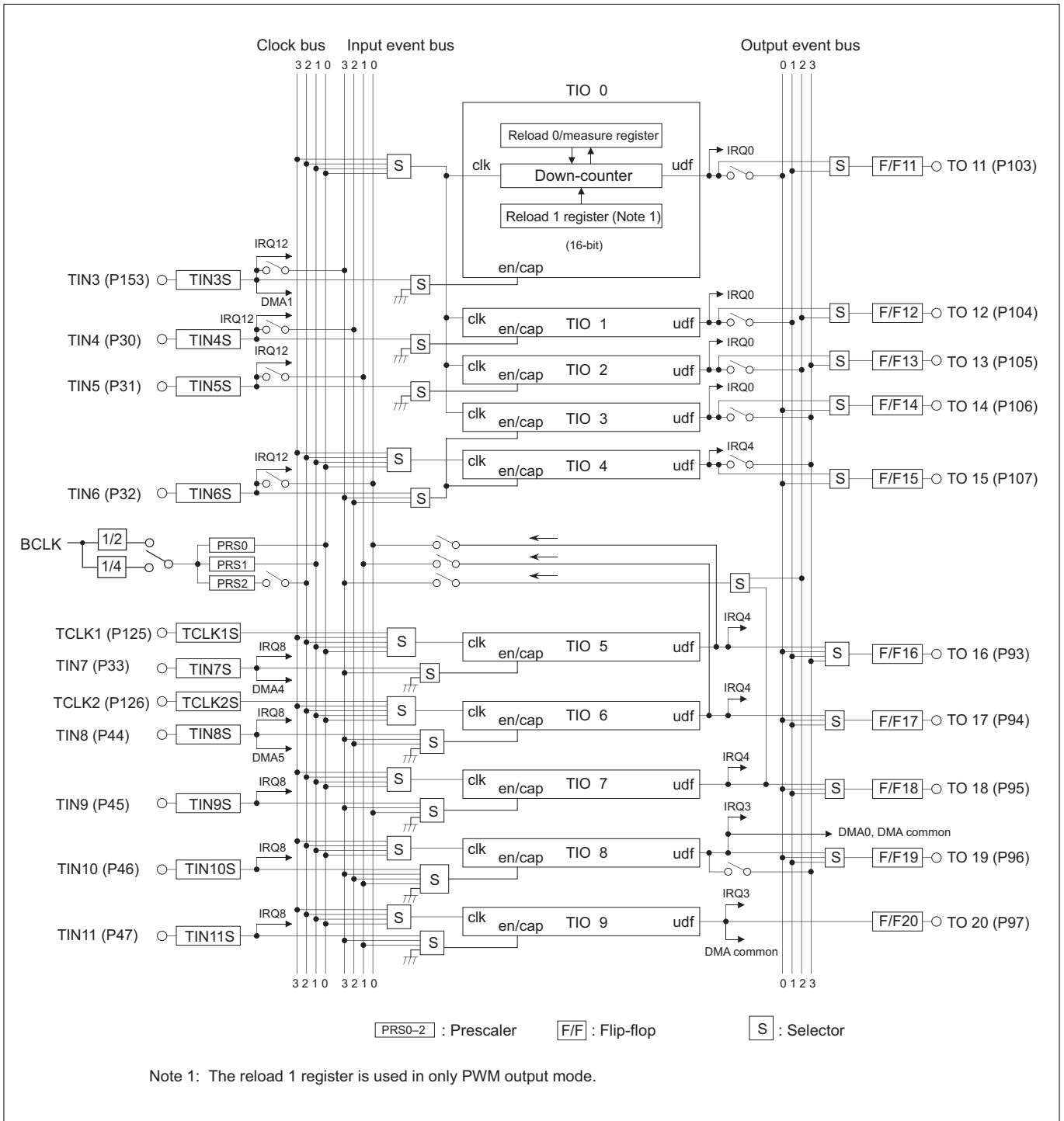
<Output modes without correction function>

- PWM output mode
- Single-shot output mode
- Delayed single-shot output mode
- Continuous output mode

The table below and the diagram in the next page show specifications and a block diagram of TIO, respectively.

**Table 10.4.1 Specifications of TIO (Input/Output-Related 16-Bit Timer)**

Item	Specification
Number of channels	10 channels
Counter	16-bit down-counter
Reload register	16-bit reload register
Measure register	16-bit capture register
Timer startup	Started by writing to the enable bit in software or enabled by external input (rising or falling or both edges or "H" or "L" level)
Operation mode	<Input modes> <ul style="list-style-type: none"> <li>• Measure clear input mode</li> <li>• Measure free-run input mode</li> <li>• Noise processing input mode</li> </ul> <Output modes without correction function> <ul style="list-style-type: none"> <li>• PWM output mode</li> <li>• Single-shot output mode</li> <li>• Delayed single-shot output mode</li> <li>• Continuous output mode</li> </ul>
Interrupt request generation	Can be generated by a counter underflow
DMA transfer request generation	Can be generated by a counter underflow (TIO8, TIO9 only)



**Figure 10.4.1 Block Diagram of TIO (Input/Output-Related 16-Bit Timer)**

### 10.4.2 Outline of Each Mode of TIO

Each mode of TIO is outlined below. For each TIO channel, only one of the following modes can be selected.

#### (1) Measure clear/free-run input modes

In measure clear/free-run input modes, the timer is used to measure a duration of time from when the counter starts counting until when an external capture signal is entered. And also it is possible to generate both an interrupt requested by underflow at the counter or execution of measurement operation and a DMA transfer request (for only the TIO8 and TIO9) upon underflow of the counter.

After the timer is enabled (by writing to the enable bit in software), the counter starts counting down synchronously with the count clock. When a capture signal is entered from an external device, the counter value at that point in time is written into a register called the "measure register."

In measure clear input mode, the counter value is initialized to H'FFFF upon capture, from which the counter starts counting down again. The counter returns to H'FFFF upon underflow, from which it starts counting down. Furthermore when it underflows goes back to H'FFFF and continues down counting.

In measure free-run input mode, the counter continues counting down even after capture. The counter returns to H'FFFF upon underflow, from which it starts counting down again.

To stop the counter, disable count by writing to the enable bit in software.

#### (2) Noise processing input mode

In noise processing input mode, the timer is used to detect that the input signal remained in the same state for over a predetermined time.

In noise processing input mode, a "H" or "L" level on external input activates the counter and if the input signal remains in the same state for over a predetermined time before the counter underflows, the counter generates an interrupt request before stopping. If the valid-level signal being applied turns to an invalid level before the counter underflows, the counter temporarily stops counting and at the next cycle when a valid-level signal is entered again, the counter is reloaded with the value that "the reload register -1" and restarts counting.

The timer stops at the same time the counter underflows or count is disabled by writing to the enable bit.

Furthermore, it is possible to generate an interrupt request and a DMA transfer request (for only the TIO8 and TIO9) upon underflow of the counter.

#### (3) PWM output mode (without correction function)

In PWM output mode, the timer uses two reload registers to generate a waveform with a given duty cycle.

When the timer is enabled (by writing to the enable bit in software or by external input) after setting the initial values in the reload 0 and reload 1 registers, the counter is loaded with the value that "the reload 0 register -1" and starts counting down synchronously with the count clock at the next cycle. The next cycle after the first time the counter underflows, it is loaded with the value that "the reload 1 register -1" and continues counting. Thereafter, the counter is loaded with the reload 0 and reload 1 register values alternately each time an underflow occurs. The effective counter value is "reload 0 register set value +1" or "reload 1 register set value +1".

The timer stops at the same time count is disabled by writing to the enable bit (and not in synchronism with PWM output period).

The F/F output waveform in PWM output mode is inverted (F/F output level changes from "L" to "H" or vice versa), when the counter starts counting and each time it underflows.

Furthermore, it is possible to generate an interrupt request at even-numbered occurrences of underflow after the counter is enabled and a DMA transfer request (for only the TIO8 and TIO9) every time the counter underflows.

In addition PWM output mode of TIO does not have function of correction.

**(4) Single-shot output mode (without correction function)**

In single-shot output mode, the timer generates a pulse in width of “reload 0 register set value + 1” only once and then stops.

When the timer is enabled (by writing to the enable bit in software or by external input) after setting the reload 0 register, the counter is loaded with the value that “the reload 0 register -1” and starts counting synchronously with the count clock at the next cycle. The counter counts down and when the minimum count is reached, stops upon underflow.

The F/F output waveform in single-shot output mode is inverted(F/F output level changes from "L" to "H" or vice versa) at startup and upon underflow, generating a single-shot pulse waveform in width of “reload 0 register set value + 1” only once.

Furthermore, it is possible to generate an interrupt request and a DMA transfer request (for only the TIO8 and TIO9) upon underflow of the counter.

**(5) Delayed single-shot output mode (without correction function)**

In delayed single-shot output mode, the timer generates a pulse in width of “reload 0 register set value + 1” after a finite time equal to “counter set value + 1” only once and then stops.

When the timer is enabled (by writing to the enable bit in software or by external input) after setting the counter and reload 0 register, it starts counting down from the counter's set value synchronously with the count clock.

The next cycle after the first time the counter underflows, it is loaded with the value that “the reload 0 register -1” and continues counting down. The counter stops when it underflows next time.

The F/F output waveform in delayed single-shot output mode is inverted(F/F output level changes from "L" to "H" or vice versa) when the counter underflows first time and next, generating a single-shot pulse waveform in width of “reload 0 register set value + 1” after a finite time equal to “first set value of counter + 1” only once.

Furthermore, it is possible to generate an interrupt request and a DMA transfer request (for only the TIO8 and TIO9) upon the first and next underflows of the counter.

**(6) Continuous output mode (without correction function)**

In continuous output mode, the timer counts down starting from the set value of the counter and when the counter underflows, it is loaded with the reload 0 register value. Thereafter, this operation is repeated each time the counter underflows, thus generating consecutive pulses in width of “reload 0 register set value + 1”.

When the timer is enabled (by writing to the enable bit in software or by external input) after setting the counter and reload 0 register, it starts counting down from the counter's set value synchronously with the count clock and when the minimum count is reached, generates an underflow.

The next cycle after this underflow causes the counter to be loaded with the content of “the reload 0 register -1” and start counting over again.

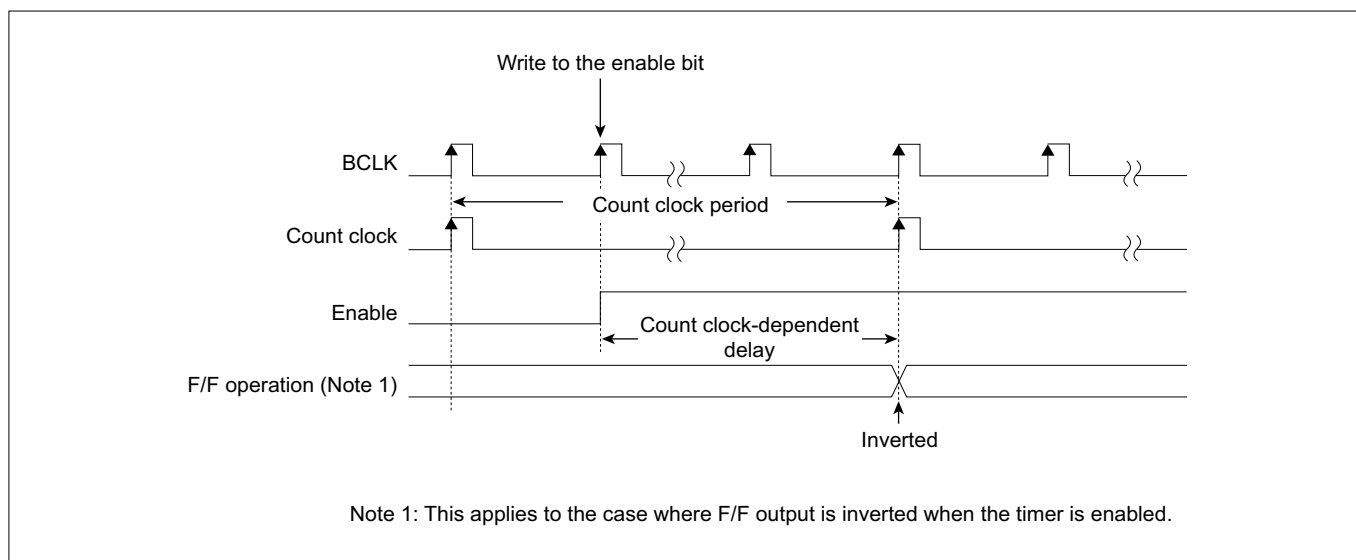
Thereafter, this operation is repeated each time an underflow occurs. To stop the counter, disable count by writing to the enable bit in software. The timing for reloading to counter is the cycle after underflow.

The F/F output waveform in continuous output mode is inverted(F/F output level changes from "L" to "H" or vice versa) at startup and upon underflow, generating a waveform of consecutive pulses until the timer stops counting.

Furthermore, it is possible to generate an interrupt request and a DMA transfer request (for only the TIO8 and TIO9) each time the counter underflows.

**<Count clock-dependent delay>**

- Because the timer operates synchronously with the count clock, up to one count clock-dependent delay is generated by the time when the timer actually starts operating after writing to the enable bit. In operation mode where the F/F output is inverted when the timer is enabled, there is also a count clock-dependent delay before the F/F output is inverted.

**Figure 10.4.2 Count Clock Dependent Delay**

## 10.4.3 TIO Related Register Map

Shown below is a TIO related register map.

TIO Related Register Map (1/2)

Address	+0 address	+1 address	See pages
	b0	b7 b8	b15
H'0080 0300	TIO0 Counter (TIO0CT)		10-105
H'0080 0302	(Use inhibited area)		
H'0080 0304	TIO0 Reload 1 Register (TIO0RL1)		10-107
H'0080 0306	TIO0 Reload 0/ Measure Register (TIO0RL0)		10-106
	(Use inhibited area)		
H'0080 0310	TIO1 Counter (TIO1CT)		10-105
H'0080 0312	(Use inhibited area)		
H'0080 0314	TIO1 Reload 1 Register (TIO1RL1)		10-107
H'0080 0316	TIO1 Reload 0/ Measure Register (TIO1RL0)		10-106
H'0080 0318	(Use inhibited area)		
H'0080 031A	TIO0–3 Control Register 0 (TIO03CR0)		10-98
H'0080 031C	(Use inhibited area)	TIO0–3 Control Register 1 (TIO03CR1)	10-99
	(Use inhibited area)		
H'0080 0320	TIO2 Counter (TIO2CT)		10-105
H'0080 0322	(Use inhibited area)		
H'0080 0324	TIO2 Reload 1 Register (TIO2RL1)		10-107
H'0080 0326	TIO2 Reload 0/ Measure Register (TIO2RL0)		10-106
	(Use inhibited area)		
H'0080 0330	TIO3 Counter (TIO3CT)		10-105
H'0080 0332	(Use inhibited area)		
H'0080 0334	TIO3 Reload 1 Register (TIO3RL1)		10-107
H'0080 0336	TIO3 Reload 0/ Measure Register (TIO3RL0)		10-106
	(Use inhibited area)		
H'0080 0340	TIO4 Counter (TIO4CT)		10-105
H'0080 0342	(Use inhibited area)		
H'0080 0344	TIO4 Reload 1 Register (TIO4RL1)		10-107
H'0080 0346	TIO4 Reload 0/ Measure Register (TIO4RL0)		10-106
H'0080 0348	(Use inhibited area)		
H'0080 034A	TIO4 Control Register (TIO4CR)	TIO5 Control Register (TIO5CR)	10-100 10-102
	(Use inhibited area)		

## TIO Related Register Map (2/2)

Address	+0 address		+1 address		See pages
	b0	b7	b8	b15	
H'0080 0350	TIO5 Counter (TIO5CT)				10-105
H'0080 0352	(Use inhibited area)				
H'0080 0354	TIO5 Reload 1 Register (TIO5RL1)				10-107
H'0080 0356	TIO5 Reload 0/ Measure Register (TIO5RL0)				10-106
	(Use inhibited area)				
H'0080 0360	TIO6 Counter (TIO6CT)				10-105
H'0080 0362	(Use inhibited area)				
H'0080 0364	TIO6 Reload 1 Register (TIO6RL1)				10-107
H'0080 0366	TIO6 Reload 0/ Measure Register (TIO6RL0)				10-106
H'0080 0368	(Use inhibited area)				
H'0080 036A	TIO6 Control Register (TIO6CR)		TIO7 Control Register (TIO7CR)		10-103 10-104
	(Use inhibited area)				
H'0080 0370	TIO7 Counter (TIO7CT)				10-105
H'0080 0372	(Use inhibited area)				
H'0080 0374	TIO7 Reload 1 Register (TIO7RL1)				10-107
H'0080 0376	TIO7 Reload 0/ Measure Register (TIO7RL0)				10-106
	(Use inhibited area)				
H'0080 0380	TIO8 Counter (TIO8CT)				10-105
H'0080 0382	(Use inhibited area)				
H'0080 0384	TIO8 Reload 1 Register (TIO8RL1)				10-107
H'0080 0386	TIO8 Reload 0/ Measure Register (TIO8RL0)				10-106
H'0080 0388	(Use inhibited area)				
H'0080 038A	TIO8 Control Register (TIO8CR)		TIO9 Control Register (TIO9CR)		10-104 10-105
	(Use inhibited area)				
H'0080 0390	TIO9 Counter (TIO9CT)				10-105
H'0080 0392	(Use inhibited area)				
H'0080 0394	TIO9 Reload 1 Register (TIO9RL1)				10-107
H'0080 0396	TIO9 Reload 0/ Measure Register (TIO9RL0)				10-106
	(Use inhibited area)				
H'0080 03BC	TIO0–9 Enable Protect Register (TIOPRO)				10-108
H'0080 03BE	TIO0–9 Count Enable Register (TIOCEN)				10-109



#### 10.4.4 TIO Control Registers

The TIO control registers are used to select operation modes of TIO0–9 (measure input, noise processing input, PWM output, single-shot output, delayed single-shot output or continuous output mode), as well as select the count enable and count clock sources.

Following TIO control registers are provided for each timer group.

- TIO0–3 Control Register 0 (TIO03CR0)
- TIO0–3 Control Register 1 (TIO03CR1)
- TIO4 Control Register (TIO4CR)
- TIO5 Control Register (TIO5CR)
- TIO6 Control Register (TIO6CR)
- TIO7 Control Register (TIO7CR)
- TIO8 Control Register (TIO8CR)
- TIO9 Control Register (TIO9CR)

TIO0–3 Control Register 0 (TIO03CR0)

&lt;Address: H'0080 031A&gt;

b0	1	2	3	4	5	6	7	8	9	10	11	12	13	14	b15
TIO3EEN	TIO3M			TIO2ENS	TIO2M			TIO1ENS	TIO1M			TIO0ENS	TIO0M		
0	0	0	0	0	0	0	0	0	0	0	0	0	0	0	0

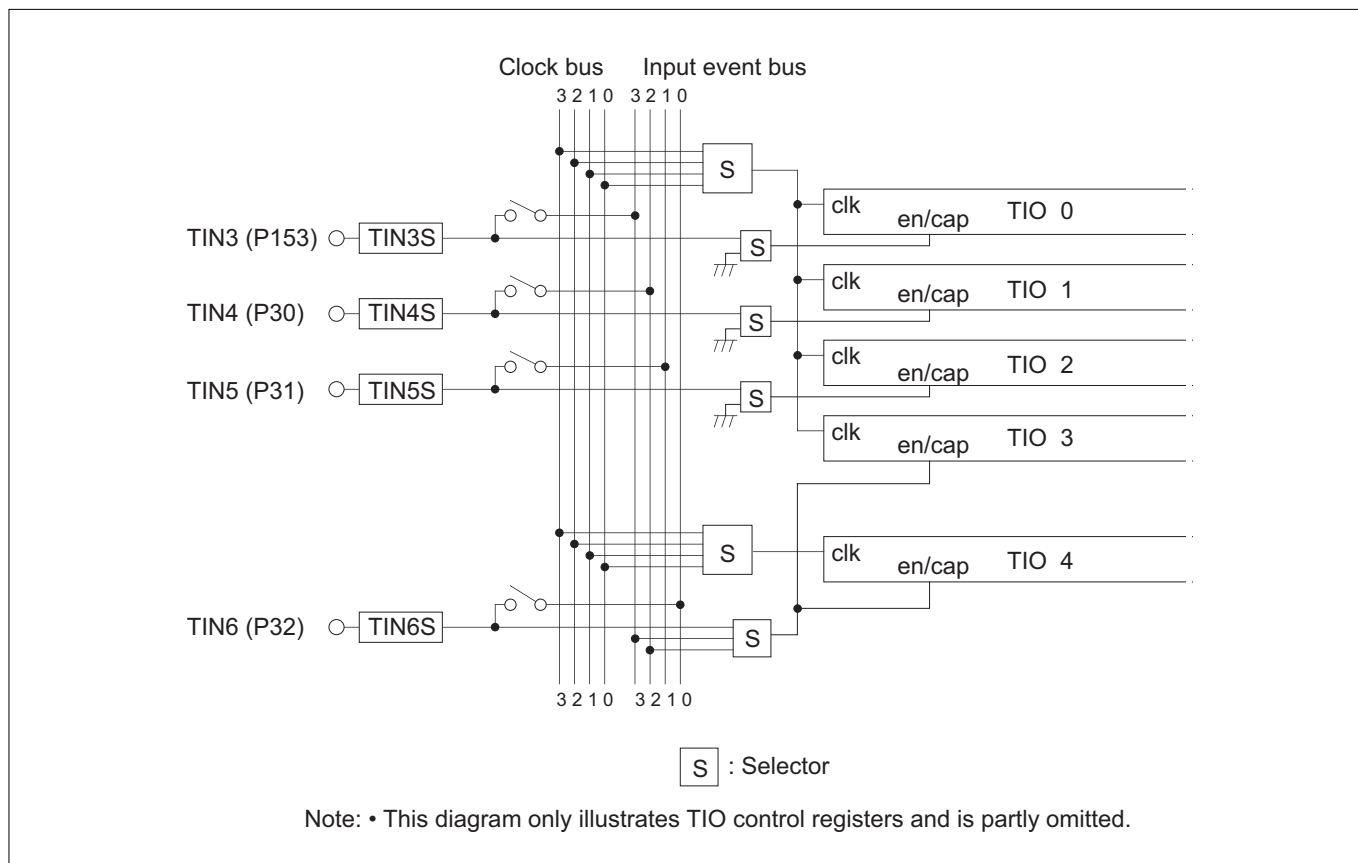
&lt;Upon exiting reset: H'0000&gt;

b	Bit Name	Function	R	W
0	TIO3EEN (Note 1) TIO3 external input enable bit	0: Disable external input 1: Enable external input	R	W
1–3	TIO3M TIO3 operation mode select bit	000: Single-shot output mode 001: Delayed single-shot output mode 010: Continuous output mode 011: PWM output mode 100: Measure clear input mode 101: Measure free-run input mode 110: Noise processing input mode 111: Noise processing input mode	R	W
4	TIO2ENS TIO2 enable/measure input source select bit	0: Do not use enable/measure input source 1: External input TIN5	R	W
5–7	TIO2M TIO2 operation mode select bit	000: Single-shot output mode 001: Delayed single-shot output mode 010: Continuous output mode 011: PWM output mode 100: Measure clear input mode 101: Measure free-run input mode 110: Noise processing input mode 111: Noise processing input mode	R	W
8	TIO1ENS TIO1 enable/measure input source select bit	0: Do not use enable/measure input source 1: External input TIN4	R	W
9–11	TIO1M TIO1 operation mode select bit	000: Single-shot output mode 001: Delayed single-shot output mode 010: Continuous output mode 011: PWM output mode 100: Measure clear input mode 101: Measure free-run input mode 110: Noise processing input mode 111: Noise processing input mode	R	W
12	TIO0ENS TIO0 enable/measure input source select bit	0: Do not use enable/measure input source 1: External input TIN3	R	W
13–15	TIO0M TIO0 operation mode select bit	000: Single-shot output mode 001: Delayed single-shot output mode 010: Continuous output mode 011: PWM output mode 100: Measure clear input mode 101: Measure free-run input mode 110: Noise processing input mode 111: Noise processing input mode	R	W

Note 1: During measure free-run/clear input mode, even if this bit is set to "0" (external input disabled), when a capture signal is entered from an external device, the counter value at that point in time is written into the measure register. In measure clear input mode, however, if this bit = "0" (external input disabled), the counter value is not initialized (H'FFFF) upon capture and, therefore, this bit should be set to "1" (external input enabled) when using measure clear input mode.

Notes: • This register must always be accessed in halfwords.

- Operation mode can only be set or changed while the counter is inactive.
- To select TIO3 enable/measure input sources, use the TIO4 Control Register TIO34ENS (TIO3, TIO4 enable/measure input source select) bits.



**Figure 10.4.3 Outline Diagram of TIO0-4 Clock and Enable Inputs**

TIO0-3 Control Register 1 (TIO03CR1)

<Address: H'0080 031D>

b8	9	10	11	12	13	14	b15
0	0	0	0	0	0	TIO03CKS	0

<Upon exiting reset: H'00>

b	Bit Name	Function	R	W
8-13	No function assigned. Fix to "0."		0	0
14, 15	TIO03CKS TIO0-3 clock source select bit	00: Clock bus 0 01: Clock bus 1 10: Clock bus 2 11: Clock bus 3	R	W

TIO4 Control Register (TIO4CR)

&lt;Address: H'0080 034A&gt;

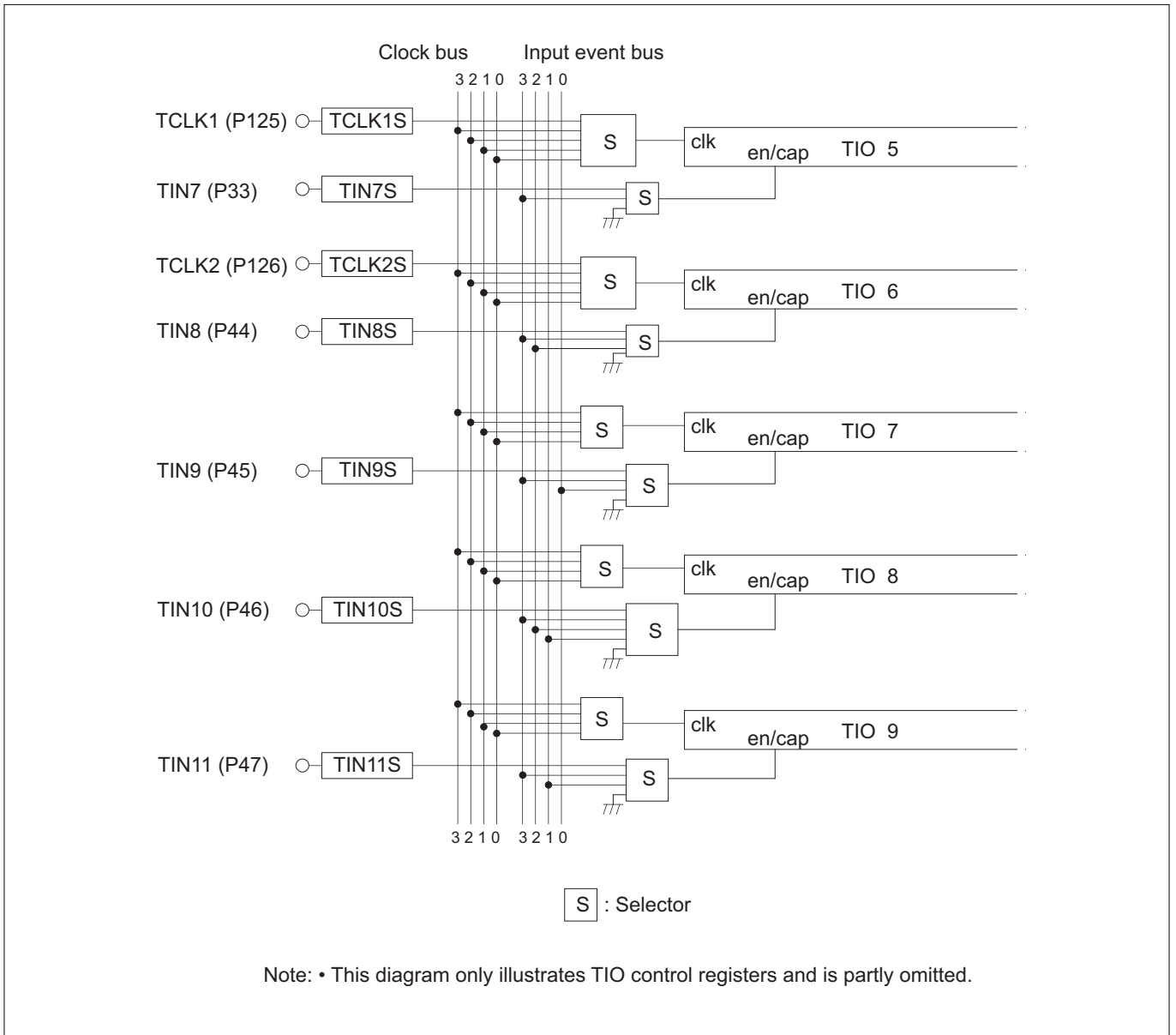
b0	1	2	3	4	5	6	b7
TIO4CKS		TIO4EEN	TIO34ENS		TIO4M		
0	0	0	0	0	0	0	0

&lt;Upon exiting reset: H'00&gt;

b	Bit Name	Function	R	W
0, 1	TIO4CKS TIO4 clock source select bit	00: Clock bus 0 01: Clock bus 1 10: Clock bus 2 11: Clock bus 3	R	W
2	TIO4EEN (Note 1) TIO4 external input enable bit	0: Disable external input 1: Enable external input	R	W
3, 4	TIO34ENS TIO3,4 enable/measure input source select bit	00: External input TIN6 01: External input TIN6 10: Input event bus 2 11: Input event bus 3	R	W
5–7	TIO4M TIO4 operation mode select bit	000: Single-shot output mode 001: Delayed single-shot output mode 010: Continuous output mode 011: PWM output mode 100: Measure clear input mode 101: Measure free-run input mode 110: Noise processing input mode 111: Noise processing input mode	R	W

Note 1: During measure free-run/clear input mode, even if this bit is set to "0" (external input disabled), when a capture signal is entered from an external device, the counter value at that point in time is written into the measure register. In measure clear input mode, however, if this bit = "0" (external input disabled), the counter value is not initialized (H'FFFF) upon capture and, therefore, this bit should be set to "1" (external input enabled) when using measure clear input mode.

Note: • Operation mode can only be set or changed while the counter is inactive.



**Figure 10.4.4 Outline Diagram of TIO5-9 Clock and Enable Inputs**

TIO5 Control Register (TIO5CR)

&lt;Address: H'0080 034B&gt;

b8	9	10	11	12	13	14	b15
TIO5CKS			TIO5ENS		TIO5M		
0	0	0	0	0	0	0	0

&lt;Upon exiting reset: H'00&gt;

b	Bit Name	Function	R	W
8–10	TIO5CKS TIO5 clock source select bit	000: External input TCLK1 001: External input TCLK1 010: External input TCLK1 011: External input TCLK1 100: Clock bus 0 101: Clock bus 1 110: Clock bus 2 111: Clock bus 3	R	W
11, 12	TIO5ENS TIO5 enable/measure input source select bit	00: Do not use enable/measure input source 01: Do not use enable/measure input source 10: External input TIN7 11: Input event bus 3	R	W
13–15	TIO5M TIO5 operation mode select bit	000: Single-shot output mode 001: Delayed single-shot output mode 010: Continuous output mode 011: PWM output mode 100: Measure clear input mode 101: Measure free-run input mode 110: Noise processing input mode 111: Noise processing input mode	R	W

Note: • Operation mode can only be set or changed while the counter is inactive.

TIO6 Control Register (TIO6CR)

&lt;Address: H'0080 036A&gt;

b0	1	2	3	4	5	6	b7
TIO6CKS			TIO6ENS		TIO6M		
0	0	0	0	0	0	0	0

&lt;Upon exiting reset: H'00&gt;

b	Bit Name	Function	R	W
0-2	TIO6CKS TIO6 clock source select bit	000: External input TCLK2 001: External input TCLK2 010: External input TCLK2 011: External input TCLK2 100: Clock bus 0 101: Clock bus 1 110: Clock bus 2 111: Clock bus 3	R	W
3, 4	TIO6ENS TIO6 enable/measure input source select bit	00: Do not use enable/measure input source 01: External input TIN8 10: Input event bus 2 11: Input event bus 3	R	W
5-7	TIO6M TIO6 operation mode select bit	000: Single-shot output mode 001: Delayed single-shot output mode 010: Continuous output mode 011: PWM output mode 100: Measure clear input mode 101: Measure free-run input mode 110: Noise processing input mode 111: Noise processing input mode	R	W

Note: • Operation mode can only be set or changed while the counter is inactive.

## TIO7 Control Register (TIO7CR)

&lt;Address: H'0080 036B&gt;

b8	9	10	11	12	13	14	b15
0	TIO7CKS		TIO7ENS		0	TIO7M	
0	0	0	0	0	0	0	0

&lt;Upon exiting reset: H'00&gt;

b	Bit Name	Function	R	W
8	No function assigned. Fix to "0."		0	0
9, 10	TIO7CKS TIO7 clock source select bit	00: Clock bus 0 01: Clock bus 1 10: Clock bus 2 11: Clock bus 3	R	W
11, 12	TIO7ENS TIO7 enable/measure input source select bit	00: Do not use enable/measure input source 01: External input TIN9 10: Input event bus 0 11: Input event bus 3	R	W
13–15	TIO7M TIO7 operation mode select bit	000: Single-shot output mode 001: Delayed single-shot output mode 010: Continuous output mode 011: PWM output mode 100: Measure clear input mode 101: Measure free-run input mode 110: Noise processing input mode 111: Noise processing input mode	R	W

Note: • Operation mode can only be set or changed while the counter is inactive.

## TIO8 Control Register (TIO8CR)

&lt;Address: H'0080 038A&gt;

b0	1	2	3	4	5	6	b7
TIO8CKS		TIO8ENS			TIO8M		
0	0	0	0	0	0	0	0

&lt;Upon exiting reset: H'00&gt;

b	Bit Name	Function	R	W
0, 1	TIO8CKS TIO8 clock source select bit	100: Clock bus 0 101: Clock bus 1 110: Clock bus 2 111: Clock bus 3	R	W
2–4	TIO8ENS TIO8 enable/measure input source select bit	000: Do not use enable/measure input source 001: Do not use enable/measure input source 010: Do not use enable/measure input source 011: Do not use enable/measure input source 100: External input TIN10 101: Input event bus 1 110: Input event bus 2 111: Input event bus 3	R	W
5–7	TIO8M TIO8 operation mode select bit	000: Single-shot output mode 001: Delayed single-shot output mode 010: Continuous output mode 011: PWM output mode 100: Measure clear input mode 101: Measure free-run input mode 110: Noise processing input mode 111: Noise processing input mode	R	W

Note: • Operation mode can only be set or changed while the counter is inactive.



TIO9 Control Register (TIO9CR)

<Address: H'0080 038B>

b8	9	10	11	12	13	14	b15
0	TIO9CKS		TIO9ENS		TIO9M		
0	0	0	0	0	0	0	0

<Upon exiting reset: H'00>

b	Bit Name	Function	R	W
8	No function assigned. Fix to "0."		0	0
9, 10	TIO9CKS TIO9 clock source select bit	00: Clock bus 0 01: Clock bus 1 10: Clock bus 2 11: Clock bus 3	R	W
11, 12	TIO9ENS TIO9 enable/measure input source select bit	00: Do not use enable/measure input source 01: External input TIN11 10: Input event bus 1 11: Input event bus 3	R	W
13–15	TIO9M TIO9 operation mode select bit	000: Single-shot output mode 001: Delayed single-shot output mode 010: Continuous output mode 011: PWM output mode 100: Measure clear input mode 101: Measure free-run input mode 110: Noise processing input mode 111: Noise processing input mode	R	W

Note: • Operation mode can only be set or changed while the counter is inactive.

#### 10.4.5 TIO Counters (TIO0CT–TIO9CT)

TIO0 Counter (TIO0CT)	<Address: H'0080 0300>
TIO1 Counter (TIO1CT)	<Address: H'0080 0310>
TIO2 Counter (TIO2CT)	<Address: H'0080 0320>
TIO3 Counter (TIO3CT)	<Address: H'0080 0330>
TIO4 Counter (TIO4CT)	<Address: H'0080 0340>
TIO5 Counter (TIO5CT)	<Address: H'0080 0350>
TIO6 Counter (TIO6CT)	<Address: H'0080 0360>
TIO7 Counter (TIO7CT)	<Address: H'0080 0370>
TIO8 Counter (TIO8CT)	<Address: H'0080 0380>
TIO9 Counter (TIO9CT)	<Address: H'0080 0390>

b0	1	2	3	4	5	6	7	8	9	10	11	12	13	14	b15
TIO0CT–TIO9CT															
?	?	?	?	?	?	?	?	?	?	?	?	?	?	?	?

<Upon exiting reset: Undefined>

b	Bit Name	Function	R	W
0–15	TIO0CT–TIO9CT	16-bit counter value	R	(Note 1)

Note 1: Protected against write during PWM output mode.

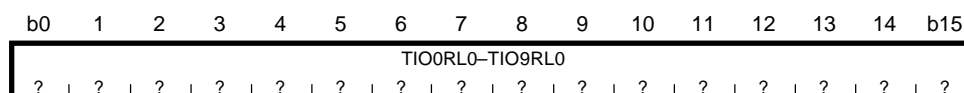
Note: • These registers must always be accessed in halfwords.

The TIO counters are a 16-bit down-counter. After the timer is enabled (by writing to the enable bit in software or by external input), the counter starts counting synchronously with the count clock.

These counters are protected against write during PWM output mode.

#### 10.4.6 TIO Reload 0/ Measure Registers (TIO0RL0–TIO9RL0)

TIO0 Reload 0/ Measure Register (TIO0RL0)	<Address: H'0080 0306>
TIO1 Reload 0/ Measure Register (TIO1RL0)	<Address: H'0080 0316>
TIO2 Reload 0/ Measure Register (TIO2RL0)	<Address: H'0080 0326>
TIO3 Reload 0/ Measure Register (TIO3RL0)	<Address: H'0080 0336>
TIO4 Reload 0/ Measure Register (TIO4RL0)	<Address: H'0080 0346>
TIO5 Reload 0/ Measure Register (TIO5RL0)	<Address: H'0080 0356>
TIO6 Reload 0/ Measure Register (TIO6RL0)	<Address: H'0080 0366>
TIO7 Reload 0/ Measure Register (TIO7RL0)	<Address: H'0080 0376>
TIO8 Reload 0/ Measure Register (TIO8RL0)	<Address: H'0080 0386>
TIO9 Reload 0/ Measure Register (TIO9RL0)	<Address: H'0080 0396>



<Upon exiting reset: Undefined>

b	Bit Name	Function	R	W
0–15	TIO0RL0–TIO9RL0	16-bit reload register value	R	W (Note 1)

Note 1: These registers are protected against write during measure input mode.

Note: • These registers must always be accessed in halfwords.

The TIO Reload 0/ Measure Registers serve dual purposes as a register for reloading data into the TIO Count Registers (TIO0CT–TIO9CT) and as a measure register during measure input mode. These registers are protected against write during measure input mode.

The content of "the reload 0 register -1" is reloaded into the counter synchronously with the count clock at the following timing:

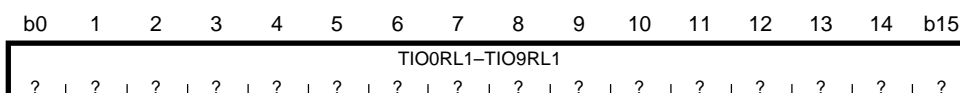
- At the next cycle when after the counter started counting in noise processing input mode, the input signal is inverted and a valid-level signal is entered again before the counter underflows
- At the next cycle when the counter is enabled in single-shot output mode
- At the next cycle when the counter underflowed in delayed single-shot output or continuous output mode
- At the next cycle when the counter is enabled in PWM output mode and at the next cycle when the counter value set by the reload 1 register underflowed

Simply because data is written to the reload 0 register does not mean that the data is loaded into the counter. The counter is loaded with data in only the above cases.

If the register is used as a measure register, the counter value is latched into that measure register by event input.

#### 10.4.7 TIO Reload 1 Registers (TIO0RL1–TIO9RL1)

TIO0 Reload 1 Register (TIO0RL1)	<Address: H'0080 0304>
TIO1 Reload 1 Register (TIO1RL1)	<Address: H'0080 0314>
TIO2 Reload 1 Register (TIO2RL1)	<Address: H'0080 0324>
TIO3 Reload 1 Register (TIO3RL1)	<Address: H'0080 0334>
TIO4 Reload 1 Register (TIO4RL1)	<Address: H'0080 0344>
TIO5 Reload 1 Register (TIO5RL1)	<Address: H'0080 0354>
TIO6 Reload 1 Register (TIO6RL1)	<Address: H'0080 0364>
TIO7 Reload 1 Register (TIO7RL1)	<Address: H'0080 0374>
TIO8 Reload 1 Register (TIO8RL1)	<Address: H'0080 0384>
TIO9 Reload 1 Register (TIO9RL1)	<Address: H'0080 0394>



<Upon exiting reset: Undefined>

b	Bit Name	Function	R	W
0–15	TIO0RL1–TIO9RL1	16-bit reload register value	R	W

Note: • These registers must always be accessed in halfwords.

The TIO Reload 1 Registers are used to reload data into the TIO Count Registers (TIO0CT–TIO9CT).

The content of "the reload 1 register -1" is reloaded into the counter counting synchronously with the count clock at the following timing:

- At the next cycle when the count value set by the reload 0 register underflowed in PWM output mode

Simply because data is written to the reload 1 register does not mean that the data is loaded into the counter. The counter is loaded with data in only the above cases.

#### 10.4.8 TIO Enable Control Registers

TIO0–9 Enable Protect Register (TIOPRO)

<Address: H'0080 03BC>

b0	1	2	3	4	5	6	7	8	9	10	11	12	13	14	b15
0	0	0	0	0	0	TIO9 PRO 0	TIO8 PRO 0	TIO7 PRO 0	TIO6 PRO 0	TIO5 PRO 0	TIO4 PRO 0	TIO3 PRO 0	TIO2 PRO 0	TIO1 PRO 0	TIO0 PRO 0

<Upon exiting reset: H'0000>

b	Bit Name	Function	R	W
0–5	No function assigned. Fix to "0."		0	0
6	TIO9PRO (TIO9 enable protect bit)	0: Enable rewrite	R	W
7	TIO8PRO (TIO8 enable protect bit)	1: Disable rewrite		
8	TIO7PRO (TIO7 enable protect bit)			
9	TIO6PRO (TIO6 enable protect bit)			
10	TIO5PRO (TIO5 enable protect bit)			
11	TIO4PRO (TIO4 enable protect bit)			
12	TIO3PRO (TIO3 enable protect bit)			
13	TIO2PRO (TIO2 enable protect bit)			
14	TIO1PRO (TIO1 enable protect bit)			
15	TIO0PRO (TIO0 enable protect bit)			

Note: • This register must always be accessed in halfwords.

The TIO0–9 Enable Protect Register controls rewriting of the TIO count enable bit described in the next page by enabling or disabling it.

TIO0–9 Count Enable Register (TIOECEN)

<Address: H'0080 03BE>

b0	1	2	3	4	5	6	7	8	9	10	11	12	13	14	b15
0	0	0	0	0	0	TIO9 CEN 0	TIO8 CEN 0	TIO7 CEN 0	TIO6 CEN 0	TIO5 CEN 0	TIO4 CEN 0	TIO3 CEN 0	TIO2 CEN 0	TIO1 CEN 0	TIO0 CEN 0

<Upon exiting reset: H'0000>

b	Bit Name	Function	R	W
0–5	No function assigned. Fix to "0."		0	0
6	TIO9CEN (TIO9 count enable bit)	0: Stop count	R	W
7	TIO8CEN (TIO8 count enable bit)	1: Enable count		
8	TIO7CEN (TIO7 count enable bit)			
9	TIO6CEN (TIO6 count enable bit)			
10	TIO5CEN (TIO5 count enable bit)			
11	TIO4CEN (TIO4 count enable bit)			
12	TIO3CEN (TIO3 count enable bit)			
13	TIO2CEN (TIO2 count enable bit)			
14	TIO1CEN (TIO1 count enable bit)			
15	TIO0CEN (TIO0 count enable bit)			

Note: • This register must always be accessed in halfwords

The TIO0–9 Count Enable Register controls operation of the TIO counters. To enable any TIO counter in software, enable its corresponding enable protect bit for write and set the count enable bit by writing "1." To stop any TIO counter, enable its corresponding enable protect bit for write and reset the count enable bit by writing "0."

In all but continuous output mode, when the counter stops due to occurrence of an underflow, the count enable bit is automatically reset to "0." Therefore, the TIO0–9 Count Enable Register when accessed for read serves as a status register indicating whether the counter is operating or idle.

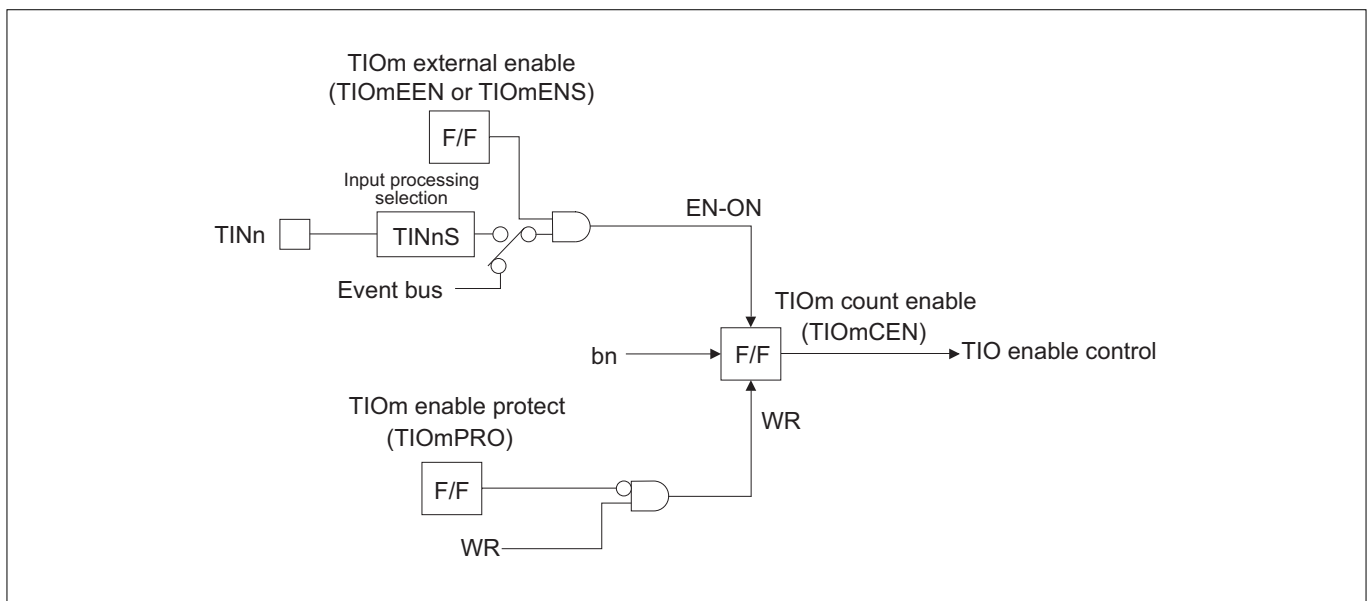


Figure 10.4.5 Configuration of the TIO Enable Circuit

#### 10.4.9 Operation in TIO Measure Free-Run/Clear Input Modes

##### (1) Outline of TIO measure free-run/clear input modes

In measure free-run/clear input modes, the timer is used to measure a duration of time from when the counter starts counting until when an external capture signal is entered. It is possible to generate an interrupt request upon underflow of the counter or execution of measurement operation and a DMA transfer request (for only the TIO8 and TIO9) upon underflow of the counter.

After the timer is enabled (by writing to the enable bit in software), the counter starts counting down synchronously with the count clock. When a capture signal is entered from an external device, the counter value at that point in time is written into a register called the “measure register.”

In measure clear input mode, the counter value is initialized to H'FFFF upon capture, from which the counter starts counting down again. The counter returns to H'FFFF upon underflow, from which it starts counting down. In measure free-run input mode, the counter continues counting down even after capture and upon underflow, recycles to H'FFFF, from which it starts counting down again.

To stop the counter, disable count by writing to the enable bit in software.

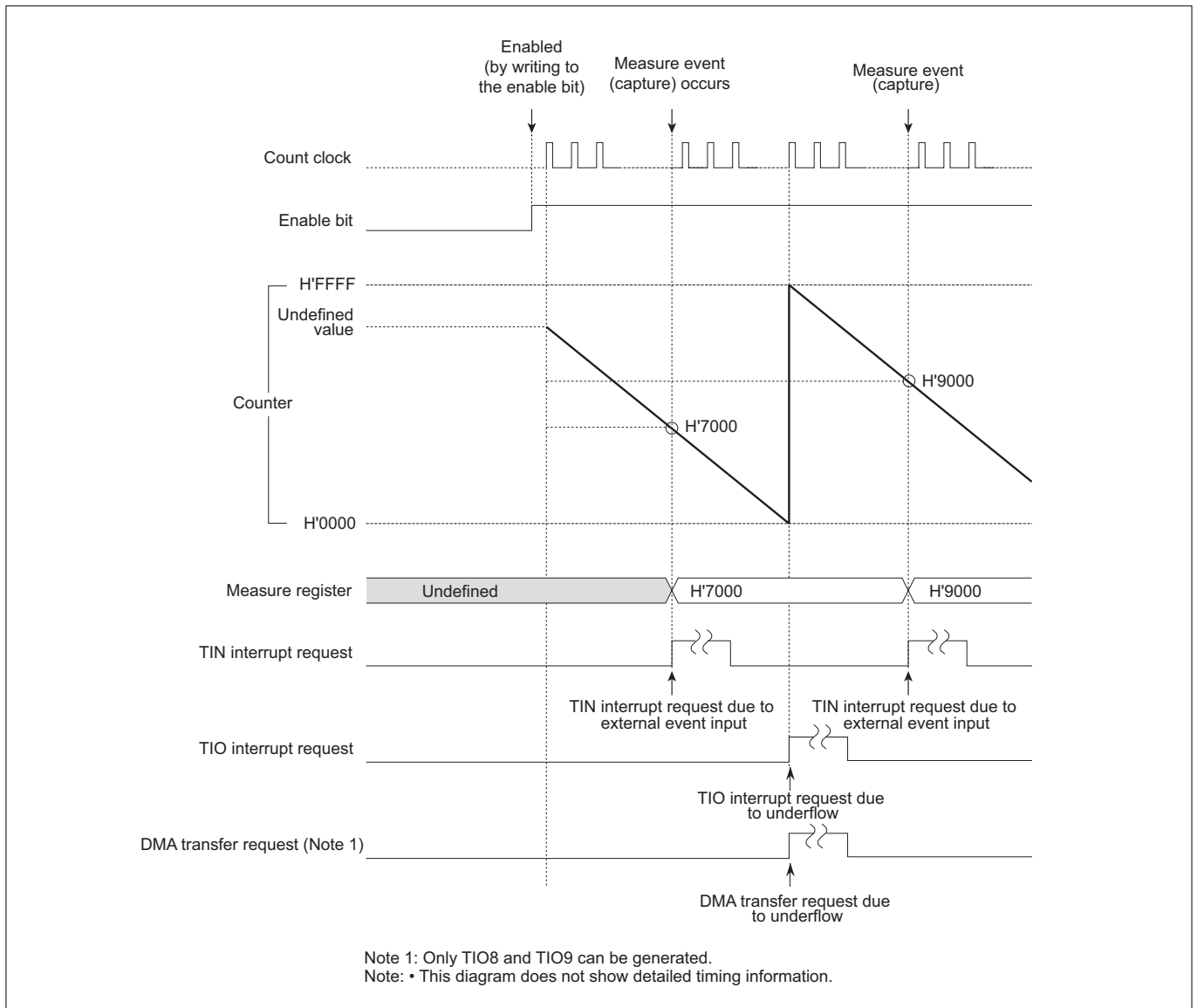


Figure 10.4.6 Typical Operation in Measure Free-Run Input Mode

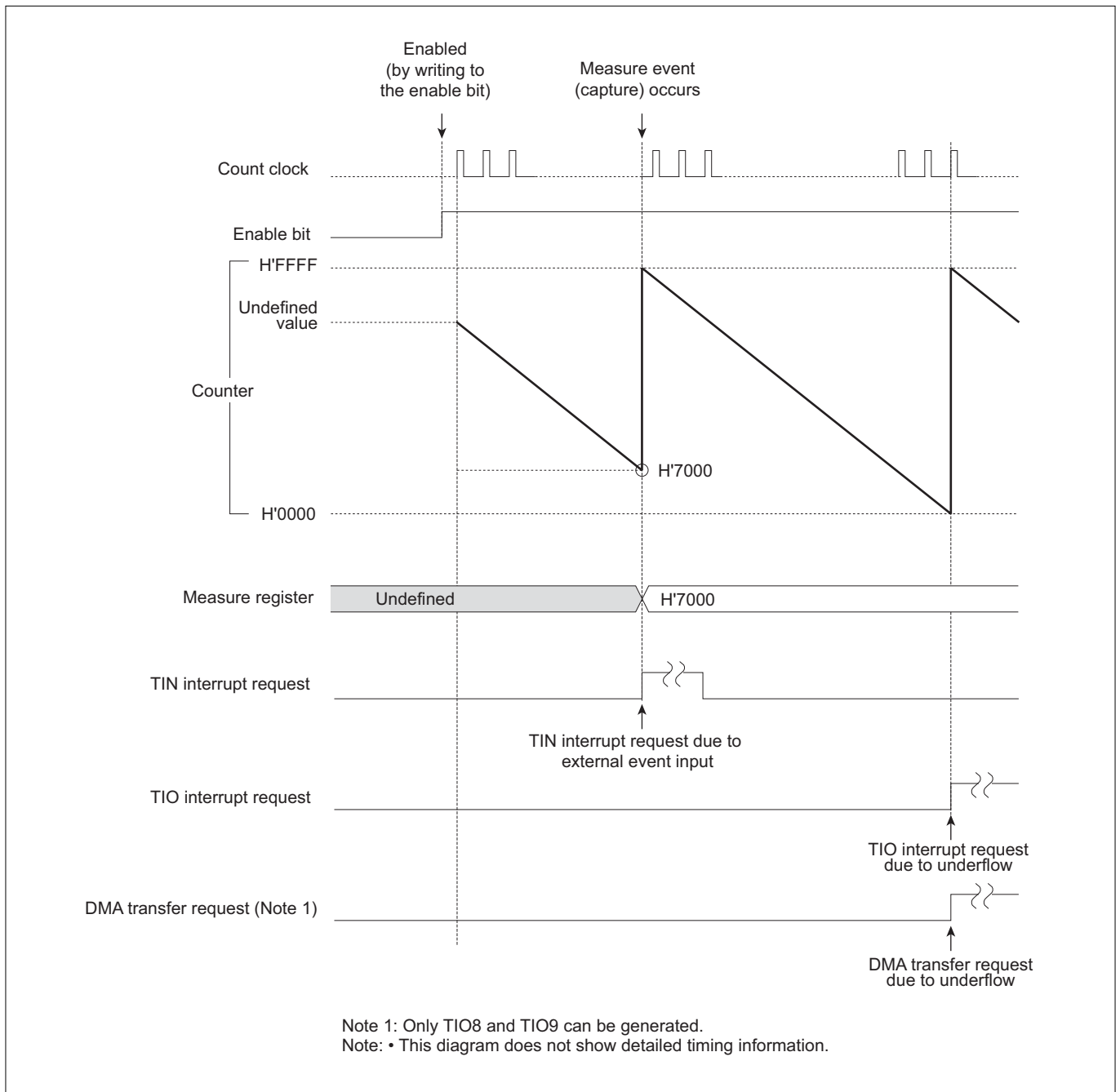


Figure 10.4.7 Typical Operation in Measure Clear Input Mode

## (2) Notes on using TIO measure free-run/ clear input modes

The following describes precautions to be observed when using TIO measure free-run/ clear input modes.

- If measure event input and write to the counter occur in the same clock period, the write value is set in the counter while at the same time latched into the measure register.

#### 10.4.10 Operation in TIO Noise Processing Input Mode

In noise processing input mode, the timer is used to detect that the input signal remained in the same state for over a predetermined time.

In noise processing input mode, a "H" or "L" level on external input activates the counter and if the input signal remains in the same state for over a predetermined time before the counter underflows, the counter generates an interrupt request before stopping. If the valid-level signal being applied turns to an invalid level before the counter underflows, the counter temporarily stops counting and at the next cycle after a valid-level signal is entered again, the counter is reloaded with the value that "reload register -1" and restarts counting. The effective count width is "reload 0 register set value + 1."

The timer stops at the same time the counter underflows or count is disabled by writing to the enable bit. Furthermore, it is possible to generate an interrupt request and a DMA transfer request (for only the TIO8 and TIO9) upon underflow of the counter.

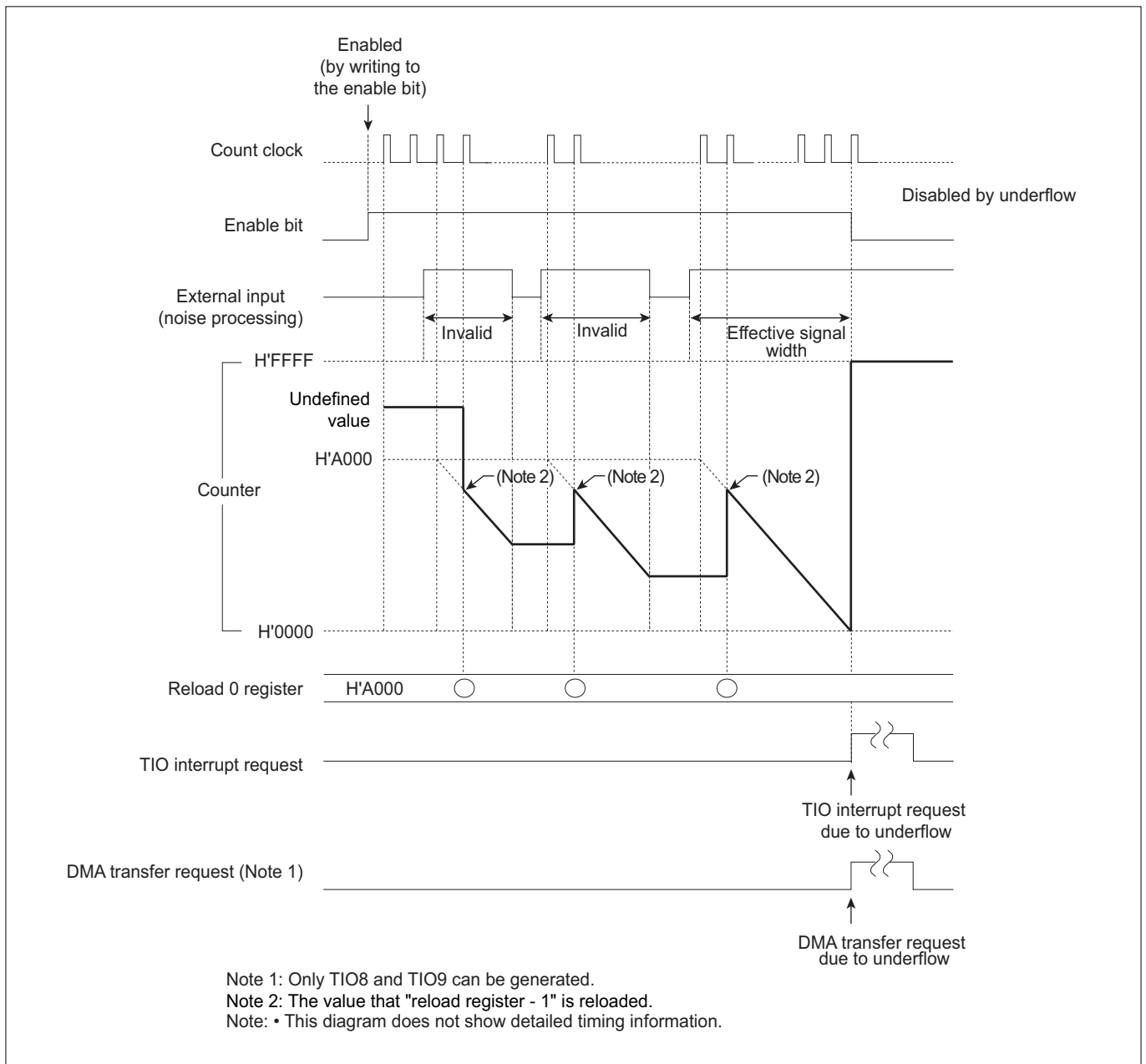


Figure 10.4.8 Typical Operation in Noise Processing Input Mode



#### 10.4.11 Operation in TIO PWM Output Mode

##### (1) Outline of TIO PWM output mode

In PWM output mode, the timer uses two reload registers to generate a waveform with a given duty cycle.

When the timer is enabled "by writing to the enable bit in software or by external input" after setting the initial values in the reload 0 and reload 1 registers, the counter is loaded with the value that "the reload 0 register - 1" and starts counting down synchronously with the count clock at the next cycle. At the cycle after the first time the counter underflows, it is loaded with the value that "the reload 1 register - 1" and continues counting. Thereafter, the counter is loaded with the reload 0 and reload 1 register values alternately each time an underflow occurs. The "reload 0 register set value + 1" and "reload 1 register set value + 1" respectively are effective as count values. The timer stops at the same time count is disabled by writing to the enable bit "and not in synchronism with PWM output period."

The F/F output waveform in PWM output mode is inverted "F/F output level changes from "L" to "H" or vice versa" when the counter starts counting and each time it underflows.

Furthermore, it is possible to generate an interrupt request at even-numbered occurrences of underflow after the counter is enabled and a DMA transfer request "for only the TIO8 and TIO9" every time the counter underflows.

Note that TIO's PWM output mode does not have the count correction function.

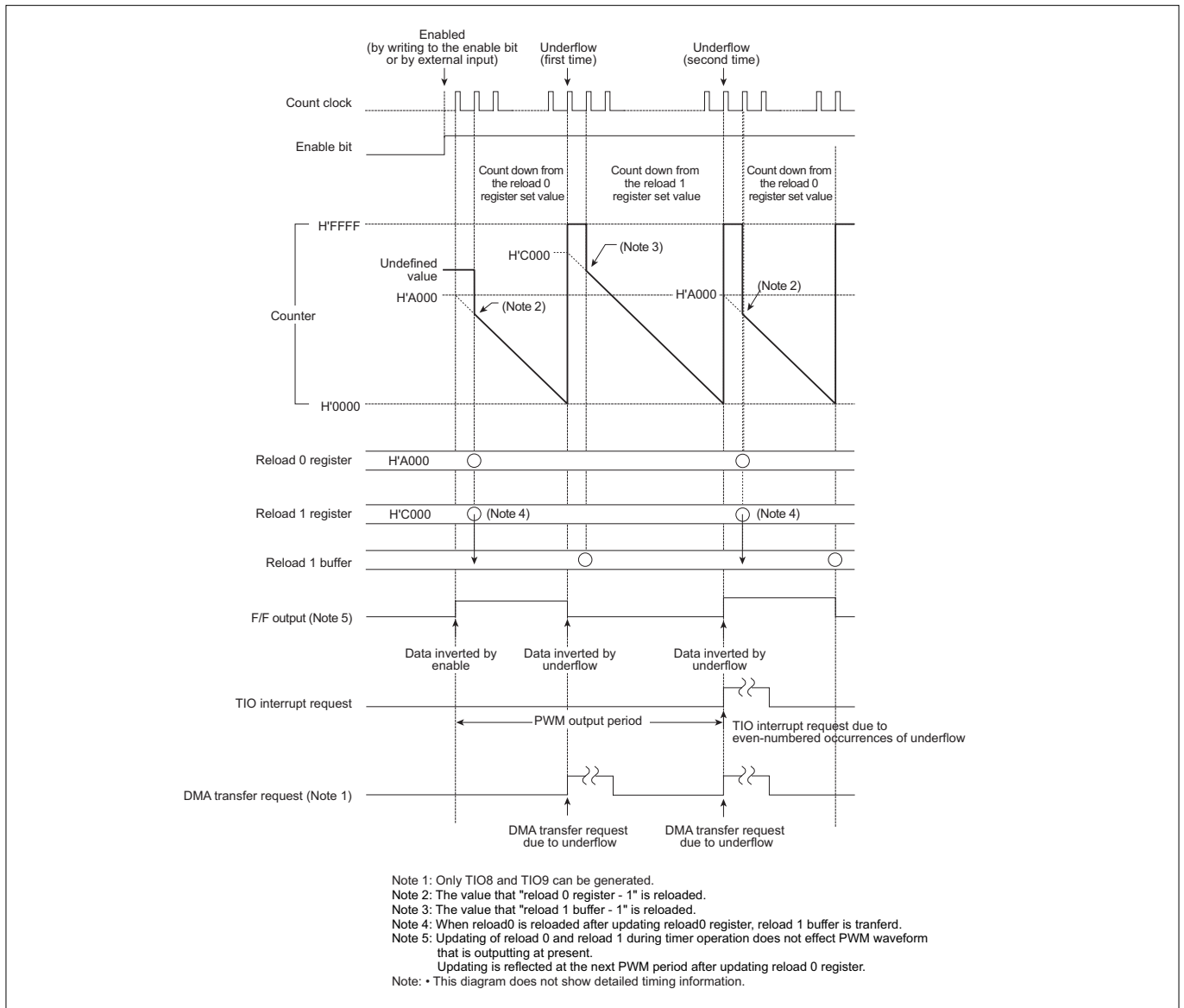
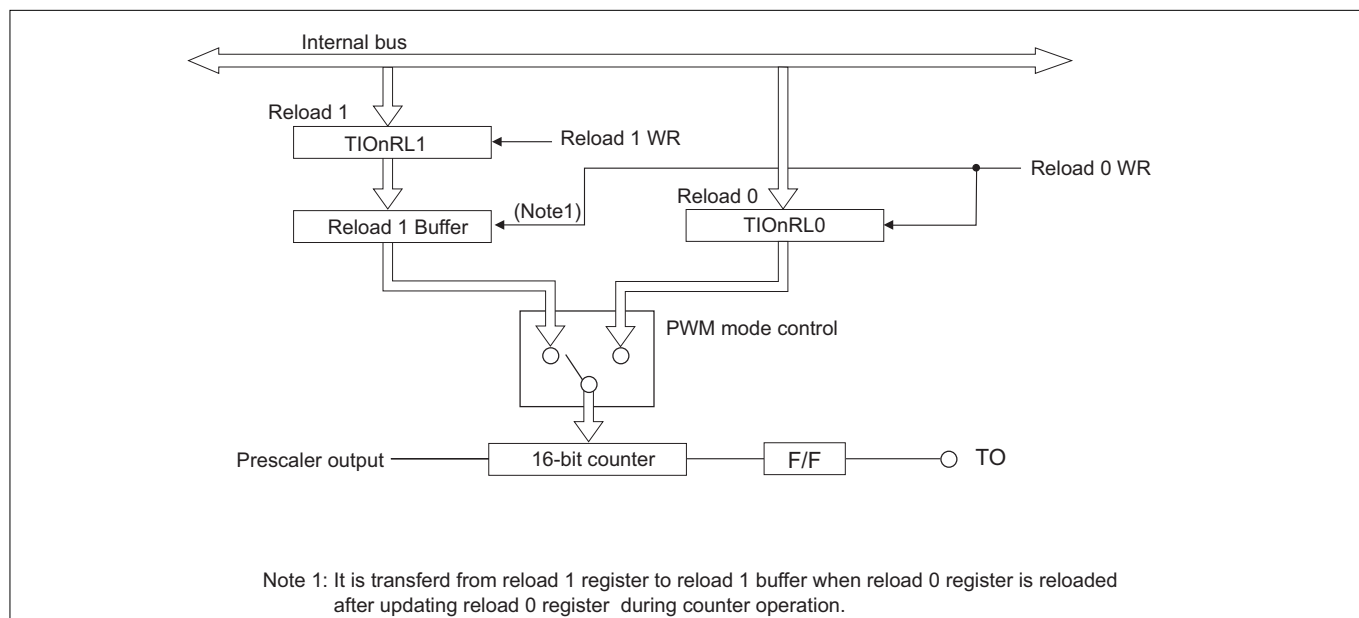


Figure 10.4.9 Typical Operation in PWM Output Mode

**(2) Reload register updates in TIO PWM output mode**

In PWM output mode, when the timer remains idle, the reload 0 and reload 1 registers are updated at the same time data are written to the respective registers. But when the timer is operating, the reload 1 register is updated by updating the reload 0 register. However, if the reload 0 and reload 1 registers are accessed for read, the read values are always the data that have been written to the respective registers.



**Figure 10.4.10 PWM Circuit Diagram**

To rewrite the reload 0 and reload 1 registers while the timer is operating, rewrite the reload 1 register first and then the reload 0 register. That way, the reload 0 and reload 1 registers both are updated synchronously with PWM period, from which the timer starts operating. This operation can normally be performed collectively by accessing 32-bit addresses beginning with the reload 1 register address wordwise. (Data are automatically written to the reload 1 and then the reload 0 registers in succession.)

If the reload 0 and reload 1 registers are accessed for read, the read values are always the data that have been written to the respective registers, and not the reload values being actually used.

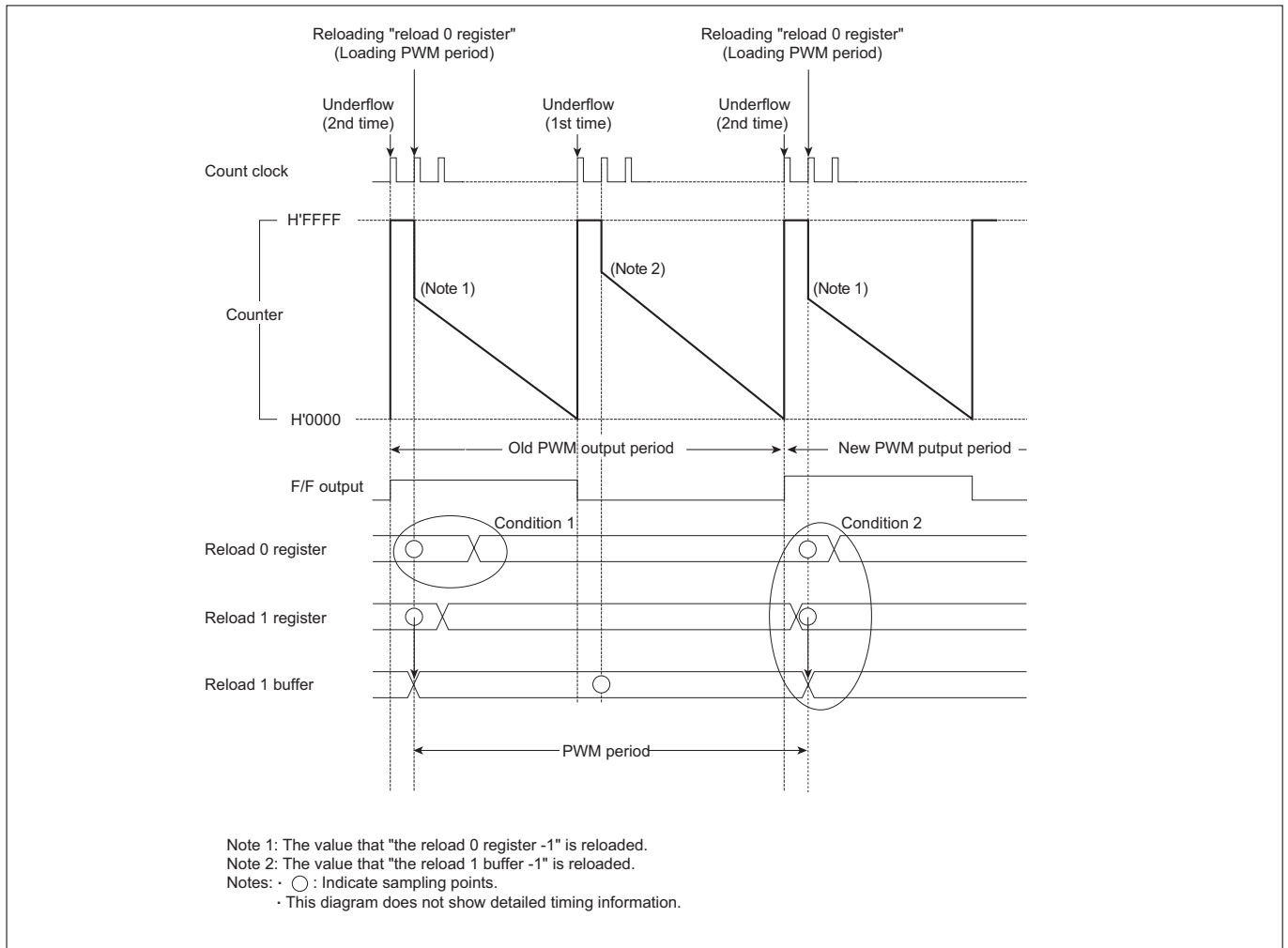
When altering PWM period by rewriting the reload registers, if the PWM period terminates before the CPU finishes writing to reload 0, the PWM period is not altered in the current session and the data written to the register is reflected in the next period.

When altering PWM period by rewriting the reload registers, if the PWM period terminates before the CPU finishes writing to reload 0, the PWM period is not altered in the current session and the data written to the register is reflected in the next period.

When operating in the PWM output mode, writing the reload 0 register and reload 1 register more than twice within the PWM period and meet the following conditions at the same time, the PWM waveform is output with the value that the last time written reload 0 register and finally written reload 1 register.

Condition 1: Start writing reload 0 register after latching the reload 0 register PWM period of the old PWM output period.

Condition 2: Rewrite reload 1 register before latching PWM period of the new PWM output period and start writing reload 0 register after latching PWM period.



**Figure 10.4.11 Update timing of PWM period**

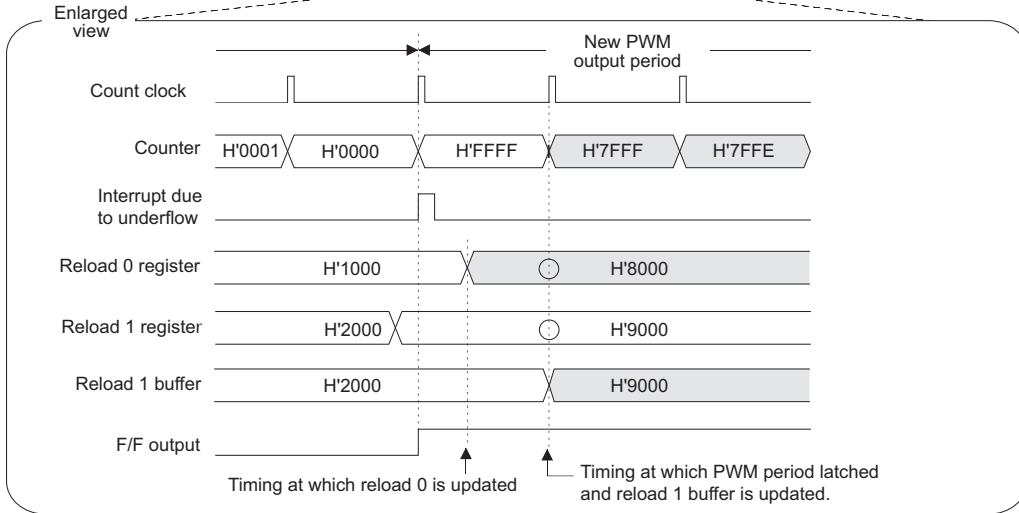
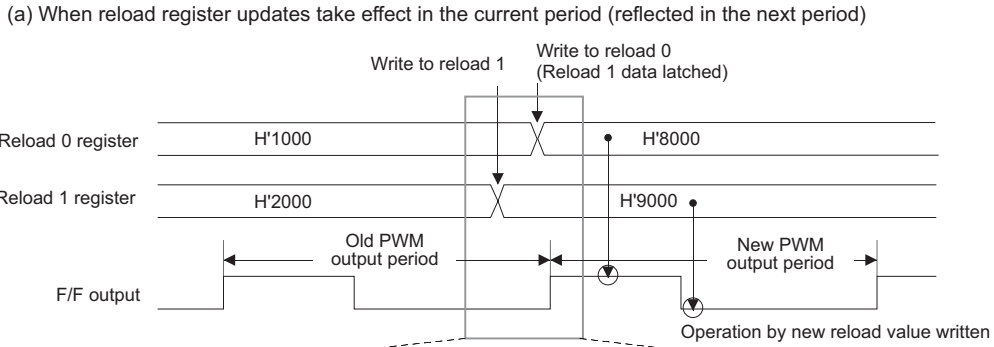
To update PWM period correctly, take either one of the following measures.

- Identify the completion timing of PWM period by reading counter value at writing reload 1 register and reload 0 register, and then start writing reload 1 register and reload 0 register without crossing PWM period.
- When writing to reload 1 register and reload 0 register by using interruption, set the prescaler value of counter as small as possible. By doing this, write to reload 1 register and reload 0 register later than the counter to be H'FFFF in the PWM period.
- Writing reload 1 register and reload 0 register is performed under the period, less than one time per PWM period. (Extend the reload register's rewrite period against PWM period.)

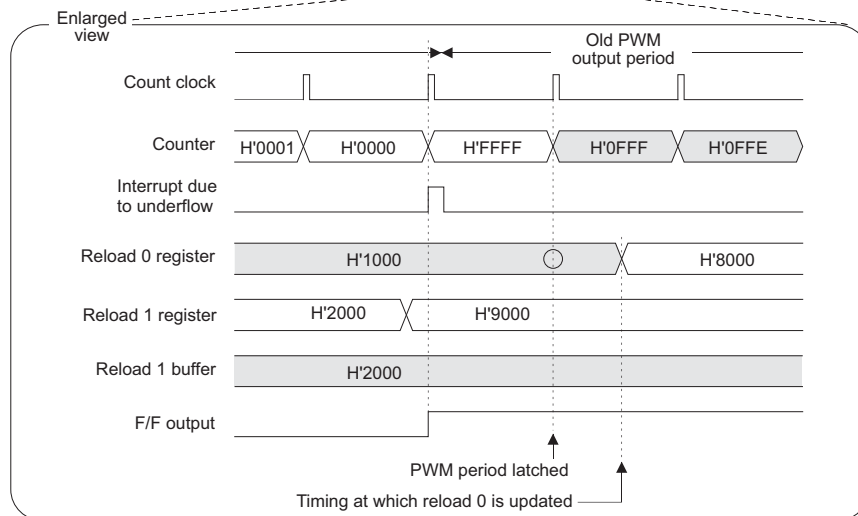
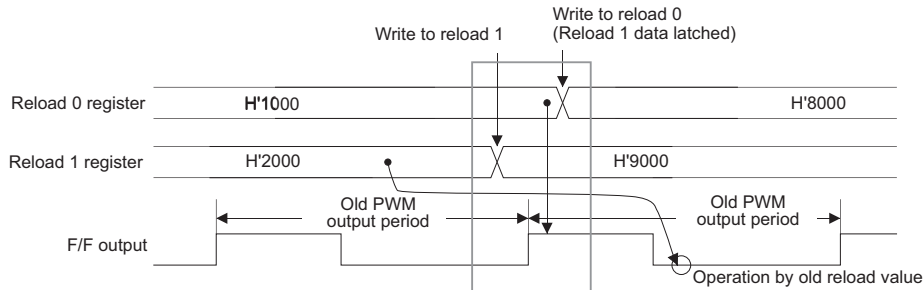
### (3) Notes on using TIO PWM output mode

The following describes precautions to be observed when using TIO PWM output mode.

- If the timer is enabled by external input in the same clock period as count is disabled by writing to the enable bit, the latter has priority so that count is disabled.
- If the counter is accessed for read at the cycle of underflow, the counter value is read as H'FFFF but changes to "reload register value -1" at the next count clock timing.
- Because the timer operates synchronously with the count clock, up to one count clock-dependent delay is generated before F/F output is inverted after writing to the enable bit.



(b) When reload register updates take effect in the next period (reflected one period later)



Note: • This diagram does not show detailed timing information.

Figure 10.4.12 Reload 0 and Reload 1 Register Updates in PWM Output Mode

### 10.4.12 Operation in TIO Single-shot Output Mode (without Correction Function)

#### (1) Outline of TIO single-shot output mode

In single-shot output mode, the timer generates a pulse in width of "reload 0 register set value + 1" only once and then stops.

When the timer is enabled "by writing to the enable bit in software or by external input" after setting the reload 0 register, the counter is loaded with the content of the "reload 0 register -1" and starts counting synchronously with the count clock at the next cycle. The counter counts down and when the minimum count is reached, stops upon underflow.

The F/F output waveform in single-shot output mode is inverted "F/F output level changes from "L" to "H" or vice versa" at startup and upon underflow, generating a single-shot pulse waveform in width of "reload 0 register set value + 1" only once.

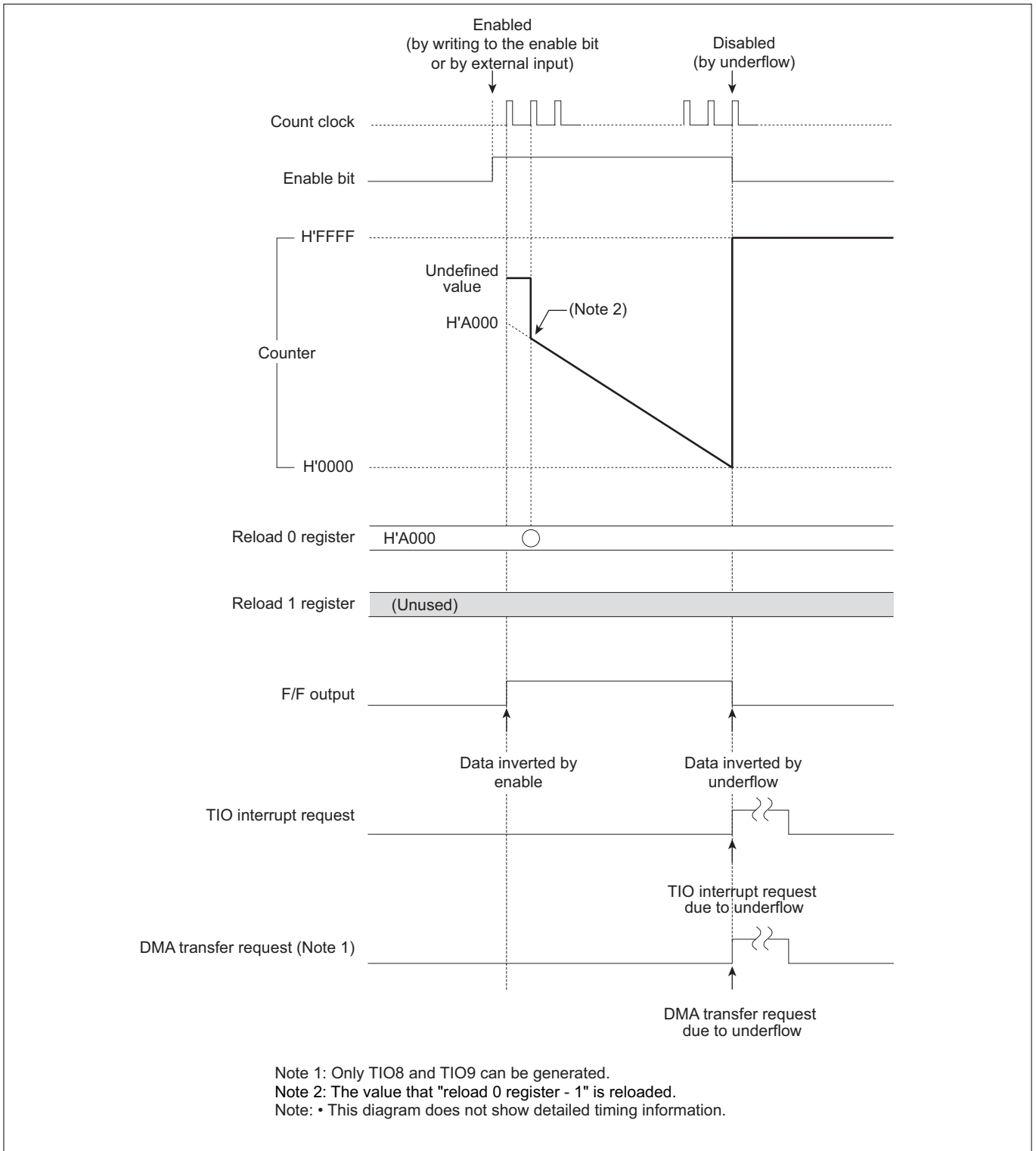
Furthermore, it is possible to generate an interrupt request and a DMA transfer request (for only the TIO8 and TIO9) upon underflow of the counter.

The count value is "reload 0 register set value + 1." (For counting operation, see also Section 10.3.9, "Operation of TOP Single-shot Output Mode.")

#### (2) Notes on using TIO single-shot output mode

The following describes precautions to be observed when using TIO single-shot output mode.

- If the counter stops due to an underflow in the same clock period as the timer is enabled by external input, the former has priority so that the counter stops.
- If the counter stops due to an underflow in the same clock period as count is enabled by writing to the enable bit, the latter has priority so that count is enabled.
- If the timer is enabled by external input in the same clock period as count is disabled by writing to the enable bit, the latter has priority so that count is disabled.
- Because the timer operates synchronously with the count clock, up to one count clock-dependent delay is generated before F/F output is inverted after writing to the enable bit.



**Figure 10.4.13 Typical Operation in TIO Single-shot Output Mode (without Correction Function)**

### 10.4.13 Operation in TIO Delayed Single-shot Output Mode (without Correction Function)

#### (1) Outline of TIO delayed single-shot output mode

In delayed single-shot output mode, the timer generates a pulse in width of "reload 0 register set value + 1" after a finite time equal to "counter set value + 1" only once and then stops.

When the timer is enabled (by writing to the enable bit in software or by external input) after setting the counter and reload 0 register, it starts counting down from the counter's set value synchronously with the count clock. At the cycle after the first counter underflow, it is loaded with "the reload 0 register value -1" and continues counting down. The counter stops when it underflows next time.

The F/F output waveform in delayed single-shot output mode is inverted (F/F output level changes from "L" to "H" or vice versa) when the counter underflows first time and next, generating a single-shot pulse waveform in width of "reload 0 register set value + 1" after a finite time equal to "first set value of counter + 1" only once.

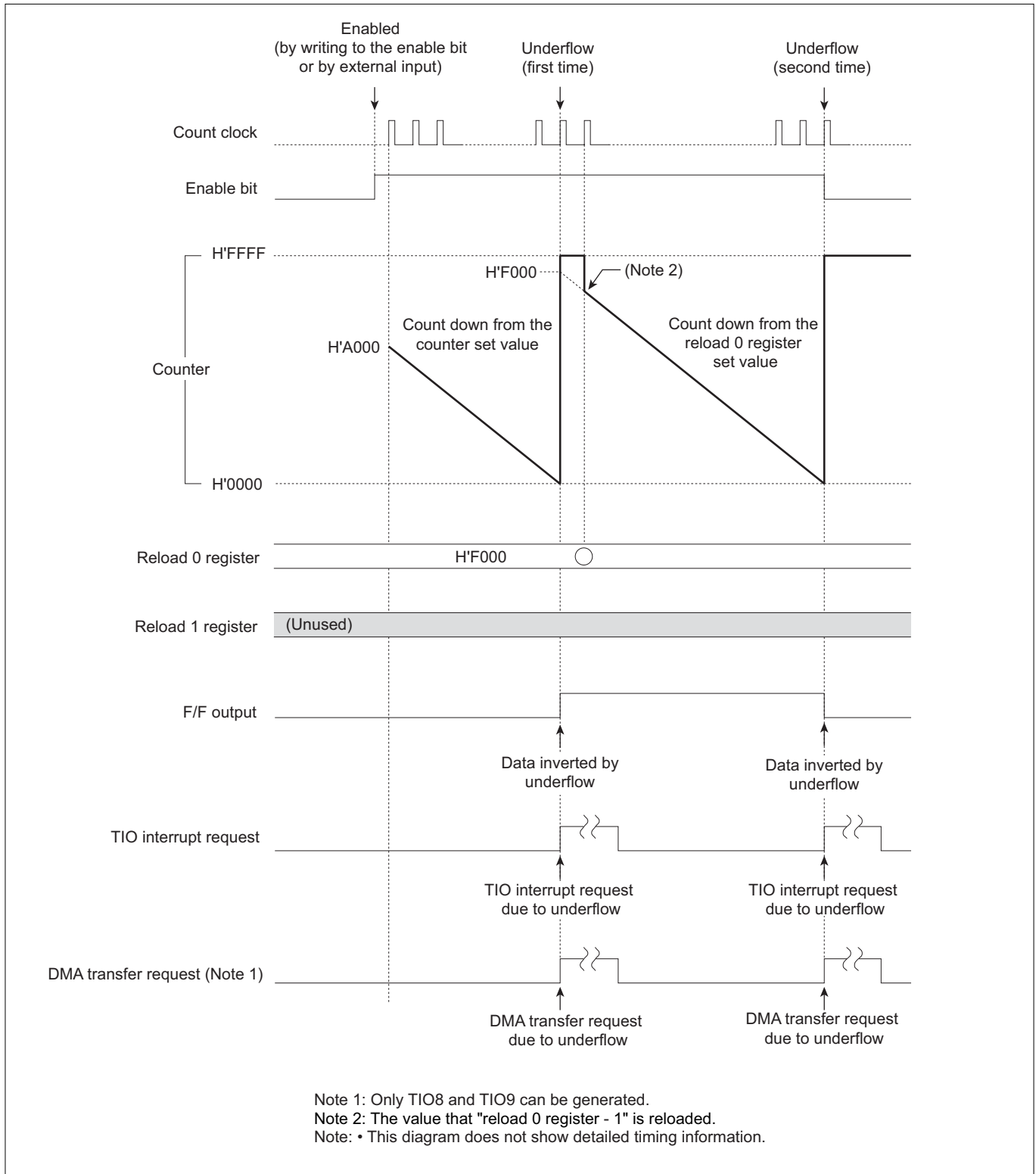
Furthermore, it is possible to generate an interrupt request and a DMA transfer request (for only the TIO8 and TIO9) upon the first and next underflows of the counter.

The "counter set value + 1" and "reload 0 register set value + 1" are effective as count values. (For counting operation, see also Section 10.3.10, "Operation of TOP Delayed Single-shot Output Mode.")

#### (2) Notes on using TIO delayed single-shot output mode

The following describes precautions to be observed when using TIO delayed single-shot output mode.

- If the counter stops due to an underflow in the same clock period as the timer is enabled by external input, the former has priority so that the counter stops.
- If the counter stops due to an underflow in the same clock period as count is enabled by writing to the enable bit, the latter has priority so that count is enabled.
- If the timer is enabled by external input in the same clock period as count is disabled by writing to the enable bit, the latter has priority so that count is disabled.
- If the counter is accessed for read at the cycle of underflow, the counter value is read out as H'FFFF but changes to "reload register value -1" at the next count clock timing.



**Figure 10.4.14 Typical Operation in TIO Delayed Single-shot Output Mode (without Correction Function)**



### 10.4.14 Operation in TIO Continuous Output Mode (without Correction Function)

#### (1) Outline of TIO continuous output mode

In continuous output mode, the timer counts down starting from the set value of the counter and the next cycle when the counter underflows, it is loaded with the value that "the reload 0 register -1." Thereafter, this operation is repeated each time the counter underflows, thus generating consecutive pulses whose waveform is inverted in width of "reload 0 register set value + 1."

When the timer is enabled (by writing to the enable bit in software or by external input) after setting the counter and reload 0 register, it starts counting down from the counter's set value synchronously with the count clock and when the minimum count is reached, generates an underflow. The cycle after this underflow causes the counter to be loaded with the content of "the reload 0 register -1" and start counting over again. Thereafter, this operation is repeated each time an underflow occurs. To stop the counter, disable count by writing to the enable bit in software. The timing for reloading to counter is the cycle after underflow.

The F/F output waveform in continuous output mode is inverted (F/F output level changes from "L" to "H" or vice versa) at startup and upon underflow, generating a waveform of consecutive pulses until the timer stops counting.

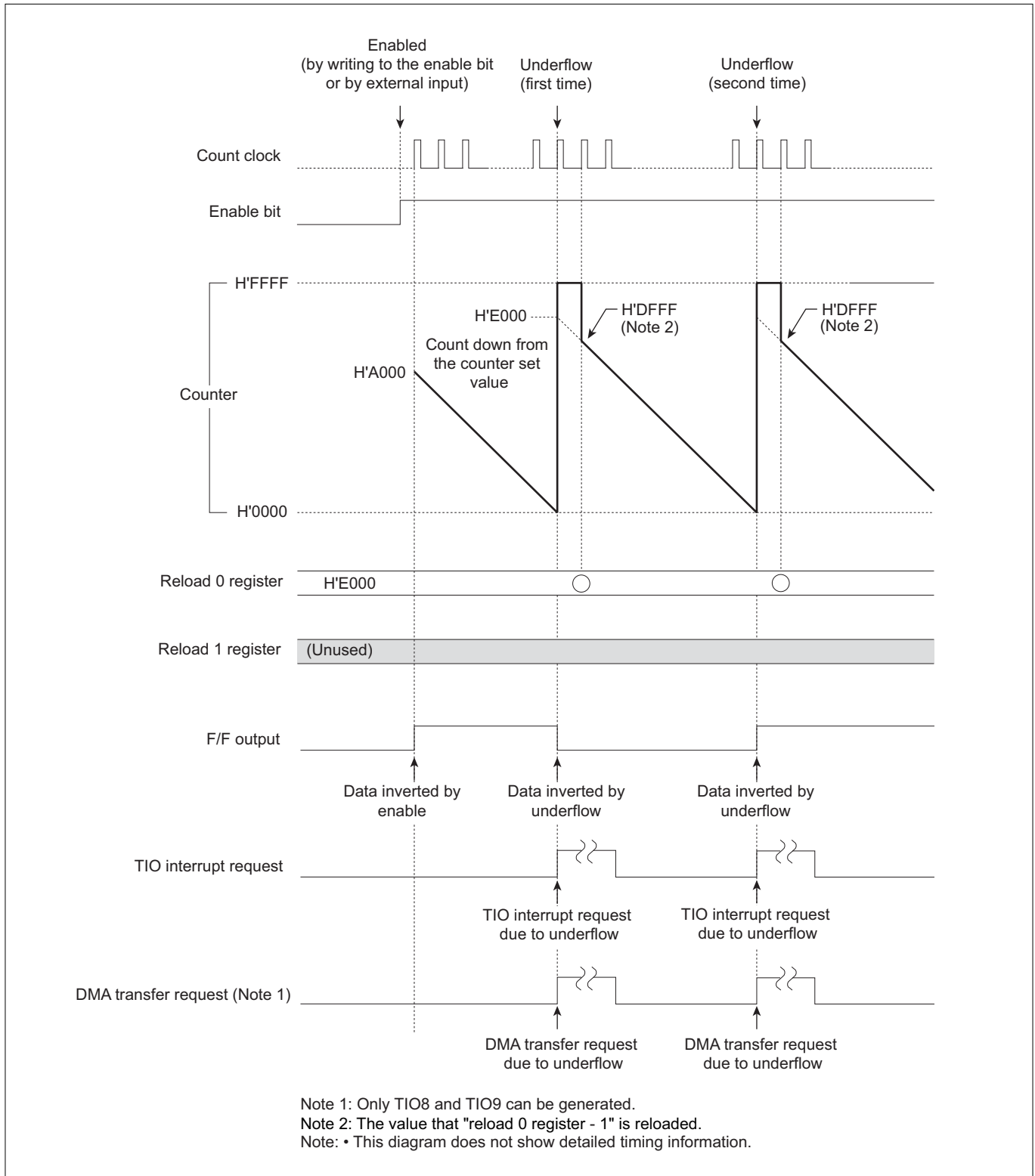
Furthermore, it is possible to generate an interrupt request and a DMA transfer request (for only the TIO8 and TIO9) each time the counter underflows.

The "counter set value + 1" and "reload 0 register set value + 1" are effective as count values. (For counting operation, see also Section 10.3.11, "Operation of TOP Continuous Output Mode.")

#### (2) Notes on using TIO continuous output mode

The following describes precautions to be observed when using TIO continuous output mode.

- If the timer is enabled by external input in the same clock period as count is disabled by writing to the enable bit, the latter has priority so that count is disabled.
- If the counter is accessed for read at the cycle of underflow, the counter value is read out as H'FFFF but changes to "reload register value -1" at the next count clock timing.
- Because the timer operates synchronously with the count clock, up to one count clock-dependent delay is generated before F/F output is inverted after writing to the enable bit.



**Figure 10.4.15 Typical Operation in TIO Continuous Output Mode (without Correction Function)**

## 10.5 TMS (Input-Related 16-Bit Timer)

### 10.5.1 Outline of TMS

TMS (Timer Measure Small) is an input-related 16-bit timer capable of measuring input pulses in two circuit blocks comprising a total of eight channels.

The table below and the diagram in the next page show specifications and a block diagram of TMS, respectively.

**Table 10.5.1 Specifications of TMS (Input-Related 16-Bit Timer)**

Item	Specification
Number of channels	8 channels (2 circuit blocks consisting of 4 channels each, 8 channels in total)
Counter	16-bit up-counter × 2
Measure register	16-bit measure register × 8
Timer startup	Started by writing to the enable bit in software
Interrupt request generation	Can be generated by a counter overflow

### 10.5.2 Outline of TMS Operation

In TMS, when the timer is enabled (by writing to the enable bit in software), the counter starts operating. The counter is a 16-bit up-counter, where when a measure signal is entered from an external device, the counter value is latched into each measure register.

The counter stops counting at the same time count is disabled by writing to the enable bit in software.

TIN and TMS interrupt requests can be generated by external measure signal input and counter overflow, respectively.

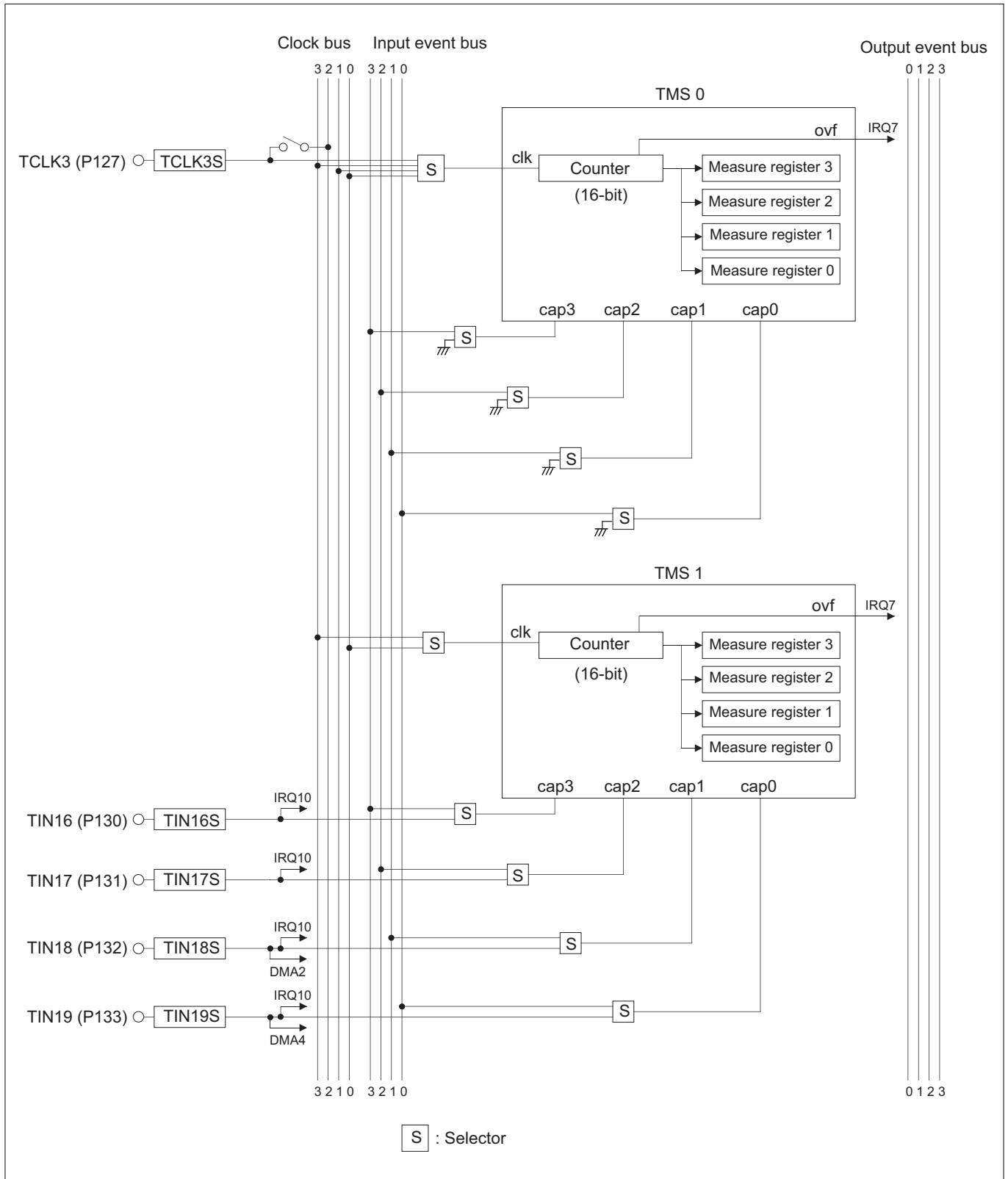


Figure 10.5.1 Block Diagram of TMS (Input-Related 16-Bit Timer)

### <Count clock-dependent delay>

- Because the timer operates synchronously with the count clock, there is a count clock-dependent delay from when the timer is enabled till when it actually starts operating.

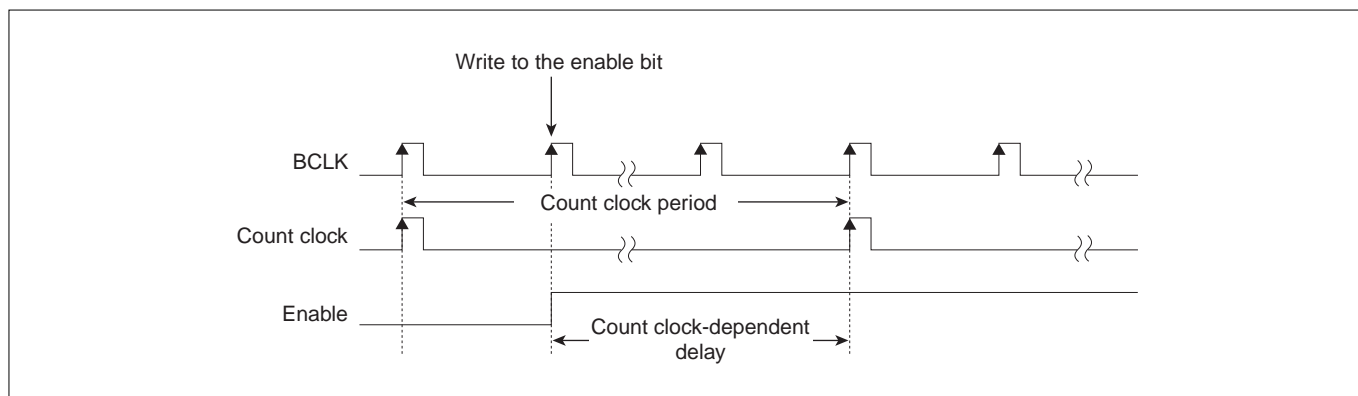


Figure 10.5.2 Count Clock-Dependent Delay

### 10.5.3 TMS Related Register Map

Shown below is a TMS related register map.

#### TMS Related Register Map

Address	b0	+0 address	b7	b8	+1 address	b15	See pages
H'0080 03C0	TMS0 Counter (TMS0CT)						10-127
H'0080 03C2	TMS0 Measure 3 Register (TMS0MR3)						10-127
H'0080 03C4	TMS0 Measure 2 Register (TMS0MR2)						10-127
H'0080 03C6	TMS0 Measure 1 Register (TMS0MR1)						10-127
H'0080 03C8	TMS0 Measure 0 Register (TMS0MR0)						10-127
H'0080 03CA	TMS0 Control Register (TMS0CR)			TMS1 Control Register (TMS1CR)			10-126
	(Use inhibited area)						
H'0080 03D0	TMS1 Counter (TMS1CT)						10-127
H'0080 03D2	TMS1 Measure 3 Register (TMS1MR3)						10-127
H'0080 03D4	TMS1 Measure 2 Register (TMS1MR2)						10-127
H'0080 03D6	TMS1 Measure 1 Register (TMS1MR1)						10-127
H'0080 03D8	TMS1 Measure 0 Register (TMS1MR0)						10-127

## 10.5.4 TMS Control Registers

The TMS control registers are used to select TMS0/1 input events and count clock sources, as well as control count enable. Following two TMS control registers are included:

- TMS0 Control Register (TMS0CR)
- TMS1 Control Register (TMS1CR)

TMS0 Control Register (TMS0CR)

&lt;Address: H'0080 03CA&gt;

b0	1	2	3	4	5	6	b7
TMS0SS0	TMS0SS1	TMS0SS2	TMS0SS3	TMS0CKS			TMS0CEN
0	0	0	0	0	0	0	0

&lt;Upon exiting reset: H'00&gt;

b	Bit Name	Function	R	W
0	TMS0SS0 TMS0 measure 0 source select bit	0: Does not use measure input source 1: Input event bus 0	R	W
1	TMS0SS1 TMS0 measure 1 source select bit	0: Does not use measure input source 1: Input event bus 1	R	W
2	TMS0SS2 TMS0 measure 2 source select bit	0: Does not use measure input source 1: Input event bus 2	R	W
3	TMS0SS3 TMS0 measure 3 source select bit	0: Does not use measure input source 1: Input event bus 3	R	W
4, 5	TMS0CKS TMS0 clock source select bit	00: External input TCLK3 01: Clock bus 0 10: Clock bus 1 11: Clock bus 3	R	W
6	No function assigned. Fix to "0."		0	0
7	TMS0CEN TMS0 count enable bit	0: Stop count 1: Start count	R	W

TMS1 Control Register (TMS1CR)

&lt;Address: H'0080 03CB&gt;

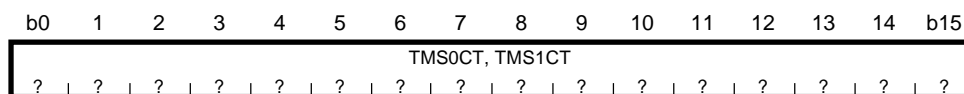
b8	9	10	11	12	13	14	b15
TMS1SS0	TMS1SS1	TMS1SS2	TMS1SS3		TMS1CKS		TMS1CEN
0	0	0	0	0	0	0	0

&lt;Upon exiting reset: H'00&gt;

b	Bit Name	Function	R	W
8	TMS1SS0 TMS1 measure 0 source select bit	0: External input TIN19 1: Input event bus 0	R	W
9	TMS1SS1 TMS1 measure 1 source select bit	0: External input TIN18 1: Input event bus 1	R	W
10	TMS1SS2 TMS1 measure 2 source select bit	0: External input TIN17 1: Input event bus 2	R	W
11	TMS1SS3 TMS1 measure 3 source select bit	0: External input TIN16 1: Input event bus 3	R	W
12	No function assigned. Fix to "0."		0	0
13	TMS1CKS TMS1 clock source select bit	0: Clock bus 0 1: Clock bus 3	R	W
14	No function assigned. Fix to "0."		0	0
15	TMS1CEN TMS1 count enable bit	0: Stop count 1: Start count	R	W

### 10.5.5 TMS Counters (TMS0CT, TMS1CT)

TMS0 Counter (TMS0CT) <Address: H'0080 03C0>  
 TMS1 Counter (TMS1CT) <Address: H'0080 03D0>



<Upon exiting reset: Undefined>

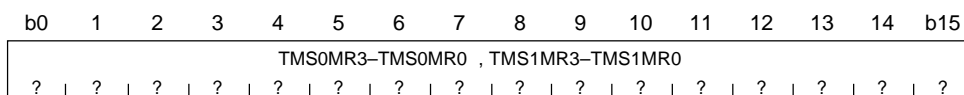
b	Bit Name	Function	R	W
0-15	TMS0CT, TMS1CT	16-bit counter value	R	W

Note: • These registers must always be accessed in halfwords.

The TMS counters are a 16-bit up-counter, which starts counting when the timer is enabled (by writing to the enable bit in software). The counters can be read on-the-fly.

### 10.5.6 TMS Measure Registers (TMS0MR3-0, TMS1MR3-0)

TMS0 Measure 3 Register (TMS0MR3) <Address: H'0080 03C2>  
 TMS0 Measure 2 Register (TMS0MR2) <Address: H'0080 03C4>  
 TMS0 Measure 1 Register (TMS0MR1) <Address: H'0080 03C6>  
 TMS0 Measure 0 Register (TMS0MR0) <Address: H'0080 03C8>  
 TMS1 Measure 3 Register (TMS1MR3) <Address: H'0080 03D2>  
 TMS1 Measure 2 Register (TMS1MR2) <Address: H'0080 03D4>  
 TMS1 Measure 1 Register (TMS1MR1) <Address: H'0080 03D6>  
 TMS1 Measure 0 Register (TMS1MR0) <Address: H'0080 03D8>



<Upon exiting reset: Undefined>

b	Bit Name	Function	R	W
0-15	TMS0MR3-TMS0MR0 TMS1MR3-TMS1MR0	16-bit measured value	R	-

Notes: • These registers are a read-only register.  
 • These registers can be accessed in either byte or halfword.

The TMS measure registers are used to latch counter contents upon event input. The TMS measure registers are a read-only register.

## 10.5.7 Operation of TMS Measure Input

## (1) Outline of TMS measure input

In TMS measure input, when the timer is enabled (by writing to the enable bit in software), it starts counting up synchronously with the count clock. Then when event input to TMS is detected while the timer is operating, the counter value is latched into measure registers 0–3. The timer stops counting at the same time count is disabled by writing to the enable bit.

A TIN interrupt request can be generated by measure signal input from an external device. A TMS interrupt request can be generated when the counter overflows.

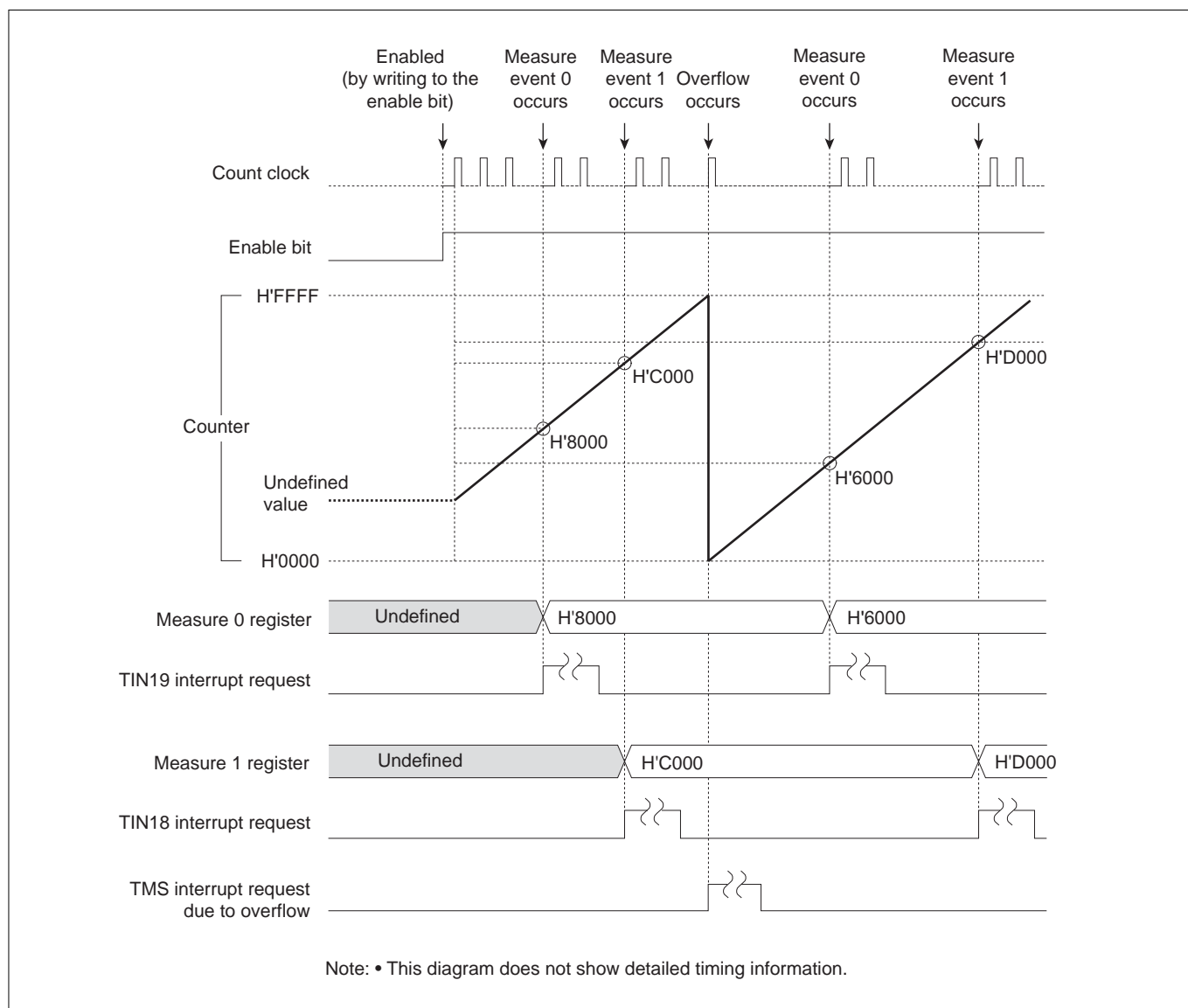


Figure 10.5.3 Typical Operation of TMS Measure Input

## (2) Notes on using TMS measure input

The following describes precautions to be observed when using TMS measure input.

- If measure event input and write to the counter occur in the same clock period, the write value is set in the counter while at the same time latched into the measure register.



## 10.6 TML (Input-Related 32-Bit Timer)

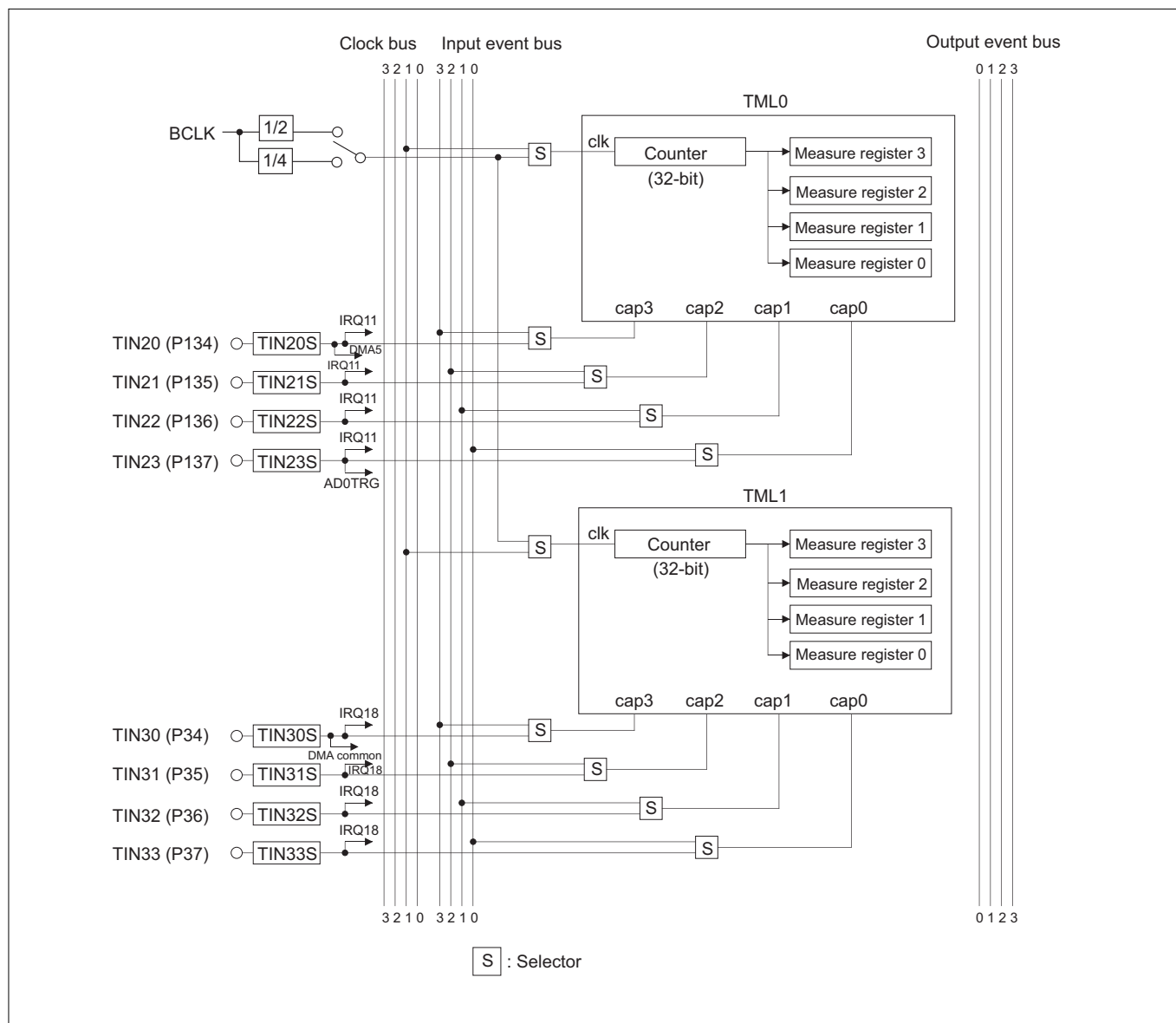
### 10.6.1 Outline of TML

TML (Timer Measure Large) is an input-related 32-bit timer capable of measuring input pulses in two circuit blocks comprising a total of eight channels.

The table and diagram below show specifications and a block diagram of TML, respectively.

**Table 10.6.1 Specifications of TML (Input-Related 32-Bit Timer)**

Item	Specification
Number of channels	8 channels (2 circuit blocks consisting of 4 channels each, 8 channels in total)
Input clock	BCLK/4 (10.0 MHz when f(BCLK) = 40 MHz), BCLK/2 (20.0 MHz when f(BCLK) = 40 MHz) or clock bus 1 input
Counter	32-bit up-counter × 2
Measure register	32-bit measure register × 8
Timer startup	Start counting after exiting the reset state



**Figure 10.6.1 Block Diagram of TML (Input-Related 32-Bit Timer)**

### 10.6.2 Outline of TML Operation

In TML, the timer starts counting upon deassertion of the reset input signal. The counter included in the timer is a 32-bit up-counter, where when a measure event signal is entered from an external device, the counter value at that point in time is stored in each 32-bit measure register.

When the reset input signal is deasserted, the counter starts operating with a BCLK/4 clock, and cannot be stopped once it has started. The counter is idle only when the microcomputer remains reset.

A TIN interrupt request can be generated by external measure signal input. However, no TML counter overflow interrupts are available.

### 10.6.3 TML Related Register Map

Shown below is a TML related register map.

TML Related Register Map

Address	+0 address	b7	b8	+1 address	b15	See pages
H'0080 03E0	TML0 Counter (TML0CT)			(Upper) (TML0CTH)		10-132
H'0080 03E2				(Lower) (TML0CTL)		
	(Use inhibited area)					
H'0080 03EA	(Use inhibited area)			TML0 Control Register (TML0CR)		10-131
	(Use inhibited area)					
H'0080 03F0	TML0 Measure 3 Register (TML0MR3)			(Upper) (TML0MR3H)		10-132
H'0080 03F2				(Lower) (TML0MR3L)		
H'0080 03F4	TML0 Measure 2 Register (TML0MR2)			(Upper) (TML0MR2H)		10-132
H'0080 03F6				(Lower) (TML0MR2L)		
H'0080 03F8	TML0 Measure 1 Register (TML0MR1)			(Upper) (TML0MR1H)		10-132
H'0080 03FA				(Lower) (TML0MR1L)		
H'0080 03FC	TML0 Measure 0 Register (TML0MR0)			(Upper) (TML0MR0H)		10-132
H'0080 03FE				(Lower) (TML0MR0L)		
H'0080 0FE0	TML1 Counter (TML1CT)			(Upper) (TML1CTH)		10-132
H'0080 0FE2				(Lower) (TML1CTL)		
	(Use inhibited area)					
H'0080 0FEA	(Use inhibited area)			TML1 Control Register (TML1CR)		10-131
	(Use inhibited area)					
H'0080 0FF0	TML1 Measure 3 Register (TML1MR3)			(Upper) (TML1MR3H)		10-132
H'0080 0FF2				(Lower) (TML1MR3L)		
H'0080 0FF4	TML1 Measure 2 Register (TML1MR2)			(Upper) (TML1MR2H)		10-132
H'0080 0FF6				(Lower) (TML1MR2L)		
H'0080 0FF8	TML1 Measure 1 Register (TML1MR1)			(Upper) (TML1MR1H)		10-132
H'0080 0FFA				(Lower) (TML1MR1L)		
H'0080 0FFC	TML1 Measure 0 Register (TML1MR0)			(Upper) (TML1MR0H)		10-132
H'0080 0FFE				(Lower) (TML1MR0L)		

## 10.6.4 TML Control Registers

TML0 Control Register (TML0CR)

&lt;Address: H'0080 03EB&gt;

b8	9	10	11	12	13	14	b15
TML0SS0	TML0SS1	TML0SS2	TML0SS3	0	0	0	TML0CKS
0	0	0	0	0	0	0	0

&lt;Upon exiting reset: H'00&gt;

b	Bit Name	Function	R	W
8	TML0SS0 TML0 measure 0 source select bit	0: External input TIN23 1: Input event bus 0	R	W
9	TML0SS1 TML0 measure 1 source select bit	0: External input TIN22 1: Input event bus 1	R	W
10	TML0SS2 TML0 measure 2 source select bit	0: External input TIN21 1: Input event bus 2	R	W
11	TML0SS3 TML0 measure 3 source select bit	0: External input TIN20 1: Input event bus 3	R	W
12–14	No function assigned. Fix to "0."		0	0
15	TML0CKS TML0 clock source select bit	0: BCLK/2 or BCLK/4 (Note 1) 1: Clock bus 1	R	W

Note 1: To select BCLK/2 or BCLK/4, use the PRS012CKS (prescaler 0-2, TML0,1 supplied clock select) bit. For details, refer to Section 10.2.2, "Common Count Clock Select Function."

TML1 Control Register (TML1CR)

&lt;Address: H'0080 0FEB&gt;

b8	9	10	11	12	13	14	b15
TML1SS0	TML1SS1	TML1SS2	TML1SS3	0	0	0	TML1CKS
0	0	0	0	0	0	0	0

&lt;Upon exiting reset: H'00&gt;

b	Bit Name	Function	R	W
8	TML1SS0 TML1 measure 0 source select bit	0: External input TIN33 1: Input event bus 0	R	W
9	TML1SS1 TML1 measure 1 source select bit	0: External input TIN32 1: Input event bus 1	R	W
10	TML1SS2 TML1 measure 2 source select bit	0: External input TIN31 1: Input event bus 2	R	W
11	TML1SS3 TML1 measure 3 source select bit	0: External input TIN30 1: Input event bus 3	R	W
12–14	No function assigned. Fix to "0."		0	0
15	TML1CKS TML1 clock source select bit	0: BCLK/2 or BCLK/4 (Note 1) 1: Clock bus 1	R	W

Note 1: To select BCLK/2 or BCLK/4, use the PRS012CKS (prescaler 0-2, TML0,1 supplied clock select) bit. For details, refer to Section 10.2.2, "Common Count Clock Select Function."

The TML control register is used to select TML input event and count clock.

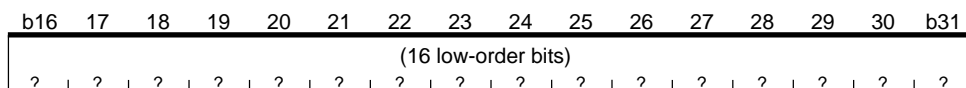
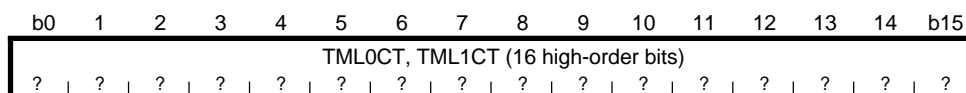
#### 10.6.5 TML Counters

TML0 Counter (TML0CT)

<Address: H'0080 03E0>

TML1 Counter (TML1CT)

<Address: H'0080 0FE0>



<Upon exiting reset: Undefined>

b	Bit Name	Function	R	W
0–31	TML0CT	32-bit counter value	R	W

Note: • These registers must always be accessed wordwise (in 32 bits) beginning with the word boundary (low-order address B'00).

The TML counters are a 32-bit up-counter, which starts counting upon deassertion of the reset input signal. The counters can be read during operation.

#### 10.6.6 TML Measure Registers

TML0 Measure 3 Register (TML0MR3)

<Address: H'0080 03F0>

TML0 Measure 2 Register (TML0MR2)

<Address: H'0080 03F4>

TML0 Measure 1 Register (TML0MR1)

<Address: H'0080 03F8>

TML0 Measure 0 Register (TML0MR0)

<Address: H'0080 03FC>

TML1 Measure 3 Register (TML1MR3)

<Address: H'0080 0FF0>

TML1 Measure 2 Register (TML1MR2)

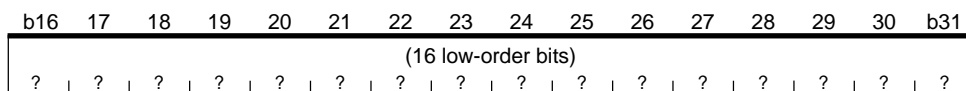
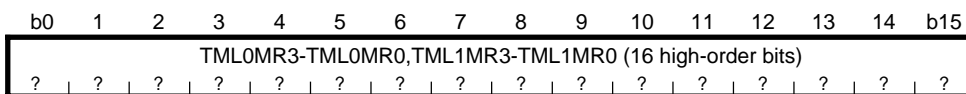
<Address: H'0080 0FF4>

TML1 Measure 1 Register (TML1MR1)

<Address: H'0080 0FF8>

TML1 Measure 0 Register (TML1MR0)

<Address: H'0080 0FFC>



<Upon exiting reset: Undefined>

b	Bit Name	Function	R	W
0–31	TML0MR3–TML0MR0, TML1MR3–TML1MR0	32-bit measure register value	R	–

Notes: • These registers are a read-only register.

• These registers must always be accessed wordwise (in 32 bits) beginning with the word boundary (low-order address B'00).

The TML measure registers are a 32-bit register, which is used to latch the counter content upon event input. The TML measure registers can only be read, and cannot be written to.

### 10.6.7 Operation of TML Measure Input

#### (1) Outline of TML measure input

In TML measure input, when the reset input signal is deasserted, the counter starts counting up synchronously with the count clock. Upon event input to measure registers 0–3, the counter value is latched into each measure register.

A TIN interrupt request can be generated by measure signal input from an external device. However, no TML counter overflow interrupts are available.

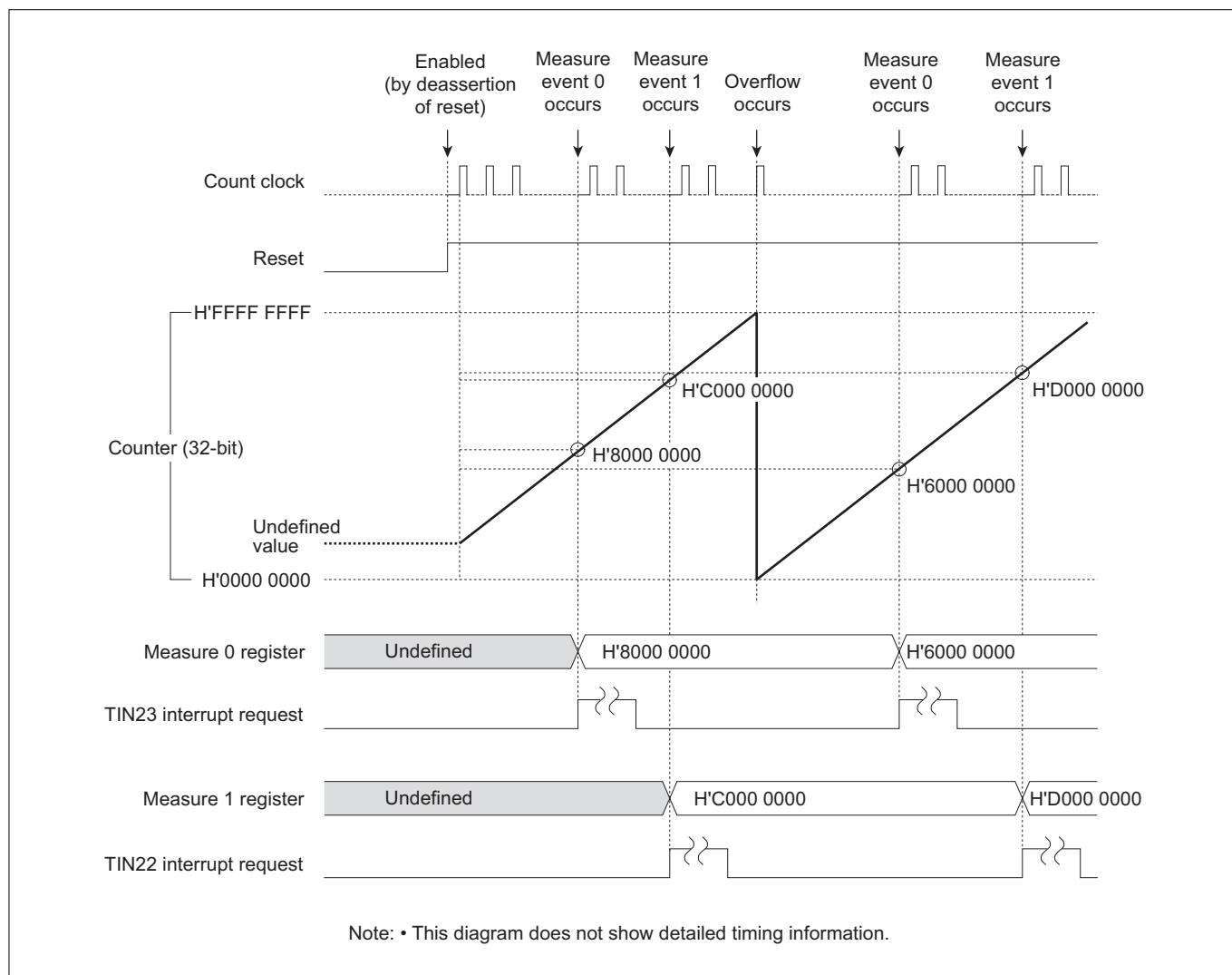


Figure 10.6.2 Typical Operation of TML Measure Input

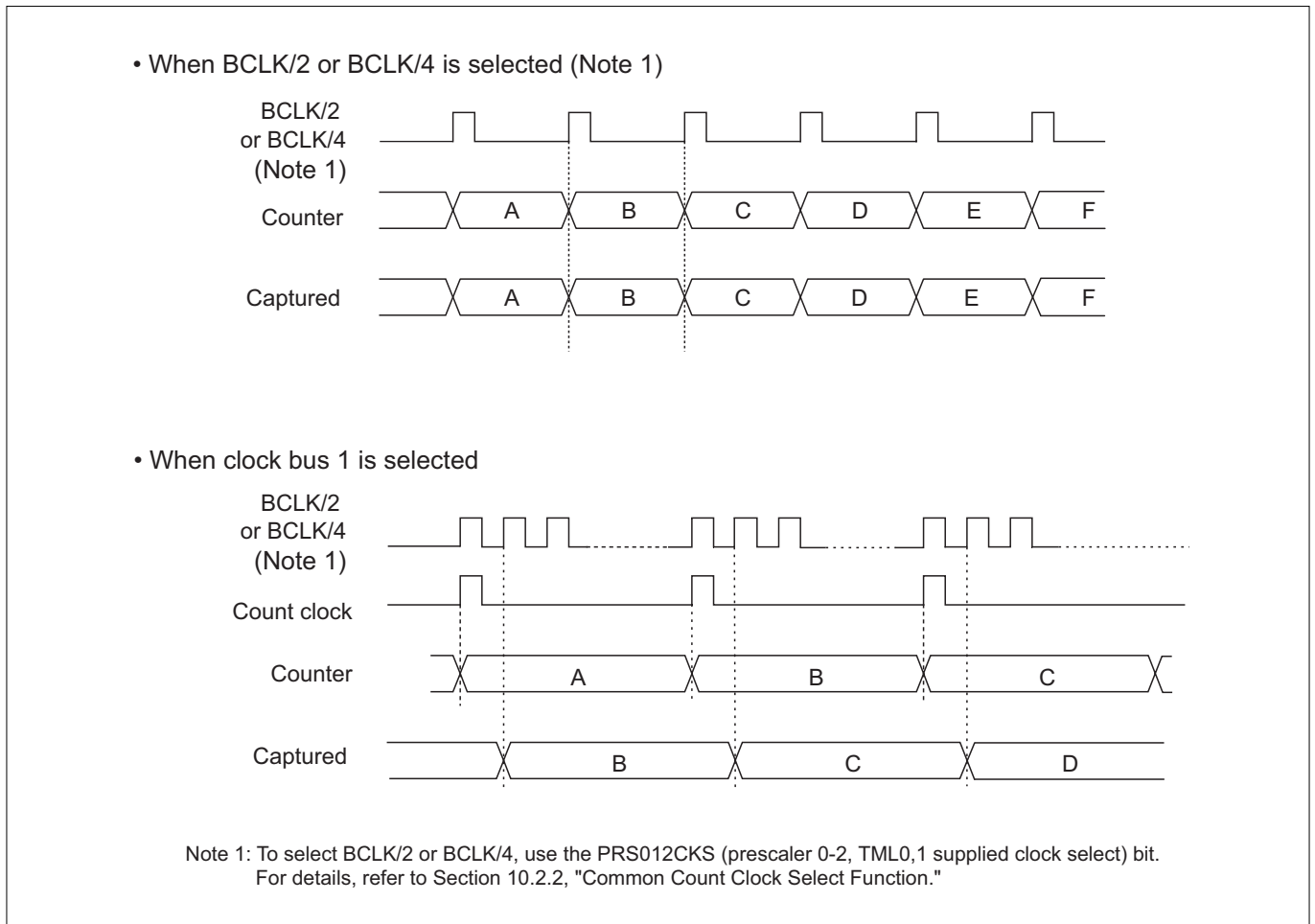
#### (2) Notes on using TML measure input

The following describes precautions to be observed when using TML measure input.

- If measure event input and write to the counter occur in the same clock period, the write value is set in the counter, whereas the up-count value (before being rewritten) is latched into the measure register.
- If clock bus 1 is selected and any clock other than BCLK/2 or BCLK/4 (Note 1) is used for the timer, by divided by internal prescaler PRS1, the value captured into the measure register is one count larger the counter value. During the count clock to BCLK/2 or BCLK/4 (Note 1) period interval, however, the captured value is exactly the counter value.

The diagram below shows the relationship between counter operation and the valid data that can be captured.

Note 1: To select BCLK/2 or BCLK/4, use the PRS012CKS (prescaler 0-2, TML0,1 supplied clock select) bit. For details, refer to Section 10.2.2, "Common Count Clock Select Function."



**Figure 10.6.3 Mistimed Counter Value and the Captured Value**

## 10.7 TID (Input-Related 16-Bit Timer)

### 10.7.1 Outline of TID

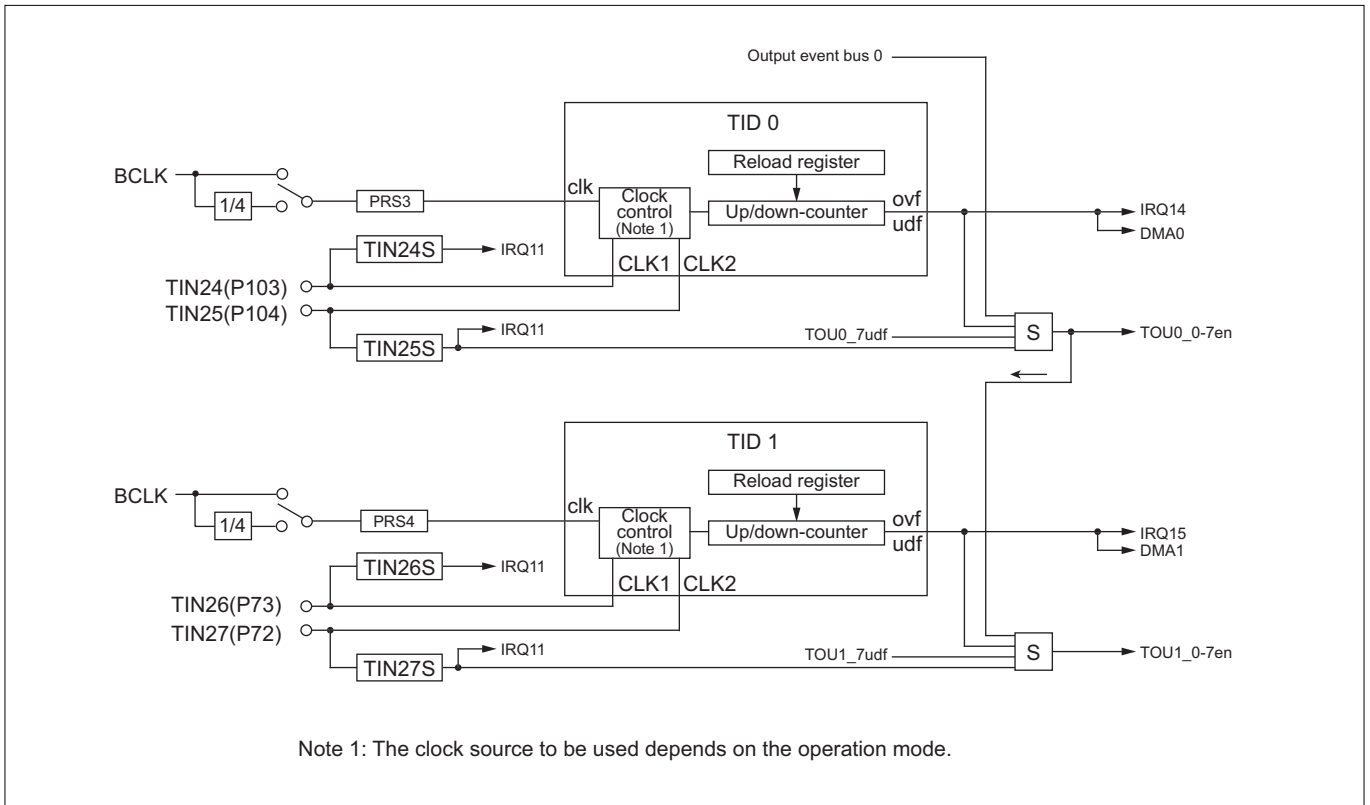
TID (Timer Input Derivation) is an input-related 16-bit timer, whose operation mode can be selected from the following by mode switching in software, one at a time:

- Fixed period count mode
- Event count mode
- Multiply-by-4 event count mode
- Up/down event count mode

The table below and the diagram in the next page show specifications and a block diagram of TID, respectively.

**Table 10.7.1 Specifications of TID (Input-Related 16-Bit Timer)**

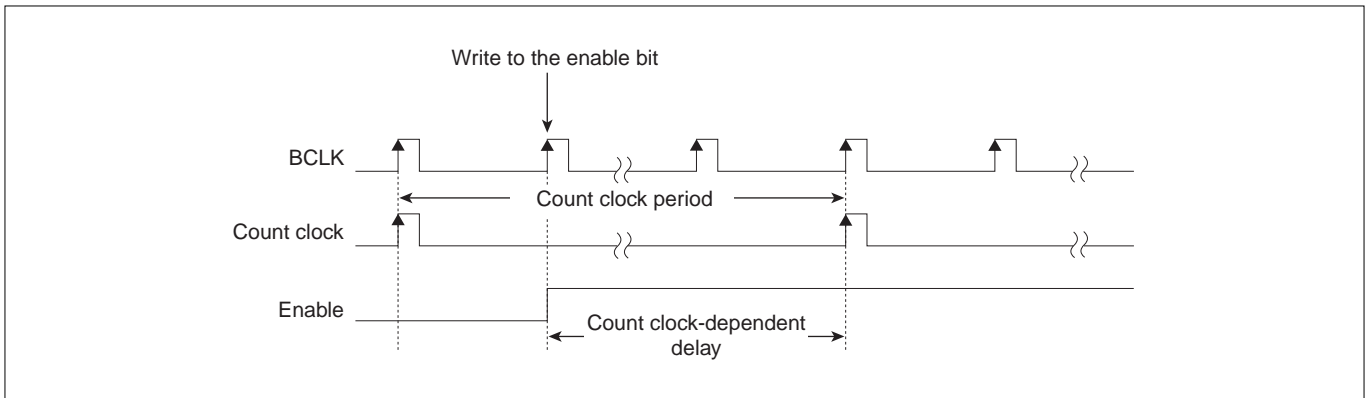
Item	Specification
Number of channels	2 channels
Counter	16-bit up/down-counter
Reload register	16-bit reload register
Timer startup	Started by writing to the enable bit in software
Operation mode	<Input modes> <ul style="list-style-type: none"> <li>• Fixed period count mode</li> <li>• Event count mode</li> <li>• Multiply-by-4 event count mode</li> <li>• Up/down event count mode</li> </ul>
Interrupt request generation	Can be generated by counter underflow and overflow
DMA transfer request generation	Can be generated by counter underflow and overflow



**Figure 10.7.1 Block Diagram of TID (Input-Related 16-Bit Timer)**

### <Count clock-dependent delay>

- Because the timer operates synchronously with the count clock, up to one count clock-dependent delay is generated by the time when the timer actually starts operating after writing to the enable bit.



**Figure 10.7.2 Count Clock Dependent Delay**



## 10.7.2 TID Related Register Map

Shown below is a TID related register map.

## TID Related Register Map

Address	b0	+0 address	b7	b8	+1 address	b15	See pages
H'0080 078C	TID0 Counter (TID0CT)						10-140
H'0080 078E	TID0 Reload Register (TID0RL)						10-140
H'0080 07D0	TID0 Control & Prescaler 3 Enable Register (TID0PRS3EN)						10-138
H'0080 0B8C	TID1 Counter (TID1CT)						10-140
H'0080 0B8E	TID1 Reload Register (TID1RL)						10-140
H'0080 0BD0	TID1 Control & Prescaler 4 Enable Register (TID1PRS4EN)						10-139

## 10.7.3 TID Control &amp; Prescaler Enable Registers

TID0 Control &amp; Prescaler 3 Enable Register (TID0PRS3EN)

&lt;Address: H'0080 07D1&gt;

b8	9	10	11	12	13	14	b15
TID0M			TID0CEN	TOU0ENS			PRS3EN
0	0	0	0	0	0	0	0

&lt;Upon exiting reset: H'00&gt;

b	Bit Name	Function	R	W
8–10	TID0M TID0 operation mode select bit	000: Fixed period count mode 001: Fixed period count mode 010: Multiply-by-4 event count mode 011: Event count mode 100: Fixed period count mode 101: Fixed period count mode 110: Multiply-by-4 event count mode 111: Up/down event count mode	R	W
11	TID0CEN TID0 count enable bit	0: Stop TID0 count 1: Start TID0 count	R	W
12–14	TOU0ENS TOU0 enable source select bit	000: Disable event enable 001: Disable event enable 010: TID0 underflow/overflow 011: TOU0_7 underflow 100: Disable event enable 101: Disable event enable 110: Output event bus 0 111: External input TIN25 signal	R	W
15	PRS3EN Prescaler 3 enable bit	0: Stop prescaler 3 count 1: Start prescaler 3 count	R	W

Note: • Operation mode can only be set or changed while the counter is inactive.

The TID0 Control & Prescaler 3 Enable Register is used to select TID0 operation mode (Fixed period count, Event count, Multiply-by-4 event count or Up/down event count mode), as well as select TOU0\_0–7 timer enable sources and control prescaler 3 startup.

TID1 Control &amp; Prescaler 4 Enable Register (TID1PRS4EN)

&lt;Address: H'0080 0BD1&gt;

b8	9	10	11	12	13	14	b15
TID1M			TID1CEN	TOU1ENS			PRS4EN
0	0	0	0	0	0	0	0

&lt;Upon exiting reset: H'00&gt;

b	Bit Name	Function	R	W
8–10	TID1M TID1 operation mode select bit	000: Fixed period count mode 001: Fixed period count mode 010: Multiply-by-4 event count mode 011: Event count mode 100: Fixed period count mode 101: Fixed period count mode 110: Multiply-by-4 event count mode 111: Up/down event count mode	R	W
11	TID1CEN TID1 count enable bit	0: Stop TID1 count 1: Start TID1 count	R	W
12–14	TOU1ENS TOU1 enable source select bit	000: Disable event enable 001: Disable event enable 010: TID1 underflow/overflow 011: TOU1_7 underflow 100: Disable event enable 101: Disable event enable 110: TOU0 startup source (Note 1) (The enable source selected by TOU0ENS) 111: External input TIN27 signal	R	W
15	PRS4EN Prescaler 4 enable bit	0: Stop prescaler 4 count 1: Start prescaler 4 count	R	W

Note 1: Any event must be selected using the TOU0 enable source select bit.

Note: • Operation mode can only be set or changed while the counter is inactive.

The TID1 Control & Prescaler 4 Enable Register is used to select TID1 operation mode (Fixed period count, Event count, Multiply-by-4 event count or Up/down event count mode), as well as select TOU1\_0–7 timer enable sources and control prescaler 4 startup.

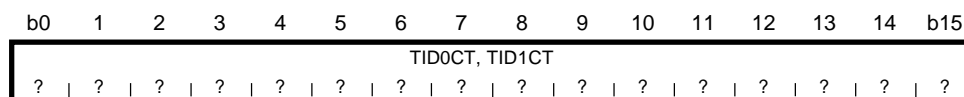
## 10.7.4 TID Counters (TID0CT and TID1CT)

TID0 Counter (TID0CT)

&lt;Address: H'0080 078C&gt;

TID1 Counter (TID1CT)

&lt;Address: H'0080 0B8C&gt;



&lt;Upon exiting reset: Undefined&gt;

b	Bit Name	Function	R	W
0–15	TID0CT, TID1CT	16-bit counter value	R	W

Note: • These registers must always be accessed in halfwords.

The TID counters are a 16-bit up/down-counter. After the timer is enabled (by writing to the enable bit in software), the counter starts counting synchronously with the count clock.

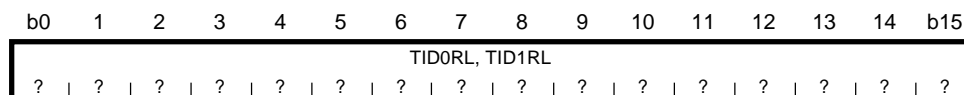
## 10.7.5 TID Reload Registers (TID0RL and TID1RL)

TID0 Reload Register (TID0RL)

&lt;Address: H'0080 078E&gt;

TID1 Reload Register (TID1RL)

&lt;Address: H'0080 0B8E&gt;



&lt;Upon exiting reset: Undefined&gt;

b	Bit Name	Function	R	W
0–15	TID0RL, TID1RL	16-bit reload register value	R	W

Note: • These registers must always be accessed in halfwords.

The TID reload registers are used to reload data into the TID counter registers (TID0CT and TID1CT).

The content of "the reload register -1" is loaded into the counter synchronously with the count clock in the following timing:

- At the next cycle when the counter is enabled in fixed period count mode
- At the next cycle when the counter has underflowed in fixed period count mode

Simply because data is written to the reload register does not mean that the data is loaded into the counter. The counter is loaded with data in only the above cases.

### 10.7.6 Outline of Each Mode of TID

Each mode of TID is outlined below. TID modes can be selected from the following, only one at a time.

#### (1) Fixed period count mode

In fixed period count mode, the timer uses a reload register to generate an interrupt request at intervals of "reload register set value + 1."

Note: • TINn cannot be used as a clock source.

When the timer is enabled (by writing to the enable bit in software) after setting the reload register (initial value being undefined), the counter is loaded with the content of "the reload register - 1" and starts counting synchronously with the count clock at the next cycle. The counter counts down and when it underflows after reaching the minimum count, the counter is loaded with the content of "the reload register - 1" and continues counting. To stop the counter, disable count by writing to the enable bit in software. An interrupt request and a DMA transfer request can be generated each time the counter underflows.

The "reload register set value + 1" is effective as count value.

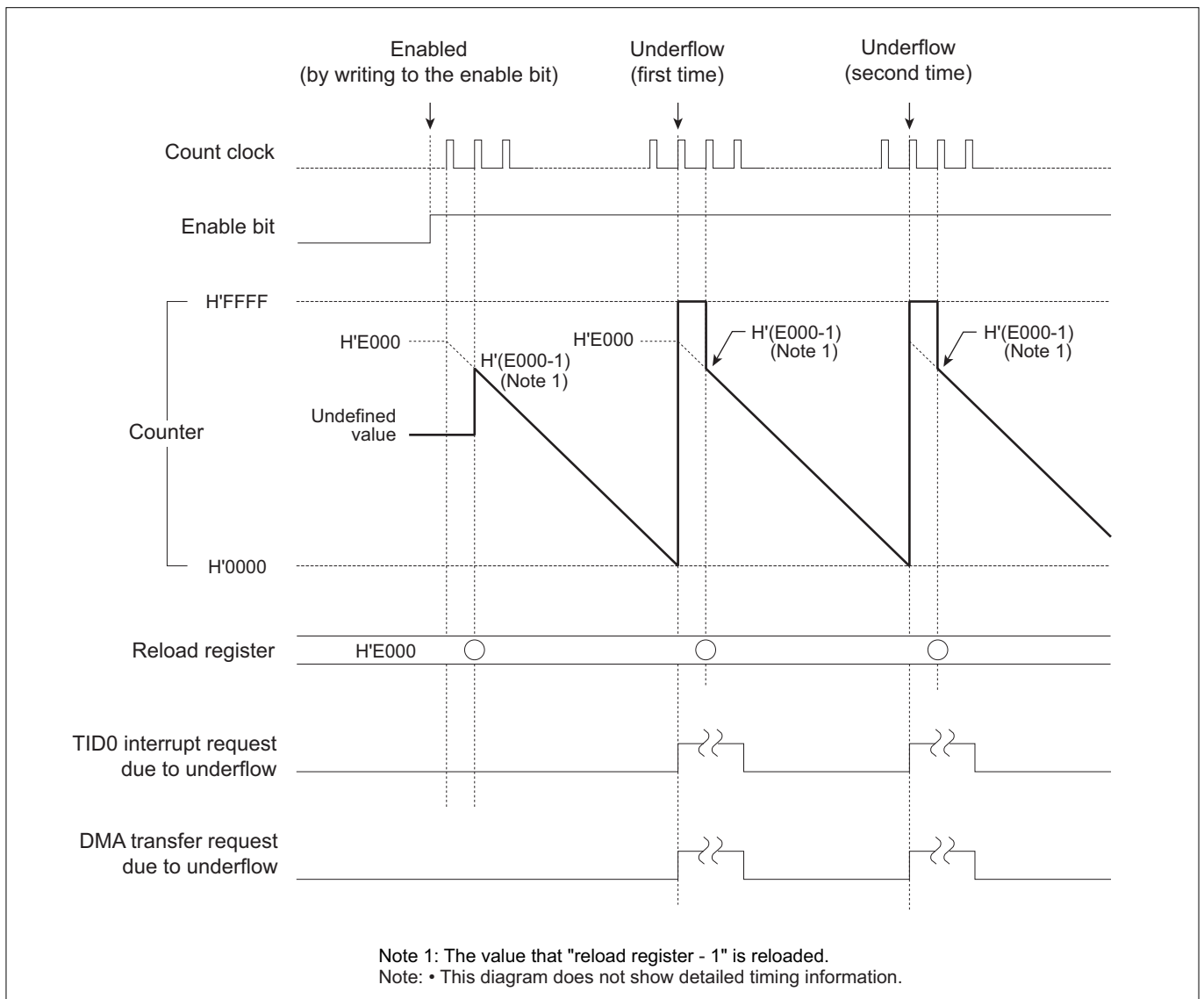


Figure 10.7.3 Typical Operation in TID Fixed Period Count Mode

**(2) Event count mode**

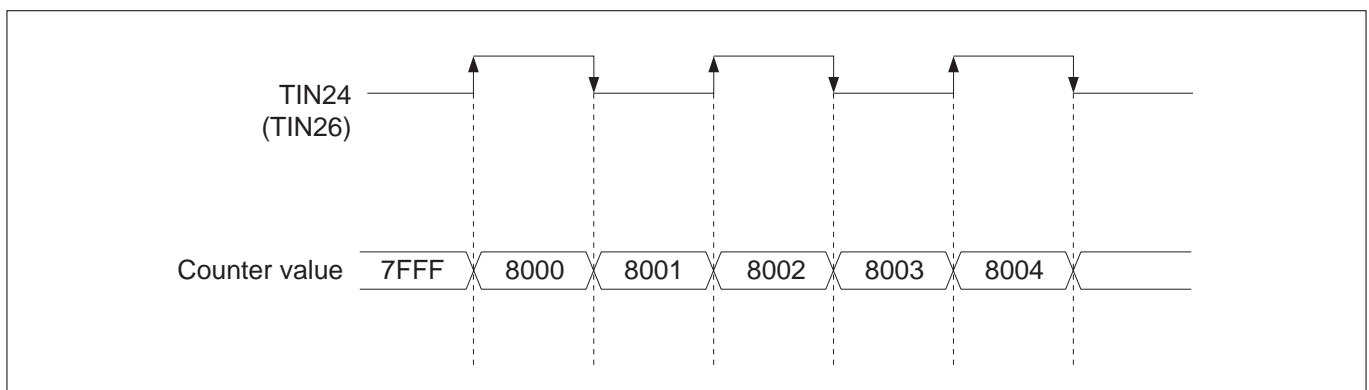
In event count mode, the timer uses an external input signal (TIN24 or TIN26) as the clock source for the counter.

Note: • TIN25 and TIN27 cannot be used as the clock source for the counter.

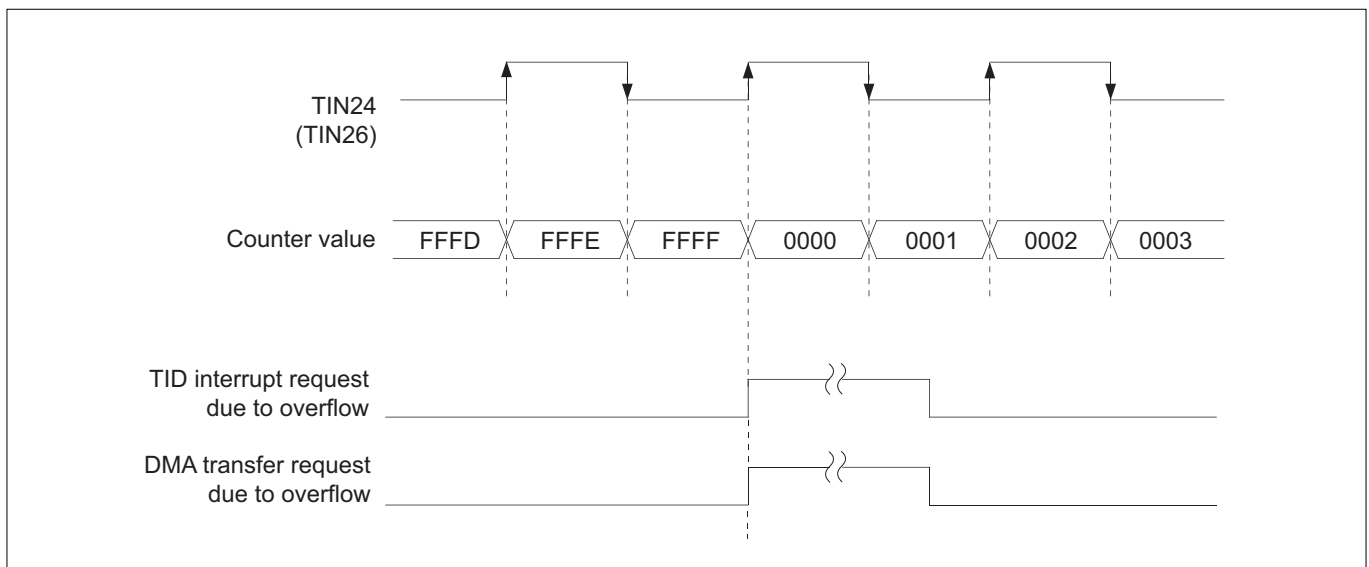
By detecting the rising and falling edges of the external input signal (TIN24 or TIN26), the timer generates clock pulses synchronized to the microcomputer's internal clock. When after setting the counter the timer is enabled (by writing to the enable bit in software), the counter starts counting up from the set count value synchronously with the generated clock.

An interrupt request and a DMA transfer request can be generated by a counter overflow.

To stop the counter, disable count by writing to the enable bit in software or fix the external input signal either "H" or "L."



**Figure 10.7.4 Typical Operation in TID Event Count Mode (Basic Operation)**



**Figure 10.7.5 Typical Operation in TID Event Count Mode (when Overflow Occurs)**

**(3) Multiply-by-4 event count mode**









In multiply-by-4 event count mode, the timer uses two external input signals in pairs (TIN24 and TIN25 or TIN26 and TIN27) as the clock sources for the counter. The count direction is switched between up-count and down-count depending on the status of the two input signals.

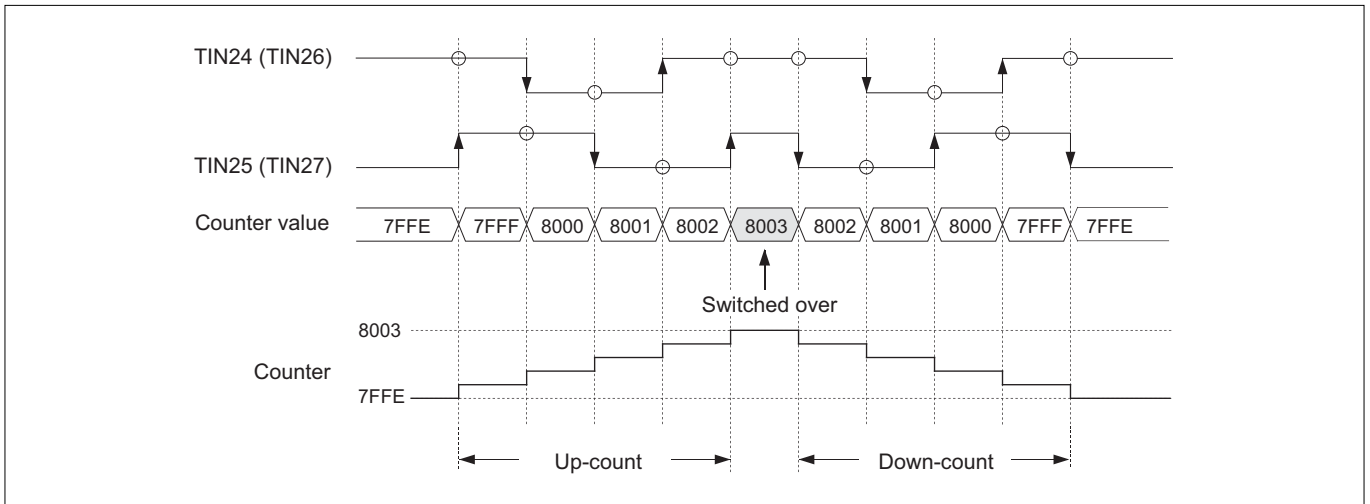
By detecting the rising and falling edges on both of the two external input signals, the timer generates clock pulses synchronized to the microcomputer's internal clock. When after setting the counter the timer is enabled (by writing to the enable bit in software), the counter starts counting synchronously with the generated clock. To know whether the counter counts up or counts down, see Table 10.7.2 below.

An interrupt request and a DMA transfer request can be generated when the counter underflows or overflows.

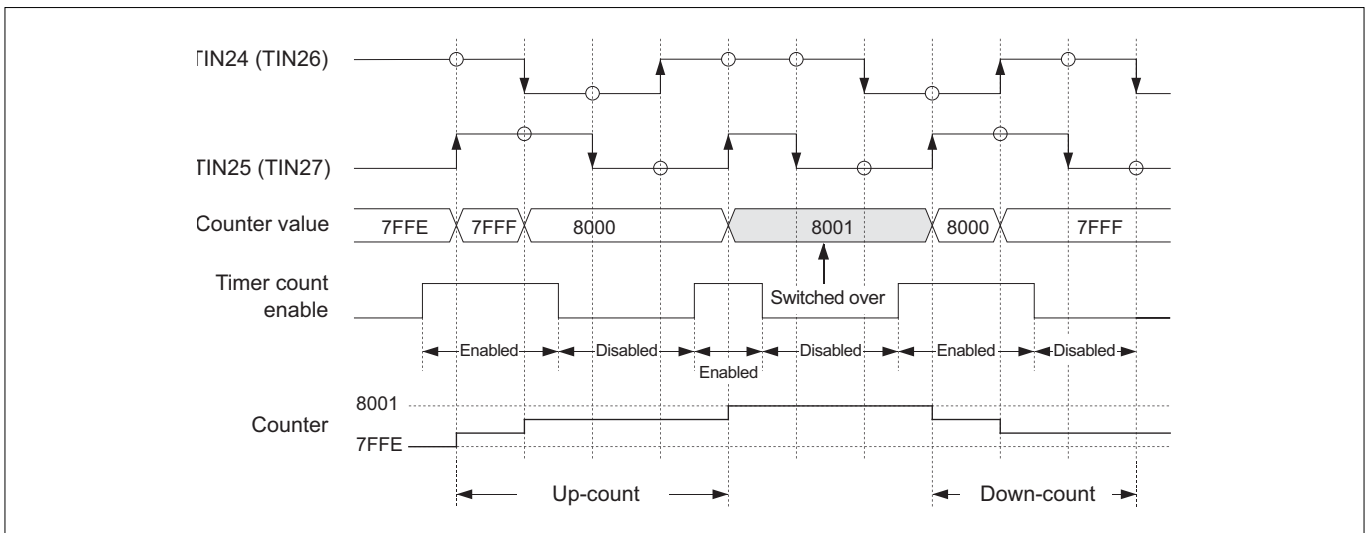
To stop the counter, disable count by writing to the enable bit in software or fix the external input signals either "H" or "L."

**Table 10.7.2 Count Direction during Multiply-by-4 Event Count Mode**

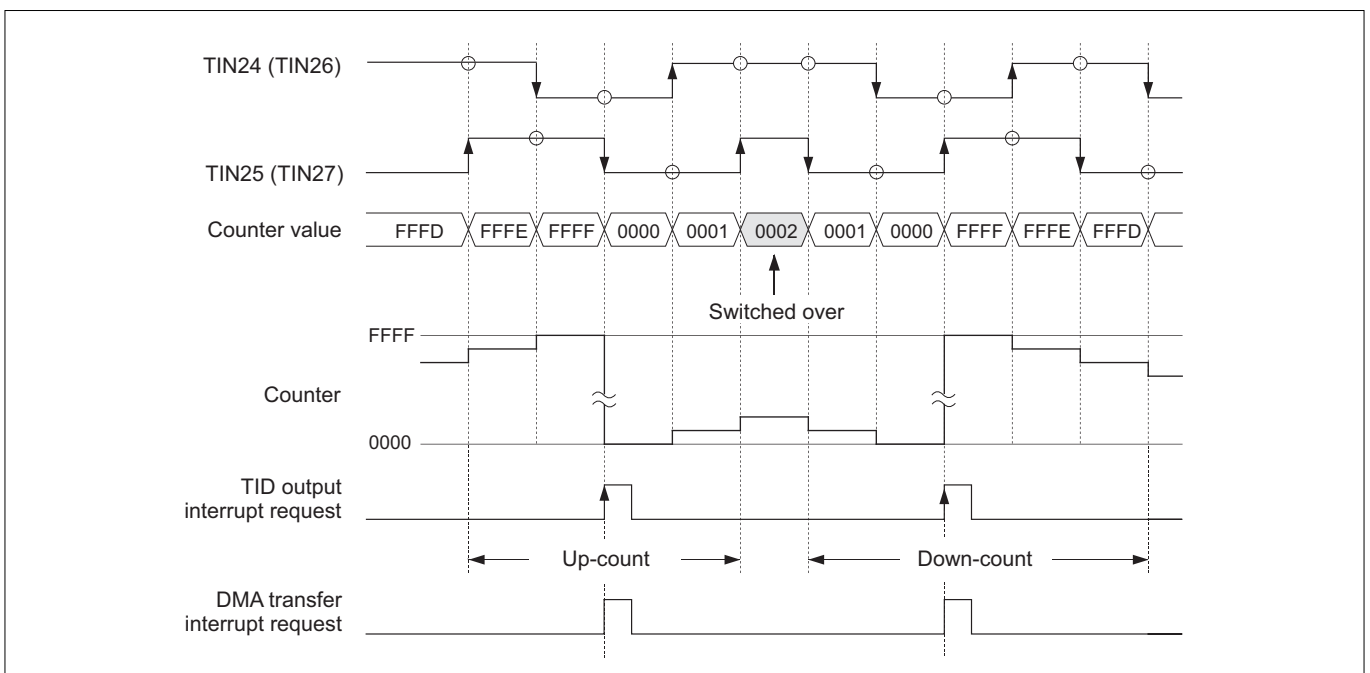
Input	Count Direction							
	Up-count				Down-count			
TIN24 (TIN26)	H		L		H		L	
TIN25 (TIN27)		H		L		L		H



**Figure 10.7.6 Multiply-by-4 Count Operation (Switchover Timing)**



**Figure 10.7.7 Multiply-by-4 Count Operation (Count Enabled/Disabled)**



**Figure 10.7.8 Multiply-by-4 Count Operation (Interrupt Request Timing)**



### (4) Up/down event count mode

In up/down event count mode, the timer uses one of two-channel external input signals (TIN24 or TIN26) as the clock source for the counter and the other (TIN25 or TIN27) as an up/down select signal.

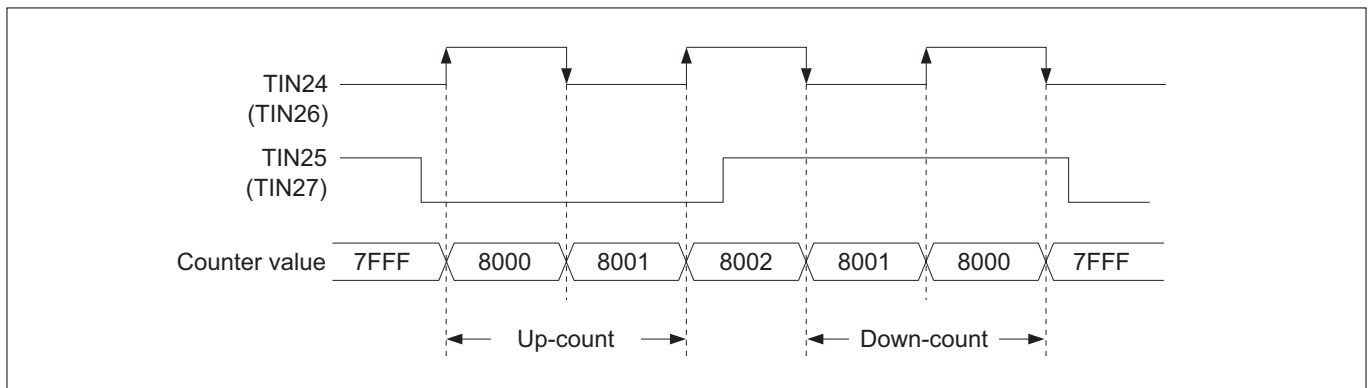
The counter is switched between up-count and down-count depending on the status of the up/down select input signal. By detecting the rising and falling edges of the external input signal selected as the clock source, the timer generates clock pulses synchronized to the microcomputer's internal clock. When after setting the counter the timer is enabled, the counter starts counting up or down synchronously with the generated clock. The count direction is determined by the level of the up/down select input signal (see Table 10.7.3). An interrupt request and a DMA transfer request can be generated when the counter underflows or overflows.

To stop the counter, disable count by writing to the enable bit in software or fix the external input signal selected as the clock source either "H" or "L."

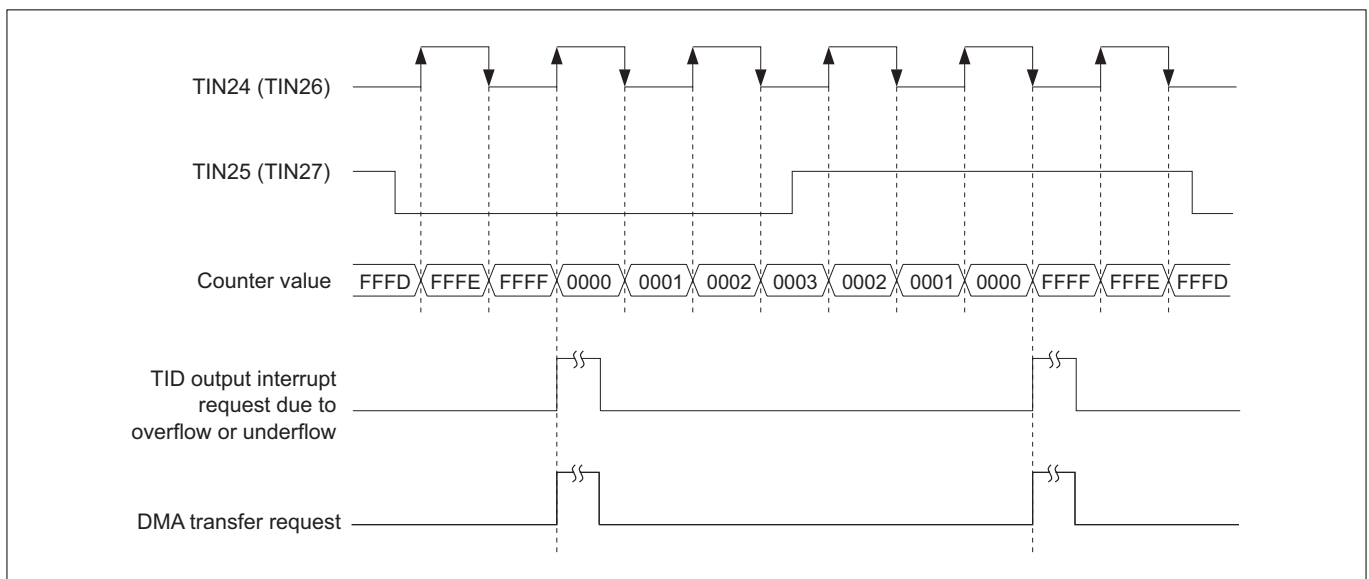
Note that TIN25 and TIN27 cannot be used as the clock source.

**Table 10.7.3 Count Direction during Up/Down Event Count Mode**

Input	Count Direction	
	Up-count	Down-count
TIN24 (TIN26)		
TIN25 (TIN27)	"L" level	"H" level



**Figure 10.7.9 Up/Down Count Operation**



**Figure 10.7.10 Up/Down Count Operation (Interrupt Request Timing)**

## 10.8 TOU (Output-Related 24-Bit Timer)

### 10.8.1 Outline of TOU

TOU (Timer Output Unification) is an output-related 24-bit timer, whose operation mode can be selected from the following by mode switching in software, one at a time.

<Output modes without correction function>

- PWM output mode
- Single-shot PWM output mode
- Delayed single-shot output mode
- Single-shot output mode
- Continuous output mode

The table below and the diagram in the next page show specifications and a block diagram of TOU, respectively.

**Table 10.8.1 Specifications of TOU (Output-Related 24-Bit Timer)**

Item	Specification
Number of channels	16 channels (8 channels × 2 circuit blocks)
Counter	24-bit down-counter (or 16-bit down counter when in PWM output or single-shot PWM output mode)
Reload register	24-bit reload register (or 16-bit reload register when in PWM output or single-shot PWM output mode)
Timer startup	TOU0: <ul style="list-style-type: none"> <li>• Writing to the enable bit in software</li> <li>• TID0 underflow/overflow signal</li> <li>• TOU0_7 underflow signal</li> <li>• Output event bus 0 signal</li> <li>• External input TIN25 signal</li> </ul> TOU1: <ul style="list-style-type: none"> <li>• Writing to the enable bit in software</li> <li>• TID1 underflow/overflow signal</li> <li>• TOU1_7 underflow signal</li> <li>• TOU0 cause of start signal (Event enable must be selected by TOU0)</li> <li>• External input TIN27 signal</li> </ul>
Mode switching	<Output modes without correction function> <ul style="list-style-type: none"> <li>• PWM output mode</li> <li>• Single-shot PWM output mode</li> <li>• Delayed single-shot output mode</li> <li>• Single-shot output mode</li> <li>• Continuous output mode</li> </ul>
Interrupt request generation	Can be generated by a counter underflow
DMA transfer request generation	Can be generated by a counter underflow

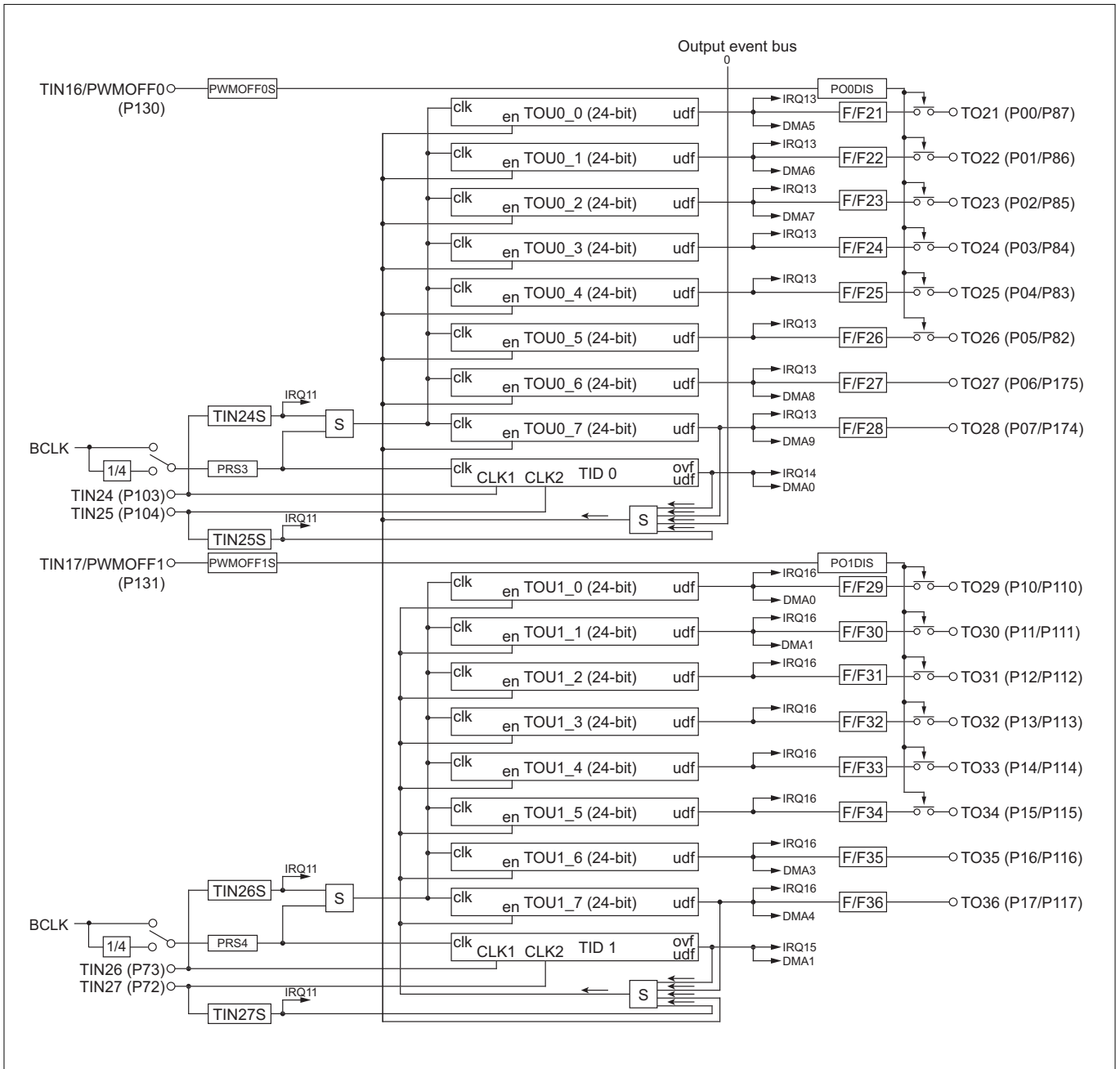


Figure 10.8.1 Block Diagram of TOU (Output-Related 24-Bit Timer)

### 10.8.2 Outline of Each Mode of TOU

Each mode of TOU is outlined below. Modes on each TOU channel can be selected from the following, only one at a time.

#### (1) PWM output mode (without correction function)

In PWM output mode, the timer uses two reload registers to generate a waveform with a given duty cycle. During PWM output mode, the timer operates as a 16-bit timer.

When the timer is enabled after setting the initial values in the reload 0 and reload 1 registers, the counter is loaded with the value that "the reload 0 register -1" and starts counting down synchronously with the count clock. At the cycle after first time the counter underflows, it is loaded with the contents that "the reload 1 register -1" and continues counting. Thereafter, the counter is loaded with the reload 0 and reload 1 register values alternately each time an underflow occurs. The "reload 0 register set value + 1" and "reload 1 register set value + 1" respectively are effective as count values.

Stopping timer and count disable writing to enable bit occur at same time. (Stopping time is not synchronized with PWM output period.)

The F/F output waveform in PWM output mode is inverted (F/F output level changes from "L" to "H" or vice versa) when the counter starts counting and each time it underflows. The timer stops at the same time count is disabled by writing to the enable bit (and not in synchronism with PWM output period).

An interrupt request and DMA transfer request can be generated at even-numbered occurrences of underflow after the counter is enabled.

#### (2) Single-shot PWM output mode (without correction function)

In single-shot PWM output mode, the timer uses two reload registers to generate a waveform with a given duty cycle only once. During PWM output mode, the timer operates as a 16-bit timer.

When the timer is enabled after setting the initial values in the reload 0 and reload 1 registers, the counter is loaded with the reload 0 register value and starts counting down synchronously with the count clock. At the cycle after the first time the counter underflows, it is loaded with the value that "the reload 1 register -1" and continues counting. The counter stops when it underflows next time. The "reload 0 register set value + 1" and "reload 1 register set value + 1" respectively are effective as count values.

The timer can be stopped in software, in which case it stops at the same time count is disabled by writing to the enable bit (and not in synchronism with PWM output period).

The F/F output waveform in single-shot PWM output mode is inverted (F/F output level changes from "L" to "H" or vice versa) each time the counter underflows. (Unlike in PWM output mode, the F/F output is not inverted when the counter is enabled.)

An interrupt request and DMA transfer request can be generated when the counter underflows second time after being enabled.

#### (3) Delayed single-shot output mode

In delayed single-shot output mode, the timer generates a pulse in width of "reload register set value + 1" after a finite time equal to "counter set value + 1" only once and then stops.

When the timer is enabled after setting the counter and reload register, it starts counting down from the counter's set value synchronously with the count clock. At the cycle after the first time the counter underflows, it is loaded with the value that "the reload register -1" and continues counting down. The counter stops when it underflows next time.

The F/F output waveform in delayed single-shot output mode is inverted (F/F output level changes from "L" to "H" or vice versa) when the counter underflows first time and next, generating a single-shot pulse waveform in width of "reload register set value + 1" after a finite time equal to "first set value of counter + 1" only once.

An interrupt request and DMA transfer request can be generated when the counter underflows first time and next.

**(4) Single-shot output mode (without correction function)**

In single-shot output mode, the timer generates a pulse in width of "reload register set value + 1" only once and then stops.

When the timer is enabled after setting the reload register, the counter is loaded with the content of "the reload register - 1" and starts counting synchronously with the count clock at the next cycle. The counter counts down and when the minimum count is reached, stops upon underflow.

The F/F output waveform in single-shot output mode is inverted (F/F output level changes from "L" to "H" or vice versa) at startup and upon underflow, generating a single-shot pulse waveform in width of "reload register set value + 1" only once. An interrupt request and DMA transfer request can be generated when the counter underflows.

**(5) Continuous output mode (without correction function)**

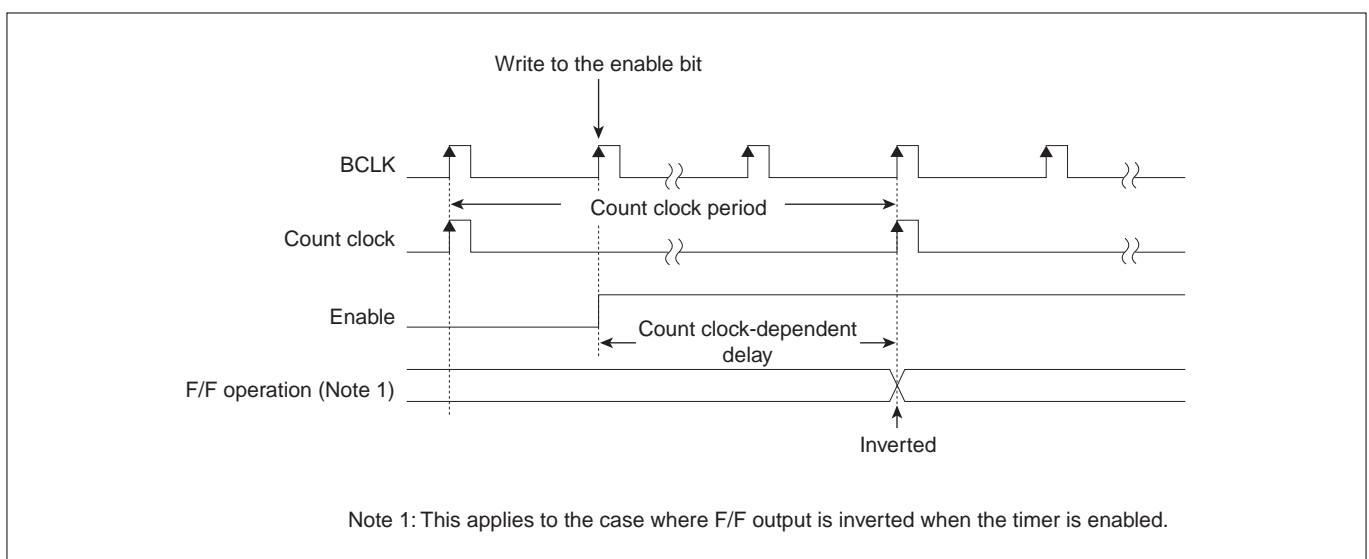
In continuous output mode, the timer counts down starting from the set value of the counter and when the counter underflows, it is loaded with the value that the reload register. Thereafter, this operation is repeated each time the counter underflows, thus generating inverted consecutive pulses in width of "reload register set value + 1."

When the timer is enabled after setting the counter and reload register, it starts counting down from the counter's set value synchronously with the count clock and when the minimum count is reached, generates an underflow. At the cycle after this underflow causes the counter to be loaded with the content of "the reload register - 1" and start counting over again at the next cycle. Thereafter, this operation is repeated each time an underflow occurs. To stop the counter, disable count by writing to the enable bit in software.

The F/F output waveform in continuous output mode is inverted (F/F output level changes from "L" to "H" or vice versa) at startup and upon underflow, generating a waveform of consecutive pulses until the timer stops counting. An interrupt request and DMA transfer request can be generated each time the counter underflows.

**<Count clock-dependent delay>**

- Because the timer operates synchronously with the count clock, up to one count clock-dependent delay is generated by the time when the timer actually starts operating after writing the enable bit. In operation mode where the F/F output is inverted when the timer is enabled, there is also a count clock-dependent delay before the F/F output is inverted.



**Figure 10.8.2 Count Clock Dependent Delay**

## 10.8.3 TOU Related Register Map

Shown below is a TOU related register map.

TOU Related Register Map (1/3)

Address	+0 address b0	b7	+1 address b8	b15	See pages
H'0080 0520	PWM Output 0 Disable Control Register GA (PO0DISGACR)		PWM Output 0 Disable Level Control Register GA (PO0LVGACR)		10-168 10-171
H'0080 0522	PWM Output 1 Disable Control Register GA (PO1DISGACR)		PWM Output 1 Disable Level Control Register GA (PO1LVGACR)		10-168 10-171
H'0080 0524	(Use inhibited area)				
H'0080 0526	PWMOFF 0 Function Enable Register (PWMOFF0EN)		PWMOFF 1 Function Enable Register (PWMOFF1EN)		10-173
H'0080 0780	PWM Output 0 Disable Control Register GB (PO0DISGBCR)		PWM Output 0 Disable Level Control Register GB (PO0LVGBCR)		10-168 10-171
H'0080 0782	PWM Output 1 Disable Control Register GB (PO1DISGBCR)		PWM Output 1 Disable Level Control Register GB (PO1LVGBCR)		10-169 10-171
H'0080 0790	TOU0_0 Counter (TOU00CTW)		(Upper) (TOU00CTH)		10-157
H'0080 0792	-----		(Lower) (TOU00CT)		10-159
H'0080 0794	TOU0_0 Reload Register (TOU00RLW)		TOU0_0 Reload 1 Register (TOU00RL1)		10-160 10-162
H'0080 0796	-----		TOU0_0 Reload 0 Register (TOU00RL0)		10-161
H'0080 0798	TOU0_1 Counter (TOU01CTW)		(Upper) (TOU01CTH)		10-157
H'0080 079A	-----		(Lower) (TOU01CT)		10-159
H'0080 079C	TOU0_1 Reload Register (TOU01RLW)		TOU0_1 Reload 1 Register (TOU01RL1)		10-160 10-162
H'0080 079E	-----		TOU0_1 Reload 0 Register (TOU01RL0)		10-161
H'0080 07A0	TOU0_2 Counter (TOU02CTW)		(Upper) (TOU02CTH)		10-157
H'0080 07A2	-----		(Lower) (TOU02CT)		10-159
H'0080 07A4	TOU0_2 Reload Register (TOU02RLW)		TOU0_2 Reload 1 Register (TOU02RL1)		10-160 10-162
H'0080 07A6	-----		TOU0_2 Reload 0 Register (TOU02RL0)		10-161
H'0080 07A8	TOU0_3 Counter (TOU03CTW)		(Upper) (TOU03CTH)		10-157
H'0080 07AA	-----		(Lower) (TOU03CT)		10-159
H'0080 07AC	TOU0_3 Reload Register (TOU03RLW)		TOU0_3 Reload 1 Register (TOU03RL1)		10-160 10-162
H'0080 07AE	-----		TOU0_3 Reload 0 Register (TOU03RL0)		10-161
H'0080 07B0	TOU0_4 Counter (TOU04CTW)		(Upper) (TOU04CTH)		10-157
H'0080 07B2	-----		(Lower) (TOU04CT)		10-159
H'0080 07B4	TOU0_4 Reload Register (TOU04RLW)		TOU0_4 Reload 1 Register (TOU04RL1)		10-160 10-162
H'0080 07B6	-----		TOU0_4 Reload 0 Register (TOU04RL0)		10-161

## TOU Related Register Map (2/3)

Address	+0 address		+1 address		See pages
	b0	b7 b8	b7 b8	b15	
H'0080 07B8	TOU0_5 Counter (TOU05CTW)		(Upper) (TOU05CTH)		10-157
H'0080 07BA	-----		(Lower) (TOU05CT)		10-159
H'0080 07BC	TOU0_5 Reload Register (TOU05RLW)		TOU0_5 Reload 1 Register (TOU05RL1)		10-160 10-162
H'0080 07BE	-----		TOU0_5 Reload 0 Register (TOU05RL0)		10-161
H'0080 07C0	TOU0_6 Counter (TOU06CTW)		(Upper) (TOU06CTH)		10-157
H'0080 07C2	-----		(Lower) (TOU06CT)		10-159
H'0080 07C4	TOU0_6 Reload Register (TOU06RLW)		TOU0_6 Reload 1 Register (TOU06RL1)		10-160 10-162
H'0080 07C6	-----		TOU0_6 Reload 0 Register (TOU06RL0)		10-161
H'0080 07C8	TOU0_7 Counter (TOU07CTW)		(Upper) (TOU07CTH)		10-157
H'0080 07CA	-----		(Lower) (TOU07CT)		10-159
H'0080 07CC	TOU0_7 Reload Register (TOU07RLW)		TOU0_7 Reload 1 Register (TOU07RL1)		10-160 10-162
H'0080 07CE	-----		TOU0_7 Reload 0 Register (TOU07RL0)		10-161
H'0080 07D4	Shorting Prevention Function F/F21–26 Protect Register (SHFF2126P)				10-155
H'0080 07D6	Shorting Prevention Function F/F21–26 Data Register (SHFF2126D)				10-156
H'0080 07D8	TOU0 Control Register 1 (TOU0CR1)				10-153
H'0080 07DA	TOU0 Control Register 0 (TOU0CR0)				10-153
H'0080 07DC	(Use inhibited area)		TOU0 Enable Protect Register (TOU0PRO)		10-163
H'0080 07DE	(Use inhibited area)		TOU0 Count Enable Register (TOU0CEN)		10-164
H'0080 07E0	PWMOFF0 Input Processing Control Register (PWMOFF0CR)				10-166
H'0080 0B90	TOU1_0 Counter (TOU10CTW)		(Upper) (TOU10CTH)		10-157
H'0080 0B92	-----		(Lower) (TOU10CT)		10-159
H'0080 0B94	TOU1_0 Reload Register (TOU10RLW)		TOU1_0 Reload 1 Register (TOU10RL1)		10-160 10-162
H'0080 0B96	-----		TOU1_0 Reload 0 Register (TOU10RL0)		10-161
H'0080 0B98	TOU1_1 Counter (TOU11CTW)		(Upper) (TOU11CTH)		10-157
H'0080 0B9A	-----		(Lower) (TOU11CT)		10-159
H'0080 0B9C	TOU1_1 Reload Register (TOU11RLW)		TOU1_1 Reload 1 Register (TOU11RL1)		10-160 10-162
H'0080 0B9E	-----		TOU1_1 Reload 0 Register (TOU11RL0)		10-161

TOU Related Register Map (3/3)

Address	+0 address		+1 address		See pages
	b0	b7 b8	b7 b8	b15	
H'0080 0BA0	TOU1_2 Counter (TOU12CTW)		(Upper) (TOU12CTH)		10-157
H'0080 0BA2			(Lower) (TOU12CT)		10-159
H'0080 0BA4	TOU1_2 Reload Register (TOU12RLW)		TOU1_2 Reload 1 Register (TOU12RL1)		10-160 10-162
H'0080 0BA6			TOU1_2 Reload 0 Register (TOU12RL0)		10-161
H'0080 0BA8	TOU1_3 Counter (TOU13CTW)		(Upper) (TOU13CTH)		10-157
H'0080 0BAA			(Lower) (TOU13CT)		10-159
H'0080 0BAC	TOU1_3 Reload Register (TOU13RLW)		TOU1_3 Reload 1 Register (TOU13RL1)		10-160 10-162
H'0080 0BAE			TOU1_3 Reload 0 Register (TOU13RL0)		10-161
H'0080 0BB0	TOU1_4 Counter (TOU14CTW)		(Upper) (TOU14CTH)		10-157
H'0080 0BB2			(Lower) (TOU14CT)		10-159
H'0080 0BB4	TOU1_4 Reload Register (TOU14RLW)		TOU1_4 Reload 1 Register (TOU14RL1)		10-160 10-162
H'0080 0BB6			TOU1_4 Reload 0 Register (TOU14RL0)		10-161
H'0080 0BB8	TOU1_5 Counter (TOU15CTW)		(Upper) (TOU15CTH)		10-157
H'0080 0BBA			(Lower) (TOU15CT)		10-159
H'0080 0BBC	TOU1_5 Reload Register (TOU15RLW)		TOU1_5 Reload 1 Register (TOU15RL1)		10-160 10-162
H'0080 0BBE			TOU1_5 Reload 0 Register (TOU15RL0)		10-161
H'0080 0BC0	TOU1_6 Counter (TOU16CTW)		(Upper) (TOU16CTH)		10-157
H'0080 0BC2			(Lower) (TOU16CT)		10-159
H'0080 0BC4	TOU1_6 Reload Register (TOU16RLW)		TOU1_6 Reload 1 Register (TOU16RL1)		10-160 10-162
H'0080 0BC6			TOU1_6 Reload 0 Register (TOU16RL0)		10-161
H'0080 0BC8	TOU1_7 Counter (TOU17CTW)		(Upper) (TOU17CTH)		10-157
H'0080 0BCA			(Lower) (TOU17CT)		10-159
H'0080 0BCC	TOU1_7 Reload Register (TOU17RLW)		TOU1_7 Reload 1 Register (TOU17RL1)		10-160 10-162
H'0080 0BCE			TOU1_7 Reload 0 Register (TOU17RL0)		10-161
H'0080 0BD4	Shorting Prevention Function F/F29–34 Protect Register (SHFF2934P)				10-155
H'0080 0BD6	Shorting Prevention Function F/F29–34 Data Register (SHFF2934D)				10-156
H'0080 0BD8	TOU1 Control Register 1 (TOU1CR1)				10-154
H'0080 0BDA	TOU1 Control Register 0 (TOU1CR0)				10-154
H'0080 0BDC	(Use inhibited area)		TOU1 Enable Protect Register (TOU1PRO)		10-163
H'0080 0BDE	(Use inhibited area)		TOU1 Count Enable Register (TOU1CEN)		10-164
H'0080 0BE0	PWMOFF1 Input Processing Control Register (PWMOFF1CR)				10-166



## 10.8.4 TOU Control Registers

TOU0 Control Register 0 (TOU0CR0)

&lt;Address: H'0080 07DA&gt;

b0	1	2	3	4	5	6	7	8	9	10	11	12	13	14	b15
TOU00M0	TOU01M0	TOU02M0	TOU03M0	TOU04M0	TOU05M0	TOU06M0	TOU07M0								
0	0	0	0	0	0	0	0	0	0	0	0	0	0	0	0

&lt;Upon exiting reset: H'0000&gt;

b	Bit Name	Function	R	W
0, 1	TOU00M0 (TOU0_0 operation mode select 0 bit)	00: Single-shot output mode	R	W
2, 3	TOU01M0 (TOU0_1 operation mode select 0 bit)	01: Single-shot PWM output mode		
4, 5	TOU02M0 (TOU0_2 operation mode select 0 bit)	or delayed single-shot output mode (Note 1)		
6, 7	TOU03M0 (TOU0_3 operation mode select 0 bit)	10: Continuous output mode		
8, 9	TOU04M0 (TOU0_4 operation mode select 0 bit)	11: PWM output mode		
10, 11	TOU05M0 (TOU0_5 operation mode select 0 bit)			
12, 13	TOU06M0 (TOU0_6 operation mode select 0 bit)			
14, 15	TOU07M0 (TOU0_7 operation mode select 0 bit)			

Note 1: Use TOU0 Control Register 1 to select between these two modes.

Notes: • This register must always be accessed in halfwords.

- Operation mode can only be set or changed while the counter is inactive.

TOU0 Control Register 1 (TOU0CR1)

&lt;Address: H'0080 07D8&gt;

b0	1	2	3	4	5	6	7	8	9	10	11	12	13	14	b15
TOU0CKS	PRS3CKS						TOU0SHEN	TOU00M1	TOU01M1	TOU02M1	TOU03M1	TOU04M1	TOU05M1	TOU06M1	TOU07M1
0	0	0	0	0	0	0	0	0	0	0	0	0	0	0	0

&lt;Upon exiting reset: H'0000&gt;

b	Bit Name	Function	R	W
0	TOU0CKS TOU0 clock source select bit	0: Use prescaler 3 1: Use external clock (TIN24)	R	W
1	PRS3CKS Prescaler 3 supplied clock select bit	0: BCLK/4 1: BCLK	R	W
2–6	No function assigned. Fix to "0."		0	0
7	TOU0SHEN TOU0 shorting prevention function enable bit	0: Disable shorting prevention function 1: Enable shorting prevention function	R	W
8	TOU00M1 (TOU0_0 operation mode select 1 bit)	0: Single-shot PWM output mode	R	W
9	TOU01M1 (TOU0_1 operation mode select 1 bit)	1: Delayed single-shot output mode		
10	TOU02M1 (TOU0_2 operation mode select 1 bit)			
11	TOU03M1 (TOU0_3 operation mode select 1 bit)			
12	TOU04M1 (TOU0_4 operation mode select 1 bit)			
13	TOU05M1 (TOU0_5 operation mode select 1 bit)			
14	TOU06M1 (TOU0_6 operation mode select 1 bit)			
15	TOU07M1 (TOU0_7 operation mode select 1 bit)			

Notes: • This register must always be accessed in halfwords.

- Operation mode and the short prevention function can only be set or changed while the counter is inactive.

TOU0 Control Registers 0 and 1 are used to select operation modes of TOU0\_0–7.

To select prescaler 3 as the clock source for TOU0, make sure the TID0 Control &amp; Prescaler 3 Enable Register's prescaler 3 enable bit is set to "1." For details, see Section 10.7.3, "TID Control &amp; Prescaler Enable Registers."

Note: • Before setting up or modifying the TOU control register, be sure to stop the relevant timer by writing "0" to its count enable bit.

TOU1 Control Register 0 (TOU1CR0)

&lt;Address: H'0080 0BDA&gt;

b0	1	2	3	4	5	6	7	8	9	10	11	12	13	14	b15
TOU10M0		TOU11M0		TOU12M0		TOU13M0		TOU14M0		TOU15M0		TOU16M0		TOU17M0	
0	0	0	0	0	0	0	0	0	0	0	0	0	0	0	0

&lt;Upon exiting reset: H'0000&gt;

b	Bit Name	Function	R	W
0, 1	TOU10M0 (TOU1_0 operation mode select 0 bit)	00: Single-shot output mode	R	W
2, 3	TOU11M0 (TOU1_1 operation mode select 0 bit)	01: Single-shot PWM output mode		
4, 5	TOU12M0 (TOU1_2 operation mode select 0 bit)	or delayed single-shot output mode (Note 1)		
6, 7	TOU13M0 (TOU1_3 operation mode select 0 bit)	10: Continuous output mode		
8, 9	TOU14M0 (TOU1_4 operation mode select 0 bit)	11: PWM output mode		
10, 11	TOU15M0 (TOU1_5 operation mode select 0 bit)			
12, 13	TOU16M0 (TOU1_6 operation mode select 0 bit)			
14, 15	TOU17M0 (TOU1_7 operation mode select 0 bit)			

Note 1: Use TOU1 Control Register 1 to select between these two modes.

Notes: • This register must always be accessed in halfwords.

- Operation mode can only be set or changed while the counter is inactive.

TOU1 Control Register 1 (TOU1CR1)

&lt;Address: H'0080 0BD8&gt;

b0	1	2	3	4	5	6	7	8	9	10	11	12	13	14	b15	
TOU1 CKS	PRS4 CKS						TOU1 SHEN	TOU10 M1	TOU11 M1	TOU12 M1	TOU13 M1	TOU14 M1	TOU15 M1	TOU16 M1	TOU17 M1	
0	0	0	0	0	0	0	0	0	0	0	0	0	0	0	0	

&lt;Upon exiting reset: H'0000&gt;

b	Bit Name	Function	R	W
0	TOU1CKS TOU1 clock source select bit	0: Use prescaler 4 1: Use external clock (TIN26)	R	W
1	PRS4CKS Prescaler 4 supplied clock select bit	0: BCLK/4 1: BCLK	R	W
2–6	No function assigned. Fix to "0."		0	0
7	TOU1SHEN TOU1 shorting prevention function enable bit	0: Disable shorting prevention function 1: Enable shorting prevention function	R	W
8	TOU10M1 (TOU1_0 operation mode select 1 bit)	0: Single-shot PWM output mode	R	W
9	TOU11M1 (TOU1_1 operation mode select 1 bit)	1: Delayed single-shot output mode		
10	TOU12M1 (TOU1_2 operation mode select 1 bit)			
11	TOU13M1 (TOU1_3 operation mode select 1 bit)			
12	TOU14M1 (TOU1_4 operation mode select 1 bit)			
13	TOU15M1 (TOU1_5 operation mode select 1 bit)			
14	TOU16M1 (TOU1_6 operation mode select 1 bit)			
15	TOU17M1 (TOU1_7 operation mode select 1 bit)			

Note 1: This register must always be accessed in halfwords.

Note: • Operation mode and shorting prevention function can only be set or changed while the counter is inactive.

TOU1 Control Registers 0 and 1 are used to select operation modes of TOU1\_0–7.

To select prescaler 4 as the clock source for TOU1, make sure the TID1 Control &amp; Prescaler 4 Enable Register's prescaler 4 enable bit is set to "1." For details, see Section 10.7.3, "TID Control &amp; Prescaler Enable Registers."

Note: • Before setting up or modifying the TOU control register, be sure to stop the relevant timer by writing "0" to its count enable bit.

## 10.8.5 Shorting Prevention Function Registers

Shorting Prevention Function F/F21-26 Protect Register (SHFF2126P)

&lt;Address: H'0080 07D4&gt;

b0	1	2	3	4	5	6	b7
SHFP21	SHFP22	SHFP23	SHFP24	SHFP25	SHFP26	0	0
0	0	0	0	0	0	0	0

&lt;Upon exiting reset: H'00&gt;

b	Bit Name	Function	R	W
0	SHFP21 Shorting prevention function F/F21 protect bit	0: Enable write to shorting prevention function F/F output bit 1: Disable write to shorting prevention function F/F output bit	R	W
1	SHFP22 Shorting prevention function F/F22 protect bit			
2	SHFP23 Shorting prevention function F/F23 protect bit			
3	SHFP24 Shorting prevention function F/F24 protect bit			
4	SHFP25 Shorting prevention function F/F25 protect bit			
5	SHFP26 Shorting prevention function F/F26 protect bit			
6, 7	No function assigned. Fix to "0."		0	0

Shorting Prevention Function F/F29-34 Protect Register (SHFF2934P)

&lt;Address: H'0080 0BD4&gt;

b0	1	2	3	4	5	6	b7
SHFP29	SHFP30	SHFP31	SHFP32	SHFP33	SHFP34	0	0
0	0	0	0	0	0	0	0

&lt;Upon exiting reset: H'00&gt;

b	Bit Name	Function	R	W
0	SHFP29 Shorting prevention function F/F29 protect bit	0: Enable write to shorting prevention function F/F output bit 1: Disable write to shorting prevention function F/F output bit	R	W
1	SHFP30 Shorting prevention function F/F30 protect bit			
2	SHFP31 Shorting prevention function F/F31 protect bit			
3	SHFP32 Shorting prevention function F/F32 protect bit			
4	SHFP33 Shorting prevention function F/F33 protect bit			
5	SHFP34 Shorting prevention function F/F34 protect bit			
6, 7	No function assigned. Fix to "0."		0	0

These registers control write to each shorting prevention function F/F (flip-flop) by enabling or disabling. If write to any F/F is disabled, writing to the shorting prevention F/F data register has no effect.

Shorting Prevention Function F/F21-26 Data Register (SHFF2126D)

&lt;Address: H'0080 07D6&gt;

b0	1	2	3	4	5	6	b7
SHFD21	SHFD22	SHFD23	SHFD24	SHFD25	SHFD26	0	0
0	0	0	0	0	0	0	0

&lt;Upon exiting reset: H'00&gt;

b	Bit Name	Function	R	W
0	SHFD21 Shorting prevention function F/F21 data bit	0: Shorting prevention function F/F output data = 0 1: Shorting prevention function F/F output data = 1	R	W
1	SHFD22 Shorting prevention function F/F22 data bit			
2	SHFD23 Shorting prevention function F/F23 data bit			
3	SHFD24 Shorting prevention function F/F24 data bit			
4	SHFD25 Shorting prevention function F/F25 data bit			
5	SHFD26 Shorting prevention function F/F26 data bit			
6, 7	No function assigned. Fix to "0."		0	0

Shorting Prevention Function F/F29–34 Data Register (SHFF2934D)

&lt;Address: H'0080 0BD6&gt;

b0	1	2	3	4	5	6	b7
SHFD29	SHFD30	SHFD31	SHFD32	SHFD33	SHFD34	0	0
0	0	0	0	0	0	0	0

&lt;Upon exiting reset: H'00&gt;

b	Bit Name	Function	R	W
0	SHFD29 Shorting prevention function F/F29 data bit	0: Shorting prevention function F/F output data = 0 1: Shorting prevention function F/F output data = 1	R	W
1	SHFD30 Shorting prevention function F/F30 data bit			
2	SHFD31 Shorting prevention function F/F31 data bit			
3	SHFD32 Shorting prevention function F/F32 data bit			
4	SHFD33 Shorting prevention function F/F33 data bit			
5	SHFD34 Shorting prevention function F/F34 data bit			
6, 7	No function assigned. Fix to "0."		0	0

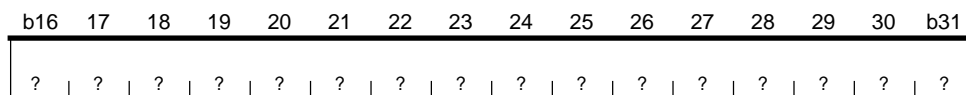
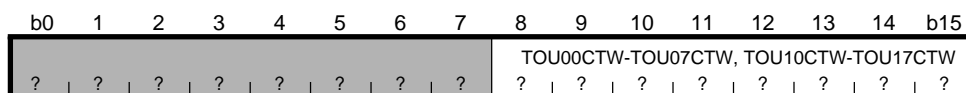
These registers are used to set output in each shorting prevention function F/F (flip-flop). The F/F data register can only be operated on when the F/F protect register described earlier is enabled for write.

#### 10.8.6 TOU Counters

The TOU counters are functionally different depending on the timer's operation mode.

##### (1) TOU counters during single-shot output, delayed single-shot output and continuous output modes

TOU0_0 Counter (TOU00CTW)	<Address: H'0080 0790>
TOU0_1 Counter (TOU01CTW)	<Address: H'0080 0798>
TOU0_2 Counter (TOU02CTW)	<Address: H'0080 07A0>
TOU0_3 Counter (TOU03CTW)	<Address: H'0080 07A8>
TOU0_4 Counter (TOU04CTW)	<Address: H'0080 07B0>
TOU0_5 Counter (TOU05CTW)	<Address: H'0080 07B8>
TOU0_6 Counter (TOU06CTW)	<Address: H'0080 07C0>
TOU0_7 Counter (TOU07CTW)	<Address: H'0080 07C8>
TOU1_0 Counter (TOU10CTW)	<Address: H'0080 0B90>
TOU1_1 Counter (TOU11CTW)	<Address: H'0080 0B98>
TOU1_2 Counter (TOU12CTW)	<Address: H'0080 0BA0>
TOU1_3 Counter (TOU13CTW)	<Address: H'0080 0BA8>
TOU1_4 Counter (TOU14CTW)	<Address: H'0080 0BB0>
TOU1_5 Counter (TOU15CTW)	<Address: H'0080 0BB8>
TOU1_6 Counter (TOU16CTW)	<Address: H'0080 0BC0>
TOU1_7 Counter (TOU17CTW)	<Address: H'0080 0BC8>



<Upon exiting reset: Undefined>

b	Bit Name	Function	R	W
0-7	No function assigned. Fix to "0"		0	0
8-31	TOU00CTW-TOU07CTW, TOU10CTW-TOU17CTW	24-bit counter value	R	W

Note: • These registers must always be accessed wordwise (in 32 bits) beginning with the word boundary (low-order address B'00).

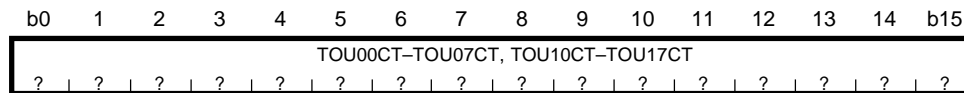
The TOU counters operate as a 24-bit down-counter when in single-shot output, delayed single-shot output or continuous output mode. After the timer is enabled (by writing to the enable bit in software or upon occurrence of the event selected by the TOU enable source select bit), the counter starts counting synchronously with the count clock. Bits 8–15 and bits 16–31 are the 8 high-order and the 16 low-order bits of the counter, respectively. Bits 0–7 are ignored.

When writing to the counter separately in high and low-order bits, rewrite the 8 high-order bits first and then the 16 low-order bits. The 8 high-order bits become effective when the 16 low-order bits are rewritten. If the counter is rewritten in the reverse order beginning with the 16 low-order bits, the value of the 8 high-order bits is not reflected until the next time the 16 low-order bits are rewritten. If the 8 high-order bits are read before the CPU has finished rewriting the 16 low-order bits after rewriting the 8 high-order bits. The read value shows the previous data (when not counting) or the current count of the previous data (when count is in progress), and not the new rewritten data. If the counter is written to in 32-bit units, it is rewritten successively in order of the 8 high-order bits and then the 16 low-order bits automatically.

During PWM output or single-shot PWM output mode, the TOU counters operate as a 16-bit down-counter where only the 16 low-order bits are effective. For details, see Section 10.8.6, Paragraph (2), “TOU counters during PWM output and single-shot PWM output modes.”

#### (2) TOU counters during PWM output and single-shot PWM output modes

TOU0_0 Counter (TOU00CT)	<Address: H'0080 0792>
TOU0_1 Counter (TOU01CT)	<Address: H'0080 079A>
TOU0_2 Counter (TOU02CT)	<Address: H'0080 07A2>
TOU0_3 Counter (TOU03CT)	<Address: H'0080 07AA>
TOU0_4 Counter (TOU04CT)	<Address: H'0080 07B2>
TOU0_5 Counter (TOU05CT)	<Address: H'0080 07BA>
TOU0_6 Counter (TOU06CT)	<Address: H'0080 07C2>
TOU0_7 Counter (TOU07CT)	<Address: H'0080 07CA>
TOU1_0 Counter (TOU10CT)	<Address: H'0080 0B92>
TOU1_1 Counter (TOU11CT)	<Address: H'0080 0B9A>
TOU1_2 Counter (TOU12CT)	<Address: H'0080 0BA2>
TOU1_3 Counter (TOU13CT)	<Address: H'0080 0BAA>
TOU1_4 Counter (TOU14CT)	<Address: H'0080 0BB2>
TOU1_5 Counter (TOU15CT)	<Address: H'0080 0BBA>
TOU1_6 Counter (TOU16CT)	<Address: H'0080 0BC2>
TOU1_7 Counter (TOU17CT)	<Address: H'0080 0BCA>



<Upon exiting reset: Undefined>

b	Bit Name	Function	R	W
0-15	TOU00CT-TOU07CT, TOU10CT-TOU17CT	16-bit counter value	R	W

Note: • These registers must always be accessed in halfwords.

The TOU counters operate as a 16-bit down-counter when in PWM output or single-shot PWM output mode. After the timer is enabled (by writing to the enable bit in software or upon occurrence of the event selected by the TOU enable source select bit), the counter starts counting synchronously with the count clock.

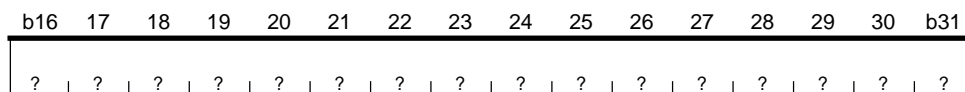
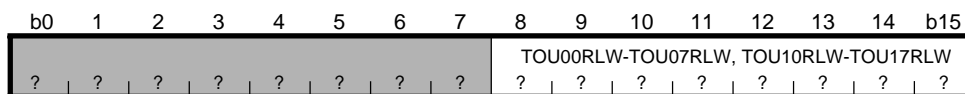
During single-shot output, delayed single-shot output and continuous output modes, the TOU counters operate as a 24-bit down-counter, with the 8 high-order bits added. For details, see Section 10.8.6, Paragraph (1), "TOU counters during single-shot output, delayed single-shot output and continuous output modes."

### 10.8.7 TOU Reload Registers

The TOU reload registers are used to load data into the TOU counters. These registers are functionally different depending on the timer's operation mode.

#### (1) TOU reload registers during single-shot output, delayed single-shot output and continuous output modes

TOU0_0 Reload Register (TOU00RLW)	<Address: H'0080 0794>
TOU0_1 Reload Register (TOU01RLW)	<Address: H'0080 079C>
TOU0_2 Reload Register (TOU02RLW)	<Address: H'0080 07A4>
TOU0_3 Reload Register (TOU03RLW)	<Address: H'0080 07AC>
TOU0_4 Reload Register (TOU04RLW)	<Address: H'0080 07B4>
TOU0_5 Reload Register (TOU05RLW)	<Address: H'0080 07BC>
TOU0_6 Reload Register (TOU06RLW)	<Address: H'0080 07C4>
TOU0_7 Reload Register (TOU07RLW)	<Address: H'0080 07CC>
TOU1_0 Reload Register (TOU10RLW)	<Address: H'0080 0B94>
TOU1_1 Reload Register (TOU11RLW)	<Address: H'0080 0B9C>
TOU1_2 Reload Register (TOU12RLW)	<Address: H'0080 0BA4>
TOU1_3 Reload Register (TOU13RLW)	<Address: H'0080 0BAC>
TOU1_4 Reload Register (TOU14RLW)	<Address: H'0080 0BB4>
TOU1_5 Reload Register (TOU15RLW)	<Address: H'0080 0BBC>
TOU1_6 Reload Register (TOU16RLW)	<Address: H'0080 0BC4>
TOU1_7 Reload Register (TOU17RLW)	<Address: H'0080 0BCC>



<Upon exiting reset: Undefined>

b	Bit Name	Function	R	W
0-7	No function assigned. Fix to "0."		0	0
8-31	TOU00RLW-TOU07RLW, TOU10RLW-TOU17RLW	24-bit reload register value	R	W

Note: • These registers must always be accessed wordwise (in 32 bits) beginning with the word boundary (low-order address B'00).

During single-shot output, delayed single-shot output and continuous output modes, TOU operates as a 24-bit timer. The value set in the 24 low-order bits of the reload register is loaded into the counter. Bits 8-15 and bits 16-31 are the 8 high-order and the 16 low-order bits of the counter, respectively. Bits 0-7 are ignored. The content of "the reload register -1" is loaded into the counter synchronously with the count clock at the following timing:

- At the next cycle when the counter is enabled in single-shot output mode
- At the next cycle when the counter has underflowed in delayed single-shot output or continuous output mode

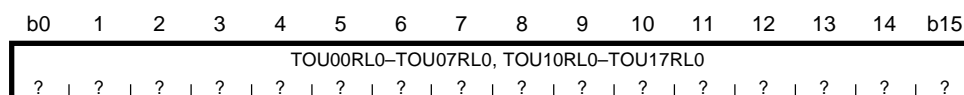
Simply because data is written to the reload register does not mean that the data is loaded into the counter. The counter is loaded with data in only the above cases.

During PWM output and single-shot PWM output modes, the TOU reload register operates as 16-bit reload 0 and reload 1 registers. For details, see Section 10.8.7, Paragraph (2), "TOU reload registers during PWM output and single-shot PWM output modes."



**(2) TOU reload registers during PWM output and single-shot PWM output modes**

TOU0_0 Reload 0 Register (TOU00RL0)	<Address: H'0080 0796>
TOU0_1 Reload 0 Register (TOU01RL0)	<Address: H'0080 079E>
TOU0_2 Reload 0 Register (TOU02RL0)	<Address: H'0080 07A6>
TOU0_3 Reload 0 Register (TOU03RL0)	<Address: H'0080 07AE>
TOU0_4 Reload 0 Register (TOU04RL0)	<Address: H'0080 07B6>
TOU0_5 Reload 0 Register (TOU05RL0)	<Address: H'0080 07BE>
TOU0_6 Reload 0 Register (TOU06RL0)	<Address: H'0080 07C6>
TOU0_7 Reload 0 Register (TOU07RL0)	<Address: H'0080 07CE>
TOU1_0 Reload 0 Register (TOU10RL0)	<Address: H'0080 0B96>
TOU1_1 Reload 0 Register (TOU11RL0)	<Address: H'0080 0B9E>
TOU1_2 Reload 0 Register (TOU12RL0)	<Address: H'0080 0BA6>
TOU1_3 Reload 0 Register (TOU13RL0)	<Address: H'0080 0BAE>
TOU1_4 Reload 0 Register (TOU14RL0)	<Address: H'0080 0BB6>
TOU1_5 Reload 0 Register (TOU15RL0)	<Address: H'0080 0BBE>
TOU1_6 Reload 0 Register (TOU16RL0)	<Address: H'0080 0BC6>
TOU1_7 Reload 0 Register (TOU17RL0)	<Address: H'0080 0BCE>



&lt;Upon exiting reset: Undefined&gt;

b	Bit Name	Function	R	W
0-15	TOU00RL0-TOU07RL0, TOU10RL0-TOU17RL0	16-bit reload register value	R	W

Note: • These registers must always be accessed in halfwords.

During PWM output and single-shot PWM output modes, TOU operates as a 16-bit timer. Use the reload 0 register to set the 16-bit value to be loaded into the counter when it is enabled.

The content of "the reload 0 register -1" is loaded into the counter synchronously with the count clock at the following timing:

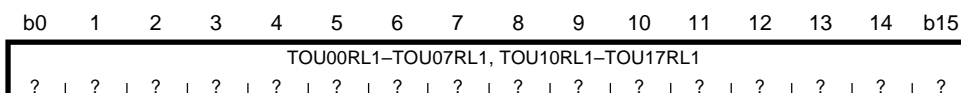
- At the next cycle when the counter is enabled
- At the next cycle when the count value set in the reload 1 register has underflowed in PWM output mode

Simply because data is written to the reload register does not mean that the data is loaded into the counter. The counter is loaded with data in only the above cases.

If the value "H'FFFF" is set in the reload register, F/F output will not be inverted, making it possible to produce a 0% or 100% duty-cycle PWM output. For details, see Section 10.8.19, "0% or 100% Duty-Cycle Wave Output during PWM Output and Single-shot PWM Output Modes."

During single-shot output, delayed single-shot output and continuous output modes, the reload 0 and reload 1 registers are combined for use as a 24-bit reload register. For details, see Section 10.8.7, Paragraph (1), "TOU reload registers during single-shot output, delayed single-shot output and continuous output modes."

TOU0_0 Reload 1 Register (TOU00RL1)	<Address: H'0080 0794>
TOU0_1 Reload 1 Register (TOU01RL1)	<Address: H'0080 079C>
TOU0_2 Reload 1 Register (TOU02RL1)	<Address: H'0080 07A4>
TOU0_3 Reload 1 Register (TOU03RL1)	<Address: H'0080 07AC>
TOU0_4 Reload 1 Register (TOU04RL1)	<Address: H'0080 07B4>
TOU0_5 Reload 1 Register (TOU05RL1)	<Address: H'0080 07BC>
TOU0_6 Reload 1 Register (TOU06RL1)	<Address: H'0080 07C4>
TOU0_7 Reload 1 Register (TOU07RL1)	<Address: H'0080 07CC>
TOU1_0 Reload 1 Register (TOU10RL1)	<Address: H'0080 0B94>
TOU1_1 Reload 1 Register (TOU11RL1)	<Address: H'0080 0B9C>
TOU1_2 Reload 1 Register (TOU12RL1)	<Address: H'0080 0BA4>
TOU1_3 Reload 1 Register (TOU13RL1)	<Address: H'0080 0BAC>
TOU1_4 Reload 1 Register (TOU14RL1)	<Address: H'0080 0BB4>
TOU1_5 Reload 1 Register (TOU15RL1)	<Address: H'0080 0BBC>
TOU1_6 Reload 1 Register (TOU16RL1)	<Address: H'0080 0BC4>
TOU1_7 Reload 1 Register (TOU17RL1)	<Address: H'0080 0BCC>



<Upon exiting reset: Undefined>

b	Bit Name	Function	R	W
0–15	TOU00RL1–TOU07RL1, TOU10RL1–TOU17RL1	16-bit reload register value	R	W

Note: • These registers must always be accessed in halfwords.

During PWM output and single-shot PWM output modes, TOU operates as a 16-bit timer. Use the reload 1 register to set the 16-bit value to be loaded into the counter when the count value set in the reload 1 register has underflowed.

The content of "the reload 1 register -1" is loaded into the counter synchronously with the count clock at the following timing:

- At the next cycle when the count value set in the reload 0 register has underflowed in PWM output mode

Simply because data is written to the reload register does not mean that the data is loaded into the counter. The counter is loaded with data in only the above cases.

If the value "H'FFFF" is set in the reload register, F/F output will not be inverted, making it possible to produce a 0% or 100% duty-cycle PWM output. For details, see Section 10.8.19, "0% or 100% Duty-Cycle Wave Output during PWM Output and Single-shot PWM Output Modes."

During single-shot output, delayed single-shot output and continuous output modes, the reload 0 and reload 1 registers are combined for use as a 24-bit reload register. For details, see Section 10.8.7, Paragraph (1), "TOU reload registers during single-shot output, delayed single-shot output and continuous output modes."

## 10.8.8 TOU Enable Protect Registers

TOU0 Enable Protect Register (TOU0PRO)

&lt;Address: H'0080 07DD&gt;

TOU1 Enable Protect Register (TOU1PRO)

&lt;Address: H'0080 0BDD&gt;

b8	9	10	11	12	13	14	b15
TOUn0PRO	TOUn1PRO	TOUn2PRO	TOUn3PRO	TOUn4PRO	TOUn5PRO	TOUn6PRO	TOUn7PRO
0	0	0	0	0	0	0	0

&lt;Upon exiting reset: H'00&gt;

b	Bit Name	Function	R	W
8	TOUn0PRO TOUn_0 enable protect bit	0: Enable rewrite 1: Disable rewrite	R	W
9	TOUn1PRO TOUn_1 enable protect bit			
10	TOUn2PRO TOUn_2 enable protect bit			
11	TOUn3PRO TOUn_3 enable protect bit			
12	TOUn4PRO TOUn_4 enable protect bit			
13	TOUn5PRO TOUn_5 enable protect bit			
14	TOUn6PRO TOUn_6 enable protect bit			
15	TOUn7PRO TOUn_7 enable protect bit			

The TOU enable protect registers control rewriting of the TOU count enable bit described in Section 10.8.9, “TOU Count Enable Registers,” by enabling or disabling rewrite.

## 10.8.9 TOU Count Enable Registers

TOU0 Count Enable Register (TOU0CEN)

&lt;Address: H'0080 07DF&gt;

TOU1 Count Enable Register (TOU1CEN)

&lt;Address: H'0080 0BDF&gt;

b8	9	10	11	12	13	14	b15
TOUn0CEN	TOUn1CEN	TOUn2CEN	TOUn3CEN	TOUn4CEN	TOUn5CEN	TOUn6CEN	TOUn7CEN
0	0	0	0	0	0	0	0

&lt;Upon exiting reset: H'00&gt;

b	Bit Name	Function	R	W
8	TOUn0CEN TOUn_0 count enable bit	0: Stop count 1: Enable count	R	W
9	TOUn1CEN TOUn_1 count enable bit			
10	TOUn2CEN TOUn_2 count enable bit			
11	TOUn3CEN TOUn_3 count enable bit			
12	TOUn4CEN TOUn_4 count enable bit			
13	TOUn5CEN TOUn_5 count enable bit			
14	TOUn6CEN TOUn_6 count enable bit			
15	TOUn7CEN TOUn_7 count enable bit			

The TOU count enable registers control operation of the TOU counters. To enable any TOU counter in software, enable its corresponding enable protect bit for rewrite and set the count enable bit by writing "1." To stop any TOU counter, enable its corresponding enable protect bit for rewrite and reset the count enable bit by writing "0."

In single-shot output, single-shot PWM output or delayed single-shot output mode, when the counter stops due to occurrence of an underflow, the count enable bit is automatically reset to "0." Therefore, the TOU count enable register when accessed for read serves as a status register indicating whether the counter is operating or idle.

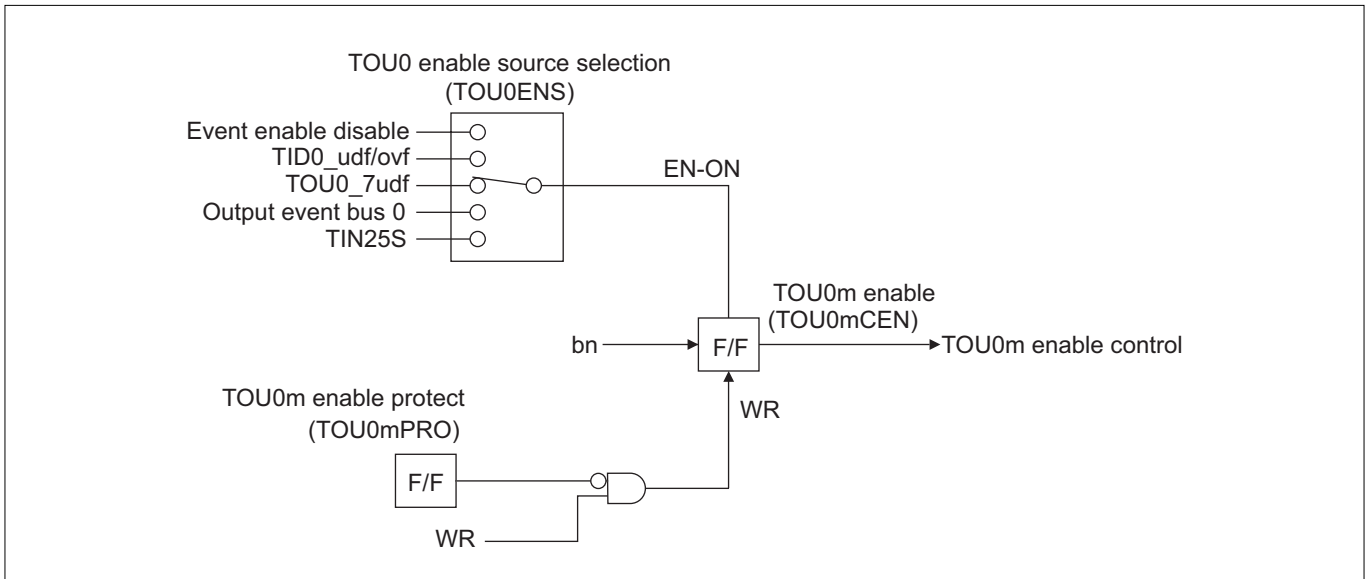


Figure 10.8.3 Configuration of the TOU0 Enable Circuit

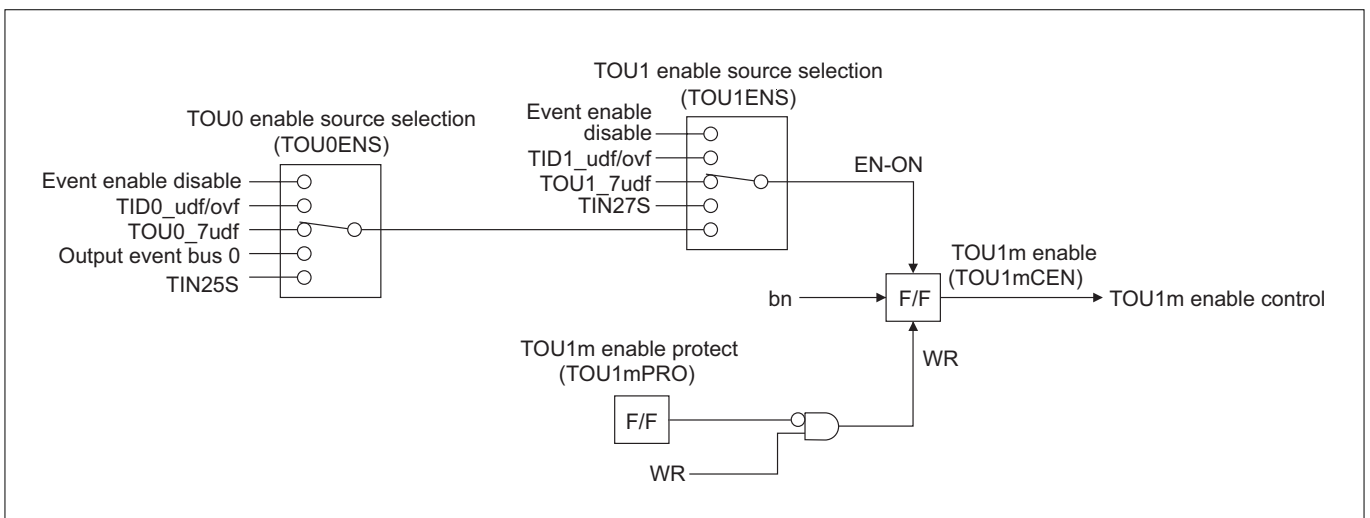


Figure 10.8.4 Configuration of the TOU1 Enable Circuit

## 10.8.10 PWMOFF Input Processing Control Registers

PWMOFF0 Input Processing Control Register (PWMOFF0CR)

&lt;Address: H'0080 07E0&gt;

b0	1	2	3	4	5	6	b7
0	0	0	0	PWMOFF0SP 0	0	PWMOFF0S 0	0

&lt;Upon exiting reset: H'00&gt;

b	Bit Name	Function	R	W
0–3	No function assigned. Fix to "0."		0	0
4	PWMOFF0SP PWMOFF0S write control bit	–	0	W
5–7	PWMOFF0S PWMOFF0 input processing control bit	000: Input has no effect 001: Rising edge 010: Falling edge 011: Both edges 10X: "L" level 11X: "H" level	R	W

PWMOFF1 Input Processing Control Register (PWMOFF1CR)

&lt;Address: H'0080 0BE0&gt;

b0	1	2	3	4	5	6	b7
0	0	0	0	PWMOFF1SP 0	0	PWMOFF1S 0	0

&lt;Upon exiting reset: H'00&gt;

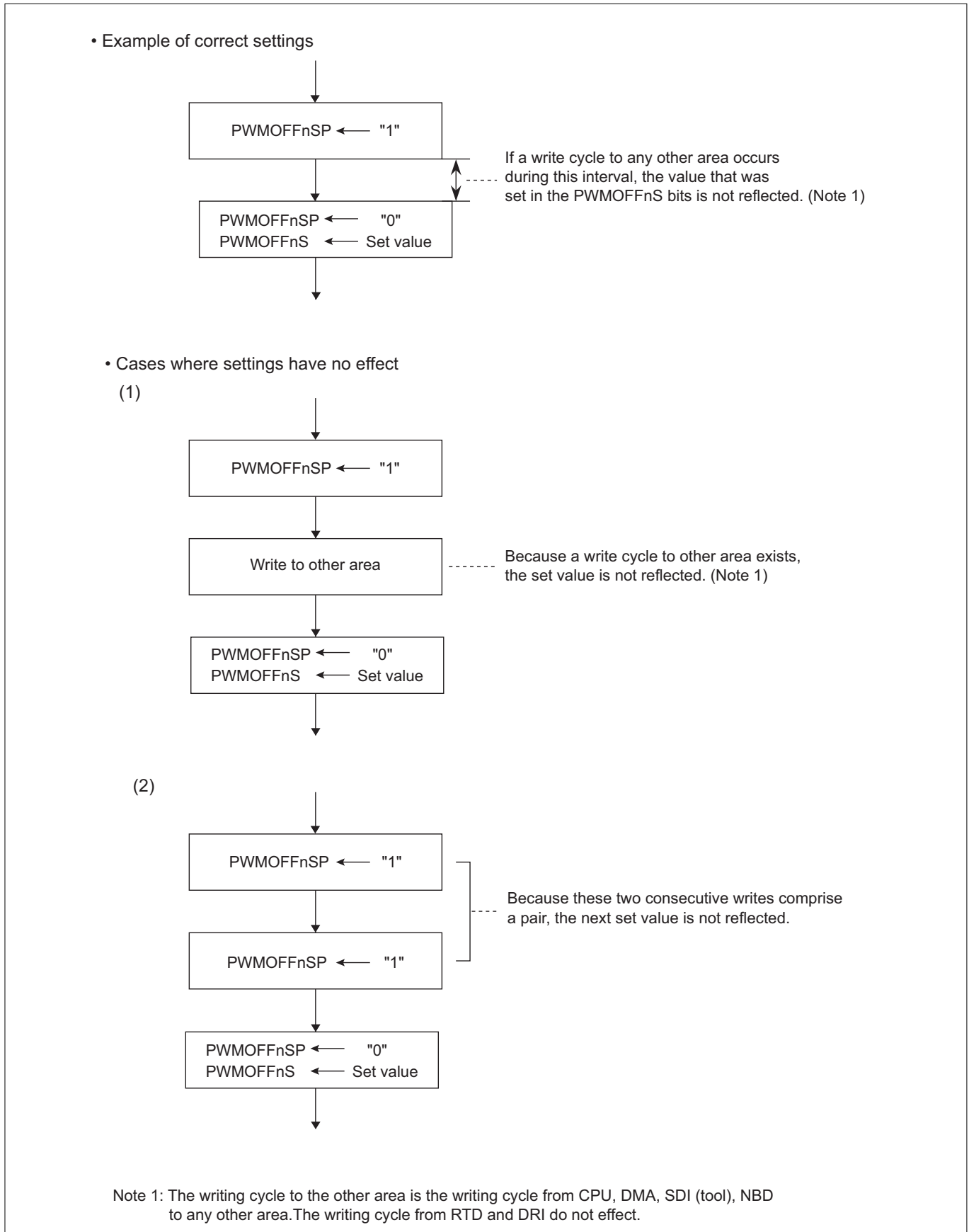
b	Bit Name	Function	R	W
0–3	No function assigned. Fix to "0."		0	0
4	PWMOFF1SP PWMOFF1S write control bit	–	0	W
5–7	PWMOFF1S PWMOFF1 input processing control bit	000: Input has no effect 001: Rising edge 010: Falling edge 011: Both edges 10X: "L" level 11X: "H" level	R	W

The PWMOFF input processing control registers are used to set the active edge or level entered for PWM output disable control from an external pin. For details about the PWM output disable function, see Section 10.8.20, "PWM Output Disable Function."

To set the PWMOFF input processing control bits, follow the procedure described below.

1. Write data "1" to the PWMOFFnS write control bit (PWMOFFnSP).
2. After 1 above, write data "0" to the PWMOFFnS write control bit (PWMOFFnSP) and the set value to the PWMOFF input processing control bits (PWMOFFnS).

Note: • If there are Writing cycles from CPU, DMA, SDI (tool), NBD to any other area between 1 and 2, the continuous setting (A pair of two consecutive is 1 set for writing operation) is disabled and the writing value is not reflected. Therefore, disable interrupts and DMA transfers before setting. However the writing cycle from RTD and DRI are not effected.



**Figure 10.8.5 PWMOFFnS Setting Procedure**

## 10.8.11 PWM Output Disable Control Registers

PWM Output 0 Disable Control Register GA (PO0DISGACR) &lt;Address: H'0080 0520&gt;

b0	1	2	3	4	5	6	b7
0	0	0	0	0	0	PO0DISGAP 0	PO0DISGA 0

<Upon exiting reset: H'00>

b	Bit Name	Function	R	W
0-5	No function assigned. Fix to "0."		0	0
6	PO0DISGAP PO0DISGA write control bit	–	0	W
7	PO0DISGA P87/TO21–P82/TO26 output disable select bit	0: Enable output 1: Disable output	R	W

PWM Output 1 Disable Control Register GA (PO1DISGACR) &lt;Address: H'0080 0522&gt;

b0	1	2	3	4	5	6	b7
0	0	0	0	0	0	PO1DISGAP 0	PO1DISGA 0

<Upon exiting reset: H'00>

b	Bit Name	Function	R	W
0-5	No function assigned. Fix to "0."		0	0
6	PO1DISGAP PO1DISGA write control bit	–	0	W
7	PO1DISGA P110/TO29–P115/TO34 output disable select bit	0: Enable output 1: Disable output	R	W

PWM Output 0 Disable Control Register GB (PO0DISGBCR) &lt;Address: H'0080 0780&gt;

b0	1	2	3	4	5	6	b7
0	0	0	0	0	0	PO0DISGBP 0	PO0DISGB 0

<Upon exiting reset: H'00>

b	Bit Name	Function	R	W
0-5	No function assigned. Fix to "0."		0	0
6	PO0DISGBP PO0DISGB write control bit	–	0	W
7	PO0DISGB P00/TO21–P05/TO26 output disable select bit	0: Enable output 1: Disable output	R	W

PWM output disable control register is a register which performs disable control of the PWM output from TO 21~26 and TO29~TO34 terminal. Refer to the "10.8.20 PWM Output Disable Function" for the details of PWM Output Disable Function.

The procedure of setting up a POnDISGm bit is described blow.

1. Set POnDISGmP Bit of POnDISGmCR as "1" and write it.
2. Write "0" in POnDISGmP Bit and write setting value in POnDISGm Bit.

Note: • If there are writing cycles from CPU, DMA, SDI (tool), NBD to any other area between 1 and 2, the continuous setting ( A pair of two consecutive is 1 set for writing operation) is disabled and the writing value is not reflected. Therefore, disable interrupts and DMA transfers before setting. However the writing cycle from RTD and DRI are not effected.



PWM Output 1 Disable Control Register GB (PO1DISGBCR)

&lt;Address: H'0080 0782&gt;

b0	1	2	3	4	5	6	b7
0	0	0	0	0	0	PO1DISGBP 0	PO1DISGB 0

&lt;Upon exiting reset: H'00&gt;

b	Bit Name	Function	R	W
0–5	No function assigned. Fix to "0."		0	0
6	PO1DISGBP PO1DISGB write control bit	–	0	W
7	PO1DISGB P10/TO29–P15/TO34 output disable select bit	0: Enable output 1: Disable output	R	W

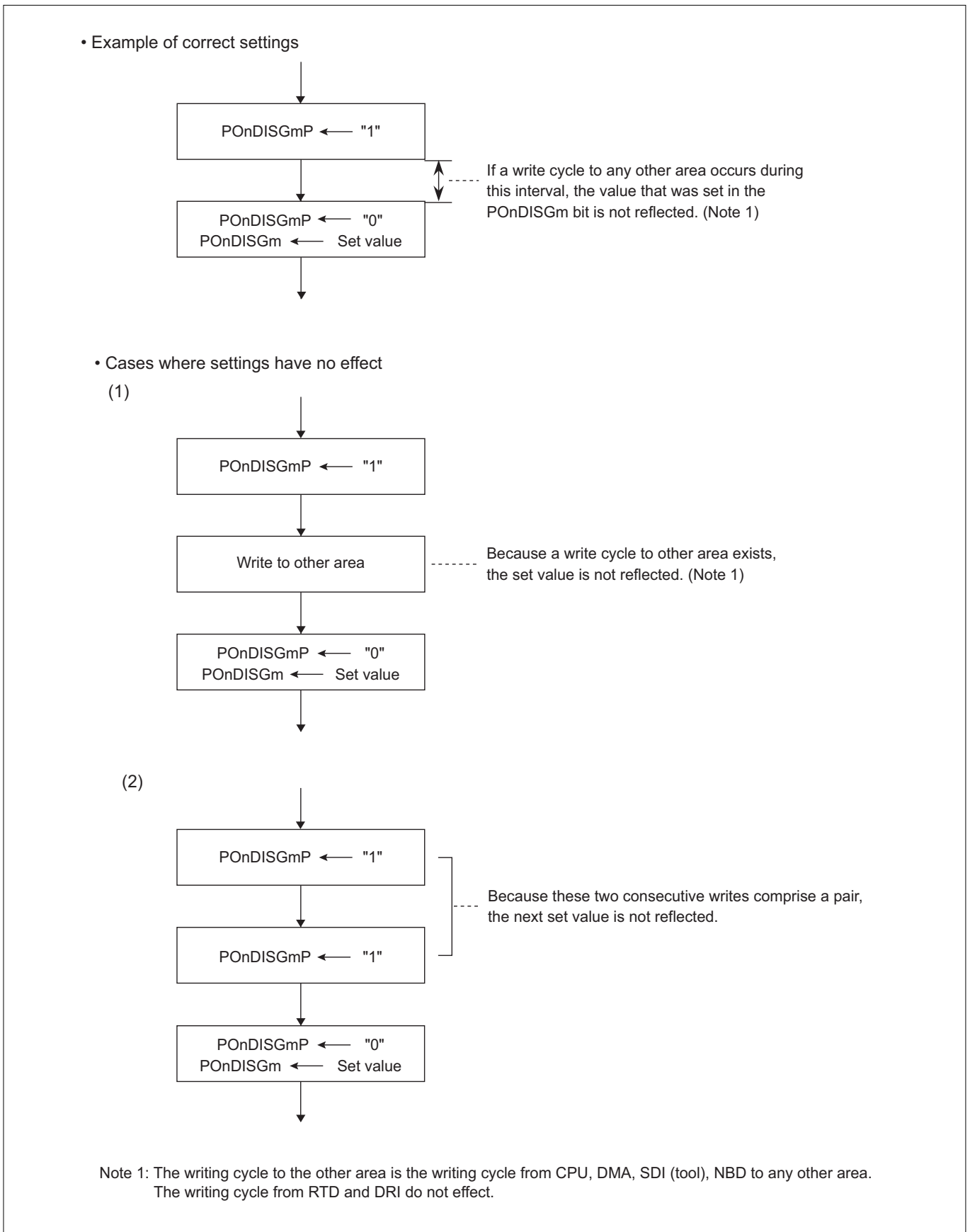
These registers control output from the respective corresponding pins by enabling or disabling it. These pins can be used to control three-phase PWM output using the TOU timer.

Three-phase PWM output can be forcibly disabled (placed in the high-impedance state) by controlling this register. This function can be used for all of output modes or port outputs of TOU. However, use for other modes (external bus, SIO mode, DRI mode and TOP output modes (TO0-TO5) port inputs) is prohibited. For details, see Section 10.8.20, "PWM Output Disable Function." Also, if this register is accessed for read, it serves as a status register indicating whether PWM output is disabled.

To set this register, follow the procedure described below. (In the case of register Gm)

1. Write data "1" to the POnDISGm write control bit (POnDISGmP).
2. After 1 above, write data "0" to the POnDISGm write control bit (POnDISGmP) and data "0" or "1" to the output disable select bit (POnDISGm).

Note: • If there are writing cycles from CPU, DMA, SDI (tool), NBD to any other area between 1 and 2, the continuous setting (A pair of two consecutive is 1 set for writing operation) is disabled and the writing value is not reflected. Therefore, disable interrupts and DMA transfers before setting. However the writing cycle from RTD and DRI are not effected.



**Figure 10.8.6 POnDISGm Setting Procedure**

## 10.8.12 PWM Output Disable Level Control Registers

PWM Output 0 Disable Level Control Register GA (PO0LVGACR)

&lt;Address: H'0080 0521&gt;

b8	9	10	11	12	13	14	b15
0	0	0	0	0	0	PO0LVSELGA	PO0LVENGA
						0	0

&lt;Upon exiting reset: H'00&gt;

b	Bit Name	Function	R	W
8–13	No function assigned. Fix to "0."		0	0
14	PO0LVSELGA P87/TO21–P82/TO26 output disable level select bit	0: Select "L" output disable level 1: Select "H" output disable level	R	W
15	PO0LVENGA Output disable level enable/disable select bit	0: Disable selected output disable level 1: Enable selected output disable level	R	W

PWM Output 1 Disable Level Control Register GA (PO1LVGACR)

&lt;Address: H'0080 0523&gt;

b8	9	10	11	12	13	14	b15
0	0	0	0	0	0	PO1LVSELGA	PO1LVENGA
						0	0

&lt;Upon exiting reset: H'00&gt;

b	Bit Name	Function	R	W
8–13	No function assigned. Fix to "0."		0	0
14	PO1LVSELGA P110/TO29–P115/TO34 output disable level select bit	0: Select "L" output disable level 1: Select "H" output disable level	R	W
15	PO1LVENGA Output disable level enable/disable select bit	0: Disable selected output disable level 1: Enable selected output disable level	R	W

PWM Output 0 Disable Level Control Register GB (PO0LVGBCR)

&lt;Address: H'0080 0781&gt;

b8	9	10	11	12	13	14	b15
0	0	0	0	0	0	PO0LVSELGB	PO0LVENGB
						0	0

&lt;Upon exiting reset: H'00&gt;

b	Bit Name	Function	R	W
8–13	No function assigned. Fix to "0."		0	0
14	PO0LVSELGB P00/TO21–P05/TO26 output disable level select bit	0: Select "L" output disable level 1: Select "H" output disable level	R	W
15	PO0LVENGB Output disable level enable/disable select bit	0: Disable selected output disable level 1: Enable selected output disable level	R	W

PWM Output 1 Disable Level Control Register GB (PO1LVGBCR)

&lt;Address: H'0080 0783&gt;

b8	9	10	11	12	13	14	b15
0	0	0	0	0	0	PO1LVSELGB	PO1LVENGB
						0	0

&lt;Upon exiting reset: H'00&gt;

b	Bit Name	Function	R	W
8–13	No function assigned. Fix to "0."		0	0
14	PO1LVSELGB P10/TO29–P15/TO34 output disable level select bit	0: Select "L" output disable level 1: Select "H" output disable level	R	W
15	PO1LVENGB Output disable level enable/disable select bit	0: Disable selected output disable level 1: Enable selected output disable level	R	W

The output disable level select function allows output from a port to be forcibly disabled (placed in the high-impedance state) depending on the output state of that port.

This function may be used to determine whether three-phase PWM output signals are simultaneously on. Furthermore, this function may be used for double-verification of ports because it works depending on the output state of ports. This function can be used for all of output modes or port outputs of TOU. However, use for other modes (external bus, SIO mode, DRI mode and TOP output modes (TO0-TO5) port inputs) is prohibited. For details, see Section 10.8.20, "PWM Output Disable Function."

### (1) POnLVSEL (Output Disable Level Select) bit (Bit 14)

This bit specifies the level ("H" or "L") at which port output is to be disabled. Set this bit to "0" to disable port output when its level is "L", or "1" to disable port output when its level is "H".

The following shows the conditions under which port output is turned off depending on the port's output state.

#### 1) PO0LVSEL = 0

If any one of the following conditions hold true, TO21–TO26 outputs (TOU0\_0–TOU0\_5 output pins) are disabled.

- TO21 (TOU0\_0 output pin) output and TO22 (TOU0\_1 output pin) output both are at the "L" level
- TO23 (TOU0\_2 output pin) output and TO24 (TOU0\_3 output pin) output both are at the "L" level
- TO25 (TOU0\_4 output pin) output and TO26 (TOU0\_5 output pin) output both are at the "L" level

#### 2) PO0LVSEL = 1

If any one of the following conditions hold true, TO21–TO26 outputs (TOU0\_0–TOU0\_5 output pins) are disabled.

- TO21 (TOU0\_0 output pin) output and TO22 (TOU0\_1 output pin) output both are at the "H" level
- TO23 (TOU0\_2 output pin) output and TO24 (TOU0\_3 output pin) output both are at the "H" level
- TO25 (TOU0\_4 output pin) output and TO26 (TOU0\_5 output pin) output both are at the "H" level

#### 3) PO1LVSEL = 0

If any one of the following conditions hold true, TO29–P185/TO34 outputs (TOU1\_0–TOU1\_5 output pins) are disabled.

- TO29 (TOU1\_0 output pin) output and TO30 (TOU1\_1 output pin) output both are at the "L" level
- TO31 (TOU1\_2 output pin) output and TO32 (TOU1\_3 output pin) output both are at the "L" level
- TO33 (TOU1\_4 output pin) output and TO34 (TOU1\_5 output pin) output both are at the "L" level

#### 4) PO1LVSEL = 1

If any one of the following conditions hold true, TO29–TO34 outputs (TOU1\_0–TOU1\_5 output pins) are disabled.

- TO29 (TOU1\_0 output pin) output and TO30 (TOU1\_1 output pin) output both are at the "H" level
- TO31 (TOU1\_2 output pin) output and TO32 (TOU1\_3 output pin) output both are at the "H" level
- TO33 (TOU1\_4 output pin) output and TO34 (TOU1\_5 output pin) output both are at the "H" level

### (2) POnLVEN (Output Disable Level Enable/Disable Select) bit (Bit 15)

This bit enables or disables the output disable level that was selected with the POnLVSEL bit. Setting this bit to "1" enables the output disable level selected with the POnLVSEL bit; setting this bit to "0" disables the output disable level selected with the POnLVSEL bit.

## 10.8.13 PWMOFF Function Enable Registers

PWMOFF0 Function Enable Register (PWMOFF0EN)

&lt;Address: H'0080 0526&gt;

b0	1	2	3	4	5	6	b7
PWMOFF0 GBEN 0	PWMOFF0 GAEN 0	0	0	0	0	0	0

&lt;Upon exiting reset: H'00&gt;

b	Bit Name	Function	R	W
0	PWMOFF0GBEN P00–P05PWMOFF function select bit	0: Disable PWMOFF0 function 1: Enable PWMOFF0 function	R	W
1	PWMOFF0GAEN P87–P82PWMOFF function select bit	0: Disable PWMOFF0 function 1: Enable PWMOFF0 function	R	W
2–7	No function assigned. Fix to "0."		0	0

PWMOFF1 Function Enable Register (PWMOFF1EN)

&lt;Address: H'0080 0527&gt;

b8	9	10	11	12	13	14	b15
PWMOFF1 GBEN 0	PWMOFF1 GAEN 0	0	0	0	0	0	0

&lt;Upon exiting reset: H'00&gt;

b	Bit Name	Function	R	W
8	PWMOFF1GBEN P10–P15PWMOFF function select bit	0: Disable PWMOFF1 function 1: Enable PWMOFF1 function	R	W
9	PWMOFF1GAEN P110–P115PWMOFF function select bit	0: Disable PWMOFF1 function 1: Enable PWMOFF1 function	R	W
10–15	No function assigned. Fix to "0."		0	0

These registers enable or disable the PWM output disable function that was selected with the PWMOFF input pin. This function can be used for all of output modes or port outputs of TOU. However, use for other modes (external bus, SIO mode, DRI mode and TOP output modes (TO0-TO5) port inputs) is prohibited. For details, see Section 10.8.20, "PWM Output Disable Function."

### 10.8.14 Operation in TOU PWM Output Mode (without Correction Function)

#### (1) Outline of TOU PWM output mode

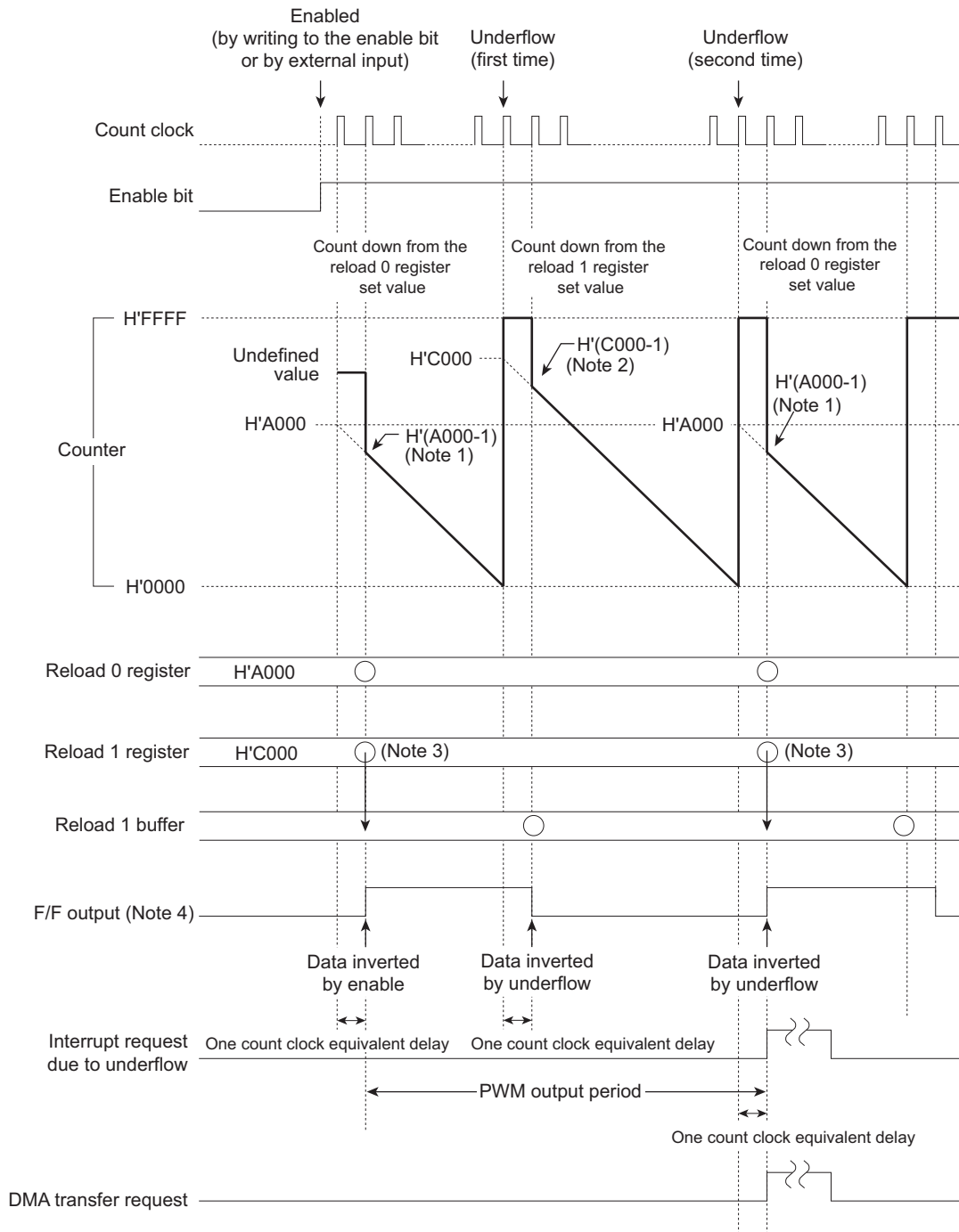
In PWM output mode, the timer uses two reload registers to generate a waveform with a given duty cycle. When in PWM output mode, it is operated as a 16-bit timer.

When the timer is enabled after setting the initial values in the reload 0 and reload 1 registers, the counter is loaded with the value that "the reload 0 register - 1" and starts counting down synchronously with the count clock at the next cycle. The next cycle after the first time the counter underflows, it is loaded with the value that "the reload 1 register - 1" and continues counting. Thereafter, the counter is loaded with the reload 0 and reload 1 register values alternately each time an underflow occurs. The "reload 0 register set value + 1" and "reload 1 register set value + 1" respectively are effective as count values. The timer stops at the same time count is disabled by writing to the enable bit (and not in synchronism with PWM output period).

The F/F output waveform in PWM output mode is inverted (F/F output level changes from "L" to "H" or vice versa) when the counter starts counting and each time it underflows. An interrupt request and DMA transfer request can be generated at even-numbered occurrences of underflow after the counter is enabled.

If the value "H'FFFF" is set in either the reload 0 register or the reload 1 register, F/F output will not be inverted although an interrupt request is generated upon underflow, making it possible to produce a 0% or 100% duty-cycle PWM output. Because a 0% or 100% duty-cycle needs to be determined when reloading the counter, there is a one count clock equivalent delay before F/F is inverted and an interrupt or DMA transfer request is generated. However, startup requests to other timers are not delayed. For details, see Section 10.8.19, "0% or 100% Duty-Cycle Wave Output during PWM Output and Single-shot PWM Output Modes."

Note that TOU's PWM output mode does not have the count correction function.

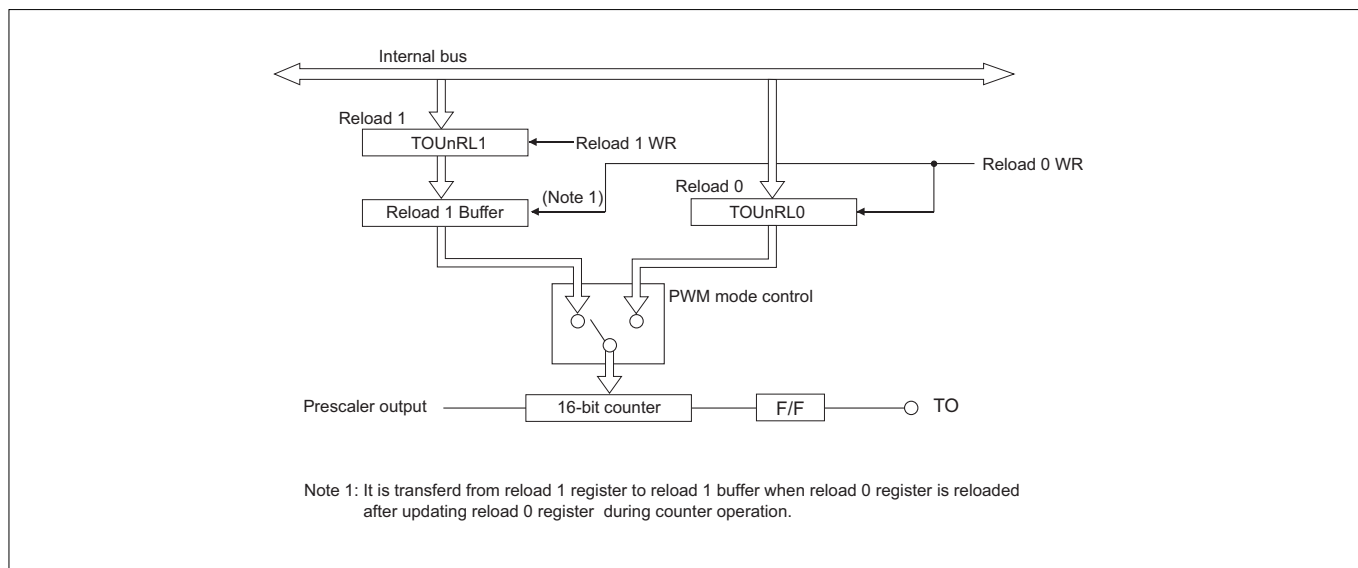


- Note 1: The value that "reload 0 register - 1" is reloaded.  
 Note 2: The value that "reload 1 register - 1" is reloaded.  
 Note 3: When reload0 is reloaded after updating reload0 register, reload 1 buffer is transferd.  
 Note 4: Updating of reload 0 and reload 1 during timer operation does not effect PWM waveform that is outputting at present.  
 Updating is reflected at the next PWM period after updating reload 0 register.  
 Note: • This diagram does not show detailed timing information.

Figure 10.8.7 Typical Operation in PWM Output Mode

**(2) Reload register updates in TOU PWM output mode**

In PWM output mode, when the timer remains idle, the reload 0 and reload 1 registers are updated at the same time data are written to the respective registers. While the timer is operating, the reload 1 register is updated when reload 0 register is reloaded after updating the reload 0 register. However, if the reload 0 and reload 1 registers are accessed for read, the read values are always the data that have been written to the respective registers.



**Figure 10.8.8 PWM Circuit Diagram**

To rewrite the reload 0 and reload 1 registers while the timer is operating, rewrite the reload 1 register first and then the reload 0 register. That way, the reload 0 and reload 1 registers both are updated synchronously with PWM period, from which the timer starts operating. This operation can normally be performed collectively by accessing 32-bit addresses beginning with the reload 1 register address wordwise. (Data are automatically written to the reload 1 and then the reload 0 registers in succession.)

If the reload 0 and reload 1 registers are accessed for read, the read values are always the data that have been written to the respective registers, and not the reload values being actually used.

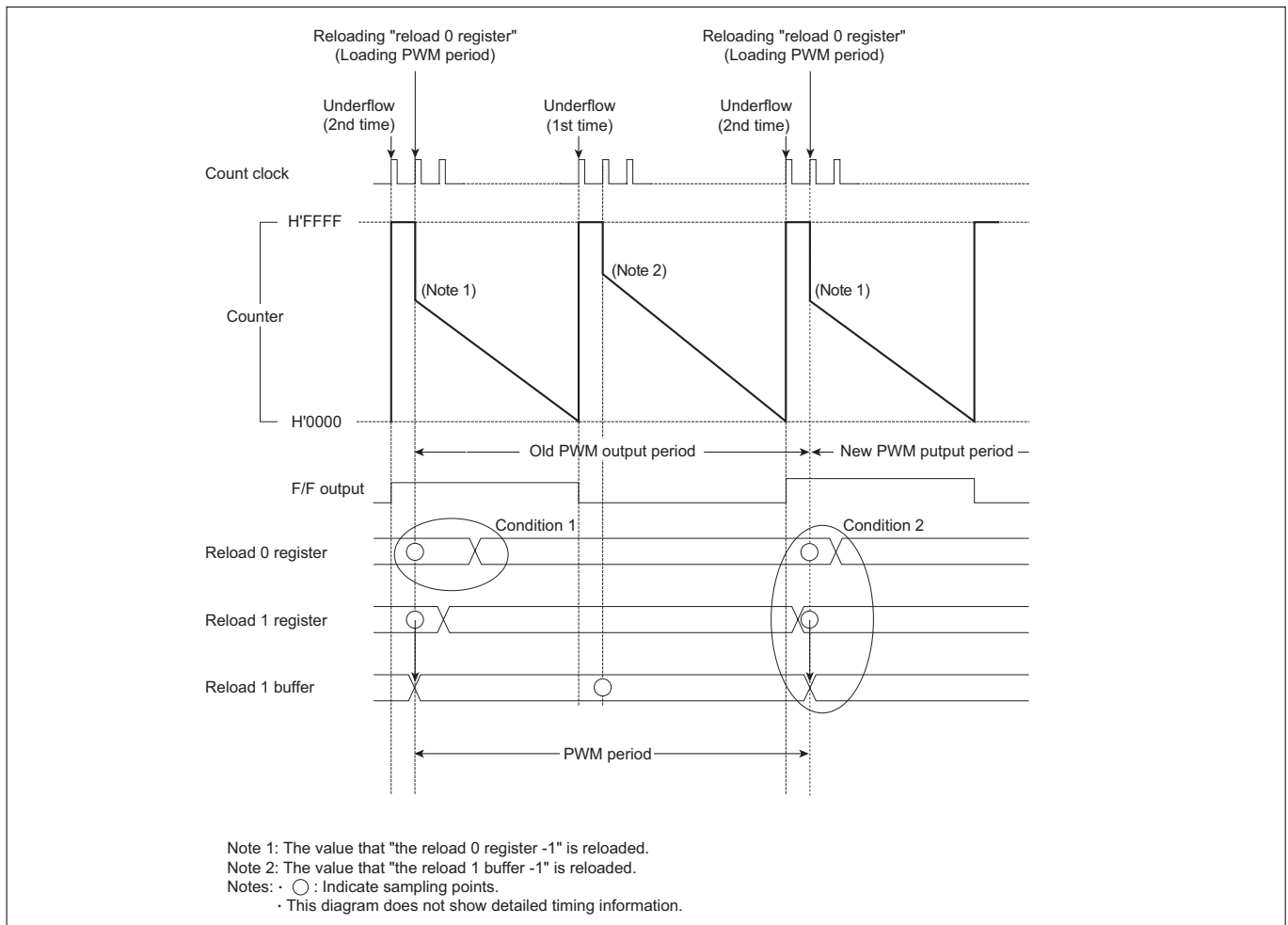
When altering PWM period by rewriting the reload registers, if the PWM period terminates before the CPU finishes writing to reload 0 register, the PWM period is not altered in the current session and the data written to the register is reflected in the next period.

When operating in the PWM output mode, writing the reload 0 register and reload 1 register more than twice within the PWM period and meet the following conditions at the same time, the PWM waveform is output with the value that the last time written reload 0 register and finally written reload 1 register.

Condition 1: Start writing reload 0 register after latching the reload 0 register PWM period of the old PWM output period.

Condition 2: Rewrite reload 1 register before latching PWM period of the new PWM output period and start writing reload 0 register after latching PWM period.





**Figure 10.8.9 Update timing of PWM period**

To update PWM period correctly, take either one of the following measures.

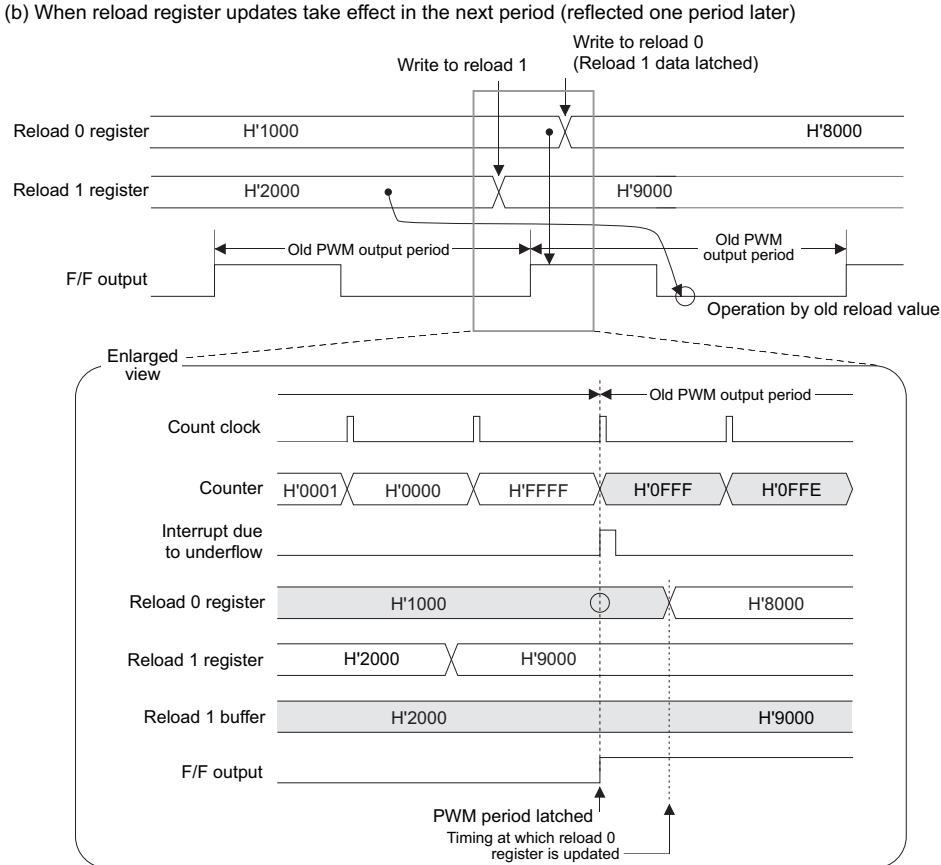
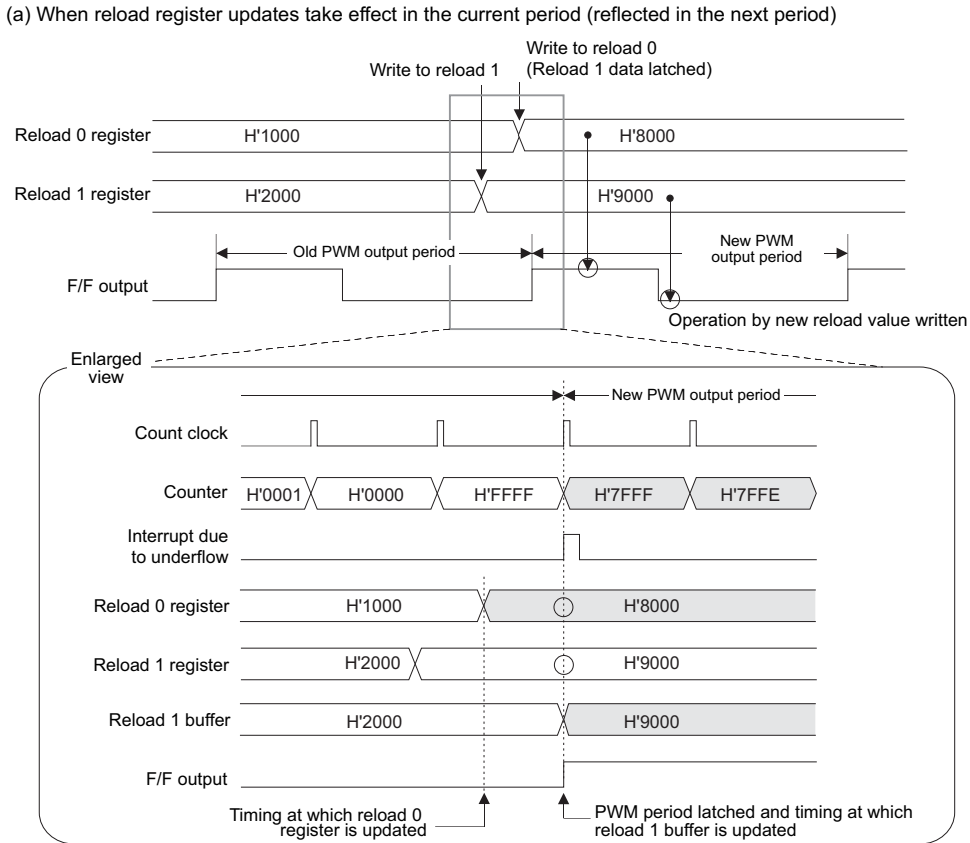
- Identify the completion timing of PWM period by reading counter value at writing reload 1 register and reload 0 register, and then start writing reload 1 register and reload 0 register without crossing PWM period.
- When writing to reload 1 register and reload 0 register by using interruption, set the prescaler value of counter as small as possible. By doing this, write to reload 1 register and reload 0 register later than the counter to be H'FFFF in the PWM period.
- Writing reload 1 register and reload 0 register is performed under the period, less than one time per PWM period. (Extend the reload register's rewrite period against PWM period.)

### (3) Notes on using TOU PWM output mode

The following describes precautions to be observed when using TOU PWM output mode.

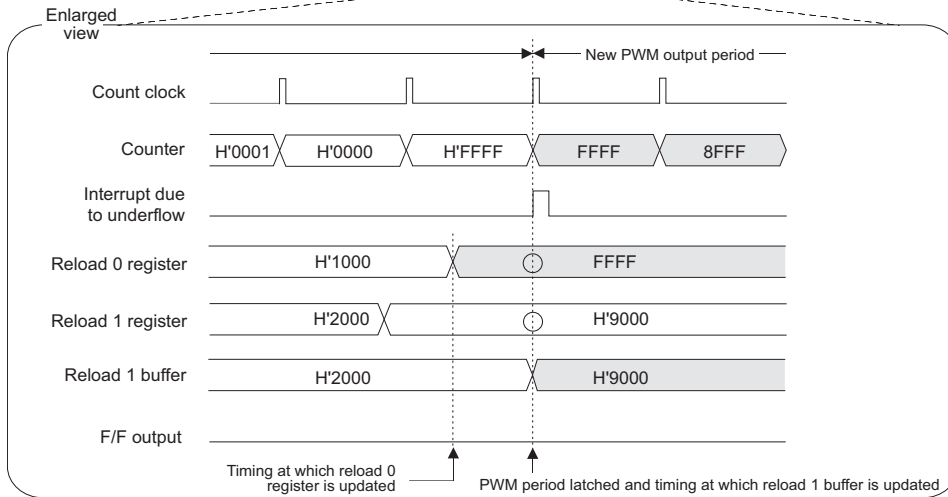
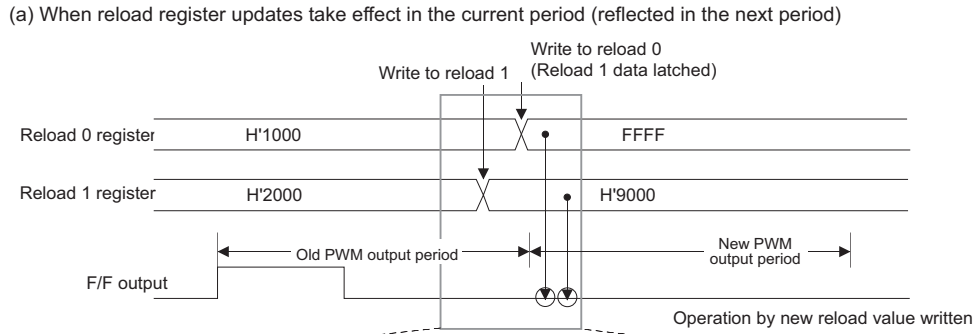
- If the timer is enabled by external input in the same clock period as count is disabled by writing to the enable bit, the latter has priority so that count is disabled.
- If the counter is accessed for read to the cycle of underflow, the counter value is read out as H'FFFF but changes to "reload register value -1" at the next count clock timing.
- Because the timer operates synchronously with the count clock, a count clock-dependent delay is included before F/F output is inverted after the timer is enabled.

Because a 0% or 100% duty-cycle needs to be determined when reloading the counter, there is a one count clock equivalent delay before F/F is inverted and an interrupt or DMA transfer request is generated. However, startup requests to other timers are not delayed. For details, see Section 10.8.19, "0% or 100% Duty-Cycle Wave Output during PWM Output and Single-shot PWM Output Modes."

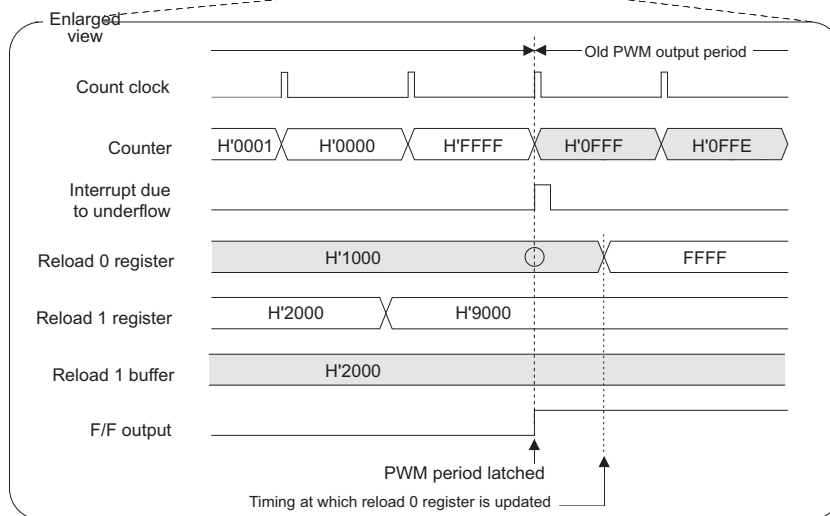
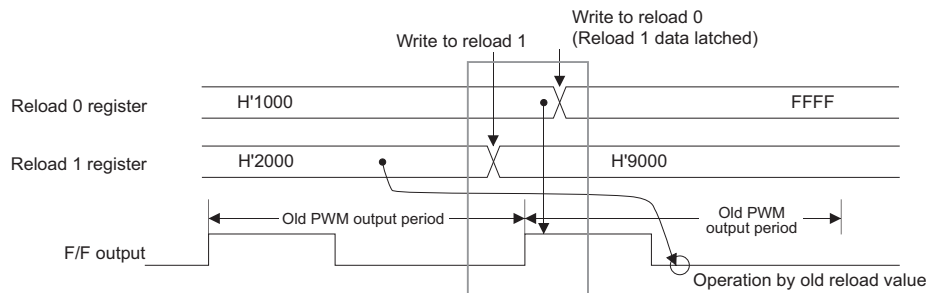


Note: • This diagram does not show detailed timing information.

**Figure 10.8.10 Reload 0 and Reload 1 Register Updates in PWM Output Mode**



(b) When reload register updates take effect in the next period (reflected one period later)



Note: • This diagram does not show detailed timing information.

Figure 10.8.11 Reload 0 and Reload 1 Register Updates in PWM Output Mode (For 0% or 100% Duty-Cycle Wave Output)

### 10.8.15 Operation in TOU Single-shot PWM Output Mode (without Correction Function)

#### (1) Outline of TOU single-shot PWM output mode

In single-shot PWM output mode, the timer uses two reload registers to generate a waveform with a given duty cycle only once. When PWM output mode, it is operated as a 16 bit timer.

When the timer is enabled after setting the initial values in the reload 0 and reload 1 registers, the counter is loaded with the value that "the reload 0 register -1" and starts counting down synchronously with the count clock at the next cycle. At the cycle after the first time the counter underflows, it is loaded with the value that "the reload 1 register -1" and continues counting. The counter stops when it underflows next time. The "reload 0 register set value + 1" and "reload 1 register set value + 1" respectively are effective as count values.

The timer can be stopped in software, in which case it stops at the same time count is disabled by writing to the enable bit (and not in synchronism with PWM output period).

The F/F output waveform in single-shot PWM output mode is inverted (F/F output level changes from "L" to "H" or vice versa) each time the counter underflows. (Unlike in PWM output mode, the F/F output is not inverted when the counter is enabled.) An interrupt request and DMA transfer request can be generated when the counter underflows second time after being enabled.

If the value "H'FFFF" is set in either the reload 0 register or the reload 1 register, F/F output will not be inverted although an interrupt request is generated upon underflow, making it possible to produce a 0% or 100% duty-cycle PWM output. Because a 0% or 100% duty-cycle needs to be determined when reloading the counter, there is a one count clock equivalent delay before F/F is inverted and an interrupt or DMA transfer request is generated. However, startup requests to other timers are not delayed. For details, see Section 10.8.19, "0% or 100% Duty-Cycle Wave Output during PWM Output and Single-shot PWM Output Modes."

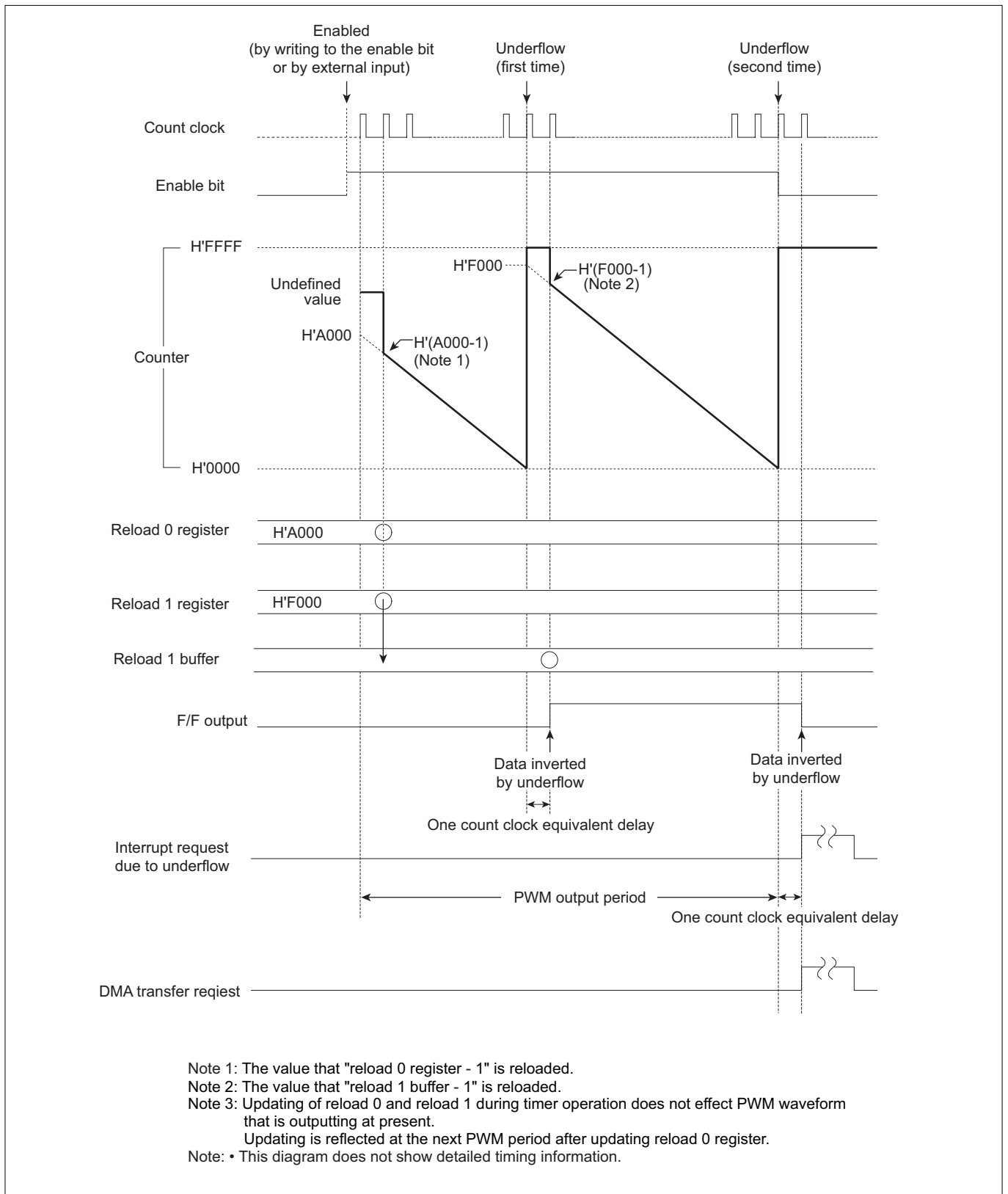
Note that TOU's single-shot PWM output mode does not have the count correction function.

#### (2) Notes on using TOU single-shot PWM output mode

The following describes precautions to be observed when using TOU single-shot PWM output mode.

- If the timer is enabled by external input in the same clock period as count is disabled by writing to the enable bit, the latter has priority so that count is disabled.
- If the counter is accessed for read at the cycle of underflow, the counter value is read out as H'FFFF but changes to "reload register value -1" at the next count clock timing.
- Updating of reload 0 and reload 1 during timer operation does not effect PWM waveform that is outputting at present. Updating is reflected at the next PWM period after updating reload 0 register.

Because a 0% or 100% duty-cycle needs to be determined when reloading the counter, there is a one count clock equivalent delay before F/F is inverted and an interrupt or DMA transfer request is generated. However, startup requests to other timers are not delayed. For details, see Section 10.8.19, "0% or 100% Duty-Cycle Wave Output during PWM Output and Single-shot PWM Output Modes."



**Figure 10.8.12 Typical Operation in TOU Single-shot PWM Output Mode (without Correction Function)**

### 10.8.16 Operation in TOU Delayed Single-shot Output Mode (without Correction Function)

#### (1) Outline of TOU delayed single-shot output mode

In delayed single-shot output mode, the timer generates a pulse in width of "reload register set value + 1" after a finite time equal to "counter set value + 1" only once and then stops.

When the timer is enabled after setting the counter and reload register, it starts counting down from the counter's set value synchronously with the count clock. At the cycle after the first time the counter underflows, it is loaded with the value that "the reload register -1" and continues counting down. The counter stops when it underflows next time.

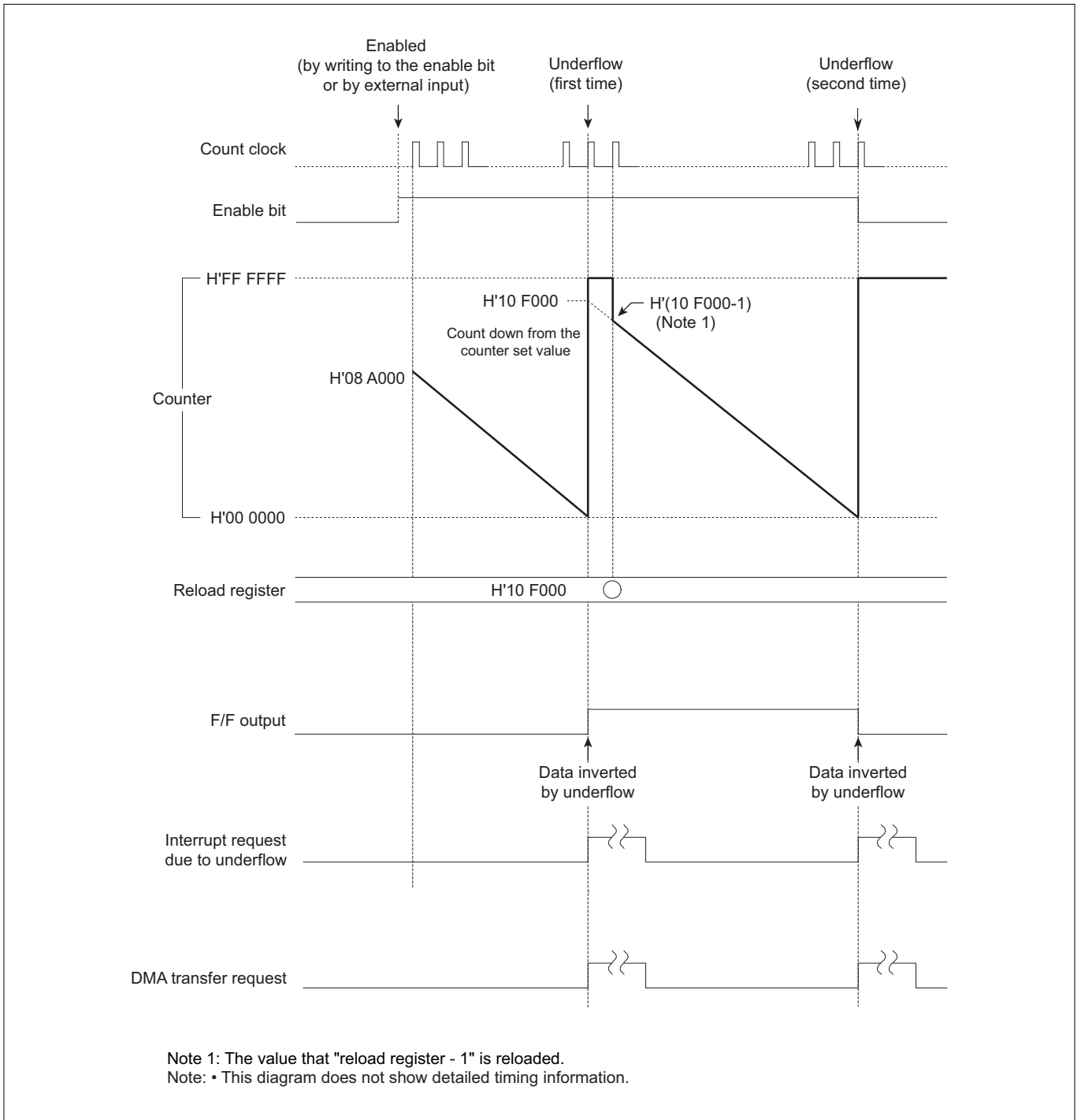
The F/F output waveform in delayed single-shot output mode is inverted (F/F output level changes from "L" to "H" or vice versa) when the counter underflows first time and next, generating a single-shot pulse waveform in width of "reload register set value + 1" after a finite time equal to "first set value of counter + 1" only once. An interrupt request can be generated when the counter underflows first time and next.

The "counter set value + 1" and "reload register set value + 1" respectively are effective as count values. (For counting operation, see also Section 10.3.10, "Operation of TOP Delayed Single-shot Output Mode.")

#### (2) Notes on using TOU delayed single-shot output mode

The following describes precautions to be observed when using TOU delayed single-shot output mode.

- If the counter stops due to an underflow in the same clock period as the timer is enabled by external input, the former has priority so that the counter stops.
- If the counter stops due to an underflow in the same clock period as count is enabled by writing to the enable bit, the latter has priority so that count is enabled.
- If the timer is enabled by external input in the same clock period as count is disabled by writing to the enable bit, the latter has priority so that count is disabled.
- If the counter is accessed for read at the cycle of underflow, the counter value is read as H'FF FFFF but changes to "reload register value -1" at the next count clock timing.
- Because the timer operates synchronously with the count clock, a count clock-dependent delay is included before F/F output is inverted after the timer is enabled.



**Figure 10.8.13 Typical Operation in TOU Delayed Single-shot Output Mode (without Correction Function)**

### 10.8.17 Operation in TOU Single-shot Output Mode (without Correction Function)

#### (1) Outline of TOU single-shot output mode

In single-shot output mode, the timer generates a pulse in width of "reload register set value + 1" only once and then stops.

When the timer is enabled after setting the reload register, the counter is loaded with the content of "the reload register -1" and starts counting synchronously with the count clock at the next cycle. The counter counts down and stops when it underflows after reaching the minimum count.

The F/F output waveform in single-shot output mode is inverted (F/F output levels change from "L" to "H" or vice versa) at startup and upon underflow, generating a single-shot pulse waveform in width of "reload register set value + 1" only once.

An interrupt request and DMA request can be generated when the counter underflows.

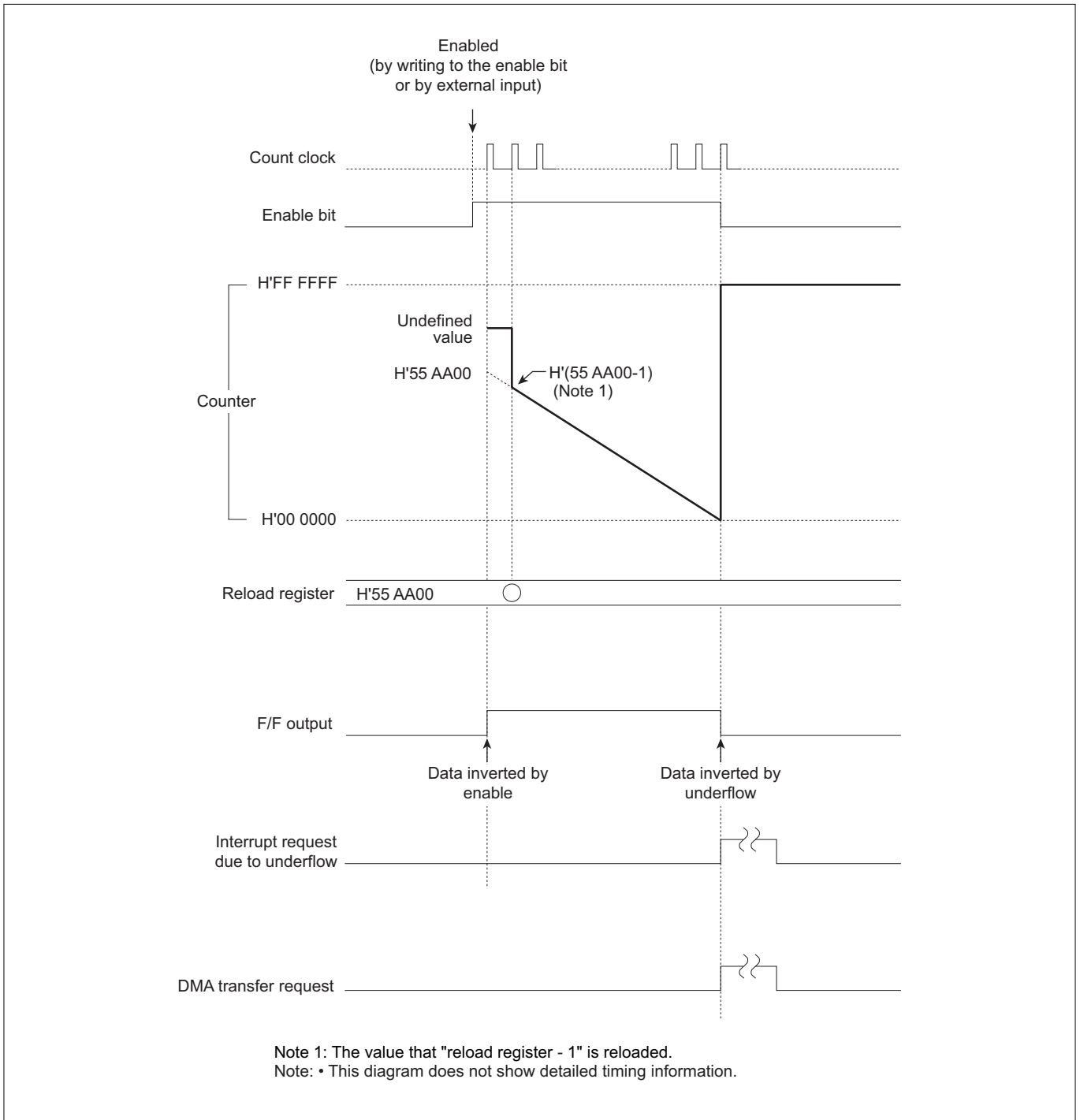
The count value is "reload register set value + 1." (For counting operation, see also Section 10.3.9, "Operation of TOP Single-shot Output Mode.")

#### (2) Notes on using TOU single-shot output mode

The following describes precautions to be observed when using TOU single-shot output mode.

- If the counter stops due to an underflow in the same clock period as the timer is enabled by external input, the former has priority so that the counter stops.
- If the counter stops due to an underflow in the same clock period as count is enabled by writing to the enable bit, the latter has priority so that count is enabled.
- If the timer is enabled by external input in the same clock period as count is disabled by writing to the enable bit, the latter has priority so that count is disabled.
- Because the timer operates synchronously with the count clock, up to one count clock-dependent delay is generated before F/F output is inverted after writing the enable bit.





**Figure 10.8.14 Typical Operation in TOU Single-shot Output Mode (without Correction Function)**

### 10.8.18 Operation in TOU Continuous Output Mode (without Correction Function)

#### (1) Outline of TOU continuous output mode

In continuous output mode, the timer counts down starting from the set value of the counter and when the counter underflows, it is loaded with the reload register value. Thereafter, this operation is repeated each time the counter underflows, thus generating consecutive pulses whose waveform is inverted in width of "reload register set value + 1."

When the timer is enabled after setting the counter and reload register, it starts counting down from the counter's set value synchronously with the count clock and when the minimum count is reached, generates an underflow. At the next cycle after this underflow causes the counter to be loaded with the content of "the reload register - 1" and start counting over again. Thereafter, this operation is repeated each time an underflow occurs. To stop the counter, disable count by writing to the enable bit in software.

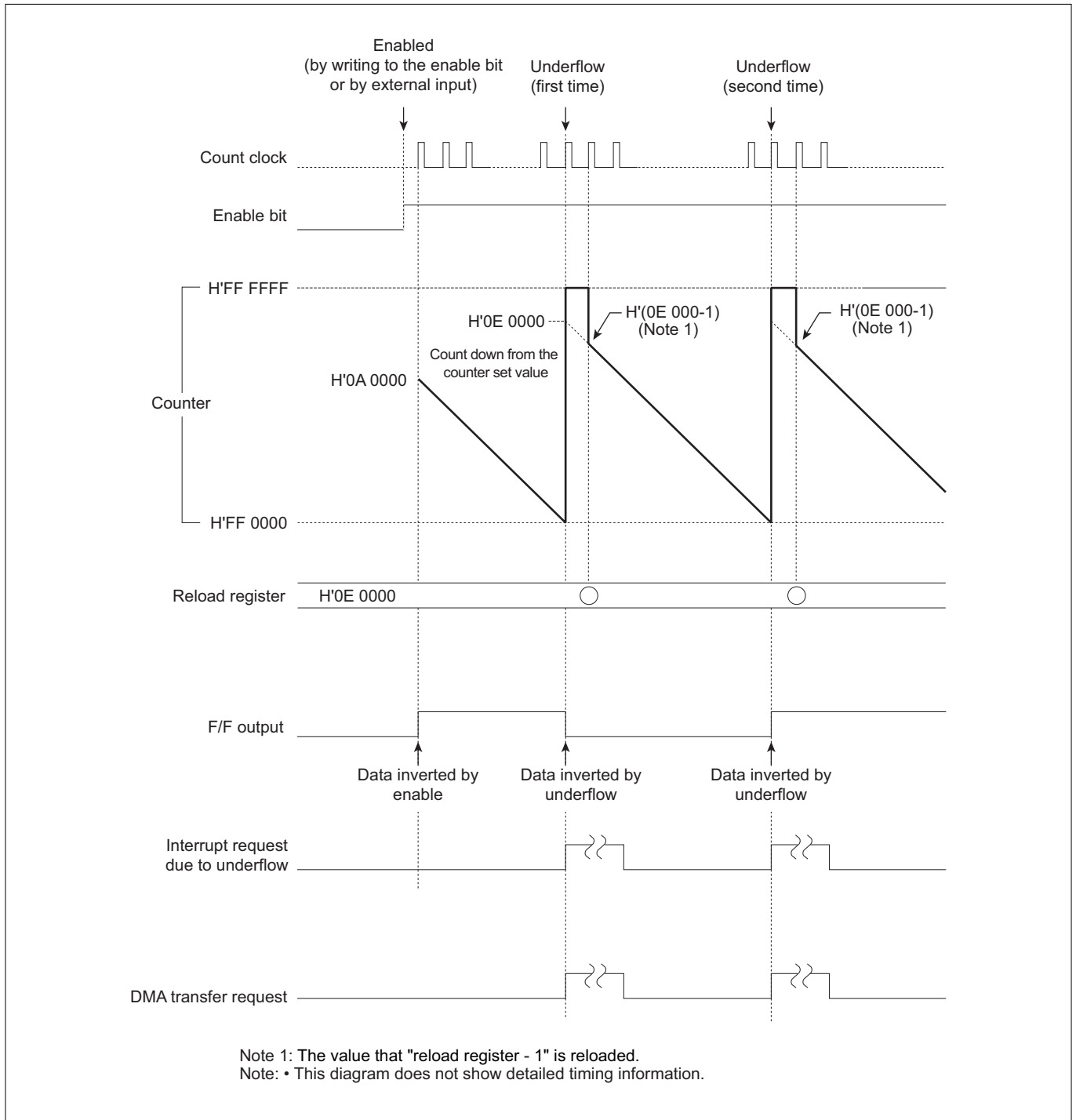
The F/F output waveform in continuous output mode is inverted (F/F output level changes from "L" to "H" or vice versa) at startup and upon underflow, generating a waveform of consecutive pulses until the timer stops counting. An interrupt request and DMA request can be generated each time the counter underflows.

The "counter set value + 1" and "reload register set value + 1" are effective as count values. (For counting operation, see also Section 10.3.11, "Operation of TOP Continuous Output Mode.")

#### (2) Notes on using TOU continuous output mode

The following describes precautions to be observed when using TOU continuous output mode.

- If the timer is enabled by external input in the same clock period as count is disabled by writing to the enable bit, the latter has priority so that count is disabled.
- If the counter is accessed for read at the cycle of underflow, the counter value is read out as H'FF FFFF but changes to "reload register value - 1" at the next count clock timing.
- Because the timer operates synchronously with the count clock, up to one count clock-dependent delay is generated before F/F output is inverted after writing the enable bit.



**Figure 10.8.15 Typical Operation in TOU Continuous Output Mode (without Correction Function)**

#### 10.8.19 0% or 100% Duty-Cycle Wave Output during PWM Output and Single-shot PWM Output Modes

During PWM output or single-shot PWM output mode, if the value "H'FFFF" is written to the reload 0 or reload 1 register, F/F output will not be inverted, making it possible to produce a 0% or 100% duty-cycle PWM output. Because determination is made to see if the reload value is "H'FFFF" during PWM output or single-shot PWM output mode, following precautions must be observed.

- (1) Because the counter counts one even when detecting 0% or 100% duty-cycle, one of the two reload registers must have set in it one less than the intended value in order for a constant-cycle waveform to be produced.

Example: If the desired output cycle is 10 counts

Cycle ratio	50% : 50%	80% : 20%	90% : 10%	100% : 0%
Count ratio	5 : 5	8 : 2	9 : 1	10 : 0
Register set values	0004 : 0004	0007 : 0001	0008 : 0000	<del>0009 : FFFF</del>

Because the counter counts  $n + 1$ , the values actually set in the respective registers must be one less than the intended value.

0008: FFFF

The counter counts one without inverting F/F output after detecting "FFFF." For this reason, the value to be set in the register must be "0008," and not "0009."

- (2) Because setting the value "H'FFFF" in the reload register produces a 0% or 100% duty-cycle, it is impossible to count the exact "H'FFFF."
- (3) Setting the value "H'FFFF" in both reload 0 and reload 1 registers is inhibited.
- (4) Writing the value "H'FFFF" to the counter while in operation is inhibited.
- (5) Even for a 0% or 100% duty-cycle, interrupt requests and startup registers to other timers are generated.
- (6) Because a 0% or 100% duty-cycle needs to be determined when reloading the counter, there is a one count clock equivalent delay before F/F is inverted and an interrupt or DMA transfer request is generated. However, startup requests to other timers are not delayed.

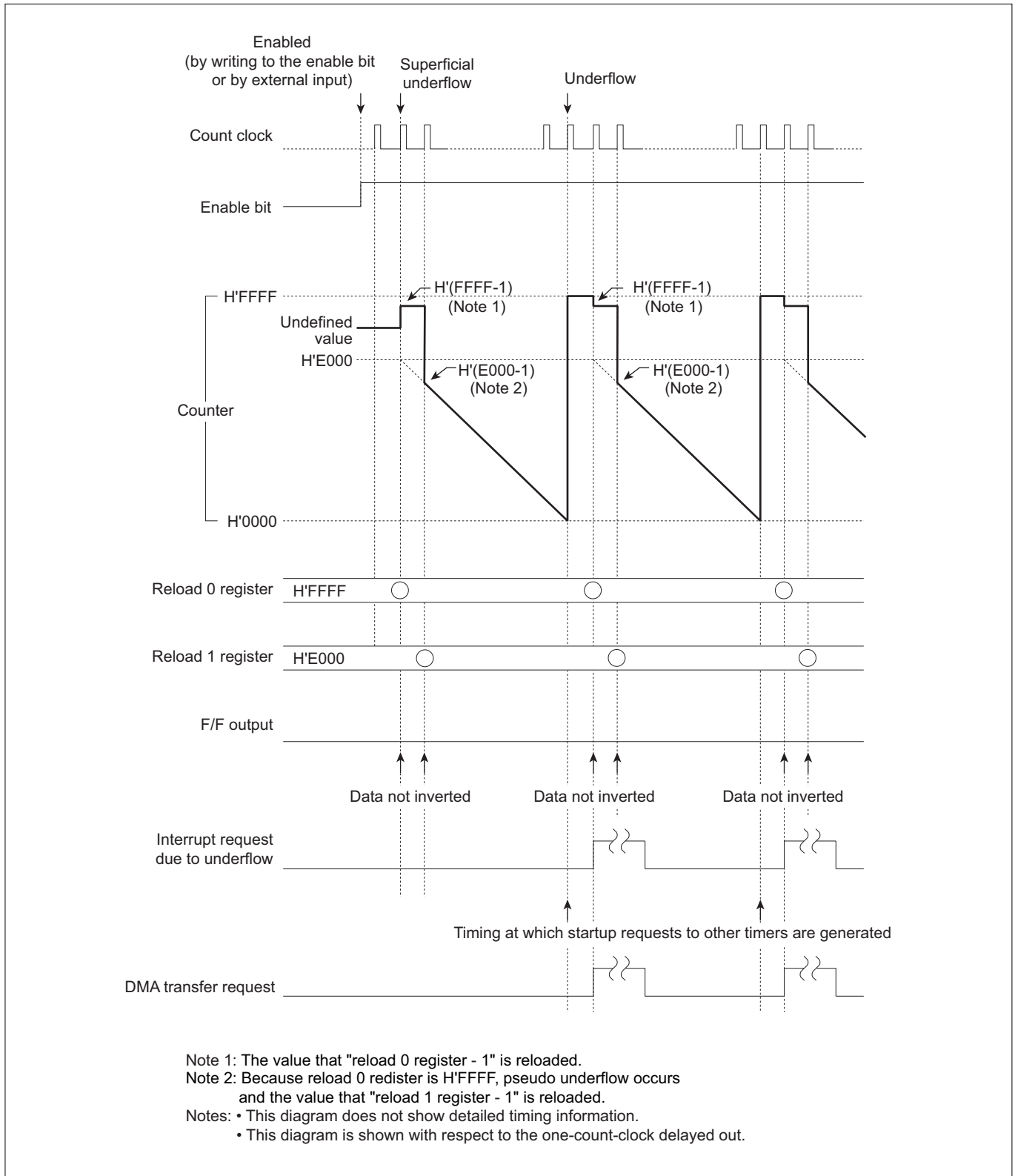
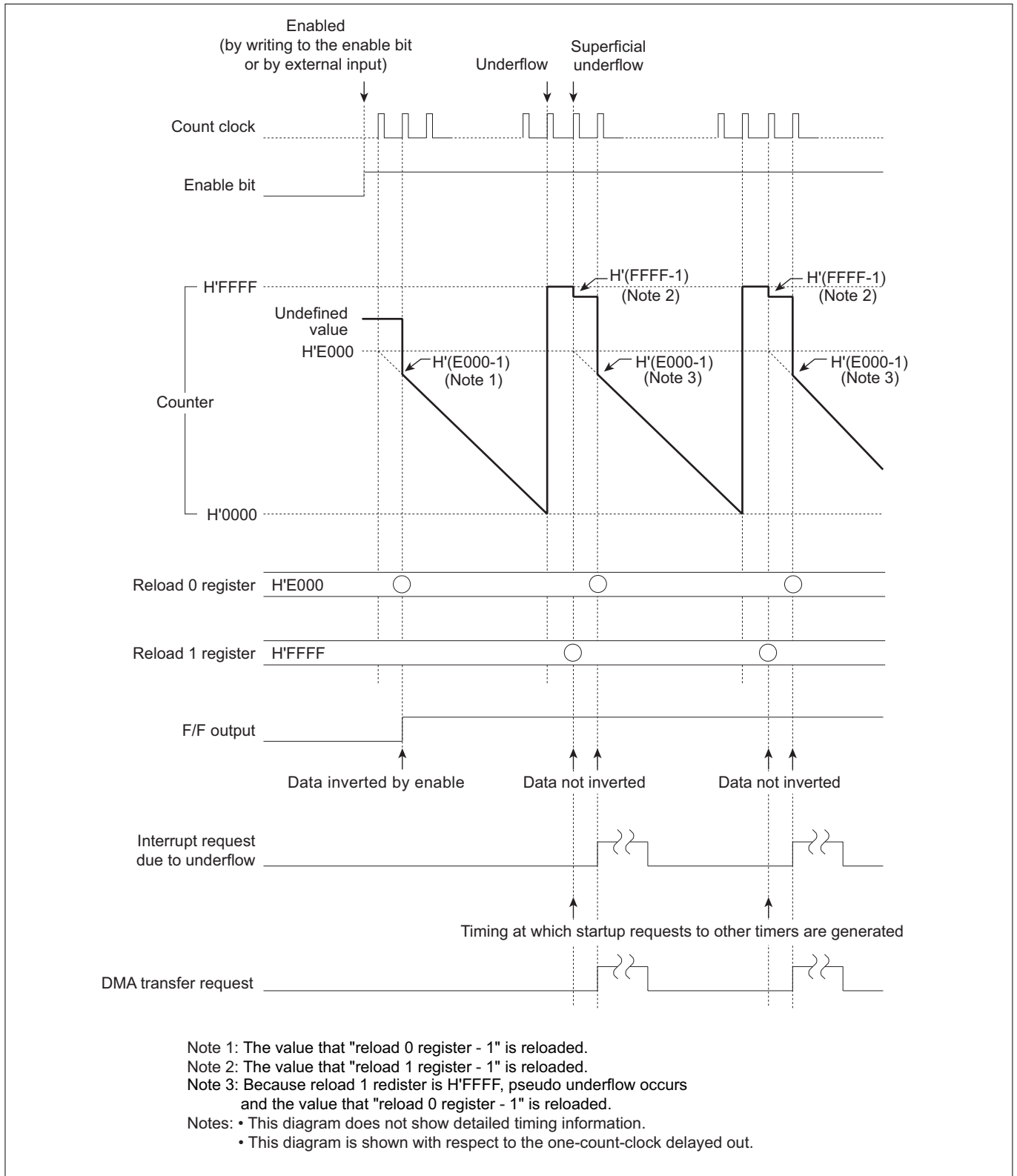
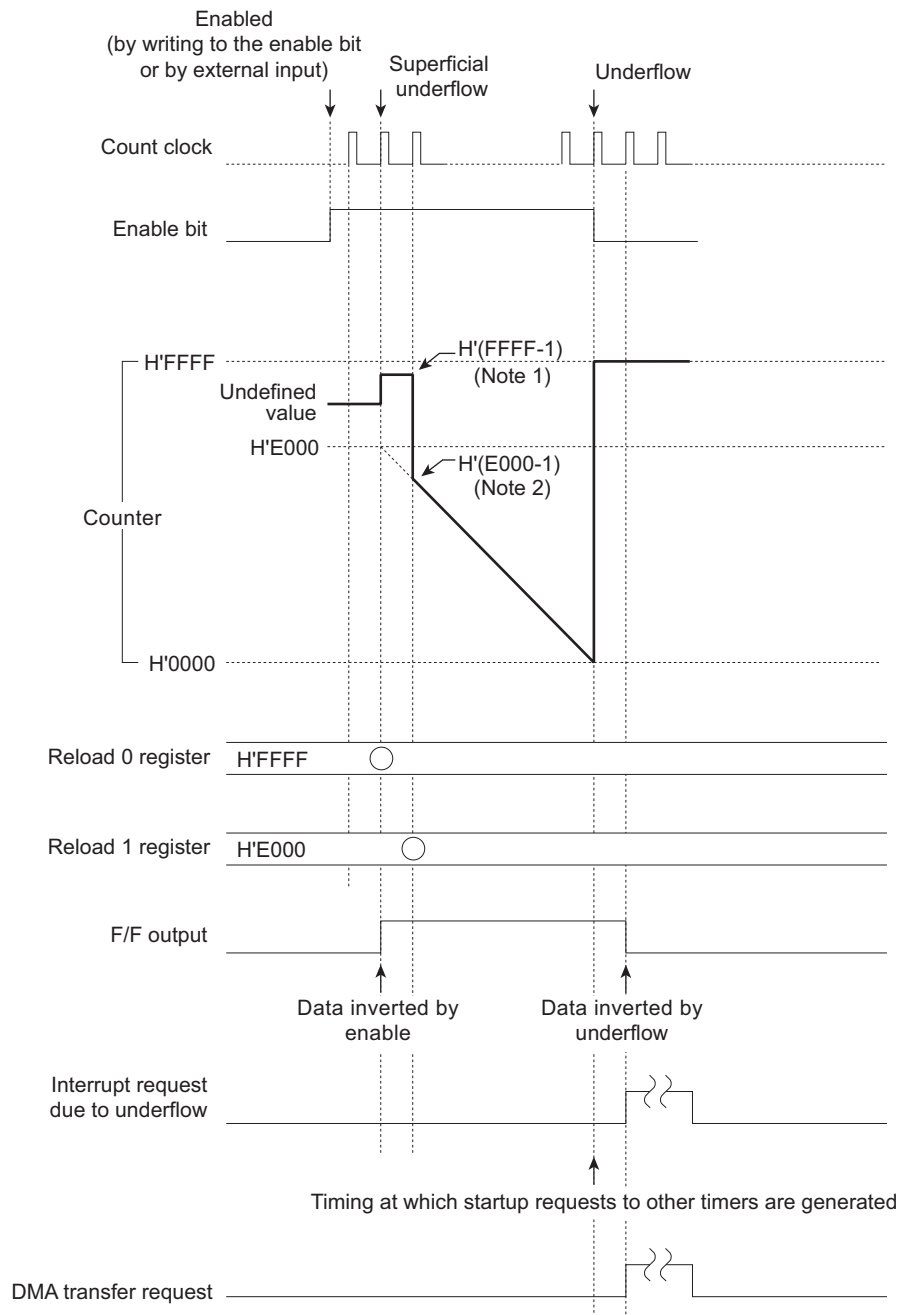


Figure 10.8.16 Typical Operation in PWM Output Mode (Reload 0 Register: H'FFFF)



**Figure 10.8.17 Typical Operation in PWM Output Mode (Reload 1 Register: H'FFFF)**



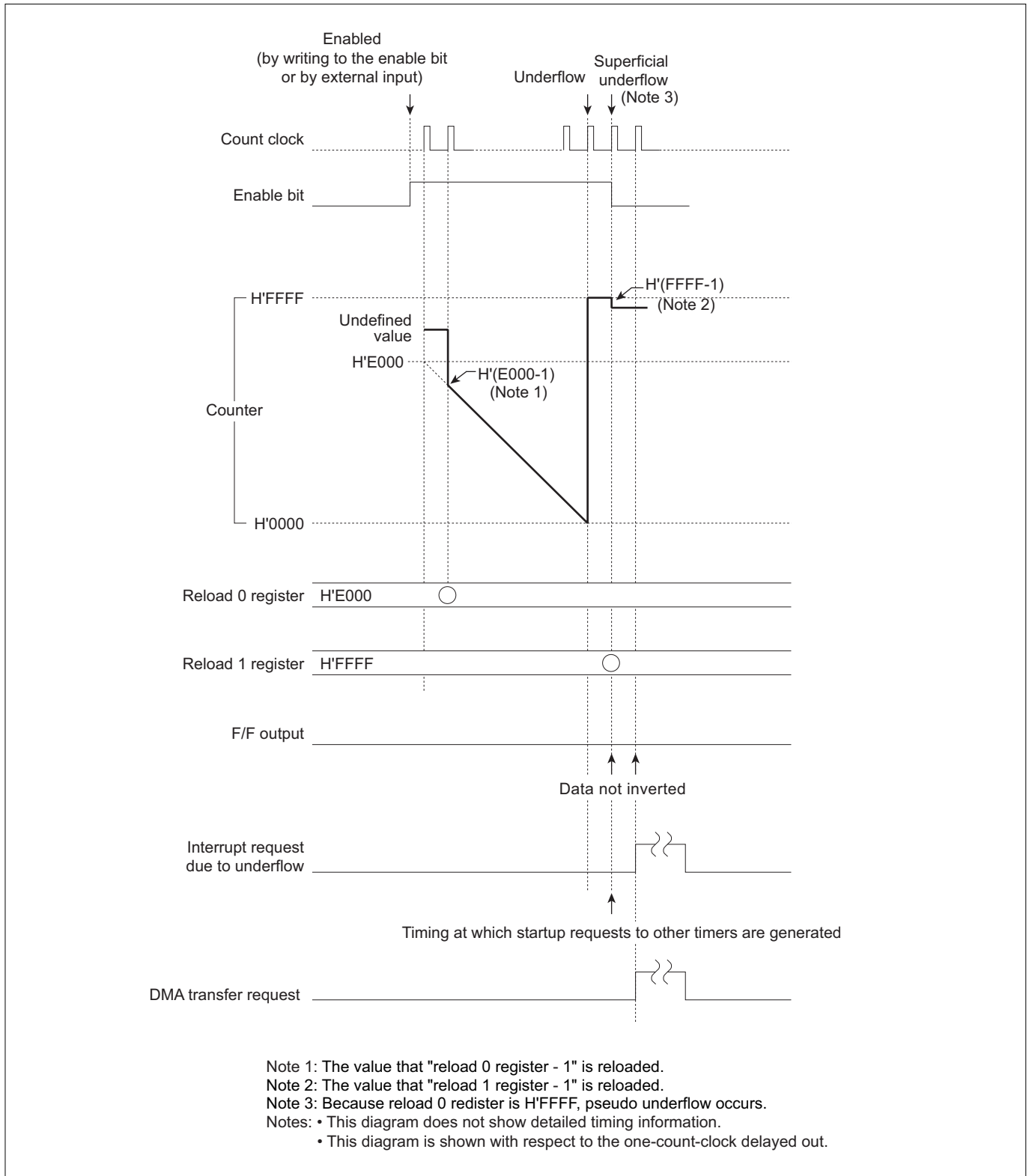
Note 1: The value that "reload 0 register - 1" is reloaded.

Note 2: Because reload 0 register is H'FFFF, pseudo underflow occurs and the value that "reload 1 register - 1" is reloaded.

Notes: • This diagram does not show detailed timing information.

• This diagram is shown with respect to the one-count-clock delayed out.

Figure 10.8.18 Typical Operation in Single-shot PWM Output Mode (Reload 0 Register: H'FFFF)



**Figure 10.8.19 Typical Operation in Single-shot PWM Output Mode (Reload 1 Register:  $H'FFFF$ )**



#### 10.8.20 PWM Output Disable Function

The microcomputer has the function to forcibly disable outputs from the P87(P00)/TO21–P82(P05)/TO26 and P110(P10)/TO29–P115(P15)/TO34 that respectively are the output pins for the TOU0\_0–TOU0\_5 and TOU1\_0–TOU1\_5 timers. This function may be used as a protective function when a fault condition such as short-circuiting is detected during three-phase PWM control. This function can be used for all of output modes or port outputs of TOU. However, use for other modes (external bus, SIO mode, DRI mode and TOP output modes (TO0–TO5) port inputs) is prohibited. Figure 10.8.19 shows the circuit configurations of the PWM output disable function.

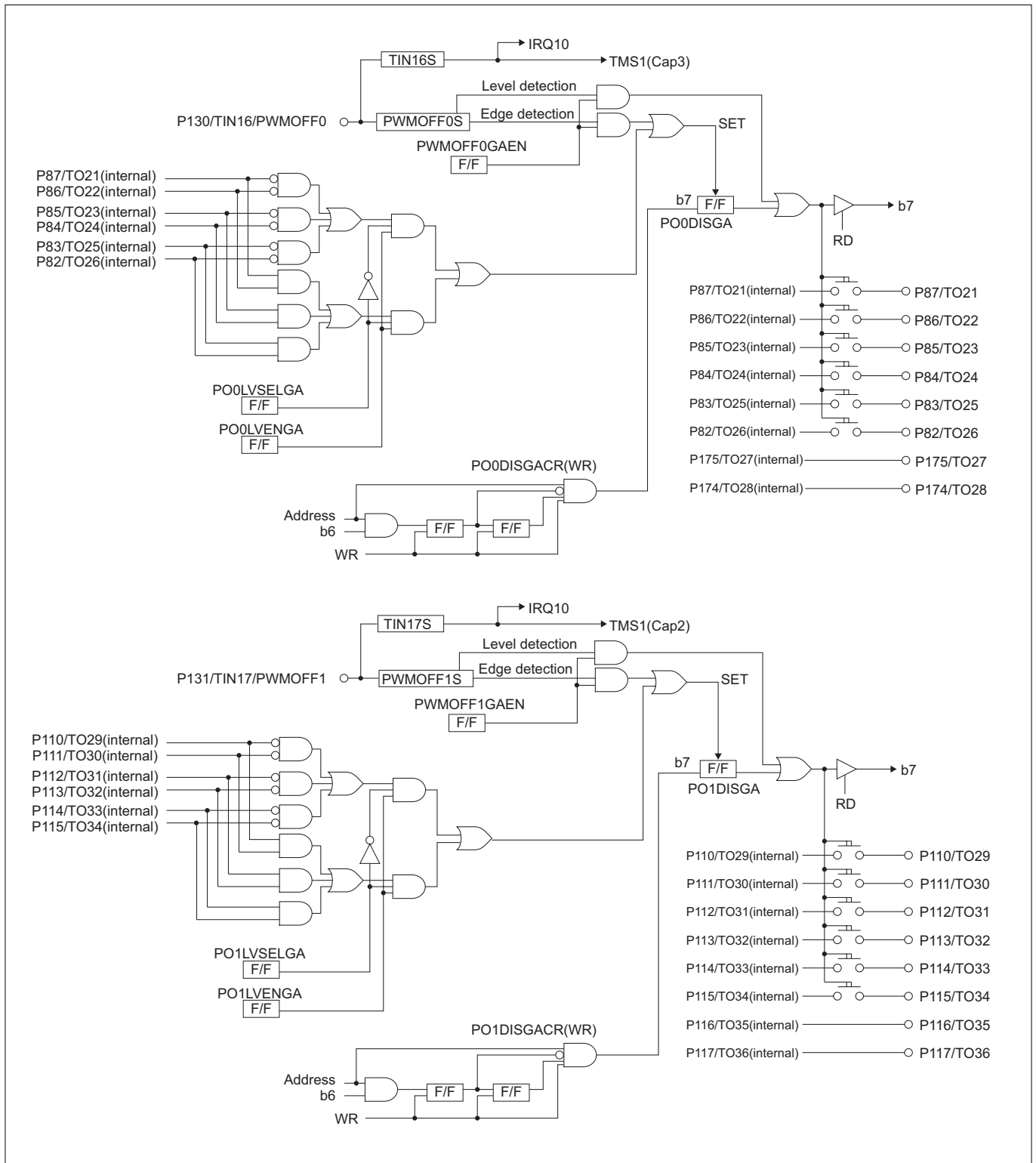


Figure 10.8.20 Circuit Configurations of the PWM Output Disable Function (Pin Group A)

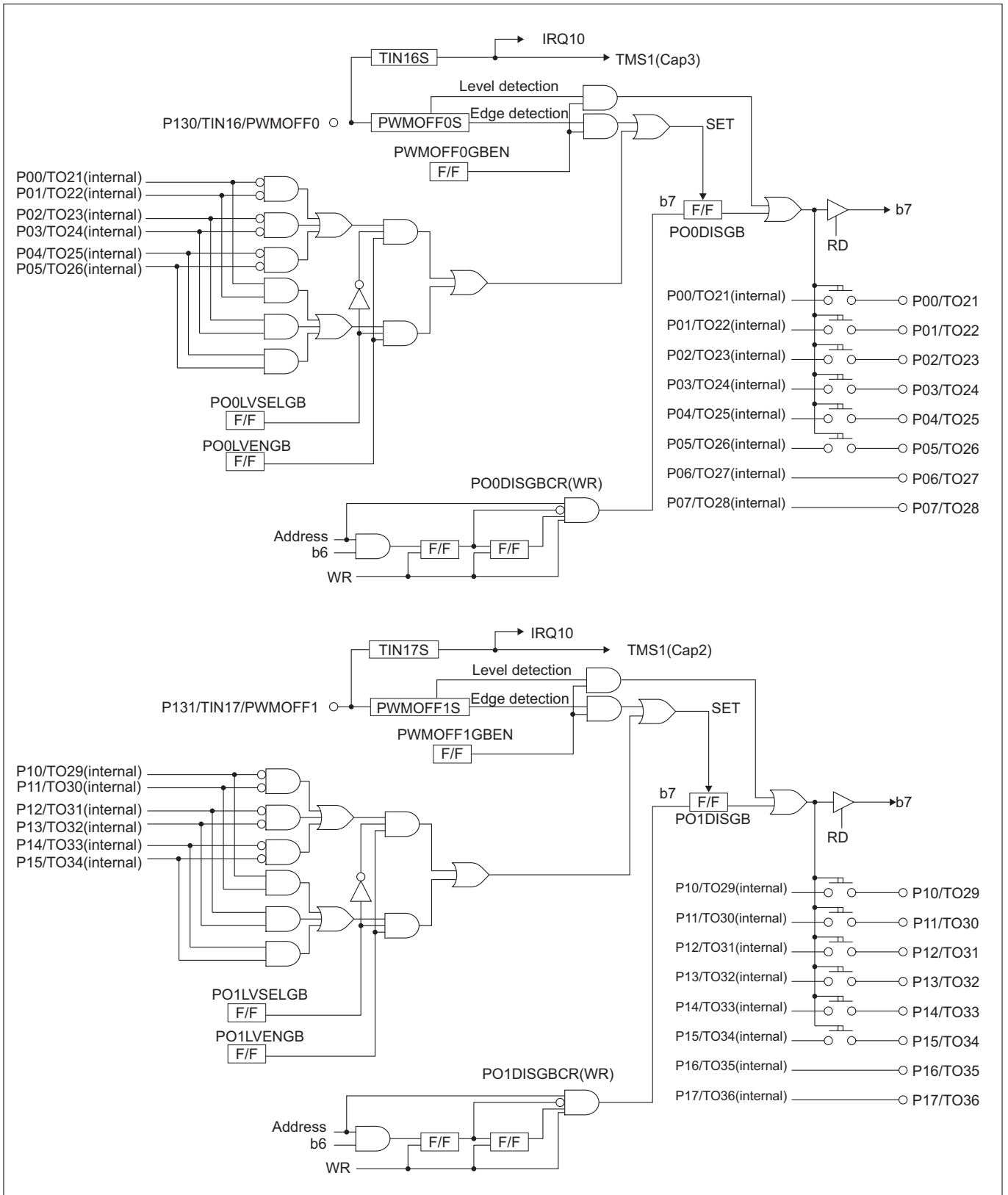


Figure 10.8.21 Circuit Configurations of the PWM Output Disable Function (Pin Group B)

There are following three methods to disable PWM outputs.

**(1) Using the signal entered from an external pin (TIN16/PWMOFF0 or TIN17/PWMOFF1) to disable PWM outputs**

The input signal on the external pin (TIN16/PWMOFF0) may be used to disable outputs from the ports P87(P00)/TO21–P82(P05)/TO26 that are provided for the PWM outputs of the timer TOU0\_0–TOU0\_5. Similarly, the input signal on the external pin (TIN17/PWMOFF1) may be used to disable outputs from the ports P110(P10)/TO29–P115(P15)/TO34 that are provided for the PWM outputs of the timer TOU1\_0–TOU1\_5.

**When selecting rising or falling or both edges at PWMOFFnS bit of PWMOFFn Input Procedure Control Register (PWMOFFnCR)**

When edge detecting in external pin (TIN16/PWMOFF0, TIN17/PWMOFF1, TIN33/PWMOFF2), PWM output is disabled. At that time POnDISGm bit of PWM Output n Disable Control Gm register is set to "1."

Restoring PWM output enable status is done by "0" clearing POnDISGm bit of PWM Output n Disable Control Gm Register (POnDISGmCR).

**When selecting "L" level or "H" level at PWMOFFnS bit of PWMOFFn Input Procedure Control Register (PWMOFFnCR)**

During inputting PWM output disable level to external pin (TIN16/PWMOFF0, TIN17/PWMOFF1, TIN33/PWMOFF2), PWM output is disabled. At that time POnDISGm bit of PWM Output n Disable Control Gm Register is set to "1."

Restoring PWM output enable status is done by exiting inputting PWM output disable level. At that time setting value written in last time is read out from POnDISGm bit of PWM Output n Disable Control Gm Register (POnDISGmCR).

Note: • When write to POnDISGm bit of PWM Output n Disable Control Gm Register during inputting PWM output disable level to external pin (TIN16/PWMOFF0, TIN17/PWMOFF1, TIN33/PWMOFF2), the value written is stored in the register. However, if read out, "1" is read out. Then upon exiting PWM output disable level to external pin, it is possible to read out the contents of setting POnDISGm bit, PWM output is controlled by following the setting value.

To disable PWM outputs by using the input signal on the external pin (TIN16/PWMOFF0 or TIN17/PWMOFF1), set up the PWMOFFn Input Processing Control Register (PWMOFFnCR) and the PWMOFFn Function Enable Register (PWMOFFnEN) as described below.

**When using the signal inputted from TIN16/PWMOFF0 to disable PWM outputs**

1. Write data "1" to the PWMOFF0CR register PWMOFF0SP bit.
2. After 1 above, write data "0" to the PWMOFF0SP bit and then write setting value ("000," "001," "010," "011," "10X" or "11X") to the PWMOFF0S bit in succession.
3. Enable the PWMOFF0 function by writing "1" to either or both of the PWMOFF0GAEN bits and PWMOFF0GBEN bits of the PWMOFF0EN register.

Note: • If there are CPU, DMA, SDI, Writing cycle from NBD to any other area between 1 and 2, the continuous setting (A pair of two consecutive is 1 set for writing operation) is disabled and the writing value is not reflected. Therefore, disable interrupts and DMA transfers before setting. However the writing cycle from RTD and DRI is not effected.

**When using TIN17/PWMOFF1 to disable PWM outputs**

1. Write data "1" to the PWMOFF1CR register PWMOFF1SP bit.
2. After 1 above, write data "0" to the PWMOFF1SP bit and then write setting value ("000," "001," "010," "011," "10X" or "11X") to the PWMOFF1S bit in succession.
3. Enable the PWMOFF1 function by writing "1" to either or both of the PWMOFF1GAEN and PWMOFF1GBEN bits of the PWMOFF1EN register.

Note: • If there are CPU, DMA, SDI, and Writing cycle from NBD to any other area between 1 and 2, the continuous setting (A pair of two consecutive is 1 set for writing operation) is disabled and the writing value is not reflected. Therefore, disable interrupts and DMA transfers before setting. However, the writing cycle from RTD and DRI are not effected.

### (2) Using the PWM Output Disable Control Registers to disable PWM outputs

The PWM Output 0 Disable Control Gm Register (PO0DISGACR, PO0DISGBCR) may be used to disable outputs from the ports P87(P00)/TO21–P82(P05)/TO26 that are provided for the PWM outputs of the timer TOU0\_0–TOU0\_5. Similarly, the PWM Output 1 Disable Control Gm Register (PO1DISGACR, PO1DISGBCR) may be used to disable outputs from the ports P110(P10)/TO29–P115(P15)/TO34 that are provided for the PWM outputs of the timer TOU1\_0–TOU1\_5.

To disable PWM output by the PWM Output Disable Control Gm Register (POnDISGACR, POnDISCBCR) set as described below.

#### When using the PWM Output 0 Disable Control Register (PO0DISGACR, PO0DISGBCR) to disable PWM outputs

1. Set the PO0DISGACR(PO0DISGBCR) register PO0DISGAP(PO0DISGBP) bit to "1."
2. After 1 above, set the PO0DISGAP(PO0DISGBP) bit to "0" and then the PO0DISGA(PO0DISGB) bit to "1" (output disabled).

Note: • If a write cycle to any other area occurs between 1 and 2, the setting of the PO0DISGA (PO0DISGB) bit has no effect.

#### When using the PWM Output 1 Disable Control Register (PO1DISGACR, PO1DISGBCR) to disable PWM outputs

1. Set the PO1DISGACR(PO1DISGBCR) register PO1DISGAP(PO1DISGBP) bit to "1."
2. After 1 above, set the PO1DISGAP(PO1DISGBP) bit to "0" and then the PO1DISGA(PO1DISGB) bit to "1" (output disabled).

Note: • If a write cycle to any other area occurs between 1 and 2, the setting of the PO1DISGA (PO1DISGB) bit has no effect.

### (3) Using the pin level on ports P87(P00)/TO21–P82(P05)/TO26 or P110(P10)/TO29–P115(P15)/TO34 to disable PWM outputs

The pin level ("H" or "L" level) on ports P87(P00)/TO21–P82(P05)/TO26 may be used to disable outputs from the ports P87(P00)/TO21–P82(P05)/TO26 that are provided for the PWM outputs of the timer TOU0\_0–TOU0\_5. Similarly, the pin level ("H" or "L" level) on ports P110(P10)/TO29–P115(P15)/TO34 may be used to disable outputs from the ports P110(P10)/TO29–P115(P15)/TO34 that are provided for the PWM outputs of the timer TOU1\_0–TOU1\_5.

After detecting PWM output disable level from port P87(P00)/TO21–P82(P05)/TO26, P110(P10)/TO29–P115(P15)/TO34, PWM output is disabled. During PWM Output Disable, POnDISGmbit of PWM Output n Disable Control Gm Register is set to "1."

Restoring output enable status is done by exiting outputting PWM output disable level from port P87(P00)/TO21–P82(P05)/TO26, P110(P10)/TO29–P115(P15)/TO34 and then by "0" clearing POnDISGm bit of PWM Output n Disable Gm Register (POnDISGmCR).

Note: • If POnDISGmbit in PWM Output n Disable Control Gm Register is written during PWM Output Disable level outputting from port P87(P00)/TO21–P82(P05)/TO26, P110(P10)/TO29–P115(P15)/TO34, that operation of writing has no effect.

To disable PWM outputs using the pin level of ports, set up the PWM Output Disable Level Control Register (POnLVGACR, POnLVGBCR) and PWMOFF Function Enable Register (PWMOFFnEN) as described below.

**When using the P87(P00)/TO21–P82(P05)/TO26 port level to disable PWM outputs**

1. Using the PO0LVGACR(PO0LVGBCR) register PO0LVSELGA(PO0LVSELGB) bit, select the "H" or "L" level at which PWM output is to be disabled.
2. Set the PO0LVENGA(PO0LVENGB) bit to "1" (the selected output disable level effective).
3. Enable the PWMOFF0 function by writing "1" to either or both of the PWMOFF0GAEN and PWMOFF0GBEN bits of the PWMOFF0EN.

**When using the P110(P10)/TO29–P115(P15)/TO34 port level to disable PWM outputs**

1. Using the PO1LVGACR(PO1LVGBCR) register PO1LVSELGA(PO1LVSELGB) bit, select the "H" or "L" level at which PWM output is to be disabled.
2. Set the PO1LVENGA(PO1LVENGB) bit to "1" (the selected output disable level effective).
3. Enable the PWMOFF1 function by writing "1" to either or both of the PWMOFF1GAEN and PWMOFF1GBEN bits of the PWMOFF1EN.

### 10.8.21 Shorting Prevention Function

Before setting the shorting-prevention function enable/disable bit, be sure to stop the TOUn\_0 through TOUn\_5 counters. (Setting this bit while the timer is enabled for counting is prohibited.)

When the shorting-prevention function is enabled, make sure each timer is run in either of the following operation modes. (Using timers in any other modes is prohibited.)

TOUn\_0 (2, 4) Single-shot PWM mode  
 TOUn\_1 (3, 5) Single-shot output mode

When the shorting-prevention function is enabled, the TOUn enable source select bits of TOUn\_1 (3, 5) have no effect, so that these timers are invoked by an underflow of TOUn\_0 (2, 4).

Use the TOUn\_1 (3, 5) reload register to set the shorting-prevention time. At this time, note that the shorting-prevention time actually is the set value of the reload register + 3. The set value of the reload register must satisfy the condition given below.

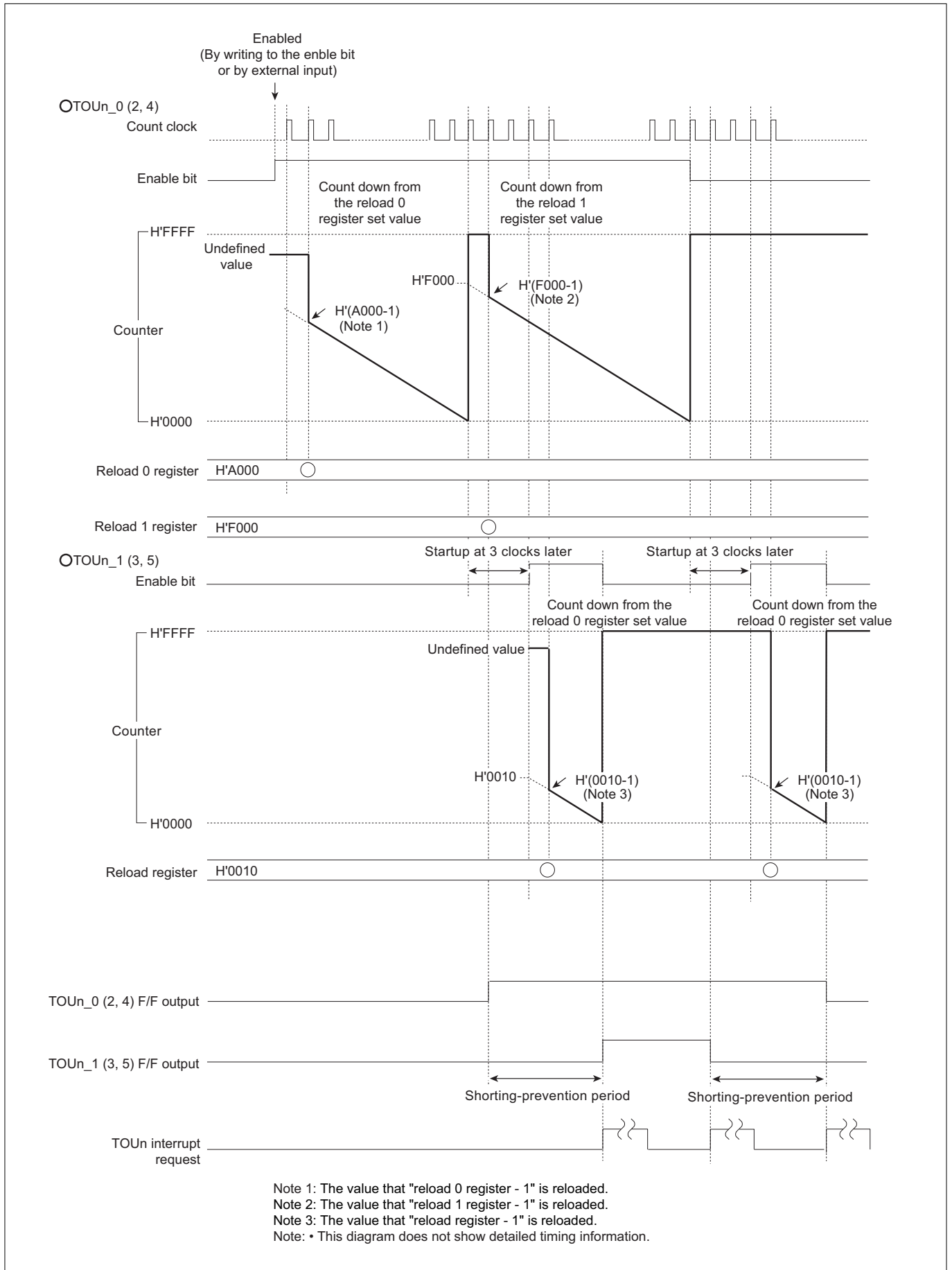
**Set value of the TOUn\_1 (3, 5) reload register  $\leq$  set value of the TOUn\_0 (2, 4) reload 1 register – 4**

Before the shorting-prevention function can be enabled, designated values must be set in the F/F data register and the F/F data register for the shorting-prevention function.

- **To output a "H" level signal first**  
Set a "1" in the F/F data register and a "0" in the F/F data register for the shorting-prevention function.
- **To output a "L" level signal first**  
Set a "0" in the F/F data register and a "1" in the F/F data register for the shorting-prevention function.

If the same value is set in the F/F data register and the F/F data register for the shorting-prevention function, a fixed-level signal is output.

When the shorting-prevention function is enabled, writing H'FFFF to the TOUn\_0 (2, 4) reload register 0 or the TOUn\_0 (2, 4) reload register 1 is prohibited.



**Figure 10.8.22 Schematic Operation of Shorting Prevention Function**

To enable the shorting-prevention function when it is necessary to forcibly fix output in software, follow the procedure described below.

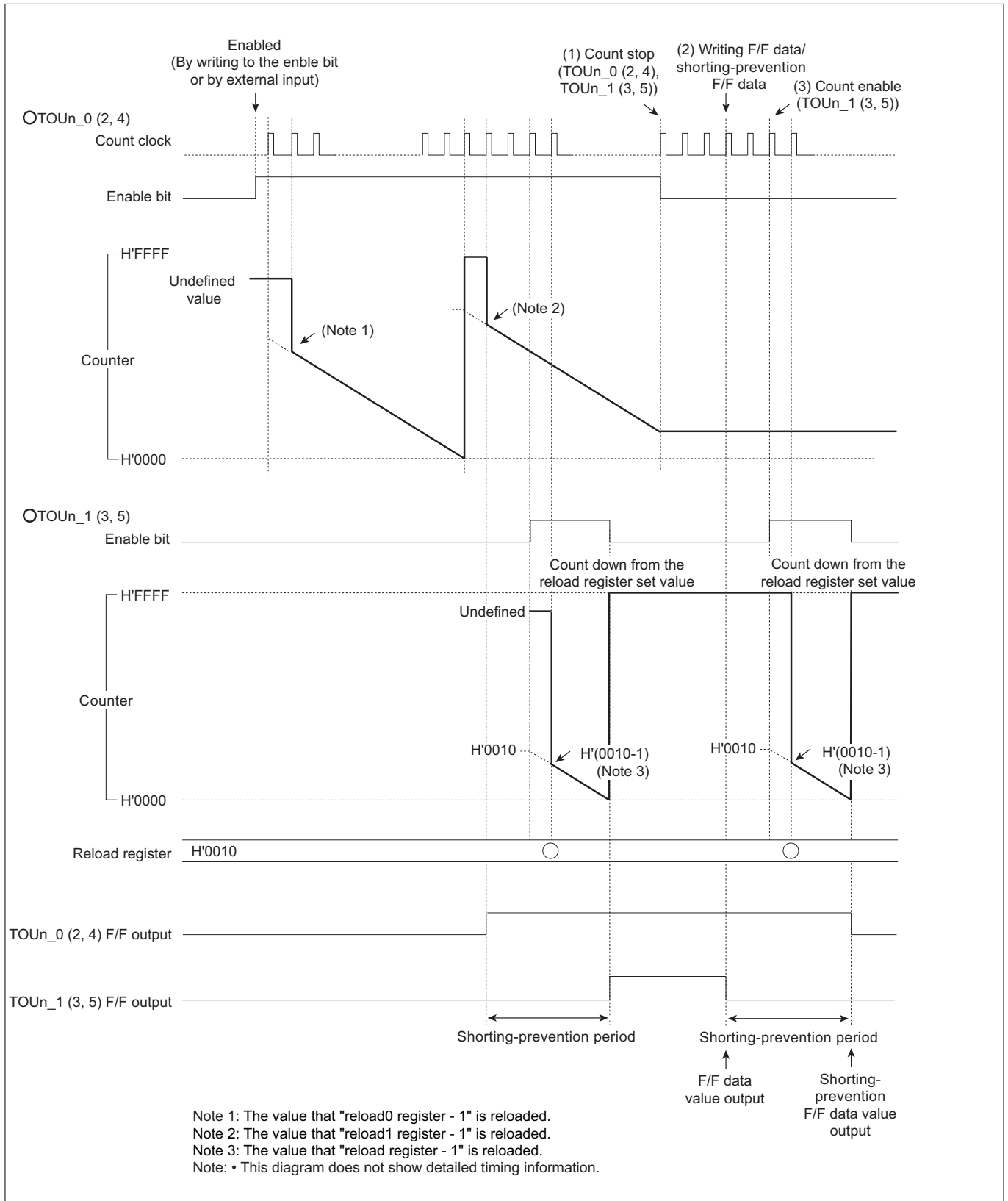
- (1) Write "0" to the TOUn\_0/1 (2/3, 4/5) count enable bit.
- (2) Set a "value to prevent shorting" in the F/F data register and a "value to be fixed" in the F/F data register for the shorting-prevention function.
- (3) Write "1" to the TOUn\_1 (3, 5) count enable bit.

In this case, the shorting-prevention time is as follows:

**Time before TOUn\_1 (3, 5) count is enabled after writing F/F data + TOUn\_1 (3, 5) reload register set value + 1**

To stop counters in software, make sure TOUn\_0/1 (2/3, 4/5) are made to stop counting at the same time. Stopping counters individually is prohibited.

Before writing "1" to the TOUn\_1 (3, 5) count enable bit, make sure TOUn\_0 (2, 4) and TOUn\_1 (3, 5) both have stopped counting.



**Figure 10.8.23 Schematic Operation for the Case Where the Output is Fixed Forcibly in Software**



#### 10.8.22 Example Application for Using the 32192/32195/32196 in Motor Control

The two-channel TOU timers incorporated in the 32192/32195/32196 help to reduce software burdens during motor control. The following shows an example application for using these timers in motor control.

The three-phase motor control waveform is produced by starting TOU in accordance with the fixed 20 kHz TOU startup timing generated by TID. The single-shot PWM function included in TOU enables any desired output waveform to be configured easily by storing waveform data only when the data needs to be rewritten. Note that the transistor shorting prevention time can be provided by changing the set time of TOU in software or using the shorting prevention function.

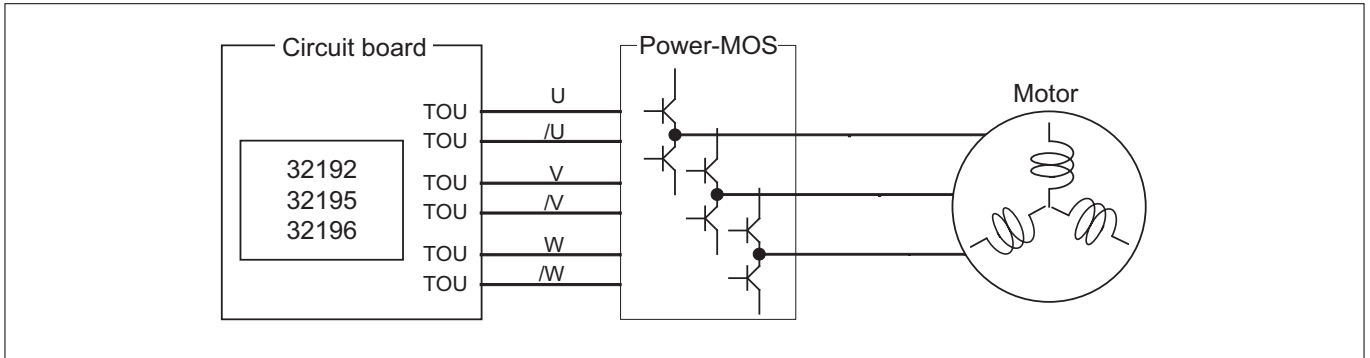


Figure 10.8.24 System Configuration Diagram

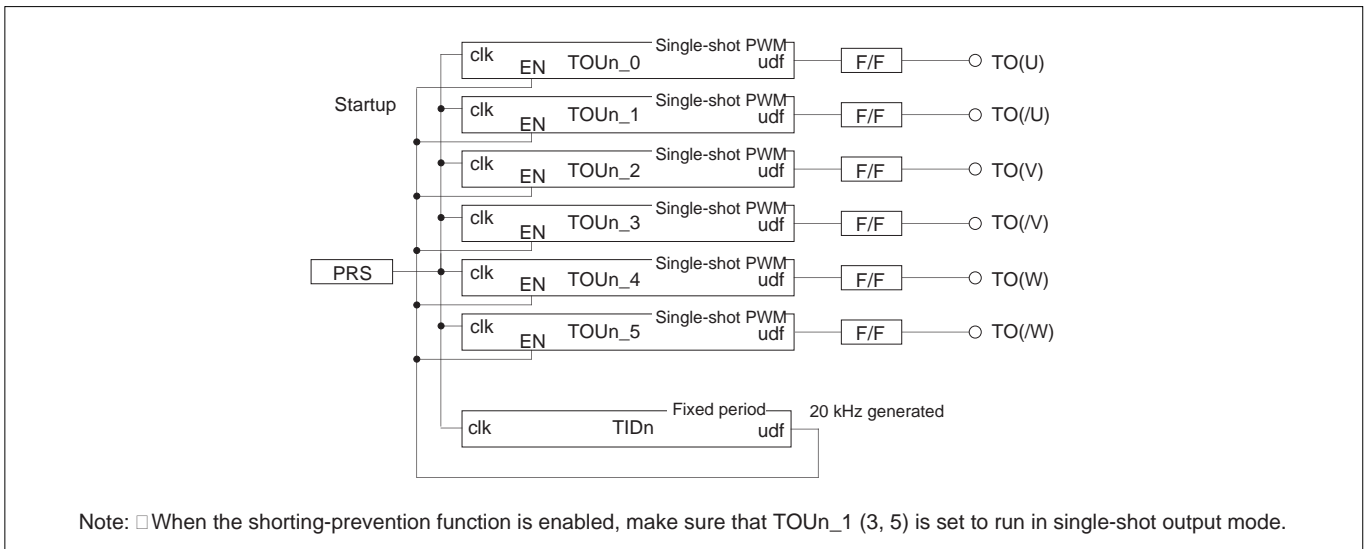


Figure 10.8.25 Timer Connections When Used for Three-Phase Motor Control

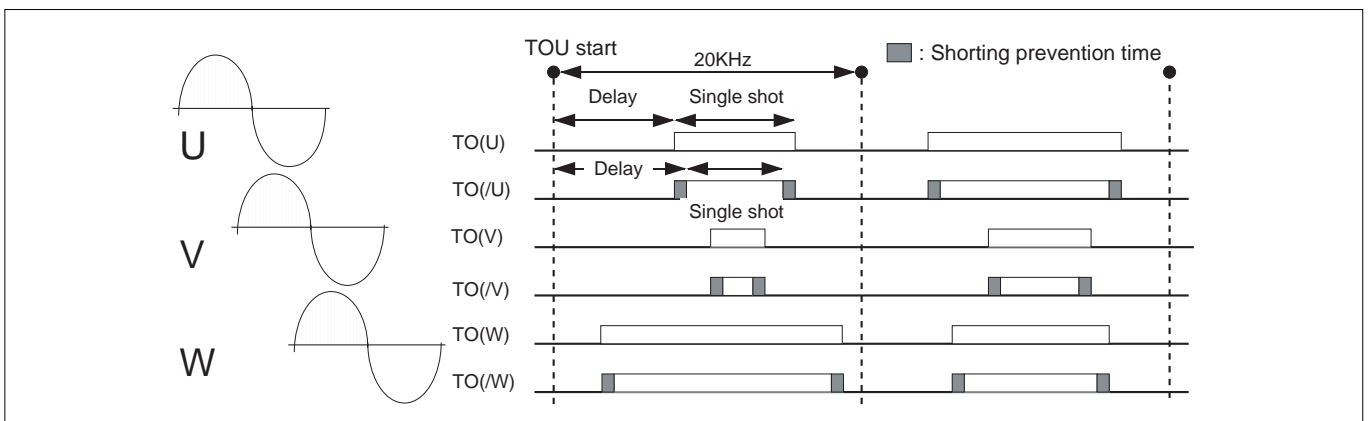


Figure 10.8.26 Conceptual Diagram of Motor Control

This page is blank for reasons of layout.

# **CHAPTER 11**

---

## **A/D CONVERTER**

- 11.1 Outline of A/D Converter
- 11.2 A/D Converter Related Registers
- 11.3 Functional Description of A/D Converter
- 11.4 Inflow Current Bypass Circuit
- 11.5 Notes on the A/D Converter

## 11.1 Outline of A/D Converter

The 32192/32195/32196 contains 10-bit resolution A/D Converter of the successive approximation type. The A/D converter has 16 analog input pins (channels) AD0IN0–AD0IN15. In addition to performing conversion individually on each channel, the A/D Converter can perform conversion successively on all of N channels (N = 1–16) as a single group. The conversion result can be read out in either 10 or 8 bits.

There are following conversion and operation modes for the A/D conversion:

### (1) Conversion Modes

- A/D conversion mode : Ordinary mode in which analog input voltages are converted into digital quantities.
- Comparator mode (Note 1) : A mode in which analog input voltage is compared with a preset comparison voltage to find only the relative magnitude of two quantities. (Useful in only single operation mode)

### (2) Operation Modes

- Single mode : Analog input voltage on one channel is A/D converted once or compared (Note 1) with a given quantity.
- Scan mode : Analog input voltages on two or more selected channels (in N channel units, N = 1–16) are sequentially A/D converted.
  - Single-shot scan mode : Scan operation is performed for one cycle.
  - Continuous scan mode : Scan operation is repeated until stopped.

### (3) Special Operation Modes

- Forcible single mode execution during scan mode : Conversion is forcibly executed in single mode (comparator mode) during scan operation.
- Scan mode start after single mode execution : Scan operation is started subsequently after executing conversion in single mode.
- Conversion restart : A/D conversion being executed in single or scan mode is restarted.

### (4) Sample-and-Hold Function

The analog input voltage is sampled when starting A/D conversion, and A/D conversion is performed on the sampled voltage. This function can be enabled or disabled as necessary.

### (5) Simultaneous Sampling Function

Two channels are sampled at the same time, and 2-channel continuous A/D conversion is able to be carried out for the sampled voltage.

### (6) A/D Disconnection Detection Assist Function

To suppress influences of the analog input voltage leakage from any preceding channel during scan mode operation, a function is incorporated that helps to fix the electric charge on the chopper amp capacitor to the given state (AVCC0 or GND) before starting A/D conversion. This function provides a sure and reliable means of detecting a disconnection in the wiring patterns connecting to the analog input pins.

**(7) Inflow Current Bypass Circuit**

If an overvoltage or negative voltage is applied to any analog input channel which is currently inactive, a current flows into or out of the analog input channel currently being A/D converted via the internal circuit, causing the conversion accuracy to degrade. To solve this problem, the A/D Converter incorporates a circuit that bypasses such inflow current. This circuit is always enabled.

**(8) Conversion Speed**

The A/D conversion speed is shown in Table 11.1.1 below. The A/D conversion speed is decided by selecting combination such as with or without Sample-and-Hold and selecting Normal or Fast Sample-and-Hold, selecting Slow or Fast mode, selecting Normal or Double speed. Conversion speed of comparator mode is decided by selecting combination such as selecting Slow or Fast mode, selecting Normal or Double speed.

**(9) Interrupt Request and DMA Transfer Request Generation Functions**

An A/D conversion interrupt or DMA transfer request can be generated each time A/D conversion (single mode operation, single-shot scan operation or one cycle of continuous operation) or compare operation is completed.

Note 1: To discriminate between the comparison performed internally by the successive approximation-type A/D Converter and that performed in comparator mode using the same A/D Converter as a comparator, the comparison in comparator mode is referred to in this manual as “compare.”

Table 11.1.1 outlines the A/D Converter and Figure 11.1.1 shows block diagram of A/D Converter.

**Table 11.1.1 Outline of the A/D Converter (1/2)**

Item	Description			
Analog input	16 channels x 1			
A/D conversion method	Successive approximation method			
Resolution	10 bits (Conversion result can be read out in either 8 or 10 bits)			
Absolute accuracy (Note 1) (Note 2)	Sample-and-hold is disabled	Slow mode	Normal speed	$\pm 2\text{LSB}$
			Double speed	$\pm 2\text{LSB}$
		Fast mode	Normal speed	$\pm 3\text{LSB}$
			Double speed	$\pm 3\text{LSB}$
	Normal Sample-and-hold is enabled, Simultaneous sampling is disabled	Slow mode	Normal speed	$\pm 2\text{LSB}$
			Double speed	$\pm 2\text{LSB}$
		Fast mode	Normal speed	$\pm 3\text{LSB}$
			Double speed	$\pm 3\text{LSB}$
	Fast Sample-and-hold is enabled, Simultaneous sampling is disabled	Slow mode	Normal speed	$\pm 3\text{LSB}$
			Double speed	$\pm 3\text{LSB}$
		Fast mode	Normal speed	$\pm 3\text{LSB}$
			Double speed	$\pm 8\text{LSB}$
	Normal Sample-and-hold is enabled, Simultaneous sampling is enabled	Slow mode	Normal speed	$\pm 3\text{LSB}$
			Double speed	$\pm 3\text{LSB}$
		Fast mode	Normal speed	$\pm 3\text{LSB}$
			Double speed	$\pm 3\text{LSB}$
Fast Sample-and-hold is enabled, Simultaneous sampling is enabled	Slow mode	Normal speed	$\pm 3\text{LSB}$	
		Double speed	$\pm 3\text{LSB}$	
	Fast mode	Normal speed	$\pm 3\text{LSB}$	
		Double speed	$\pm 8\text{LSB}$	

Table 11.1.1 Outline of the A/D Converter (2/2)

Item	Description					
Conversion mode	A/D Conversion, comparator mode					
Operation mode	Single mode, Scan one shot mode, Scan continuous mode					
Conversion start trigger	Software start	Started by setting the A/D conversion start bit to "1"				
	Hardware start	A/D0 Converter	MJT (input event bus 2), MJT (input event bus 3), MJT (output event bus 3) and MJT (TIN23)			
Conversion speed (Note 1) (Note 2)	During single mode (When sample-and-hold disabled/ When normal sample-and-hold enabled)	Slow mode	Normal speed	598 x BCLK	14.95μs	
			Double speed	346 x BCLK	8.65μs	
		Fast mode	Normal speed	262 x BCLK	6.55μs	
			Double speed	178 x BCLK	4.45μs	
	During single mode (When fast sample-and-hold enabled)	Slow mode	Normal speed	382 x BCLK	9.55μs	
			Double speed	202 x BCLK	5.05μs	
		Fast mode	Normal speed	190 x BCLK	4.75μs	
			Double speed	106 x BCLK	2.65μs	
	During comparator mode	Slow mode	Normal speed	94 x BCLK	2.35μs	
			Double speed	58 x BCLK	1.45μs	
		Fast mode	Normal speed	46 x BCLK	1.15μs	
			Double speed	34 x BCLK	0.85μs	
Sample-and-hold function	Sample-and-hold function can be enabled or disabled as necessary.					
Simultaneous sampling function	When Sample-and-hold function is effective, 2 channel simultaneous sampling function can be selected.					
A/D disconnection assist function	Influences of the analog input voltage leakage from any preceding channel during scan detection mode operation are suppressed.					
Interrupt request generation function	Generated when A/D conversion (single mode operation, single-shot scan operation or one cycle of continuous operation) or compare operation is completed.					
DMA transfer request generation function	Generated when A/D conversion (single mode operation, single-shot scan operation or one cycle of continuous operation) or compare operation is completed.					

Note 1: Condition for standard value :  $f(XIN)=20\text{MHz}$ ,  $V_{CC0}=V_{CCBUS}=V_{DDE}=V_{AVCC0}=5.12\text{V}$ ,  $V_{CCER}=3.3\text{V}\pm 0.3\text{V}$ ,  $T_a=-40^\circ\text{C}$  to  $+105^\circ\text{C}$ , 2BCLK mode

Note 2: The conversion accuracy stipulated here refers to that of the microcomputer alone, with influences of the power supply wiring and noise on the board not taken into account.

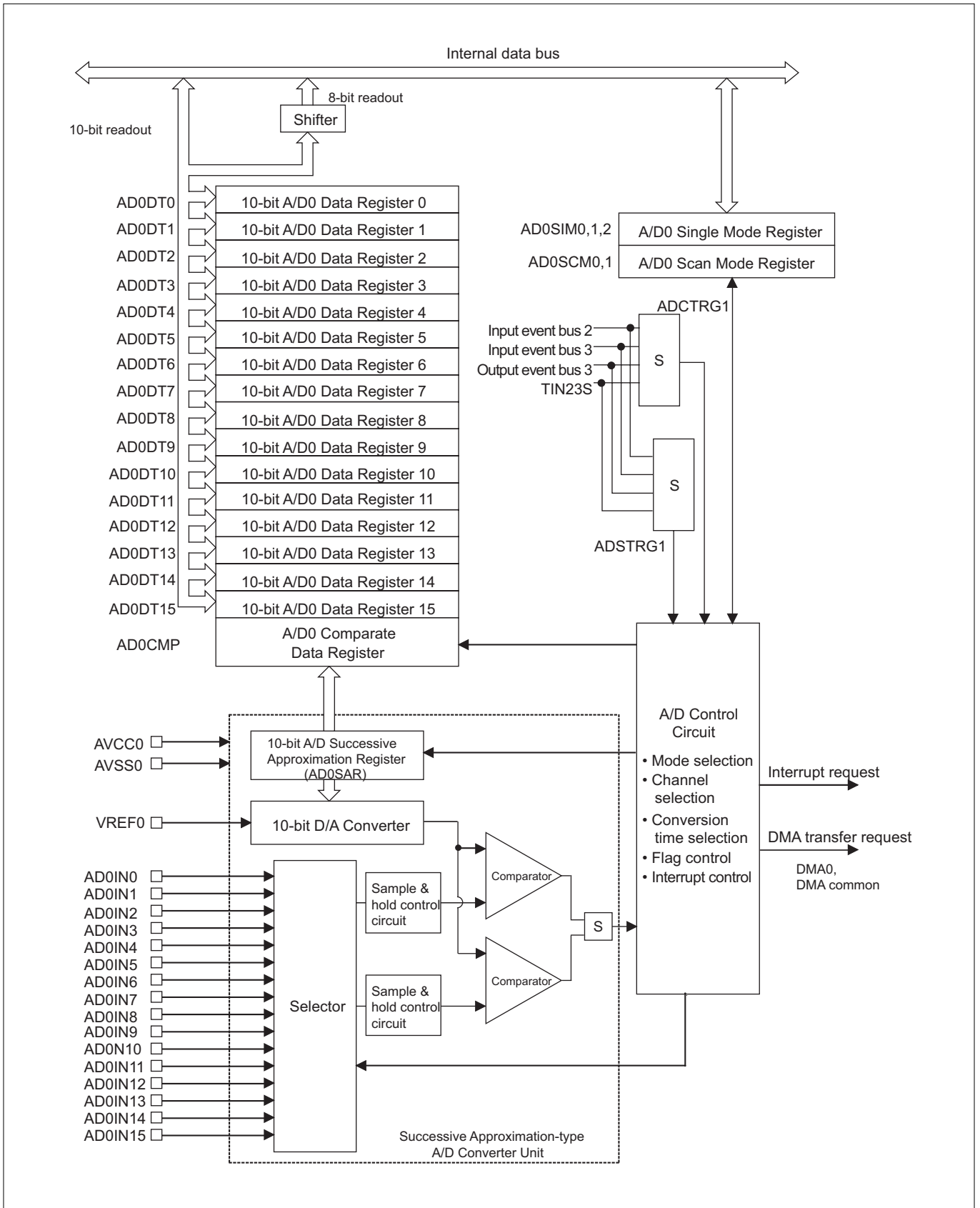


Figure 11.1.1 Block Diagram of the A/D Converter

### 11.1.1 Conversion Modes

The A/D Converter has two conversion modes: "A/D Conversion mode" and "Comparator mode."

#### (1) A/D Conversion Mode

In A/D conversion mode, the analog input voltage on a specified channel is A/D converted.

In single mode, A/D conversion is performed on a channel selected by the A/D Single Mode Register 1 analog input pin select bit.

In scan mode, A/D conversion is performed on channels selected by A/D Scan Mode Register 1 according to settings of A/D Scan Mode Register 0.

The conversion result is stored in each channel's corresponding 10-bit A/D Data Register. There is also an 8-bit A/D Data Register for each channel, from which 8-bit A/D conversion results can be read out.

An A/D conversion interrupt or DMA transfer request can be generated when A/D conversion in single mode is completed, as well as when one cycle of scan loop in scan mode is completed.

#### (2) Comparator Mode

In comparator mode, the analog input voltage on a specified channel is "compared" (compared) with the successive approximation register value, and the result (relative magnitude of two values) is returned to a flag.

The channel to be compared is selected using the A/D Single Mode Register 1 analog input pin select bit.

The result of compare operation is flagged ("0" or "1") by setting the A/D Compare Data Register bit that corresponds to the selected channel.

An A/D conversion interrupt or DMA transfer request can be generated when compare operation is completed.

### 11.1.2 Operation Modes

There are two operation modes for the A/D Converter: "Single mode" and "Scan mode." When comparator mode is selected as A/D conversion mode, only single mode can be used.

#### (1) Single Mode

In single mode, the analog input voltage on one selected channel is A/D converted or compared once. An A/D conversion interrupt or DMA transfer request can be generated when A/D conversion or compare operation is completed.

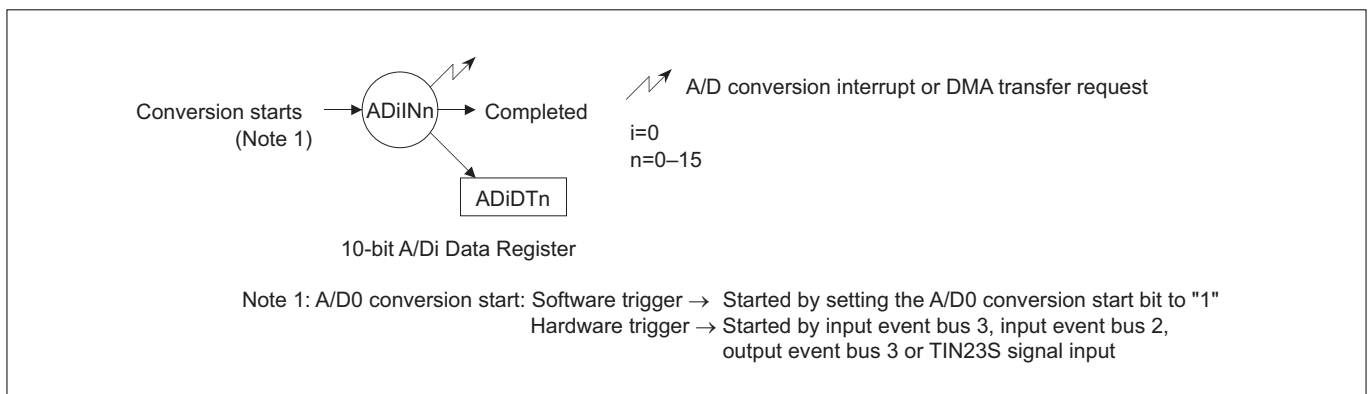
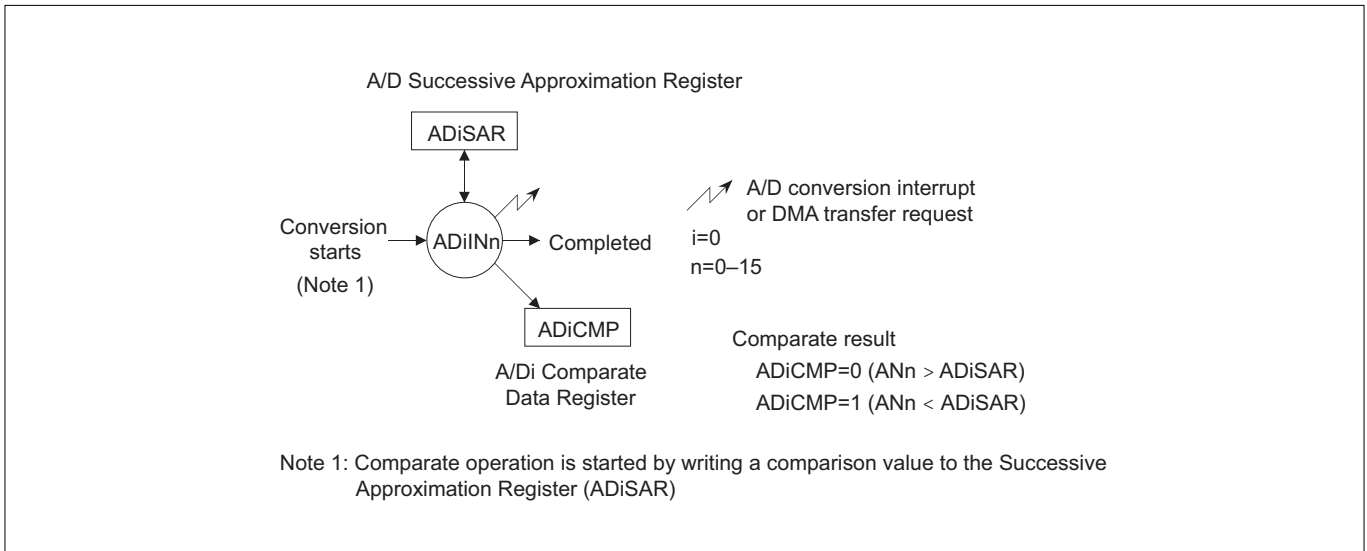


Figure 11.1.2 Operation in Single Mode (A/D Conversion)





**Figure 11.1.3 Operation in Single Mode (Compare)**

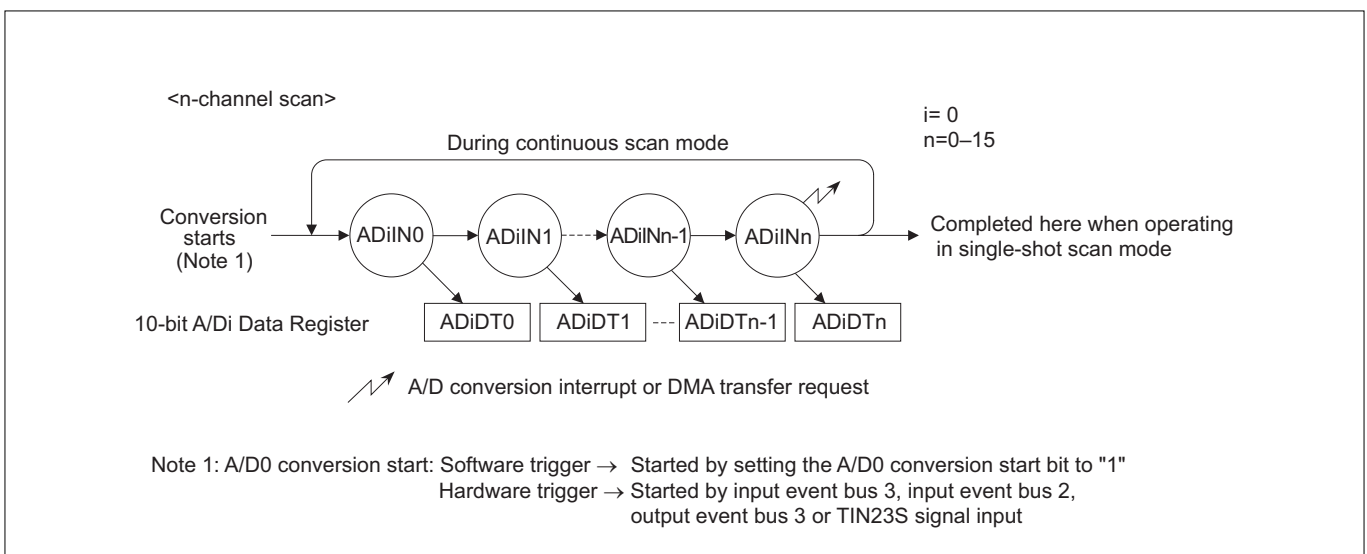
#### (2) Scan Mode

In scan mode, the analog input voltages from channel 0 to the channel selected by the A/D Scan Mode Register 1 scan loop select bit (channels 0–15) are sequentially A/D converted.

There are two types of scan mode: “Single-shot scan mode” in which A/D conversion is completed after performing one cycle of scan operation, and “Continuous scan mode” in which scan operation is continued until halted by setting the A/D scan mode register 0’s A/D conversion stop bit to “1.”

These types of scan mode are selected using A/D Scan Mode Register 0. The channels to be scanned are selected using A/D Scan Mode Register 1. The selected channels are scanned sequentially beginning with channel 0.

An A/D conversion interrupt or DMA transfer request can be generated when one cycle of scan operation is completed.



**Figure 11.1.4 Operation of A/D Conversion in Scan Mode**

Table 11.1.2 Registers in Which Scan Mode A/D Conversion Results Are Stored

Scan Mode Register 1 channel selection	Selected channels for single-shot scan	Selected channels for continuous scan	A/D conversion result storage register
B'0000:0 (ADiIN0)	ADiIN0	ADiIN0	10-bit A/Di Data Register 0
	Completed	ADiIN0	10-bit A/Di Data Register 0
		∴ (Repeated until forcibly terminated)	∴
B'0001:1 (ADiIN1)	ADiIN0	ADiIN0	10-bit A/Di Data Register 0
	ADiIN1	ADiIN1	10-bit A/Di Data Register 1
	Completed	ADiIN0	10-bit A/Di Data Register 0
		∴ (Repeated until forcibly terminated)	∴
B'0010:2 (ADiIN2)	ADiIN0	ADiIN0	10-bit A/Di Data Register 0
	ADiIN1	ADiIN1	10-bit A/Di Data Register 1
	ADiIN2	ADiIN2	10-bit A/Di Data Register 2
	Completed	ADiIN0	10-bit A/Di Data Register 0
		∴ (Repeated until forcibly terminated)	∴
B'0011:3 (ADiIN3)	ADiIN0	ADiIN0	10-bit A/Di Data Register 0
	ADiIN1	ADiIN1	10-bit A/Di Data Register 1
	ADiIN2	ADiIN2	10-bit A/Di Data Register 2
	ADiIN3	ADiIN3	10-bit A/Di Data Register 3
	Completed	ADiIN0	10-bit A/Di Data Register 0
		∴ (Repeated until forcibly terminated)	∴
B'XXXX:n (ADiINn)  n≤15	ADiIN0	ADiIN0	10-bit A/Di Data Register 0
	ADiIN1	ADiIN1	10-bit A/Di Data Register 1
	ADiIN2	ADiIN2	10-bit A/Di Data Register 2
		∴	∴
	ADiINn	ADiINn	10-bit A/Di Data Register n
Completed	ADiIN0	10-bit A/Di Data Register 0	
	∴ (Repeated until forcibly terminated)	∴	

(i=0)

#### 11.1.3 Special Operation Modes

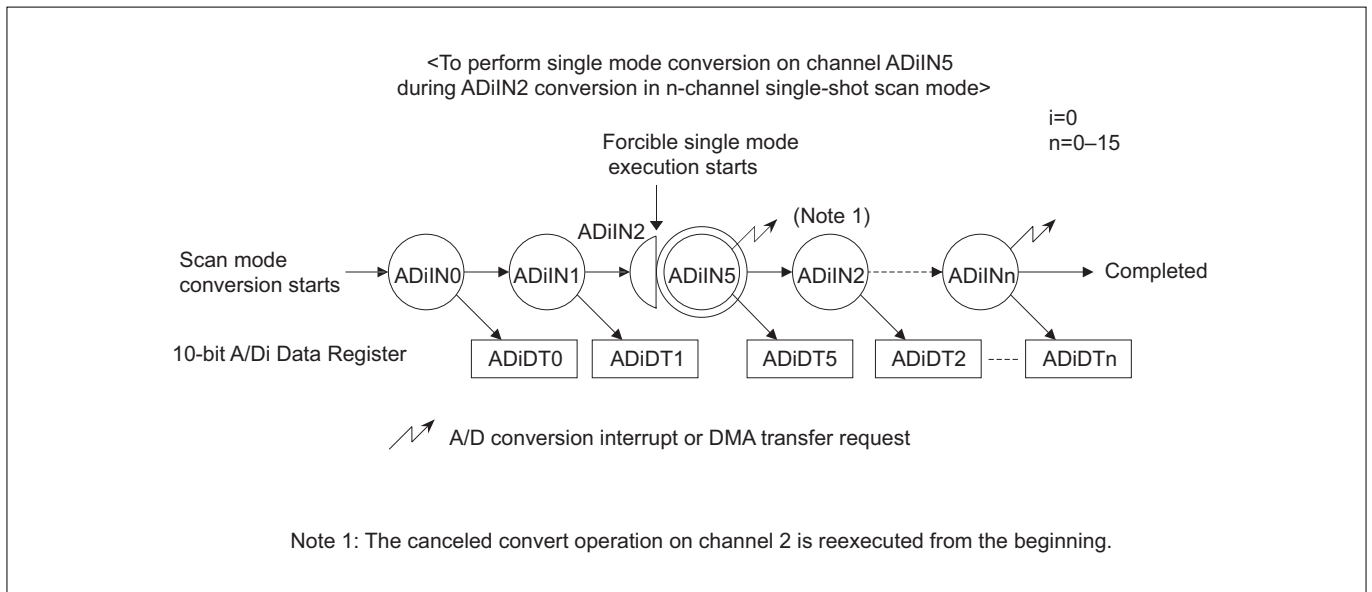
##### (1) Forcible single mode execution during scan mode

In this special operation mode, single mode conversion (A/D conversion or compare) is forcibly executed on a specified channel during scan mode operation. For A/D conversion mode, the conversion result is stored in the A/D Data Register corresponding to the specified channel, whereas for compare mode, the comparison result is stored in the 10-bit A/D Compare Data Register. When the A/D conversion or compare operation on a specified channel finishes, scan mode A/D conversion is restarted from where it was canceled during scan operation.

To start single mode conversion during scan mode operation in software, choose a software trigger using the Single Mode Register 0 A/D conversion start trigger select bit. Then, for A/D conversion, set the said register's A/D conversion start bit to "1." For compare mode, write a comparison value to the A/D Successive Approximation Register (AD0SAR) during scan mode operation.

To start single mode conversion during scan mode operation in hardware, choose a hardware trigger using the Single Mode Register 0 A/D conversion start trigger select bit. Then enter the hardware trigger selected with the said register.

An A/D conversion interrupt or DMA transfer request can be generated when conversion on a specified channel or one cycle of scan operation is completed.



**Figure 11.1.5 Forcible Single Mode Execution during Scan Mode**

**(2) Scan mode start after single mode execution**

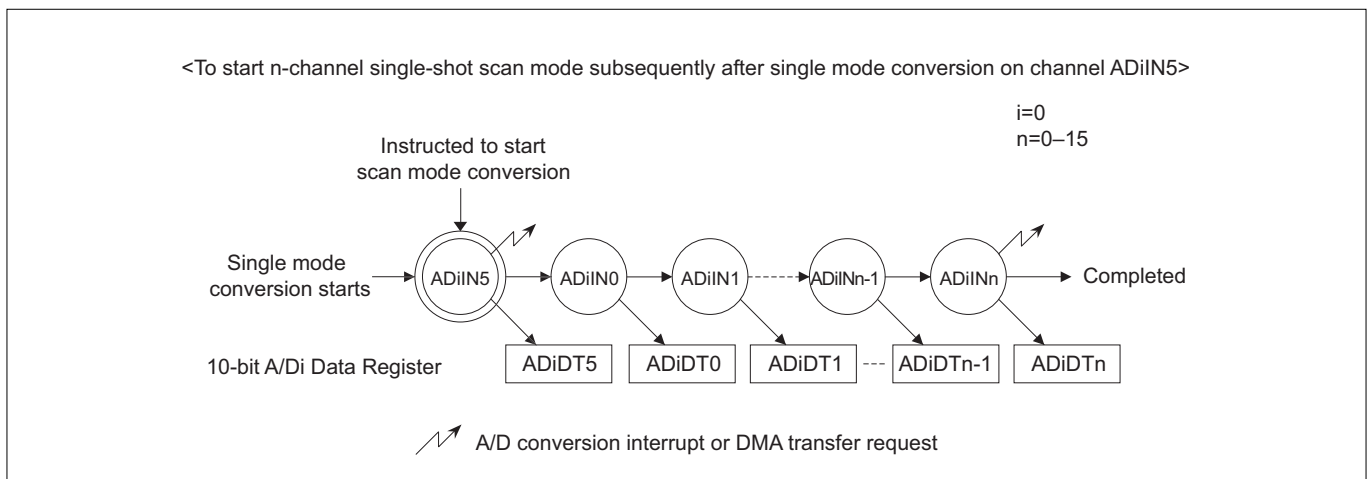
In this special operation mode, scan operation is started subsequently after executing single mode conversion (A/D conversion or compare).

To start this mode in software, choose a software trigger using the A/D Scan Mode Register 0 A/D conversion start trigger select bit. Then set the said register's A/D conversion start bit to "1" during single mode conversion operation.

To start this mode in hardware, choose a hardware trigger using the A/D Scan Mode Register 0 A/D conversion start trigger select bit. Then enter the hardware trigger selected with the said register during single mode conversion operation.

If a hardware trigger is selected using the A/D conversion start trigger select bit in both A/D Single Mode Register 0 and A/D Scan Mode Register 0 and the selected hardware triggers are entered, the A/D Converter first performs single mode conversion and then scan mode conversion in succession.

An A/D conversion interrupt or DMA transfer request can be generated when single mode conversion on a specified channel or one cycle of scan operation is completed.



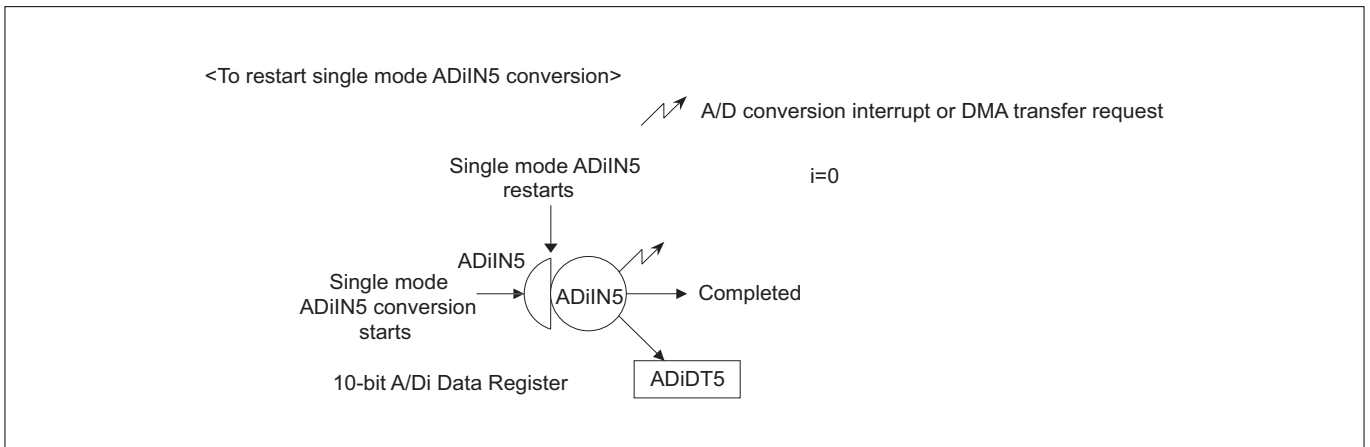
**Figure 11.1.6 Scan Mode Start after Single Mode Execution**

#### (3) Conversion restart

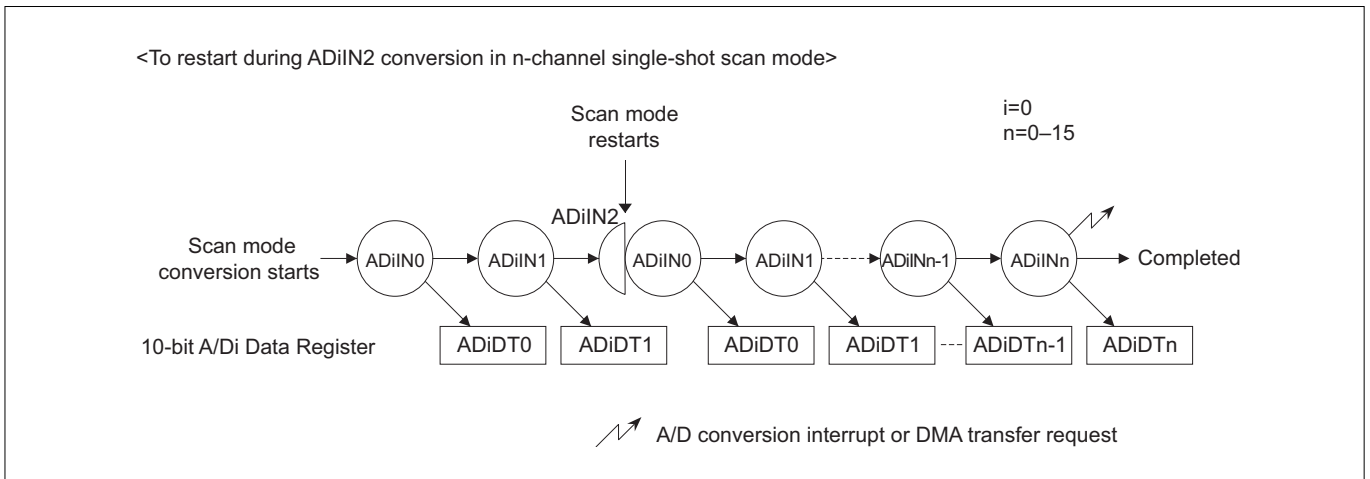
In this special operation mode, operation being executed in single or scan mode is stopped in the middle and reexecuted from the beginning.

When in single mode, set the A/D Single Mode Register 0 A/D conversion start bit to "1" again or enter a hardware trigger during A/D conversion or compare operation, and the operation being executed is restarted over again.

When in scan mode, set the A/D Scan Mode Register 0 A/D conversion start bit to "1" again or enter a hardware trigger signal during scan operation, and the channel being converted is canceled and A/D conversion is performed from channel 0 over again.



**Figure 11.1.7 Conversion Restart during Single Mode Operation**



**Figure 11.1.8 Conversion Restart during Scan Operation**

### 11.1.4 A/D Converter Interrupt and DMA Transfer Requests

The A/D Converter can generate an A/D conversion interrupt or DMA transfer request each time A/D conversion (single mode operation, single-shot scan operation or one cycle of continuous operation) or compare operation is completed. The A/D Single Mode Register 0 and A/D Scan Mode Register 0 are used to select between A/D conversion interrupt and DMA transfer requests.

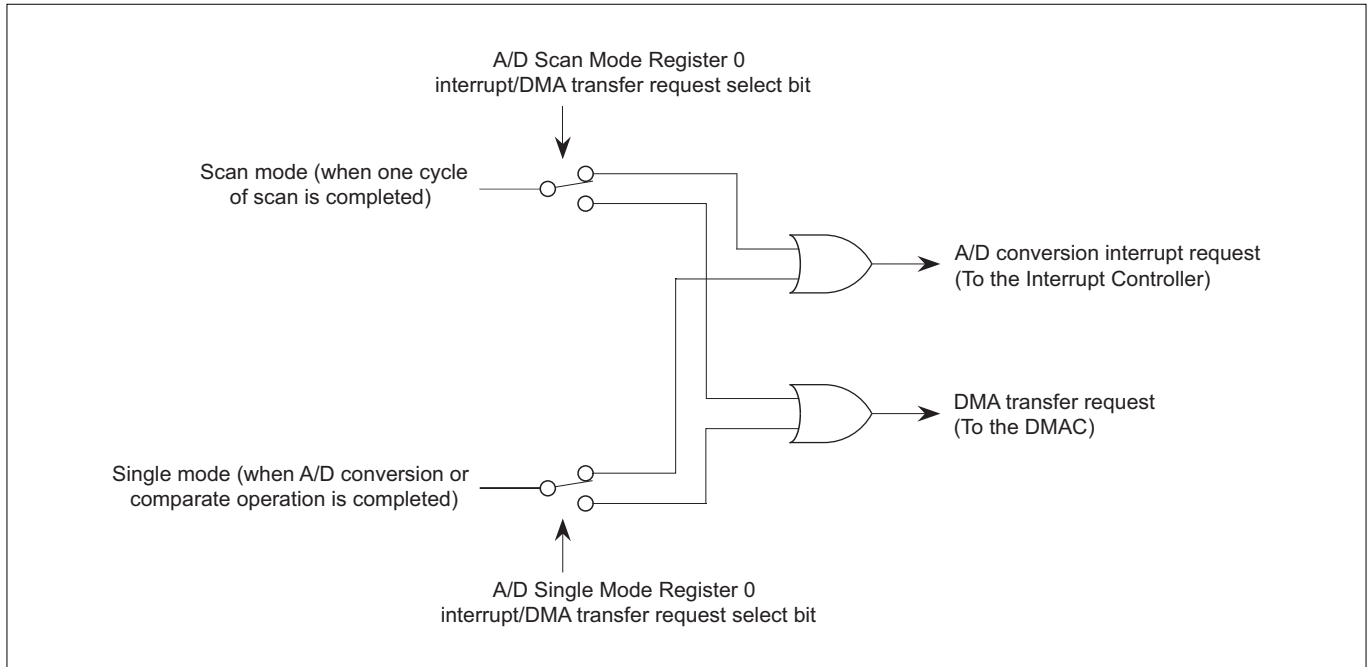


Figure 11.1.9 Selecting between Interrupt and DMA Transfer Requests

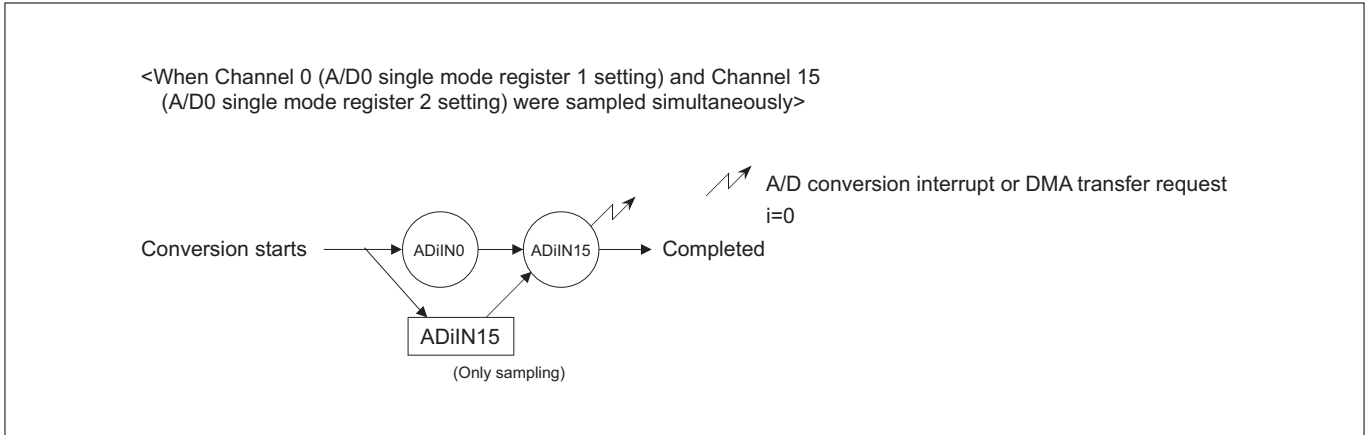
### 11.1.5 Sample-and-Hold Function

The analog input voltage that was sampled immediately after A/D conversion started is held on, and A/D conversion is performed on that seized voltage.

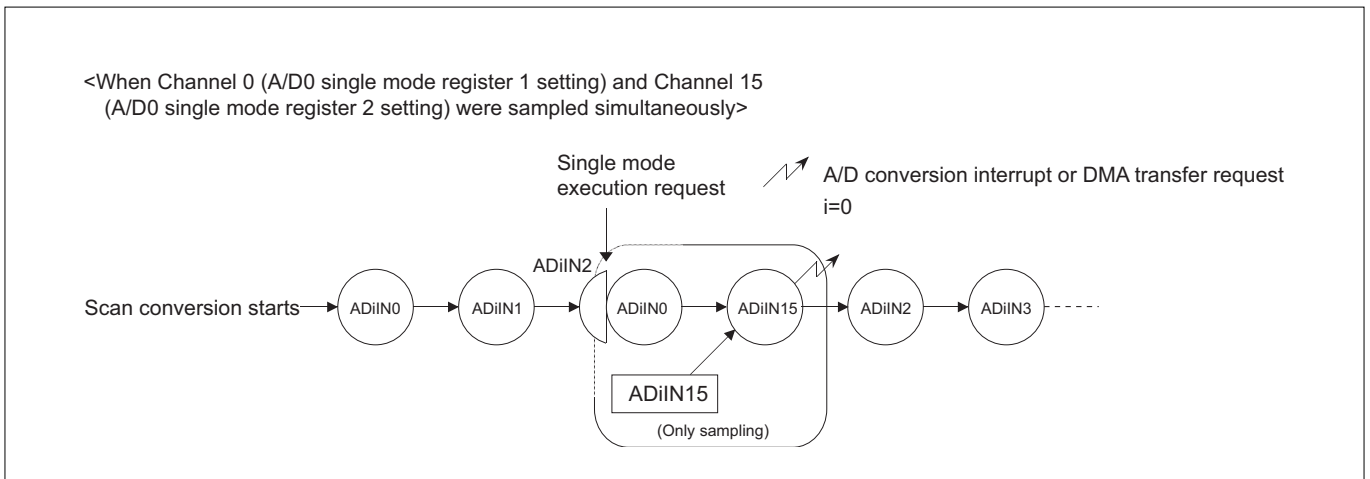
The A/D conversion time in “normal” sample-and-hold mode is the same as in conventional A/D conversion mode of the 32170, etc. The A/D conversion time in “fast” sample-and-hold mode is significantly short, allowing to obtain conversion results more quickly than ever.

#### 11.1.6 Simultaneous Sampling Function

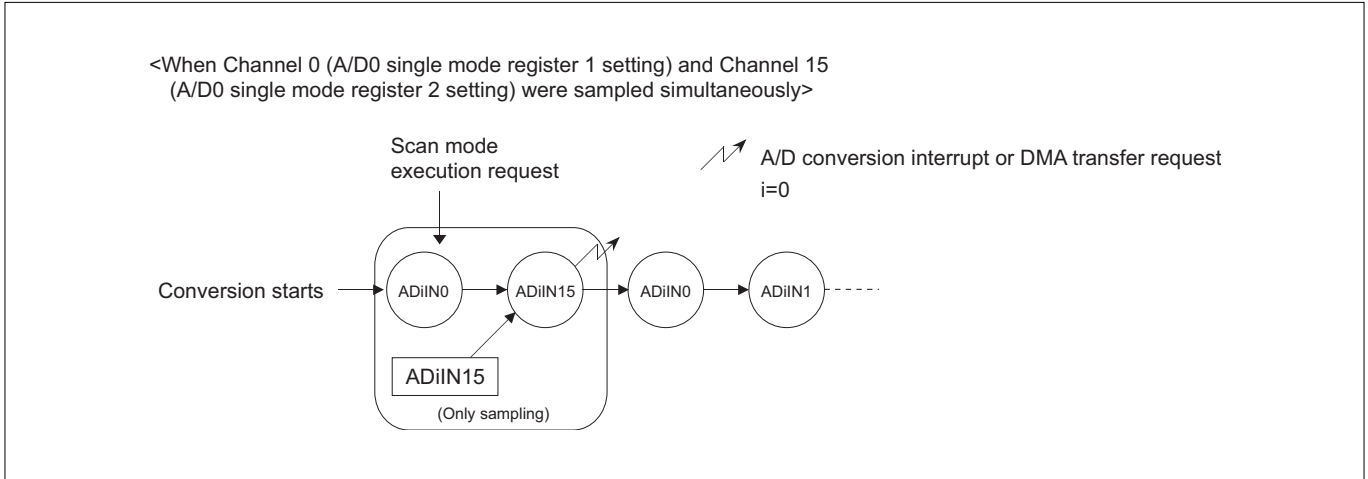
When the sample-and-hold function is effective, 2 channel Simultaneous Sampling Function can be used, and A/D conversion is carried out with 2-channel continually for the sampled voltage.



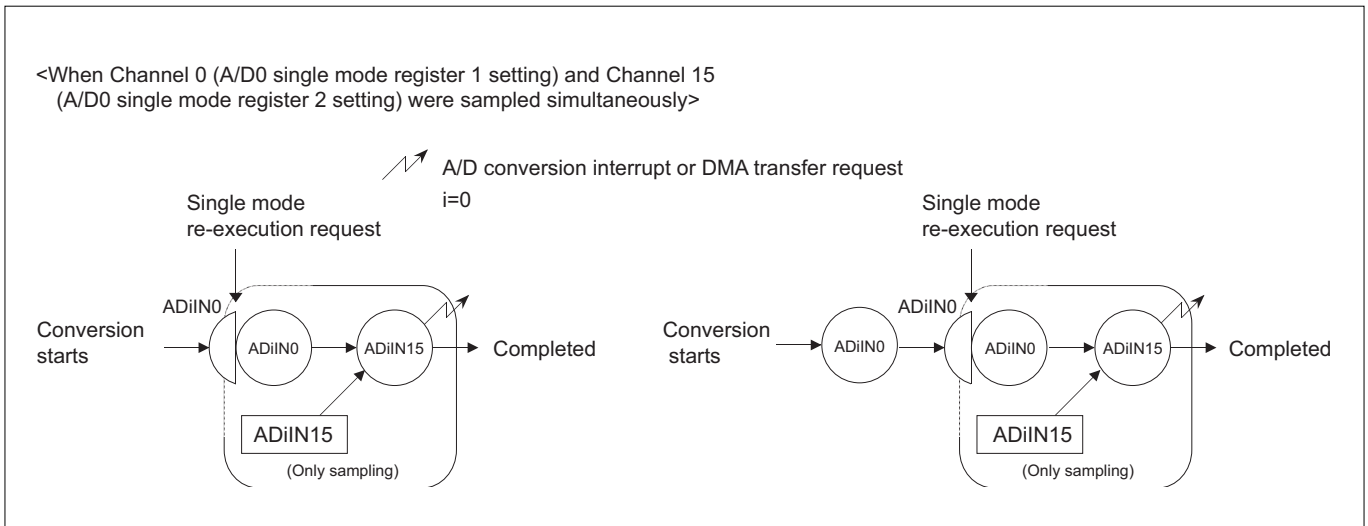
**Figure 11.1.10 Single Mode when Simultaneous Sampling is Effective**



**Figure 11.1.11 Forcible Single Mode Execution during Scanning when Simultaneous Sampling is Effective**



**Figure 11.1.12 Scanning Start after Single Mode Execution when Simultaneous Sampling is Effective**



**Figure 11.1.13 Single Mode Restart when Simultaneous Sampling is Effective**



## 11.2 A/D Converter Related Registers

Shown below is an A/D converter related register map.

A/D Converter Related Register Map (1/2)

Address	+0 address		+1 address		See pages
	b0	b7	b8	b15	
H'0080 0080	A/D0 Single Mode Register 0 (AD0SIM0)		A/D0 Single Mode Register 1 (AD0SIM1)		11-17 11-19
H'0080 0082	(Use inhibited area)		A/D0 Single Mode Register 2 (AD0SIM2)		11-21
H'0080 0084	A/D0 Scan Mode Register 0 (AD0SCM0)		A/D0 Scan Mode Register 1 (AD0SCM1)		11-22 11-24
H'0080 0086	A/D0 Disconnection Detection Assist Function Control Register (AD0DDACR)		A/D0 Conversion Speed Control Register (AD0CVSCR)		11-27 11-26
H'0080 0088	A/D0 Successive Approximation Register (AD0SAR)				11-31
H'0080 008A	A/D0 Disconnection Detection Assist Method Select Register (AD0DDASEL)				11-28
H'0080 008C	A/D0 Compare Data Register (AD0CMP)				11-32
H'0080 008E	(Use inhibited area)				
H'0080 0090	10-bit A/D0 Data Register 0 (AD0DT0)				11-33
H'0080 0092	10-bit A/D0 Data Register 1 (AD0DT1)				11-33
H'0080 0094	10-bit A/D0 Data Register 2 (AD0DT2)				11-33
H'0080 0096	10-bit A/D0 Data Register 3 (AD0DT3)				11-33
H'0080 0098	10-bit A/D0 Data Register 4 (AD0DT4)				11-33
H'0080 009A	10-bit A/D0 Data Register 5 (AD0DT5)				11-33
H'0080 009C	10-bit A/D0 Data Register 6 (AD0DT6)				11-33
H'0080 009E	10-bit A/D0 Data Register 7 (AD0DT7)				11-33
H'0080 00A0	10-bit A/D0 Data Register 8 (AD0DT8)				11-33
H'0080 00A2	10-bit A/D0 Data Register 9 (AD0DT9)				11-33
H'0080 00A4	10-bit A/D0 Data Register 10 (AD0DT10)				11-33
H'0080 00A6	10-bit A/D0 Data Register 11 (AD0DT11)				11-33
H'0080 00A8	10-bit A/D0 Data Register 12 (AD0DT12)				11-33
H'0080 00AA	10-bit A/D0 Data Register 13 (AD0DT13)				11-33
H'0080 00AC	10-bit A/D0 Data Register 14 (AD0DT14)				11-33
H'0080 00AE	10-bit A/D0 Data Register 15 (AD0DT15)				11-33
	(Use inhibited area)				
H'0080 00D0	(Use inhibited area)		8-bit A/D0 Data Register 0 (AD08DT0)		11-34
H'0080 00D2	(Use inhibited area)		8-bit A/D0 Data Register 1 (AD08DT1)		11-34
H'0080 00D4	(Use inhibited area)		8-bit A/D0 Data Register 2 (AD08DT2)		11-34
H'0080 00D6	(Use inhibited area)		8-bit A/D0 Data Register 3 (AD08DT3)		11-34
H'0080 00D8	(Use inhibited area)		8-bit A/D0 Data Register 4 (AD08DT4)		11-34
H'0080 00DA	(Use inhibited area)		8-bit A/D0 Data Register 5 (AD08DT5)		11-34
H'0080 00DC	(Use inhibited area)		8-bit A/D0 Data Register 6 (AD08DT6)		11-34

## A/D Converter Related Register Map (2/2)

Address	+0 address		+1 address		See pages
	b0	b7	b8	b15	
H'0080 00DE	(Use inhibited area)		8-bit A/D0 Data Register 7 (AD08DT7)		11-34
H'0080 00E0	(Use inhibited area)		8-bit A/D0 Data Register 8 (AD08DT8)		11-34
H'0080 00E2	(Use inhibited area)		8-bit A/D0 Data Register 9 (AD08DT9)		11-34
H'0080 00E4	(Use inhibited area)		8-bit A/D0 Data Register 10 (AD08DT10)		11-34
H'0080 00E6	(Use inhibited area)		8-bit A/D0 Data Register 11 (AD08DT11)		11-34
H'0080 00E8	(Use inhibited area)		8-bit A/D0 Data Register 12 (AD08DT12)		11-34
H'0080 00EA	(Use inhibited area)		8-bit A/D0 Data Register 13 (AD08DT13)		11-34
H'0080 00EC	(Use inhibited area)		8-bit A/D0 Data Register 14 (AD08DT14)		11-34
H'0080 00EE	(Use inhibited area)		8-bit A/D0 Data Register 15 (AD08DT15)		11-34

## 11.2.1 A/D Single Mode Register 0

A/D0 Single Mode Register 0 (AD0SIM0)

&lt;Address: H'0080 0080&gt;

b0	1	2	3	4	5	6	b7
ADSTRG1		ADSTRG0	ADSSEL	ADSREQ	ADSCMP	ADSSTP	ADSSTT
0	0	0	0	0	1	0	0

&lt;Upon exiting reset: H'04&gt;

b	Bit Name	Function	R	W
0	ADSTRG1 (Note 1) A/D hardware trigger select 1 bit	Bits 0 and 2 are used to select an A/D hardware trigger. b0 b2 0 0 : Input event bus 2 0 1 : Input event bus 3 1 0 : Output event bus 3 1 1 : TIN23S signal	R	W
1	No function assigned. Fix to "0."		0	0
2	ADSTRG0 (Note 1) A/D hardware trigger select 0 bit	Bits 0 and 2 are used to select an A/D hardware trigger. (See the column for bit 0.)	R	W
3	ADSSEL A/D conversion start trigger select bit	0: Software trigger 1: Hardware trigger (Note 2)	R	W
4	ADSREQ A/D Interrupt/DMA transfer request select bit	0: A/D conversion interrupt request 1: DMA transfer request	R	W
5	ADSCMP A/D conversion/comparate completed bit	0: A/D conversion/comparate in progress 1: A/D conversion/comparate completed	R	–
6	ADSSTP A/D conversion stop bit	0: No operation 1: Stop A/D conversion	0	W
7	ADSSTT A/D conversion start bit	0: No operation 1: Start A/D conversion	0	W

Note 1: Two bits—bit 0 (A/D hardware trigger select 1) and bit 2 (A/D hardware trigger select 0)—are used to select an A/D hardware trigger.

Note 2: During comparator mode, hardware triggers, if any selected, are ignored and operation is started by a software trigger.

A/D Single Mode Register 0 is used to control operation of the A/D Converter during single mode (including special mode, "Forcible single mode execution during scan mode").

**(1) ADSTRG (A/D Hardware Trigger Select) bits (Bits 0, 2)**

These bits select a hardware trigger when A/D conversion by the A/D Converter is to be started in hardware. Select one from the following hardware trigger sources:

A/D0 Converter: Input event bus 2  
Input event bus 3  
Output event bus 3  
TIN23 edge select output

The contents of these bits are ignored if a software trigger is selected by ADSSEL (A/D conversion start trigger select bit).

**(2) ADSSEL (A/D Conversion Start Trigger Select) bit (Bit 3)**

This bit selects whether to use a software or hardware trigger to start A/D conversion during single mode. If a software trigger is selected, A/D conversion is started by setting the ADSSTT (A/D conversion start) bit to "1." If a hardware trigger is selected, A/D conversion is started by the trigger source selected with the ADSTRG (hardware trigger select) bits.

**(3) ADSREQ (A/D Interrupt Request/DMA Transfer Request Select) bit (Bit 4)**

This bit selects whether to request an A/D conversion interrupt or a DMA transfer when single mode operation (A/D conversion or compare) is completed. If neither an interrupt nor a DMA transfer are used, choose to request an A/D conversion interrupt and use the A/D Conversion Interrupt Control Register of the Interrupt Controller (ICU) to mask the interrupt request, or choose to request a DMA transfer and use the DMA Channel Control Register to disable DMA transfers to be performed upon completion of A/D conversion.

**(4) ADSCMP (A/D Conversion/Compare Completed) bit (Bit 5)**

This is a read-only bit, whose value when exiting the reset state is "1." This bit is "0" when the A/D Converter is performing single mode operation (A/D conversion or compare) and is set to "1" when the operation finishes.

This bit is also set to "1" when A/D conversion or compare operation is forcibly terminated by setting the ADSSTP (A/D conversion stop) bit to "1" during A/D conversion or compare operation.

**(5) ADSSTP (A/D Conversion Stop) bit (Bit 6)**

Setting this bit to "1" while the A/D Converter is performing single mode operation (A/D conversion or compare) causes the operation being performed to stop. Manipulation of this bit is ignored while single mode operation is idle or scan mode operation is under way.

Operation stops immediately after writing to this bit. If the A/D Successive Approximation Register is read after being stopped, the content read from the register is the value in the middle of conversion (not transferred to the A/D Data Register).

If the A/D conversion start bit and A/D conversion stop bit are set to "1" at the same time, the A/D conversion stop bit has priority.

If this bit is set to "1" when performing single mode operation in special mode "Forcible single mode execution during scan mode," only single mode conversion stops and scan mode operation restarts.

**(6) ADSSTT (A/D Conversion Start) bit (Bit 7)**

If this bit is set to "1" when a software trigger has been selected with the ADSSEL (A/D conversion start trigger select) bit, the A/D Converter starts A/D conversion.

If the A/D conversion start bit and A/D conversion stop bit are set to "1" at the same time, the A/D conversion stop bit has priority.

If this bit is set to "1" again while performing single mode conversion, special operation mode "Conversion restart" is turned on, so that single mode conversion restarts.

If this bit is set to "1" again while performing A/D conversion in scan mode, special operation mode "Forcible single mode execution during scan mode" is turned on, so that the channel being converted in scan mode is canceled and single mode conversion is performed. When the single mode conversion finishes, scan mode A/D conversion restarts beginning with the canceled channel.

#### 11.2.2 A/D Single Mode Register 1

A/D0 Single Mode Register 1 (AD0SIM1)

<Address: H'0080 0081>

b8	9	10	11	12	13	14	b15
ADSM SL	ADSSPD	ADSSHSL	ADSSHSPD	ANSEL			
0	0	0	0	0	0	0	0

<Upon exiting reset: H'00>

b	Bit Name	Function	R	W
8	ADSM SL A/D conversion mode select bit	0: A/D0 conversion mode 1: Comparator mode	R	W
9	ADSSPD (Note 1) A/D conversion speed select bit	0: Normal speed 1: Double speed	R	W
10	ADSSHSL A/D conversion method select bit	0: Disable sample-and-hold 1: Enable sample-and-hold	R	W
11	ADSSHSPD (Note 2) A/D sample-and-hold conversion speed select bit	0: Normal sample-and-hold 1: Fast sample-and-hold	R	W
12–15	ANSEL A/D analog input pin select bit	0000 : Select ADiIN0 0001 : Select ADiIN1 0010 : Select ADiIN2 0011 : Select ADiIN3 0100 : Select ADiIN4 0101 : Select ADiIN5 0110 : Select ADiIN6 0111 : Select ADiIN7 1000 : Select ADiIN8 1001 : Select ADiIN9 1010 : Select ADiIN10 1011 : Select ADiIN11 1100 : Select ADiIN12 1101 : Select ADiIN13 1110 : Select ADiIN14 1111 : Select ADiIN15	R	W

Note 1: The A/D conversion speed is determined by a combination of ADSSPD, ADSSHSL and ADSSHSPD bits and the A/D Conversion Speed Control Register ADCVSD2 and ADCVSD bits.

Note 2: Setting of this bit is effective when the sample-and-hold function is enabled by ADSSHSL bit.

A/D Single Mode Register 1 is used to select operation mode, conversion speed and analog input pins when the A/D Converter is operating in single mode.

**(1) ADSMSL (A/D Conversion Mode Select) bit (Bit 8)**

This bit selects A/D conversion mode when the A/D Converter is operating in single mode. Setting this bit to "0" selects A/D conversion mode, and setting this bit to "1" selects comparator mode.

**(2) ADSSPD (A/D Conversion Speed Select) bit (Bit 9)**

This bit selects the A/D conversion speed when the A/D Converter is operating in single mode. Setting this bit to "0" selects normal speed, and setting this bit to "1" selects double speed.

**(3) ADSSHSL (A/D Conversion Method Select) bit (Bit 10)**

This bit enables or disables the sample-and-hold function when the A/D Converter is operating in single mode. Setting this bit to "0" disables the sample-and-hold function, and setting this bit to "1" enables the sample-and-hold function.

Setting of this bit has no effect if comparator mode is selected with the ADSMSL (A/D conversion mode select) bit.

**(4) ADSSHSPD (A/D Sample-and-Hold Speed Select) bit (Bit 11)**

When the A/D Converter's sample-and-hold function is enabled, this bit selects a conversion speed. When this bit is "0," the conversion speed is the same as normal A/D conversion speed. When this bit is "1", conversion is performed at a speed faster than normal A/D conversion speed.

Setting of this bit has no effect if the sample-and-hold function is disabled by setting the ADSSHSL (A/D conversion method select) bit to "0."

For details about the conversion time, see Section 11.3.4, "Calculating the A/D Conversion Time."

**(5) ANSEL (A/D Analog Input Pin Select) bits (Bits 12–15)**

These bits select the analog input pins when the A/D Converter is operating in single mode. A/D conversion or compare operation is performed on the channels selected with these bits. If these bits are accessed for read, the value written to them is read out.

### 11.2.3 A/D Single Mode Register 2

A/D0 Single Mode Register 2 (AD0SIM2)

&lt;Address: H'0080 0083&gt;

b8	9	10	11	12	13	14	b15
AD0SH2	AD0SH2ST			AD0SEL2			
0	0	0	0	0	0	0	0

&lt;Upon exiting reset: H'00&gt;

b	Bit Name	Function	R	W
8	ADSH2 A/D simultaneous sampling select bit (Note 1)	0: Simultaneous sampling invalid 1: Simultaneous sampling valid	R	W
9	ADSH2ST A/D simultaneous sampling status bit (Note 2)	0: 2nd simultaneous sampling conversion not in progress 1: 2nd simultaneous sampling conversion in progress	R	–
10, 11	No function assigned. Fix to "0."		R	0
12–15	ADSEL2 A/D simultaneous sampling analog input pin select bit (Note 3)	0000 : No channels selected     0011 : No channels selected 1100 : Select AD0IN12 1101 : Select ADi0N13 1110 : Select ADi0N14 1111 : Select ADi0N15	R	W

Note 1: The A/D conversion mode/sample-and-hold function must be effective with single mode register 1. When the comparator mode/sample-and-hold function is invalid, set the AD0SH2 to "0" (Simultaneous sampling invalid).

Note 2: The second conversion speed is the same as the first conversion speed.

Note 3: When simultaneous sampling valid is selected, select from B'1100 to B'1111. Furthermore, when simultaneous sampling invalid is selected, select from B'0000 to B'1011.

The A/D single mode register 2 is provided to select simultaneous sampling valid or invalid in the single mode of A/D converter and analog input pin sampled at the same time.

#### (1) ADSH2 (A/D Simultaneous Sampling Select) bit (Bit 8)

This bit selects whether simultaneous sampling is valid or invalid when the A/D converter is in single mode. By clearing this bit to "0," simultaneous sampling becomes invalid and by setting it to "1," simultaneous sampling becomes valid.

#### (2) ADSH2ST (A/D Simultaneous Sampling Status) bit (Bit 9)

This bit indicates that the number of times the A/D conversion is executed when simultaneous sampling is effective. The bit is set to "1" only when second conversion is in progress.

#### (3) ADSEL2 (A/D Simultaneous Sampling Analog Input Pin Select) bit (Bits 12–15)

These bits select a channel sampled at the same time when simultaneous sampling is effective.

## 11.2.4 A/D Scan Mode Register 0

A/D0 Scan Mode Register 0 (AD0SCM0)

&lt;Address: H'0080 0084&gt;

b0	1	2	3	4	5	6	b7
ADCTRG1	ADCMSL	ADCTRG0	ADCSEL	ADCREQ	ADCCMP	ADCSTP	ADCSTT
0	0	0	0	0	1	0	0

&lt;Upon exiting reset: H'04&gt;

b	Bit Name	Function	R	W
0	ADCTRG1 (Note 1) A/D hardware trigger select 1 bit	Bits 0 and 2 are used to select an A/D hardware trigger b0 b2 0 0 : Input event bus 2 0 1 : Input event bus 3 1 0 : Output event bus 3 1 1 : TIN23S signal	R	W
1	ADCMSL A/D scan mode select bit	0: Single-shot mode 1: Continuous mode	R	W
2	ADCTRG0 A/D hardware trigger select 0 bit	Bits 0 and 2 are used to select an A/D hardware trigger (See the column for bit 0.)	R	W
3	ADCSEL A/D conversion start trigger select bit	0: Software trigger 1: Hardware trigger	R	W
4	ADCREQ A/D Interrupt/DMA transfer request select bit	0: A/D conversion interrupt request 1: DMA transfer request	R	W
5	ADCCMP A/D conversion completed bit	0: A/D conversion in progress 1: A/D conversion completed	R	–
6	ADCSTP A/D conversion stop bit	0: No operation 1: Stop A/D conversion	0	W
7	ADCSTT A/D conversion start bit	0: No operation 1: Start A/D conversion	0	W

Note 1: Two bits—bit 0 (A/D hardware trigger select 1) and bit 2 (A/D hardware trigger select 0)—are used to select an A/D hardware trigger.

A/D Scan Mode Register 0 is used to control operation of the A/D Converter during scan mode.

**(1) ADCTRG (A/D Hardware Trigger Select) bits (Bits 0 and 2)**

These bits select a hardware trigger when A/D conversion by the A/D Converter is to be started in hardware. Select one from the following hardware trigger sources:

- A/D0 Converter: Input event bus 2
- Input event bus 3
- Output event bus 3
- TIN23 edge select output

The contents of these bits are ignored if a software trigger is selected by ADCSEL (A/D conversion start trigger select bit).



**(2) ADCMSL (A/D Scan Mode Select) bit (Bit 1)**

This bit selects scan mode of the A/D Converter between single-shot scan and continuous scan.

Setting this bit to "0" selects single-shot scan mode, where the channels selected with the ANSCAN (A/D scan loop select) bits of the A/D0 Scan Mode Register 1 (AD0SCM1) are sequentially A/D converted and when A/D conversion on all selected channels is completed, the conversion operation stops.

Setting this bit to "1" selects continuous scan mode, where after operation in single-shot scan mode finishes, A/D conversion is reexecuted beginning with the first channel and continued until stopped by setting the ADCSTP (A/D conversion stop) bit to "1."

**(3) ADCSEL (A/D Conversion Start Trigger Select) bit (Bit 3)**

This bit selects whether to use a software or hardware trigger to start A/D conversion during scan mode. If a software trigger is selected, A/D conversion is started by setting the ADCSTT (A/D conversion start) bit to "1." If a hardware trigger is selected, A/D conversion is started by the trigger source selected with the ADCTRG (hardware trigger select) bits.

**(4) ADCREQ (A/D Interrupt Request/DMA Transfer Request Select) bit (Bit 4)**

This bit selects whether to request an A/D conversion interrupt or a DMA transfer when one cycle of scan mode operation is completed. If neither an interrupt nor a DMA transfer are used, choose to request an A/D conversion interrupt and use the A/D Conversion Interrupt Control Register of the Interrupt Controller (ICU) to mask the interrupt request, or choose to request a DMA transfer and use the DMA Channel Control Register to disable DMA transfers to be performed upon completion of A/D conversion.

**(5) ADCCMP (A/D Conversion Completed) bit (Bit 5)**

This is a read-only bit, whose value when exiting the reset state is "1." This bit is "0" when the A/D Converter is performing scan mode A/D conversion and is set to "1" when single-shot scan mode finishes or continuous scan mode is stopped by setting the ADCSTP (A/D conversion stop) bit to "1."

**(6) ADCSTP (A/D Conversion Stop) bit (Bit 6)**

Setting this bit to "1" while the A/D Converter is performing scan mode A/D conversion causes the operation being performed to stop. This bit is effective only for scan mode operation, and does not affect single mode operation even when single and scan modes both are active during special operation mode.

Operation stops immediately after writing to this bit, and the A/D conversion being performed on any channel is aborted in the middle, without transferring the result to the A/D data register.

If the A/D conversion start bit and A/D conversion stop bit are set to "1" at the same time, the A/D conversion stop bit has priority.

**(7) ADCSTT (A/D Conversion Start) bit (Bit 7)**

This bit is used to start scan mode operation of the A/D Converter in software. Only when a software trigger has been selected with the ADCSEL (A/D conversion start trigger select) bit, setting this bit to "1" causes A/D conversion to start.

If the A/D conversion start bit and A/D conversion stop bit are set to "1" at the same time, the A/D conversion stop bit has priority.

If this bit is set to "1" again while performing scan mode conversion, special operation mode "Conversion restart" is turned on, so that scan mode operation is restarted using the contents set by A/D Scan Mode Registers 0 and 1.

If this bit is set to "1" again while performing A/D conversion in single mode, special operation mode "Scan mode start after single mode execution" is turned on, so that scan mode operation starts subsequently after single mode has finished.

## 11.2.5 A/D Scan Mode Register 1

A/D0 Scan Mode Register 1 (AD0SCM1)

&lt;Address: H'0080 0085&gt;

b8	9	10	11	12	13	14	b15
0	ADCSPD 0	ADCSHSL 0	ADCSHSPD 0	0	0	0	0

&lt;Upon exiting reset: H'00&gt;

b	Bit Name	Function	R	W
8	No function assigned. Fix to "0."		0	0
9	ADCSPD (Note 1) A/D conversion speed select bit	0: Normal speed 1: Double speed	R	W
10	ADCSHSL A/D conversion method select bit	0: Disable sample-and-hold 1: Enable sample-and-hold	R	W
11	ADCSHSPD (Note 2) A/D sample-and-hold conversion speed select bit	0: Normal sample-and-hold 1: Fast sample-and-hold	R	W
12–15	ANSCAN A/D scan loop select bit	<For write> 'B0000–1111 (channels 0–15) <For read during conversion> (i = 0) 0000: Converting ADiIN0 0001: Converting ADiIN1 0010: Converting ADiIN2 0011: Converting ADiIN3 0100: Converting ADiIN4 0101: Converting ADiIN5 0110: Converting ADiIN6 0111: Converting ADiIN7 1000: Converting ADiIN8 1001: Converting ADiIN9 1010: Converting ADiIN10 1011: Converting ADiIN11 1100: Converting ADiIN12 1101: Converting ADiIN13 1110: Converting ADiIN14 1111: Converting ADiIN15	R	W

Note 1: The A/D conversion speed is determined by a combination of ADCSPD, ADCSHSL and ADCSHSPD bits and the A/D Conversion Speed Control Register AD0CVSD2 and AD0CVSD bits.

Note 2: Setting of this bit is effective when the sample-and-hold function is enabled by ADCSHSL bit.

A/D Scan Mode Register 1 is used to select operation mode, conversion speed and scan loop when the A/D Converter is operating in scan mode. The channels selected with the scan loop select bit are scanned sequentially beginning with channel 0 (n-channel scan).

**(1) ADCSPD (A/D Conversion Speed Select) bit (Bit 9)**

This bit selects an A/D conversion speed when the A/D Converter is operating in scan mode. Setting this bit to "0" selects normal speed, and setting this bit to "1" selects double speed.

**(2) ADCSHSL (A/D Conversion Method Select) bit (Bit 10)**

This bit enables or disables the sample-and-hold function when the A/D Converter is operating in scan mode. Setting this bit to "0" disables the sample-and-hold function, and setting this bit to "1" enables the sample-and-hold function.

**(3) ADCSHSPD (A/D Sample-and-Hold Conversion Speed Select) bit (Bit 11)**

When the A/D Converter's sample-and-hold function is enabled, this bit selects a conversion speed. When this bit is "0," the conversion speed is the same as normal A/D conversion speed. When this bit is "1," conversion is performed at a speed faster than normal A/D conversion speed.

Setting of this bit has no effect if the sample-and-hold function is disabled by setting the ADCSHSL (A/D conversion method select) bit to "0."

For details about the conversion time, see Section 11.3.4, "Calculating the A/D Conversion Time."

**(4) ANSCAN (A/D Scan Loop Select) bits (Bits 12–15)**

The ANSCAN (A/D scan loop select) bits set the channels to be scanned during scan mode of the A/D Converter.

The ANSCAN (A/D scan loop select) bits when accessed for read during scan operation serve as a status register indicating the channel being scanned.

The value read from these bits during single mode is always B'0000.

When it is read out by One shot mode after scan operation is completed, the channel value changed last time is read out.

If A/D conversion is stopped by setting A/D Scan Mode Register 0 ADCSTP (A/D conversion stop) bit to "1" while executing scan mode, the value read from these bits indicates the channel whose A/D conversion has been canceled.

Also, if read during single mode conversion of special operation mode "Forcible single mode execution during scan mode," the value of these bits indicates the channel whose A/D conversion has been canceled in the middle of scan.

### 11.2.6 A/D Conversion Speed Control Register

A/D0 Conversion Speed Control Register (AD0CVSCR)

<Address: H'0080 0087>

b8	9	10	11	12	13	14	b15
0	0	0	0	0	0	ADCVSD2 0	ADCVSD 0

<Upon exiting reset: H'00>

b	Bit Name	Function	R	W
8–13	No function assigned. Fix to "0."		0	0
14	ADCVSD2 A/D conversion speed control bit 2	0: 2BCLK mode 1: Setting prohibited	R	W
15	ADCVSD (Note 1) A/D conversion speed control bit	0: Slow mode 1: Fast mode	R	W

Note 1: The A/D conversion speed is determined by a combination of ADCVSD and ADCVSD2 bits and A/D0 Single Mode Register 1's ADSSPD bit during single mode, or a combination of ADCVSD and ADCVSD2 bits and A/D Scan Mode Register 1's ADCSPD bit during scan mode.

The A/D Conversion Speed Control Register controls the A/D conversion speed during single and scan modes of the A/D Converter. The A/D conversion speed is determined in combination with the conversion speed select bits (Double/Normal) in A/D Single Mode Register 1 and A/D Scan Mode Register 1.

### 11.2.7 A/D Disconnection Detection Assist Function Control Register

A/D0 Disconnection Detection Assist Function Control Register (AD0DDACR)

<Address: H'0080 0086>

b0	1	2	3	4	5	6	b7
0	0	0	0	0	0	0	ADDDAEN 0

<Upon exiting reset: H'00>

b	Bit Name	Function	R	W
0-6	No function assigned. Fix to "0."		0	0
7	ADDDAEN (Note 1) A/D disconnection detection assist function enable bit	0: Disable A/D disconnection detection assist function 1: Enable A/D disconnection detection assist function	R	W

Note 1: For the A/D disconnection detection assist function to be enabled, the conversion start state (discharge or precharge) must be set using the A/D disconnection detection assist method select register after setting the ADDDAEN bit to "1."

The A/D Disconnection Detection Assist Function Control Register is used to enable or disable the content of the A/D Disconnection Detection Assist Method Select Register.

Note: • If any analog input wiring is disconnected, the conversion result varies depending on the circuits fitted external to the chip. This function must be fully evaluated in the actual application system before it can be used.

### 11.2.8 A/D Disconnection Detection Assist Method Select Register

A/D0 Disconnection Detection Assist Method Select Register (AD0DDASEL)

<Address: H'0080 008A>

b0	1	2	3	4	5	6	7	8	9	10	11	12	13	14	b15
ADDDASEL0 ?	ADDDASEL1 ?	ADDDASEL2 ?	ADDDASEL3 ?	ADDDASEL4 ?	ADDDASEL5 ?	ADDDASEL6 ?	ADDDASEL7 ?	ADDDASEL8 ?	ADDDASEL9 ?	ADDDASEL10 ?	ADDDASEL11 ?	ADDDASEL12 ?	ADDDASEL13 ?	ADDDASEL14 ?	ADDDASEL15 ?

<Upon exiting reset: Undefined>

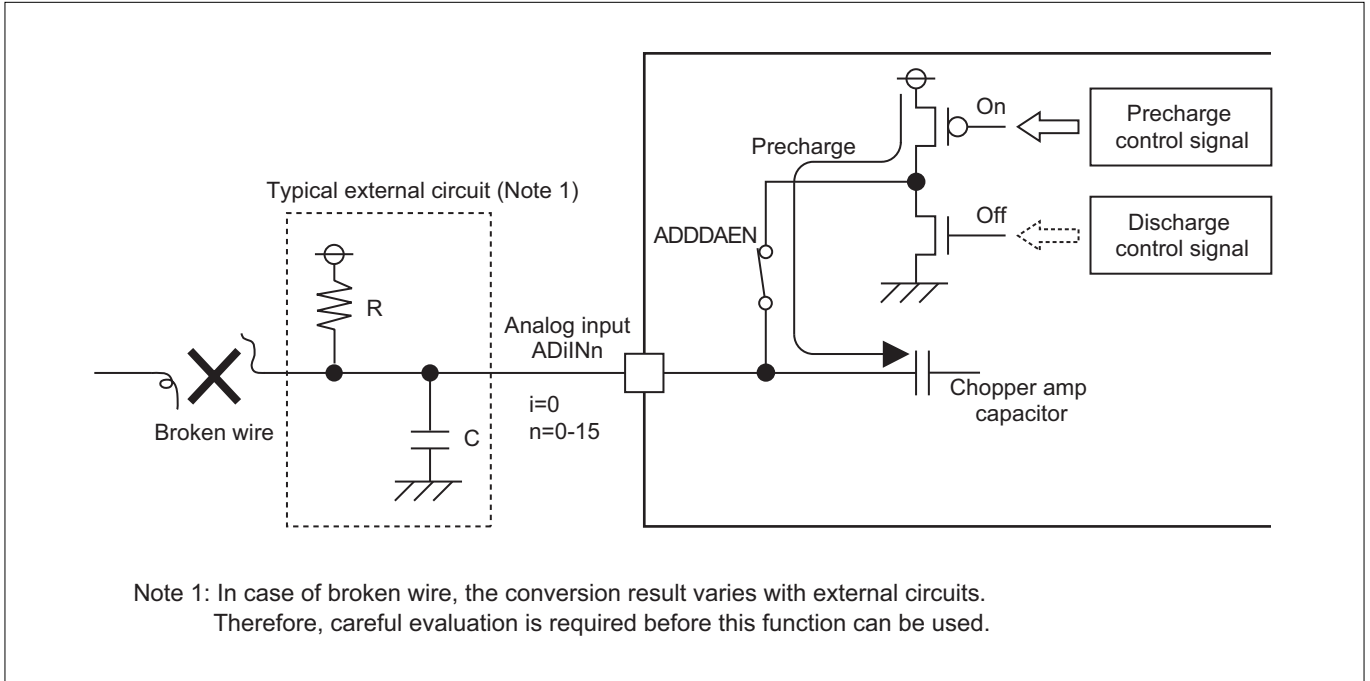
b	Bit Name	Function	R	W
0	ADDDASEL0 Channel 0 disconnection detection assist method select bit	0: Discharge before conversion 1: Precharge before conversion	R	W
1	ADDDASEL1 Channel 1 disconnection detection assist method select bit			
2	ADDDASEL2 Channel 2 disconnection detection assist method select bit			
3	ADDDASEL3 Channel 3 disconnection detection assist method select bit			
4	ADDDASEL4 Channel 4 disconnection detection assist method select bit			
5	ADDDASEL5 Channel 5 disconnection detection assist method select bit			
6	ADDDASEL6 Channel 6 disconnection detection assist method select bit			
7	ADDDASEL7 Channel 7 disconnection detection assist method select bit			
8	ADDDASEL8 Channel 8 disconnection detection assist method select bit			
9	ADDDASEL9 Channel 9 disconnection detection assist method select bit			
10	ADDDASEL10 Channel 10 disconnection detection assist method select bit			
11	ADDDASEL11 Channel 11 disconnection detection assist method select bit			
12	ADDDASEL12 Channel 12 disconnection detection assist method select bit			
13	ADDDASEL13 Channel 13 disconnection detection assist method select bit			
14	ADDDASEL14 Channel 14 disconnection detection assist method select bit			
15	ADDDASEL15 Channel 15 disconnection detection assist method select bit			

Notes: • This register must always be accessed in halfwords.

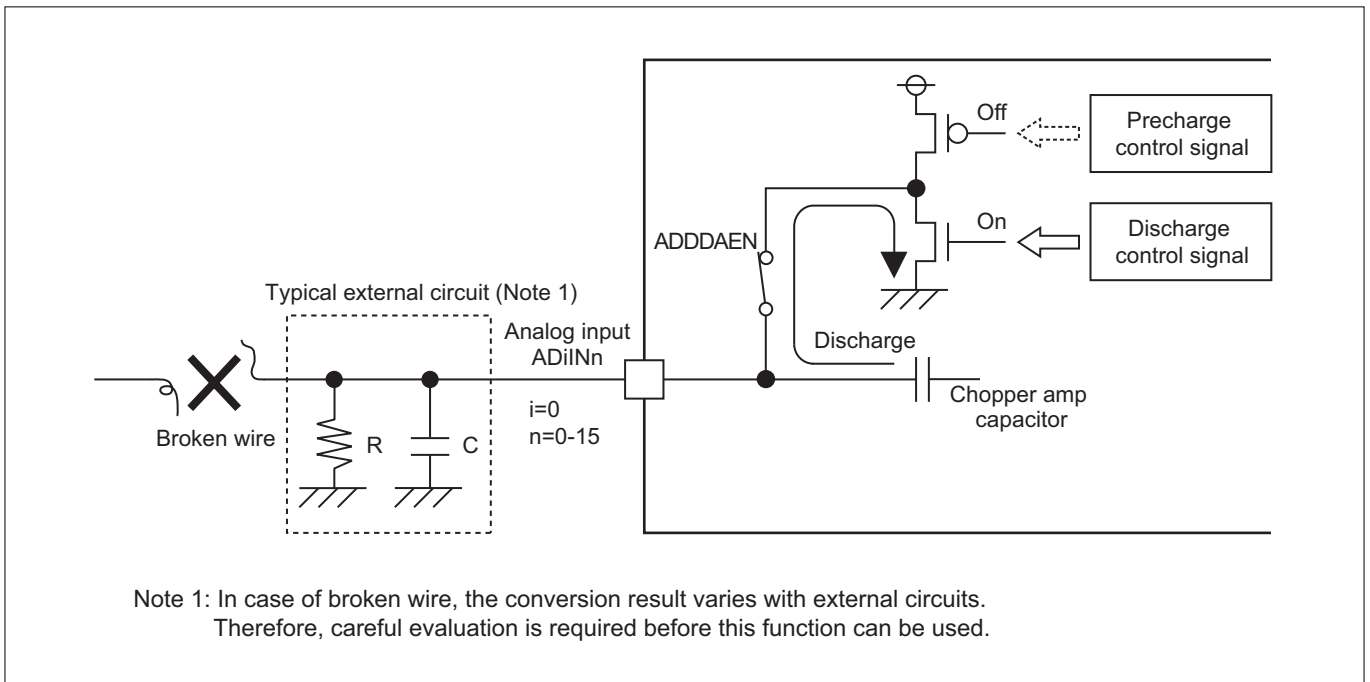
- For these bits to be enabled, the ADDDAEN bit (A/D Disconnection Detection Assist Function Control Register bit 7) must be set to "1" before setting these bits.

In order to prevent the A/D conversion result from being affected by the analog input voltage leakage from any preceding channel, the A/D Disconnection Detection Assist Method Select Register is used to control the conversion start state by selecting whether to discharge or precharge the chopper amp capacitor before starting regular conversion operation.

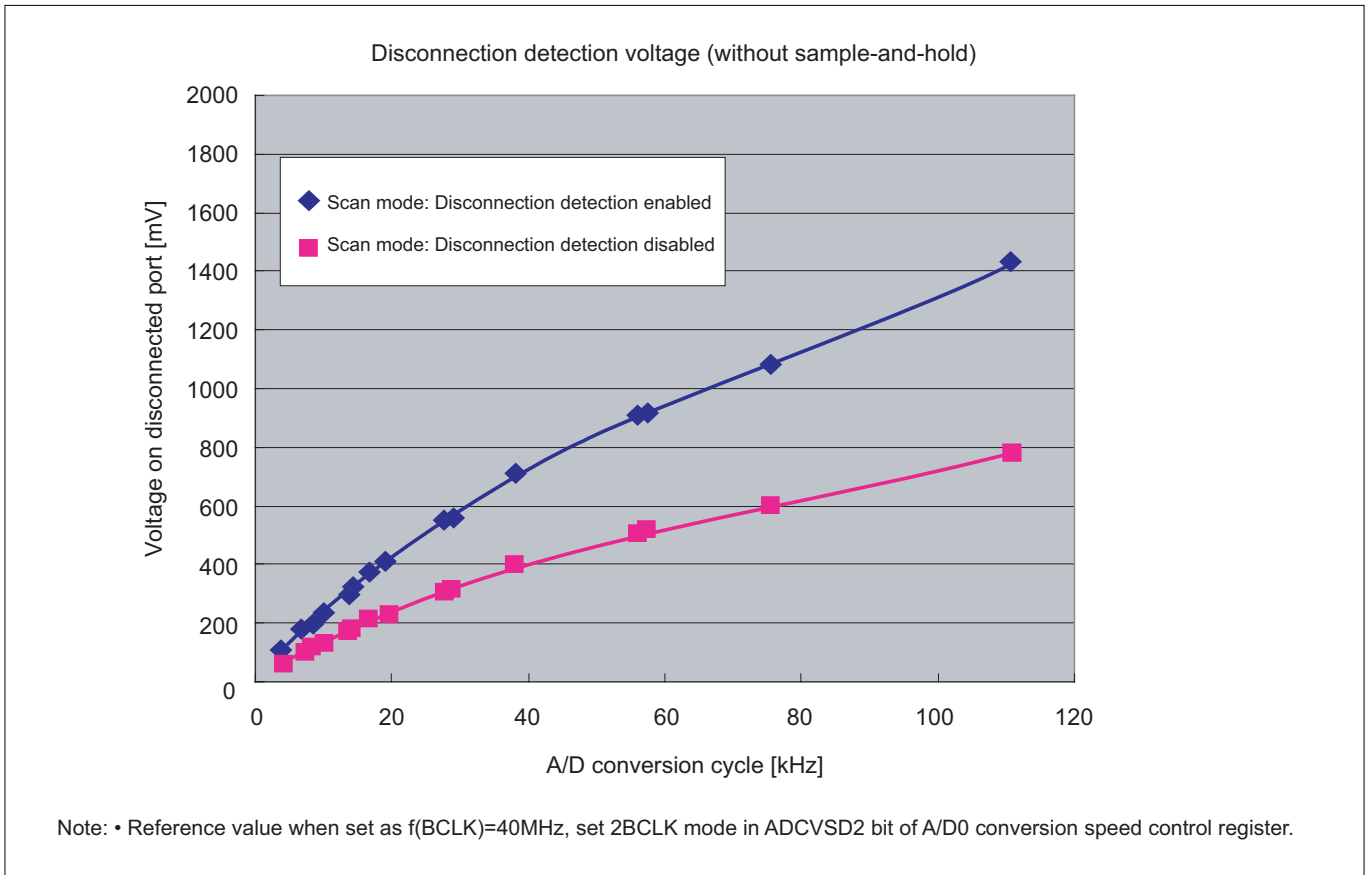
Figure 11.2.1 shows an example of A/D disconnection detection assist method in which the conversion start state is set to the AVCC0 side (i.e., precharge before conversion is selected). Figure 11.2.2 shows an example of A/D disconnection detection assist method in which the conversion start state is set to the AVSS0 side (i.e., discharge before conversion is selected).



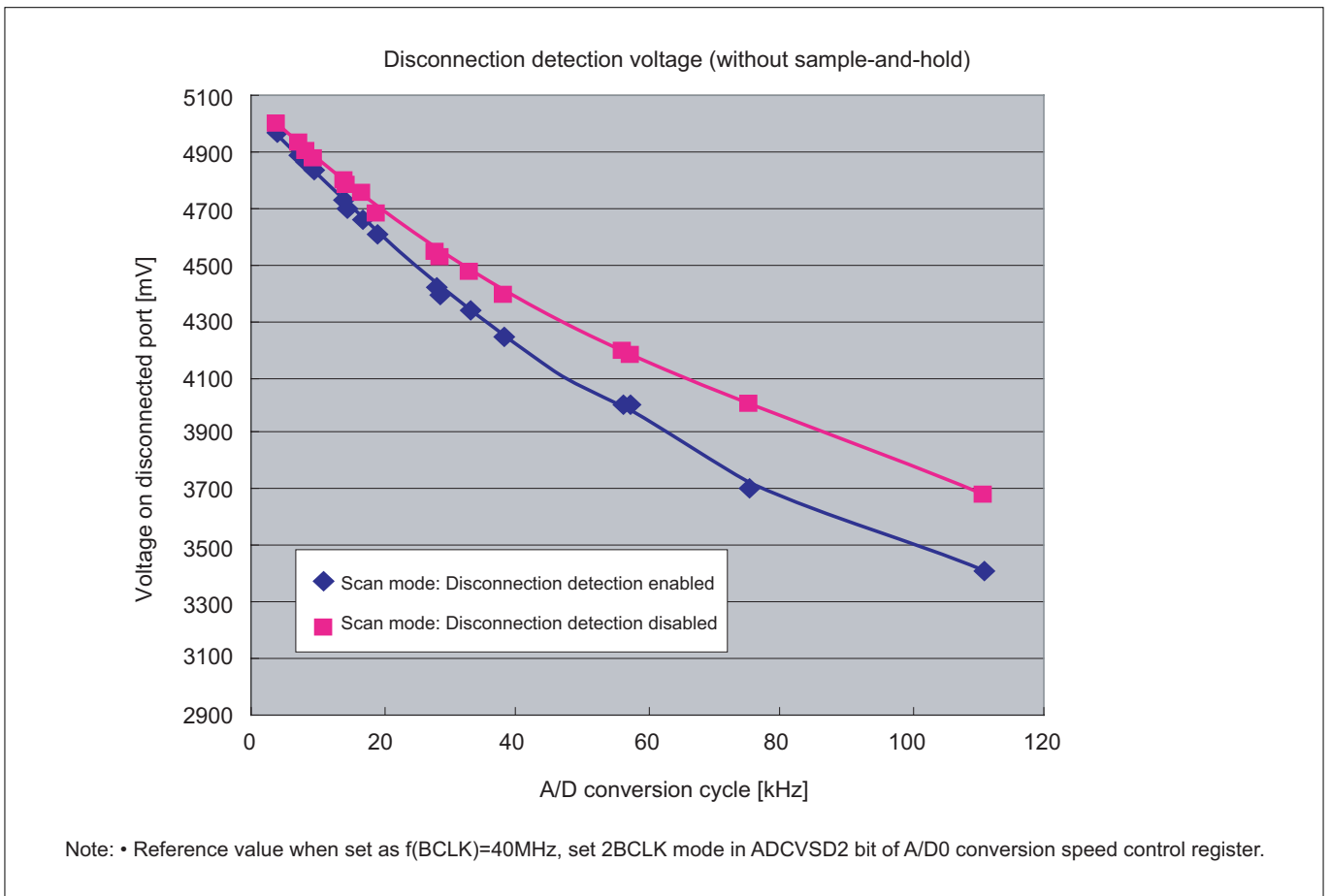
**Figure 11.2.1 Example of A/D Disconnection Detection on AVCC0 Side (Precharge Before Conversion Selected)**



**Figure 11.2.2 Example of A/D Disconnection Detection on AVSS0 Side (Discharge Before Conversion Selected)**



**Figure 11.2.3 A/D Disconnection Detection Assist Data (when Discharge Before Conversion Selected)**



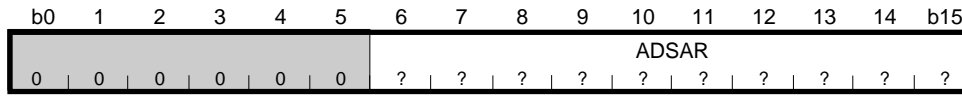
**Figure 11.2.4 A/D Disconnection Detection Assist Data (when Precharge Before Conversion Selected)**



### 11.2.9 A/D Successive Approximation Register

A/D0 Successive Approximation Register(AD0SAR)

<Address: H'0080 0088>



<Upon exiting reset: Undefined>

b	Bit Name	Function	R	W
0–5	No function assigned. Fix to "0."		0	0
6–15	ADSAR	• A/D successive approximation value (A/D conversion mode)	R	W
	A/D successive approximation value/comparison value	• Comparison value (comparator mode)		

Note: • This register must always be accessed in halfwords.

The A/D Successive Approximation Register (ADSAR) is used to read the conversion result of the A/D Converter when operating in A/D conversion mode or write a comparison value when operating in comparator mode.

In A/D conversion mode, the successive approximation method is used to perform A/D conversion. With this method, the reference voltage VREF0 and analog input voltages are sequentially compared bitwise beginning with the high-order bit, and the comparison result is set in the A/D Successive Approximation Register (ADSAR) bits 6–15. When the A/D conversion has finished, the value of this register is transferred to the 10-bit A/D Data Register (ADDTn) corresponding to each converted channel. When this register is accessed for read in the middle of A/D conversion, the value read from the register indicates the intermediate result of conversion.

In comparator mode, this register is used to write a comparison value (the voltage with which to “compare”). Simultaneously with a write to this register, the A/D Converter starts comparing the voltage on the analog input pin selected with A/D Single Mode Register 1 and the value written in this register. After compare operation, the result is stored in the A/D Compare Data Register (ADCMP).

Use the calculation formula shown below to find the comparison value to be written to the A/D Successive Approximation Register (ADSAR) during comparator mode.

$$\text{Comparison value} = \text{H}'3\text{FF} \times \frac{\text{Compare compare voltage [V]}}{\text{VREF0 input voltage [V]}}$$

#### 11.2.10 A/D Compare Data Register

A/D0 Compare Data Register (AD0CMP)

<Address: H'0080 008C>

b0	1	2	3	4	5	6	7	8	9	10	11	12	13	14	b15
AD CMP0 ?	AD CMP1 ?	AD CMP2 ?	AD CMP3 ?	AD CMP4 ?	AD CMP5 ?	AD CMP6 ?	AD CMP7 ?	AD CMP8 ?	AD CMP9 ?	AD CMP10 ?	AD CMP11 ?	AD CMP12 ?	AD CMP13 ?	AD CMP14 ?	AD CMP15 ?

<Upon exiting reset: Undefined>

b	Bit Name	Function	R	W
0–15	ADCMP0–ADCMP15 (Note 1) A/D compare result flag	0: Analog input voltage > comparison voltage 1: Analog input voltage < comparison voltage	R	–

Note 1: During comparator mode, the bits in this register correspond one for one to channels 0–15.

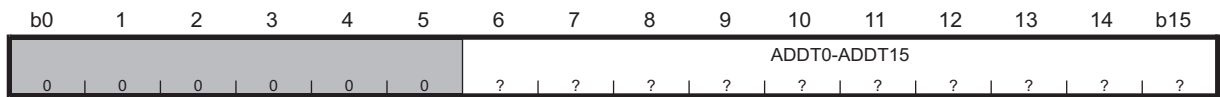
Note: • This register must always be accessed in halfwords.

When comparator mode is selected using the A/D Single Mode Register 1 ADSMSL (A/D conversion mode select) bit, the selected analog input voltage is compared with the value written to the A/D Successive Approximation Register and the result is stored in the corresponding bit of this compare data register.

The bit or flag in this register is "0" when analog input voltage > comparison voltage, or "1" when analog input voltage < comparison voltage.

#### 11.2.11 10-bit A/D Data Registers

10-bit A/D0 Data Register 0(AD0DT0)	<Address: H'0080 0090>
10-bit A/D0 Data Register 1(AD0DT1)	<Address: H'0080 0092>
10-bit A/D0 Data Register 2(AD0DT2)	<Address: H'0080 0094>
10-bit A/D0 Data Register 3(AD0DT3)	<Address: H'0080 0096>
10-bit A/D0 Data Register 4(AD0DT4)	<Address: H'0080 0098>
10-bit A/D0 Data Register 5(AD0DT5)	<Address: H'0080 009A>
10-bit A/D0 Data Register 6(AD0DT6)	<Address: H'0080 009C>
10-bit A/D0 Data Register 7(AD0DT7)	<Address: H'0080 009E>
10-bit A/D0 Data Register 8(AD0DT8)	<Address: H'0080 00A0>
10-bit A/D0 Data Register 9(AD0DT9)	<Address: H'0080 00A2>
10-bit A/D0 Data Register 10(AD0DT10)	<Address: H'0080 00A4>
10-bit A/D0 Data Register 11(AD0DT11)	<Address: H'0080 00A6>
10-bit A/D0 Data Register 12(AD0DT12)	<Address: H'0080 00A8>
10-bit A/D0 Data Register 13(AD0DT13)	<Address: H'0080 00AA>
10-bit A/D0 Data Register 14(AD0DT14)	<Address: H'0080 00AC>
10-bit A/D0 Data Register 15(AD0DT15)	<Address: H'0080 00AE>



<Upon exiting reset: Undefined>

b	Bit Name	Function	R	W
0-5	No function assigned.		0	0
6-15	ADDT0-ADDT15 10-bit A/D data	10-bit A/D conversion result	R	-

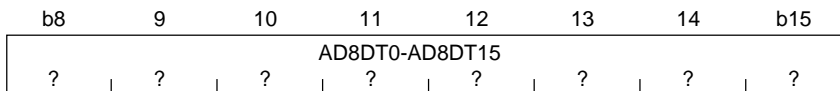
Note: • These registers must always be accessed in halfwords.

During single mode, the 10-bit A/D Data Registers are used to store the result of A/D conversion performed on each corresponding channel.

During single-shot or continuous scan mode, the content of the A/D Successive Approximation Register is transferred to the 10-bit A/D Data Register for the corresponding channel when A/D conversion on each channel has finished. Each 10-bit A/D Data Register retains the last conversion result until they receive the next conversion result transferred, allowing the content to be read out at any time.

#### 11.2.12 8-bit A/D Data Registers

8-bit A/D0 Data Register 0(AD08DT0)	<Address: H'0080 00D1>
8-bit A/D0 Data Register 1(AD08DT1)	<Address: H'0080 00D3>
8-bit A/D0 Data Register 2(AD08DT2)	<Address: H'0080 00D5>
8-bit A/D0 Data Register 3(AD08DT3)	<Address: H'0080 00D7>
8-bit A/D0 Data Register 4(AD08DT4)	<Address: H'0080 00D9>
8-bit A/D0 Data Register 5(AD08DT5)	<Address: H'0080 00DB>
8-bit A/D0 Data Register 6(AD08DT6)	<Address: H'0080 00DD>
8-bit A/D0 Data Register 7(AD08DT7)	<Address: H'0080 00DF>
8-bit A/D0 Data Register 8(AD08DT8)	<Address: H'0080 00E1>
8-bit A/D0 Data Register 9(AD08DT9)	<Address: H'0080 00E3>
8-bit A/D0 Data Register 10(AD08DT10)	<Address: H'0080 00E5>
8-bit A/D0 Data Register 11(AD08DT11)	<Address: H'0080 00E7>
8-bit A/D0 Data Register 12(AD08DT12)	<Address: H'0080 00E9>
8-bit A/D0 Data Register 13(AD08DT13)	<Address: H'0080 00EB>
8-bit A/D0 Data Register 14(AD08DT14)	<Address: H'0080 00ED>
8-bit A/D0 Data Register 15(AD08DT15)	<Address: H'0080 00EF>



<Upon exiting reset: Undefined>

b	Bit Name	Function	R	W
8-15	AD8DT0-AD8DT15 8-bit A/D data	8-bit A/D conversion result	R	-

The A/D data register is used to store the 8-bit conversion data for the A/D converter.

During single mode, the 8-bit A/D Data Registers store the result of A/D conversion performed on each corresponding channel.

During single-shot or continuous scan mode, the content of the A/D Successive Approximation Register is transferred to the 8-bit A/D Data Register for the corresponding channel when A/D conversion on each channel has finished. Each 8-bit A/D Data Register retains the last conversion result until they receive the next conversion result transferred, allowing the content to be read out at any time.

## 11.3 Functional Description of A/D Converter

### 11.3.1 How to Find Analog Input Voltages

The A/D Converter performs A/D conversion using a 10-bit successive approximation method. The equation shown below is used to calculate the actual analog input voltage from the digital value obtained by executing A/D conversion.

$$\text{Analog input voltage [V]} = \frac{\text{A/D conversion result} \times \text{VREF input voltage [V]}}{1,024}$$

The A/D Converter is a 10-bit converter, providing a resolution of 1,024 discrete voltage levels. Because the reference voltage for the A/D Converter is the voltage applied to the VREF0 pin, make sure that an exact and stable constant-voltage power supply is connected to VREF0. Also make sure the analog circuit power supply and ground (AVCC0, AVSS0) are separated from those of the digital circuit, with sufficient noise prevention measures incorporated.

For details about the conversion accuracy, see Section 11.3.5, "Accuracy of A/D Conversion."

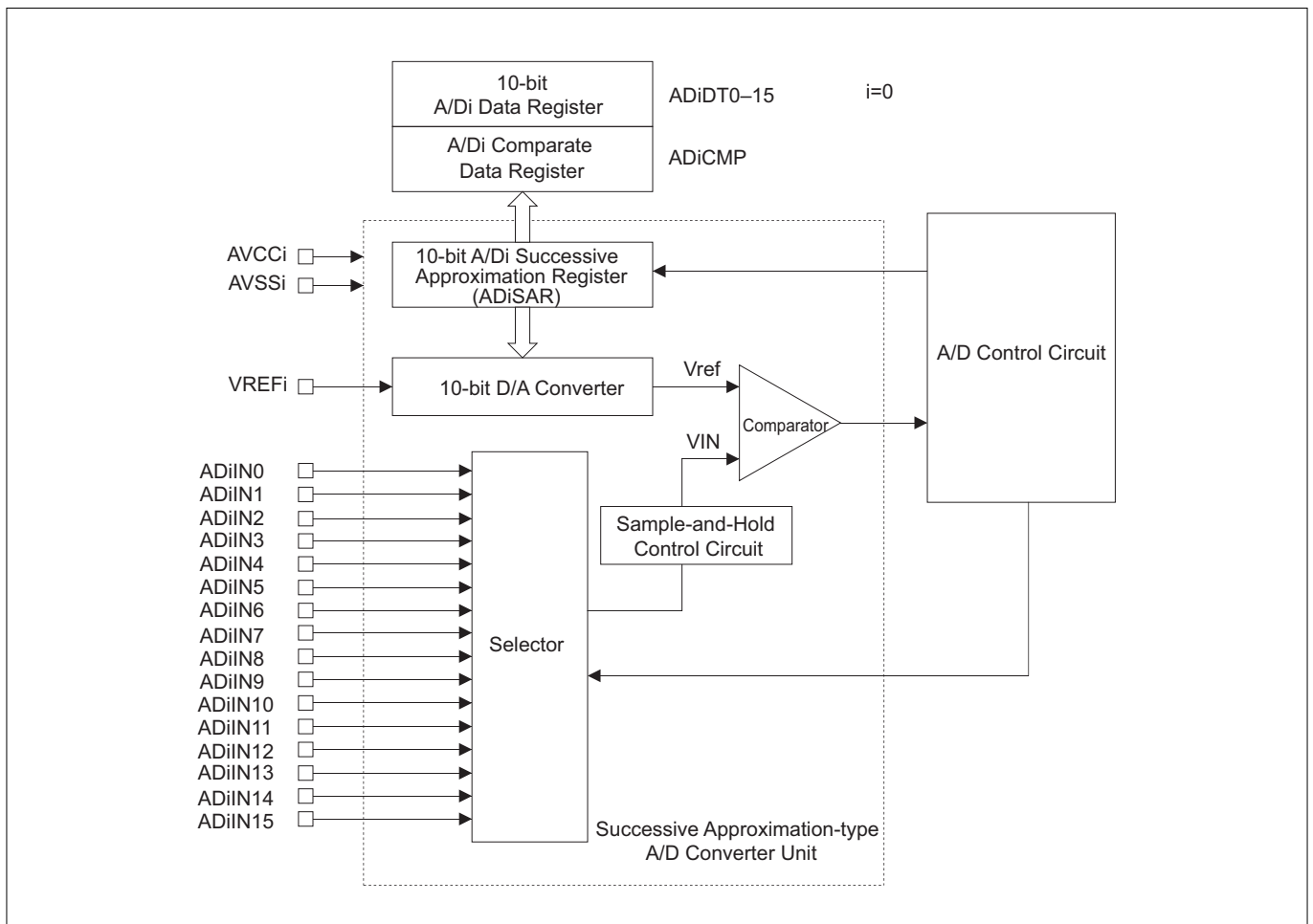
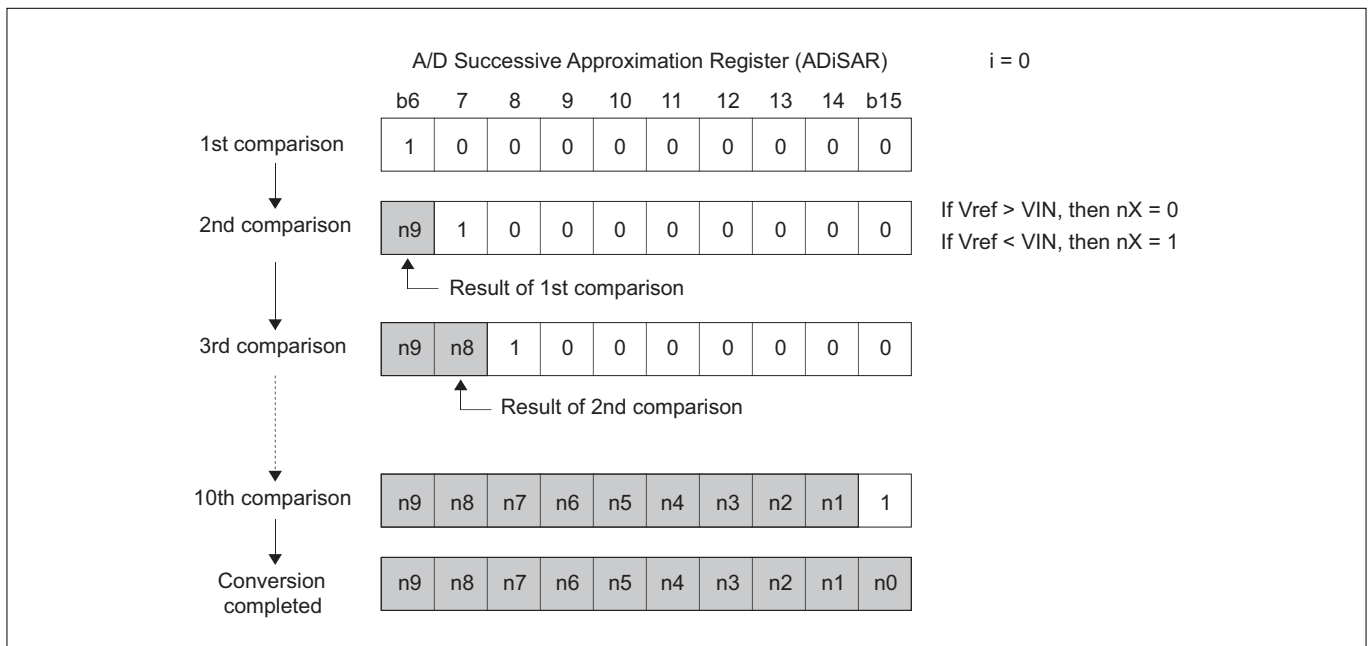


Figure 11.3.1 Outline Block Diagram of the Successive Approximation-type A/D Converter Unit

### 11.3.2 A/D Conversion by Successive Approximation Method

The A/D Converter use an A/D conversion start trigger (software or hardware) as they start A/D conversion. Once A/D conversion begins, the following operation is automatically performed.

1. During single mode, A/D Single Mode Register 0's A/D conversion/comparate completion bit is cleared to "0." During scan mode, A/D Scan Mode Register 0's A/D conversion completion bit is cleared to "0."
2. The content of the A/D Successive Approximation Register is cleared to H'0000.
3. The A/D Successive Approximation Register's most significant bit (bit 6) is set to "1."
4. The comparison voltage, Vref (Note 1), is fed from the D/A Converter into the comparator.
5. The comparison voltage, Vref, and the analog input voltage, VIN, are compared, and the comparison result will be stored in bit 6.
  - If  $V_{ref} < V_{IN}$ , then bit 6 = "1"
  - If  $V_{ref} > V_{IN}$ , then bit 6 = "0"
6. Operations in 3 through 5 above are executed for all other bits from bit 7 to bit 15.
7. The value stored in the A/D Successive Approximation Register by the time comparison for bit 15 has finished is held in it as the A/D conversion result.



**Figure 11.3.2 Changes of the A/D Successive Approximation Register during A/D Convert Operation**

Note 1: The comparison voltage, Vref (the voltage fed from the D/A Converter into the comparator), is determined according to changes of the A/D Successive Approximation Register content. Shown below are the equations used to calculate the comparison voltage, Vref.

- If the A/D Successive Approximation Register content = 0  
 $V_{ref} [V] = 0$
- If the A/D Successive Approximation Register content = 1 to 1,023  
 $V_{ref} [V] = (\text{reference voltage } V_{REF0} / 1,024) \times (\text{A/D Successive Approximation Register content} - 0.5)$

The conversion result is stored in the 10-bit A/D Data Register (AD0DTn) corresponding to each converted channel. There is also an 8-bit A/D Data Register (AD08DTn) for each channel, from which the 8 high-order bits of the 10-bit A/D conversion result can be read out.

The following shows the procedure for A/D conversion by a successive approximation method in each operation mode.

### (1) Single mode

The convert operation stops when comparison for the A/D Successive Approximation Register bit 15 is completed. The content (A/D conversion result) of the A/D Successive Approximation Register is transferred to the 10-bit A/D Data Registers 0–15 for the converted channel.

### (2) Single-shot scan mode

When comparison for the A/D Successive Approximation Register bit 15 on a specified channel is completed, the content of the A/D Successive Approximation Register is transferred to the corresponding 10-bit A/D Data Registers 0–15, and the convert operations in said steps 2 to 7 are reexecuted for the next channel to be converted.

In single-shot scan mode, the convert operation stops when A/D conversion in one specified scan loop is completed.

### (3) Continuous scan mode

When comparison for the A/D Successive Approximation Register bit 15 on a specified channel is completed, the content of the A/D Successive Approximation Register is transferred to the corresponding 10-bit A/D Data Registers 0–15, and the convert operations in said steps 2 to 7 are reexecuted for the next channel to be converted.

In continuous scan mode, the convert operation is executed continuously until scan operation is forcibly terminated by setting the A/D conversion stop bit (Scan Mode Register 0 bit 6) to "1."

## 11.3.3 Comparator Operation

When comparator mode (single mode only) is selected, the A/D Converter functions as a comparator which compares analog input voltages with the comparison voltage that is set by software.

When a comparison value is written to the successive approximation register, the A/D Converter starts "comparing" the analog input voltage selected by the Single Mode Register 1 analog input select bit with the value written into the successive approximation register. Once compare begins, the following operation is automatically executed.

1. The A/D conversion/compare completion bit in the A/D Single Mode Register 0 is cleared to "0."
2. The comparison voltage,  $V_{ref}$  (Note 1), is fed from the D/A Converter into the comparator.
3. The comparison voltage,  $V_{ref}$ , and the analog input voltage,  $V_{IN}$ , are compared, and the comparison result will be stored in the compare result flag for the corresponding channel.
  - If  $V_{ref} < V_{IN}$ , then the compare result flag = 0
  - If  $V_{ref} > V_{IN}$ , then the compare result flag = 1
4. The compare operation is stopped after storing the comparison result.

The comparison result is stored in the A/D Compare Data Register (AD0CMP)'s corresponding bit.

Note 1: The comparison voltage,  $V_{ref}$  (the voltage fed from the D/A Converter into the comparator), is determined according to changes of the A/D Successive Approximation Register content. Shown below are the equations used to calculate the comparison voltage,  $V_{ref}$ .

- If the A/D Successive Approximation Register content = 0
 
$$V_{ref} [V] = 0$$
- If the A/D Successive Approximation Register content = 1 to 1,023
 
$$V_{ref} [V] = (\text{reference voltage } V_{REF0} / 1,024) \times (\text{A/D0 Successive Approximation Register content} - 0.5)$$

### 11.3.4 Calculating the A/D Conversion Time

The A/D conversion time is expressed by the sum of dummy cycle time and actual execution cycle time. The following shows each time factor necessary to calculate the conversion time.

#### 1. Start dummy time

A time from when the CPU executed the A/D conversion start instruction to when the A/D Converter starts A/D conversion

#### 2. A/D conversion execution cycle time

If sample-and-hold is enabled, the sampling time is included in this execution cycle time.

#### 3. Compare execution cycle time

#### 4. End dummy time

A time from when the A/D Converter has finished A/D conversion to when the CPU can stably read out the conversion result from the A/D data register.

#### 5. Scan to scan dummy time

A time during single-shot or continuous scan mode from when the A/D Converter has finished A/D conversion on a channel to when it starts A/D conversion on the next channel.

The equation to calculate the A/D conversion time is as follows:

$$\begin{aligned} \text{A/D conversion time} &= \text{Start dummy time} + \text{Execution cycle time} \\ &+ \text{Scan to scan dummy time} + \text{Execution cycle time} \\ &+ \text{Scan to scan dummy time} + \text{Execution cycle time} \\ &+ \text{Scan to scan dummy time} \dots + \text{Execution cycle time} \\ &+ \text{End dummy time} \end{aligned}$$

Note: • Enclosed in ( ) are the conversion time required for the second and subsequent channels to be converted in scan mode.

#### (1) Calculating the conversion time during A/D conversion mode

The following schematically shows the method for calculating the conversion time during A/D conversion mode.

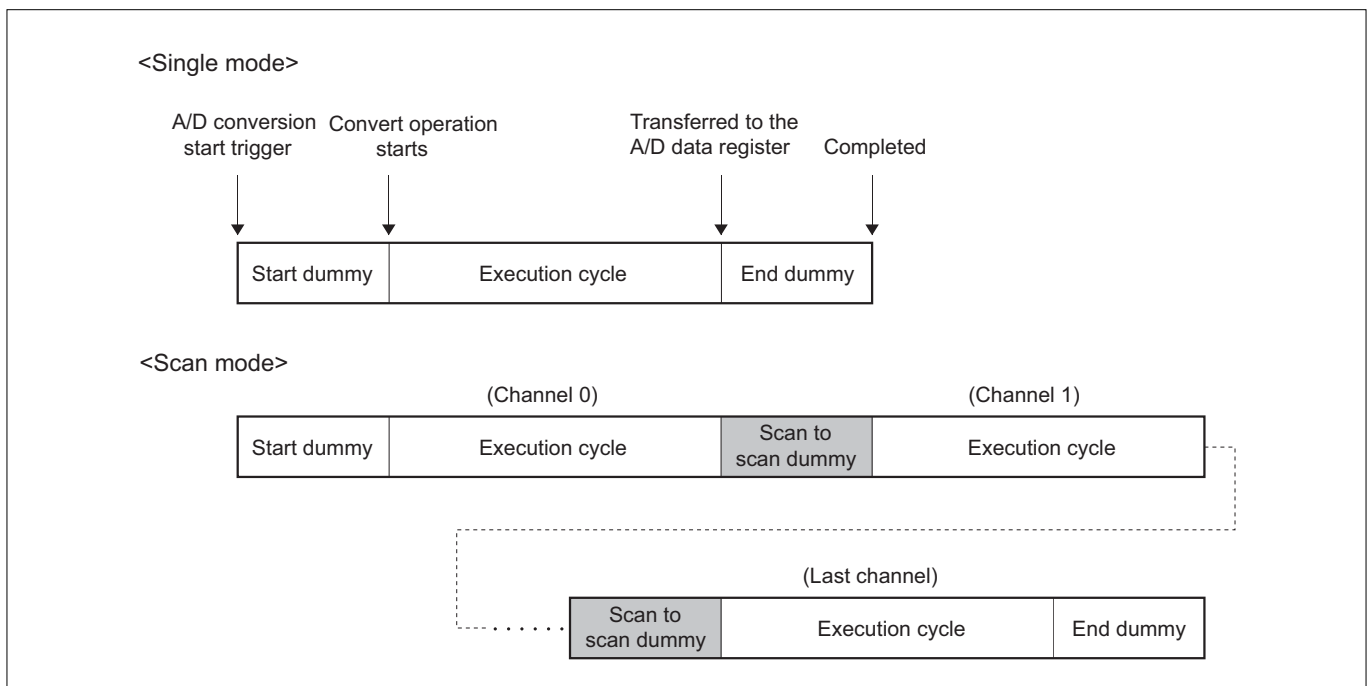


Figure 11.3.3 Conceptual Diagram of A/D Conversion Time



#### (2) Calculating the conversion time when sample-and-hold is enabled

The following schematically shows the method for calculating the conversion time when the sample-and-hold function is enabled.

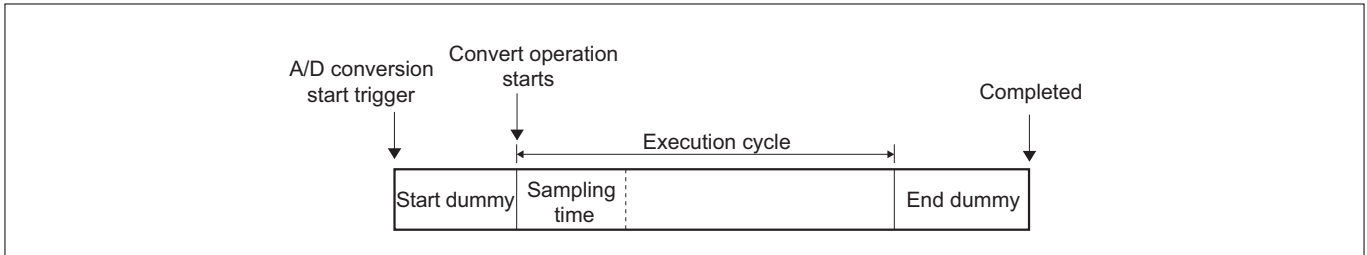


Figure 11.3.4 Conceptual Diagram of A/D Conversion Time when Sample-and-Hold is Enabled

**Table 11.3.1 Conversion Clock Periods in A/D Conversion Mode when Sample-and-Hold is Disabled or Normal Sample-and-Hold is Enabled (Shortest Period)** Unit: BCLK

Conversion speed			Start dummy (Note 1)	Execution cycle	End dummy	Scan to scan dummy (Note 2)
2BCLK mode	Slow mode	Normal speed	8	588	2	8
		Double speed	8	336	2	8
	Fast mode	Normal speed	8	252	2	8
		Double speed	8	168	2	8

Note 1: The same applies to both software and hardware triggers.

Note 2: Only during scan mode operation, execution time per channel is added.

**Table 11.3.2 Conversion Clock Periods in A/D Conversion Mode when Fast Sample-and-Hold is Enabled (Shortest Period)** Unit: BCLK

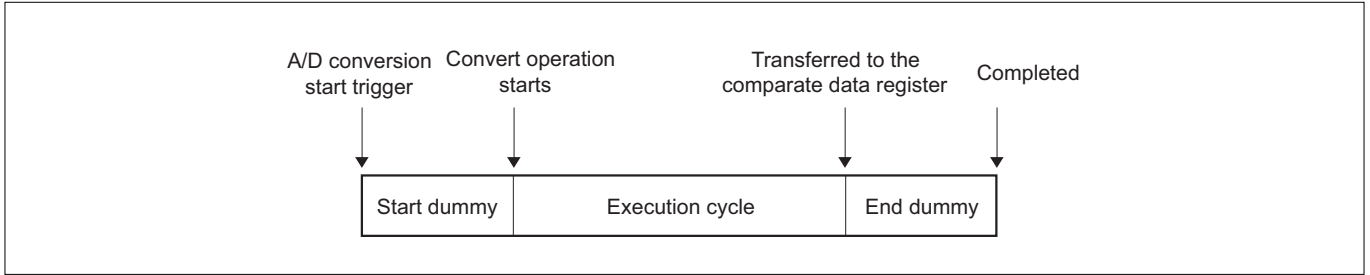
Conversion speed			Start dummy (Note 1)	Execution cycle	End dummy	Scan to scan dummy (Note 2)
2BCLK mode	Slow mode	Normal speed	8	372	2	8
		Double speed	8	192	2	8
	Fast mode	Normal speed	8	180	2	8
		Double speed	8	96	2	8

Note 1: The same applies to both software and hardware triggers.

Note 2: Only during scan mode operation, execution time per channel is added.

#### (3) Calculating the conversion time during comparator mode

The following schematically shows the method for calculating the conversion time during comparator mode.



**Figure 11.3.5 Conceptual Diagram of A/D Conversion Time during Comparator Mode**

**Table 11.3.3 Conversion Clock Periods in Compare Mode (Shortest Period)**

**Unit: BCLK**

Conversion speed			Start dummy	Execution cycle	End dummy
2BCLK mode	Slow mode	Normal speed	8	84	2
		Double speed	8	48	2
	Fast mode	Normal speed	8	36	2
		Double speed	8	24	2

#### (4) Calculating the conversion time during simultaneous sampling conversion

The following schematically shows the method for calculating the conversion time during the simultaneous sampling conversion.

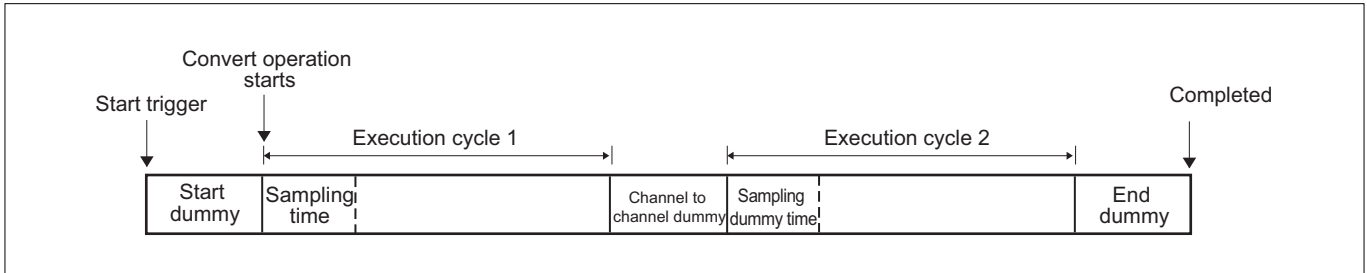


Figure 11.3.6 Conceptual Diagram of A/D Conversion Time during Simultaneous Sampling Conversion

Table 11.3.4 Conversion Clock Periods for Simultaneous Sampling when Normal Sample-and-Hold is Enabled (Shortest Period) Unit: BCLK

Conversion speed			Start dummy (Note 1)	Execution cycle 1	Channel to channel dummy	Execution cycle 2	End dummy
2BCLK mode	Slow mode	Normal speed	8	588	8	588	2
		Double speed	8	336	8	336	2
	Fast mode	Normal speed	8	252	8	252	2
		Double speed	8	168	8	168	2

Note 1: The same applies to both software and hardware triggers.

Table 11.3.5 Conversion Clock Periods for Simultaneous Sampling when Fast Sample-and-Hold is Enabled (Shortest Period) Unit: BCLK

Conversion speed			Start dummy (Note 1)	Execution cycle 1	Channel to channel dummy	Execution cycle 2	End dummy
2BCLK mode	Slow mode	Normal speed	8	372	8	372	2
		Double speed	8	192	8	192	2
	Fast mode	Normal speed	8	180	8	180	2
		Double speed	8	96	8	96	2

Note 1: The same applies to both software and hardware triggers.

**(5) Total A/D conversion time**

A total A/D conversion time in various modes are shown in the table below.

**Table 11.3.6 A/D Conversion Time (Total Time)****Unit: BCLK**

Conversion start method	Conversion speed		Conversion mode (Note 1)	Conversion time	When fast sample-and-hold enabled	
Software and hardware triggers (Note 2)	2BCLK mode	Slow mode	Single mode	598	382	
			Single-shot scan, n-channel scan/continuous mode	$(596 \times n)+2$	$(380 \times n)+2$	
			Comparator mode	94	94	
			Simultaneous sampling	1194	762	
		Double speed	Single mode	346	202	
			Single-shot scan, n-channel scan/continuous mode	$(344 \times n)+2$	$(200 \times n)+2$	
			Comparator mode	58	58	
			Simultaneous sampling	690	402	
		Fast mode	Normal speed	Single mode	262	190
				Single-shot scan, n-channel scan/continuous mode	$(260 \times n)+2$	$(188 \times n)+2$
				Comparator mode	46	46
				Simultaneous sampling	522	378
	Double speed		Single mode	178	106	
			Single-shot scan, n-channel scan/continuous mode	$(176 \times n)+2$	$(104 \times n)+2$	
			Comparator mode	34	34	
			Simultaneous sampling	354	210	

Note 1: For single mode and comparator mode, this indicates an A/D conversion or compare time per channel. For single-shot and continuous scan modes, this indicates an A/D conversion time per scan loop, and for simultaneous sampling, this indicates total time for the first and second conversion.

Note 2: This indicates a time from when a register write cycle has finished to when an A/D conversion completion interrupt request is generated, or a time from when an event bus or other MJT event has occurred to when an A/D conversion completion interrupt request is generated.

Note: • During 2BCLK mode, 1-2BCLK cycle(s) will be additionally generated at each start/end dummy cycle to synchronize with the clock.

### 11.3.5 Accuracy of A/D Conversion

The accuracy of the A/D Converter is indicated by an absolute accuracy. The absolute accuracy refers to a difference expressed by LSB between the output code obtained by A/D converting the analog input voltages and the output code expected for an A/D converter with ideal characteristics. The analog input voltages used during accuracy measurement are the midpoint values of the voltage width in which an A/D converter with ideal characteristics produces the same output code. If  $V_{REF0} = 5.12\text{ V}$ , for example, the width of 1 LSB for a 10-bit A/D converter is 5 mV, so that 0 mV, 5 mV, 10 mV, 15 mV, 20 mV, 25 mV and so on are selected as midpoints of the analog input voltage.

If an A/D converter is said to have the absolute accuracy of  $\pm 2\text{ LSB}$ , it means that if the input voltage is 25 mV, for example, the output code expected for an A/D converter with ideal characteristics is H'005, and the actual A/D conversion result is in the range of H'003 to H'007. Note that the absolute accuracy includes zero and full-scale errors.

When actually using the A/D Converter, the analog input voltages are in the range of  $AVSS0$  to  $V_{REF0}$ . Note, however, that low  $V_{REF0}$  voltages result in a poor resolution. Note also that output codes for the analog input voltages from  $V_{REF0}$  to  $AVCC0$  are always H'3FF.

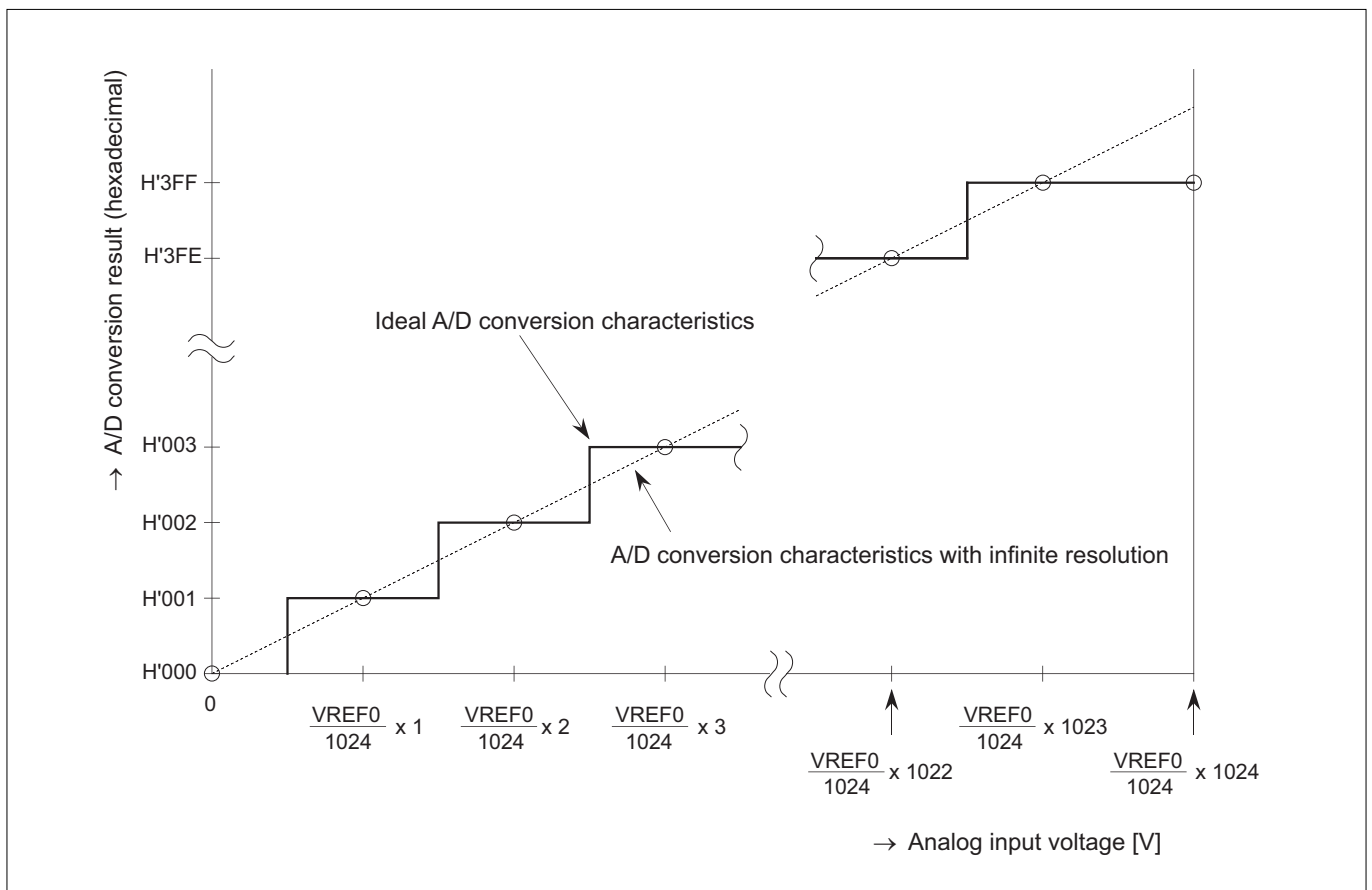


Figure 11.3.7 Ideal A/D Conversion Characteristics Relative to the 10-bit A/D Converter's Analog Input Voltages

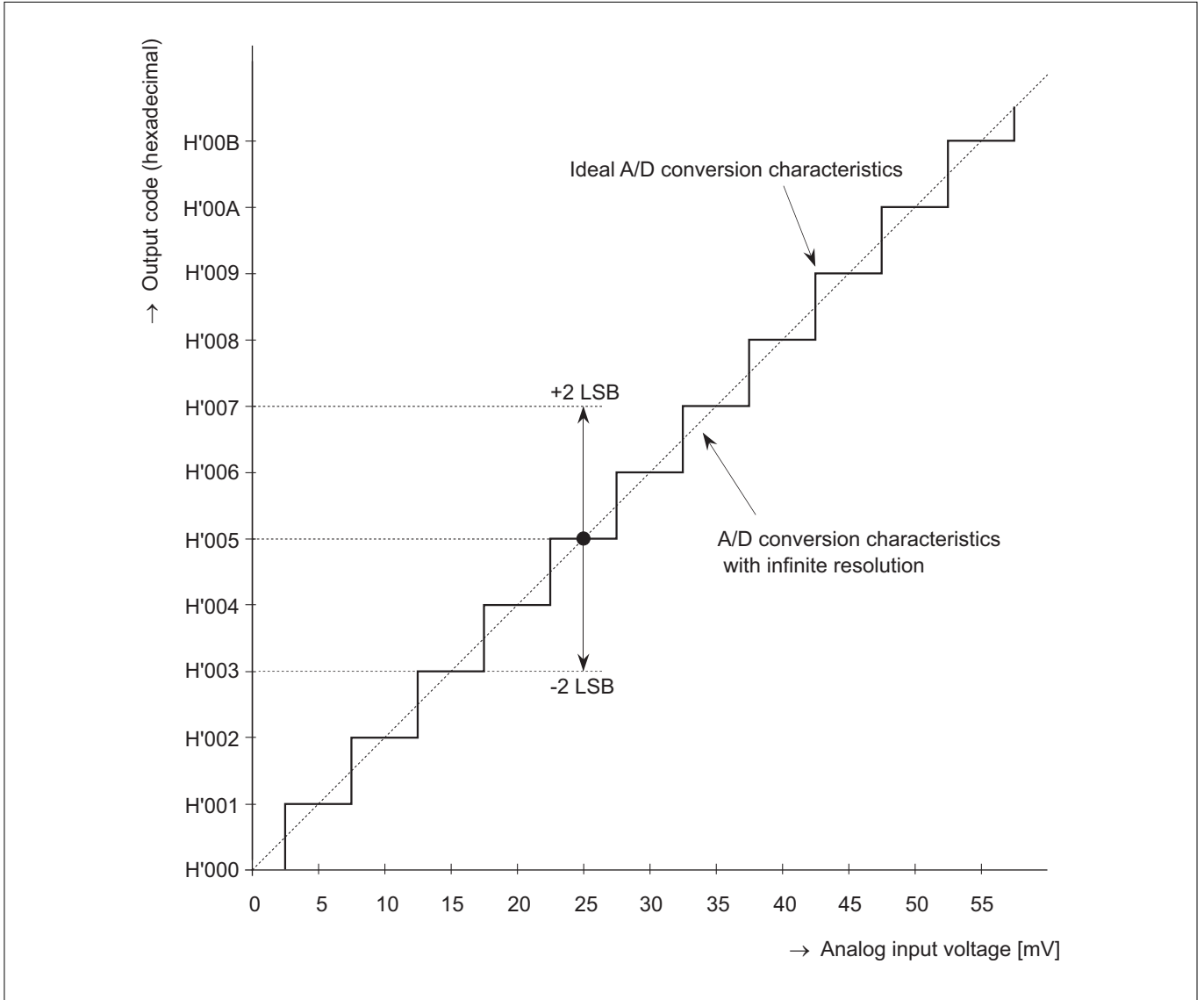


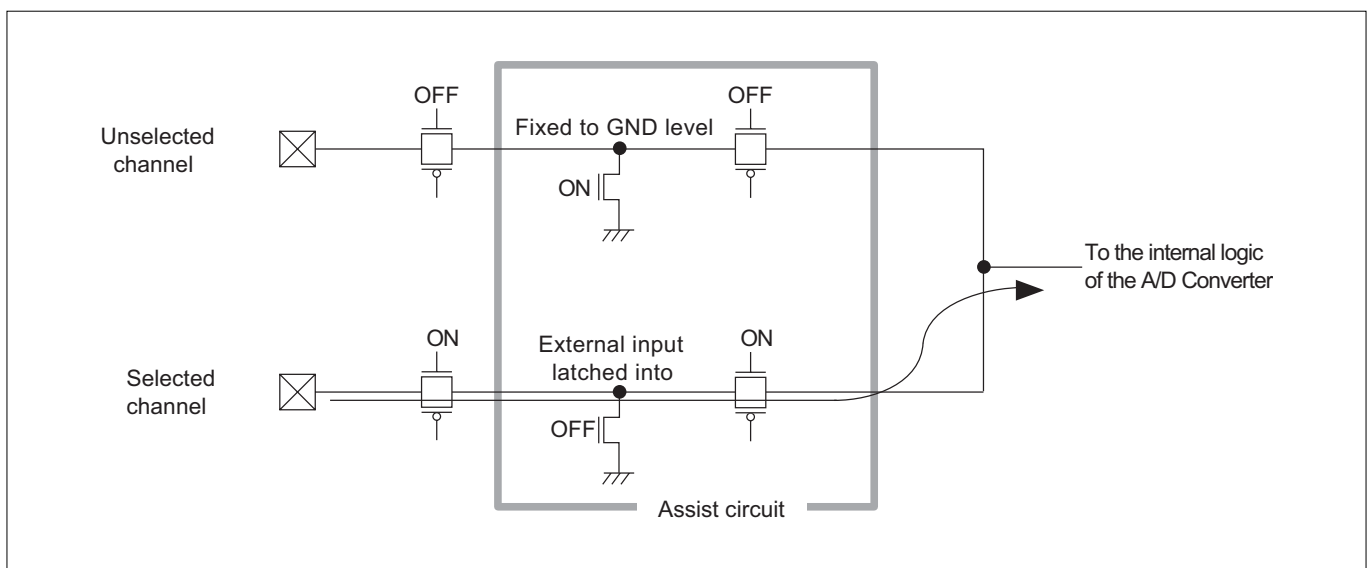
Figure 11.3.8 Absolute Accuracy of A/D Converter

#### 11.4 Inflow Current Bypass Circuit

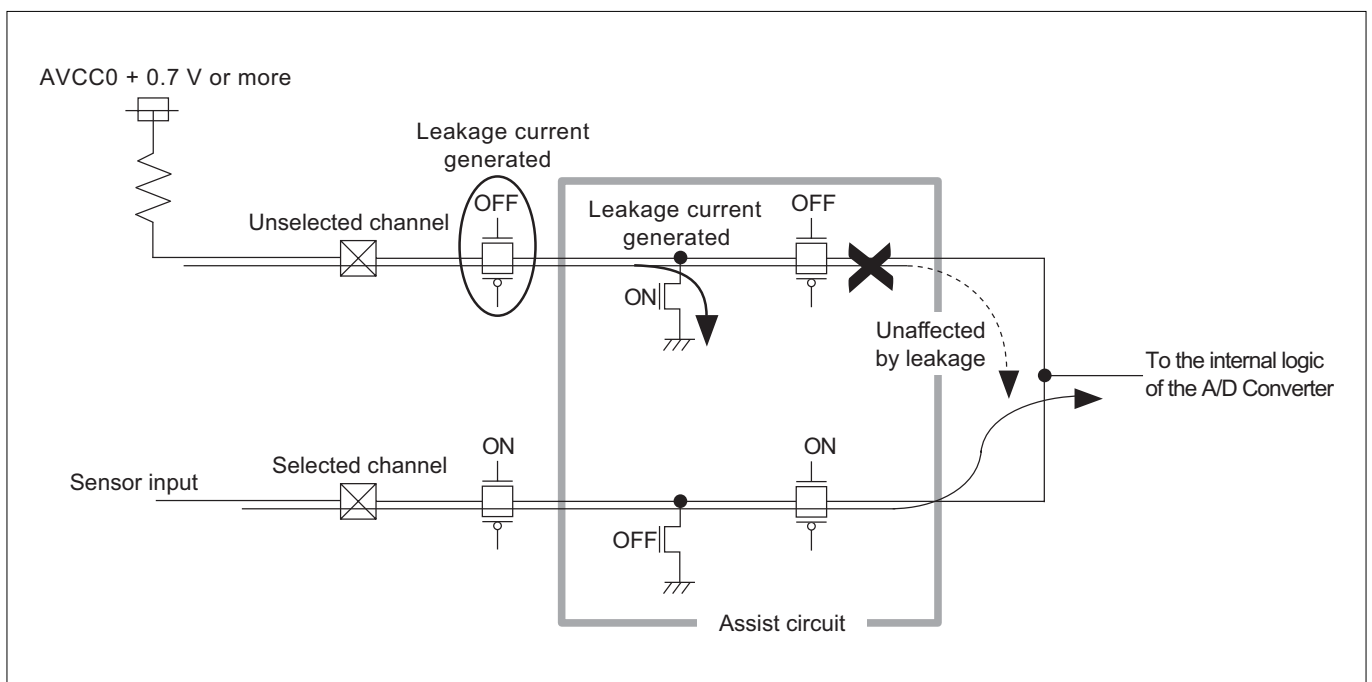
If when the A/D Converter is A/D converting a selected analog input an overvoltage exceeding the converter's absolute maximum rating is applied to any unselected analog input, the selector for the unselected analog input is inadvertently turned on by that overvoltage. This causes current to leak to the selected analog input, and the accuracy of the A/D conversion result is thereby deteriorated.

The Inflow Current Bypass Circuit fixes the internal signals of unselected analog inputs to the GND level, so that when an overvoltage is applied, this circuit lets the current flow into the GND and prevents it from leaking to the selected analog input. That way, the accuracy of the A/D conversion result is prevented from being deteriorated by overvoltages.

This circuit is always active while the A/D Converter is operating, and does not need to be controlled in software.



**Figure 11.4.1 Configuration of the Inflow Current Bypass Circuit**



**Figure 11.4.2 Example of an Inflow Current Bypass Circuit where AVCC0 + 0.7 V or More is Applied**

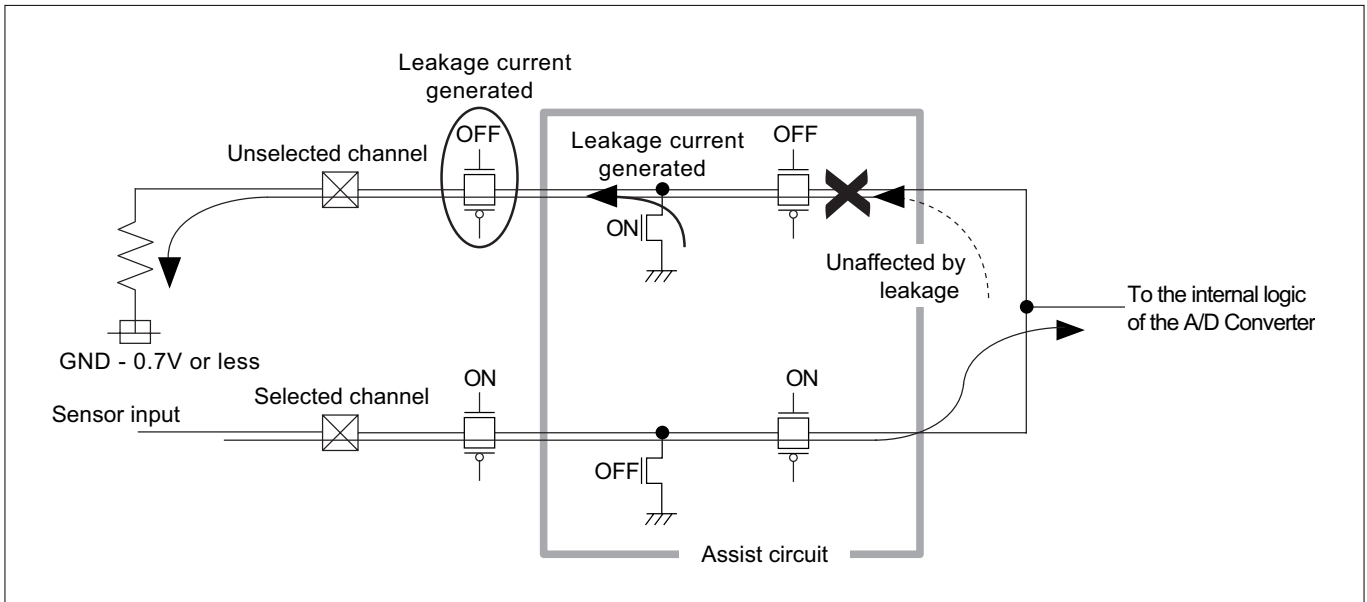


Figure 11.4.3 Example of an Inflow Current Bypass Circuit where GND – 0.7 V or Less is Applied

Table 11.4.1 Accuracy Errors (Reference Values) when Current is Injected into AD0IN0

		Accuracy error on overcurrent injected ports (Unit: LSB)															
Analog input pin		AD0IN0	AD0IN1	AD0IN2	AD0IN3	AD0IN4	AD0IN5	AD0IN6	AD0IN7	AD0IN8	AD0IN9	AD0IN10	AD0IN11	AD0IN12	AD0IN13	AD0IN14	AD0IN15
Injection current	2mA	X	4	2	2	2	2	2	2	2	2	2	2	2	2	2	2
	1mA	X	2	2	2	2	2	2	2	2	2	2	2	2	2	2	2
	0mA	X	2	2	2	2	2	2	2	2	2	2	2	2	2	2	2
	-1mA	X	1	2	2	2	2	2	2	2	2	2	2	2	2	2	2
	-2mA	X	0	2	2	2	2	2	2	2	2	2	2	2	2	2	2

Note: • Since the influence of the accuracy on a contiguity channel becomes large, do not inject an over-current into the channel selected in the A/D0 simultaneous sampling analog input selection bit (ADSEL2) of the A/D single mode register 2 (ADSIM2). (No channel is selected if "0000"to"1011" is set up in 2 bit of ADSEL(s).)



## 11.5 Notes on the A/D Converter

### • Forcible termination during scan operation

If A/D conversion is forcibly terminated by setting the A/D conversion stop bit (ADCSTP) to "1" during scan mode operation and the A/D data register for the channel that was in the middle of conversion is accessed for read, the read value shows the last conversion result that had been transferred to the data register before the conversion was forcibly terminated.

### • Modification of the A/D converter related registers

If the content of any register—A/D Conversion Interrupt Control Register, Single or Scan Mode Registers or A/D Successive Approximation Register, except the A/D conversion stop bit—is modified in the middle of A/D conversion, the conversion result cannot be guaranteed. Therefore, do not modify the contents of these registers while A/D conversion is in progress, or be sure to restart A/D conversion if register contents have been modified.

### • Handling of analog input signals

When using the A/D Converter with its sample-and-hold function disabled, make sure the analog input level is fixed during A/D conversion.

### • A/D conversion completed bit read timing

To read the A/D conversion completed bit (the Single Mode Register 0 ADSCMP bit or the Scan Mode Register 0 ADCCMP bit), as well as the A/D simultaneous sampling status bit (the A/D0 Single Mode Register 2 ADSH2ST bit) immediately after A/D conversion has started or has been terminated by the A/D conversion stop bit, be sure to adjust the timing 6 BCLK periods by performing a dummy read of their registers before read.

### • Regarding the analog input pins

Figure 11.5.1 shows the internal equivalent circuit of the A/D Converter's analog input part. To obtain accurate A/D conversion results, make sure the internal capacitor C2 of the A/D conversion circuit is charged up within a predetermined time (sampling time). To meet this sampling time requirement, it is recommended that a stabilizing capacitor C1 be connected external to the chip.

The method for determining the necessary value of this external stabilizing capacitor with respect to the output impedance of an analog output device is described below. Also, an explanation is made of the case where the output impedance of an analog output device is low and the external stabilizing capacitor C1 is unnecessary.

### • Rated value of the absolute accuracy

The rated value of the absolute accuracy is the actual performance value of the microcomputer alone, with influences of the power supply wiring and noise on the board not taken into account. When designing the application system, use caution for the board layout by, for example, separating the analog circuit power supply and ground (AVCC, AVSS and VREF) from those of the digital circuit and incorporating measures to prevent the analog input pins from being affected by noise, etc. from other digital signals.

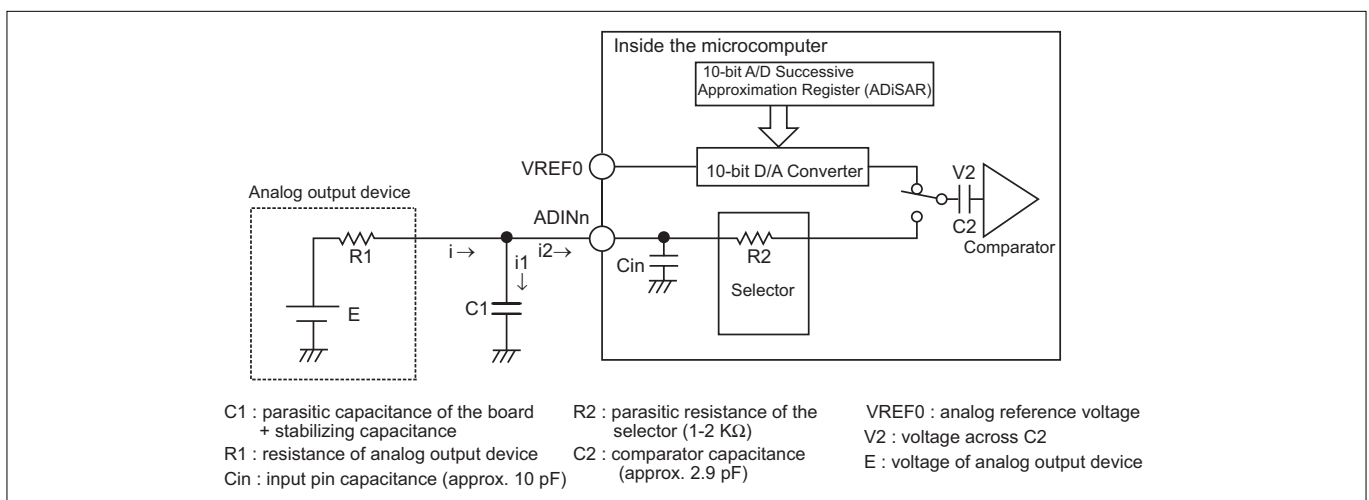


Figure 11.5.1 Internal Equivalent Circuit of the Analog Input Part

**(a) Example for calculating the external stabilizing capacitor C1 (addition of this capacitor is recommended)**

Assuming the R1 in Figure 11.5.1 is infinitely large and that the current necessary to charge the internal capacitor C2 is supplied from C1, if the potential fluctuation, Vp, caused by capacitance division of C1 and C2 is to be within 0.1 LSB, then what amount of capacitance C1 should have. For a 10-bit A/D Converter where VREF0 is 5.12 V, 1 LSB determination voltage = 5.12 V / 1,024 = 5 mV. The potential fluctuation of 0.1 LSB means a 0.5 mV fluctuation.

The relationship between the capacitance division of C1 and C2 and the potential fluctuation, Vp, is obtained by the equation below:

$$V_p = \frac{C_2}{C_1 + C_2} \times (E - V_2) \quad \text{----- Eq. A-1}$$

Vp is also obtained by the equation below:

$$V_p = V_{p1} \times \sum_{i=0}^{x-1} \frac{1}{2^i} < \frac{V_{REF0}}{10 \times 2^x} \quad \text{----- Eq. A-2}$$

where Vp1 = potential fluctuation in the first A/D conversion performed  
and x = 10 for a 10-bit resolution A/D converter

When Eq. A-1 and Eq. A-2 are solved, the following results:

$$C_1 = C_2 \left\{ \frac{E - V_2}{V_{p1}} - 1 \right\} \quad \text{----- Eq. A-3}$$

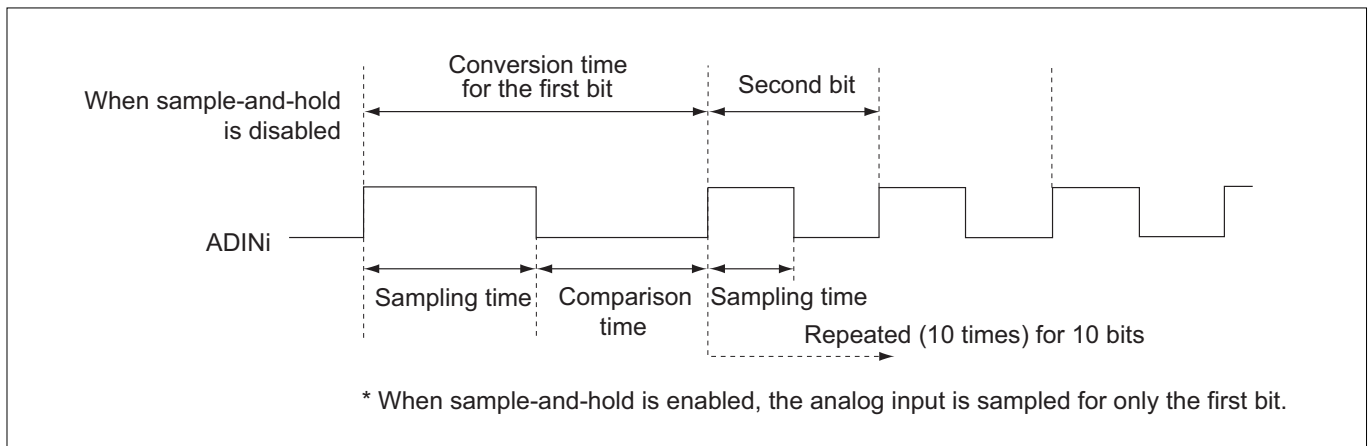
$$\therefore C_1 > C_2 \left\{ 10 \times 2^x \times \sum_{i=0}^{x-1} \frac{1}{2^i} - 1 \right\} \quad \text{----- Eq. A-4}$$

Thus, for a 10-bit resolution A/D Converter where C2 = 2.9 pF, C1 is 0.06 μF or more. Use this value for reference when setting up C1.

**(b) Maximum value of the output impedance R1 when C1 is not added**

If the external capacitor C1 in Figure 11.5.1 is not used, examination must be made to see if the analog output device can fully charge C2 within a predetermined time. First, the equation to find i2 when C1 in Figure 11.5.1 does not exist is shown below.

$$i_2 = \frac{C_2(E - V_2)}{C_{in} \times R_1 + C_2(R_1 + R_2)} \times \exp \left\{ \frac{-t}{C_{in} \times R_1 + C_2(R_1 + R_2)} \right\} \quad \text{----- Eq. B-1}$$



**Figure 11.5.2 A/D Conversion Timing Diagram**

Figure 11.5.2 shows an A/D conversion timing diagram. C2 must be charged up within the sampling time shown in this diagram. When the sample-and-hold function is disabled, the sampling time for the second and subsequent bits is about half that of the first bit.

The sampling times at the respective conversion speeds are listed in the table 11.5.1. Note that when the sample-and-hold function is enabled, the analog input is sampled for only the first bit.

**Table 11.5.1 Sampling Time (in Which C2 Needs to Be Charged)**

Conversion start method		Conversion speed		Sampling time for the first bit	Sampling time for the 2nd and subsequent bits
2BCLK mode	Single mode (when sample-and-hold disabled or normal sample-and-hod enabled)	Slow mode	Normal speed	55BCLK	27BCLK
			Double speed	31BCLK	15BCLK
		Fast mode	Normal speed	23BCLK	11BCLK
			Double speed	15BCLK	7BCLK
	Single mode (when fast sample- and-hold enabled)	Slow mode	Normal speed	55BCLK	–
			Double speed	31BCLK	–
		Fast mode	Normal speed	23BCLK	–
			Double speed	15BCLK	–
	Comparator mode	Slow mode	Normal speed	55BCLK	–
			Double speed	31BCLK	–
		Fast mode	Normal speed	23BCLK	–
			Double speed	15BCLK	–
Simultaneous sampling	Slow mode	Normal speed	55BCLK	–	
		Double speed	31BCLK	–	
	Fast mode	Normal speed	23BCLK	–	
		Double speed	15BCLK	–	

Therefore, the time in which C2 needs to be charged is found from Eq. B-1, as follows:

$$\text{Sampling time (in which C2 needs to be charged)} > C_{in} \times R1 + C2(R1 + R2) \quad \text{Eq. B-2}$$

Thus, the maximum value of R1 can be obtained as a criterion from the equation below. Note, however, that for single mode (when sample-and-hold is disabled), the sampling time for the second and subsequent bits (C2 charging time) must be applied.

$$R1 < \frac{C2 \text{ charging time} - C2 \times R2}{C_{in} + C2}$$

This page is blank for reasons of layout.

## CHAPTER 12

---

# SERIAL INTERFACE

- 12.1 Outline of Serial Interface
- 12.2 Serial Interface Related Registers
- 12.3 Transmit Operation in CSIO Mode
- 12.4 Receive Operation in CSIO Mode
- 12.5 Notes on Using CSIO Mode
- 12.6 Transmit Operation in UART Mode
- 12.7 Receive Operation in UART Mode
- 12.8 Fixed Period Clock Output Function
- 12.9 Notes on Using UART Mode

## 12.1 Outline of Serial Interface

The 32192/32195/32196 contains a total of six serial interface channels, SIO0–SIO5. Channels SIO0, SIO1, SIO4 and SIO5 can be selected between CSIO mode (clock-synchronous serial interface) and UART mode (clock-asynchronous serial interface). Channels SIO2 and SIO3 are UART mode only.

- **CSIO mode (clock-synchronous serial interface)**

Communication is performed synchronously with a transfer clock, using the same clock on both transmit and receive sides. The transfer data length can be selected within the range from 8 to 16 bits long.

- **UART mode (clock-asynchronous serial interface)**

Communication is performed at any transfer rate in any transfer data format. The transfer data length can be selected from 7, 8 and 9 bits.

Channels SIO0–SIO5 each have a transmit DMA transfer and a receive DMA transfer request. These serial interfaces, when combined with the internal DMA Controller (DMAC), allow serial communication to be performed at high speed, as well as reduce the data communication load of the CPU.

Serial interface is outlined below.

**Table 12.1.1 Outline of Serial interface**

Item	Description
Number of channels	CSIO mode/UART mode: 4 channels (SIO0, SIO1, SIO4, SIO5) UART only : 2 channels (SIO2, SIO3)
Clock	During CSIO mode : Internal clock or external clock as selected (Note 1), clock polarity can be selected During UART mode : Internal clock only
Transfer mode	Transmit half-duplex, receive half-duplex, transmit/receive full-duplex
BRG count source (when internal clock selected)	f(BCLK), f(BCLK)/8, f(BCLK)/32, f(BCLK)/256 (Note 2) f(BCLK)/2, f(BCLK)/16, f(BCLK)/64, f(BCLK)/512 f(BCLK): Peripheral clock operating frequency
Data format	CSIO mode : Data length = selectable in the range of 8–16 bits Order of transfer = selectable from LSB first or MSB first  UART mode : Start bit = 1 bit Character length = 7, 8 or 9 bits Parity bit = Added (odd, even) or not added Stop bit = 1 or 2 bits Order of transfer = selectable from LSB first or MSB first
Baud rate	CSIO mode : 152 bits/sec to 5 Mbits/sec (when f(BCLK) = 40 MHz/internal clock selected) (Note 1) Max 2.5 Mbits/sec (when f(BCLK) = 40 MHz/external clock selected) UART mode : 19 bits/sec to 2.5 Mbits/sec (when f(BCLK) = 40 MHz)
Error detection	CSIO mode : Overrun error only UART mode : Overrun, parity and framing errors (Occurrence of any of these errors is indicated by an error sum bit)
Fixed period clock BRG output function	When using SIO0, SIO1, SIO4 and SIO5 as UART mode, this function outputs a divided-by-2 clock from the SCLK pin.

Note 1: The maximum input frequency of an external clock during CSIO mode is f(BCLK)/16.

Note 2: If f(BCLK) is selected as the count source, the BRG set value is subject to limitations.

**Table 12.1.2 Interrupt Generation Functions of Serial Interface**

Serial Interface Interrupt Request Cause	ICU Interrupt Request Sources
SIO0 transmit buffer empty or transmission finished	SIO0 transmit interrupt
SIO0 reception finished or receive error	SIO0 receive interrupt
SIO1 transmit buffer empty or transmission finished	SIO1 transmit interrupt
SIO1 reception finished or receive error	SIO1 receive interrupt
SIO2 transmit buffer empty or transmission finished	SIO2,3 transmit/receive interrupt (group interrupt)
SIO2 reception finished or receive error	SIO2,3 transmit/receive interrupt (group interrupt)
SIO3 transmit buffer empty or transmission finished	SIO2,3 transmit/receive interrupt (group interrupt)
SIO3 reception finished or receive error	SIO2,3 transmit/receive interrupt (group interrupt)
SIO4 transmit buffer empty or transmission finished	SIO4,5 transmit/receive interrupt (group interrupt)
SIO4 reception finished or receive error	SIO4,5 transmit/receive interrupt (group interrupt)
SIO5 transmit buffer empty or transmission finished	SIO4,5 transmit/receive interrupt (group interrupt)
SIO5 reception finished or receive error	SIO4,5 transmit/receive interrupt (group interrupt)

Note: • The transmission-finished interrupt is effective when the internal clock is selected in UART or CSIO mode.

**Table 12.1.3 DMA Transfer Request Generation Functions of Serial Interface**

Serial Interface DMA Transfer Request	DMAC Input Channels
SIO0 transmit buffer empty	DMA3, DMA4
SIO0 reception finished	DMA4
SIO1 transmit buffer empty	DMA6
SIO1 reception finished	DMA3, DMA6
SIO2 transmit buffer empty	DMA7
SIO2 reception finished	DMA5
SIO3 transmit buffer empty	DMA7, DMA9
SIO3 reception finished	DMA8
SIO4 transmit buffer empty	DMA0
SIO4 reception finished	DMA1
SIO5 transmit buffer empty	DMA2
SIO5 reception finished	DMA3

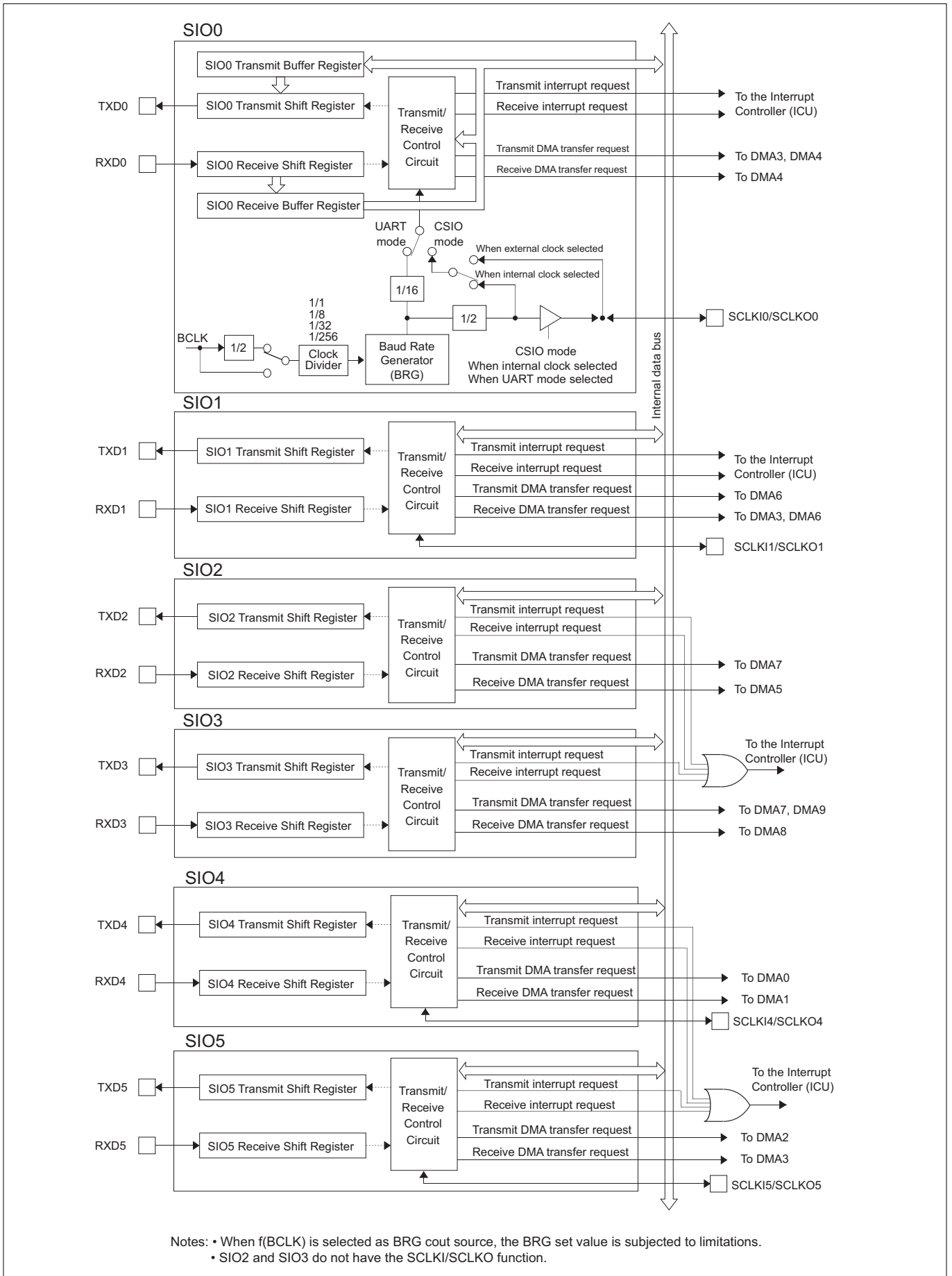


Figure 12.1.1 Block Diagram of Serial Interfaces



## 12.2 Serial Interface Related Registers

Shown below is a serial interface related register map.

Serial Interface Related Register Map (1/2)

Address	+0 address		+1 address		See pages
	b0	b7	b8	b15	
H'0080 0100	SIO23 Interrupt Request Status Register (SI23STAT)		SIO03 Interrupt Request Mask Register (SIO3MASK)		12-9 12-10
H'0080 0102	SIO03 Interrupt Request Source Select Register (SIO3SEL)		(Use inhibited area)		12-11
	(Use inhibited area)				
H'0080 0110	SIO0 Transmit Control Register (S0TCNT)		SIO0 Transmit/Receive Mode Register (S0MOD)		12-14 12-15
H'0080 0112	SIO0 Transmit Buffer Register (S0TXB)				12-19
H'0080 0114	SIO0 Receive Buffer Register (S0RXB)				12-20
H'0080 0116	SIO0 Receive Control Register (S0RCNT)		SIO0 Baud Rate Register (S0BAUR)		12-21 12-24
H'0080 0118	SIO0 Special Mode Register (S0SMOD)		(Use inhibited area)		12-27
	(Use inhibited area)				
H'0080 0120	SIO1 Transmit Control Register (S1TCNT)		SIO1 Transmit/Receive Mode Register (S1MOD)		12-14 12-15
H'0080 0122	SIO1 Transmit Buffer Register (S1TXB)				12-19
H'0080 0124	SIO1 Receive Buffer Register (S1RXB)				12-20
H'0080 0126	SIO1 Receive Control Register (S1RCNT)		SIO1 Baud Rate Register (S1BAUR)		12-21 12-24
H'0080 0128	SIO1 Special Mode Register (S1SMOD)		(Use inhibited area)		12-27
	(Use inhibited area)				
H'0080 0130	SIO2 Transmit Control Register (S2TCNT)		SIO2 Transmit/Receive Mode Register (S2MOD)		12-14 12-15
H'0080 0132	SIO2 Transmit Buffer Register (S2TXB)				12-19
H'0080 0134	SIO2 Receive Buffer Register (S2RXB)				12-20
H'0080 0136	SIO2 Receive Control Register (S2RCNT)		SIO2 Baud Rate Register (S2BAUR)		12-21 12-24
H'0080 0138	SIO2 Special Mode Register (S2SMOD)		(Use inhibited area)		12-27
	(Use inhibited area)				
H'0080 0140	SIO3 Transmit Control Register (S3TCNT)		SIO3 Transmit/Receive Mode Register (S3MOD)		12-14 12-15
H'0080 0142	SIO3 Transmit Buffer Register (S3TXB)				12-19
H'0080 0144	SIO3 Receive Buffer Register (S3RXB)				12-20
H'0080 0146	SIO3 Receive Control Register (S3RCNT)		SIO3 Baud Rate Register (S3BAUR)		12-21 12-24
H'0080 0148	SIO3 Special Mode Register (S3SMOD)		(Use inhibited area)		12-27
	(Use inhibited area)				
H'0080 0A00	SIO45 Interrupt Request Status Register (SI45STAT)		SIO45 Interrupt Request Mask Register (SI45MASK)		12-9 12-10
H'0080 0A02	SIO45 Interrupt Request Source Select Register (SI45SEL)		(Use inhibited area)		12-11
	(Use inhibited area)				
H'0080 0A10	SIO4 Transmit Control Register (S4TCNT)		SIO4 Transmit/Receive Mode Register (S4MOD)		12-14 12-15
H'0080 0A12	SIO4 Transmit Buffer Register (S4TXB)				12-19
H'0080 0A14	SIO4 Receive Buffer Register (S4RXB)				12-20
H'0080 0A16	SIO4 Receive Control Register (S4RCNT)		SIO4 Baud Rate Register (S4BAUR)		12-21 12-24

## Serial Interface Related Register Map (2/2)

Address	+0 address	+1 address	See pages
	b0	b7 b8	b15
H'0080 0A18	SIO4 Special Mode Register (S4SMOD)	(Use inhibited area)	12-27
	(Use inhibited area)		
H'0080 0A20	SIO5 Transmit Control Register (S5TCNT)	SIO5 Transmit/Receive Mode Register (S5MOD)	12-14 12-15
H'0080 0A22	SIO5 Transmit Buffer Register (S5TXB)		12-19
H'0080 0A24	SIO5 Receive Buffer Register (S5RXB)		12-20
H'0080 0A26	SIO5 Receive Control Register (S5RCNT)	SIO5 Baud Rate Register (S5BAUR)	12-21 12-24
H'0080 0A28	SIO5 Special Mode Register (S5SMOD)	(Use inhibited area)	12-27

### 12.2.1 SIO Interrupt Related Registers

The SIO interrupt related registers are used to control the interrupt request signals output from SIO to the Interrupt Controller (ICU), as well as select the source of each interrupt request.

#### (1) Interrupt request status bit

This status bit is used to determine whether an interrupt is requested. When an interrupt request occurs, this bit is set in hardware (cannot be set in software). The status bit is cleared by writing "0." Writing "1" has no effect; the bit retains the status it had before the write. Because this bit is unaffected by the interrupt request mask bit, it can also be used to inspect the operating status of peripheral functions.

In interrupt handling, make sure that within the grouped interrupt request status, only the status bit for the interrupt request that has been serviced is cleared. If the status bit for any interrupt request that has not been serviced is cleared, the pending interrupt request is cleared simultaneously with its status bit.

#### (2) Interrupt request mask bit

This bit is used to disable unnecessary interrupt requests within the grouped interrupt request. Set this bit to "1" to enable interrupt requests or "0" to disable interrupt requests.

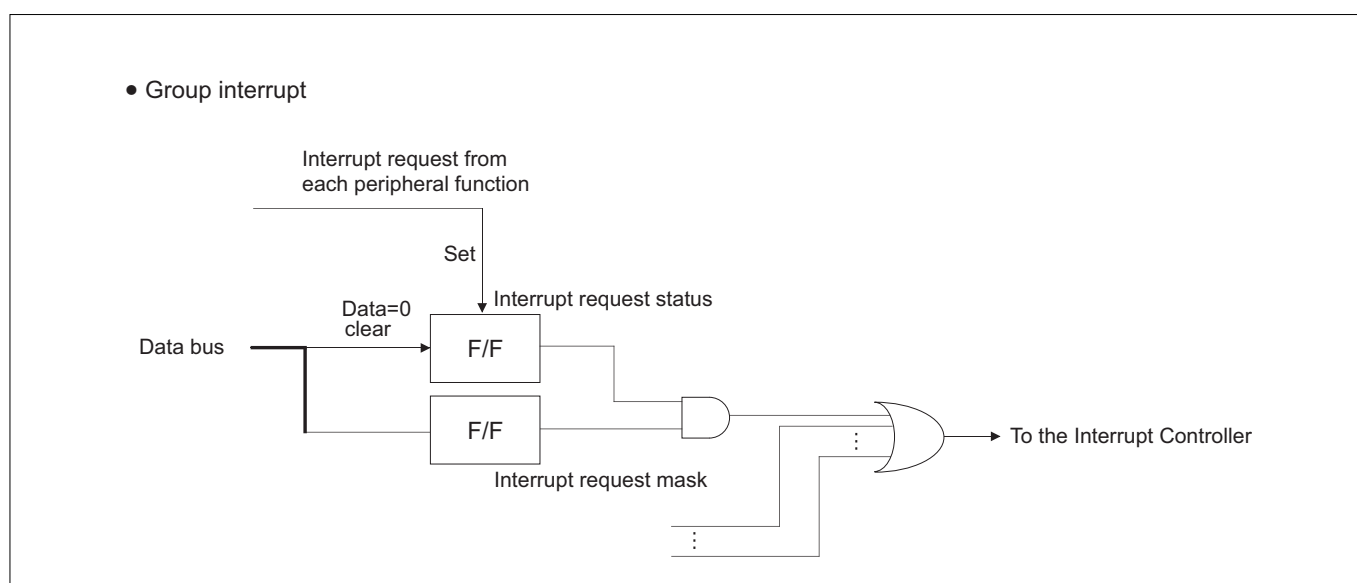
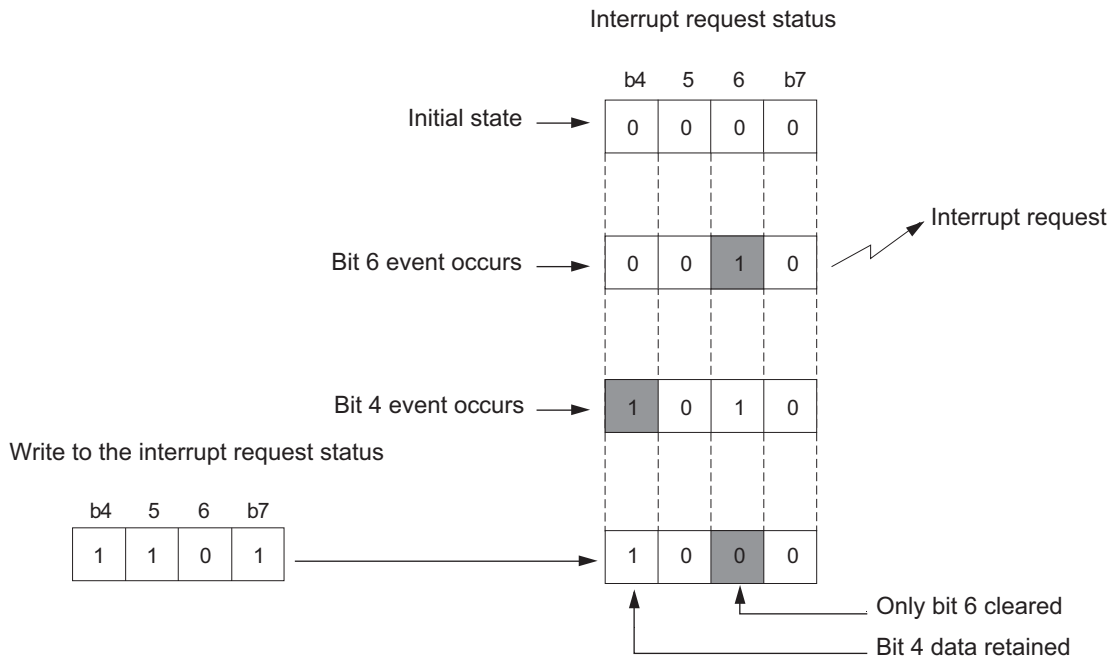


Figure 12.2.1 Interrupt Request Status and Mask Registers

● Example for clearing interrupt request status



● Program example

- To clear the Interrupt Request Status Register 0 (ISTREG) interrupt request status 1: ISTAT1 (0x02 bit)

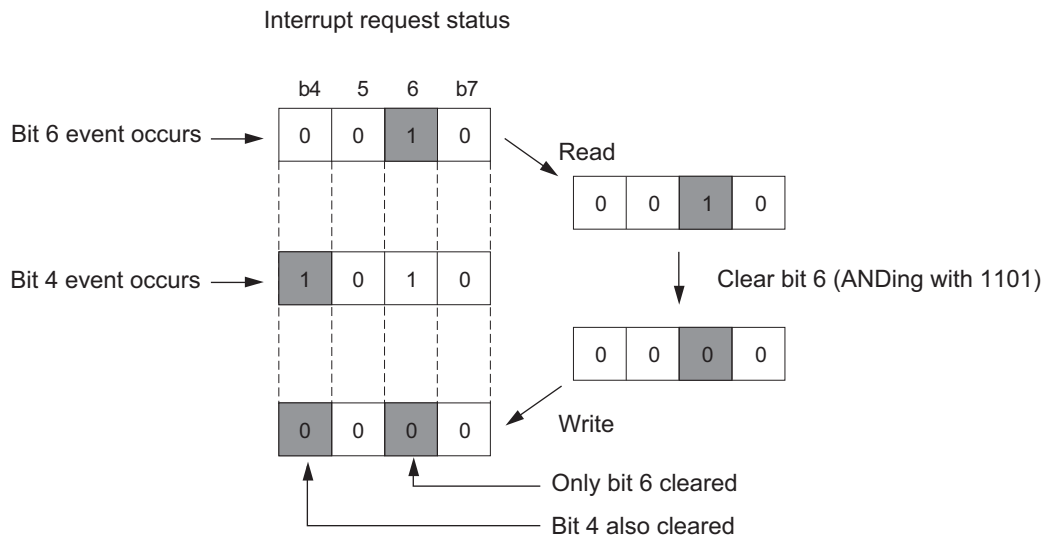


```
ISTREG = 0xfd; /* Clear ISTAT1 (0x02 bit) only */
```

To clear an interrupt request status, always be sure to write 1 to all other interrupt request status bits. At this time, avoid using a logic operation like the one shown below. Because it requires three step-ISTREG read, logic operation and write, if another interrupt request occurs between the read and write, status may be inadvertently cleared.



```
ISTREG &= 0xfd; /* Clear ISTAT1 (0x02 bit) only */
```



**Figure 12.2.2 Example for Clearing Interrupt Request Status**

#### (3) Selecting the source of an interrupt request

The interrupt request signals sent from each SIO to the Interrupt Controller (ICU) are broadly classified into transmit interrupts and receive interrupts. Transmit interrupt requests can be generated when the transmit buffer is empty or transmission is finished, and the receive interrupt requests can be generated when reception is finished or an receive error is detected, as selected by the Interrupt Request Source Select Registers (SIO3SEL, SI45SEL).

- Notes:
- No interrupt request signals are generated unless interrupts are generated by the SIO Interrupt Request Mask Register after enabling the TEN (Transmit Enable) bit or REN (Receive Enable) bit for the corresponding SIO.
  - SIO2 and SIO3 together comprise one interrupt group, so do SIO4 and SIO5.
  - The transmission-finished interrupt is effective when the internal clock is selected in UART or CSIO mode.

#### (4) Notes on using transmit interrupts

When the interrupt request is enable in SIO Interrupt Request Mask Register and the transmit buffer empty interrupt is selected in SIO Interrupt Request Source Slect Resgister, a transmit interrupt request is generated upon enabling the corresponding TEN (Transmit Enable) bit.

#### (5) About DMA transfer requests from SIO

Each SIO can generate a transmit DMA transfer and a reception-finished DMA transfer request. These DMA transfer requests can be generated by enabling each SIO's corresponding TEN (Transmit Enable) bit or REN (Receive Enable) bit. When using DMA transfers to communicate with external devices, be sure to set the DMA Controller (DMAC) before enabling the TEN or REN bit. No reception-finished DMA transfer requests are generated if a receive error occurs.

##### • Transmit DMA transfer request

Generated when the transmit buffer is empty and the TEN bit is enabled.

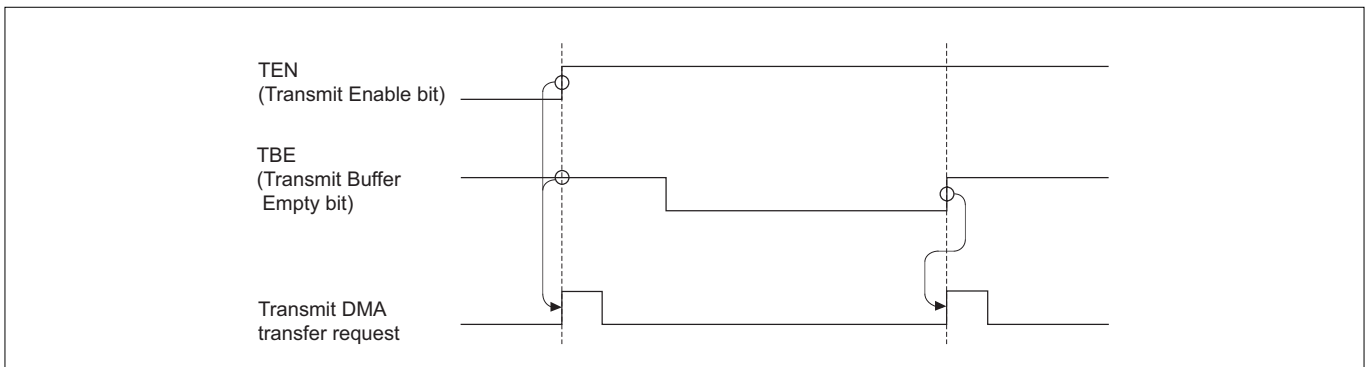


Figure 12.2.3 Transmit DMA Transfer Request

##### • Reception-finished DMA transfer request

A DMA transfer request is generated when the receive buffer is filled.

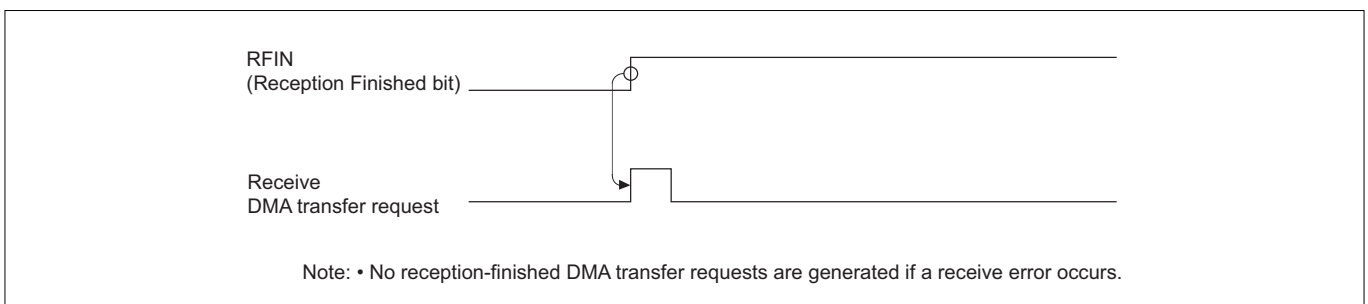


Figure 12.2.4 Reception-finished DMA Transfer Request

SIO23 Interrupt Request Status Register (SI23STAT)

&lt;Address: H'0080 0100&gt;

b0	1	2	3	4	5	6	b7
0	0	0	0	IRQT2 0	IRQR2 0	IRQT3 0	IRQR3 0

&lt;Upon exiting reset: H'00&gt;

b	Bit Name	Function	R	W
0–3	No function assigned. Fix to "0."		0	0
4	IRQT2 SIO2 transmit interrupt request status bit	0: Interrupt not requested 1: Interrupt requested	R (Note 1)	
5	IRQR2 SIO2 receive interrupt request status bit	0: Interrupt not requested 1: Interrupt requested	R (Note 1)	
6	IRQT3 SIO3 transmit interrupt request status bit	0: Interrupt not requested 1: Interrupt requested	R (Note 1)	
7	IRQR3 SIO3 receive interrupt request status bit	0: Interrupt not requested 1: Interrupt requested	R (Note 1)	

Note 1: Only writing "0" is effective. Writing "1" has no effect; the bit retains the value it had before the write.

SIO45 Interrupt Request Status Register (SI45STAT)

&lt;Address: H'0080 0A00&gt;

b0	1	2	3	4	5	6	b7
IRQT4 0	IRQR4 0	IRQT5 0	IRQR5 0	0	0	0	0

&lt;Upon exiting reset: H'00&gt;

b	Bit Name	Function	R	W
0	IRQT4 SIO4 transmit interrupt request status bit	0: Interrupt not requested 1: Interrupt requested	R (Note 1)	
1	IRQR4 SIO4 receive interrupt request status bit	0: Interrupt not requested 1: Interrupt requested	R (Note 1)	
2	IRQT5 SIO5 transmit interrupt request status bit	0: Interrupt not requested 1: Interrupt requested	R (Note 1)	
3	IRQR5 SIO5 receive interrupt request status bit	0: Interrupt not requested 1: Interrupt requested	R (Note 1)	
4–7	No function assigned. Fix to "0."		0	0

Note 1: Only writing "0" is effective. Writing "1" has no effect; the bit retains the value it had before the write.

These registers indicate the transmit/receive interrupt requests from each SIO.

**[Setting the interrupt request status bit]**

This bit can only be set in hardware, and cannot be set in software.

**[Clearing the interrupt request status bit]**

This bit is cleared by writing "0" in software.

Note: • If the status bit is set in hardware at the same time it is cleared in software, the former has priority and the status bit is set.

When writing to the SIO Interrupt Request Status Register, make sure only the bits to be cleared are set to "0" and all other bits are set to "1." Those bits that have been set to "1" are unaffected by writing in software and retain the value they had before the write.

SIO03 Interrupt Request Mask Register (SI03MASK)

&lt;Address: H'0080 0101&gt;

b8	9	10	11	12	13	14	b15
T0MASK	R0MASK	T1MASK	R1MASK	T2MASK	R2MASK	T3MASK	R3MASK
0	0	0	0	0	0	0	0

&lt;Upon exiting reset: H'00&gt;

b	Bit Name	Function	R	W
8	T0MASK SIO0 transmit interrupt request enable bit	0: Mask (disable) interrupt request 1: Enable interrupt request	R	W
9	R0MASK SIO0 receive interrupt request enable bit	0: Mask (disable) interrupt request 1: Enable interrupt request	R	W
10	T1MASK SIO1 transmit interrupt request enable bit	0: Mask (disable) interrupt request 1: Enable interrupt request	R	W
11	R1MASK SIO1 receive interrupt request enable bit	0: Mask (disable) interrupt request 1: Enable interrupt request	R	W
12	T2MASK SIO2 transmit interrupt request enable bit	0: Mask (disable) interrupt request 1: Enable interrupt request	R	W
13	R2MASK SIO2 receive interrupt request enable bit	0: Mask (disable) interrupt request 1: Enable interrupt request	R	W
14	T3MASK SIO3 transmit interrupt request enable bit	0: Mask (disable) interrupt request 1: Enable interrupt request	R	W
15	R3MASK SIO3 receive interrupt request enable bit	0: Mask (disable) interrupt request 1: Enable interrupt request	R	W

SIO45 Interrupt Request Mask Register (SI45MASK)

&lt;Address: H'0080 0A01&gt;

b8	9	10	11	12	13	14	b15
T4MASK	R4MASK	T5MASK	R5MASK				
0	0	0	0	0	0	0	0

&lt;Upon exiting reset: H'00&gt;

b	Bit Name	Function	R	W
8	T4MASK SIO4 transmit interrupt request enable bit	0: Mask (disable) interrupt request 1: Enable interrupt request	R	W
9	R4MASK SIO4 receive interrupt request enable bit	0: Mask (disable) interrupt request 1: Enable interrupt request	R	W
10	T5MASK SIO5 transmit interrupt request enable bit	0: Mask (disable) interrupt request 1: Enable interrupt request	R	W
11	R5MASK SIO5 receive interrupt request enable bit	0: Mask (disable) interrupt request 1: Enable interrupt request	R	W
12–15	No function assigned. Fix to "0."		0	0

These registers enable or disable the interrupt requests generated by each SIO. Interrupt requests from any SIO are enabled by setting its corresponding interrupt request enable bit to "1."

SIO03 Interrupt Request Source Select Register (SI03SEL)

&lt;Address: H'0080 0102&gt;

b0	1	2	3	4	5	6	b7
IST0	IST1	IST2	IST3	ISR0	ISR1	ISR2	ISR3
0	0	0	0	0	0	0	0

&lt;Upon exiting reset: H'00&gt;

b	Bit Name	Function	R	W
0	IST0 SIO0 transmit interrupt request source select bit	0: Transmit buffer empty interrupt 1: Transmission finished interrupt	R	W
1	IST1 SIO1 transmit interrupt request source select bit	0: Transmit buffer empty interrupt 1: Transmission finished interrupt	R	W
2	IST2 SIO2 transmit interrupt request source select bit	0: Transmit buffer empty interrupt 1: Transmission finished interrupt	R	W
3	IST3 SIO3 transmit interrupt request source select bit	0: Transmit buffer empty interrupt 1: Transmission finished interrupt	R	W
4	ISR0 SIO0 receive interrupt request source select bit	0: Reception finished interrupt 1: Receive error interrupt	R	W
5	ISR1 SIO1 receive interrupt request source select bit	0: Reception finished interrupt 1: Receive error interrupt	R	W
6	ISR2 SIO2 receive interrupt request source select bit	0: Reception finished interrupt 1: Receive error interrupt	R	W
7	ISR3 SIO3 receive interrupt request source select bit	0: Reception finished interrupt 1: Receive error interrupt	R	W

SIO45 Interrupt Request Source Select Register (SI45SEL)

&lt;Address: H'0080 0A02&gt;

b0	1	2	3	4	5	6	b7
IST4	IST5			ISR4	ISR5		
0	0	0	0	0	0	0	0

&lt;Upon exiting reset: H'00&gt;

b	Bit Name	Function	R	W
0	IST4 SIO4 transmit interrupt request source select bit	0: Transmit buffer empty interrupt 1: Transmission finished interrupt	R	W
1	IST5 SIO5 transmit interrupt request source select bit	0: Transmit buffer empty interrupt 1: Transmission finished interrupt	R	W
2, 3	No function assigned. Fix to "0."		0	0
4	ISR4 SIO4 receive interrupt request source select bit	0: Reception finished interrupt 1: Receive error interrupt	R	W
5	ISR5 SIO5 receive interrupt request source select bit	0: Reception finished interrupt 1: Receive error interrupt	R	W
6, 7	No function assigned. Fix to "0."		0	0

These registers select the source of interrupt requests generated by each SIO when transmit or receive operation is completed.

**(1) SIO transmit interrupt request source select bit****[When set to "0"]**

The transmit buffer empty interrupt is selected. A transmit buffer empty interrupt request is generated when data is transferred from the transmit buffer register to the transmit shift register. Also, a transmit buffer empty interrupt request is generated when the TEN (Transmit Enable) bit is set to "1" (interrupt enabled).

**[When set to "1"]**

The transmission finished (transmit shift buffer empty) interrupt is selected. A transmission finished interrupt request is generated when all of the data in the transmit shift register has been transferred.

Note: • Do not select the transmission finished interrupt when an external clock is selected in CSIO mode.

**(2) SIO receive interrupt request source select bit****[When set to "0"]**

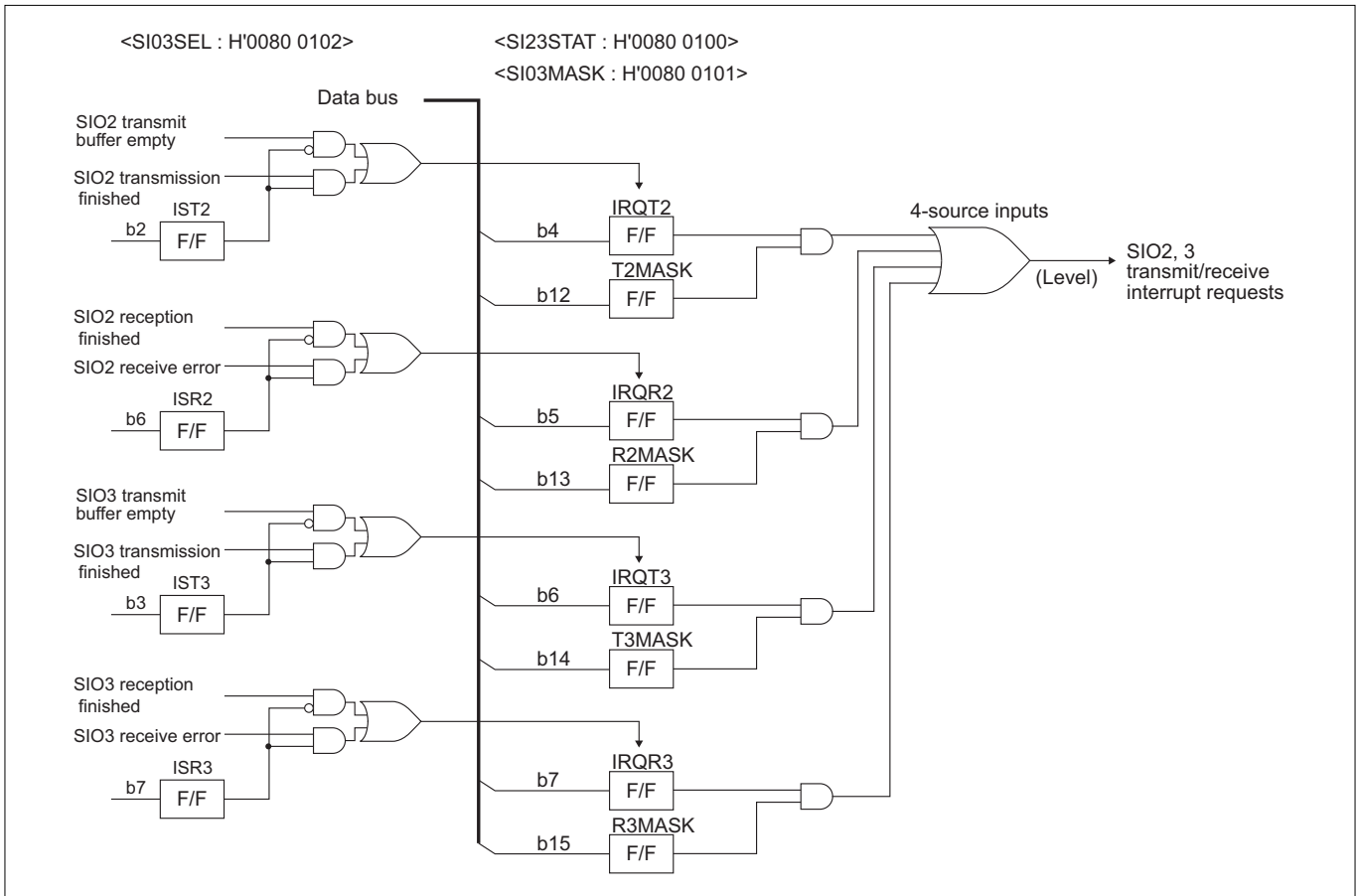
The reception finished (receive buffer full) interrupt is selected. A reception finished interrupt request is also generated when a receive error (except overrun error) occurs.

**[When set to "1"]**

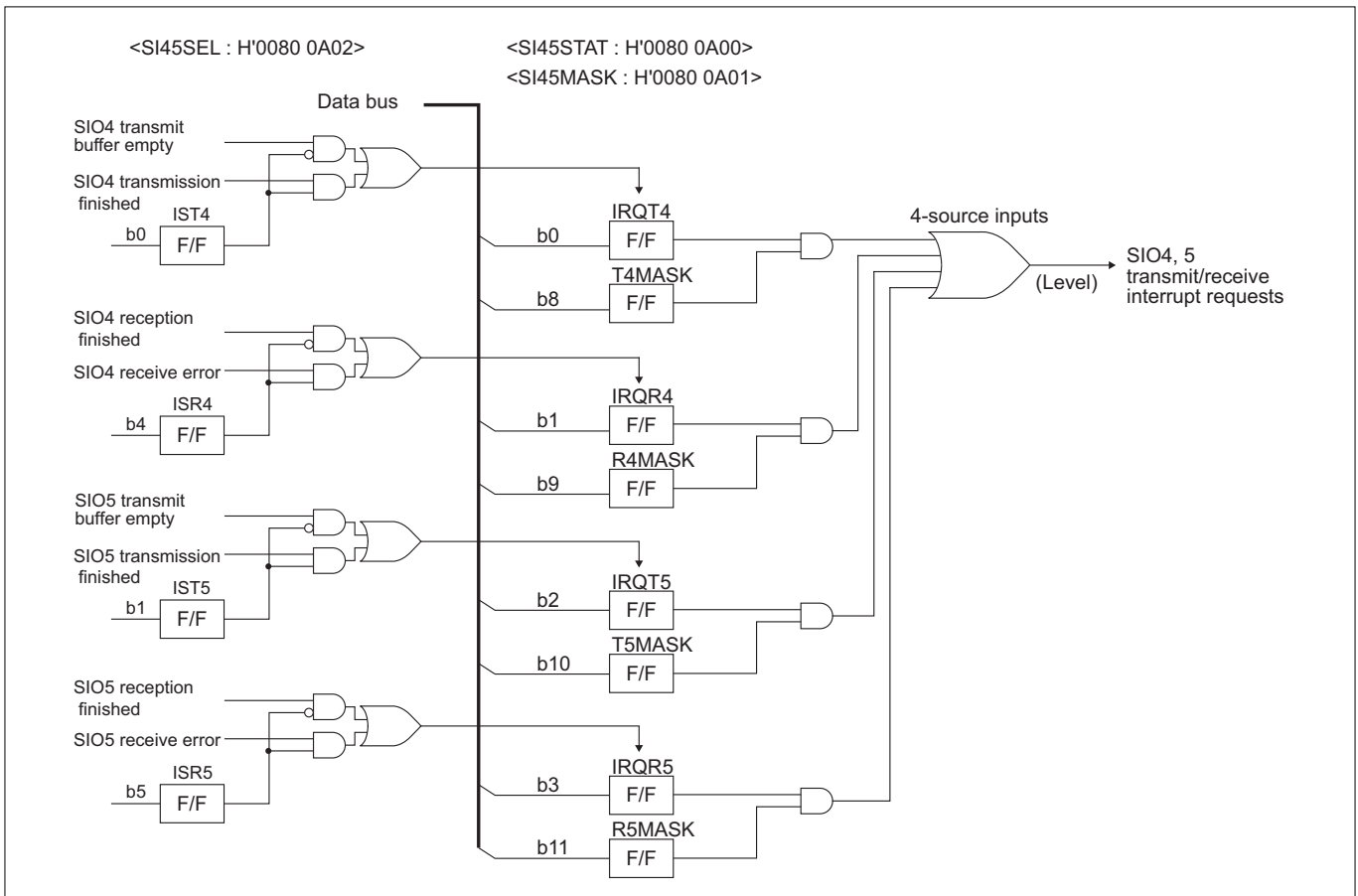
The receive error interrupt is selected. Following types of errors constitute a receive error:

- CSIO mode: Overrun error
- UART mode: Overrun, parity and framing errors





**Figure 12.2.5 Block Diagram of SIO2,3 Transmit Interrupt Requests**



**Figure 12.2.6 Block Diagram of SIO4,5 Transmit Interrupt Requests**

## 12.2.2 SIO Transmit Control Registers

SIO0 Transmit Control Register (S0TCNT)	<Address: H'0080 0110>
SIO1 Transmit Control Register (S1TCNT)	<Address: H'0080 0120>
SIO2 Transmit Control Register (S2TCNT)	<Address: H'0080 0130>
SIO3 Transmit Control Register (S3TCNT)	<Address: H'0080 0140>
SIO4 Transmit Control Register (S4TCNT)	<Address: H'0080 0A10>
SIO5 Transmit Control Register (S5TCNT)	<Address: H'0080 0A20>

b0	1	2	3	4	5	6	b7
0	0	CDIV		0	TSTAT	TBE	TEN
		0	1		0	1	0

&lt;Upon exiting reset: H'12&gt;

b	Bit Name	Function	R	W
0, 1	No function assigned. Fix to "0."		0	0
2, 3	CDIV BRG count source select bit	b2 b3 (Note 1) 0 0: Select f(BCLK) or f(BCLK)/2 0 1: Select f(BCLK) or f(BCLK)/2 divided by 8 1 0: Select f(BCLK) or f(BCLK)/2 divided by 32 1 1: Select f(BCLK) or f(BCLK)/2 divided by 256	R	W
4	No function assigned. Fix to "0."		0	0
5	TSTAT Transmit status bit	0: Transmission stopped and no data in transmit buffer register 1: Transmitting now or data present in transmit buffer register	R	–
6	TBE Transmit buffer empty bit	0: Data present in transmit buffer register 1: No data in transmit buffer register	R	–
7	TEN Transmit enable bit	0: Disable transmission 1: Enable transmission	R	W

Note 1: The selection between f(BCLK) and f(BCLK)/2 is made with the SIO Special Mode Register (SnSMOD).

**(1) CDIV (BRG count source select) bits (Bits 2 and 3)**

These bits select the count source for BRG (the Baud Rate Generator).

**(2) TSTAT (Transmit Status) bit (Bit 5)****[Set condition]**

This bit is set to "1" by a write to the transmit buffer register while transmission is enabled.

**[Clear condition]**

This bit is cleared to "0" when transmission is idle (no data in the transmit shift register) and no data exists in the transmit buffer register. This bit is also cleared by clearing the transmit enable bit.

**(3) TBE (Transmit Buffer Empty) bit (Bit 6)****[Set condition]**

This bit is set to "1" when data is transferred from the transmit buffer register to the transmit shift register and the transmit buffer register is thereby emptied. This bit is also set by clearing the transmit enable bit to "0."

**[Clear condition]**

This bit is cleared to "0" by writing data to the lower byte of the transmit buffer register while transmission is enabled (TEN = "1").

**(4) TEN (Transmit Enable) bit (Bit 7)**

Transmission is enabled by setting this bit to "1" and disabled by clearing this bit to "0." If this bit is cleared to "0" while transmitting data, the transmit operation stops.

### 12.2.3 SIO Transmit/Receive Mode Registers

SIO0 Transmit/Receive Mode Register (S0MOD)	<Address: H'0080 0111>
SIO1 Transmit/Receive Mode Register (S1MOD)	<Address: H'0080 0121>
SIO2 Transmit/Receive Mode Register (S2MOD)	<Address: H'0080 0131>
SIO3 Transmit/Receive Mode Register (S3MOD)	<Address: H'0080 0141>
SIO4 Transmit/Receive Mode Register (S4MOD)	<Address: H'0080 0A11>
SIO5 Transmit/Receive Mode Register (S5MOD)	<Address: H'0080 0A21>

b8	9	10	11	12	13	14	b15
SMOD			CKS	STB	PSEL	PEN	SEN
0	0	0	0	0	0	0	0

&lt;Upon exiting reset: H'00&gt;

b	Bit Name	Function	R	W
8–10	SMOD Serial interface mode select bit (Note 1)	b8 b9 b10 0 0 0 : 7-bit UART 0 0 1 : 8-bit UART 0 1 X : 9-bit UART 1 X X : 8–16-bit CSIO (Note 4)	R	W
11	CKS Internal/external clock select bit	0: Internal clock 1: External clock	R	W (Note 2)
12	STB Stop bit length select bit, UART mode only	0: One stop bit 1: Two stop bits	R	W (Note 3)
13	PSEL Odd/even parity select bit, UART mode only	0: Odd parity 1: Even parity	R	W (Note 3)
14	PEN Parity enable bit, UART mode only	0: Disable parity 1: Enable parity	R	W (Note 3)
15	SEN Sleep select bit, UART mode only	0: Disable sleep function 1: Enable sleep function	R	W (Note 3)

Note 1: For SIO2 and 3, bit 8 is fixed to "0" in hardware. This bit cannot be set to "1" in software (to select clock-synchronous serial interface).

Note 2: Has no effect when UART mode selected.

Note 3: Bits 12–15 have no effect during clock-synchronous mode.

Note 4: The selection of CSIO bit length is made with the SIO<sub>n</sub> Special Mode Register (SnSMOD).

The SIO Transmit/Receive Mode Registers consist of bits to set the serial interface operation mode, data format and the functions used during communication.

The SIO Transmit/Receive Mode Registers must always be set before the serial interface starts operating. To change register settings after the serial interface starts sending or receiving data, first confirm that transmit and receive operations have finished and then disable transmit/receive operations (by clearing the SIO Transmit Control Register transmit enable bit and SIO Receive Control Register receive enable bit to "0") before making changes.

#### (1) SMOD (Serial Interface Mode Select) bits (Bits 8–10)

These bits select the operation mode of serial interface.

#### (2) CKS (Internal/External Clock Select) bit (Bit 11)

This bit is effective when CSIO mode is selected. Setting this bit has no effect when UART mode is selected, in which case the serial interface is clocked by the internal clock.

**(3) STB (Stop Bit Length Select) bit (Bit 12)**

This bit is effective during UART mode. Use this bit to select the stop bit length that indicates the end of data to transmit. Setting this bit to "0" selects one stop bit, and setting this bit to "1" selects two stop bits.

During clock-synchronous mode, the content of this bit has no effect.

**(4) PSEL (Odd/Even Parity Select) bit (Bit 13)**

This bit is effective during UART mode. When parity is enabled (bit 14 = "1"), use this bit to select the parity attribute (whether odd or even). Setting this bit to "0" selects an odd parity, and setting this bit to "1" selects an even parity.

When parity is disabled (bit 14 = "0") and during clock-synchronous mode, the content of this bit has no effect.

**(5) PEN (Parity Enable) bit (Bit 14)**

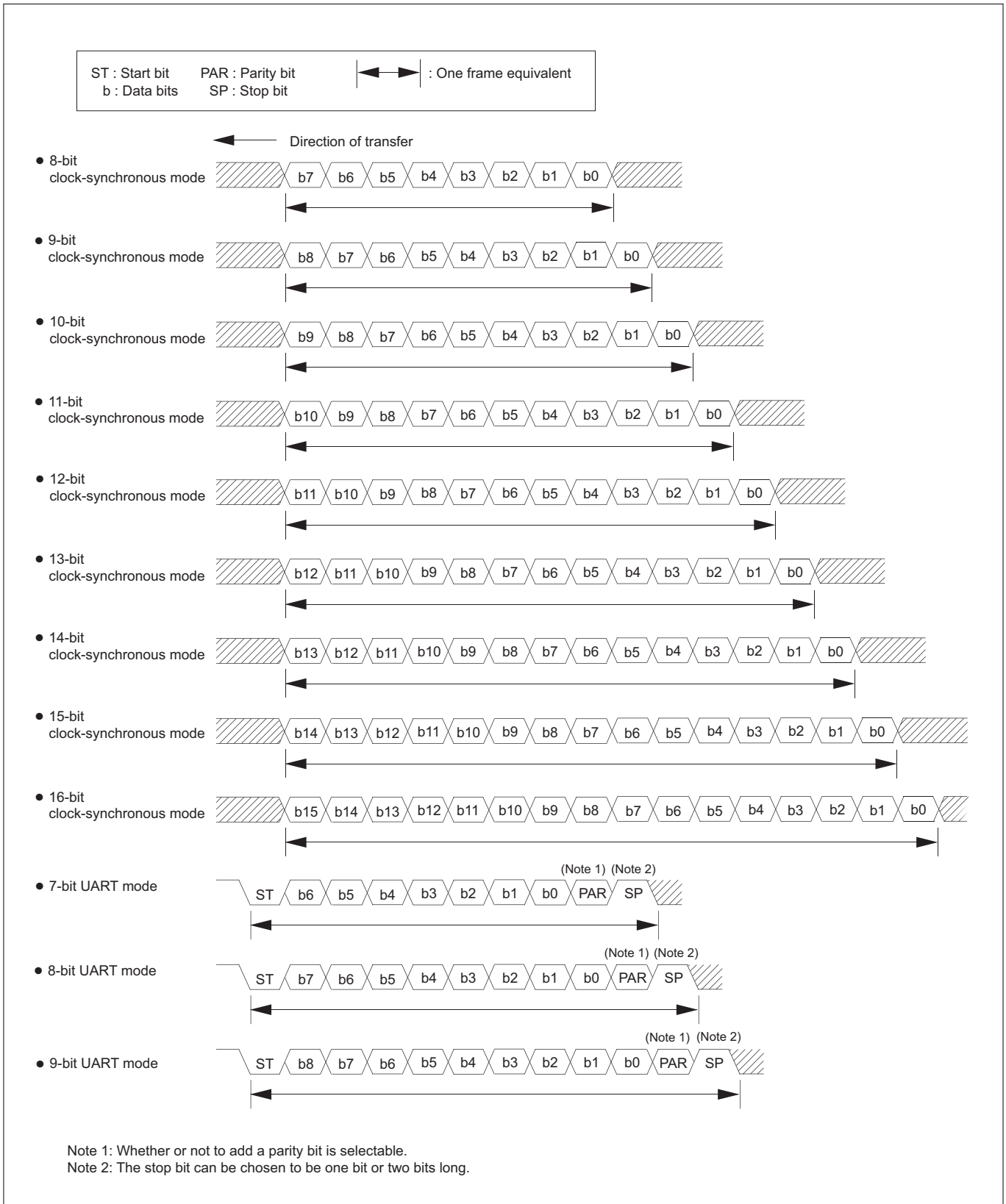
This bit is effective during UART mode. When this bit is set to "1," a parity bit is added immediately after the data bits of the transmit data, and the received data is checked for parity.

The parity bit added to the transmit data is automatically determined to be "0" or "1" so that the attribute (odd/even) derived by adding the number of 1's in data bits and the content of the parity bit agrees with one that was selected with the odd/even parity select bit (bit 13).

Figure 12.2.7 shows an example of a data format when parity is enabled.

**(6) SEN (Sleep Select) bit (Bit 15)**

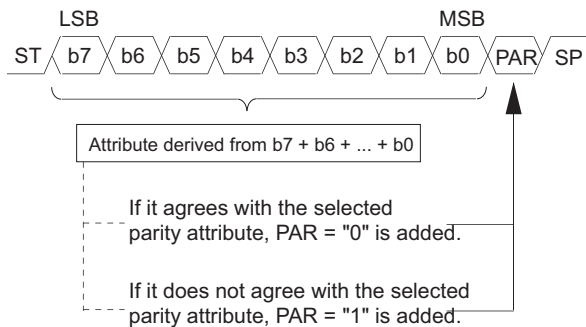
This bit is effective during UART mode. If the sleep function is enabled by setting this bit to "1," data is latched into the UART Receive Buffer Register only when the most significant bit (MSB) of the received data is "1."



**Figure 12.2.7 Data Format When Parity is Enabled (1/2)**

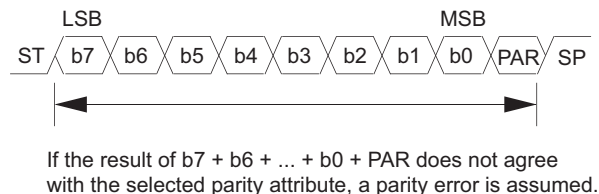
- When transmitting

If the attribute (odd/even) represented by the number of 1's in data bits agrees with the selected parity attribute, a parity bit "0" is added. If the attribute (odd/even) represented by the number of 1's in data bits does not agree with the selected parity attribute, a parity bit "1" is added.



- When receiving

The received data is checked to see if the number of 1's included in its data and parity bits agrees with the parity attribute (known as parity check).

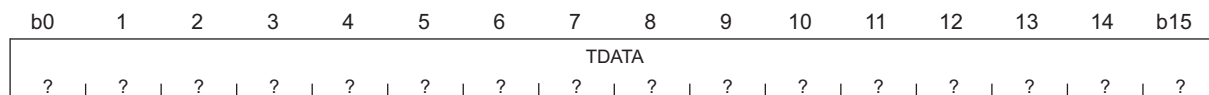


Notes : • Shown above is an example of a data format in 8-bit UART mode.  
 • The data bit numbers (bn) above indicate bit numbers in a data list, and not the register bit numbers (bn).

Figure 12.2.8 Data Format When Parity is Enabled (2/2)

## 12.2.4 SIO Transmit Buffer Registers

SIO0 Transmit Buffer Register (S0TXB)	<Address: H'0080 0112>
SIO1 Transmit Buffer Register (S1TXB)	<Address: H'0080 0122>
SIO2 Transmit Buffer Register (S2TXB)	<Address: H'0080 0132>
SIO3 Transmit Buffer Register (S3TXB)	<Address: H'0080 0142>
SIO4 Transmit Buffer Register (S4TXB)	<Address: H'0080 0A12>
SIO5 Transmit Buffer Register (S5TXB)	<Address: H'0080 0A22>



&lt;Upon exiting reset: Undefined&gt;

b	Bit Name	Function	R	W
0–15	TDATA Transmit data	Transmit data is set in these bits.	R	W

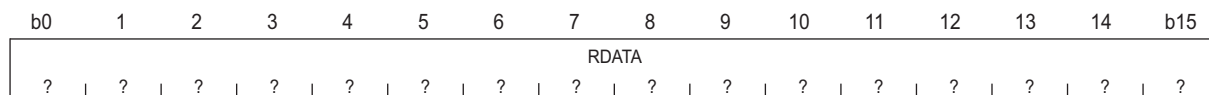
The SIO Transmit Buffer Registers are used to set transmit data. The write value of these registers can be read out. Data must be LSB-aligned when write a transmit data. According to the conditions of the serial interface mode select bit, the CSIO bit length select bit and the transfer order select bit, the data corresponding to the specified bit is transmitted from the LSB or MSB side.

Before setting transmit data in these registers, enable the Transmit Control Register TEN (Transmit Enable) bit by setting it to "1." Writing data to these registers while the TEN bit is disabled (cleared to "0") has no effect. When data is written to the SIO Transmit Buffer Register while transmission is enabled, the data is transferred from that register to the SIO Transmit Shift Register, upon which the serial interface starts sending data.

Note: • For the 7-bit and 8-bit data formats, the register can be accessed bitwise.

## 12.2.5 SIO Receive Buffer Registers

SIO0 Receive Buffer Register (S0RXB)	<Address: H'0080 0114>
SIO1 Receive Buffer Register (S1RXB)	<Address: H'0080 0124>
SIO2 Receive Buffer Register (S2RXB)	<Address: H'0080 0134>
SIO3 Receive Buffer Register (S3RXB)	<Address: H'0080 0144>
SIO4 Receive Buffer Register (S4RXB)	<Address: H'0080 0A14>
SIO5 Receive Buffer Register (S5RXB)	<Address: H'0080 0A24>



&lt;Upon exiting reset: Undefined&gt;

b	Bit Name	Function	R	W
0–15	RDATA Received data	Received data is stored in these bits.	R	–

The SIO Receive Buffer Registers are used to store the received data. When the serial interface has finished receiving data, the content of the SIO Receive Shift Register is transferred to the SIO Receive Buffer Register. These registers are a read-only register.

Data must be LSB-aligned when latching a received data.

According to the conditions of the serial interface mode select bit, the CSIO bit length select bit and the transfer order select bit, the data corresponding to the specified bit is received from the LSB or MSB side and an unused MSB side bit is set to "0."

When reading the content of the SIO Receive Buffer Register after reception is completed, if the serial interface finishes receiving the next data before the previous data is not read out, an overrun error occurs and the subsequent received data are not transferred to the Receive Buffer Register.

To restart normal receive operation, clear the Receive Control Register REN (Receive Enable) bit to "0."

Note: • For the 7-bit and 8-bit data formats, the register can be accessed byte-wise.



## 12.2.6 SIO Receive Control Registers

SIO0 Receive Control Register (S0RCNT)	<Address: H'0080 0116>
SIO1 Receive Control Register (S1RCNT)	<Address: H'0080 0126>
SIO2 Receive Control Register (S2RCNT)	<Address: H'0080 0136>
SIO3 Receive Control Register (S3RCNT)	<Address: H'0080 0146>
SIO4 Receive Control Register (S4RCNT)	<Address: H'0080 0A16>
SIO5 Receive Control Register (S5RCNT)	<Address: H'0080 0A26>

b0	1	2	3	4	5	6	b7
0	RSTAT	RFIN	REN	OVR	PTY	FLM	ERS
0	0	0	0	0	0	0	0

&lt;Upon exiting reset: H'00&gt;

b	Bit Name	Function	R	W
0	No function assigned. Fix to "0."		0	0
1	RSTAT Receive status bit	0: Reception stopped 1: Reception in progress	R	-
2	RFIN Reception finished bit	0: No data in receive buffer register 1: Data present in receive buffer register	R	-
3	REN Receive enable bit	0: Disable reception 1: Enable reception	R	W
4	OVR Overrun error bit	0: No overrun error 1: Overrun error occurred	R	-
5	PTY Parity error bit, UART mode only	0: No parity error 1: Parity error occurred	R	-
6	FLM Framing error bit, UART mode only	0: No framing error 1: Framing error occurred	R	-
7	ERS Error sum bit	0: No error 1: Error occurred	R	-

**(1) RSTAT (Receive Status) bit (Bit 1)****[Set condition]**

This bit is set to "1" by a start of receive operation. When this bit = "1," the serial interface is receiving data.

**[Clear condition]**

This bit is cleared upon completion of receive operation or by clearing the REN (Receive Enable) bit to "0."

**(2) RFIN (Reception Finished) bit (Bit 2)****[Set condition]**

This bit is set to "1" when all data bits have been received in the Receive Shift Register and whose content is transferred to the Receive Buffer Register.

**[Clear condition]**

This bit is cleared to "0" by reading out the lower byte of the Receive Buffer Register or by clearing the REN (Receive Enable) bit. However, if an overrun error occurs, this bit cannot be cleared by reading out the lower byte of the Receive Buffer Register. In this case, clear REN (Receive Enable) bit to "0."

**(3) REN (Receive Enable) bit (Bit 3)**

Reception is enabled by setting this bit to "1," and is disabled by clearing this bit to "0," in which case the receiver unit is initialized. Accordingly, the receive status and reception finished bits, as well as the overrun error, framing error, parity error and error sum bits all are cleared.

The receive operation stops if the Receive Enable bit is cleared to "0" while receiving data.

**(4) OVR (Overrun Error) bit (Bit 4)**

When an overrun error occurs, the received data is not stored in the Receive Buffer Register. In this case, neither an interrupt request nor a DMA transfer request by receive completion occurs.

**[Set condition]**

This bit is set to "1" when all bits of the next received data have been set in the Receive Shift Register while the Receive Buffer Register still contains the previous received data. Although receive operation continues even when the overrun error flag = "1," the received data is not stored in the Receive Buffer Register. This error bit must be cleared before normal reception can be restarted.

**[Clear condition]**

This bit is cleared by only clearing the REN (Receive Enable) bit to "0."

**(5) PTY (Parity Error) bit (Bit 5)**

This bit is effective in only UART mode. It is fixed to "0" during CSIO mode. When a parity error occurs, the received data is stored in the Receive Buffer Register. In this case, an interrupt request by receive completion occurs but a DMA transfer request does not occur.

**[Set condition]**

The PTY (Parity Error) bit is set to "1" when the SIO Transmit/Receive Mode Register PEN (Parity Enable/Disable) bit is enabled and the parity (even or odd) of the received data does not agree with one that was set by the said register's PSEL (Parity Select) bit.

**[Clear condition]**

The PTY bit is cleared to "0" by reading out the lower byte of the SIO Receive Buffer Register or by clearing the SIO Receive Control Register REN (Receive Enable) bit. However, if an overrun error occurs, this bit cannot be cleared by reading out the lower byte of the Receive Buffer Register. In this case, clear the REN (Receive Enable) bit to "0."

**(6) FLM (Framing Error) bit (Bit 6)**

This bit is effective in only UART mode. It is fixed to "0" during CSIO mode. When a framing error occurs, the received data is stored in the Receive Buffer Register. In this case, an interrupt request by receive completion occurs but a DMA transfer request does not occur.

**[Set condition]**

The FLM (Framing Error) bit is set to "1" when the number of received bits does not agree with one that was set by the SIO Transmit/Receive Mode Register.

**[Clear condition]**

The FLM bit is cleared to "0" by reading out the lower byte of the SIO Receive Buffer Register or by clearing the SIO Receive Control Register REN (Receive Enable) bit.

However, if an overrun error occurs, this bit cannot be cleared by reading out the lower byte of the Receive Buffer Register. In this case, clear the REN (Receive Enable) bit to "0."

**(7) ERS (Error Sum) bit (Bit 7)****[Set condition]**

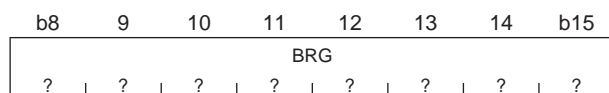
This bit is set to "1" when any one of overrun, framing or parity errors is detected at completion of reception.

**[Clear condition]**

If the detected error was an overrun error, this bit is cleared by clearing the REN (Receive Enable) bit to "0." Otherwise, this flag is cleared by reading out the lower byte of the SIO Receive Buffer Register or by clearing the SIO Receive Control Register REN (Receive Enable) bit.

### 12.2.7 SIO Baud Rate Registers

SIO0 Baud Rate Register (S0BAUR)	<Address: H'0080 0117>
SIO1 Baud Rate Register (S1BAUR)	<Address: H'0080 0127>
SIO2 Baud Rate Register (S2BAUR)	<Address: H'0080 0137>
SIO3 Baud Rate Register (S3BAUR)	<Address: H'0080 0147>
SIO4 Baud Rate Register (S4BAUR)	<Address: H'0080 0A17>
SIO5 Baud Rate Register (S5BAUR)	<Address: H'0080 0A27>



<Upon exiting reset: Undefined>

b	Bit Name	Function	R	W
8–15	BRG Baud rate divide value	Baud rate divide value is set in these bits	R	W

#### (1) BRG (baud rate divide value) (Bits 8–15)

The SIO Baud Rate Registers are used to set a baud rate divide value, so that the BRG count source selected by SIO Transmit Control Register is divided by (n + 1) where n = BRG set value.

Because the BRG value initially is undefined, be sure to set the divide value before the serial interface starts operating. The value written to the BRG during transmit/receive operation takes effect in the next cycle after the BRG counter has finished counting.

When using the internal clock (to output the SCLKO signal) in CSIO mode, the serial interface divides the clock divider count source using a clock divider and then divides the resulting clock by (n + 1) where n = BRG set value and further by 2, thereby generating a transmit/receive shift clock.

When using an external clock in CSIO mode, the serial interface does not use the BRG. (Transmit/receive operations are synchronized to the externally supplied clock.)

During UART mode, the serial interface divides the clock divider count source using a clock divider and then divides the resulting clock by (n + 1) where n = BRG set value and further by 16, thereby generating a transmit/receive shift clock.

When using SIO0, SIO1, SIO4 or SIO5 in UART mode, set the relevant port to function as an SCLKO pin, so that a BRG output clock divided by 2 can be output from that SCLKO pin.

During internal clock CSIO mode, make sure the transfer rate does not exceed  $f(\text{BCLK})/8$ .

The baud rate register set value when internal clock CSIO mode is selected can be calculated by the following equations.

#### • CSIO Mode

$$\text{SIO Baud Rate Register Set Value} = \frac{\text{Clock Divider Count Source}}{\text{Baud Rate} \times \text{Clock Divider Divide Value} \times 2} - 1$$

#### • UART Mode

$$\text{SIO Baud Rate Register Set Value} = \frac{\text{Clock Divider Count Source}}{\text{Baud Rate} \times \text{Clock Divider Divide Value} \times 16} - 1$$

Clock divider count source: selected between  $f(\text{BCLK})$  and  $f(\text{BCLK})/2$  by setting the SIO Special Mode Register clock divider count source select bit.

Clock divider divide value: selected among 1, 8, 32 and 256 by setting the SIO Transmit Control Register BRG count source select bit.

Table 12.2.1 Example Settings of the SIO Baud Rate Register (CSIO Mode) (1/2)

Items Baud rate [bps]	When clock divider count source = 16MHz			When clock divider count source = 20MHz		
	Clock divider divide value [divided-by n]	BRG set value	Actual baud rate [bps]	Clock divider divide value [divided-by n]	BRG set value	Actual baud rate [bps]
250	256	124	250.00	256	155	250.40
500	256	62	496.03	256	77	500.80
1000	32	249	1000.00	256	38	1001.60
2500	32	99	2500.00	32	124	2500.00
5000	32	49	5000.00	8	249	5000.00
10000	32	24	10000.00	8	124	10000.00
25000	32	9	25000.00	8	49	25000.00
50000	32	4	50000.00	1	199	50000.00
100000	8	9	100000.00	1	99	100000.00
250000	1	31	250000.00	1	39	250000.00
500000	1	15	500000.00	1	19	500000.00
1000000	1	7	1000000.00	1	9	1000000.00
2500000	-	-	-	1	3	2500000.00
5000000	1	1	4000000.00	1	1	5000000.00

Notes: • This does not mean that the communication at the above baud rates is guaranteed. Careful consideration and inspection under your environment are required before use.  
 • Select clock divider count source in SELCLK bit of SIO special mode register (SnSMOD).  
 • Select divide-by value of clock divider in the CDIV bit of SIO transmit control register (SnTCNT).  
 • Set BRG set value in the SIO baud rate register (SnBAUR).

Table 12.2.1 Example Settings of the SIO Baud Rate Register (CSIO Mode) (2/2)

Items Baud rate [bps]	When clock divider count source = 32MHz			When clock divider count source = 40MHz		
	Clock divider divide value [divided-by n]	BRG set value	Actual baud rate [bps]	Clock divider divide value [divided-by n]	BRG set value	Actual baud rate [bps]
250	256	249	250.00	-	-	-
500	256	124	500.00	256	155	500.80
1000	256	62	992.06	256	77	1001.60
2500	32	199	2500.00	32	249	2500.00
5000	32	99	5000.00	32	124	5000.00
10000	32	49	10000.00	8	249	10000.00
25000	32	19	25000.00	8	99	25000.00
50000	32	9	50000.00	8	49	50000.00
100000	8	19	100000.00	1	199	100000.00
250000	1	63	250000.00	1	79	250000.00
500000	1	31	500000.00	1	39	500000.00
1000000	1	15	1000000.00	1	19	1000000.00
2500000	-	-	-	1	7	2500000.00
5000000	-	-	-	1	3	5000000.00

Notes: • This does not mean that the communication at the above baud rates is guaranteed. Careful consideration and inspection under your environment are required before use.  
 • Select clock divider count source in SELCLK bit of SIO special mode register (SnSMOD).  
 • Select divide-by value of clock divider in the CDIV bit of SIO transmit control register (SnTCNT).  
 • Set BRG set value in the SIO baud rate register (SnBAUR).

Table 12.2.2 Example Settings of the SIO Baud Rate Register (UART Mode) (1/2)

Baud rate [bps]	Items	When clock divider count source = 16MHz				When clock divider count source = 20MHz			
		Clock divider divide value [divided-by n]	BRG set value	Error [%]	Actual baud rate [bps]	Clock divider divide value [divided-by n]	BRG set value	Error [%]	Actual baud rate [bps]
300		32	103	0.16	300.48	32	129	0.16	300.48
600		32	51	0.16	600.96	32	64	0.16	600.96
1200		32	25	0.16	1201.92	8	129	0.16	1201.92
2400		32	12	0.16	2403.85	8	64	0.16	2403.85
4800		1	207	0.16	4807.69	8	32	-1.36	4734.85
9600		1	103	0.16	9615.38	1	129	0.16	9615.38
12500		1	79	0.00	12500.00	1	99	0.00	12500.00
14400		1	68	0.64	14492.75	1	86	-0.22	14367.82
19200		1	51	0.16	19230.77	1	64	0.16	19230.77
28800		1	34	-0.79	28571.43	1	42	0.94	29069.77
31250		1	31	0.00	31250.00	1	39	0.00	31250.00
38400		1	25	0.16	38461.54	1	32	-1.36	37878.79
57600		1	16	2.12	58823.53	1	21	-1.36	56818.18
62500		1	15	0.00	62500.00	1	19	0.00	62500.00
115200		1	8	-3.55	111111.11	1	10	-1.36	113636.36
125000		1	7	0.00	125000.00	1	9	0.00	125000.00
250000		1	3	0.00	250000.00	1	4	0.00	250000.00
500000		1	1	0.00	500000.00	1	2	-16.67	416666.67
625000		-	-	-	-	1	1	0.00	625000.00
1000000		1	0	0.00	1000000.00	-	-	-	-
1250000		-	-	-	-	1	0	0.00	1250000.00

Notes: • This does not mean that the communication at the above baud rates is guaranteed. Careful consideration and inspection under your environment are required before use.

- Select clock divider count source in SELCLK bit of SIO special mode register (SnSMOD).
- Select divide-by value of clock divider in the CDIV bit of SIO transmit control register (SnTCNT).
- Set BRG set value in the SIO baud rate register (SnBAUR).

Table 12.2.2 Example Settings of the SIO Baud Rate Register (UART Mode) (2/2)

Baud rate [bps]	Items	When clock divider count source = 32MHz				When clock divider count source = 40MHz			
		Clock divider divide value [divided-by n]	BRG set value	Error [%]	Actual baud rate [bps]	Clock divider divide value [divided-by n]	BRG set value	Error [%]	Actual baud rate [bps]
300		256	25	0.16	300.48	256	32	-1.36	295.93
600		256	12	0.16	600.96	32	129	0.16	600.96
1200		32	51	0.16	1201.92	32	64	0.16	1201.92
2400		32	25	0.16	2403.85	8	129	0.16	2403.85
4800		32	12	0.16	4807.69	8	64	0.16	4807.69
9600		8	25	0.16	9615.38	8	32	-1.36	9469.70
12500		8	19	0.00	12500.00	1	199	0.00	12500.00
14400		1	138	-0.08	14388.49	1	173	-0.22	14367.82
19200		1	103	0.16	19230.77	1	129	0.16	19230.77
28800		1	68	0.64	28985.51	1	86	-0.22	28735.63
31250		1	63	0.00	31250.00	1	79	0.00	31250.00
38400		1	51	0.16	38461.54	1	64	0.16	38461.54
57600		1	34	-0.79	57142.86	1	42	0.94	58139.53
62500		1	31	0.00	62500.00	1	39	0.00	62500.00
115200		1	16	2.12	117647.06	1	21	-1.36	113636.36
125000		1	15	0.00	125000.00	1	19	0.00	125000.00
250000		1	7	0.00	250000.00	1	9	0.00	250000.00
500000		1	3	0.00	500000.00	1	4	0.00	500000.00
625000		-	-	-	-	1	3	0.00	625000.00
1000000		1	1	0.00	1000000.00	-	-	-	-
1250000		-	-	-	-	1	1	0.00	1250000.00
2000000		1	0	0.00	2000000.00	-	-	-	-
2500000		-	-	-	-	1	0	0.00	2500000.00

Notes: • This does not mean that the communication at the above baud rates is guaranteed. Careful consideration and inspection under your environment are required before use.

- Select clock divider count source in SELCLK bit of SIO special mode register (SnSMOD).
- Select divide-by value of clock divider in the CDIV bit of SIO transmit control register (SnTCNT).
- Set BRG set value in the SIO baud rate register (SnBAUR).

### 12.2.8 SIO Special Mode Registers

SIO0 Special Mode Register (S0SMOD)	<Address: H'0080 0118>
SIO1 Special Mode Register (S1SMOD)	<Address: H'0080 0128>
SIO2 Special Mode Register (S2SMOD)	<Address: H'0080 0138>
SIO3 Special Mode Register (S3SMOD)	<Address: H'0080 0148>
SIO4 Special Mode Register (S4SMOD)	<Address: H'0080 0A18>
SIO5 Special Mode Register (S5SMOD)	<Address: H'0080 0A28>

b0	1	2	3	4	5	6	b7
CSIBL				SELCLK	SELFST	SEL3PNT	CKPOL
0	0	0	0	0	0	0	0

<Upon exiting reset: H'00>

b	Bit Name	Function	R	W
0–3	CSIBL CSIO bit length select bit	0000: 8 bits 0001: 9 bits 0010: 10 bits 0011: 11 bits 0100: 12 bits 0101: 13 bits 0110: 14 bits 0111: 15 bits 1xxx: 16 bits	R	W
4	SELCLK Clock divider count source select bit	0: f(BCLK)/2 1: f(BCLK)	R	W
5	SELFST Transfer order select bit	0: LSB-first 1: MSB-first	R	W
6	SEL3PNT 3-point sampling control bit	0: 3-point sampling invalid 1: 3-point sampling valid	R	W
7	CKPOL Transmit/receive clock polarity select bit	0: Transmit data output at SCLK falling edge Receive data fetch at SCLK rising edge 1: Transmit data output at SCLK rising edge Receive data fetch at SCLK falling edge	R	W

#### (1) CSIBL (CSIO Bit Length Select) bits (Bits 0–3)

These bits are effective only when the clock-synchronous serial interface was selected with the transmitting/receiving mode register. They select the data length.

#### (2) SELCLK (Clock Divider Count Source Select) bit (Bit 4)

This bit is provided for selection of clock divider count source.

#### (3) SELFST (Transfer Order Select) bit (Bit 5)

This bit selects the data bit transfer order.

#### (4) SEL3PNT (3 Points Sampling Control) bit (Bit 6)

Setting this bit to “1” allows 3-point sampling of each signal of RxD input/SCLKI input with BCLK period, and SIO operates with its majority output as RxD input/SCLKI input. RxD input and SCLKI input cannot be controlled individually. Also, 3-point sampling for SCLKI becomes effective only at CSIO mode and external clock selection.

#### (5) CKPOL (Transfer/Receive Clock Polarity Select) bit (Bit 7)

This bit is used to select the transmit/receive clock polarity in the CSIO mode.

By setting this bit to "0," a data is output from the TXD pin synchronously with SCLK falling edge, and a data is fetched from the RXD pin synchronously with SCLK rising edge.

By setting this bit to "1," a data is output from the TXD pin synchronously with SCLK rising edge, and a data is fetched from the RXD pin synchronously with SCLK falling edge.

Note: • Change the SIO special mode register value in the inhibiting state for both transmit enable bit and receive enable bit.

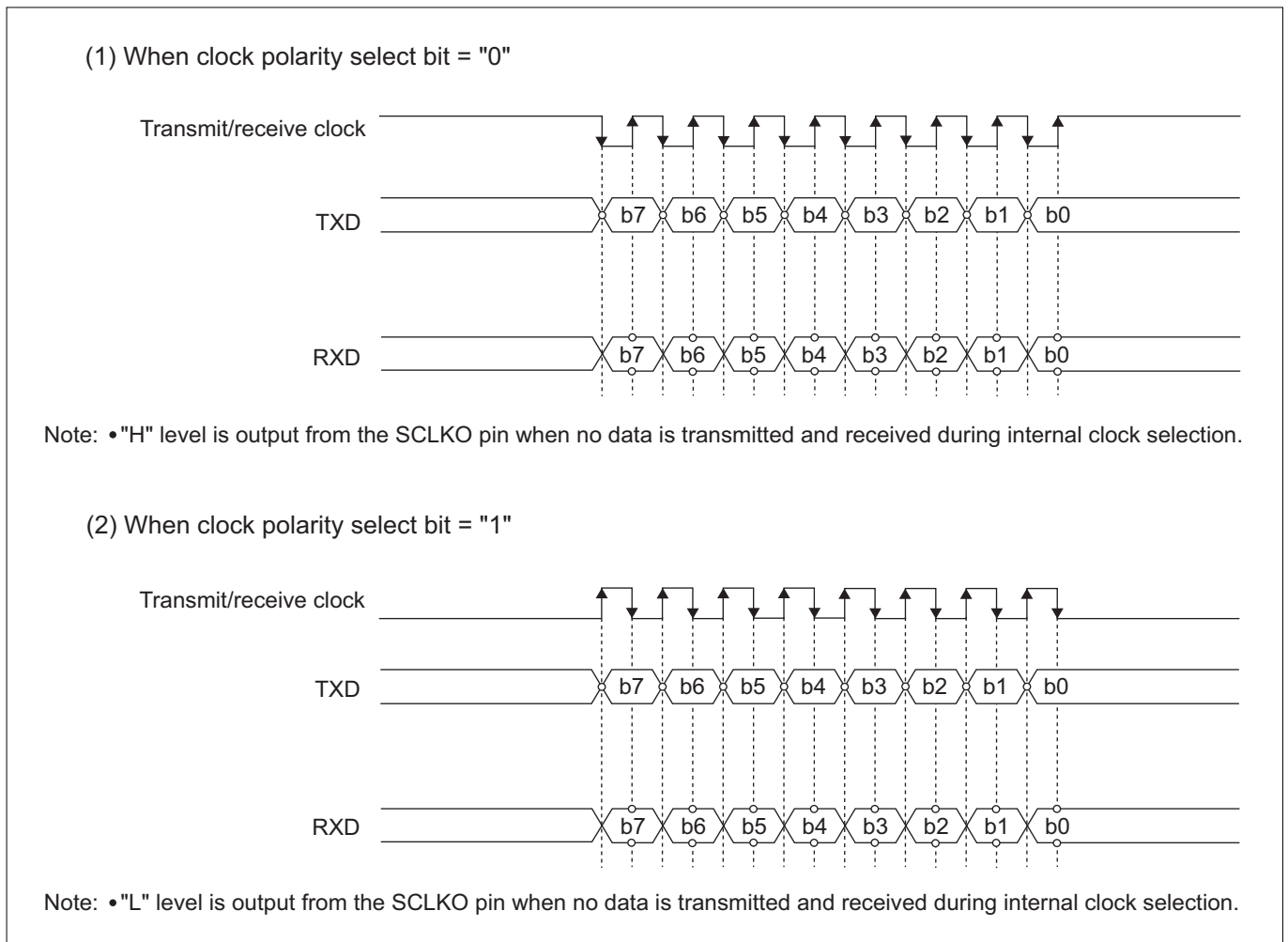


Figure 12.2.9 Selection of Transmit/Receive Clock Polarity



## 12.3 Transmit Operation in CSIO Mode

### 12.3.1 Setting the CSIO Baud Rate

The baud rate (data transfer rate) in CSIO mode is determined by a transmit/receive shift clock. The clock source from which a transmit/receive shift clock derives is selected from the internal clock  $f(\text{BCLK})$  or external clock. The CKS (Internal/External Clock Select) bit (SIO Transmit/Receive Mode Register bit 11) is used to select the clock source.

The equation used to calculate the transmit/receive baud rate differs depending on whether an internal or external clock is selected.

#### (1) When internal clock is selected in CSIO mode

When the internal clock was selected, select the clock source from  $f(\text{BCLK})$  or  $f(\text{BCLK})/2$  with the clock divider count source select bit (bit 4 of SIO special mode register).  $f(\text{BCLK})$  or  $f(\text{BCLK})/2$  is input to the baud rate generator (BRG) after being divided by the clock divider.

The clock divider's divide-by value is selected from 1, 8, 32 or 256 by using the CDIV (baud rate generator count source select) bits (Transmit Control Register bits 2–3).

The Baud Rate Generator divides the clock divider output by (baud rate register set value + 1) and further by 2, thus generating a transmit/receive shift clock.

When the internal clock is selected in CSIO mode, the baud rate is calculated using the equation below.

$$\text{Baud rate [bps]} = \frac{f(\text{BCLK}) \text{ or } f(\text{BCLK})/2}{\text{Clock divider's divide-by value} \times (\text{baud rate register set value} + 1) \times 2}$$

Baud rate register set value = H'00 to H'FF (Note 1)

Clock divider's divide-by value = 1, 8, 32 or 256

Note 1: Use caution when setting the baud rate register so that the transfer rate will not exceed  $f(\text{BCLK})/8$ .

#### (2) When external clock is selected in CSIO mode

In this case, the Baud Rate Generator is not used, and the input clock from the SCLKI pin serves directly as a transmit/receive shift clock for CSIO.

The maximum frequency of the SCLKI pin input clock is  $f(\text{BCLK})/16$ .

$$\text{Baud rate [bps]} = \text{SCLKI pin input clock}$$

### 12.3.2 Initializing CSIO Transmission

To transmit data in CSIO mode, initialize the serial interface following the procedure described below.

#### (1) Setting SIO Special Mode Register

- Set the data length selection in CSIO mode
- Select the clock divider count source
- Set the data bit transfer order
- 3-point sampling control
- Select the clock polarity in CSIO mode

#### (2) Setting SIO Transmit/Receive Mode Register

- Set the register to CSIO mode.
- Select the internal or an external clock.

#### (3) Setting SIO Transmit Control Register

- Select the clock divider's divide-by ratio (when internal clock selected).

#### (4) Setting SIO Baud Rate Register

When the internal clock is selected, set a baud rate generator value. (See Section 12.3.1, "Setting the CSIO Baud Rate.")

#### (5) Setting the SIO interrupt related registers

- Select the source of transmit interrupt request (transmit buffer empty or transmission finished) (SIO Interrupt Request Source Select Register).
- Enable or disable transmit interrupt requests (SIO Interrupt Request Mask Register).

Note: • Transmission finished interrupt requests are effective only when the internal clock is selected.

#### (6) Setting the Interrupt Controller (SIO Transmit Interrupt Control Register)

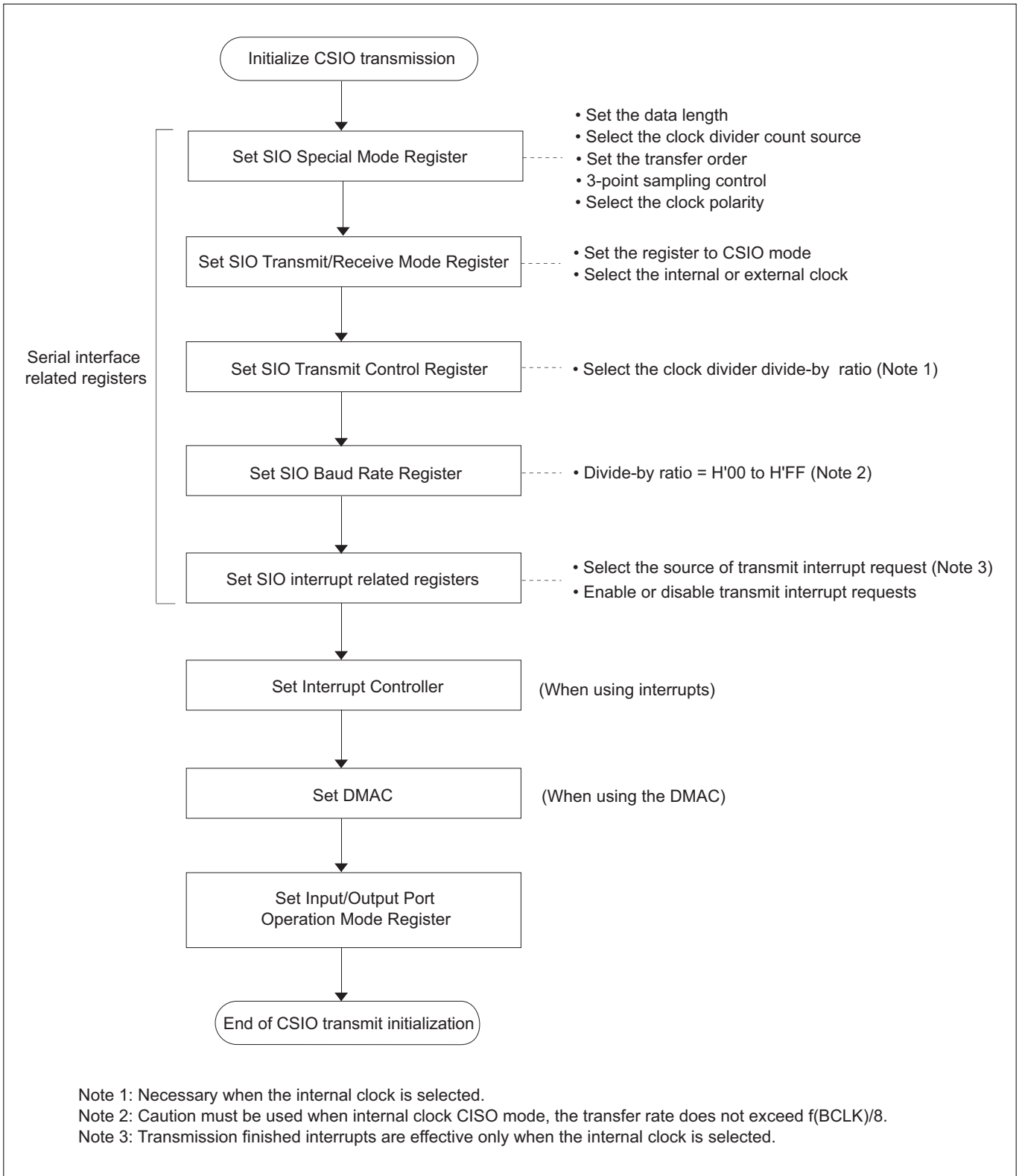
To use transmit interrupts, set their priority levels.

#### (7) Setting the DMAC

To issue DMA transfer requests to the internal DMAC when the transmit buffer is empty, set up the DMAC. (See Chapter 9, "DMAC.")

#### (8) Selecting pin functions

Because the serial interface related pins serve dual purposes, set the pin functions for use as SIO pins or input/output ports. (See Chapter 8, "Input/Output Ports and Pin Functions.")



**Figure 12.3.1 Procedure for Initializing CSIO Transmission**

### 12.3.3 Starting CSIO Transmission

The serial interface starts a transmit operation when all of the following conditions are met after being initialized.

#### (1) Transmit conditions when CSIO mode internal clock is selected

- The SIO Transmit Control Register transmit enable bit is set to "1."
- Transmit data (8–16 bits) is written to the lower byte of the SIO Transmit Buffer Register (transmit buffer empty bit = "0") (Note 1) (Note 2)

#### (2) Transmit conditions when CSIO mode external clock is selected

- The SIO Transmit Control Register transmit enable bit is set to "1."
- Transmit data is written to the lower byte of the SIO Transmit Buffer Register (transmit buffer empty bit = "0"). (Note 1)
- A transmit clock (clock polarity is selected by CKPOL bit of the SnSMOD register) is inputted to the SCLKI pin.

When transmission starts, the serial interface sends data following the procedure described below.

- Transfer the content of the SIO Transmit Buffer Register to the SIO Transmit Shift Register.
- Set the transmit buffer empty bit to "1" (Note 3).
- Start sending data synchronously with the shift clock.

Note 1: While the transmit enable bit is cleared to "0," writes to the Transmit Buffer Register are ignored. Always set the transmit enable bit to "1" before writing to the Transmit Buffer Register. Also, the transmit status bit is set to "1" at the time data is set in the lower byte of the SIO Transmit Buffer Register.

Note 2: When the internal clock is selected, a write to the lower byte of the Transmit Buffer Register triggers transmission to start.

Note 3: A transmit interrupt request can be generated for reasons that the transmit buffer is empty or transmission has finished. Also, a DMA transfer request can be generated when the transmit buffer is empty. No DMA transfer requests can be generated for reasons that transmission has finished.

### 12.3.4 Successive CSIO Transmission

Once data has been transferred from the transmit buffer register to the transmit shift register, the next data can be written to the transmit buffer register even when the serial interface has not finished sending the previous data. If the next data is written to the transmit buffer register before transmission has finished, the previous and the next data are transmitted successively.

Check the SIO Transmit Control Register's Status Register's transmit buffer empty flag to see if data has been transferred from the transmit buffer register to the transmit shift register.

### 12.3.5 Processing at End of CSIO Transmission

When data transmission finishes, the following operation is automatically performed in hardware.

#### (1) When not transmitting successively

- The transmit status bit is cleared to "0."

#### (2) When transmitting successively

- When transmission of the last data in a consecutive data train finishes, the transmit status bit is cleared to "0."

### 12.3.6 Transmit Interrupts

#### (1) Transmit buffer empty interrupt

If the transmit buffer empty interrupt was selected using the SIO Interrupt Request Source Select Register, a transmit buffer empty interrupt request is generated when data has been transferred from the transmit buffer register to the transmit shift register. A transmit buffer empty interrupt request is also generated when the TEN (Transmit Enable) bit is set to "1" (disabled → enabled) while the transmit buffer empty interrupt has been enabled.

#### (2) Transmission finished interrupt

If the transmission finished interrupt was selected using the SIO Interrupt Request Source Select Register, a transmission finished interrupt request is generated by a falling edge of the internal transfer clock pulse at which the last bit of data in the transmit shift register has been transmitted.

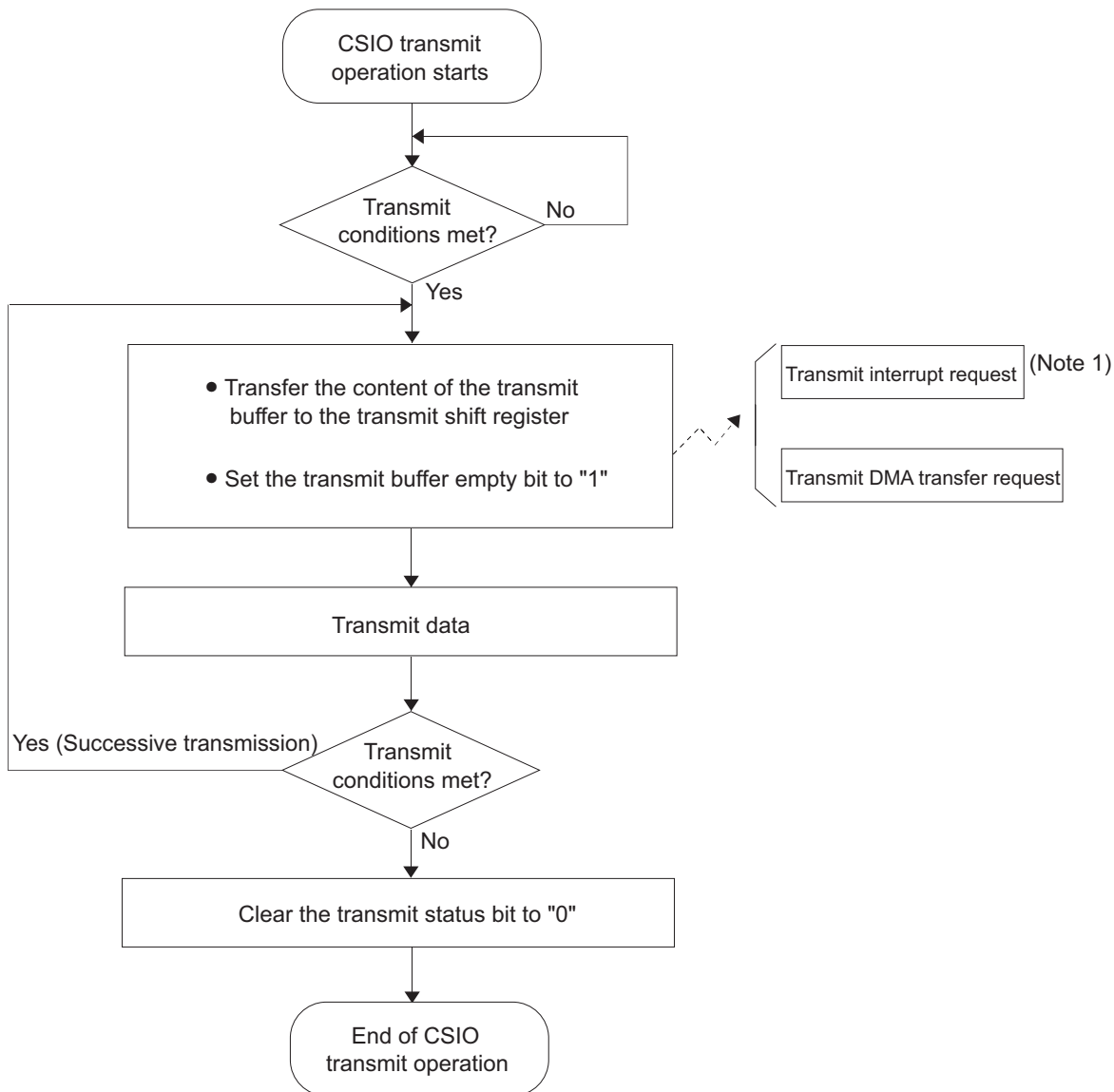
The SIO Interrupt Request Mask Register and the Interrupt Controller (ICU) must be set before these transmit interrupts can be used.

### 12.3.7 Transmit DMA Transfer Request

When data has been transferred from the transmit buffer register to the transmit shift register, a transmit DMA transfer request for the corresponding SIO channel is output to the DMAC. A transmit DMA transfer request is also output when the TEN (Transmit Enable) bit is set to "1" (disabled → enabled).

The DMAC must be set before DMA transfers can be used during data transmission.

The following processing is automatically performed in hardware.



Note 1: This applies when the transmit interrupt request was enabled using the SIO Interrupt Request Mask Register after selecting the transmit buffer empty interrupt with the SIO Interrupt Request Source Select Register.

Figure 12.3.2 Transmit Operation during CSIO Mode (Hardware Processing)

#### 12.3.8 Example of CSIO Transmit Operation

The following shows a typical transmit operation in CSIO mode.

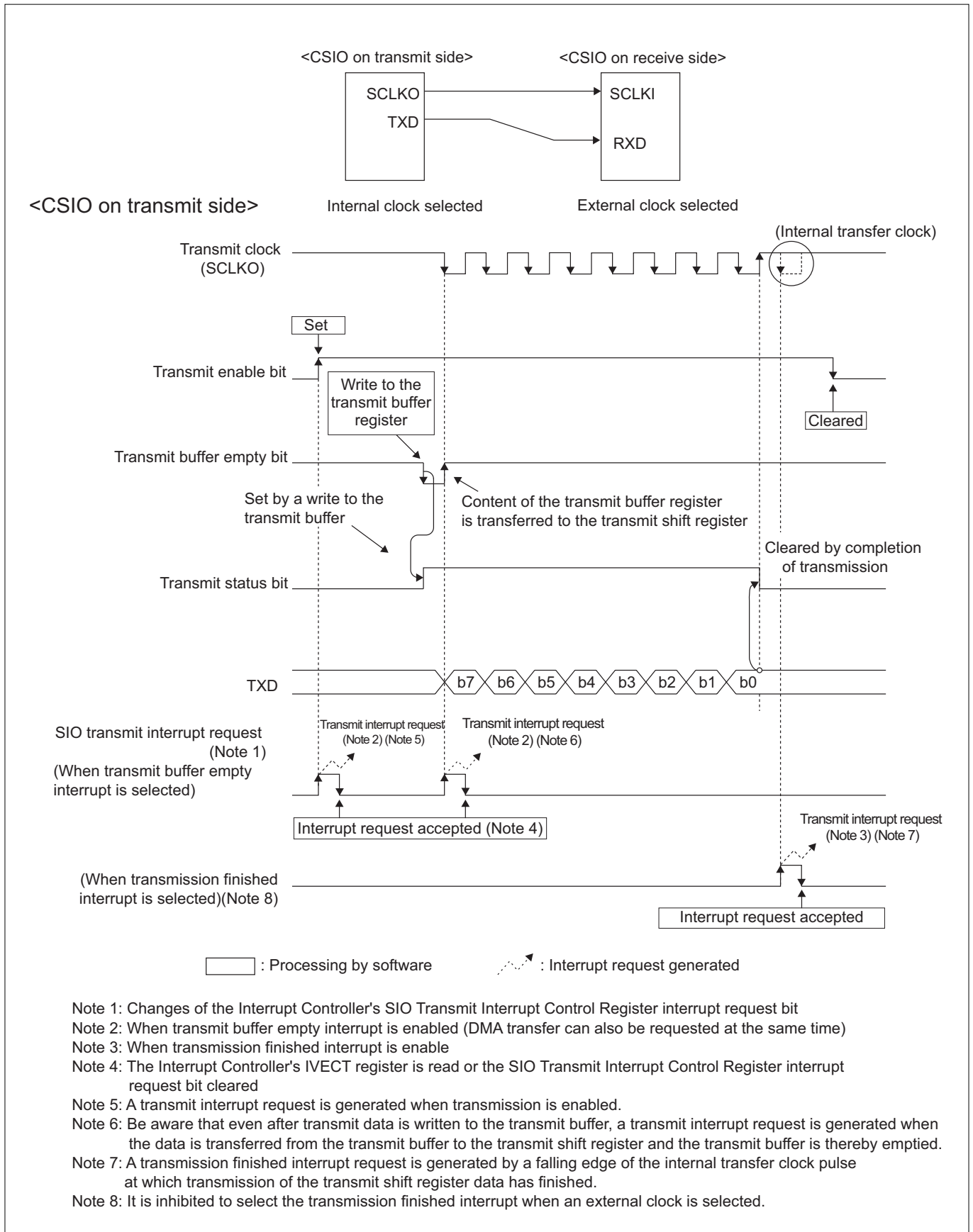
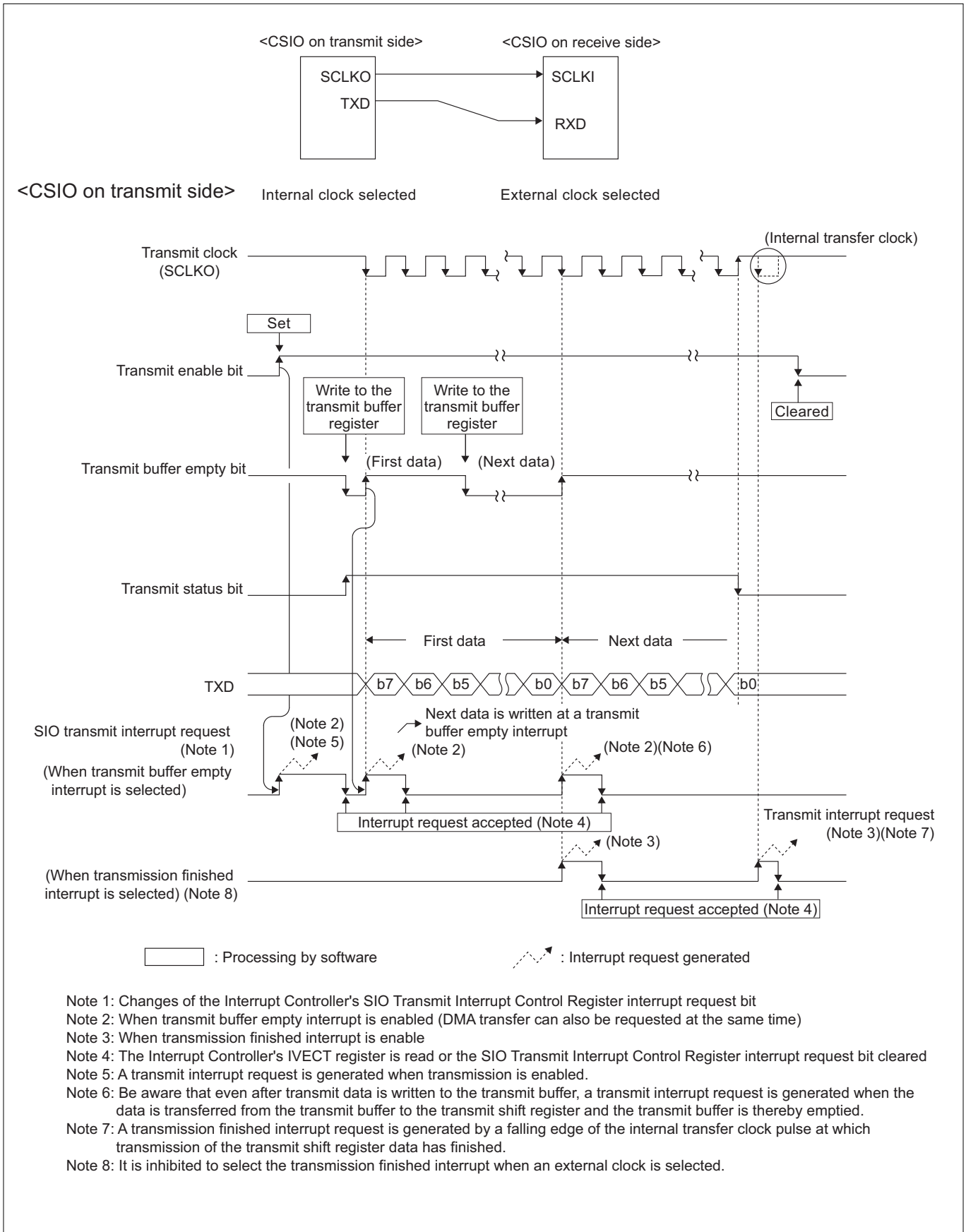


Figure 12.3.3 Example of CSIO Transmission (Transmitted Only Once)



**Figure 12.3.4 Example of CSIO Transmission (Transmitted Successively)**



## 12.4 Receive Operation in CSIO Mode

### 12.4.1 Initialization for CSIO Reception

To receive data in CSIO mode, initialize the serial interface following the procedure described below. Note, however, that because the receive shift clock is derived by an operation of the transmit circuit, transmit operation must always be executed even when the serial interface is used for only receiving data.

#### (1) Setting SIO Special Mode Register

- Set the data length selection in CSIO mode
- Select the clock divider count source
- Set the data bit transfer order
- 3-point sampling control
- Select the clock polarity in CSIO mode

#### (2) Setting SIO Transmit/Receive Mode Register

- Set the register to CSIO mode.
- Select the internal or an external clock.

#### (3) Setting SIO Transmit Control Register

- Select the clock divider's divide-by ratio (when internal clock selected).

#### (4) Setting SIO Baud Rate Register

When the internal clock is selected, set a baud rate generator value. (See Section 12.3.1, "Setting the CSIO Baud Rate.")

#### (5) Setting SIO interrupt related registers

- Select the source of receive interrupt request (reception finished or error) (SIO Interrupt Request Source Select Register).
- Enable or disable receive interrupts (SIO Interrupt Request Mask Register).

#### (6) Setting SIO Receive Control Register

- Set the receive enable bit.

#### (7) Setting Interrupt Controller (SIO Receive Interrupt Control Register)

To use receive interrupts, set their priority levels.

#### (8) Setting DMAC

Set up the DMAC when the DMA transfer is requested to the internal DMAC on completion of the reception. (See Chapter 9, "DMAC.")

#### (9) Selecting pin functions

Because the serial interface related pins serve dual purposes, set the pin functions for use as SIO pins or input/output ports. (See Chapter 8, "Input/Output Ports and Pin Functions.")

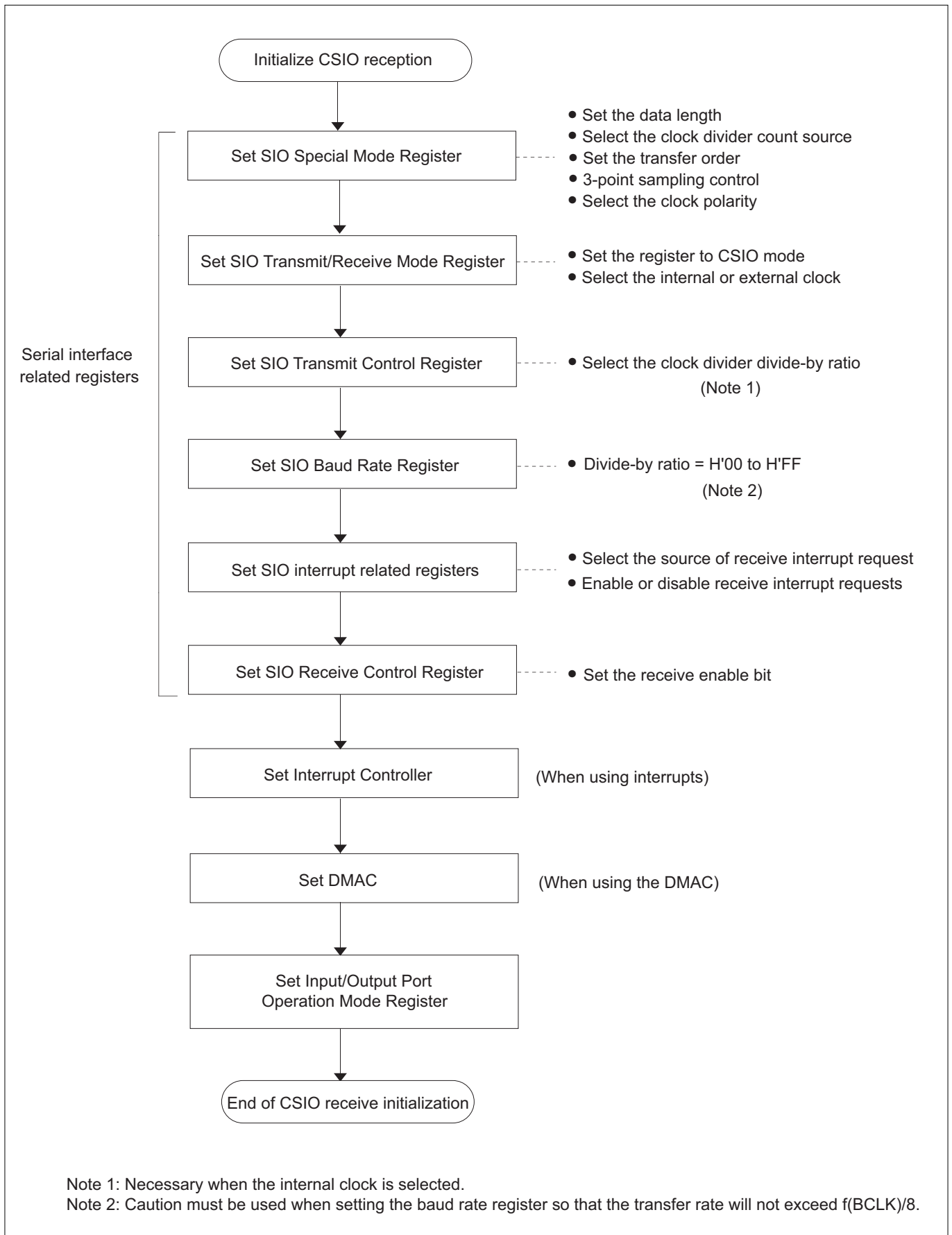


Figure 12.4.1 Procedure for Initializing CSIO Reception

### 12.4.2 Starting CSIO Reception

The serial interface starts receive operation when all of the following conditions are met after being initialized.

#### (1) Receive conditions when CSIO mode internal clock is selected

- The SIO Receive Control Register receive enable bit is set to "1."
- Transmit conditions are met. (See Section 12.3.3, "Starting CSIO Transmission.")

#### (2) Receive conditions when CSIO mode external clock is selected

- The SIO Receive Control Register receive enable bit is set to "1."
- Transmit conditions are met. (See Section 12.3.3, "Starting CSIO Transmission.")

Note: • The receive status bit is set to "1" at the time dummy data is set in the lower byte of the SIO Transmit Buffer Register.

When the above conditions are met, the serial interface starts receiving 8 to 16 bits serial data synchronously with the receive shift clock.

### 12.4.3 Processing at End of CSIO Reception

When data reception finishes, the following operation is automatically performed in hardware.

#### (1) When reception is completed normally

The reception finished (receive buffer full) bit is set to "1."

- Notes:
- An interrupt request is generated if the reception finished (receive buffer full) interrupt has been enabled.
  - A DMA transfer request is generated.

#### (2) When an error occurred during reception

If an error (only overrun error in CSIO mode) occurred during reception, the overrun error bit and receive error sum bit are set to "1."

- Notes:
- If the reception finished interrupt has been selected (by SIO Receive Interrupt Request Source Select Register), neither a reception finished interrupt request nor a DMA transfer request is generated.
  - If the receive error interrupt has been selected (by SIO Receive Interrupt Request Source Select Register), a receive error interrupt request is generated when interrupt requests are enabled. No DMA transfer requests are generated.

#### 12.4.4 About Successive Reception

If the following conditions are met when data reception has finished, data may be received successively.

- The receive enable bit is set to "1."
- Transmit conditions are met.
- No overrun error has occurred.

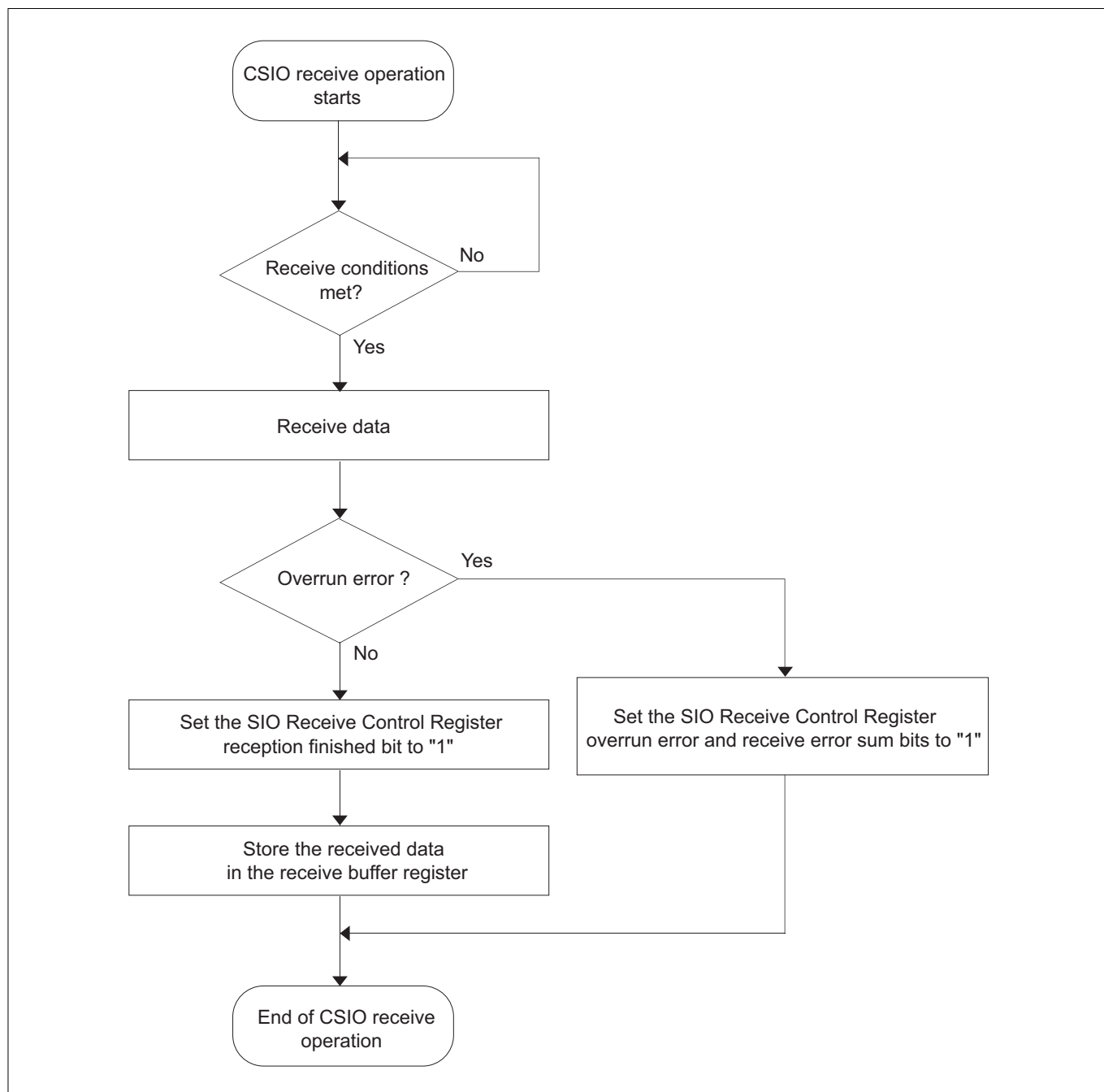


Figure 12.4.2 Receive Operation during CSIO Mode (Hardware Processing)

### 12.4.5 Flags Showing the Status of CSIO Receive Operation

There are following flags that indicate the status of receive operation during CSIO mode:

- SIO Receive Control Register receive status bit
- SIO Receive Control Register reception finished bit
- SIO Receive Control Register receive error sum bit
- SIO Receive Control Register overrun error bit

When reading the content of the SIO Receive Buffer Register after reception is completed, if the serial interface finishes receiving the next data before the previous data is not read out, an overrun error occurs and the subsequent received data are not transferred to the receive buffer register.

Before receive operation can be restarted, the receive enable bit must temporarily be cleared to "0" to initialize the receive control unit.

The above reception finished bit, if no receive errors occurred (Note 1), may be cleared by reading out the lower byte of the SIO Receive Buffer Register or clearing the REN (Receive Enable) bit.

However, if any receive error occurred, the reception finished bit can only be cleared by clearing the REN (Receive Enable) bit, and cannot be cleared by reading out the lower byte of the SIO Receive Buffer Register.

Note 1: Overrun errors are the only error that can be detected during reception in CSIO mode.

### 12.4.6 Example of CSIO Receive Operation

The following shows a typical receive operation in CSIO mode.

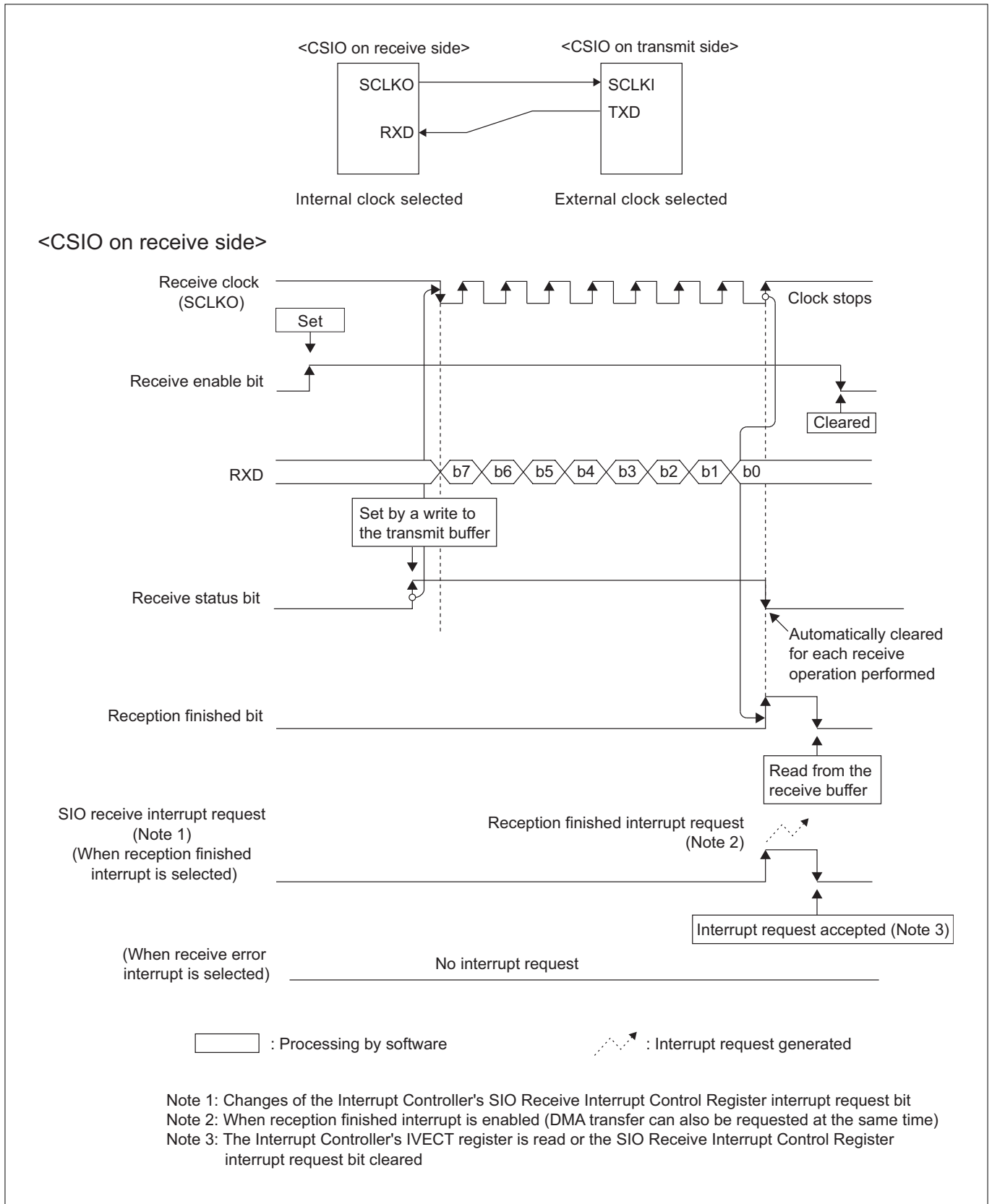


Figure 12.4.3 Example of CSIO Reception (When Received Normally)

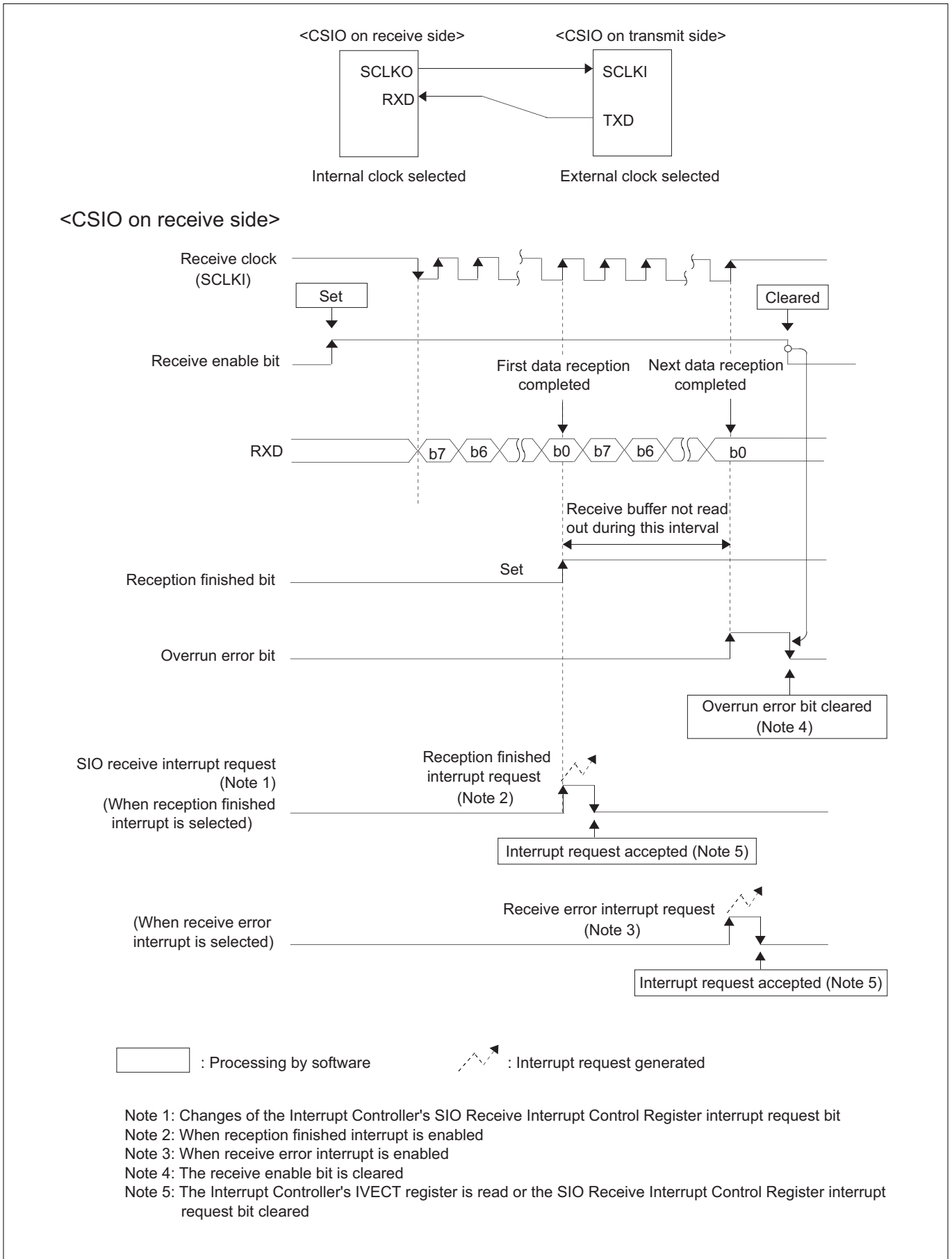


Figure 12.4.4 Example of CSIO Reception (When Overrun Error Occurred)

## 12.5 Notes on Using CSIO Mode

- **Settings of SIO Transmit/Receive Mode Register and SIO Baud Rate Register**

The SIO Transmit/Receive Mode Register, SIO Special Mode Register and SIO Baud Rate Register and the Transmit Control Register's BRG count source select bit must always be set when the serial interface is not operating. If a transmit or receive operation is in progress, wait until the transmit and receive operations are finished and then clear the transmit and receive enable bits before making changes.

- **Settings of SIO Baud Rate Register**

Use caution when setting SIO Baud Rate Register so that the transfer rate will not exceed  $f(\text{BCLK})/8$ .

- **About successive transmission**

To transmit data successively, make sure the next transmit data is set in the SIO Transmit Buffer Register before the current data transmission finishes.

- **About reception**

Because the receive shift clock in CSIO mode is derived by an operation of the transmit circuit, transmit operation must always be executed (by sending dummy data) even when the serial interface is used for only receiving data. In this case, be aware that if the port function is set for the TXD pin (by setting the operation mode register to "1"), dummy data may actually be output from the pin.

- **About successive reception**

To receive data successively, make sure that data (dummy data) is set in the SIO Transmit Buffer Register before a transmit operation on the transmitter side starts.

- **Transmission/reception using DMA**

To transmit/receive data in DMA request mode, enable the DMAC to accept transfer requests (by setting the DMA Mode Register) before serial communication starts.

- **About reception finished bit**

If a receive error (overflow error) occurs, the reception finished bit can only be cleared by clearing the receive enable bit, and cannot be cleared by reading out the receive buffer register.

- **About overrun error**

If all bits of the next received data have been set in the SIO Receive Shift Register before reading out the SIO Receive Buffer Register (i.e., an overrun error occurred), the received data is not stored in the receive buffer register, with the previous received data retained in it. Although a receive operation continues thereafter, the subsequent received data is not stored in the receive buffer register (receive status bit = "1").

Before normal receive operation can be restarted, the receive enable bit must be temporarily cleared to "0." And this is the only way that the overrun error flag can be cleared.

- **About DMA transfer request generation during SIO transmission**

If the transmit buffer register becomes empty (transmit buffer empty flag = "1") while the transmit enable bit remains set to "1" (transmission enabled), an SIO transmit buffer empty DMA transfer request is generated.

- **About DMA transfer request generation during SIO reception**

If the reception finished bit is set to "1" (receive buffer register full), a reception finished DMA transfer request is generated. Be aware, however, that if an overrun error occurred during reception, this DMA transfer request is not generated.



- **Switching from general-purpose to serial interface pin**

When switching general-purpose to serial interface pin, SCLKOn pin outputs "H" level (For the case of selecting internal clock and setting CKPOL bit to "0." When setting CKPOL bit to "1," it outputs "L" level.), and TXDn pin outputs undefined value. However, when switching general-purpose to serial interface pin with setting TEN bit of the SIOOn transmit control register to "1" (transmit enable), TXDn pin outputs the last bit level of the previously output serial data.

## 12.6 Transmit Operation in UART Mode

### 12.6.1 Setting the UART Baud Rate

The baud rate (data transfer rate) in UART mode is determined by a transmit/receive shift clock. During UART mode, the source for this transmit/receive shift clock is always the internal clock no matter how the internal/external clock select bit (SIO Transmit/Receive Mode Register bit 11) is set.

#### (1) Calculating the UART mode baud rate

The clock source is selected from  $f(\text{BCLK})$  or  $f(\text{BCLK})/2$  with the clock divider count source select bit (bit 4 of SIO special mode register).  $f(\text{BCLK})$  or  $f(\text{BCLK})/2$  is input to the baud rate generator (BRG) after being divided by the clock divider, after which it is further divided by 16 to produce a transmit/receive shift clock.

The clock divider's divide-by value is selected from 1, 8, 32 or 256 by using the SIO Transmit Control Register CDIV (baud rate generator count source select) bits (bits 2 and 3).

The Baud Rate Generator divides the clock divider output by (baud rate register set value + 1) and further by 16, thus generating a transmit/receive shift clock.

When the internal clock is selected in UART mode, the baud rate is calculated using the equation below.

$$\text{Baud rate [bps]} = \frac{f(\text{BCLK}) \text{ or } f(\text{BCLK})/2}{\text{Clock divider's divide-by value} \times (\text{baud rate register set value} + 1) \times 16}$$

Baud rate register set value = H'00 to H'FF

Clock divider's divide-by value = 1, 8, 32 or 256

### 12.6.2 UART Transmit/Receive Data Formats

The transmit/receive data format during UART mode is determined by setting the SIO Transmit/Receive Mode Register. Shown below is the transmit/receive data format that can be used in UART mode.

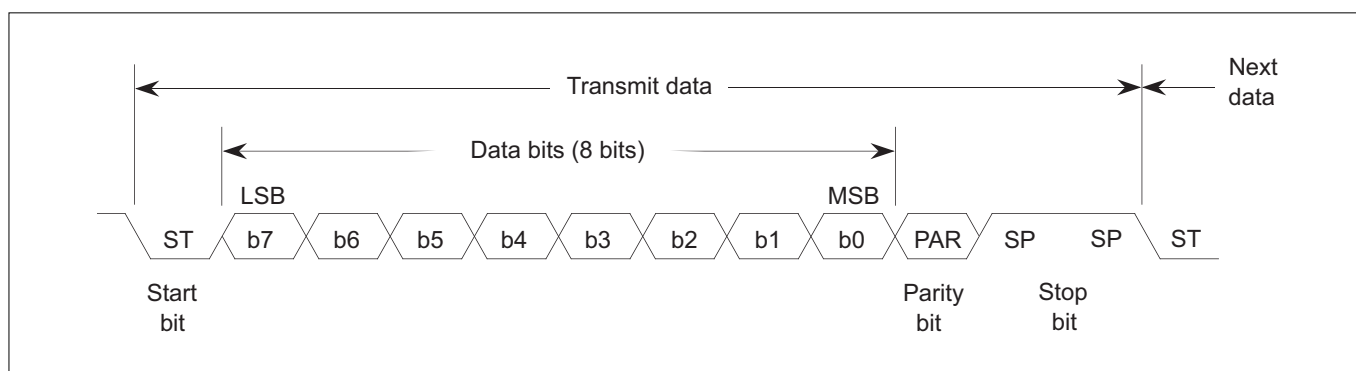
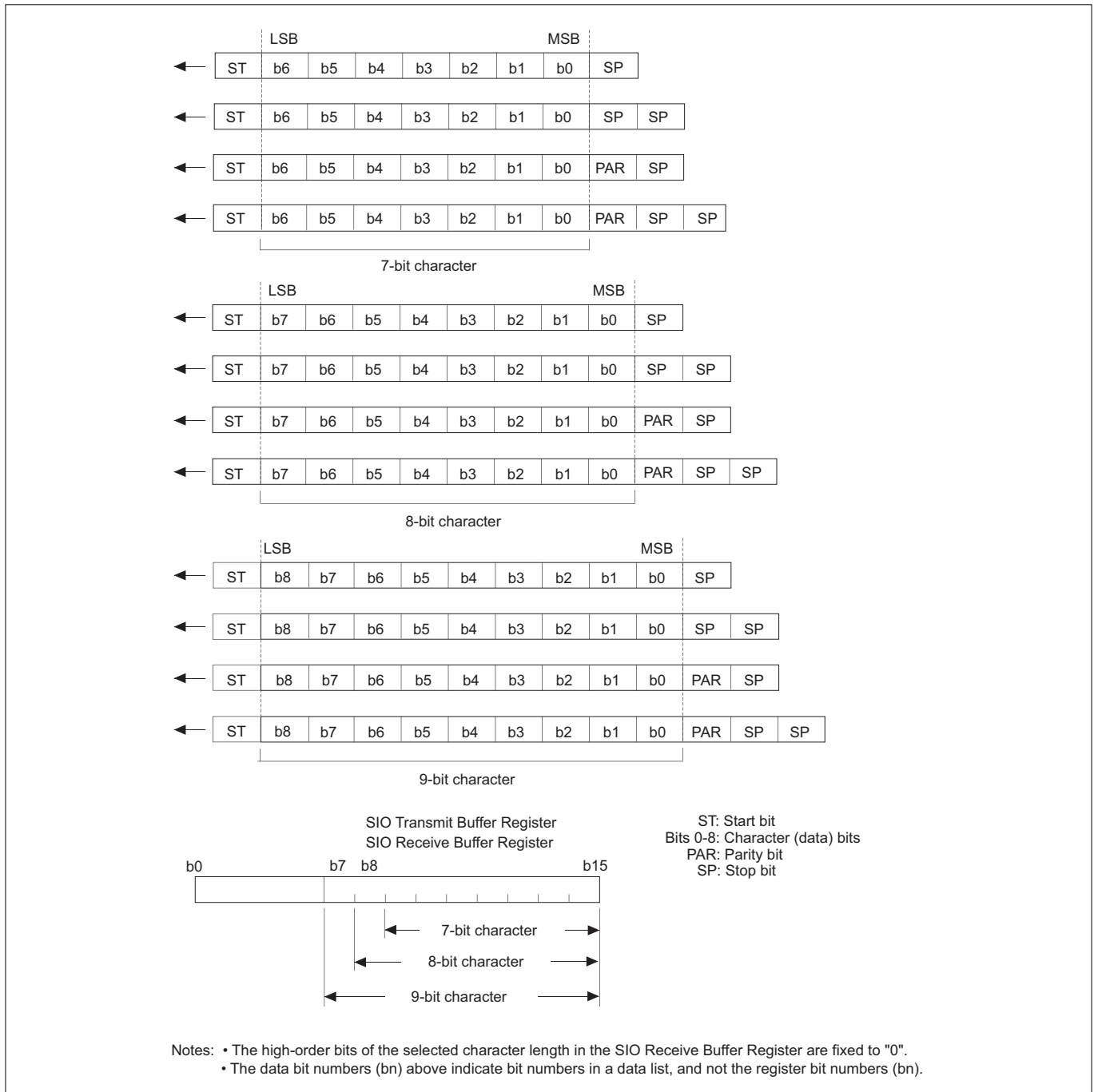


Figure 12.6.1 Example of a Transfer Data Format during UART Mode

**Table 12.6.1 Transfer Data in UART Mode**

Bit Name	Content
ST (start bit)	Indicates the beginning of data transmission. This is a "L" level signal of a one bit period, which is added immediately preceding the transmit data.
Bits 0–8 (character bits)	Transmit/receive data transferred via serial interface. In UART mode, 7, 8 or 9 bits of data can be transmitted/received.
PAR (parity bit)	Added to the transmit/receive character. When parity is enabled, parity is automatically set in such a way that the number of 1's in the character including the parity bit itself is always even or odd as selected by the even/odd parity select bit.
SP (stop bit)	Indicates the end of data transmission, which is added immediately following the character (or if parity is enabled, immediately following the parity bit). The stop bit can be chosen to be one bit or two bits long.



**Figure 12.6.2 Selectable Data Formats during UART Mode**

### 12.6.3 Initializing UART Transmission

To transmit data in UART mode, initialize the serial interface following the procedure described below.

#### (1) Setting SIO Special Mode Register

- Select the clock divider count source.
- Set the data bit transfer order.
- 3-points sampling control.

#### (2) Setting SIO Transmit/Receive Mode Register

- Set the register to UART mode.
- Set parity (when enabled, select odd/even).
- Set the stop bit length.
- Set the character length (Note 1).

Note 1: During UART mode, settings of the internal/external clock select bit have no effect (only the internal clock is useful).

#### (3) Setting SIO Transmit Control Register

- Select the clock divider's divide-by ratio.

#### (4) Setting SIO Baud Rate Register

Set a baud rate generator value. (See Section 12.6.1, "Setting the UART Baud Rate.")

#### (5) Setting SIO interrupt related registers

- Select the source of transmit interrupt request (transmit buffer empty or transmission finished) (SIO Interrupt Request Source Select Register).
- Enable or disable SIO transmit interrupt requests (SIO Interrupt Request Mask Register).

#### (6) Setting Interrupt Controller (SIO Transmit Interrupt Control Register)

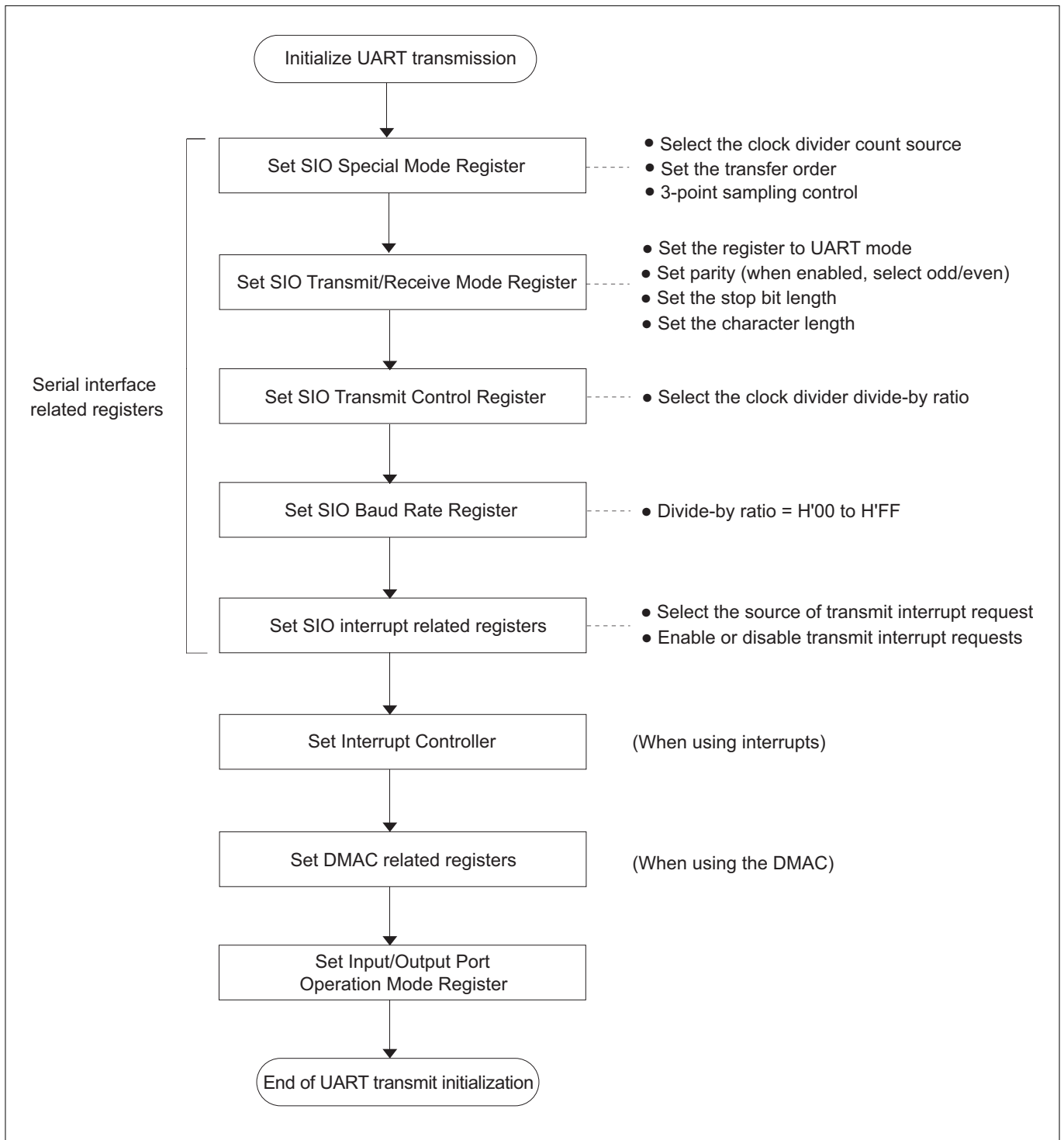
To use transmit interrupts, set their priority levels.

#### (7) Setting DMAC

To issue DMA transfer requests to the internal DMAC when the transmit buffer is empty, set up the DMAC. (See Chapter 9, "DMAC.")

#### (8) Selecting pin functions

Because the serial interface related pins serve dual purposes, set the pin functions for use as SIO pins or input/output ports. (See Chapter 8, "Input/Output Ports and Pin Functions.")



**Figure 12.6.3 Procedure for Initializing UART Transmission**

### 12.6.4 Starting UART Transmission

The serial interface starts a transmit operation when all of the following conditions are met after being initialized.

- SIO Transmit Control Register TEN (Transmit Enable) bit is set to "1" (Note 1).
- Transmit data is written to the SIO Transmit Buffer Register (transmit buffer empty bit = "0").

Note 1: While the transmit enable bit is cleared to "0," writes to the transmit buffer are ignored. Always be sure to set the transmit enable bit to "1" before writing to the transmit buffer register.

When transmission starts, the serial interface sends data following the procedure described below.

- Transfer the content of the SIO Transmit Buffer Register to the SIO Transmit Shift Register.
- Set the transmit buffer empty bit to "1" (Note 2).
- Start sending data synchronously with the shift clock.

Note 2: A transmit interrupt request can be generated for reasons that the transmit buffer is empty or transmission has finished. Also, a DMA transfer request can be generated when the transmit buffer is empty. No DMA transfer requests can be generated for reasons that transmission has finished.

### 12.6.5 Successive UART Transmission

Once data has been transferred from the transmit buffer register to the transmit shift register, the next data can be written to the transmit buffer register even when the serial interface has not finished sending the previous data. If the next data is written to the transmit buffer before transmission has finished, the previous and the next data are transmitted successively.

Check the SIO Transmit Control Register's transmit buffer empty flag to see if data has been transferred from the transmit buffer register to the transmit shift register.

### 12.6.6 Processing at End of UART Transmission

When data transmission finishes, the following operation is automatically performed in hardware.

#### (1) When not transmitting successively

- The transmit status bit is cleared to "0."

#### (2) When transmitting successively

- When transmission of the last data in a consecutive data train finishes, the transmit status bit is cleared to "0."

### 12.6.7 Transmit Interrupts

#### (1) Transmit buffer empty interrupt

If the transmit buffer empty interrupt was selected using the SIO Interrupt Request Source Select Register, a transmit buffer empty interrupt request is generated when data has been transferred from the transmit buffer register to the transmit shift register. A transmit buffer empty interrupt request is also generated when the TEN (Transmit Enable) bit is set to "1" (reenabled after being disabled) while the transmit buffer empty interrupt has been enabled.

#### (2) Transmission finished interrupt

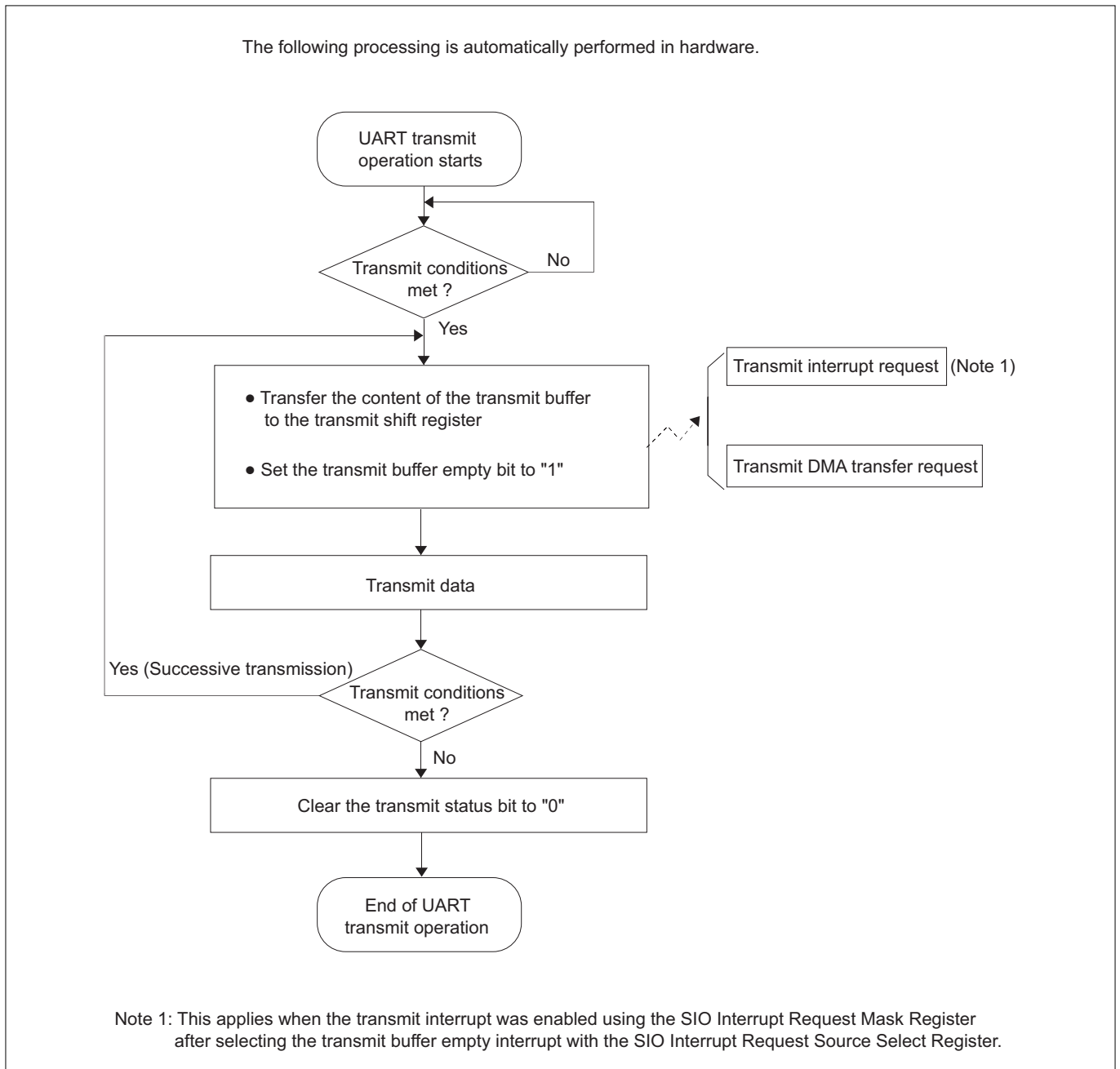
If the transmission finished interrupt was selected using the SIO Interrupt Request Source Select Register, a transmission finished interrupt request is generated when data in the transmit shift register has all been transmitted.

The SIO Interrupt Request Mask Register and the Interrupt Controller (ICU) must be set before these transmit interrupts can be used.

#### 12.6.8 Transmit DMA Transfer Request

When data has been transferred from the transmit buffer register to the transmit shift register, a transmit DMA transfer request for the corresponding SIO channel is output to the DMAC. A transmit DMA transfer request is also output when the TEN (Transmit Enable) bit is set to "1" (disabled → enabled).

The DMAC must be set before DMA transfers can be used during data transmission.



**Figure 12.6.4 Transmit Operation during UART Mode (Hardware Processing)**

#### 12.6.9 Example of UART Transmit Operation

The following shows a typical transmit operation in UART mode.

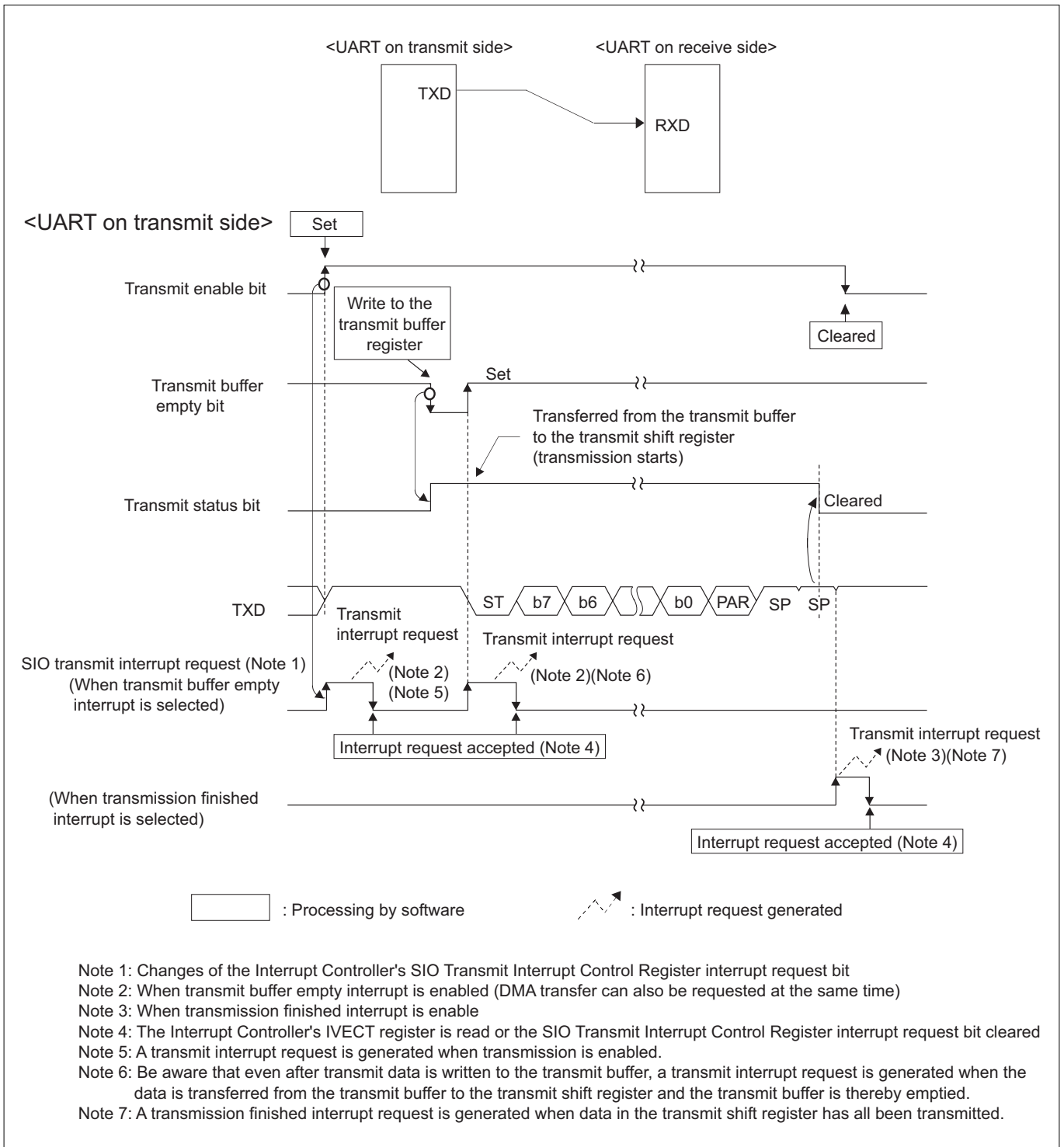
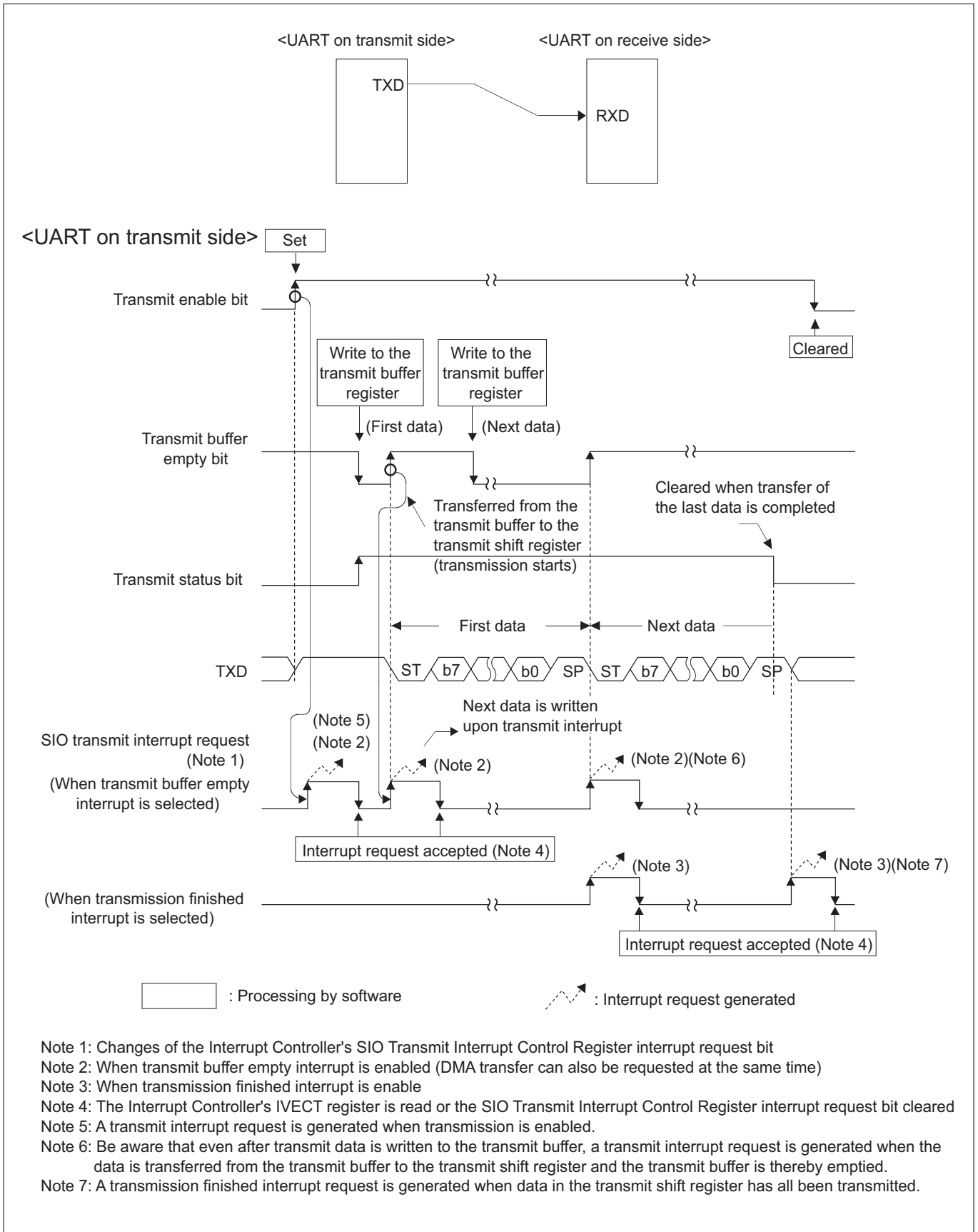


Figure 12.6.5 Example of UART Transmission (Transmitted Only Once)





**Figure 12.6.6 Example of UART Transmission (Transmitted Successively)**

## 12.7 Receive Operation in UART Mode

### 12.7.1 Initialization for UART Reception

To receive data in UART mode, initialize the serial interface following the procedure described below.

#### (1) Setting SIO Special Mode Register

- Select the clock divider count source.
- Set the data bit transfer order.
- 3-points sampling control.

#### (2) Setting SIO Transmit/Receive Mode Register

- Set the register to UART mode.
- Set parity (when enabled, select odd/even).
- Set the stop bit length.
- Set the character length.

Note: • During UART mode, settings of the internal/external clock select bit have no effect (only the internal clock is useful).

#### (3) Setting SIO Transmit Control Register

- Set the clock divider's divide-by ratio.

#### (4) Setting SIO Baud Rate Register

Set a baud rate generator value. (See Section 12.6.1, "Setting the UART Baud Rate.")

#### (5) Setting SIO interrupt related registers

- Select the source of receive interrupt request (reception finished or receive error) (Interrupt Request Source Select Register).
- Enable or disable receive interrupts (SIO Interrupt Request Mask Register).

#### (6) Setting Interrupt Controller

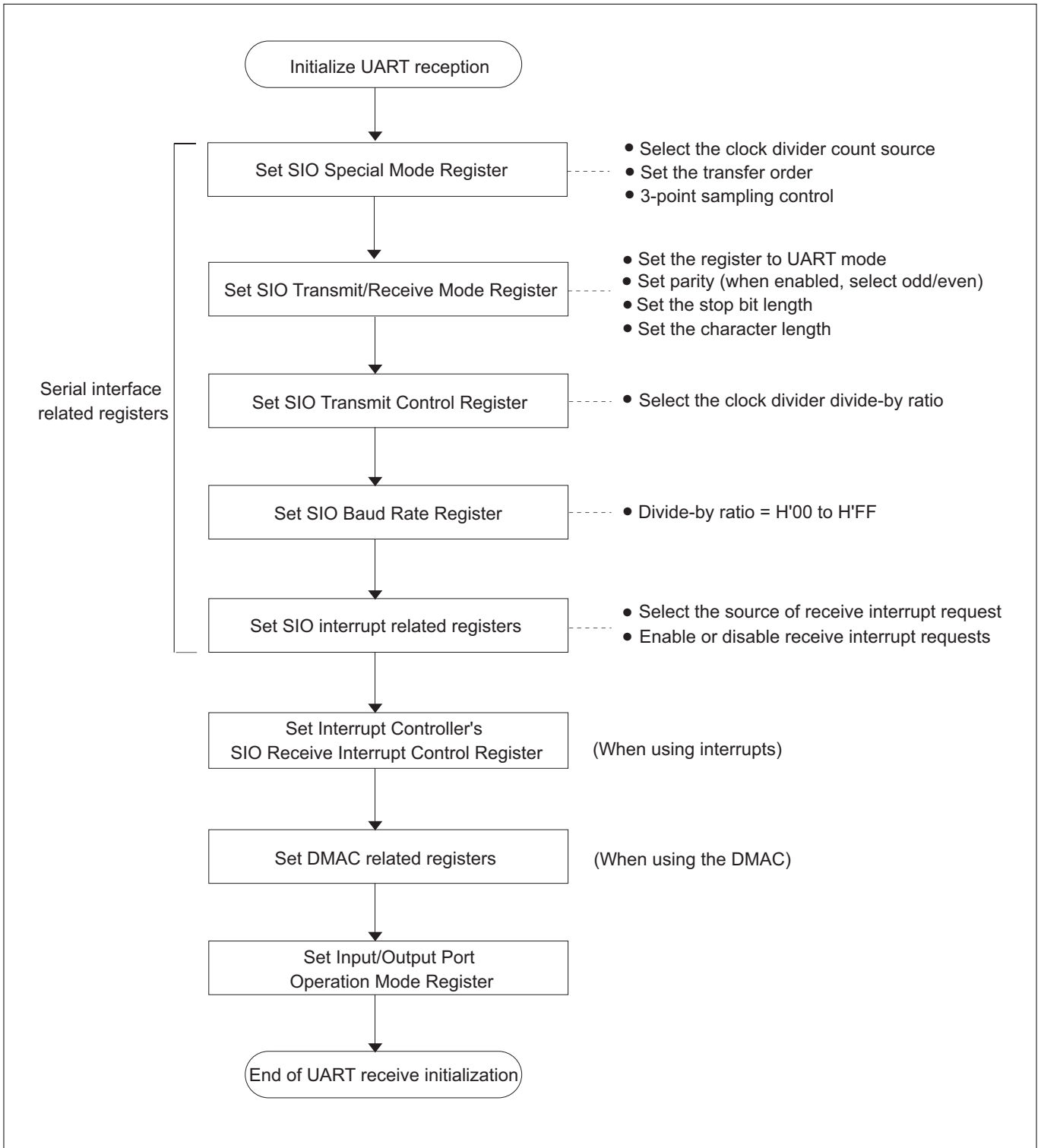
To use reception interrupts, set their priority levels.

#### (7) Setting DMAC

To issue DMA transfer requests to the internal DMAC when reception has finished, set up the DMAC. (See Chapter 9, "DMAC.")

#### (8) Selecting pin functions

Because the serial interface related pins serve dual purposes, set the pin functions for use as SIO pins or input/output ports. (See Chapter 8, "Input/Output Ports and Pin Functions.")



**Figure 12.7.1 Procedure for Initializing UART Reception**

### 12.7.2 Starting UART Reception

The serial interface starts receive operation when all of the following conditions are met after being initialized.

- SIO Receive Control Register receive enable bit is set to "1"
- Start bit (falling edge signal) is applied to the RXD pin

When the above conditions are met, the serial interface enters UART receive operation. However, the start bit is checked again at the first rise of the internal receive shift clock and if it is detected "H" for reasons of noise, etc., the serial interface stops receive operation and waits for the start bit again.

### 12.7.3 Processing at End of UART Reception

When data reception finishes, the following operation is automatically performed in hardware.

#### (1) When reception is completed normally

The reception finished (receive buffer full) bit is set to "1."

- Notes:
- An interrupt request is generated if the reception finished (receive buffer full) interrupt has been enabled.
  - A DMA transfer request is generated.

#### (2) When a receive error occurred

If an error occurred, the corresponding error bit (OE, FE or PE) and the receive error sum bit are set to "1."

- Notes:
- If the reception finished interrupt has been selected (by SIO Receive Interrupt Request Source Select Register), a reception finished interrupt request is generated when interrupt requests are enabled. However, this does not apply when the detected error is an overrun error, in which case no reception finished interrupt requests are generated.
  - If the receive error interrupt has been selected (by SIO Receive Interrupt Request Source Select Register), a receive error interrupt request is generated when interrupt requests are enabled.
  - No DMA transfer requests are generated.

The following processing is automatically performed in hardware.

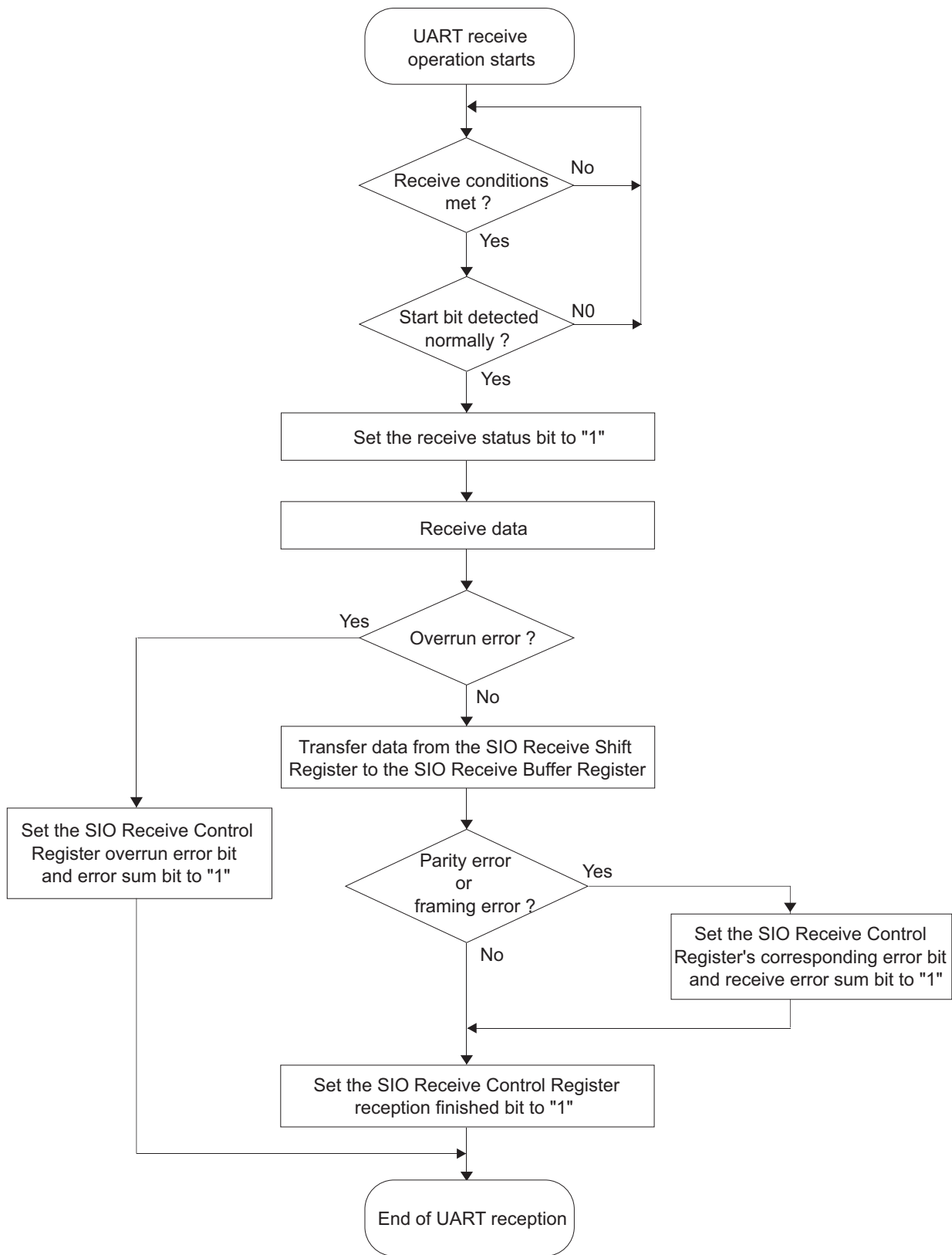


Figure 12.7.2 Receive Operation during UART Mode (Hardware Processing)

#### 12.7.4 Example of UART Receive Operation

The following shows a typical receive operation in UART mode.

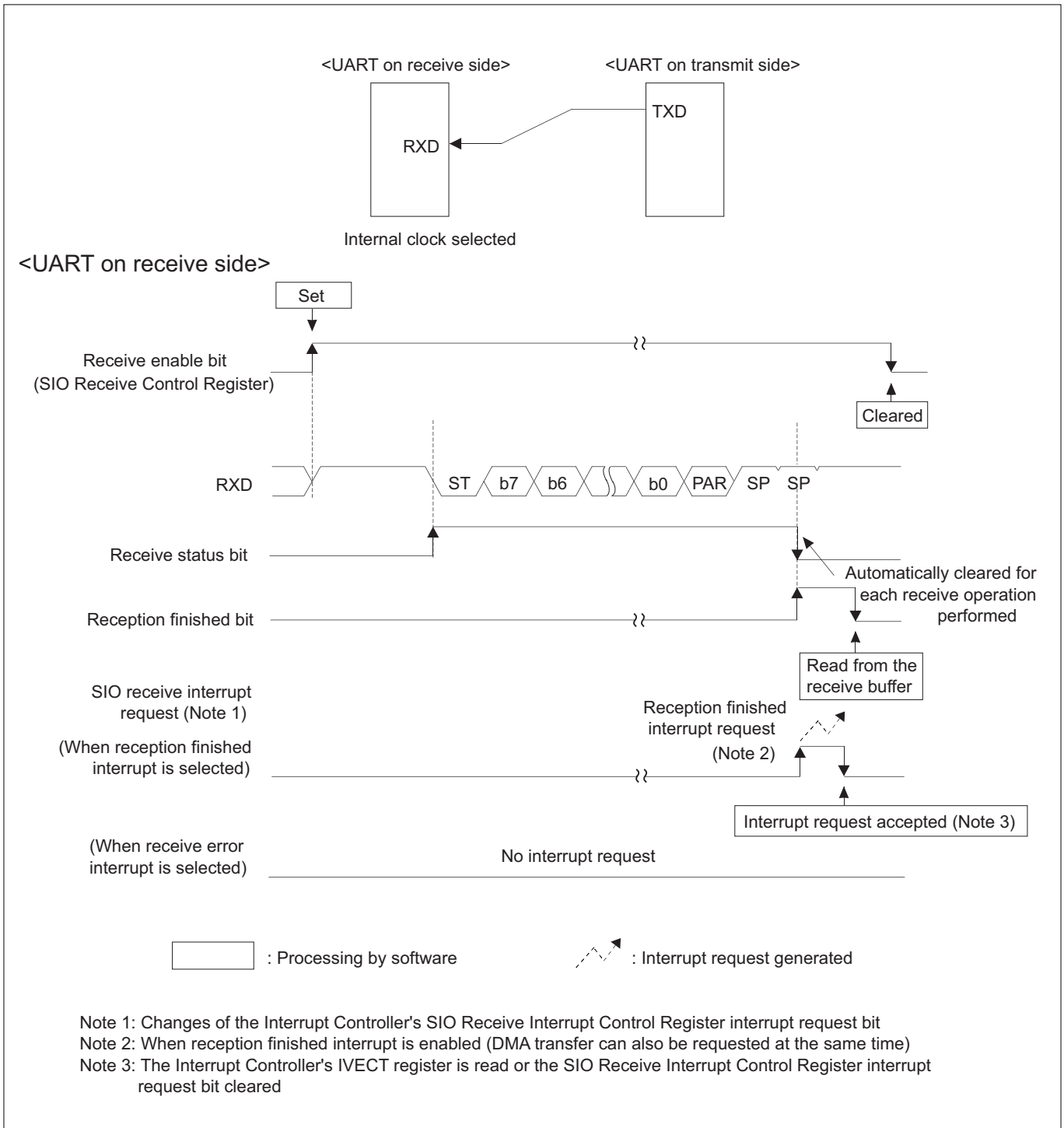


Figure 12.7.3 Example of UART Reception (When Received Normally)

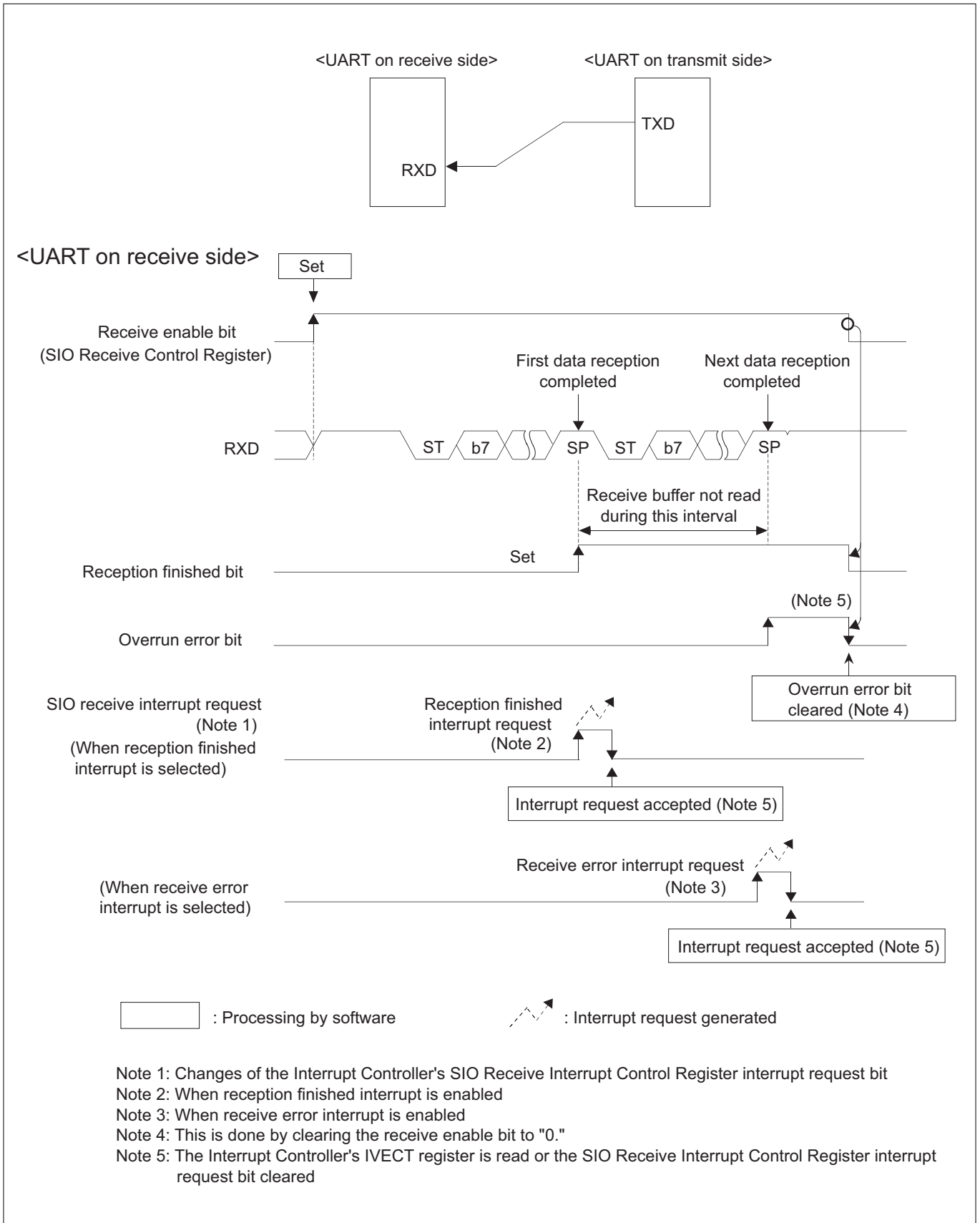
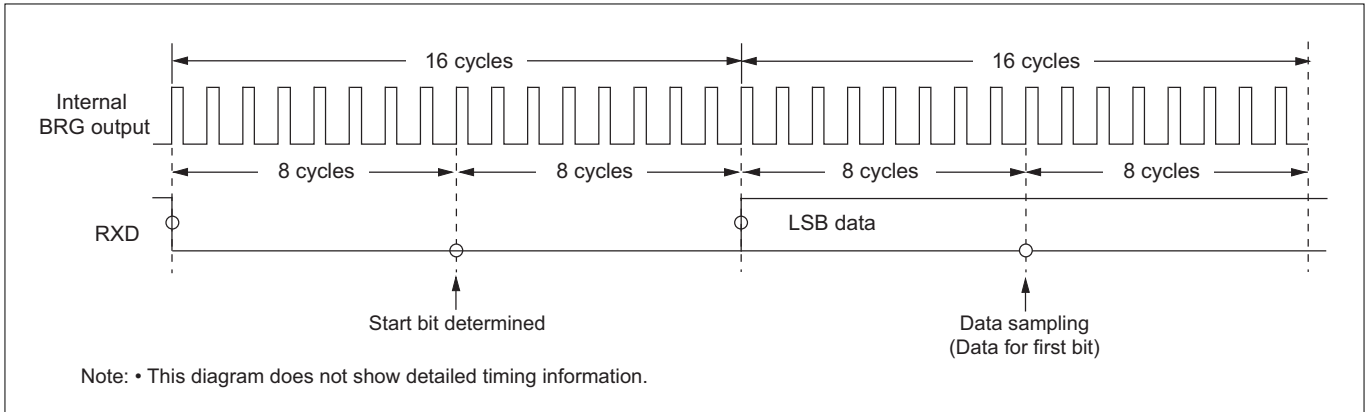


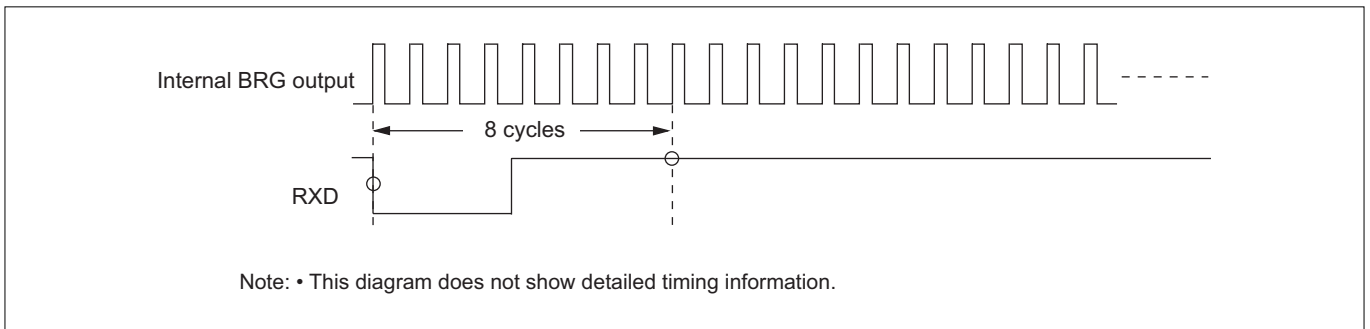
Figure 12.7.4 Example of UART Reception (When Overrun Error Occurred)

#### 12.7.5 Start Bit Detection and Data Sampling Timing during UART Reception

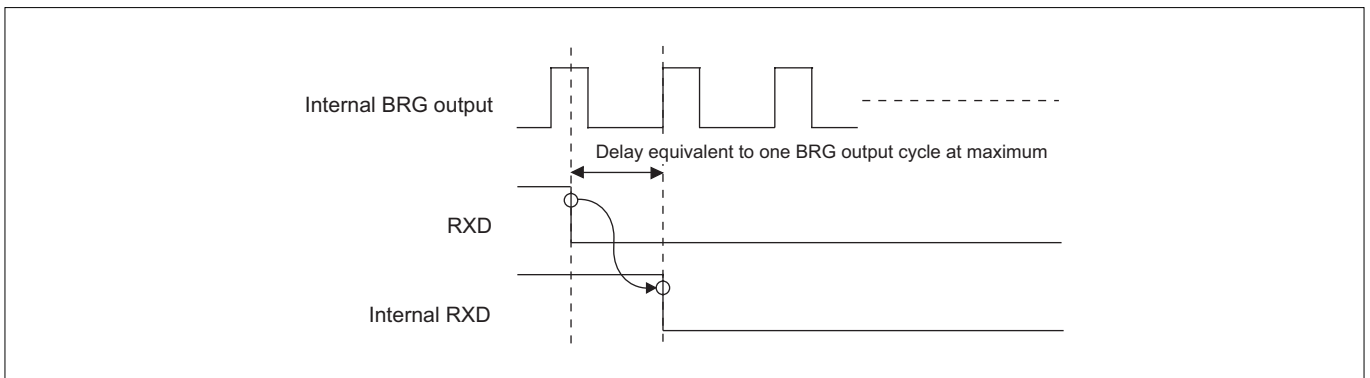
The start bit is sampled synchronously with the internal BRG output. If the received signal remains "L" for 8 BRG output cycles after the falling edge of the start bit, the CPU recognizes that part of the received signal as the start bit and starts latching the received data another 8 cycles after that, beginning with the LSB (first bit). If some sampled part of the received signal is "H" before being determined to be the start bit, the CPU starts hunting the falling edge of the received signal again. Because the start bit is sampled synchronously with the internal BRG output, there is a delay equivalent to one BRG output cycle at maximum. The subsequent received data is latched into the internal circuit with that delayed timing.



**Figure 12.7.5 Start Bit Detection and Data Sampling Timing**



**Figure 12.7.6 Example of an Invalid Start Bit (Not Received)**



**Figure 12.7.7 Delay in Receive Timing**



#### 12.8 Fixed Period Clock Output Function

When using SIO0, SIO1, SIO4 or SIO5 in UART mode, the relevant port (P84, P87, P105 or P93) can be switched for use as an SCLKO0, SCLKO1, SCLKO4 or SCLKO5 pin, respectively. That way, a BRG output clock divided by 2 can be output from the SCLKO pin.

Note: • This clock is output not just during data transfer.

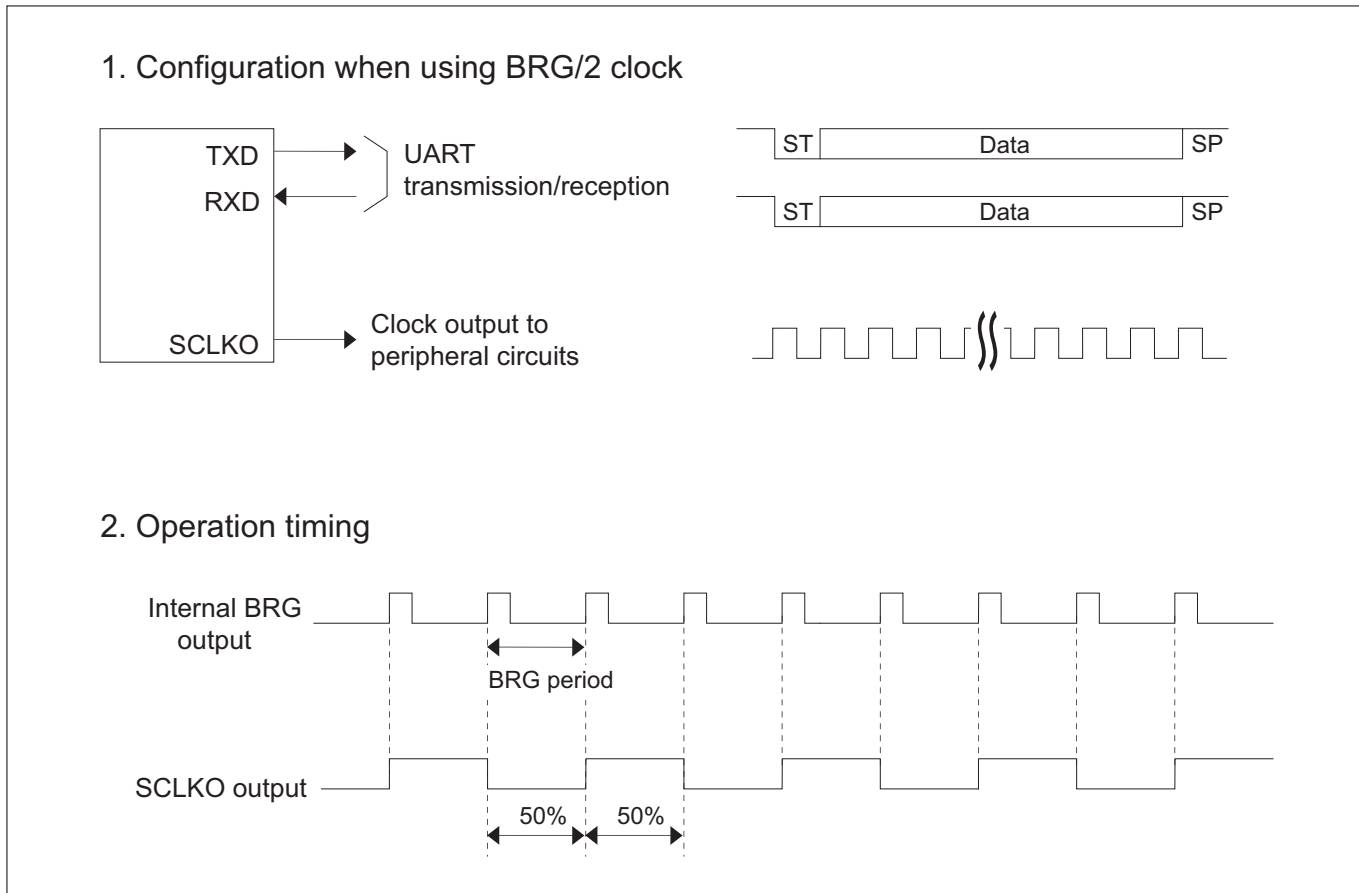


Figure 12.8.1 Example of Fixed Period Clock Output

## 12.9 Notes on Using UART Mode

### • Settings of SIO Transmit/Receive Mode Register and SIO Baud Rate Register

The SIO Transmit/Receive Mode Register, SIO Special Mode Register and SIO Baud Rate Register and the Transmit Control Register's BRG count source select bit must always be set when the serial interface is not operating. If a transmit or receive operation is in progress, wait until the transmit and receive operations are finished and then clear the transmit and receive enable bits before making changes.

### • Settings of SIO Baud Rate Register

Writes to the SIO Baud Rate Register take effect in the next cycle after the BRG counter has finished counting. However, if the register is accessed for write while transmission and reception are disabled, the written value takes effect at the same time it is written.

### • Transmission/reception using DMA

To transmit/receive data in DMA request mode, enable the DMAC to accept transfer requests (by setting the DMA Mode Register) before serial communication starts.

### • About overrun error

If all bits of the next received data have been set in the SIO Receive Shift Register before reading out the SIO Receive Buffer Register (i.e., an overrun error occurred), the received data is not stored in the receive buffer register, with the previous received data retained in it. Once an overrun error occurs, although a receive operation continues, the subsequent received data is not stored in the receive buffer register. Before normal receive operation can be restarted, the receive enable bit must be temporarily cleared. And this is the only way that the overrun error flag can be cleared.

### • Flags showing the status of UART receive operation

There are following flags that indicate the status of receive operation during UART mode:

- SIO Receive Control Register receive status bit
- SIO Receive Control Register reception finished bit
- SIO Receive Control Register receive error sum bit
- SIO Receive Control Register overrun error bit
- SIO Receive Control Register parity error bit
- SIO Receive Control Register framing error bit

The manner in which the reception finished bit and various error flags are cleared differs depending on whether an overrun error occurred, as described below.

[When an overrun error did not occur]

Cleared by reading out the lower byte of the receive buffer register or by clearing the receive enable bit.

[When an overrun error occurred]

Cleared by only clearing the receive enable bit.

### • Switching from general-purpose to serial interface pin

When switching from general-purpose port to the serial interface pin by the port operation mode register, the terminal TXDn pin outputs "H" level.

## **CHAPTER 13**

---

# **CAN MODULE**

- 13.1 Outline of the CAN Module
- 13.2 CAN Module Related Registers
- 13.3 CAN Protocol
- 13.4 Initializing the CAN Module
- 13.5 Transmitting Data Frames
- 13.6 Receiving Data Frames
- 13.7 Transmitting Remote Frames
- 13.8 Receiving Remote Frames
- 13.9 Notes on CAN Module

### 13.1 Outline of the CAN Module

The 32192/32195/32196 contains two-channel Full CAN modules compliant with CAN (Controller Area Network) Specification V2.0B Active. These CAN modules each have 32 message slots and four mask registers, effective use of which helps to reduce the data processing load of the CPU.

The CAN modules are outlined below.

Table 13.1.1 Outline of the CAN Module

Item	Description
Protocol	CAN Specification V2.0B Active
Number of message slots	Total 32 slots (30 global slots, two local slots)
Polarity	0: Dominant 1: Recessive
Acceptance filter (Function to receive only a range of IDs specified by receive ID filter)	Global mask: 2 Local mask: 2
Baud rate	1 time quantum (Tq) = (BRP + 1) / (CPUCLK/4) (BRP: Baud Rate Prescaler set value) $\text{Baud rate} = \frac{1}{\text{Tq period} \times \text{number of Tq's for one bit}} \dots \text{Max 1 Mbps (Note 1)}$ BRP: 1–255 (0: inhibited) Number of Tq's for one bit = Synchronization Segment + Propagation Segment + Phase Segment 1 + Phase Segment 2 Synchronization Segment: 1Tq Propagation Segment: 1–8Tq Phase Segment 1: 1–8Tq Phase Segment 2: 1–8Tq (IPT = 1)
Remote frame automatic response function	The slot that received a remote frame responds by automatically sending a data frame.
Timestamp function	This function is implemented using a 16-bit counter. The count period is derived from the CAN bus bit period by dividing it by 1, 2, 3 or 4.
BasicCAN mode	Slot 30 and slot 31 can be alternately received as received-only.
Transmit abort function	Transmit requests can be canceled.
Loopback function	The CAN module receives the data transmitted by the module itself.
Return bus off function	Error active mode is forcibly entered into after clearing the error counter.
Single shot function	Transmission is not retried even when it failed due to arbitration-lost or a transmit error.
DMA transfer function	DMA transfer request is generated when transmission failed or transmit/receive operation finished.
Self-diagnostic function	Communication module is diagnosed by communicating internally in the CAN module.

Note 1: The maximum allowable error of oscillation depends on the system configuration (e.g., bus length, clock error, CAN bus transceiver, sampling position and bit configuration).

Table 13.1.2 DMA Transfer Requests Generated by CAN

DMA Transfer Request by CAN	DMAC Input Channel
CAN0: Slot 0 transmission failed or slot 31 transmit/receive operation finished	DMA0, DMA6
CAN0: Slot 1 transmission failed or slot 30 transmit/receive operation finished	DMA2, DMA7
CAN1: Slot 0 transmission failed or slot 31 transmit/receive operation finished	DMA5, DMA8
CAN1: Slot 1 transmission failed or slot 30 transmit/receive operation finished	DMA7, DMA9

Table 13.1.3 Interrupt Requests Generated by CAN Modules

CAN Module Interrupt Request Source	ICU Interrupt Request Source
CAN0 transmission completed	CAN0 transmit/receive & error interrupt, CAN0 transmit/receive completion interrupt
CAN1 transmission completed	CAN1 transmit/receive & error interrupt, CAN1 transmit/receive completion interrupt
CAN0 reception completed	CAN0 transmit/receive & error interrupt, CAN0 transmit/receive completion interrupt
CAN1 reception completed	CAN1 transmit/receive & error interrupt, CAN1 transmit/receive completion interrupt
CAN0 bus error	CAN0 transmit/receive & error interrupt, CAN0 error interrupt
CAN1 bus error	CAN1 transmit/receive & error interrupt, CAN1 error interrupt
CAN0 error passive	CAN0 transmit/receive & error interrupt, CAN0 error interrupt
CAN1 error passive	CAN1 transmit/receive & error interrupt, CAN1 error interrupt
CAN0 bus off	CAN0 transmit/receive & error interrupt, CAN0 error interrupt
CAN1 bus off	CAN1 transmit/receive & error interrupt, CAN1 error interrupt
CAN0 single shot	CAN0 transmit/receive & error interrupt, CAN0 single-shot interrupt
CAN1 single shot	CAN1 transmit/receive & error interrupt, CAN1 single-shot interrupt

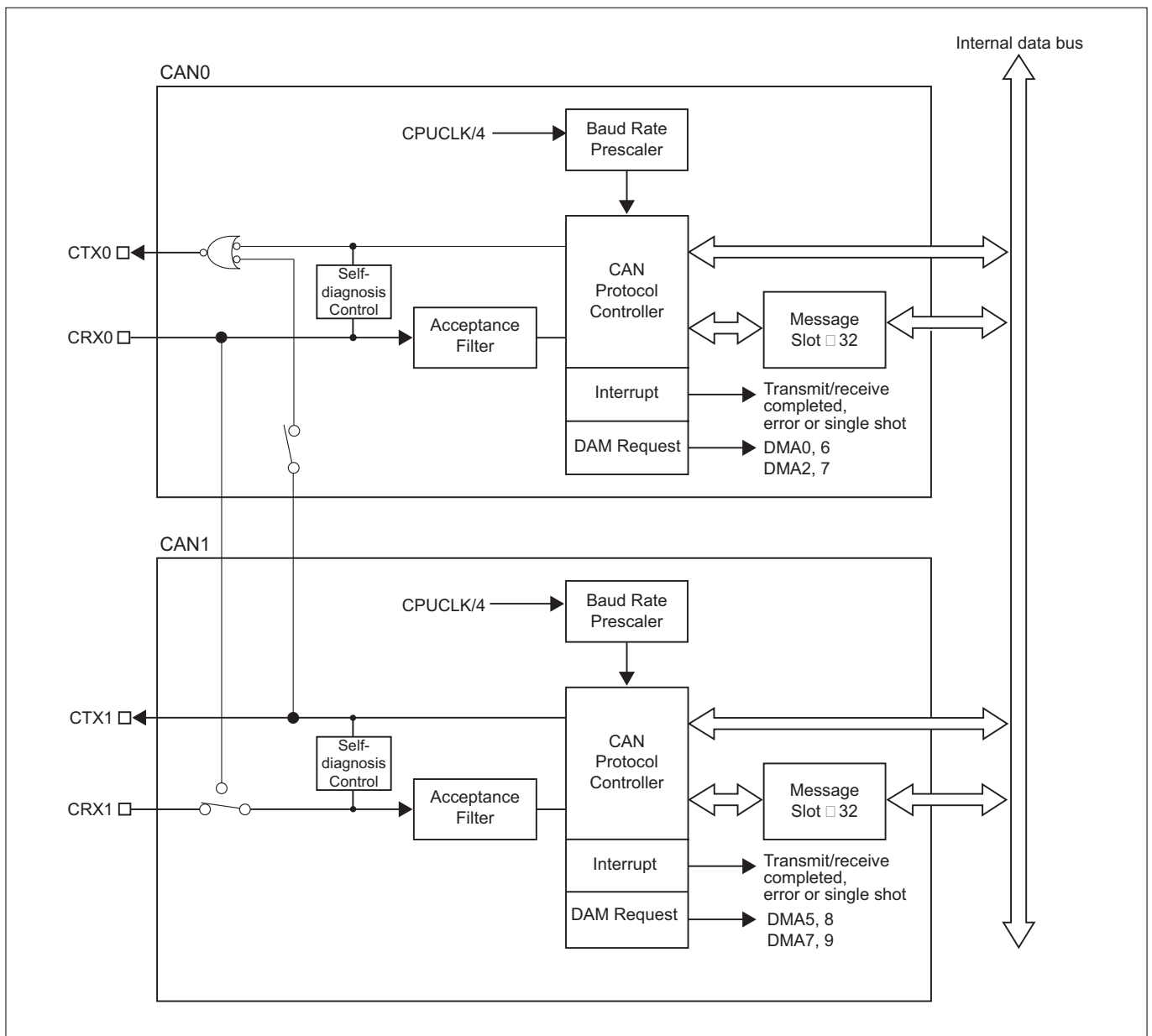


Figure 13.1.1 Block Diagram of the CAN Modules

## 13.2 CAN Module Related Registers

Shown below is a CAN module related register map.

CAN Module Related Register Map (1/19)

Address	+0 address	+1 address	See pages
	b0	b7 b8	b15
H'0080 052A	CAN Bus Mode Control Register (CANBUSCR)		13-23
H'0080 1000	CAN0 Control Register (CAN0CNT)		13-26
H'0080 1002	CAN0 Status Register (CAN0STAT)		13-29
H'0080 1004	(Use inhibited area)		
H'0080 1006	CAN0 Configuration Register (CAN0CONF)		13-32
H'0080 1008	CAN0 Timestamp Count Register (CAN0TSTMP)		13-35
H'0080 100A	CAN0 Receive Error Count Register (CAN0REC)	CAN0 Transmit Error Count Register (CAN0TEC)	13-36
H'0080 100C	CAN0 Slot Interrupt Request Status Register (CAN0SLISTW)		(Upper) 13-40 (CAN0SLIST)
H'0080 100E			(Lower) (CAN0SLISTL)
H'0080 1010	CAN0 Slot Interrupt Request Mask Register (CAN0SLIMKW)		(Upper) 13-42 (CANSLIMK)
H'0080 1012			(Lower) (CAN0SLIMKL)
H'0080 1014	CAN0 Error Interrupt Request Status Register (CAN0ERIST)	CAN0 Error Interrupt Request Mask Register (CAN0ERIMK)	13-43 13-44
H'0080 1016	CAN0 Baud Rate Prescaler (CAN0BRP)	CAN0 Cause of Error Register (CAN0EF)	13-37 13-67
H'0080 1018	CAN0 Mode Register (CAN0MOD)	CAN0 DMA Transfer Request Select Register (CAN0DMARQ)	13-69 13-70
H'0080 101A	CAN0 Message Slot Number Register (CAN0MSN)	CAN0 Clock Select Register (CAN0CKSEL)	13-71 13-72
H'0080 101C	CAN0 Frame Format Select Register (CAN0FFSW)		(Upper) 13-74 (CAN0FFS)
H'0080 101E			(Lower) (CAN0FFSL)
H'0080 1020	CAN0 Global Mask Register A Standard ID0 (C0GMSKAS0)	CAN0 Global Mask Register A Standard ID1 (C0GMSKAS1)	13-76
H'0080 1022	CAN0 Global Mask Register A Extended ID0 (C0GMSKAE0)	CAN0 Global Mask Register A Extended ID1 (C0GMSKAE1)	13-77
H'0080 1024	CAN0 Global Mask Register A Extended ID2 (C0GMSKAE2)	(Use inhibited area)	13-78
H'0080 1026	(Use inhibited area)		
H'0080 1028	CAN0 Global Mask Register B Standard ID0 (C0GMSKBS0)	CAN0 Global Mask Register B Standard ID1 (C0GMSKBS1)	13-76
H'0080 102A	CAN0 Global Mask Register B Extended ID0 (C0GMSKBE0)	CAN0 Global Mask Register B Extended ID1 (C0GMSKBE1)	13-77
H'0080 102C	CAN0 Global Mask Register B Extended ID2 (C0GMSKBE2)	(Use inhibited area)	13-78
H'0080 102E	(Use inhibited area)		
H'0080 1030	CAN0 Local Mask Register A Standard ID0 (C0LMSKAS0)	CAN0 Local Mask Register A Standard ID1 (C0LMSKAS1)	13-76
H'0080 1032	CAN0 Local Mask Register A Extended ID0 (C0LMSKAE0)	CAN0 Local Mask Register A Extended ID1 (C0LMSKAE1)	13-77
H'0080 1034	CAN0 Local Mask Register A Extended ID2 (C0LMSKAE2)	(Use inhibited area)	13-78
H'0080 1036	(Use inhibited area)		
H'0080 1038	CAN0 Local Mask Register B Standard ID0 (C0LMSKBS0)	CAN0 Local Mask Register B Standard ID1 (C0LMSKBS1)	13-76
H'0080 103A	CAN0 Local Mask Register B Extended ID0 (C0LMSKBE0)	CAN0 Local Mask Register B Extended ID1 (C0LMSKBE1)	13-77

CAN Module Related Register Map (2/19)

Address	+0 address		+1 address		See pages
	b0	b7	b8	b15	
H'0080 103C	CAN0 Local Mask Register B Extended ID2 (C0LMSKBE2)		(Use inhibited area)		13-78
H'0080 103E	(Use inhibited area)				
H'0080 1040	CAN0 Single-Shot Mode Control Register (CAN0SSMODEW)		(Upper) (CAN0SSMODE)		13-80
H'0080 1042	(Lower) (CAN0SSMODEL)				
H'0080 1044	CAN0 Single-Shot Interrupt Request Status Register (CAN0SSISTW)		(Upper) (CAN0SSIST)		13-45
H'0080 1046	(Lower) (CAN0SSISTL)				
H'0080 1048	CAN0 Single-Shot Interrupt Request Mask Register (CAN0SSIMKW)		(Upper) (CAN0SSIMK)		13-47
H'0080 104A	(Lower) (CAN0SSIMKL)				
H'0080 104C	(Use inhibited area)				
H'0080 104E	(Use inhibited area)				
H'0080 1050	CAN0 Message Slot 0 Control Register (C0MSL0CNT)		CAN0 Message Slot 1 Control Register (C0MSL1CNT)		13-82
H'0080 1052	CAN0 Message Slot 2 Control Register (C0MSL2CNT)		CAN0 Message Slot 3 Control Register (C0MSL3CNT)		13-82
H'0080 1054	CAN0 Message Slot 4 Control Register (C0MSL4CNT)		CAN0 Message Slot 5 Control Register (C0MSL5CNT)		13-82
H'0080 1056	CAN0 Message Slot 6 Control Register (C0MSL6CNT)		CAN0 Message Slot 7 Control Register (C0MSL7CNT)		13-82
H'0080 1058	CAN0 Message Slot 8 Control Register (C0MSL8CNT)		CAN0 Message Slot 9 Control Register (C0MSL9CNT)		13-82
H'0080 105A	CAN0 Message Slot 10 Control Register (C0MSL10CNT)		CAN0 Message Slot 11 Control Register (C0MSL11CNT)		13-82
H'0080 105C	CAN0 Message Slot 12 Control Register (C0MSL12CNT)		CAN0 Message Slot 13 Control Register (C0MSL13CNT)		13-82
H'0080 105E	CAN0 Message Slot 14 Control Register (C0MSL14CNT)		CAN0 Message Slot 15 Control Register (C0MSL15CNT)		13-82
H'0080 1060	CAN0 Message Slot 16 Control Register (C0MSL16CNT)		CAN0 Message Slot 17 Control Register (C0MSL17CNT)		13-82
H'0080 1062	CAN0 Message Slot 18 Control Register (C0MSL18CNT)		CAN0 Message Slot 19 Control Register (C0MSL19CNT)		13-82
H'0080 1064	CAN0 Message Slot 20 Control Register (C0MSL20CNT)		CAN0 Message Slot 21 Control Register (C0MSL21CNT)		13-82
H'0080 1066	CAN0 Message Slot 22 Control Register (C0MSL22CNT)		CAN0 Message Slot 23 Control Register (C0MSL23CNT)		13-82
H'0080 1068	CAN0 Message Slot 24 Control Register (C0MSL24CNT)		CAN0 Message Slot 25 Control Register (C0MSL25CNT)		13-82
H'0080 106A	CAN0 Message Slot 26 Control Register (C0MSL26CNT)		CAN0 Message Slot 27 Control Register (C0MSL27CNT)		13-82
H'0080 106C	CAN0 Message Slot 28 Control Register (C0MSL28CNT)		CAN0 Message Slot 29 Control Register (C0MSL29CNT)		13-82
H'0080 106E	CAN0 Message Slot 30 Control Register (C0MSL30CNT)		CAN0 Message Slot 31 Control Register (C0MSL31CNT)		13-82
	(Use inhibited area)				
H'0080 1100	CAN0 Message Slot 0 Standard ID0 (C0MSL0SID0)		CAN0 Message Slot 0 Standard ID1 (C0MSL0SID1)		13-86 13-88
H'0080 1102	CAN0 Message Slot 0 Extended ID0 (C0MSL0EID0)		CAN0 Message Slot 0 Extended ID1 (C0MSL0EID1)		13-90 13-92
H'0080 1104	CAN0 Message Slot 0 Extended ID2 (C0MSL0EID2)		CAN0 Message Slot 0 Data Length Register (C0MSL0DLC)		13-94 13-96
H'0080 1106	CAN0 Message Slot 0 Data 0 (C0MSL0DT0)		CAN0 Message Slot 0 Data 1 (C0MSL0DT1)		13-98 13-100
H'0080 1108	CAN0 Message Slot 0 Data 2 (C0MSL0DT2)		CAN0 Message Slot 0 Data 3 (C0MSL0DT3)		13-102 13-104
H'0080 110A	CAN0 Message Slot 0 Data 4 (C0MSL0DT4)		CAN0 Message Slot 0 Data 5 (C0MSL0DT5)		13-106 13-108
H'0080 110C	CAN0 Message Slot 0 Data 6 (C0MSL0DT6)		CAN0 Message Slot 0 Data 7 (C0MSL0DT7)		13-110 13-112
H'0080 110E	CAN0 Message Slot 0 Timestamp (C0MSL0TSP)				13-114

CAN Module Related Register Map (3/19)

Address	+0 address		+1 address		See pages
	b0	b7	b8	b15	
H'0080 1110	CAN0 Message Slot 1 Standard ID0 (C0MSL1SID0)		CAN0 Message Slot 1 Standard ID1 (C0MSL1SID1)		13-86 13-88
H'0080 1112	CAN0 Message Slot 1 Extended ID0 (C0MSL1EID0)		CAN0 Message Slot 1 Extended ID1 (C0MSL1EID1)		13-90 13-92
H'0080 1114	CAN0 Message Slot 1 Extended ID2 (C0MSL1EID2)		CAN0 Message Slot 1 Data Length Register (C0MSL1DLC)		13-94 13-96
H'0080 1116	CAN0 Message Slot 1 Data 0 (C0MSL1DT0)		CAN0 Message Slot 1 Data 1 (C0MSL1DT1)		13-98 13-100
H'0080 1118	CAN0 Message Slot 1 Data 2 (C0MSL1DT2)		CAN0 Message Slot 1 Data 3 (C0MSL1DT3)		13-102 13-104
H'0080 111A	CAN0 Message Slot 1 Data 4 (C0MSL1DT4)		CAN0 Message Slot 1 Data 5 (C0MSL1DT5)		13-106 13-108
H'0080 111C	CAN0 Message Slot 1 Data 6 (C0MSL1DT6)		CAN0 Message Slot 1 Data 7 (C0MSL1DT7)		13-110 13-112
H'0080 111E	CAN0 Message Slot 1 Timestamp (C0MSL1TSP)				13-114
H'0080 1120	CAN0 Message Slot 2 Standard ID0 (C0MSL2SID0)		CAN0 Message Slot 2 Standard ID1 (C0MSL2SID1)		13-86 13-88
H'0080 1122	CAN0 Message Slot 2 Extended ID0 (C0MSL2EID0)		CAN0 Message Slot 2 Extended ID1 (C0MSL2EID1)		13-90 13-92
H'0080 1124	CAN0 Message Slot 2 Extended ID2 (C0MSL2EID2)		CAN0 Message Slot 2 Data Length Register (C0MSL2DLC)		13-94 13-96
H'0080 1126	CAN0 Message Slot 2 Data 0 (C0MSL2DT0)		CAN0 Message Slot 2 Data 1 (C0MSL2DT1)		13-98 13-100
H'0080 1128	CAN0 Message Slot 2 Data 2 (C0MSL2DT2)		CAN0 Message Slot 2 Data 3 (C0MSL2DT3)		13-102 13-104
H'0080 112A	CAN0 Message Slot 2 Data 4 (C0MSL2DT4)		CAN0 Message Slot 2 Data 5 (C0MSL2DT5)		13-106 13-108
H'0080 112C	CAN0 Message Slot 2 Data 6 (C0MSL2DT6)		CAN0 Message Slot 2 Data 7 (C0MSL2DT7)		13-110 13-112
H'0080 112E	CAN0 Message Slot 2 Timestamp (C0MSL2TSP)				13-114
H'0080 1130	CAN0 Message Slot 3 Standard ID0 (C0MSL3SID0)		CAN0 Message Slot 3 Standard ID1 (C0MSL3SID1)		13-86 13-88
H'0080 1132	CAN0 Message Slot 3 Extended ID0 (C0MSL3EID0)		CAN0 Message Slot 3 Extended ID1 (C0MSL3EID1)		13-90 13-92
H'0080 1134	CAN0 Message Slot 3 Extended ID2 (C0MSL3EID2)		CAN0 Message Slot 3 Data Length Register (C0MSL3DLC)		13-94 13-96
H'0080 1136	CAN0 Message Slot 3 Data 0 (C0MSL3DT0)		CAN0 Message Slot 3 Data 1 (C0MSL3DT1)		13-98 13-100
H'0080 1138	CAN0 Message Slot 3 Data 2 (C0MSL3DT2)		CAN0 Message Slot 3 Data 3 (C0MSL3DT3)		13-102 13-104
H'0080 113A	CAN0 Message Slot 3 Data 4 (C0MSL3DT4)		CAN0 Message Slot 3 Data 5 (C0MSL3DT5)		13-106 13-108
H'0080 113C	CAN0 Message Slot 3 Data 6 (C0MSL3DT6)		CAN0 Message Slot 3 Data 7 (C0MSL3DT7)		13-110 13-112
H'0080 113E	CAN0 Message Slot 3 Timestamp (C0MSL3TSP)				13-114
H'0080 1140	CAN0 Message Slot 4 Standard ID0 (C0MSL4SID0)		CAN0 Message Slot 4 Standard ID1 (C0MSL4SID1)		13-86 13-88
H'0080 1142	CAN0 Message Slot 4 Extended ID0 (C0MSL4EID0)		CAN0 Message Slot 4 Extended ID1 (C0MSL4EID1)		13-90 13-92
H'0080 1144	CAN0 Message Slot 4 Extended ID2 (C0MSL4EID2)		CAN0 Message Slot 4 Data Length Register (C0MSL4DLC)		13-94 13-96
H'0080 1146	CAN0 Message Slot 4 Data 0 (C0MSL4DT0)		CAN0 Message Slot 4 Data 1 (C0MSL4DT1)		13-98 13-100
H'0080 1148	CAN0 Message Slot 4 Data 2 (C0MSL4DT2)		CAN0 Message Slot 4 Data 3 (C0MSL4DT3)		13-102 13-104
H'0080 114A	CAN0 Message Slot 4 Data 4 (C0MSL4DT4)		CAN0 Message Slot 4 Data 5 (C0MSL4DT5)		13-106 13-108
H'0080 114C	CAN0 Message Slot 4 Data 6 (C0MSL4DT6)		CAN0 Message Slot 4 Data 7 (C0MSL4DT7)		13-110 13-112
H'0080 114E	CAN0 Message Slot 4 Timestamp (C0MSL4TSP)				13-114
H'0080 1150	CAN0 Message Slot 5 Standard ID0 (C0MSL5SID0)		CAN0 Message Slot 5 Standard ID1 (C0MSL5SID1)		13-86 13-88
H'0080 1152	CAN0 Message Slot 5 Extended ID0 (C0MSL5EID0)		CAN0 Message Slot 5 Extended ID1 (C0MSL5EID1)		13-90 13-92



CAN Module Related Register Map (4/19)

Address	+0 address		+1 address		See pages
	b0	b7	b8	b15	
H'0080 1154	CAN0 Message Slot 5 Extended ID2 (C0MSL5EID2)		CAN0 Message Slot 5 Data Length Register (C0MSL5DLC)		13-94 13-96
H'0080 1156	CAN0 Message Slot 5 Data 0 (C0MSL5DT0)		CAN0 Message Slot 5 Data 1 (C0MSL5DT1)		13-98 13-100
H'0080 1158	CAN0 Message Slot 5 Data 2 (C0MSL5DT2)		CAN0 Message Slot 5 Data 3 (C0MSL5DT3)		13-102 13-104
H'0080 115A	CAN0 Message Slot 5 Data 4 (C0MSL5DT4)		CAN0 Message Slot 5 Data 5 (C0MSL5DT5)		13-106 13-108
H'0080 115C	CAN0 Message Slot 5 Data 6 (C0MSL5DT6)		CAN0 Message Slot 5 Data 7 (C0MSL5DT7)		13-110 13-112
H'0080 115E	CAN0 Message Slot 5 Timestamp (C0MSL5TSP)				13-114
H'0080 1160	CAN0 Message Slot 6 Standard ID0 (C0MSL6SID0)		CAN0 Message Slot 6 Standard ID1 (C0MSL6SID1)		13-86 13-88
H'0080 1162	CAN0 Message Slot 6 Extended ID0 (C0MSL6EID0)		CAN0 Message Slot 6 Extended ID1 (C0MSL6EID1)		13-90 13-92
H'0080 1164	CAN0 Message Slot 6 Extended ID2 (C0MSL6EID2)		CAN0 Message Slot 6 Data Length Register (C0MSL6DLC)		13-94 13-96
H'0080 1166	CAN0 Message Slot 6 Data 0 (C0MSL6DT0)		CAN0 Message Slot 6 Data 1 (C0MSL6DT1)		13-98 13-100
H'0080 1168	CAN0 Message Slot 6 Data 2 (C0MSL6DT2)		CAN0 Message Slot 6 Data 3 (C0MSL6DT3)		13-102 13-104
H'0080 116A	CAN0 Message Slot 6 Data 4 (C0MSL6DT4)		CAN0 Message Slot 6 Data 5 (C0MSL6DT5)		13-106 13-108
H'0080 116C	CAN0 Message Slot 6 Data 6 (C0MSL6DT6)		CAN0 Message Slot 6 Data 7 (C0MSL6DT7)		13-110 13-112
H'0080 116E	CAN0 Message Slot 6 Timestamp (C0MSL6TSP)				13-114
H'0080 1170	CAN0 Message Slot 7 Standard ID0 (C0MSL7SID0)		CAN0 Message Slot 7 Standard ID1 (C0MSL7SID1)		13-86 13-88
H'0080 1172	CAN0 Message Slot 7 Extended ID0 (C0MSL7EID0)		CAN0 Message Slot 7 Extended ID1 (C0MSL7EID1)		13-90 13-92
H'0080 1174	CAN0 Message Slot 7 Extended ID2 (C0MSL7EID2)		CAN0 Message Slot 7 Data Length Register (C0MSL7DLC)		13-94 13-96
H'0080 1176	CAN0 Message Slot 7 Data 0 (C0MSL7DT0)		CAN0 Message Slot 7 Data 1 (C0MSL7DT1)		13-98 13-100
H'0080 1178	CAN0 Message Slot 7 Data 2 (C0MSL7DT2)		CAN0 Message Slot 7 Data 3 (C0MSL7DT3)		13-102 13-104
H'0080 117A	CAN0 Message Slot 7 Data 4 (C0MSL7DT4)		CAN0 Message Slot 7 Data 5 (C0MSL7DT5)		13-106 13-108
H'0080 117C	CAN0 Message Slot 7 Data 6 (C0MSL7DT6)		CAN0 Message Slot 7 Data 7 (C0MSL7DT7)		13-110 13-112
H'0080 117E	CAN0 Message Slot 7 Timestamp (C0MSL7TSP)				13-114
H'0080 1180	CAN0 Message Slot 8 Standard ID0 (C0MSL8SID0)		CAN0 Message Slot 8 Standard ID1 (C0MSL8SID1)		13-86 13-88
H'0080 1182	CAN0 Message Slot 8 Extended ID0 (C0MSL8EID0)		CAN0 Message Slot 8 Extended ID1 (C0MSL8EID1)		13-90 13-92
H'0080 1184	CAN0 Message Slot 8 Extended ID2 (C0MSL8EID2)		CAN0 Message Slot 8 Data Length Register (C0MSL8DLC)		13-94 13-96
H'0080 1186	CAN0 Message Slot 8 Data 0 (C0MSL8DT0)		CAN0 Message Slot 8 Data 1 (C0MSL8DT1)		13-98 13-100
H'0080 1188	CAN0 Message Slot 8 Data 2 (C0MSL8DT2)		CAN0 Message Slot 8 Data 3 (C0MSL8DT3)		13-102 13-104
H'0080 118A	CAN0 Message Slot 8 Data 4 (C0MSL8DT4)		CAN0 Message Slot 8 Data 5 (C0MSL8DT5)		13-106 13-108
H'0080 118C	CAN0 Message Slot 8 Data 6 (C0MSL8DT6)		CAN0 Message Slot 8 Data 7 (C0MSL8DT7)		13-110 13-112
H'0080 118E	CAN0 Message Slot 8 Timestamp (C0MSL8TSP)				13-114
H'0080 1190	CAN0 Message Slot 9 Standard ID0 (C0MSL9SID0)		CAN0 Message Slot 9 Standard ID1 (C0MSL9SID1)		13-86 13-88
H'0080 1192	CAN0 Message Slot 9 Extended ID0 (C0MSL9EID0)		CAN0 Message Slot 9 Extended ID1 (C0MSL9EID1)		13-90 13-92
H'0080 1194	CAN0 Message Slot 9 Extended ID2 (C0MSL9EID2)		CAN0 Message Slot 9 Data Length Register (C0MSL9DLC)		13-94 13-96
H'0080 1196	CAN0 Message Slot 9 Data 0 (C0MSL9DT0)		CAN0 Message Slot 9 Data 1 (C0MSL9DT1)		13-98 13-100
H'0080 1198	CAN0 Message Slot 9 Data 2 (C0MSL9DT2)		CAN0 Message Slot 9 Data 3 (C0MSL9DT3)		13-102 13-104

## CAN Module Related Register Map (5/19)

Address	+0 address		+1 address		See pages
	b0	b7	b8	b15	
H'0080 119A	CAN0 Message Slot 9 Data 4 (C0MSL9DT4)		CAN0 Message Slot 9 Data 5 (C0MSL9DT5)		13-106 13-108
H'0080 119C	CAN0 Message Slot 9 Data 6 (C0MSL9DT6)		CAN0 Message Slot 9 Data 7 (C0MSL9DT7)		13-110 13-112
H'0080 119E	CAN0 Message Slot 9 Timestamp (C0MSL9TSP)				13-114
H'0080 11A0	CAN0 Message Slot 10 Standard ID0 (C0MSL10SID0)		CAN0 Message Slot 10 Standard ID1 (C0MSL10SID1)		13-86 13-88
H'0080 11A2	CAN0 Message Slot 10 Extended ID0 (C0MSL10EID0)		CAN0 Message Slot 10 Extended ID1 (C0MSL10EID1)		13-90 13-92
H'0080 11A4	CAN0 Message Slot 10 Extended ID2 (C0MSL10EID2)		CAN0 Message Slot 10 Data Length Register (C0MSL10DLC)		13-94 13-96
H'0080 11A6	CAN0 Message Slot 10 Data 0 (C0MSL10DT0)		CAN0 Message Slot 10 Data 1 (C0MSL10DT1)		13-98 13-100
H'0080 11A8	CAN0 Message Slot 10 Data 2 (C0MSL10DT2)		CAN0 Message Slot 10 Data 3 (C0MSL10DT3)		13-102 13-104
H'0080 11AA	CAN0 Message Slot 10 Data 4 (C0MSL10DT4)		CAN0 Message Slot 10 Data 5 (C0MSL10DT5)		13-106 13-108
H'0080 11AC	CAN0 Message Slot 10 Data 6 (C0MSL10DT6)		CAN0 Message Slot 10 Data 7 (C0MSL10DT7)		13-110 13-112
H'0080 11AE	CAN0 Message Slot 10 Timestamp (C0MSL10TSP)				13-114
H'0080 11B0	CAN0 Message Slot 11 Standard ID0 (C0MSL11SID0)		CAN0 Message Slot 11 Standard ID1 (C0MSL11SID1)		13-86 13-88
H'0080 11B2	CAN0 Message Slot 11 Extended ID0 (C0MSL11EID0)		CAN0 Message Slot 11 Extended ID1 (C0MSL11EID1)		13-90 13-92
H'0080 11B4	CAN0 Message Slot 11 Extended ID2 (C0MSL11EID2)		CAN0 Message Slot 11 Data Length Register (C0MSL11DLC)		13-94 13-96
H'0080 11B6	CAN0 Message Slot 11 Data 0 (C0MSL11DT0)		CAN0 Message Slot 11 Data 1 (C0MSL11DT1)		13-98 13-100
H'0080 11B8	CAN0 Message Slot 11 Data 2 (C0MSL11DT2)		CAN0 Message Slot 11 Data 3 (C0MSL11DT3)		13-102 13-104
H'0080 11BA	CAN0 Message Slot 11 Data 4 (C0MSL11DT4)		CAN0 Message Slot 11 Data 5 (C0MSL11DT5)		13-106 13-108
H'0080 11BC	CAN0 Message Slot 11 Data 6 (C0MSL11DT6)		CAN0 Message Slot 11 Data 7 (C0MSL11DT7)		13-110 13-112
H'0080 11BE	CAN0 Message Slot 11 Timestamp (C0MSL11TSP)				13-114
H'0080 11C0	CAN0 Message Slot 12 Standard ID0 (C0MSL12SID0)		CAN0 Message Slot 12 Standard ID1 (C0MSL12SID1)		13-86 13-88
H'0080 11C2	CAN0 Message Slot 12 Extended ID0 (C0MSL12EID0)		CAN0 Message Slot 12 Extended ID1 (C0MSL12EID1)		13-90 13-92
H'0080 11C4	CAN0 Message Slot 12 Extended ID2 (C0MSL12EID2)		CAN0 Message Slot 12 Data Length Register (C0MSL12DLC)		13-94 13-96
H'0080 11C6	CAN0 Message Slot 12 Data 0 (C0MSL12DT0)		CAN0 Message Slot 12 Data 1 (C0MSL12DT1)		13-98 13-100
H'0080 11C8	CAN0 Message Slot 12 Data 2 (C0MSL12DT2)		CAN0 Message Slot 12 Data 3 (C0MSL12DT3)		13-102 13-104
H'0080 11CA	CAN0 Message Slot 12 Data 4 (C0MSL12DT4)		CAN0 Message Slot 12 Data 5 (C0MSL12DT5)		13-106 13-108
H'0080 11CC	CAN0 Message Slot 12 Data 6 (C0MSL12DT6)		CAN0 Message Slot 12 Data 7 (C0MSL12DT7)		13-110 13-112
H'0080 11CE	CAN0 Message Slot 12 Timestamp (C0MSL12TSP)				13-114
H'0080 11D0	CAN0 Message Slot 13 Standard ID0 (C0MSL13SID0)		CAN0 Message Slot 13 Standard ID1 (C0MSL13SID1)		13-86 13-88
H'0080 11D2	CAN0 Message Slot 13 Extended ID0 (C0MSL13EID0)		CAN0 Message Slot 13 Extended ID1 (C0MSL13EID1)		13-90 13-92
H'0080 11D4	CAN0 Message Slot 13 Extended ID2 (C0MSL13EID2)		CAN0 Message Slot 13 Data Length Register (C0MSL13DLC)		13-94 13-96
H'0080 11D6	CAN0 Message Slot 13 Data 0 (C0MSL13DT0)		CAN0 Message Slot 13 Data 1 (C0MSL13DT1)		13-98 13-100
H'0080 11D8	CAN0 Message Slot 13 Data 2 (C0MSL13DT2)		CAN0 Message Slot 13 Data 3 (C0MSL13DT3)		13-102 13-104
H'0080 11DA	CAN0 Message Slot 13 Data 4 (C0MSL13DT4)		CAN0 Message Slot 13 Data 5 (C0MSL13DT5)		13-106 13-108
H'0080 11DC	CAN0 Message Slot 13 Data 6 (C0MSL13DT6)		CAN0 Message Slot 13 Data 7 (C0MSL13DT7)		13-110 13-112
H'0080 11DE	CAN0 Message Slot 13 Timestamp (C0MSL13TSP)				13-114

CAN Module Related Register Map (6/19)

Address	+0 address		+1 address		See pages
	b0	b7	b8	b15	
H'0080 11E0	CAN0 Message Slot 14 Standard ID0 (C0MSL14SID0)		CAN0 Message Slot 14 Standard ID1 (C0MSL14SID1)		13-86 13-88
H'0080 11E2	CAN0 Message Slot 14 Extended ID0 (C0MSL14EID0)		CAN0 Message Slot 14 Extended ID1 (C0MSL14EID1)		13-90 13-92
H'0080 11E4	CAN0 Message Slot 14 Extended ID2 (C0MSL14EID2)		CAN0 Message Slot 14 Data Length Register (C0MSL14DLC)		13-94 13-96
H'0080 11E6	CAN0 Message Slot 14 Data 0 (C0MSL14DT0)		CAN0 Message Slot 14 Data 1 (C0MSL14DT1)		13-98 13-100
H'0080 11E8	CAN0 Message Slot 14 Data 2 (C0MSL14DT2)		CAN0 Message Slot 14 Data 3 (C0MSL14DT3)		13-102 13-104
H'0080 11EA	CAN0 Message Slot 14 Data 4 (C0MSL14DT4)		CAN0 Message Slot 14 Data 5 (C0MSL14DT5)		13-106 13-108
H'0080 11EC	CAN0 Message Slot 14 Data 6 (C0MSL14DT6)		CAN0 Message Slot 14 Data 7 (C0MSL14DT7)		13-110 13-112
H'0080 11EE	CAN0 Message Slot 14 Timestamp (C0MSL14TSP)				13-114
H'0080 11F0	CAN0 Message Slot 15 Standard ID0 (C0MSL15SID0)		CAN0 Message Slot 15 Standard ID1 (C0MSL15SID1)		13-86 13-88
H'0080 11F2	CAN0 Message Slot 15 Extended ID0 (C0MSL15EID0)		CAN0 Message Slot 15 Extended ID1 (C0MSL15EID1)		13-90 13-92
H'0080 11F4	CAN0 Message Slot 15 Extended ID2 (C0MSL15EID2)		CAN0 Message Slot 15 Data Length Register (C0MSL15DLC)		13-94 13-96
H'0080 11F6	CAN0 Message Slot 15 Data 0 (C0MSL15DT0)		CAN0 Message Slot 15 Data 1 (C0MSL15DT1)		13-98 13-100
H'0080 11F8	CAN0 Message Slot 15 Data 2 (C0MSL15DT2)		CAN0 Message Slot 15 Data 3 (C0MSL15DT3)		13-102 13-104
H'0080 11FA	CAN0 Message Slot 15 Data 4 (C0MSL15DT4)		CAN0 Message Slot 15 Data 5 (C0MSL15DT5)		13-106 13-108
H'0080 11FC	CAN0 Message Slot 15 Data 6 (C0MSL15DT6)		CAN0 Message Slot 15 Data 7 (C0MSL15DT7)		13-110 13-112
H'0080 11FE	CAN0 Message Slot 15 Timestamp (C0MSL15TSP)				13-114
H'0080 1200	CAN0 Message Slot 16 Standard ID0 (C0MSL16SID0)		CAN0 Message Slot 16 Standard ID1 (C0MSL16SID1)		13-86 13-88
H'0080 1202	CAN0 Message Slot 16 Extended ID0 (C0MSL16EID0)		CAN0 Message Slot 16 Extended ID1 (C0MSL16EID1)		13-90 13-92
H'0080 1204	CAN0 Message Slot 16 Extended ID2 (C0MSL16EID2)		CAN0 Message Slot 16 Data Length Register (C0MSL16DLC)		13-94 13-96
H'0080 1206	CAN0 Message Slot 16 Data 0 (C0MSL16DT0)		CAN0 Message Slot 16 Data 1 (C0MSL16DT1)		13-98 13-100
H'0080 1208	CAN0 Message Slot 16 Data 2 (C0MSL16DT2)		CAN0 Message Slot 16 Data 3 (C0MSL16DT3)		13-102 13-104
H'0080 120A	CAN0 Message Slot 16 Data 4 (C0MSL16DT4)		CAN0 Message Slot 16 Data 5 (C0MSL16DT5)		13-106 13-108
H'0080 120C	CAN0 Message Slot 16 Data 6 (C0MSL16DT6)		CAN0 Message Slot 16 Data 7 (C0MSL16DT7)		13-110 13-112
H'0080 120E	CAN0 Message Slot 16 Timestamp (C0MSL16TSP)				13-114
H'0080 1210	CAN0 Message Slot 17 Standard ID0 (C0MSL17SID0)		CAN0 Message Slot 17 Standard ID1 (C0MSL17SID1)		13-86 13-88
H'0080 1212	CAN0 Message Slot 17 Extended ID0 (C0MSL17EID0)		CAN0 Message Slot 17 Extended ID1 (C0MSL17EID1)		13-90 13-92
H'0080 1214	CAN0 Message Slot 17 Extended ID2 (C0MSL17EID2)		CAN0 Message Slot 17 Data Length Register (C0MSL17DLC)		13-94 13-96
H'0080 1216	CAN0 Message Slot 17 Data 0 (C0MSL17DT0)		CAN0 Message Slot 17 Data 1 (C0MSL17DT1)		13-98 13-100
H'0080 1218	CAN0 Message Slot 17 Data 2 (C0MSL17DT2)		CAN0 Message Slot 17 Data 3 (C0MSL17DT3)		13-102 13-104
H'0080 121A	CAN0 Message Slot 17 Data 4 (C0MSL17DT4)		CAN0 Message Slot 17 Data 5 (C0MSL17DT5)		13-106 13-108
H'0080 121C	CAN0 Message Slot 17 Data 6 (C0MSL17DT6)		CAN0 Message Slot 17 Data 7 (C0MSL17DT7)		13-110 13-112
H'0080 121E	CAN0 Message Slot 17 Timestamp (C0MSL17TSP)				13-114

CAN Module Related Register Map (7/19)

Address	+0 address		+1 address		See pages
	b0	b7	b8	b15	
H'0080 1220	CAN0 Message Slot 18 Standard ID0 (C0MSL18SID0)		CAN0 Message Slot 18 Standard ID1 (C0MSL18SID1)		13-86 13-88
H'0080 1222	CAN0 Message Slot 18 Extended ID0 (C0MSL18EID0)		CAN0 Message Slot 18 Extended ID1 (C0MSL18EID1)		13-90 13-92
H'0080 1224	CAN0 Message Slot 18 Extended ID2 (C0MSL18EID2)		CAN0 Message Slot 18 Data Length Register (C0MSL18DLC)		13-94 13-96
H'0080 1226	CAN0 Message Slot 18 Data 0 (C0MSL18DT0)		CAN0 Message Slot 18 Data 1 (C0MSL18DT1)		13-98 13-100
H'0080 1228	CAN0 Message Slot 18 Data 2 (C0MSL18DT2)		CAN0 Message Slot 18 Data 3 (C0MSL18DT3)		13-102 13-104
H'0080 122A	CAN0 Message Slot 18 Data 4 (C0MSL18DT4)		CAN0 Message Slot 18 Data 5 (C0MSL18DT5)		13-106 13-108
H'0080 122C	CAN0 Message Slot 18 Data 6 (C0MSL18DT6)		CAN0 Message Slot 18 Data 7 (C0MSL18DT7)		13-110 13-112
H'0080 122E	CAN0 Message Slot 18 Timestamp (C0MSL18TSP)				13-114
H'0080 1230	CAN0 Message Slot 19 Standard ID0 (C0MSL19SID0)		CAN0 Message Slot 19 Standard ID1 (C0MSL19SID1)		13-86 13-88
H'0080 1232	CAN0 Message Slot 19 Extended ID0 (C0MSL19EID0)		CAN0 Message Slot 19 Extended ID1 (C0MSL19EID1)		13-90 13-92
H'0080 1234	CAN0 Message Slot 19 Extended ID2 (C0MSL19EID2)		CAN0 Message Slot 19 Data Length Register (C0MSL19DLC)		13-94 13-96
H'0080 1236	CAN0 Message Slot 19 Data 0 (C0MSL19DT0)		CAN0 Message Slot 19 Data 1 (C0MSL19DT1)		13-98 13-100
H'0080 1238	CAN0 Message Slot 19 Data 2 (C0MSL19DT2)		CAN0 Message Slot 19 Data 3 (C0MSL19DT3)		13-102 13-104
H'0080 123A	CAN0 Message Slot 19 Data 4 (C0MSL19DT4)		CAN0 Message Slot 19 Data 5 (C0MSL19DT5)		13-106 13-108
H'0080 123C	CAN0 Message Slot 19 Data 6 (C0MSL19DT6)		CAN0 Message Slot 19 Data 7 (C0MSL19DT7)		13-110 13-112
H'0080 123E	CAN0 Message Slot 19 Timestamp (C0MSL19TSP)				13-114
H'0080 1240	CAN0 Message Slot 20 Standard ID0 (C0MSL20SID0)		CAN0 Message Slot 20 Standard ID1 (C0MSL20SID1)		13-86 13-88
H'0080 1242	CAN0 Message Slot 20 Extended ID0 (C0MSL20EID0)		CAN0 Message Slot 20 Extended ID1 (C0MSL20EID1)		13-90 13-92
H'0080 1244	CAN0 Message Slot 20 Extended ID2 (C0MSL20EID2)		CAN0 Message Slot 20 Data Length Register (C0MSL20DLC)		13-94 13-96
H'0080 1246	CAN0 Message Slot 20 Data 0 (C0MSL20DT0)		CAN0 Message Slot 20 Data 1 (C0MSL20DT1)		13-98 13-100
H'0080 1248	CAN0 Message Slot 20 Data 2 (C0MSL20DT2)		CAN0 Message Slot 20 Data 3 (C0MSL20DT3)		13-102 13-104
H'0080 124A	CAN0 Message Slot 20 Data 4 (C0MSL20DT4)		CAN0 Message Slot 20 Data 5 (C0MSL20DT5)		13-106 13-108
H'0080 124C	CAN0 Message Slot 20 Data 6 (C0MSL20DT6)		CAN0 Message Slot 20 Data 7 (C0MSL20DT7)		13-110 13-112
H'0080 124E	CAN0 Message Slot 20 Timestamp (C0MSL20TSP)				13-114
H'0080 1250	CAN0 Message Slot 21 Standard ID0 (C0MSL21SID0)		CAN0 Message Slot 21 Standard ID1 (C0MSL21SID1)		13-86 13-88
H'0080 1252	CAN0 Message Slot 21 Extended ID0 (C0MSL21EID0)		CAN0 Message Slot 21 Extended ID1 (C0MSL21EID1)		13-90 13-92
H'0080 1254	CAN0 Message Slot 21 Extended ID2 (C0MSL21EID2)		CAN0 Message Slot 21 Data Length Register (C0MSL21DLC)		13-94 13-96
H'0080 1256	CAN0 Message Slot 21 Data 0 (C0MSL21DT0)		CAN0 Message Slot 21 Data 1 (C0MSL21DT1)		13-98 13-100
H'0080 1258	CAN0 Message Slot 21 Data 2 (C0MSL21DT2)		CAN0 Message Slot 21 Data 3 (C0MSL21DT3)		13-102 13-104
H'0080 125A	CAN0 Message Slot 21 Data 4 (C0MSL21DT4)		CAN0 Message Slot 21 Data 5 (C0MSL21DT5)		13-106 13-108
H'0080 125C	CAN0 Message Slot 21 Data 6 (C0MSL21DT6)		CAN0 Message Slot 21 Data 7 (C0MSL21DT7)		13-110 13-112
H'0080 125E	CAN0 Message Slot 21 Timestamp (C0MSL21TSP)				13-114

CAN Module Related Register Map (8/19)

Address	+0 address		+1 address		See pages
	b0	b7	b8	b15	
H'0080 1260	CAN0 Message Slot 22 Standard ID0 (C0MSL22SID0)		CAN0 Message Slot 22 Standard ID1 (C0MSL22SID1)		13-86 13-88
H'0080 1262	CAN0 Message Slot 22 Extended ID0 (C0MSL22EID0)		CAN0 Message Slot 22 Extended ID1 (C0MSL22EID1)		13-90 13-92
H'0080 1264	CAN0 Message Slot 22 Extended ID2 (C0MSL22EID2)		CAN0 Message Slot 22 Data Length Register (C0MSL22DLC)		13-94 13-96
H'0080 1266	CAN0 Message Slot 22 Data 0 (C0MSL22DT0)		CAN0 Message Slot 22 Data 1 (C0MSL22DT1)		13-98 13-100
H'0080 1268	CAN0 Message Slot 22 Data 2 (C0MSL22DT2)		CAN0 Message Slot 22 Data 3 (C0MSL22DT3)		13-102 13-104
H'0080 126A	CAN0 Message Slot 22 Data 4 (C0MSL22DT4)		CAN0 Message Slot 22 Data 5 (C0MSL22DT5)		13-106 13-108
H'0080 126C	CAN0 Message Slot 22 Data 6 (C0MSL22DT6)		CAN0 Message Slot 22 Data 7 (C0MSL22DT7)		13-110 13-112
H'0080 126E	CAN0 Message Slot 22 Timestamp (C0MSL22TSP)				13-114
H'0080 1270	CAN0 Message Slot 23 Standard ID0 (C0MSL23SID0)		CAN0 Message Slot 23 Standard ID1 (C0MSL23SID1)		13-86 13-88
H'0080 1272	CAN0 Message Slot 23 Extended ID0 (C0MSL23EID0)		CAN0 Message Slot 23 Extended ID1 (C0MSL23EID1)		13-90 13-92
H'0080 1274	CAN0 Message Slot 23 Extended ID2 (C0MSL23EID2)		CAN0 Message Slot 23 Data Length Register (C0MSL23DLC)		13-94 13-96
H'0080 1276	CAN0 Message Slot 23 Data 0 (C0MSL23DT0)		CAN0 Message Slot 23 Data 1 (C0MSL23DT1)		13-98 13-100
H'0080 1278	CAN0 Message Slot 23 Data 2 (C0MSL23DT2)		CAN0 Message Slot 23 Data 3 (C0MSL23DT3)		13-102 13-104
H'0080 127A	CAN0 Message Slot 23 Data 4 (C0MSL23DT4)		CAN0 Message Slot 23 Data 5 (C0MSL23DT5)		13-106 13-108
H'0080 127C	CAN0 Message Slot 23 Data 6 (C0MSL23DT6)		CAN0 Message Slot 23 Data 7 (C0MSL23DT7)		13-110 13-112
H'0080 127E	CAN0 Message Slot 23 Timestamp (C0MSL23TSP)				13-114
H'0080 1280	CAN0 Message Slot 24 Standard ID0 (C0MSL24SID0)		CAN0 Message Slot 24 Standard ID1 (C0MSL24SID1)		13-86 13-88
H'0080 1282	CAN0 Message Slot 24 Extended ID0 (C0MSL24EID0)		CAN0 Message Slot 24 Extended ID1 (C0MSL24EID1)		13-90 13-92
H'0080 1284	CAN0 Message Slot 24 Extended ID2 (C0MSL24EID2)		CAN0 Message Slot 24 Data Length Register (C0MSL24DLC)		13-94 13-96
H'0080 1286	CAN0 Message Slot 24 Data 0 (C0MSL24DT0)		CAN0 Message Slot 24 Data 1 (C0MSL24DT1)		13-98 13-100
H'0080 1288	CAN0 Message Slot 24 Data 2 (C0MSL24DT2)		CAN0 Message Slot 24 Data 3 (C0MSL24DT3)		13-102 13-104
H'0080 128A	CAN0 Message Slot 24 Data 4 (C0MSL24DT4)		CAN0 Message Slot 24 Data 5 (C0MSL24DT5)		13-106 13-108
H'0080 128C	CAN0 Message Slot 24 Data 6 (C0MSL24DT6)		CAN0 Message Slot 24 Data 7 (C0MSL24DT7)		13-110 13-112
H'0080 128E	CAN0 Message Slot 24 Timestamp (C0MSL24TSP)				13-114
H'0080 1290	CAN0 Message Slot 25 Standard ID0 (C0MSL25SID0)		CAN0 Message Slot 25 Standard ID1 (C0MSL25SID1)		13-86 13-88
H'0080 1292	CAN0 Message Slot 25 Extended ID0 (C0MSL25EID0)		CAN0 Message Slot 25 Extended ID1 (C0MSL25EID1)		13-90 13-92
H'0080 1294	CAN0 Message Slot 25 Extended ID2 (C0MSL25EID2)		CAN0 Message Slot 25 Data Length Register (C0MSL25DLC)		13-94 13-96
H'0080 1296	CAN0 Message Slot 25 Data 0 (C0MSL25DT0)		CAN0 Message Slot 25 Data 1 (C0MSL25DT1)		13-98 13-100
H'0080 1298	CAN0 Message Slot 25 Data 2 (C0MSL25DT2)		CAN0 Message Slot 25 Data 3 (C0MSL25DT3)		13-102 13-104
H'0080 129A	CAN0 Message Slot 25 Data 4 (C0MSL25DT4)		CAN0 Message Slot 25 Data 5 (C0MSL25DT5)		13-106 13-108
H'0080 129C	CAN0 Message Slot 25 Data 6 (C0MSL25DT6)		CAN0 Message Slot 25 Data 7 (C0MSL25DT7)		13-110 13-112
H'0080 129E	CAN0 Message Slot 25 Timestamp (C0MSL25TSP)				13-114



CAN Module Related Register Map (9/19)

Address	+0 address		+1 address		See pages
	b0	b7	b8	b15	
H'0080 12A0	CAN0 Message Slot 26 Standard ID0 (C0MSL26SID0)		CAN0 Message Slot 26 Standard ID1 (C0MSL26SID1)		13-86 13-88
H'0080 12A2	CAN0 Message Slot 26 Extended ID0 (C0MSL26EID0)		CAN0 Message Slot 26 Extended ID1 (C0MSL26EID1)		13-90 13-92
H'0080 12A4	CAN0 Message Slot 26 Extended ID2 (C0MSL26EID2)		CAN0 Message Slot 26 Data Length Register (C0MSL26DLC)		13-94 13-96
H'0080 12A6	CAN0 Message Slot 26 Data 0 (C0MSL26DT0)		CAN0 Message Slot 26 Data 1 (C0MSL26DT1)		13-98 13-100
H'0080 12A8	CAN0 Message Slot 26 Data 2 (C0MSL26DT2)		CAN0 Message Slot 26 Data 3 (C0MSL26DT3)		13-102 13-104
H'0080 12AA	CAN0 Message Slot 26 Data 4 (C0MSL26DT4)		CAN0 Message Slot 26 Data 5 (C0MSL26DT5)		13-106 13-108
H'0080 12AC	CAN0 Message Slot 26 Data 6 (C0MSL26DT6)		CAN0 Message Slot 26 Data 7 (C0MSL26DT7)		13-110 13-112
H'0080 12AE	CAN0 Message Slot 26 Timestamp (C0MSL26TSP)				13-114
H'0080 12B0	CAN0 Message Slot 27 Standard ID0 (C0MSL27SID0)		CAN0 Message Slot 27 Standard ID1 (C0MSL27SID1)		13-86 13-88
H'0080 12B2	CAN0 Message Slot 27 Extended ID0 (C0MSL27EID0)		CAN0 Message Slot 27 Extended ID1 (C0MSL27EID1)		13-90 13-92
H'0080 12B4	CAN0 Message Slot 27 Extended ID2 (C0MSL27EID2)		CAN0 Message Slot 27 Data Length Register (C0MSL27DLC)		13-94 13-96
H'0080 12B6	CAN0 Message Slot 27 Data 0 (C0MSL27DT0)		CAN0 Message Slot 27 Data 1 (C0MSL27DT1)		13-98 13-100
H'0080 12B8	CAN0 Message Slot 27 Data 2 (C0MSL27DT2)		CAN0 Message Slot 27 Data 3 (C0MSL27DT3)		13-102 13-104
H'0080 12BA	CAN0 Message Slot 27 Data 4 (C0MSL27DT4)		CAN0 Message Slot 27 Data 5 (C0MSL27DT5)		13-106 13-108
H'0080 12BC	CAN0 Message Slot 27 Data 6 (C0MSL27DT6)		CAN0 Message Slot 27 Data 7 (C0MSL27DT7)		13-110 13-112
H'0080 12BE	CAN0 Message Slot 27 Timestamp (C0MSL27TSP)				13-114
H'0080 12C0	CAN0 Message Slot 28 Standard ID0 (C0MSL28SID0)		CAN0 Message Slot 28 Standard ID1 (C0MSL28SID1)		13-86 13-88
H'0080 12C2	CAN0 Message Slot 28 Extended ID0 (C0MSL28EID0)		CAN0 Message Slot 28 Extended ID1 (C0MSL28EID1)		13-90 13-92
H'0080 12C4	CAN0 Message Slot 28 Extended ID2 (C0MSL28EID2)		CAN0 Message Slot 28 Data Length Register (C0MSL28DLC)		13-94 13-96
H'0080 12C6	CAN0 Message Slot 28 Data 0 (C0MSL28DT0)		CAN0 Message Slot 28 Data 1 (C0MSL28DT1)		13-98 13-100
H'0080 12C8	CAN0 Message Slot 28 Data 2 (C0MSL28DT2)		CAN0 Message Slot 28 Data 3 (C0MSL28DT3)		13-102 13-104
H'0080 12CA	CAN0 Message Slot 28 Data 4 (C0MSL28DT4)		CAN0 Message Slot 28 Data 5 (C0MSL28DT5)		13-106 13-108
H'0080 12CC	CAN0 Message Slot 28 Data 6 (C0MSL28DT6)		CAN0 Message Slot 28 Data 7 (C0MSL28DT7)		13-110 13-112
H'0080 12CE	CAN0 Message Slot 28 Timestamp (C0MSL28TSP)				13-114
H'0080 12D0	CAN0 Message Slot 29 Standard ID0 (C0MSL29SID0)		CAN0 Message Slot 29 Standard ID1 (C0MSL29SID1)		13-86 13-88
H'0080 12D2	CAN0 Message Slot 29 Extended ID0 (C0MSL29EID0)		CAN0 Message Slot 29 Extended ID1 (C0MSL29EID1)		13-90 13-92
H'0080 12D4	CAN0 Message Slot 29 Extended ID2 (C0MSL29EID2)		CAN0 Message Slot 29 Data Length Register (C0MSL29DLC)		13-94 13-96
H'0080 12D6	CAN0 Message Slot 29 Data 0 (C0MSL29DT0)		CAN0 Message Slot 29 Data 1 (C0MSL29DT1)		13-98 13-100
H'0080 12D8	CAN0 Message Slot 29 Data 2 (C0MSL29DT2)		CAN0 Message Slot 29 Data 3 (C0MSL29DT3)		13-102 13-104
H'0080 12DA	CAN0 Message Slot 29 Data 4 (C0MSL29DT4)		CAN0 Message Slot 29 Data 5 (C0MSL29DT5)		13-106 13-108
H'0080 12DC	CAN0 Message Slot 29 Data 6 (C0MSL29DT6)		CAN0 Message Slot 29 Data 7 (C0MSL29DT7)		13-110 13-112
H'0080 12DE	CAN0 Message Slot 29 Timestamp (C0MSL29TSP)				13-114

CAN Module Related Register Map (10/19)

Address	+0 address		+1 address		See pages
	b0	b7	b8	b15	
H'0080 12E0	CAN0 Message Slot 30 Standard ID0 (C0MSL30SID0)		CAN0 Message Slot 30 Standard ID1 (C0MSL30SID1)		13-86 13-88
H'0080 12E2	CAN0 Message Slot 30 Extended ID0 (C0MSL30EID0)		CAN0 Message Slot 30 Extended ID1 (C0MSL30EID1)		13-90 13-92
H'0080 12E4	CAN0 Message Slot 30 Extended ID2 (C0MSL30EID2)		CAN0 Message Slot 30 Data Length Register (C0MSL30DLC)		13-94 13-96
H'0080 12E6	CAN0 Message Slot 30 Data 0 (C0MSL30DT0)		CAN0 Message Slot 30 Data 1 (C0MSL30DT1)		13-98 13-100
H'0080 12E8	CAN0 Message Slot 30 Data 2 (C0MSL30DT2)		CAN0 Message Slot 30 Data 3 (C0MSL30DT3)		13-102 13-104
H'0080 12EA	CAN0 Message Slot 30 Data 4 (C0MSL30DT4)		CAN0 Message Slot 30 Data 5 (C0MSL30DT5)		13-106 13-108
H'0080 12EC	CAN0 Message Slot 30 Data 6 (C0MSL30DT6)		CAN0 Message Slot 30 Data 7 (C0MSL30DT7)		13-110 13-112
H'0080 12EE	CAN0 Message Slot 30 Timestamp (C0MSL30TSP)				13-114
H'0080 12F0	CAN0 Message Slot 31 Standard ID0 (C0MSL31SID0)		CAN0 Message Slot 31 Standard ID1 (C0MSL31SID1)		13-86 13-88
H'0080 12F2	CAN0 Message Slot 31 Extended ID0 (C0MSL31EID0)		CAN0 Message Slot 31 Extended ID1 (C0MSL31EID1)		13-90 13-92
H'0080 12F4	CAN0 Message Slot 31 Extended ID2 (C0MSL31EID2)		CAN0 Message Slot 31 Data Length Register (C0MSL31DLC)		13-94 13-96
H'0080 12F6	CAN0 Message Slot 31 Data 0 (C0MSL31DT0)		CAN0 Message Slot 31 Data 1 (C0MSL31DT1)		13-98 13-100
H'0080 12F8	CAN0 Message Slot 31 Data 2 (C0MSL31DT2)		CAN0 Message Slot 31 Data 3 (C0MSL31DT3)		13-102 13-104
H'0080 12FA	CAN0 Message Slot 31 Data 4 (C0MSL31DT4)		CAN0 Message Slot 31 Data 5 (C0MSL31DT5)		13-106 13-108
H'0080 12FC	CAN0 Message Slot 31 Data 6 (C0MSL31DT6)		CAN0 Message Slot 31 Data 7 (C0MSL31DT7)		13-110 13-112
H'0080 12FE	CAN0 Message Slot 31 Timestamp (C0MSL31TSP)				13-114
	(Use inhibited area)				
H'0080 1400	CAN1 Control Register (CAN1CNT)				13-26
H'0080 1402	CAN1 Status Register (CAN1STAT)				13-29
H'0080 1404	(Use inhibited area)				
H'0080 1406	CAN1 Configuration Register (CAN1CONF)				13-32
H'0080 1408	CAN1 Timestamp Count Register (CAN1TSTMP)				13-35
H'0080 140A	CAN1 Receive Error Count Register (CAN1REC)		CAN1 Transmit Error Count Register (CAN1TEC)		13-36
H'0080 140C	CAN1 Slot Interrupt Request Status Register (CAN1SLISTW)				(Upper) 13-40
H'0080 140E	----- (Lower) (CAN1SLISTL)				
H'0080 1410	CAN1 Slot Interrupt Request Mask Register (CAN1SLIMKW)				(Upper) 13-42
H'0080 1412	----- (Lower) (CAN1SLIMKL)				
H'0080 1414	CAN1 Error Interrupt Request Status Register (CAN1ERIST)		CAN1 Error Interrupt Request Mask Register (CAN1ERIMK)		13-43 13-44
H'0080 1416	CAN1 Baud Rate Prescaler (CAN1BRP)		CAN1 Cause of Error Register (CAN1EF)		13-37 13-67
H'0080 1418	CAN1 Mode Register (CAN1MOD)		CAN1 DMA Transfer Request Select Register (CAN1DMARQ)		13-69 13-70
H'0080 141A	CAN1 Message Slot Number Register (CAN1MSN)		CAN1 Clock Select Register (CAN1CKSEL)		13-71 13-72
H'0080 141C	CAN1 Frame Format Select Register (CAN1FFSW)				(Upper) 13-74
H'0080 141E	----- (Lower) (CAN1FFSL)				
H'0080 1420	CAN1 Global Mask Register A Standard ID0 (C1GMSKAS0)		CAN1 Global Mask Register A Standard ID1 (C1GMSKAS1)		13-76
H'0080 1422	CAN1 Global Mask Register A Extended ID0 (C1GMSKAE0)		CAN1 Global Mask Register A Extended ID1 (C1GMSKAE1)		13-77

CAN Module Related Register Map (11/19)

Address	+0 address		+1 address		See pages
	b0	b7	b8	b15	
H'0080 1424	CAN1 Global Mask Register A Extended ID2 (C1GMSKAE2)		(Use inhibited area)		13-78
H'0080 1426	(Use inhibited area)				
H'0080 1428	CAN1 Global Mask Register B Standard ID0 (C1GMSKBS0)		CAN1 Global Mask Register B Standard ID1 (C1GMSKBS1)		13-76
H'0080 142A	CAN1 Global Mask Register B Extended ID0 (C1GMSKBE0)		CAN1 Global Mask Register B Extended ID1 (C1GMSKBE1)		13-77
H'0080 142C	CAN1 Global Mask Register B Extended ID2 (C1GMSKBE2)		(Use inhibited area)		13-78
H'0080 142E	(Use inhibited area)				
H'0080 1430	CAN1 Local Mask Register A Standard ID0 (C1LMSKAS0)		CAN1 Local Mask Register A Standard ID1 (C1LMSKAS1)		13-76
H'0080 1432	CAN1 Local Mask Register A Extended ID0 (C1LMSKAE0)		CAN1 Local Mask Register A Extended ID1 (C1LMSKAE1)		13-77
H'0080 1434	CAN1 Local Mask Register A Extended ID2 (C1LMSKAE2)		(Use inhibited area)		13-78
H'0080 1436	(Use inhibited area)				
H'0080 1438	CAN1 Local Mask Register B Standard ID0 (C1LMSKBS0)		CAN1 Local Mask Register B Standard ID1 (C1LMSKBS1)		13-76
H'0080 143A	CAN1 Local Mask Register B Extended ID0 (C1LMSKBE0)		CAN1 Local Mask Register B Extended ID1 (C1LMSKBE1)		13-77
H'0080 143C	CAN1 Local Mask Register B Extended ID2 (C1LMSKBE2)		(Use inhibited area)		13-78
H'0080 143E	(Use inhibited area)				
H'0080 1440	CAN1 Single-Shot Mode Control Register (CAN1SSMODEW)		(Upper) (CAN1SSMODE)		13-80
H'0080 1442	-----		(Lower) (CAN1SSMODEL)		
H'0080 1444	CAN1 Single-Shot Interrupt Request Status Register (CAN1SSISTW)		(Upper) (CAN1SSIST)		13-45
H'0080 1446	-----		(Lower) (CAN1SSISTL)		
H'0080 1448	CAN1 Single-Shot Interrupt Request Mask Register (CAN1SSIMKW)		(Upper) (CAN1SSIMK)		13-47
H'0080 144A	-----		(Lower) (CAN1SSIMKL)		
	(Use inhibited area)				
H'0080 1450	CAN1 Message Slot 0 Control Register (C1MSL0CNT)		CAN1 Message Slot 1 Control Register (C1MSL1CNT)		13-82
H'0080 1452	CAN1 Message Slot 2 Control Register (C1MSL2CNT)		CAN1 Message Slot 3 Control Register (C1MSL3CNT)		13-82
H'0080 1454	CAN1 Message Slot 4 Control Register (C1MSL4CNT)		CAN1 Message Slot 5 Control Register (C1MSL5CNT)		13-82
H'0080 1456	CAN1 Message Slot 6 Control Register (C1MSL6CNT)		CAN1 Message Slot 7 Control Register (C1MSL7CNT)		13-82
H'0080 1458	CAN1 Message Slot 8 Control Register (C1MSL8CNT)		CAN1 Message Slot 9 Control Register (C1MSL9CNT)		13-82
H'0080 145A	CAN1 Message Slot 10 Control Register (C1MSL10CNT)		CAN1 Message Slot 11 Control Register (C1MSL11CNT)		13-82
H'0080 145C	CAN1 Message Slot 12 Control Register (C1MSL12CNT)		CAN1 Message Slot 13 Control Register (C1MSL13CNT)		13-82
H'0080 145E	CAN1 Message Slot 14 Control Register (C1MSL14CNT)		CAN1 Message Slot 15 Control Register (C1MSL15CNT)		13-82
H'0080 1460	CAN1 Message Slot 16 Control Register (C1MSL16CNT)		CAN1 Message Slot 17 Control Register (C1MSL17CNT)		13-83
H'0080 1462	CAN1 Message Slot 18 Control Register (C1MSL18CNT)		CAN1 Message Slot 19 Control Register (C1MSL19CNT)		13-83
H'0080 1464	CAN1 Message Slot 20 Control Register (C1MSL20CNT)		CAN1 Message Slot 21 Control Register (C1MSL21CNT)		13-83
H'0080 1466	CAN1 Message Slot 22 Control Register (C1MSL22CNT)		CAN1 Message Slot 23 Control Register (C1MSL23CNT)		13-83
H'0080 1468	CAN1 Message Slot 24 Control Register (C1MSL24CNT)		CAN1 Message Slot 25 Control Register (C1MSL25CNT)		13-83



CAN Module Related Register Map (12/19)

Address	+0 address		+1 address		See pages
	b0	b7	b8	b15	
H'0080 146A	CAN1 Message Slot 26 Control Register (C1MSL26CNT)		CAN1 Message Slot 27 Control Register (C1MSL27CNT)		13-83
H'0080 146C	CAN1 Message Slot 28 Control Register (C1MSL28CNT)		CAN1 Message Slot 29 Control Register (C1MSL29CNT)		13-83
H'0080 146E	CAN1 Message Slot 30 Control Register (C1MSL30CNT)		CAN1 Message Slot 31 Control Register (C1MSL31CNT)		13-83
	(Use inhibited area)				
H'0080 1500	CAN1 Message Slot 0 Standard ID0 (C1MSL0SID0)		CAN1 Message Slot 0 Standard ID1 (C1MSL0SID1)		13-86 13-88
H'0080 1502	CAN1 Message Slot 0 Extended ID0 (C1MSL0EID0)		CAN1 Message Slot 0 Extended ID1 (C1MSL0EID1)		13-90 13-92
H'0080 1504	CAN1 Message Slot 0 Extended ID2 (C1MSL0EID2)		CAN1 Message Slot 0 Data Length Register (C1MSL0DLC)		13-94 13-96
H'0080 1506	CAN1 Message Slot 0 Data 0 (C1MSL0DT0)		CAN1 Message Slot 0 Data 1 (C1MSL0DT1)		13-98 13-100
H'0080 1508	CAN1 Message Slot 0 Data 2 (C1MSL0DT2)		CAN1 Message Slot 0 Data 3 (C1MSL0DT3)		13-102 13-104
H'0080 150A	CAN1 Message Slot 0 Data 4 (C1MSL0DT4)		CAN1 Message Slot 0 Data 5 (C1MSL0DT5)		13-106 13-108
H'0080 150C	CAN1 Message Slot 0 Data 6 (C1MSL0DT6)		CAN1 Message Slot 0 Data 7 (C1MSL0DT7)		13-110 13-112
H'0080 150E	CAN1 Message Slot 0 Timestamp (C1MSL0TSP)				13-114
H'0080 1510	CAN1 Message Slot 1 Standard ID0 (C1MSL1SID0)		CAN1 Message Slot 1 Standard ID1 (C1MSL1SID1)		13-86 13-88
H'0080 1512	CAN1 Message Slot 1 Extended ID0 (C1MSL1EID0)		CAN1 Message Slot 1 Extended ID1 (C1MSL1EID1)		13-90 13-92
H'0080 1514	CAN1 Message Slot 1 Extended ID2 (C1MSL1EID2)		CAN1 Message Slot 1 Data Length Register (C1MSL1DLC)		13-94 13-96
H'0080 1516	CAN1 Message Slot 1 Data 0 (C1MSL1DT0)		CAN1 Message Slot 1 Data 1 (C1MSL1DT1)		13-98 13-100
H'0080 1518	CAN1 Message Slot 1 Data 2 (C1MSL1DT2)		CAN1 Message Slot 1 Data 3 (C1MSL1DT3)		13-102 13-104
H'0080 151A	CAN1 Message Slot 1 Data 4 (C1MSL1DT4)		CAN1 Message Slot 1 Data 5 (C1MSL1DT5)		13-106 13-108
H'0080 151C	CAN1 Message Slot 1 Data 6 (C1MSL1DT6)		CAN1 Message Slot 1 Data 7 (C1MSL1DT7)		13-110 13-112
H'0080 151E	CAN1 Message Slot 1 Timestamp (C1MSL1TSP)				13-114
H'0080 1520	CAN1 Message Slot 2 Standard ID0 (C1MSL2SID0)		CAN1 Message Slot 2 Standard ID1 (C1MSL2SID1)		13-86 13-88
H'0080 1522	CAN1 Message Slot 2 Extended ID0 (C1MSL2EID0)		CAN1 Message Slot 2 Extended ID1 (C1MSL2EID1)		13-90 13-92
H'0080 1524	CAN1 Message Slot 2 Extended ID2 (C1MSL2EID2)		CAN1 Message Slot 2 Data Length Register (C1MSL2DLC)		13-94 13-96
H'0080 1526	CAN1 Message Slot 2 Data 0 (C1MSL2DT0)		CAN1 Message Slot 2 Data 1 (C1MSL2DT1)		13-98 13-100
H'0080 1528	CAN1 Message Slot 2 Data 2 (C1MSL2DT2)		CAN1 Message Slot 2 Data 3 (C1MSL2DT3)		13-102 13-104
H'0080 152A	CAN1 Message Slot 2 Data 4 (C1MSL2DT4)		CAN1 Message Slot 2 Data 5 (C1MSL2DT5)		13-106 13-108
H'0080 152C	CAN1 Message Slot 2 Data 6 (C1MSL2DT6)		CAN1 Message Slot 2 Data 7 (C1MSL2DT7)		13-110 13-112
H'0080 152E	CAN1 Message Slot 2 Timestamp (C1MSL2TSP)				13-114
H'0080 1530	CAN1 Message Slot 3 Standard ID0 (C1MSL3SID0)		CAN1 Message Slot 3 Standard ID1 (C1MSL3SID1)		13-86 13-88
H'0080 1532	CAN1 Message Slot 3 Extended ID0 (C1MSL3EID0)		CAN1 Message Slot 3 Extended ID1 (C1MSL3EID1)		13-90 13-92
H'0080 1534	CAN1 Message Slot 3 Extended ID2 (C1MSL3EID2)		CAN1 Message Slot 3 Data Length Register (C1MSL3DLC)		13-94 13-96
H'0080 1536	CAN1 Message Slot 3 Data 0 (C1MSL3DT0)		CAN1 Message Slot 3 Data 1 (C1MSL3DT1)		13-98 13-100
H'0080 1538	CAN1 Message Slot 3 Data 2 (C1MSL3DT2)		CAN1 Message Slot 3 Data 3 (C1MSL3DT3)		13-102 13-104
H'0080 153A	CAN1 Message Slot 3 Data 4 (C1MSL3DT4)		CAN1 Message Slot 3 Data 5 (C1MSL3DT5)		13-106 13-108
H'0080 153C	CAN1 Message Slot 3 Data 6 (C1MSL3DT6)		CAN1 Message Slot 3 Data 7 (C1MSL3DT7)		13-110 13-112

CAN Module Related Register Map (13/19)

Address	+0 address		+1 address		See pages
	b0	b7	b8	b15	
H'0080 153E	CAN1 Message Slot 3 Timestamp (C1MSL3TSP)				13-114
H'0080 1540	CAN1 Message Slot 4 Standard ID0 (C1MSL4SID0)		CAN1 Message Slot 4 Standard ID1 (C1MSL4SID1)		13-86 13-88
H'0080 1542	CAN1 Message Slot 4 Extended ID0 (C1MSL4EID0)		CAN1 Message Slot 4 Extended ID1 (C1MSL4EID1)		13-90 13-92
H'0080 1544	CAN1 Message Slot 4 Extended ID2 (C1MSL4EID2)		CAN1 Message Slot 4 Data Length Register (C1MSL4DLC)		13-94 13-96
H'0080 1546	CAN1 Message Slot 4 Data 0 (C1MSL4DT0)		CAN1 Message Slot 4 Data 1 (C1MSL4DT1)		13-98 13-100
H'0080 1548	CAN1 Message Slot 4 Data 2 (C1MSL4DT2)		CAN1 Message Slot 4 Data 3 (C1MSL4DT3)		13-102 13-104
H'0080 154A	CAN1 Message Slot 4 Data 4 (C1MSL4DT4)		CAN1 Message Slot 4 Data 5 (C1MSL4DT5)		13-106 13-108
H'0080 154C	CAN1 Message Slot 4 Data 6 (C1MSL4DT6)		CAN1 Message Slot 4 Data 7 (C1MSL4DT7)		13-110 13-112
H'0080 154E	CAN1 Message Slot 4 Timestamp (C1MSL4TSP)				13-114
H'0080 1550	CAN1 Message Slot 5 Standard ID0 (C1MSL5SID0)		CAN1 Message Slot 5 Standard ID1 (C1MSL5SID1)		13-86 13-88
H'0080 1552	CAN1 Message Slot 5 Extended ID0 (C1MSL5EID0)		CAN1 Message Slot 5 Extended ID1 (C1MSL5EID1)		13-90 13-92
H'0080 1554	CAN1 Message Slot 5 Extended ID2 (C1MSL5EID2)		CAN1 Message Slot 5 Data Length Register (C1MSL5DLC)		13-94 13-96
H'0080 1556	CAN1 Message Slot 5 Data 0 (C1MSL5DT0)		CAN1 Message Slot 5 Data 1 (C1MSL5DT1)		13-98 13-100
H'0080 1558	CAN1 Message Slot 5 Data 2 (C1MSL5DT2)		CAN1 Message Slot 5 Data 3 (C1MSL5DT3)		13-102 13-104
H'0080 155A	CAN1 Message Slot 5 Data 4 (C1MSL5DT4)		CAN1 Message Slot 5 Data 5 (C1MSL5DT5)		13-106 13-108
H'0080 155C	CAN1 Message Slot 5 Data 6 (C1MSL5DT6)		CAN1 Message Slot 5 Data 7 (C1MSL5DT7)		13-110 13-112
H'0080 155E	CAN1 Message Slot 5 Timestamp (C1MSL5TSP)				13-114
H'0080 1560	CAN1 Message Slot 6 Standard ID0 (C1MSL6SID0)		CAN1 Message Slot 6 Standard ID1 (C1MSL6SID1)		13-86 13-88
H'0080 1562	CAN1 Message Slot 6 Extended ID0 (C1MSL6EID0)		CAN1 Message Slot 6 Extended ID1 (C1MSL6EID1)		13-90 13-92
H'0080 1564	CAN1 Message Slot 6 Extended ID2 (C1MSL6EID2)		CAN1 Message Slot 6 Data Length Register (C1MSL6DLC)		13-94 13-96
H'0080 1566	CAN1 Message Slot 6 Data 0 (C1MSL6DT0)		CAN1 Message Slot 6 Data 1 (C1MSL6DT1)		13-98 13-100
H'0080 1568	CAN1 Message Slot 6 Data 2 (C1MSL6DT2)		CAN1 Message Slot 6 Data 3 (C1MSL6DT3)		13-102 13-104
H'0080 156A	CAN1 Message Slot 6 Data 4 (C1MSL6DT4)		CAN1 Message Slot 6 Data 5 (C1MSL6DT5)		13-106 13-108
H'0080 156C	CAN1 Message Slot 6 Data 6 (C1MSL6DT6)		CAN1 Message Slot 6 Data 7 (C1MSL6DT7)		13-110 13-112
H'0080 156E	CAN1 Message Slot 6 Timestamp (C1MSL6TSP)				13-114
H'0080 1570	CAN1 Message Slot 7 Standard ID0 (C1MSL7SID0)		CAN1 Message Slot 7 Standard ID1 (C1MSL7SID1)		13-86 13-88
H'0080 1572	CAN1 Message Slot 7 Extended ID0 (C1MSL7EID0)		CAN1 Message Slot 7 Extended ID1 (C1MSL7EID1)		13-90 13-92
H'0080 1574	CAN1 Message Slot 7 Extended ID2 (C1MSL7EID2)		CAN1 Message Slot 7 Data Length Register (C1MSL7DLC)		13-94 13-96
H'0080 1576	CAN1 Message Slot 7 Data 0 (C1MSL7DT0)		CAN1 Message Slot 7 Data 1 (C1MSL7DT1)		13-98 13-100
H'0080 1578	CAN1 Message Slot 7 Data 2 (C1MSL7DT2)		CAN1 Message Slot 7 Data 3 (C1MSL7DT3)		13-102 13-104
H'0080 157A	CAN1 Message Slot 7 Data 4 (C1MSL7DT4)		CAN1 Message Slot 7 Data 5 (C1MSL7DT5)		13-106 13-108
H'0080 157C	CAN1 Message Slot 7 Data 6 (C1MSL7DT6)		CAN1 Message Slot 7 Data 7 (C1MSL7DT7)		13-110 13-112
H'0080 157E	CAN1 Message Slot 7 Timestamp (C1MSL7TSP)				13-114

CAN Module Related Register Map (14/19)

Address	+0 address		+1 address		See pages
	b0	b7	b8	b15	
H'0080 1580	CAN1 Message Slot 8 Standard ID0 (C1MSL8SID0)		CAN1 Message Slot 8 Standard ID1 (C1MSL8SID1)		13-86 13-88
H'0080 1582	CAN1 Message Slot 8 Extended ID0 (C1MSL8EID0)		CAN1 Message Slot 8 Extended ID1 (C1MSL8EID1)		13-90 13-92
H'0080 1584	CAN1 Message Slot 8 Extended ID2 (C1MSL8EID2)		CAN1 Message Slot 8 Data Length Register (C1MSL8DLC)		13-94 13-96
H'0080 1586	CAN1 Message Slot 8 Data 0 (C1MSL8DT0)		CAN1 Message Slot 8 Data 1 (C1MSL8DT1)		13-98 13-100
H'0080 1588	CAN1 Message Slot 8 Data 2 (C1MSL8DT2)		CAN1 Message Slot 8 Data 3 (C1MSL8DT3)		13-102 13-104
H'0080 158A	CAN1 Message Slot 8 Data 4 (C1MSL8DT4)		CAN1 Message Slot 8 Data 5 (C1MSL8DT5)		13-106 13-108
H'0080 158C	CAN1 Message Slot 8 Data 6 (C1MSL8DT6)		CAN1 Message Slot 8 Data 7 (C1MSL8DT7)		13-110 13-112
H'0080 158E	CAN1 Message Slot 8 Timestamp (C1MSL8TSP)				13-114
H'0080 1590	CAN1 Message Slot 9 Standard ID0 (C1MSL9SID0)		CAN1 Message Slot 9 Standard ID1 (C1MSL9SID1)		13-86 13-88
H'0080 1592	CAN1 Message Slot 9 Extended ID0 (C1MSL9EID0)		CAN1 Message Slot 9 Extended ID1 (C1MSL9EID1)		13-90 13-92
H'0080 1594	CAN1 Message Slot 9 Extended ID2 (C1MSL9EID2)		CAN1 Message Slot 9 Data Length Register (C1MSL9DLC)		13-94 13-96
H'0080 1596	CAN1 Message Slot 9 Data 0 (C1MSL9DT0)		CAN1 Message Slot 9 Data 1 (C1MSL9DT1)		13-98 13-100
H'0080 1598	CAN1 Message Slot 9 Data 2 (C1MSL9DT2)		CAN1 Message Slot 9 Data 3 (C1MSL9DT3)		13-102 13-104
H'0080 159A	CAN1 Message Slot 9 Data 4 (C1MSL9DT4)		CAN1 Message Slot 9 Data 5 (C1MSL9DT5)		13-106 13-108
H'0080 159C	CAN1 Message Slot 9 Data 6 (C1MSL9DT6)		CAN1 Message Slot 9 Data 7 (C1MSL9DT7)		13-110 13-112
H'0080 159E	CAN1 Message Slot 9 Timestamp (C1MSL9TSP)				13-114
H'0080 15A0	CAN1 Message Slot 10 Standard ID0 (C1MSL10SID0)		CAN1 Message Slot 10 Standard ID1 (C1MSL10SID1)		13-86 13-88
H'0080 15A2	CAN1 Message Slot 10 Extended ID0 (C1MSL10EID0)		CAN1 Message Slot 10 Extended ID1 (C1MSL10EID1)		13-90 13-92
H'0080 15A4	CAN1 Message Slot 10 Extended ID2 (C1MSL10EID2)		CAN1 Message Slot 10 Data Length Register (C1MSL10DLC)		13-94 13-96
H'0080 15A6	CAN1 Message Slot 10 Data 0 (C1MSL10DT0)		CAN1 Message Slot 10 Data 1 (C1MSL10DT1)		13-98 13-100
H'0080 15A8	CAN1 Message Slot 10 Data 2 (C1MSL10DT2)		CAN1 Message Slot 10 Data 3 (C1MSL10DT3)		13-102 13-104
H'0080 15AA	CAN1 Message Slot 10 Data 4 (C1MSL10DT4)		CAN1 Message Slot 10 Data 5 (C1MSL10DT5)		13-106 13-108
H'0080 15AC	CAN1 Message Slot 10 Data 6 (C1MSL10DT6)		CAN1 Message Slot 10 Data 7 (C1MSL10DT7)		13-110 13-112
H'0080 15AE	CAN1 Message Slot 10 Timestamp (C1MSL10TSP)				13-114
H'0080 15B0	CAN1 Message Slot 11 Standard ID0 (C1MSL11SID0)		CAN1 Message Slot 11 Standard ID1 (C1MSL11SID1)		13-86 13-88
H'0080 15B2	CAN1 Message Slot 11 Extended ID0 (C1MSL11EID0)		CAN1 Message Slot 11 Extended ID1 (C1MSL11EID1)		13-90 13-92
H'0080 15B4	CAN1 Message Slot 11 Extended ID2 (C1MSL11EID2)		CAN1 Message Slot 11 Data Length Register (C1MSL11DLC)		13-94 13-96
H'0080 15B6	CAN1 Message Slot 11 Data 0 (C1MSL11DT0)		CAN1 Message Slot 11 Data 1 (C1MSL11DT1)		13-98 13-100
H'0080 15B8	CAN1 Message Slot 11 Data 2 (C1MSL11DT2)		CAN1 Message Slot 11 Data 3 (C1MSL11DT3)		13-102 13-104
H'0080 15BA	CAN1 Message Slot 11 Data 4 (C1MSL11DT4)		CAN1 Message Slot 11 Data 5 (C1MSL11DT5)		13-106 13-108
H'0080 15BC	CAN1 Message Slot 11 Data 6 (C1MSL11DT6)		CAN1 Message Slot 11 Data 7 (C1MSL11DT7)		13-110 13-112
H'0080 15BE	CAN1 Message Slot 11 Timestamp (C1MSL11TSP)				13-114

CAN Module Related Register Map (15/19)

Address	+0 address		+1 address		See pages
	b0	b7	b8	b15	
H'0080 15C0	CAN1 Message Slot 12 Standard ID0 (C1MSL12SID0)		CAN1 Message Slot 12 Standard ID1 (C1MSL12SID1)		13-86 13-88
H'0080 15C2	CAN1 Message Slot 12 Extended ID0 (C1MSL12EID0)		CAN1 Message Slot 12 Extended ID1 (C1MSL12EID1)		13-90 13-92
H'0080 15C4	CAN1 Message Slot 12 Extended ID2 (C1MSL12EID2)		CAN1 Message Slot 12 Data Length Register (C1MSL12DLC)		13-94 13-96
H'0080 15C6	CAN1 Message Slot 12 Data 0 (C1MSL12DT0)		CAN1 Message Slot 12 Data 1 (C1MSL12DT1)		13-98 13-100
H'0080 15C8	CAN1 Message Slot 12 Data 2 (C1MSL12DT2)		CAN1 Message Slot 12 Data 3 (C1MSL12DT3)		13-102 13-104
H'0080 15CA	CAN1 Message Slot 12 Data 4 (C1MSL12DT4)		CAN1 Message Slot 12 Data 5 (C1MSL12DT5)		13-106 13-108
H'0080 15CC	CAN1 Message Slot 12 Data 6 (C1MSL12DT6)		CAN1 Message Slot 12 Data 7 (C1MSL12DT7)		13-110 13-112
H'0080 15CE	CAN1 Message Slot 12 Timestamp (C1MSL12TSP)				13-114
H'0080 15D0	CAN1 Message Slot 13 Standard ID0 (C1MSL13SID0)		CAN1 Message Slot 13 Standard ID1 (C1MSL13SID1)		13-86 13-88
H'0080 15D2	CAN1 Message Slot 13 Extended ID0 (C1MSL13EID0)		CAN1 Message Slot 13 Extended ID1 (C1MSL13EID1)		13-90 13-92
H'0080 15D4	CAN1 Message Slot 13 Extended ID2 (C1MSL13EID2)		CAN1 Message Slot 13 Data Length Register (C1MSL13DLC)		13-94 13-96
H'0080 15D6	CAN1 Message Slot 13 Data 0 (C1MSL13DT0)		CAN1 Message Slot 13 Data 1 (C1MSL13DT1)		13-98 13-100
H'0080 15D8	CAN1 Message Slot 13 Data 2 (C1MSL13DT2)		CAN1 Message Slot 13 Data 3 (C1MSL13DT3)		13-102 13-104
H'0080 15DA	CAN1 Message Slot 13 Data 4 (C1MSL13DT4)		CAN1 Message Slot 13 Data 5 (C1MSL13DT5)		13-106 13-108
H'0080 15DC	CAN1 Message Slot 13 Data 6 (C1MSL13DT6)		CAN1 Message Slot 13 Data 7 (C1MSL13DT7)		13-110 13-112
H'0080 15DE	CAN1 Message Slot 13 Timestamp (C1MSL13TSP)				13-114
H'0080 15E0	CAN1 Message Slot 14 Standard ID0 (C1MSL14SID0)		CAN1 Message Slot 14 Standard ID1 (C1MSL14SID1)		13-86 13-88
H'0080 15E2	CAN1 Message Slot 14 Extended ID0 (C1MSL14EID0)		CAN1 Message Slot 14 Extended ID1 (C1MSL14EID1)		13-90 13-92
H'0080 15E4	CAN1 Message Slot 14 Extended ID2 (C1MSL14EID2)		CAN1 Message Slot 14 Data Length Register (C1MSL14DLC)		13-94 13-96
H'0080 15E6	CAN1 Message Slot 14 Data 0 (C1MSL14DT0)		CAN1 Message Slot 14 Data 1 (C1MSL14DT1)		13-98 13-100
H'0080 15E8	CAN1 Message Slot 14 Data 2 (C1MSL14DT2)		CAN1 Message Slot 14 Data 3 (C1MSL14DT3)		13-102 13-104
H'0080 15EA	CAN1 Message Slot 14 Data 4 (C1MSL14DT4)		CAN1 Message Slot 14 Data 5 (C1MSL14DT5)		13-106 13-108
H'0080 15EC	CAN1 Message Slot 14 Data 6 (C1MSL14DT6)		CAN1 Message Slot 14 Data 7 (C1MSL14DT7)		13-110 13-112
H'0080 15EE	CAN1 Message Slot 14 Timestamp (C1MSL14TSP)				13-114
H'0080 15F0	CAN1 Message Slot 15 Standard ID0 (C1MSL15SID0)		CAN1 Message Slot 15 Standard ID1 (C1MSL15SID1)		13-86 13-88
H'0080 15F2	CAN1 Message Slot 15 Extended ID0 (C1MSL15EID0)		CAN1 Message Slot 15 Extended ID1 (C1MSL15EID1)		13-90 13-92
H'0080 15F4	CAN1 Message Slot 15 Extended ID2 (C1MSL15EID2)		CAN1 Message Slot 15 Data Length Register (C1MSL15DLC)		13-94 13-96
H'0080 15F6	CAN1 Message Slot 15 Data 0 (C1MSL15DT0)		CAN1 Message Slot 15 Data 1 (C1MSL15DT1)		13-98 13-100
H'0080 15F8	CAN1 Message Slot 15 Data 2 (C1MSL15DT2)		CAN1 Message Slot 15 Data 3 (C1MSL15DT3)		13-102 13-104
H'0080 15FA	CAN1 Message Slot 15 Data 4 (C1MSL15DT4)		CAN1 Message Slot 15 Data 5 (C1MSL15DT5)		13-106 13-108
H'0080 15FC	CAN1 Message Slot 15 Data 6 (C1MSL15DT6)		CAN1 Message Slot 15 Data 7 (C1MSL15DT7)		13-110 13-112
H'0080 15FE	CAN1 Message Slot 15 Timestamp (C1MSL15TSP)				13-114

CAN Module Related Register Map (16/19)

Address	+0 address		+1 address		See pages
	b0	b7	b8	b15	
H'0080 1600	CAN1 Message Slot 16 Standard ID0 (C1MSL16SID0)		CAN1 Message Slot 16 Standard ID1 (C1MSL16SID1)		13-87 13-89
H'0080 1602	CAN1 Message Slot 16 Extended ID0 (C1MSL16EID0)		CAN1 Message Slot 16 Extended ID1 (C1MSL16EID1)		13-91 13-93
H'0080 1604	CAN1 Message Slot 16 Extended ID2 (C1MSL16EID2)		CAN1 Message Slot 16 Data Length Register (C1MSL16DLC)		13-95 13-97
H'0080 1606	CAN1 Message Slot 16 Data 0 (C1MSL16DT0)		CAN1 Message Slot 16 Data 1 (C1MSL16DT1)		13-99 13-101
H'0080 1608	CAN1 Message Slot 16 Data 2 (C1MSL16DT2)		CAN1 Message Slot 16 Data 3 (C1MSL16DT3)		13-103 13-105
H'0080 160A	CAN1 Message Slot 16 Data 4 (C1MSL16DT4)		CAN1 Message Slot 16 Data 5 (C1MSL16DT5)		13-107 13-109
H'0080 160C	CAN1 Message Slot 16 Data 6 (C1MSL16DT6)		CAN1 Message Slot 16 Data 7 (C1MSL16DT7)		13-112 13-113
H'0080 160E	CAN1 Message Slot 16 Timestamp (C1MSL16TSP)				13-115
H'0080 1610	CAN1 Message Slot 17 Standard ID0 (C1MSL17SID0)		CAN1 Message Slot 17 Standard ID1 (C1MSL17SID1)		13-87 13-89
H'0080 1612	CAN1 Message Slot 17 Extended ID0 (C1MSL17EID0)		CAN1 Message Slot 17 Extended ID1 (C1MSL17EID1)		13-91 13-93
H'0080 1614	CAN1 Message Slot 17 Extended ID2 (C1MSL17EID2)		CAN1 Message Slot 17 Data Length Register (C1MSL17DLC)		13-95 13-97
H'0080 1616	CAN1 Message Slot 17 Data 0 (C1MSL17DT0)		CAN1 Message Slot 17 Data 1 (C1MSL17DT1)		13-99 13-101
H'0080 1618	CAN1 Message Slot 17 Data 2 (C1MSL17DT2)		CAN1 Message Slot 17 Data 3 (C1MSL17DT3)		13-103 13-105
H'0080 161A	CAN1 Message Slot 17 Data 4 (C1MSL17DT4)		CAN1 Message Slot 17 Data 5 (C1MSL17DT5)		13-107 13-109
H'0080 161C	CAN1 Message Slot 17 Data 6 (C1MSL17DT6)		CAN1 Message Slot 17 Data 7 (C1MSL17DT7)		13-112 13-113
H'0080 161E	CAN1 Message Slot 17 Timestamp (C1MSL17TSP)				13-115
H'0080 1620	CAN1 Message Slot 18 Standard ID0 (C1MSL18SID0)		CAN1 Message Slot 18 Standard ID1 (C1MSL18SID1)		13-87 13-89
H'0080 1622	CAN1 Message Slot 18 Extended ID0 (C1MSL18EID0)		CAN1 Message Slot 18 Extended ID1 (C1MSL18EID1)		13-91 13-93
H'0080 1624	CAN1 Message Slot 18 Extended ID2 (C1MSL18EID2)		CAN1 Message Slot 18 Data Length Register (C1MSL18DLC)		13-95 13-97
H'0080 1626	CAN1 Message Slot 18 Data 0 (C1MSL18DT0)		CAN1 Message Slot 18 Data 1 (C1MSL18DT1)		13-99 13-101
H'0080 1628	CAN1 Message Slot 18 Data 2 (C1MSL18DT2)		CAN1 Message Slot 18 Data 3 (C1MSL18DT3)		13-103 13-105
H'0080 162A	CAN1 Message Slot 18 Data 4 (C1MSL18DT4)		CAN1 Message Slot 18 Data 5 (C1MSL18DT5)		13-107 13-109
H'0080 162C	CAN1 Message Slot 18 Data 6 (C1MSL18DT6)		CAN1 Message Slot 18 Data 7 (C1MSL18DT7)		13-111 13-113
H'0080 162E	CAN1 Message Slot 18 Timestamp (C1MSL18TSP)				13-115
H'0080 1630	CAN1 Message Slot 19 Standard ID0 (C1MSL19SID0)		CAN1 Message Slot 19 Standard ID1 (C1MSL19SID1)		13-87 13-89
H'0080 1632	CAN1 Message Slot 19 Extended ID0 (C1MSL19EID0)		CAN1 Message Slot 19 Extended ID1 (C1MSL19EID1)		13-91 13-93
H'0080 1634	CAN1 Message Slot 19 Extended ID2 (C1MSL19EID2)		CAN1 Message Slot 19 Data Length Register (C1MSL19DLC)		13-95 13-97
H'0080 1636	CAN1 Message Slot 19 Data 0 (C1MSL19DT0)		CAN1 Message Slot 19 Data 1 (C1MSL19DT1)		13-99 13-101
H'0080 1638	CAN1 Message Slot 19 Data 2 (C1MSL19DT2)		CAN1 Message Slot 19 Data 3 (C1MSL19DT3)		13-103 13-105
H'0080 163A	CAN1 Message Slot 19 Data 4 (C1MSL19DT4)		CAN1 Message Slot 19 Data 5 (C1MSL19DT5)		13-107 13-109
H'0080 163C	CAN1 Message Slot 19 Data 6 (C1MSL19DT6)		CAN1 Message Slot 19 Data 7 (C1MSL19DT7)		13-112 13-113
H'0080 163E	CAN1 Message Slot 19 Timestamp (C1MSL19TSP)				13-115



CAN Module Related Register Map (17/19)

Address	+0 address		+1 address		See pages
	b0	b7	b8	b15	
H'0080 1640	CAN1 Message Slot 20 Standard ID0 (C1MSL20SID0)		CAN1 Message Slot 20 Standard ID1 (C1MSL20SID1)		13-87 13-89
H'0080 1642	CAN1 Message Slot 20 Extended ID0 (C1MSL20EID0)		CAN1 Message Slot 20 Extended ID1 (C1MSL20EID1)		13-91 13-93
H'0080 1644	CAN1 Message Slot 20 Extended ID2 (C1MSL20EID2)		CAN1 Message Slot 20 Data Length Register (C1MSL20DLC)		13-95 13-97
H'0080 1646	CAN1 Message Slot 20 Data 0 (C1MSL20DT0)		CAN1 Message Slot 20 Data 1 (C1MSL20DT1)		13-99 13-101
H'0080 1648	CAN1 Message Slot 20 Data 2 (C1MSL20DT2)		CAN1 Message Slot 20 Data 3 (C1MSL20DT3)		13-103 13-105
H'0080 164A	CAN1 Message Slot 20 Data 4 (C1MSL20DT4)		CAN1 Message Slot 20 Data 5 (C1MSL20DT5)		13-107 13-109
H'0080 164C	CAN1 Message Slot 20 Data 6 (C1MSL20DT6)		CAN1 Message Slot 20 Data 7 (C1MSL20DT7)		13-112 13-113
H'0080 164E	CAN1 Message Slot 20 Timestamp (C1MSL20TSP)				13-115
H'0080 1650	CAN1 Message Slot 21 Standard ID0 (C1MSL21SID0)		CAN1 Message Slot 21 Standard ID1 (C1MSL21SID1)		13-87 13-89
H'0080 1652	CAN1 Message Slot 21 Extended ID0 (C1MSL21EID0)		CAN1 Message Slot 21 Extended ID1 (C1MSL21EID1)		13-91 13-93
H'0080 1654	CAN1 Message Slot 21 Extended ID2 (C1MSL21EID2)		CAN1 Message Slot 21 Data Length Register (C1MSL21DLC)		13-95 13-97
H'0080 1656	CAN1 Message Slot 21 Data 0 (C1MSL21DT0)		CAN1 Message Slot 21 Data 1 (C1MSL21DT1)		13-99 13-101
H'0080 1658	CAN1 Message Slot 21 Data 2 (C1MSL21DT2)		CAN1 Message Slot 21 Data 3 (C1MSL21DT3)		13-103 13-105
H'0080 165A	CAN1 Message Slot 21 Data 4 (C1MSL21DT4)		CAN1 Message Slot 21 Data 5 (C1MSL21DT5)		13-107 13-109
H'0080 165C	CAN1 Message Slot 21 Data 6 (C1MSL21DT6)		CAN1 Message Slot 21 Data 7 (C1MSL21DT7)		13-112 13-113
H'0080 165E	CAN1 Message Slot 21 Timestamp (C1MSL21TSP)				13-115
H'0080 1660	CAN1 Message Slot 22 Standard ID0 (C1MSL22SID0)		CAN1 Message Slot 22 Standard ID1 (C1MSL22SID1)		13-87 13-89
H'0080 1662	CAN1 Message Slot 22 Extended ID0 (C1MSL22EID0)		CAN1 Message Slot 22 Extended ID1 (C1MSL22EID1)		13-91 13-93
H'0080 1664	CAN1 Message Slot 22 Extended ID2 (C1MSL22EID2)		CAN1 Message Slot 22 Data Length Register (C1MSL22DLC)		13-95 13-97
H'0080 1666	CAN1 Message Slot 22 Data 0 (C1MSL22DT0)		CAN1 Message Slot 22 Data 1 (C1MSL22DT1)		13-99 13-101
H'0080 1668	CAN1 Message Slot 22 Data 2 (C1MSL22DT2)		CAN1 Message Slot 22 Data 3 (C1MSL22DT3)		13-103 13-105
H'0080 166A	CAN1 Message Slot 22 Data 4 (C1MSL22DT4)		CAN1 Message Slot 22 Data 5 (C1MSL22DT5)		13-107 13-109
H'0080 166C	CAN1 Message Slot 22 Data 6 (C1MSL22DT6)		CAN1 Message Slot 22 Data 7 (C1MSL22DT7)		13-112 13-113
H'0080 166E	CAN1 Message Slot 22 Timestamp (C1MSL22TSP)				13-115
H'0080 1670	CAN1 Message Slot 23 Standard ID0 (C1MSL23SID0)		CAN1 Message Slot 23 Standard ID1 (C1MSL23SID1)		13-87 13-89
H'0080 1672	CAN1 Message Slot 23 Extended ID0 (C1MSL23EID0)		CAN1 Message Slot 23 Extended ID1 (C1MSL23EID1)		13-91 13-93
H'0080 1674	CAN1 Message Slot 23 Extended ID2 (C1MSL23EID2)		CAN1 Message Slot 23 Data Length Register (C1MSL23DLC)		13-95 13-97
H'0080 1676	CAN1 Message Slot 23 Data 0 (C1MSL23DT0)		CAN1 Message Slot 23 Data 1 (C1MSL23DT1)		13-99 13-101
H'0080 1678	CAN1 Message Slot 23 Data 2 (C1MSL23DT2)		CAN1 Message Slot 23 Data 3 (C1MSL23DT3)		13-103 13-105
H'0080 167A	CAN1 Message Slot 23 Data 4 (C1MSL23DT4)		CAN1 Message Slot 23 Data 5 (C1MSL23DT5)		13-107 13-109
H'0080 167C	CAN1 Message Slot 23 Data 6 (C1MSL23DT6)		CAN1 Message Slot 23 Data 7 (C1MSL23DT7)		13-112 13-113
H'0080 167E	CAN1 Message Slot 23 Timestamp (C1MSL23TSP)				13-115

CAN Module Related Register Map (18/19)

Address	+0 address		+1 address		See pages
	b0	b7	b8	b15	
H'0080 1680	CAN1 Message Slot 24 Standard ID0 (C1MSL24SID0)		CAN1 Message Slot 24 Standard ID1 (C1MSL24SID1)		13-87 13-89
H'0080 1682	CAN1 Message Slot 24 Extended ID0 (C1MSL24EID0)		CAN1 Message Slot 24 Extended ID1 (C1MSL24EID1)		13-91 13-93
H'0080 1684	CAN1 Message Slot 24 Extended ID2 (C1MSL24EID2)		CAN1 Message Slot 24 Data Length Register (C1MSL24DLC)		13-95 13-97
H'0080 1686	CAN1 Message Slot 24 Data 0 (C1MSL24DT0)		CAN1 Message Slot 24 Data 1 (C1MSL24DT1)		13-99 13-101
H'0080 1688	CAN1 Message Slot 24 Data 2 (C1MSL24DT2)		CAN1 Message Slot 24 Data 3 (C1MSL24DT3)		13-103 13-105
H'0080 168A	CAN1 Message Slot 24 Data 4 (C1MSL24DT4)		CAN1 Message Slot 24 Data 5 (C1MSL24DT5)		13-107 13-109
H'0080 168C	CAN1 Message Slot 24 Data 6 (C1MSL24DT6)		CAN1 Message Slot 24 Data 7 (C1MSL24DT7)		13-112 13-113
H'0080 168E	CAN1 Message Slot 24 Timestamp (C1MSL24TSP)				13-115
H'0080 1690	CAN1 Message Slot 25 Standard ID0 (C1MSL25SID0)		CAN1 Message Slot 25 Standard ID1 (C1MSL25SID1)		13-87 13-89
H'0080 1692	CAN1 Message Slot 25 Extended ID0 (C1MSL25EID0)		CAN1 Message Slot 25 Extended ID1 (C1MSL25EID1)		13-91 13-93
H'0080 1694	CAN1 Message Slot 25 Extended ID2 (C1MSL25EID2)		CAN1 Message Slot 25 Data Length Register (C1MSL25DLC)		13-95 13-97
H'0080 1696	CAN1 Message Slot 25 Data 0 (C1MSL25DT0)		CAN1 Message Slot 25 Data 1 (C1MSL25DT1)		13-99 13-101
H'0080 1698	CAN1 Message Slot 25 Data 2 (C1MSL25DT2)		CAN1 Message Slot 25 Data 3 (C1MSL25DT3)		13-103 13-105
H'0080 169A	CAN1 Message Slot 25 Data 4 (C1MSL25DT4)		CAN1 Message Slot 25 Data 5 (C1MSL25DT5)		13-107 13-109
H'0080 169C	CAN1 Message Slot 25 Data 6 (C1MSL25DT6)		CAN1 Message Slot 25 Data 7 (C1MSL25DT7)		13-112 13-113
H'0080 169E	CAN1 Message Slot 25 Timestamp (C1MSL25TSP)				13-115
H'0080 16A0	CAN1 Message Slot 26 Standard ID0 (C1MSL26SID0)		CAN1 Message Slot 26 Standard ID1 (C1MSL26SID1)		13-87 13-89
H'0080 16A2	CAN1 Message Slot 26 Extended ID0 (C1MSL26EID0)		CAN1 Message Slot 26 Extended ID1 (C1MSL26EID1)		13-91 13-93
H'0080 16A4	CAN1 Message Slot 26 Extended ID2 (C1MSL26EID2)		CAN1 Message Slot 26 Data Length Register (C1MSL26DLC)		13-95 13-97
H'0080 16A6	CAN1 Message Slot 26 Data 0 (C1MSL26DT0)		CAN1 Message Slot 26 Data 1 (C1MSL26DT1)		13-99 13-101
H'0080 16A8	CAN1 Message Slot 26 Data 2 (C1MSL26DT2)		CAN1 Message Slot 26 Data 3 (C1MSL26DT3)		13-103 13-105
H'0080 16AA	CAN1 Message Slot 26 Data 4 (C1MSL26DT4)		CAN1 Message Slot 26 Data 5 (C1MSL26DT5)		13-107 13-109
H'0080 16AC	CAN1 Message Slot 26 Data 6 (C1MSL26DT6)		CAN1 Message Slot 26 Data 7 (C1MSL26DT7)		13-112 13-113
H'0080 16AE	CAN1 Message Slot 26 Timestamp (C1MSL26TSP)				13-115
H'0080 16B0	CAN1 Message Slot 27 Standard ID0 (C1MSL27SID0)		CAN1 Message Slot 27 Standard ID1 (C1MSL27SID1)		13-87 13-89
H'0080 16B2	CAN1 Message Slot 27 Extended ID0 (C1MSL27EID0)		CAN1 Message Slot 27 Extended ID1 (C1MSL27EID1)		13-91 13-93
H'0080 16B4	CAN1 Message Slot 27 Extended ID2 (C1MSL27EID2)		CAN1 Message Slot 27 Data Length Register (C1MSL27DLC)		13-95 13-97
H'0080 16B6	CAN1 Message Slot 27 Data 0 (C1MSL27DT0)		CAN1 Message Slot 27 Data 1 (C1MSL27DT1)		13-99 13-101
H'0080 16B8	CAN1 Message Slot 27 Data 2 (C1MSL27DT2)		CAN1 Message Slot 27 Data 3 (C1MSL27DT3)		13-103 13-105
H'0080 16BA	CAN1 Message Slot 27 Data 4 (C1MSL27DT4)		CAN1 Message Slot 27 Data 5 (C1MSL27DT5)		13-107 13-109
H'0080 16BC	CAN1 Message Slot 27 Data 6 (C1MSL27DT6)		CAN1 Message Slot 27 Data 7 (C1MSL27DT7)		13-112 13-113
H'0080 16BE	CAN1 Message Slot 27 Timestamp (C1MSL27TSP)				13-115

CAN Module Related Register Map (19/19)

Address	+0 address		+1 address		See pages
	b0	b7	b8	b15	
H'0080 16C0	CAN1 Message Slot 28 Standard ID0 (C1MSL28SID0)		CAN1 Message Slot 28 Standard ID1 (C1MSL28SID1)		13-87 13-89
H'0080 16C2	CAN1 Message Slot 28 Extended ID0 (C1MSL28EID0)		CAN1 Message Slot 28 Extended ID1 (C1MSL28EID1)		13-91 13-93
H'0080 16C4	CAN1 Message Slot 28 Extended ID2 (C1MSL28EID2)		CAN1 Message Slot 28 Data Length Register (C1MSL28DLC)		13-95 13-97
H'0080 16C6	CAN1 Message Slot 28 Data 0 (C1MSL28DT0)		CAN1 Message Slot 28 Data 1 (C1MSL28DT1)		13-99 13-101
H'0080 16C8	CAN1 Message Slot 28 Data 2 (C1MSL28DT2)		CAN1 Message Slot 28 Data 3 (C1MSL28DT3)		13-103 13-105
H'0080 16CA	CAN1 Message Slot 28 Data 4 (C1MSL28DT4)		CAN1 Message Slot 28 Data 5 (C1MSL28DT5)		13-107 13-109
H'0080 16CC	CAN1 Message Slot 28 Data 6 (C1MSL28DT6)		CAN1 Message Slot 28 Data 7 (C1MSL28DT7)		13-112 13-113
H'0080 16CE	CAN1 Message Slot 28 Timestamp (C1MSL28TSP)				13-115
H'0080 16D0	CAN1 Message Slot 29 Standard ID0 (C1MSL29SID0)		CAN1 Message Slot 29 Standard ID1 (C1MSL29SID1)		13-87 13-89
H'0080 16D2	CAN1 Message Slot 29 Extended ID0 (C1MSL29EID0)		CAN1 Message Slot 29 Extended ID1 (C1MSL29EID1)		13-91 13-93
H'0080 16D4	CAN1 Message Slot 29 Extended ID2 (C1MSL29EID2)		CAN1 Message Slot 29 Data Length Register (C1MSL29DLC)		13-95 13-97
H'0080 16D6	CAN1 Message Slot 29 Data 0 (C1MSL29DT0)		CAN1 Message Slot 29 Data 1 (C1MSL29DT1)		13-99 13-101
H'0080 16D8	CAN1 Message Slot 29 Data 2 (C1MSL29DT2)		CAN1 Message Slot 29 Data 3 (C1MSL29DT3)		13-103 13-105
H'0080 16DA	CAN1 Message Slot 29 Data 4 (C1MSL29DT4)		CAN1 Message Slot 29 Data 5 (C1MSL29DT5)		13-107 13-109
H'0080 16DC	CAN1 Message Slot 29 Data 6 (C1MSL29DT6)		CAN1 Message Slot 29 Data 7 (C1MSL29DT7)		13-112 13-113
H'0080 16DE	CAN1 Message Slot 29 Timestamp (C1MSL29TSP)				13-115
H'0080 16E0	CAN1 Message Slot 30 Standard ID0 (C1MSL30SID0)		CAN1 Message Slot 30 Standard ID1 (C1MSL30SID1)		13-87 13-89
H'0080 16E2	CAN1 Message Slot 30 Extended ID0 (C1MSL30EID0)		CAN1 Message Slot 30 Extended ID1 (C1MSL30EID1)		13-91 13-93
H'0080 16E4	CAN1 Message Slot 30 Extended ID2 (C1MSL30EID2)		CAN1 Message Slot 30 Data Length Register (C1MSL30DLC)		13-95 13-97
H'0080 16E6	CAN1 Message Slot 30 Data 0 (C1MSL30DT0)		CAN1 Message Slot 30 Data 1 (C1MSL30DT1)		13-99 13-101
H'0080 16E8	CAN1 Message Slot 30 Data 2 (C1MSL30DT2)		CAN1 Message Slot 30 Data 3 (C1MSL30DT3)		13-103 13-105
H'0080 16EA	CAN1 Message Slot 30 Data 4 (C1MSL30DT4)		CAN1 Message Slot 30 Data 5 (C1MSL30DT5)		13-107 13-109
H'0080 16EC	CAN1 Message Slot 30 Data 6 (C1MSL30DT6)		CAN1 Message Slot 30 Data 7 (C1MSL30DT7)		13-112 13-113
H'0080 16EE	CAN1 Message Slot 30 Timestamp (C1MSL30TSP)				13-115
H'0080 16F0	CAN1 Message Slot 31 Standard ID0 (C1MSL31SID0)		CAN1 Message Slot 31 Standard ID1 (C1MSL31SID1)		13-87 13-89
H'0080 16F2	CAN1 Message Slot 31 Extended ID0 (C1MSL31EID0)		CAN1 Message Slot 31 Extended ID1 (C1MSL31EID1)		13-91 13-93
H'0080 16F4	CAN1 Message Slot 31 Extended ID2 (C1MSL31EID2)		CAN1 Message Slot 31 Data Length Register (C1MSL31DLC)		13-95 13-97
H'0080 16F6	CAN1 Message Slot 31 Data 0 (C1MSL31DT0)		CAN1 Message Slot 31 Data 1 (C1MSL31DT1)		13-99 13-101
H'0080 16F8	CAN1 Message Slot 31 Data 2 (C1MSL31DT2)		CAN1 Message Slot 31 Data 3 (C1MSL31DT3)		13-103 13-105
H'0080 16FA	CAN1 Message Slot 31 Data 4 (C1MSL31DT4)		CAN1 Message Slot 31 Data 5 (C1MSL31DT5)		13-107 13-109
H'0080 16FC	CAN1 Message Slot 31 Data 6 (C1MSL31DT6)		CAN1 Message Slot 31 Data 7 (C1MSL31DT7)		13-112 13-113
H'0080 16FE	CAN1 Message Slot 31 Timestamp (C1MSL31TSP)				13-115



### 13.2.1 CAN Bus Mode Control Register

CAN Bus Mode Control Register (CANBUSCR)

<Address: H'0080 052A>

b0	1	2	3	4	5	6	b7
0	0	0	0	0	0	CBUSSELP 0	CBUSSEL 0

<Upon exiting reset: H'00>

b	Bit Name	Function	R	W
0-5	No function assigned. Fix to "0."		0	0
6	CBUSSELP CBUSSEL write control bit		0	W
7	CBUSSEL CAN bus mode select bit	0: CAN0/CAN1 CAN bus independent 1: CAN0/CAN1 CAN bus share	R	W

Note: • Change this register value with FRST bits (inside the CAN control register) of both CAN0 & CAN1 set at "1."

By setting the CBUSSEL bit to "1," two CAN modules are internally connected, which can be used artificially as 64-slot CAN.

#### • When CBUSSEL = 0

CAN0 and CAN1 use CTX0/CRX0 and CTX1/CRX1 as a pin, respectively.

#### • When CBUSSEL = 1

Both CAN0 and CAN1 use CTX0/CRX0 as a pin.

When CAN0 / CAN1 CAN bus share (CBUSSEL = 1 ) are described below.

- Do not select CTX1/CRX1 with the port operation mode register/port peripheral function select register.
- When both CANs generate a transmit request and both CAN0/CAN1 in operation, the output of CAN having ID with higher priority corresponds to CTX0 output due to internal arbitration. Also, the CAN lost in arbitration then operates as a receiving node, but no dominant level is output in the ACK field.
- In case where both CAN0 and CAN1 are operated, the CANs do not perform operation as error passive node as viewed from the outside unless the both of them are in error passive state. The CANs do not perform operation as error bus off node as viewed from the outside unless the both of them are in error bus off state. Therefore, consideration is required such as making both CANs error states the same in software.
- Do not set the transmit slot that has the same ID in both CAN0 and CAN1.
- When both CAN0 and CAN1 are being operated, if there is a slot which completes one CAN transmission and meets the receiving conditions by the other CAN, "the other CAN" stores the received data.

When set this register, procedure is described below.

1. Write "1" in CBUSSELP write control bit (CBUSSELP)
2. Following 1. write "0" in CBUSSELP write control bit (CBUSSELP), write "0" or "1" in CBUSSEL output prohibition select bit (CBUSSEL)

Note: • If there are writing cycles from CPU, DMA, SDI (tool), NBD to any other area between 1 and 2, the continuous setting (A pair of two consecutive is 1 set for writing operation) is disabled and the writing value is not reflected. Therefore, disable interrupts and DMA transfers before setting. However the writing cycle from RTD and DRI are not effected.

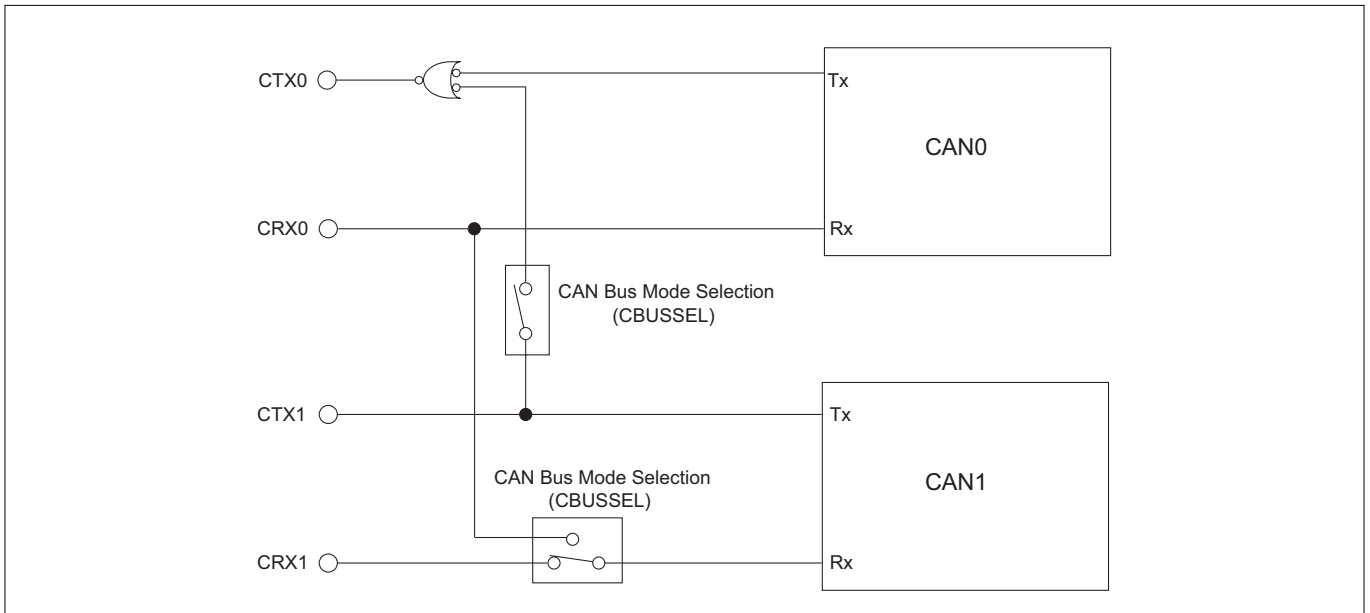
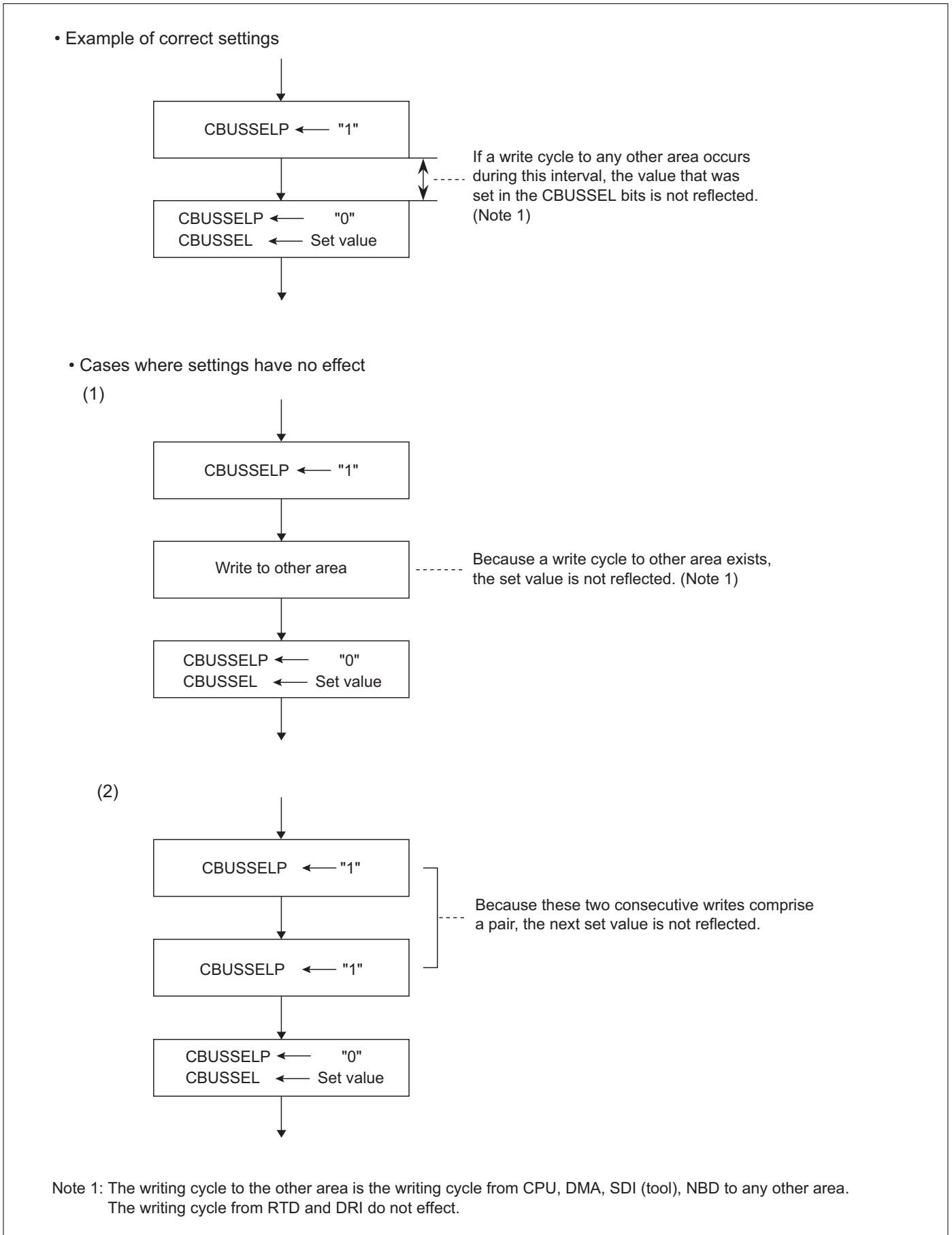


Figure 13.2.1 Configuration of the CAN Bus Mode Selection Circuit (Image)



**Figure 13.2.2 CBUSSEL Setting Procedure**

## 13.2.2 CAN Control Registers

CAN0 Control Register (CAN0CNT)

&lt;Address: H'0080 1000&gt;

CAN1 Control Register (CAN1CNT)

&lt;Address: H'0080 1400&gt;

b0	1	2	3	4	5	6	7	8	9	10	11	12	13	14	b15
				RBO	TSR	TSP					FRST	BCM		LBM	RST
0				0	0	0	0	0	0	0	1	0	0	0	1

&lt;Upon exiting reset: H'0011&gt;

b	Bit Name	Function	R	W
0-3	No function assigned. Fix to "0."		0	0
4	RBO Return bus off bit	0: Enable normal operation 1: Request clearing of error counter	R	(Note 1)
5	TSR Timestamp counter reset bit	0: Enable count operation 1: Initialize count (to H'0000)	R	(Note 1)
6-7	TSP Timestamp prescaler bit	00: Select CAN bus bit clock 01: Select CAN bus bit clock divided by 2 10: Select CAN bus bit clock divided by 3 11: Select CAN bus bit clock divided by 4	R	W
8-10	No function assigned. Fix to "0."		0	0
11	FRST Forcible reset bit	0: Negate reset 1: Forcibly reset	R	W
12	BCM BasicCAN mode bit	0: Disable BasicCAN mode 1: BasicCAN mode	R	W
13	No function assigned. Fix to "0."		0	0
14	LBM Loopback mode bit	0: Disable loopback function 1: Enable loopback function	R	W
15	RST CAN reset bit	0: Negate reset 1: Request reset	R	W

Note 1: Only writing "1" is effective. Automatically cleared to "0" in hardware.

**(1) RBO (Return Bus Off) bit (Bit 4)**

Setting this bit to "1" under bus off stage clears the CAN Receive Error Count Register (CAN0REC, CAN1REC) and CAN Transmit Error Count Register (CAN0TEC, CAN1TEC) to H'00 and forcibly places the CAN module into an error active state. This bit is cleared when the CAN module goes to an error active state.

- Notes:
- Communication becomes possible when 11 consecutive recessive bits are detected on the CAN bus after clearing the error counters.
  - Do not set this bit to "1" under the error active state and communication enable condition in the error passive state.

**(2) TSR (Timestamp Counter Reset) bit (Bit 5)**

Setting this bit to "1" clears the value of the CAN Timestamp Count Register (CAN0TSTMP, CAN1TSTMP) to H'0000. This bit is cleared after the value of the CAN Timestamp Count Register (CAN0TSTMP, CAN1TSTMP) is cleared to H'0000.

**(3) TSP (Timestamp Prescaler) bits (Bits 6, 7)**

These bits select the count clock source for the timestamp counter.

- Note:
- Do not change settings of the TSP bits while CAN is operating (CAN Status Register CRS bit = "0").

**(4) FRST (Forcible Reset) bit (Bit 11)**

When the FRST bit is set to "1," the CAN module is separated from the CAN bus and the protocol control unit is reset regardless of whether the CAN module currently is communicating. Up to 5 BCLK periods are required before the protocol control unit is reset after setting the FRST bit.

- Notes:
- In order for CAN communication to start, the FRST and RST bits must be cleared to "0."
  - If the FRST bit is set to "1" during communication, the CTX pin output goes "H" (fixed) immediately after that. Therefore, setting the FRST bit to "1" while sending CAN frame may cause a CAN bus error.
  - The CAN Message Slot Control Register's transmit/receive requests are not cleared for reasons that the FRST or RST bits are set.
  - When the protocol control unit is reset by setting the FRST bit to "1," the CAN Timestamp Count and CAN Transmit/Receive Error Count Registers are initialized to "0."

**(5) BCM (BasicCAN Mode) bit (Bit 12)**

By setting this bit to "1," local slot 30 and 31 of the CAN module can be operated in BasicCAN mode.

**• Operation during BasicCAN mode**

During BasicCAN mode, two local slots—slots 30 and 31—are used as dual buffers, and the received frames with matching ID are stored alternately in slots 30 and 31 by acceptance filtering. Used for this acceptance filtering when slot 30 is active (next received frame to be stored in slot 30) are the ID set in slot 30 and local mask A, and those when slot 31 is active are the ID set in slot 31 and local mask B. Two types of frames—data frame and remote frame—can be received in this mode. By setting the same ID and the same mask register value for the two slots, the possibility of losing messages when, for example, receiving frames which have many IDs may be reduced.

**• Procedure for entering BasicCAN mode**

Follow the procedure below during initialization:

- 1) Set the ID for slots 30 and 31 and the local mask registers A and B. (We recommend setting the same value.)
- 2) Set the frame types to be handled by slots 30 and 31 (standard or extended) in the CAN Frame Format Select Register. (We recommend setting the same type.)
- 3) Set the Message Slot Control Registers for slots 30 and 31 for data frame reception.
- 4) Set the BCM bit to "1."

- Notes:
- Do not change settings of the BCM bit while CAN is operating (CAN Status Register CRS bit = "0").
  - The first slot that is active after clearing the RST bit is slot 30.
  - Even during BasicCAN mode, slots 0 to 29 can be used the same way as in normal operation.

**(6) LBM (Loopback Mode) bit (Bit 14)**

When the LBM bit is set to "1," if a receive slot exists whose ID matches that of the frame sent by the CAN module itself, then the frame can be received.

- Notes:
- ACK is not returned for the frame sent by itself.
  - Do not change settings of the LBM bit while CAN is operating (CAN Status Register CRS bit = "0").
  - After complete sending Frame correctly, TSC bit in CAN status register (CANnSTAT) is "1", but RSC bit is not "1." And it is possible to symbiotic for transmit complete interrupt request and receive complete interrupt request.

**(7) RST (CAN Reset) bit (Bit 15)**

When the RST bit is cleared to "0," the CAN module is connected to the CAN bus and becomes ready to communicate after detecting 11 consecutive recessive bits. Also, the CAN Timestamp Count Register thereby starts counting. When the RST bit is set to "1," the bus enters an idle state after sending frames from the slots which have transmit requests set by that time. Then, the protocol control unit enters a reset state and the CAN module is disconnected from the CAN bus. Frames received during this time are processed normally.

When setting RST bit to "1" under bus off state, it exits from bus off state after detecting 11 consecutive recessive bits on CAN bus 128 times, and then protocol control unit enters a reset state.

- Notes:
- It is inhibited to set a new transmit request until the protocol control unit is reset (CAN Status Register CRS bit is set to "1") after setting the RST bit to "1."
  - When the protocol control unit is reset by setting the RST bit to "1," the CAN Timestamp Count and CAN Transmit/Receive Error Count Registers are initialized to "0."
  - In order for CAN communication to start, the FRST and RST bits must be cleared to "0."

#### 13.2.3 CAN Status Registers

CAN0 Status Register (CAN0STAT)

<Address: H'0080 1002>

CAN1 Status Register (CAN1STAT)

<Address: H'0080 1402>

b0	1	2	3	4	5	6	7	8	9	10	11	12	13	14	b15
0	BOS 0	EPS 0	CBS 0	BCS 0	0	LBS 0	CRS 1	RSB 0	TSB 0	RSC 0	TSC 0	MSN 0 0 0 0			

<Upon exiting reset: H'0100>

b	Bit Name	Function	R	W
0	No function assigned. Fix to "0."		0	0
1	BOS Bus off status bit	0: Not bus off 1: Bus off state	R	-
2	EPS Error passive status bit	0: Not error passive 1: Error passive state	R	-
3	CBS CAN bus error bit	0: No error occurred 1: Error occurred	R	-
4	BCS BasicCAN status bit	0: Normal mode 1: BasicCAN mode	R	-
5	No function assigned. Fix to "0."		0	0
6	LBS Loopback status bit	0: Normal mode 1: Loopback mode	R	-
7	CRS CAN reset status bit	0: Operating 1: Reset	R	-
8	RSB Receive status bit	0: Not receiving 1: Receiving	R	-
9	TSB Transmit status bit	0: Not sending 1: Sending	R	-
10	RSC Reception completed status bit	0: Reception not completed 1: Reception completed	R	-
11	TSC Transmission completed status bit	0: Transmission not completed 1: Transmission completed	R	-
12-15	MSN Message slot number bit	Number of the message slot which has finished sending or receiving (Note 1) 0000: Slot 0 0001: Slot 1 0010: Slot 2 0011: Slot 3 0100: Slot 4 0101: Slot 5 0110: Slot 6 0111: Slot 7 1000: Slot 8 1001: Slot 9 1010: Slot 10 1011: Slot 11 1100: Slot 12 1101: Slot 13 1110: Slot 14 1111: Slot 15	R	-

Note 1: When all these slots (32 slots) are used, refer to "CANn Message Slot Number Register (CANnMSN)."

**(1) BOS (Bus Off Status) bit (Bit 1)**

When BOS bit = "1," it means that the CAN module is in a bus off state.

**[Set condition]**

This bit is set to "1" when the transmit error count register value exceeded 255 and a bus off state is entered.

**[Clear condition]**

This bit is cleared when restored from the bus off state.

**(2) EPS (Error Passive Status) bit (Bit 2)**

When EPS bit = "1," it means that the CAN module is in an error passive state.

**[Set condition]**

This bit is set to "1" when the transmit or receive error count register value exceeded 127 and an error passive state is entered.

**[Clear condition]**

This bit is cleared when restored from the error passive state.

**(3) CBS (CAN Bus Error) bit (Bit 3)****[Set condition]**

This bit is set to "1" when an error is detected on the CAN bus.

**[Clear condition]**

This bit is cleared when the CAN module finished sending or receiving normally.

**(4) BCS (BasicCAN Status) bit (Bit 4)**

When BCS bit = "1," it means that the CAN module is operating in BasicCAN mode.

**[Set condition]**

This bit is set to "1" when the CAN module is operating in BasicCAN mode. BasicCAN mode is useful when the following conditions are met:

- CAN Control Register BCM bit = "1"
- Slots 30 and 31 both are set for data frame reception

**[Clear condition]**

This bit is cleared by clearing the BCM bit to "0."

**(5) LBS (Loopback Status) bit (Bit 6)**

When LBS bit = "1," it means that the CAN module is operating in loopback mode.

**[Set condition]**

This bit is set to "1" by setting the CAN Control Register LBM (loopback mode) bit to "1."

**[Clear condition]**

This bit is cleared by clearing the LBM bit to "0."



**(6) CRS (CAN Reset Status) bit (Bit 7)**

When CRS bit = "1," it means that the protocol control unit is in a reset state.

**[Set condition]**

This bit is set to "1" when the CAN protocol control unit is in a reset state.

**[Clear condition]**

This bit is cleared by clearing the CAN Control Register RST (CAN reset) and FRST bits to "0."  
However, it requires one bit of set baud rate worth of time to have CRS bit cleared to "0" after RST bit and FRST bit are cleared to "0."

**(7) RSB (Receive Status) bit (Bit 8)****[Set condition]**

This bit is set to "1" when the CAN module is operating as a receive node.

**[Clear condition]**

This bit is cleared when the CAN module starts operating as a transmit node or enters a bus idle state.

**(8) TSB (Transmit Status) bit (Bit 9)****[Set condition]**

This bit is set to "1" when the CAN module is operating as a transmit node.

**[Clear condition]**

This bit is cleared when the CAN module starts operating as a receive node or enters a bus idle state.

**(9) RSC (Reception Completed Status) bit (Bit 10)****[Set condition]**

This bit is set to "1" when the CAN module has finished receiving normally (regardless of whether there is any slot that meets receive conditions).

**[Clear condition]**

This bit is cleared when the CAN module has finished sending normally.

**(10) TSC (Transmission Completed Status) bit (Bit 11)****[Set condition]**

This bit is set to "1" when the CAN module has finished sending normally.

**[Clear condition]**

This bit is cleared when the CAN module has finished receiving normally.

**(11) MSN (Message Slot Number) bits (Bits 12–15)**

These bits indicate lower 4 bits of the relevant slot number when the CAN module has finished sending or finished storing the received data.

Slots 0 to 15 and 16 to 31 have the same value. When only slots 0 to 15 or slots 16 to 31 are used, these bits can be read out simultaneously with other status bits. In the case where all slots are used, refer to "CANn Message Slot Number Register (CANnMSN)."

These bits cannot be cleared to "0" in software.

Note: • When CAN module receives the frame that is transmitted by the CAN module itself during loopback mode, the MSN bits indicate the transmit slot number.

#### 13.2.4 CAN Configuration Registers

CAN0 Configuration Register (CAN0CONF)

<Address: H'0080 1006>

CAN1 Configuration Register (CAN1CONF)

<Address: H'0080 1406>

b0	1	2	3	4	5	6	7	8	9	10	11	12	13	14	b15
SJW		PH2			PH1			PRB			SAM				
0	0	0	0	0	0	0	0	0	0	0	0	0	0	0	0

<Upon exiting reset: H'0000>

b	Bit Name	Function	R	W
0-1	SJW reSynchronization Jump Width setting bit	00: SJW = 1Tq 01: SJW = 2Tq 10: SJW = 3Tq 11: SJW = 4Tq	R	W
2-4	PH2 Phase Segment2 setting bit	000: Phase Segment2 = 1Tq 001: Phase Segment2 = 2Tq 010: Phase Segment2 = 3Tq 011: Phase Segment2 = 4Tq 100: Phase Segment2 = 5Tq 101: Phase Segment2 = 6Tq 110: Phase Segment2 = 7Tq 111: Phase Segment2 = 8Tq	R	W
5-7	PH1 Phase Segment1 setting bit	000: Phase Segment1 = 1Tq 001: Phase Segment1 = 2Tq 010: Phase Segment1 = 3Tq 011: Phase Segment1 = 4Tq 100: Phase Segment1 = 5Tq 101: Phase Segment1 = 6Tq 110: Phase Segment1 = 7Tq 111: Phase Segment1 = 8Tq	R	W
8-10	PRB Propagation Segment setting bit	000: Propagation Segment = 1Tq 001: Propagation Segment = 2Tq 010: Propagation Segment = 3Tq 011: Propagation Segment = 4Tq 100: Propagation Segment = 5Tq 101: Propagation Segment = 6Tq 110: Propagation Segment = 7Tq 111: Propagation Segment = 8Tq	R	W
11	SAM Sampling count select bit	0: Sampled one time 1: Sampled three times	R	W
12-15	No function assigned. Fix to "0."		0	0

Notes: • Do not change settings of the CAN Configuration Register (CAN0CONF or CAN1CONF) during CAN operation (CAN Status Register CRS bit = "0").

- Bit configuration is specified by the CAN protocol specification in such a way that it satisfies the conditions given below:
    - Number of Tq's for one bit: 8-25 Tq's
    - $SJW \leq \min(\text{Phase Segment1}, \text{Phase Segment2})$
    - $\text{Phase Segment2} = \max(\text{Phase Segment1}, IPT^*)$  where  $IPT = 1$  for the internal CAN modules of the 32192/32195/32196 min() is the function that returns the smaller of two values; max() is the function that returns the maximum value.
- \*IPT is an abbreviation for Information Processing Time, which is the time immediately after the sampling point.

**(1) SJW bits (Bits 0–1)**

These bits set the reSynchronization Jump Width.

**(2) PH2 bits (Bits 2–4)**

These bits set the width of Phase Segment2.

**(3) PH1 bits (Bits 5–7)**

These bits set the width of Phase Segment1.

**(4) PRB bits (Bits 8–10)**

These bits set the width of Propagation Segment.

**(5) SAM bit (Bit 11)**

This bit sets the number of times each bit is sampled. When SAM = "0," the value sampled at the end of Phase Segment1 is assumed to be the value of the bit. When SAM = "1," the value of the bit is determined by a majority circuit from three sampled values, each sampled 2 Tq's before, 1 Tq before, and at the end of Phase Segment1.

**Table 13.2.1 Typical Settings of Bit Timing when f(CPUCLK) = 160 MHz (Note 2)**

Baud Rate	BRP Set Value	Tq Period (ns)	No. of Tq's in 1 Bit	PROP + PH1	PH2	Sampling Point	
1M bps	1	50	20	16	3	85% (Note 1)	
				15	4	80% (Note 1)	
				14	5	75% (Note 1)	
	3	100	10	7	2	80%	
				6	3	70%	
				5	4	60%	
	4	125	8	6	1	88%	
				5	2	75%	
				4	3	63%	
	500k bps	3	100	20	16	3	85% (Note 1)
					15	4	80% (Note 1)
					14	5	75% (Note 1)
4		125	16	13	2	88% (Note 1)	
				12	3	81% (Note 1)	
				11	4	75%	
7		200	10	8	1	90%	
				7	2	80%	
				6	3	70%	
9		250	8	6	1	88%	
				5	2	75%	
				4	3	63%	

Note 1: PH2 = max (PH1, IPT), that is specified in CAN protocol, cannot be met.

Note 2: As for Can module clock, select CPUCLK/4 in CAN Clock Select Register.

Note: • It does not mean that the communication at the above baud rate settings is guaranteed. Sufficient evaluation and verification are required before use.

Table 13.2.2 Typical Settings of Bit Timing when f(CPUCLK) = 128 MHz (Note 2)

Baud Rate	BRP Set Value	Tq Period (ns)	No. of Tq's in 1 Bit	PROP + PH1	PH2	Sampling Point
1M bps	1	62.5	16	13	2	88% (Note 1)
				12	3	81% (Note 1)
				11	4	75%
	3	125	8	6	1	88%
				5	2	75%
				4	3	63%
500k bps	3	125	16	12	3	81% (Note 1)
				11	4	75%
				10	5	69%
	7	250	8	6	1	88%
				5	2	75%
				4	3	63%

Note 1: PH2 = max (PH1, IPT), that is specified in CAN protocol, cannot be met.

Note 2: As for Can module clock, select CPUCLK/4 in CAN Clock Select Register.

Note: • It does not mean that the communication at the above baud rate settings is guaranteed. Sufficient evaluation and verification are required before use.

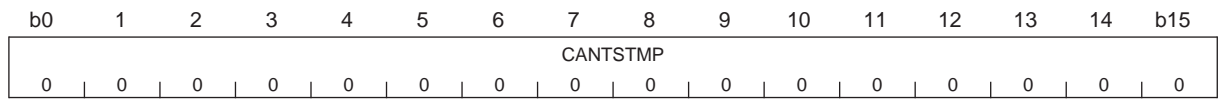
### 13.2.5 CAN Timestamp Count Registers

CAN0 Timestamp Count Register (CAN0TSTMP)

<Address: H'0080 1008>

CAN1 Timestamp Count Register (CAN1TSTMP)

<Address: H'0080 1408>



<Upon exiting reset: H'0000>

b	Bit Name	Function	R	W
0-15	CANTSTMP	16-bit timestamp count value	R	-

The CAN module contains a 16-bit up-count register. The count period can be selected from the CAN bus bit period divided by 1, 2, 3 or 4 by setting the CAN Control Register (CAN0CNT, CAN1CNT) TSP (Timestamp Prescaler) bits. When the CAN module finishes sending or receiving, it captures the count register value and stores the value in a message slot. The counter is made to start counting by clearing the CAN Control Register (CAN0CNT, CAN1CNT) RST bit to "0."

- Notes:
- The CAN protocol control unit can be reset and the counter initialized to H'0000 by setting the CAN Control Register (CAN0CNT, CAN1CNT) RST (CAN Reset) bit to "1." Or the counter can be initialized to H'0000 while the CAN module remains operating by setting the TSR (Timestamp Counter Reset) bit to "1."
  - If any slot with the matching ID exists during loopback mode, the CAN module stores the timestamp value in that slot when it finished receiving. (No timestamp values are stored this way when the CAN module finished sending.)
  - The count period of the CAN Timestamp Count Register varies with the CAN resynchronization function.

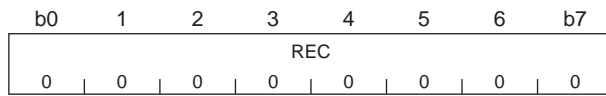
#### 13.2.6 CAN Error Count Registers

CAN0 Receive Error Count Register (CAN0REC)

<Address: H'0080 100A>

CAN1 Receive Error Count Register (CAN1REC)

<Address: H'0080 140A>



<Upon exiting reset: H'00>

b	Bit Name	Function	R	W
0-7	REC	Receive error count value	R	-

During an error active/error passive state, a receive error count value is stored in this register.

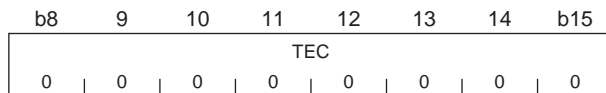
The count is decremented when frames are received normally or incremented when an error occurred. If the CAN module finished receiving normally when  $REC \geq 128$  (error passive), REC is set to 127. During a bus off state, an undefined value is stored in this register. The count is reset to H'00 upon returning to an error active state.

CAN0 Transmit Error Count Register (CAN0TEC)

<Address: H'0080 100B>

CAN1 Transmit Error Count Register (CAN1TEC)

<Address: H'0080 140B>



<Upon exiting reset: H'00>

b	Bit Name	Function	R	W
8-15	TEC	Transmit error count value	R	-

During an error active/error passive state, a transmit error count value is stored in this register.

The count is decremented when frames are transmitted normally or incremented when an error occurred. During a bus off state, an undefined value is stored in this register. The count is reset to H'00 upon returning to an error active state.

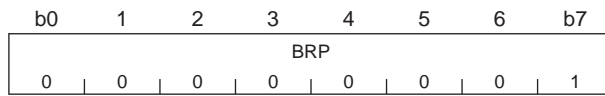
#### 13.2.7 CAN Baud Rate Prescalers

CAN0 Baud Rate Prescaler (CAN0BRP)

<Address: H'0080 1016>

CAN1 Baud Rate Prescaler (CAN1BRP)

<Address: H'0080 1416>



<Upon exiting reset: H'01>

b	Bit Name	Function	R	W
0-7	BRP	CAN baud rate prescaler value	R	W

This register sets the Tq period of CAN. The CAN baud rate is determined by (Tq period × number of Tq's in one bit).

$$Tq \text{ period} = (\text{BRP set value} + 1) / (\text{CPUCLK}/4)$$

$$\text{CAN transfer baud rate} = \frac{1}{Tq \text{ period} \times \text{number of Tq's in one bit}}$$

$$\begin{aligned} \text{Number of Tq's in one bit} = & \text{Synchronization Segment} + \text{Propagation Segment} \\ & + \text{Phase Segment 1} + \text{Phase Segment 2} \end{aligned}$$

Notes: • Setting H'00 (divide by 1) is inhibited.

- Do not change settings of the CAN Baud Rate Prescaler (CANnBRP) during CAN operation (CAN Status Register CRS bit = "0").
- As for Can module clock, select CPUCLK/4 in CAN Clock Select Register.

### 13.2.8 CAN Interrupt Related Registers

The CAN interrupt related registers are used to control the interrupt request signals output to the Interrupt Controller by CAN.

The CAN interrupt request is of 3 types as follows:

- CAN transmit/receive completion interrupt request
- CAN error interrupt request
- CAN single-shot interrupt request

These combined interrupt requests corresponds to CAN transmit/receive & error interrupt request.

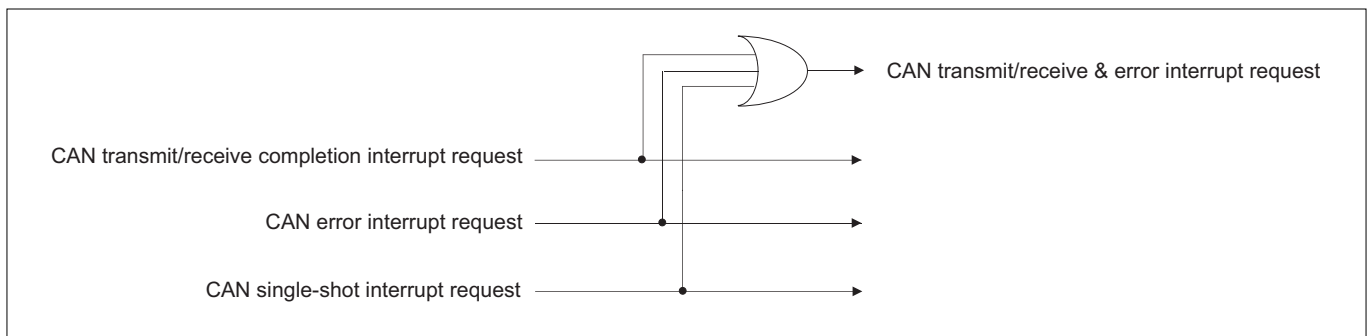


Figure 13.2.3 Block Diagram of the CAN interrupt requests

#### (1) Interrupt request status bit

This status bit is used to determine whether an interrupt is requested. When an interrupt request occurs, this bit is set in hardware (cannot be set in software). The status bit is cleared by writing "0." Writing "1" has no effect; the bit retains the status it had before the write. Because this bit is unaffected by the interrupt request mask bit, it can also be used to inspect the operating status of peripheral functions. In interrupt handling, make sure that within the grouped interrupt request status, only the status bit for the interrupt request that has been serviced is cleared. If the status bit for any interrupt request that has not been serviced is cleared, the pending interrupt request is cleared simultaneously with its status bit.

#### (2) Interrupt request mask bit

This bit is used to disable unnecessary interrupt requests within the grouped interrupt request. Set this bit to "1" to enable interrupt requests or "0" to disable interrupt requests.

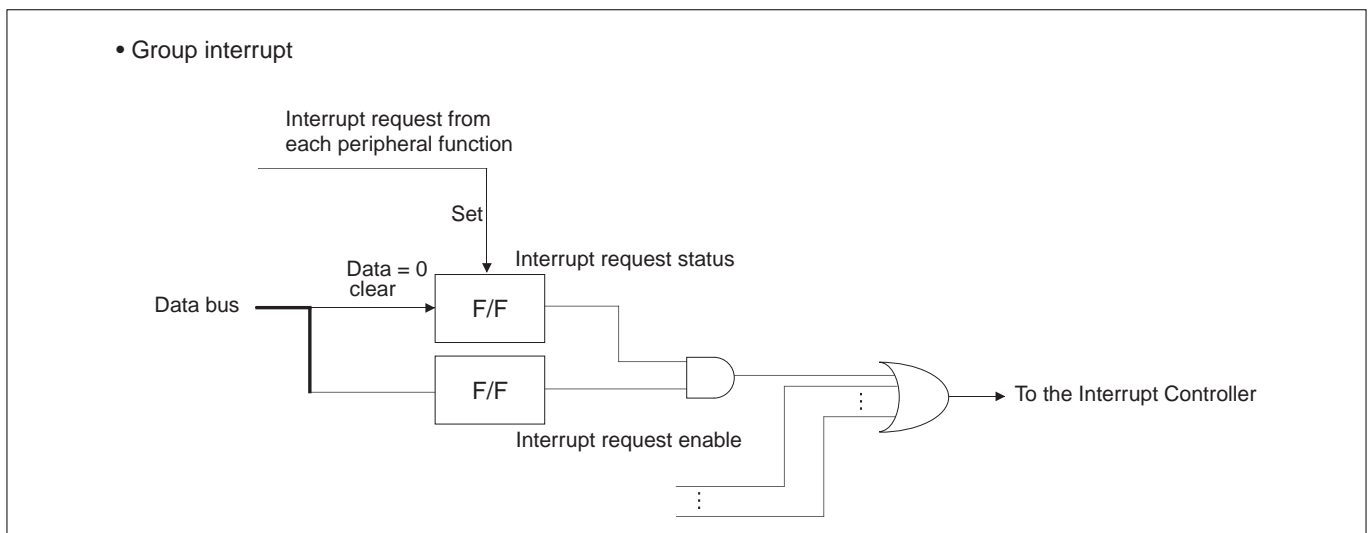
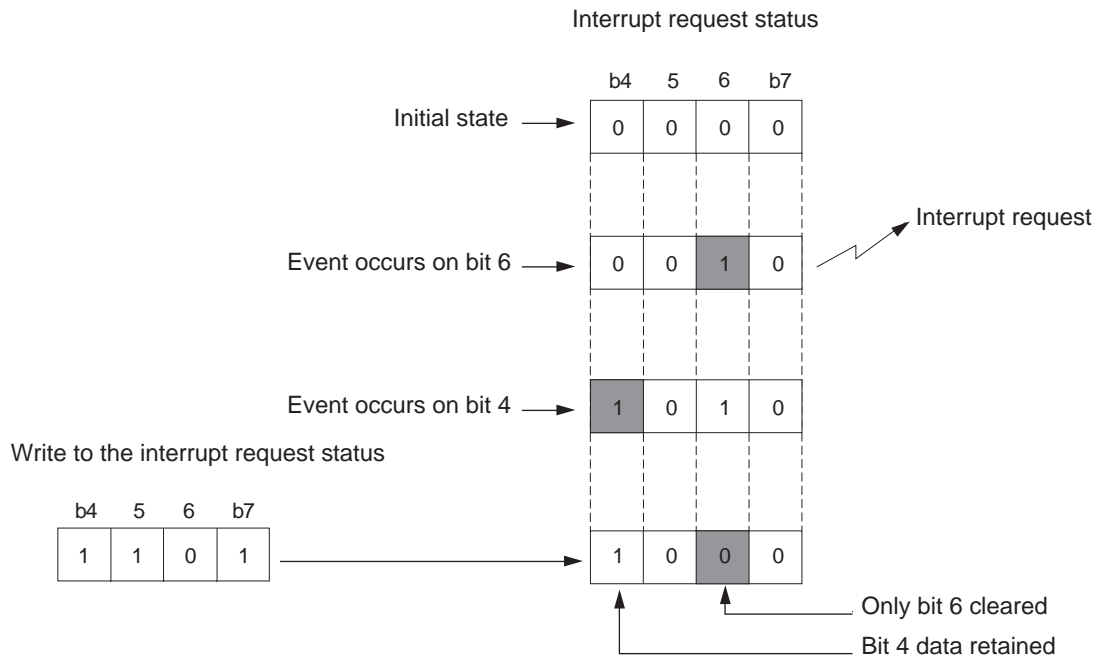


Figure 13.2.4 Interrupt Request Status and Mask Registers



● Example for clearing interrupt request status



● Program example

- To clear the Interrupt Request Status Register 0 (ISTREG) interrupt request status 1, ISTAT1 (0x02 bit)

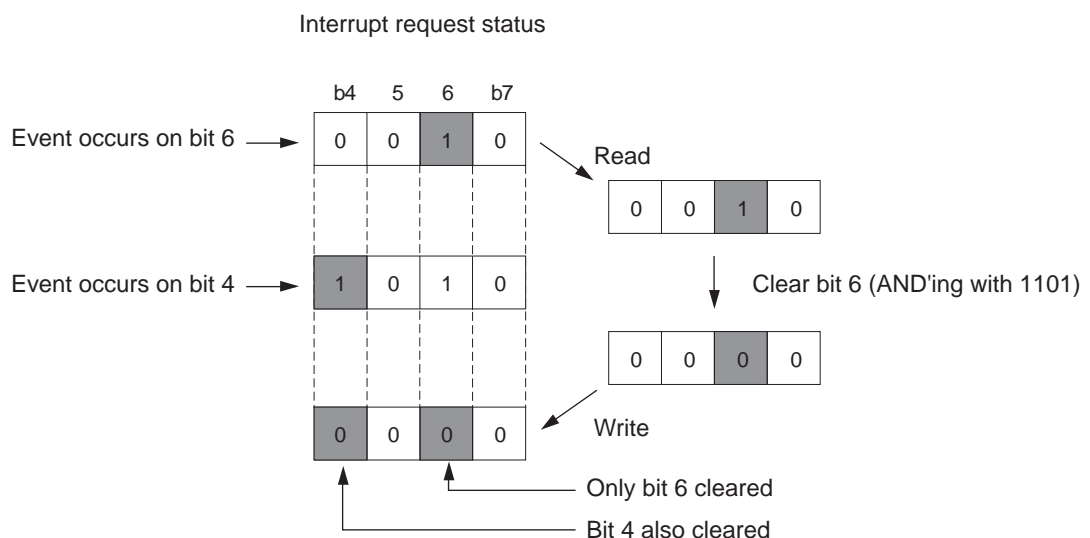


ISTREG = 0xfd; /\* Clear ISTAT1 (0x02 bit) only \*/

To clear an interrupt request status, always be sure to write 1 to all other interrupt request status bits. At this time, avoid using a logic operation like the one shown below. Because it requires three step-ISTREG read, logic operation and write, if another interrupt request occurs between the read and write, status may be inadvertently cleared.



ISTREG &= 0xfd; /\* Clear ISTAT1 (0x02 bit) only \*/



**Figure 13.2.5 Example for Clearing Interrupt Request Status**

CAN0 Slot Interrupt Request Status Register (CAN0SLISTW)

&lt;Address: H'0080 100C&gt;

CAN1 Slot Interrupt Request Status Register (CAN1SLISTW)

&lt;Address: H'0080 140C&gt;

b0	1	2	3	4	5	6	7	8	9	10	11	12	13	14	b15
SSB0	SSB1	SSB2	SSB3	SSB4	SSB5	SSB6	SSB7	SSB8	SSB9	SSB10	SSB11	SSB12	SSB13	SSB14	SSB15
0	0	0	0	0	0	0	0	0	0	0	0	0	0	0	0

b16	17	18	19	20	21	22	23	24	25	26	27	28	29	30	b31
SSB16	SSB17	SSB18	SSB19	SSB20	SSB21	SSB22	SSB23	SSB24	SSB25	SSB26	SSB27	SSB28	SSB29	SSB30	SSB31
0	0	0	0	0	0	0	0	0	0	0	0	0	0	0	0

&lt;Upon exiting reset: H'0000 0000&gt;

b	Bit Name	Function	R	W
0	SSB0 (slot 0 interrupt request status bit)	0: Interrupt not requested		R(Note 1)
1	SSB1 (slot 1 interrupt request status bit)	1: Interrupt requested		
2	SSB2 (slot 2 interrupt request status bit)			
3	SSB3 (slot 3 interrupt request status bit)			
4	SSB4 (slot 4 interrupt request status bit)			
5	SSB5 (slot 5 interrupt request status bit)			
6	SSB6 (slot 6 interrupt request status bit)			
7	SSB7 (slot 7 interrupt request status bit)			
8	SSB8 (slot 8 interrupt request status bit)			
9	SSB9 (slot 9 interrupt request status bit)			
10	SSB10 (slot 10 interrupt request status bit)			
11	SSB11 (slot 11 interrupt request status bit)			
12	SSB12 (slot 12 interrupt request status bit)			
13	SSB13 (slot 13 interrupt request status bit)			
14	SSB14 (slot 14 interrupt request status bit)			
15	SSB15 (slot 15 interrupt request status bit)			
16	SSB16 (slot 16 interrupt request status bit)			
17	SSB17 (slot 17 interrupt request status bit)			
18	SSB18 (slot 18 interrupt request status bit)			
19	SSB19 (slot 19 interrupt request status bit)			
20	SSB20 (slot 20 interrupt request status bit)			
21	SSB21 (slot 21 interrupt request status bit)			
22	SSB22 (slot 22 interrupt request status bit)			
23	SSB23 (slot 23 interrupt request status bit)			
24	SSB24 (slot 24 interrupt request status bit)			
25	SSB25 (slot 25 interrupt request status bit)			
26	SSB26 (slot 26 interrupt request status bit)			
27	SSB27 (slot 27 interrupt request status bit)			
28	SSB28 (slot 28 interrupt request status bit)			
29	SSB29 (slot 29 interrupt request status bit)			
30	SSB30 (slot 30 interrupt request status bit)			
31	SSB31 (slot 31 interrupt request status bit)			

Note 1: Only writing "0" is effective. Writing "1" has no effect; the bit retains the status it had before the write.

When using CAN interrupts, this register helps to know which slot requested an interrupt.

- **Slots set for transmission**

The corresponding bit is set to "1" when the CAN module finished sending. This bit is cleared by writing "0" in software.

- **Slots set for reception**

The corresponding bit is set to "1" when the CAN module finished receiving and finished storing the received message in the message slot. This bit is cleared by writing "0" in software.

When writing to the CAN slot interrupt request status, make sure only the bits to be cleared are set to "0" and all other bits are set to "1." Those bits that have been set to "1" are unaffected by writing in software and retain the value they had before the write.

- Notes:
- If the automatic response function is enabled for remote frame receive slots, the request status is set after the CAN module finished receiving a remote frame and after it finished sending a data frame.
  - For remote frame transmit slots, the request status is set after the CAN module finished sending a remote frame and after it finished receiving a data frame.
  - If the request status is set by an interrupt request at the same time it is cleared in software, the former has priority so that the request status is set.

CAN0 Slot Interrupt Request Mask Register (CAN0SLIMKW)

&lt;Address: H'0080 1010&gt;

CAN1 Slot Interrupt Request Mask Register (CAN1SLIMKW)

&lt;Address: H'0080 1410&gt;

b0	1	2	3	4	5	6	7	8	9	10	11	12	13	14	b15
IRB0	IRB1	IRB2	IRB3	IRB4	IRB5	IRB6	IRB7	IRB8	IRB9	IRB10	IRB11	IRB12	IRB13	IRB14	IRB15
0	0	0	0	0	0	0	0	0	0	0	0	0	0	0	0

b16	17	18	19	20	21	22	23	24	25	26	27	28	29	30	b31
IRB16	IRB17	IRB18	IRB19	IRB20	IRB21	IRB22	IRB23	IRB24	IRB25	IRB26	IRB27	IRB28	IRB29	IRB30	IRB31
0	0	0	0	0	0	0	0	0	0	0	0	0	0	0	0

&lt;Upon exiting reset: H'0000 0000&gt;

b	Bit Name	Function	R	W
0	IRB0 (slot 0 interrupt request mask bit)	0: Mask (disable) interrupt request	R	W
1	IRB1 (slot 1 interrupt request mask bit)	1: Enable interrupt request		
2	IRB2 (slot 2 interrupt request mask bit)			
3	IRB3 (slot 3 interrupt request mask bit)			
4	IRB4 (slot 4 interrupt request mask bit)			
5	IRB5 (slot 5 interrupt request mask bit)			
6	IRB6 (slot 6 interrupt request mask bit)			
7	IRB7 (slot 7 interrupt request mask bit)			
8	IRB8 (slot 8 interrupt request mask bit)			
9	IRB9 (slot 9 interrupt request mask bit)			
10	IRB10 (slot 10 interrupt request mask bit)			
11	IRB11 (slot 11 interrupt request mask bit)			
12	IRB12 (slot 12 interrupt request mask bit)			
13	IRB13 (slot 13 interrupt request mask bit)			
14	IRB14 (slot 14 interrupt request mask bit)			
15	IRB15 (slot 15 interrupt request mask bit)			
16	IRB16 (slot 16 interrupt request mask bit)			
17	IRB17 (slot 17 interrupt request mask bit)			
18	IRB18 (slot 18 interrupt request mask bit)			
19	IRB19 (slot 19 interrupt request mask bit)			
20	IRB20 (slot 20 interrupt request mask bit)			
21	IRB21 (slot 21 interrupt request mask bit)			
22	IRB22 (slot 22 interrupt request mask bit)			
23	IRB23 (slot 23 interrupt request mask bit)			
24	IRB24 (slot 24 interrupt request mask bit)			
25	IRB25 (slot 25 interrupt request mask bit)			
26	IRB26 (slot 26 interrupt request mask bit)			
27	IRB27 (slot 27 interrupt request mask bit)			
28	IRB28 (slot 28 interrupt request mask bit)			
29	IRB29 (slot 29 interrupt request mask bit)			
30	IRB30 (slot 30 interrupt request mask bit)			
31	IRB31 (slot 31 interrupt request mask bit)			

This register is used to enable or disable the interrupt requests that will be generated when data transmission or reception in each corresponding slot is completed. Setting IRB<sub>n</sub> (n = 0–31) to "1" enables the interrupt request to be generated when data transmission or reception in the corresponding slot is completed. The CAN Slot Interrupt Request Status Register (CAN0SLISTW, CAN1SLISTW) helps to know which slot requested the interrupt.

CAN0 Error Interrupt Request Status Register (CAN0ERIST)

&lt;Address: H'0080 1014&gt;

CAN1 Error Interrupt Request Status Register (CAN1ERIST)

&lt;Address: H'0080 1414&gt;

b0	1	2	3	4	5	6	b7
0	0	0	0	0	EIS 0	PIS 0	OIS 0

&lt;Upon exiting reset: H'00&gt;

b	Bit Name	Function	R	W
0-4	No function assigned. Fix to "0."		0	0
5	EIS CAN bus error interrupt request status bit	0: Interrupt not requested 1: Interrupt requested	R	(Note 1)
6	PIS Error passive interrupt request status bit			
7	OIS Bus off interrupt request status bit			

Note 1: Only writing "0" is effective. Writing "1" has no effect; the bit retains the status it had before the write.

When using CAN interrupts, if the interrupt request sources are associated with errors, this register helps to know which source generated the interrupt.

#### (1) EIS (CAN Bus Error Interrupt Request Status) bit (Bit 5)

The EIS bit is set to "1" when a communication error is detected. This bit is cleared by writing "0" in software.

#### (2) PIS (Error Passive Interrupt Request Status) bit (Bit 6)

The PIS bit is set to "1" when the CAN module goes to an error passive state. This bit is cleared by writing "0" in software.

#### (3) OIS (Bus Off Interrupt Request Status) bit (Bit 7)

The OIS bit is set to "1" when the CAN module goes to a bus off passive state. This bit is cleared by writing "0" in software.

When writing to the CAN error interrupt request status, make sure only the bits to be cleared are set to "0" and all other bits are set to "1." Those bits that have been set to "1" are unaffected by writing in software and retain the value they had before the write.

CAN0 Error Interrupt Request Mask Register (CAN0ERIMK)

&lt;Address: H'0080 1015&gt;

CAN1 Error Interrupt Request Mask Register (CAN1ERIMK)

&lt;Address: H'0080 1415&gt;

b8	9	10	11	12	13	14	b15
0	0	0	0	0	EIM 0	PIM 0	OIM 0

&lt;Upon exiting reset: H'00&gt;

b	Bit Name	Function	R	W
8–12	No function assigned. Fix to "0."		0	0
13	EIM CAN bus error interrupt request mask bit	0: Mask (disable) interrupt request 1: Enable interrupt request	R	W
14	PIM Error passive interrupt request mask bit			
15	OIM Bus off interrupt request mask bit			

**(1) EIM (CAN Bus Error Interrupt Request Mask) bit (Bit 13)**

The EIM bit enables or disables the interrupt requests to be generated when CAN bus errors occurred. CAN bus error interrupt requests are enabled by setting this bit to "1."

**(2) PIM (Error Passive Interrupt Request Mask) bit (Bit 14)**

The PIM bit enables or disables the interrupt requests to be generated when the CAN module entered an error passive state. Error passive interrupt requests are enabled by setting this bit to "1."

**(3) OIM (Bus Off Interrupt Request Mask) bit (Bit 15)**

The OIM bit enables or disables the interrupt requests to be generated when the CAN module entered a bus off state. Bus off interrupt requests are enabled by setting this bit to "1."

CAN0 Single-Shot Interrupt Request Status Register (CAN0SSISTW)

<address: H'0080 1044>

CAN1 Single-Shot Interrupt Request Status Register (CAN1SSISTW)

<Address: H'0080 1444>

b0	1	2	3	4	5	6	7	8	9	10	11	12	13	14	b15
SSIST0	SSIST1	SSIST2	SSIST3	SSIST4	SSIST5	SSIST6	SSIST7	SSIST8	SSIST9	SSIST10	SSIST11	SSIST12	SSIST13	SSIST14	SSIST15
0	0	0	0	0	0	0	0	0	0	0	0	0	0	0	0

b16	17	18	19	20	21	22	23	24	25	26	27	28	29	30	b31
SSIST16	SSIST17	SSIST18	SSIST19	SSIST20	SSIST21	SSIST22	SSIST23	SSIST24	SSIST25	SSIST26	SSIST27	SSIST28	SSIST29	SSIST30	SSIST31
0	0	0	0	0	0	0	0	0	0	0	0	0	0	0	0

<Upon exiting reset: H'0000 0000>

b	Bit Name	Function	R	W
0	SSIST0 (slot 0 single-shot interrupt request status bit)	0: No arbitration-lost or transmit error	R	(Note 1)
1	SSIST1 (slot 1 single-shot interrupt request status bit)	1: Arbitration-lost or transmit error occurred		
2	SSIST2 (slot 2 single-shot interrupt request status bit)			
3	SSIST3 (slot 3 single-shot interrupt request status bit)			
4	SSIST4 (slot 4 single-shot interrupt request status bit)			
5	SSIST5 (slot 5 single-shot interrupt request status bit)			
6	SSIST6 (slot 6 single-shot interrupt request status bit)			
7	SSIST7 (slot 7 single-shot interrupt request status bit)			
8	SSIST8 (slot 8 single-shot interrupt request status bit)			
9	SSIST9 (slot 9 single-shot interrupt request status bit)			
10	SSIST10 (slot 10 single-shot interrupt request status bit)			
11	SSIST11 (slot 11 single-shot interrupt request status bit)			
12	SSIST12 (slot 12 single-shot interrupt request status bit)			
13	SSIST13 (slot 13 single-shot interrupt request status bit)			
14	SSIST14 (slot 14 single-shot interrupt request status bit)			
15	SSIST15 (slot 15 single-shot interrupt request status bit)			
16	SSIST16 (slot 16 single-shot interrupt request status bit)			
17	SSIST17 (slot 17 single-shot interrupt request status bit)			
18	SSIST18 (slot 18 single-shot interrupt request status bit)			
19	SSIST19 (slot 19 single-shot interrupt request status bit)			
20	SSIST20 (slot 20 single-shot interrupt request status bit)			
21	SSIST21 (slot 21 single-shot interrupt request status bit)			
22	SSIST22 (slot 22 single-shot interrupt request status bit)			
23	SSIST23 (slot 23 single-shot interrupt request status bit)			
24	SSIST24 (slot 24 single-shot interrupt request status bit)			
25	SSIST25 (slot 25 single-shot interrupt request status bit)			
26	SSIST26 (slot 26 single-shot interrupt request status bit)			
27	SSIST27 (slot 27 single-shot interrupt request status bit)			
28	SSIST28 (slot 28 single-shot interrupt request status bit)			
29	SSIST29 (slot 29 single-shot interrupt request status bit)			
30	SSIST30 (slot 30 single-shot interrupt request status bit)			
31	SSIST31 (slot 31 single-shot interrupt request status bit)			

Note 1: Only writing "0" is effective. Writing "1" has no effect; the bit retains the status it had before the write.

If transmission in any slot failed for reasons of a detection of arbitration-lost or a transmit error during single-shot mode, the corresponding bit in this register is set to "1." The bit is cleared by writing "0" in software.

Furthermore, if the corresponding bit in the CAN single-shot interrupt request mask register has been set to "1," an interrupt request can be generated when transmission failed.

When writing to the CAN single-shot interrupt request status, make sure only the bits to be cleared are set to "0" and all other bits are set to "1." Those bits that have been set to "1" are unaffected by writing in software and retain the value they had before the write.



CAN0 Single-Shot Interrupt Request Mask Register (CAN0SSIMKW)

&lt;Address: H'0080 1048&gt;

CAN1 Single-Shot Interrupt Request Mask Register (CAN1SSIMKW)

&lt;Address: H'0080 1448&gt;

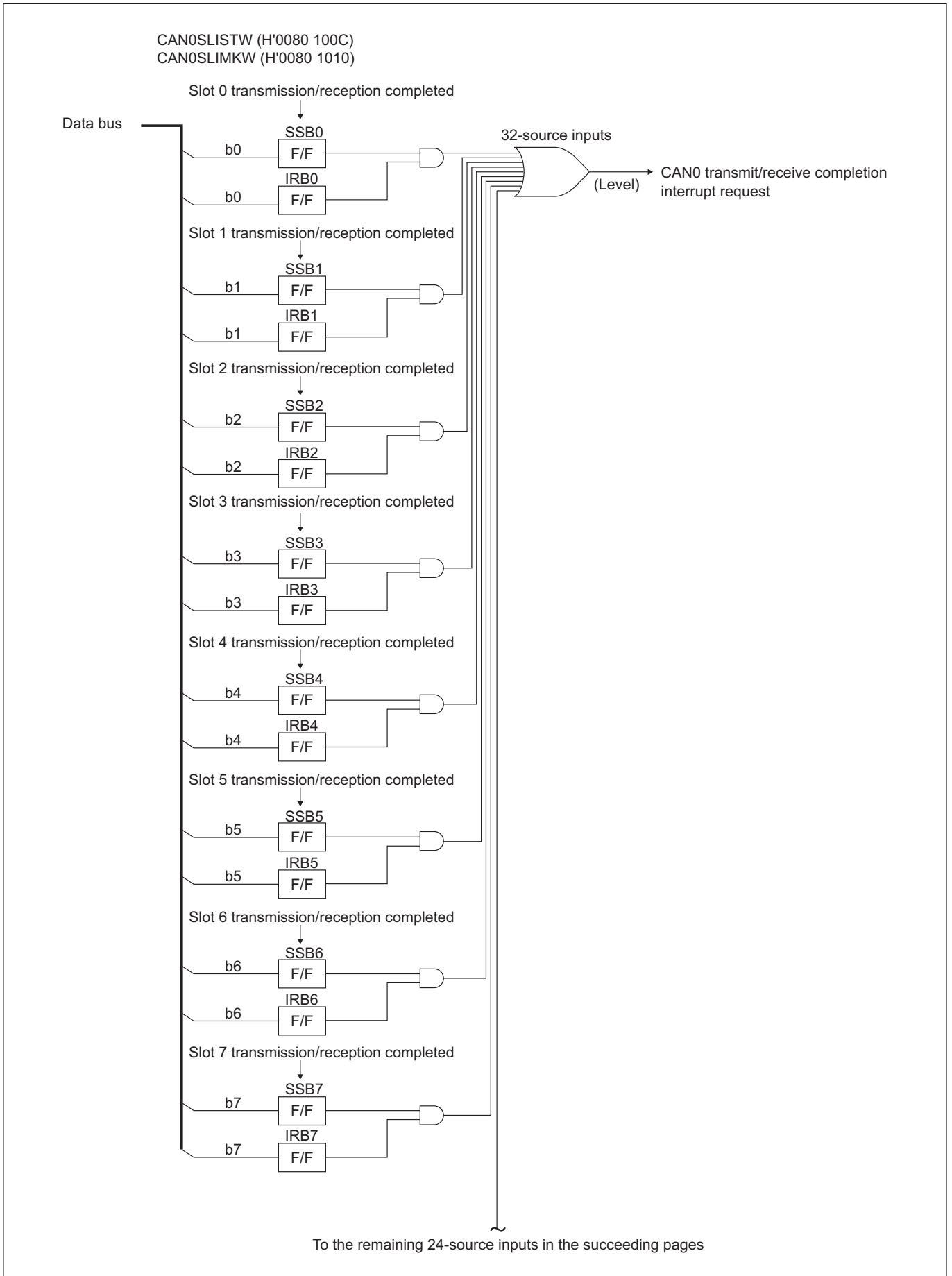
b0	1	2	3	4	5	6	7	8	9	10	11	12	13	14	b15
SSIMK0	SSIMK1	SSIMK2	SSIMK3	SSIMK4	SSIMK5	SSIMK6	SSIMK7	SSIMK8	SSIMK9	SSIMK10	SSIMK11	SSIMK12	SSIMK13	SSIMK14	SSIMK15
0	0	0	0	0	0	0	0	0	0	0	0	0	0	0	0

b16	17	18	19	20	21	22	23	24	25	26	27	28	29	30	b31
SSIMK16	SSIMK17	SSIMK18	SSIMK19	SSIMK20	SSIMK21	SSIMK22	SSIMK23	SSIMK24	SSIMK25	SSIMK26	SSIMK27	SSIMK28	SSIMK29	SSIMK30	SSIMK31
0	0	0	0	0	0	0	0	0	0	0	0	0	0	0	0

&lt;Upon exiting reset: H'0000 0000&gt;

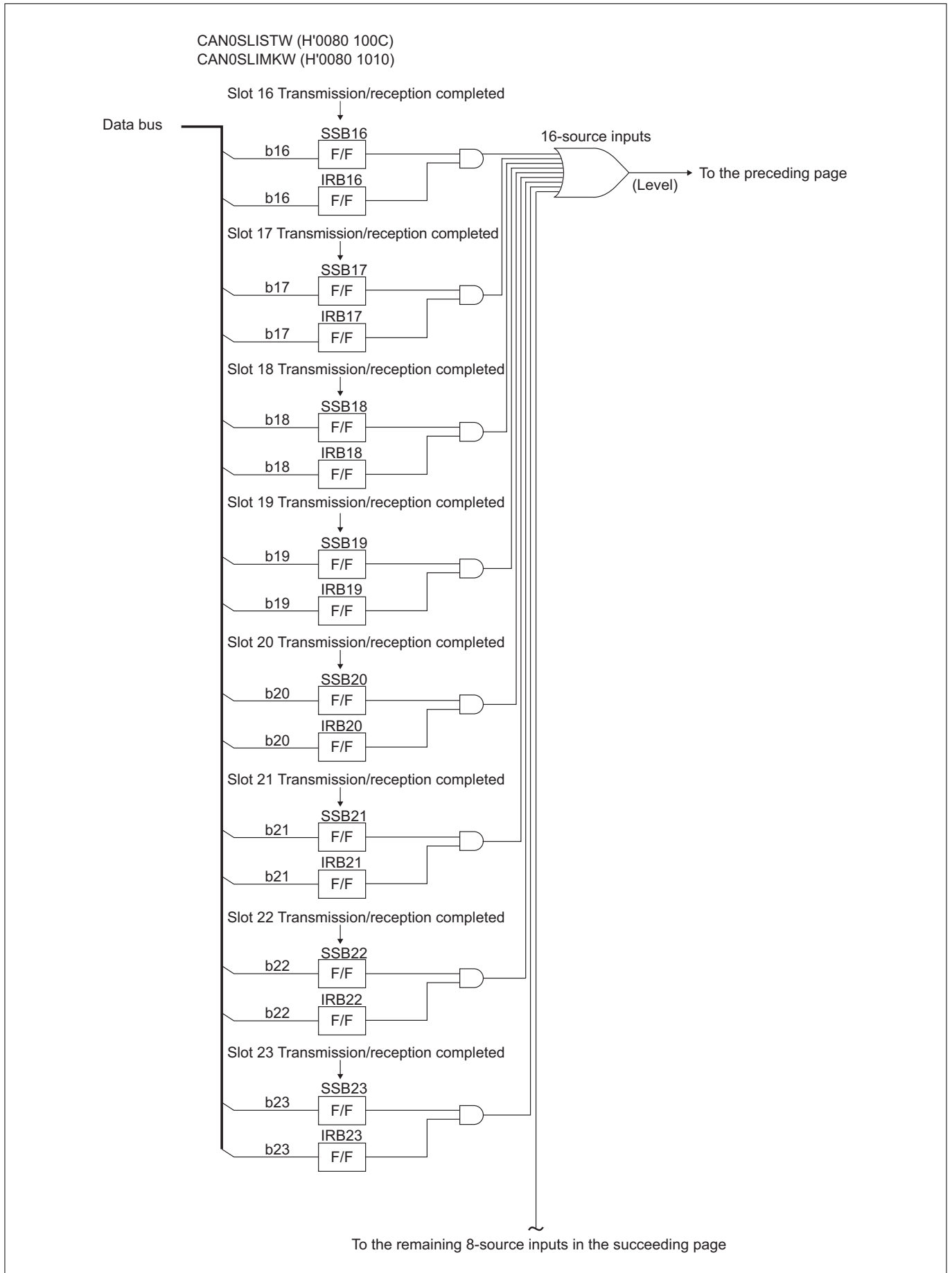
b	Bit Name	Function	R	W
0	SSIMK0 (slot 0 single-shot interrupt request mask bit)	0: Disable interrupt request	R	W
1	SSIMK1 (slot 1 single-shot interrupt request mask bit)	1: Enable interrupt request		
2	SSIMK2 (slot 2 single-shot interrupt request mask bit)			
3	SSIMK3 (slot 3 single-shot interrupt request mask bit)			
4	SSIMK4 (slot 4 single-shot interrupt request mask bit)			
5	SSIMK5 (slot 5 single-shot interrupt request mask bit)			
6	SSIMK6 (slot 6 single-shot interrupt request mask bit)			
7	SSIMK7 (slot 7 single-shot interrupt request mask bit)			
8	SSIMK8 (slot 8 single-shot interrupt request mask bit)			
9	SSIMK9 (slot 9 single-shot interrupt request mask bit)			
10	SSIMK10 (slot 10 single-shot interrupt request mask bit)			
11	SSIMK11 (slot 11 single-shot interrupt request mask bit)			
12	SSIMK12 (slot 12 single-shot interrupt request mask bit)			
13	SSIMK13 (slot 13 single-shot interrupt request mask bit)			
14	SSIMK14 (slot 14 single-shot interrupt request mask bit)			
15	SSIMK15 (slot 15 single-shot interrupt request mask bit)			
16	SSIMK16 (slot 16 single-shot interrupt request mask bit)			
17	SSIMK17 (slot 17 single-shot interrupt request mask bit)			
18	SSIMK18 (slot 18 single-shot interrupt request mask bit)			
19	SSIMK19 (slot 19 single-shot interrupt request mask bit)			
20	SSIMK20 (slot 20 single-shot interrupt request mask bit)			
21	SSIMK21 (slot 21 single-shot interrupt request mask bit)			
22	SSIMK22 (slot 22 single-shot interrupt request mask bit)			
23	SSIMK23 (slot 23 single-shot interrupt request mask bit)			
24	SSIMK24 (slot 24 single-shot interrupt request mask bit)			
25	SSIMK25 (slot 25 single-shot interrupt request mask bit)			
26	SSIMK26 (slot 26 single-shot interrupt request mask bit)			
27	SSIMK27 (slot 27 single-shot interrupt request mask bit)			
28	SSIMK28 (slot 28 single-shot interrupt request mask bit)			
29	SSIMK29 (slot 29 single-shot interrupt request mask bit)			
30	SSIMK30 (slot 30 single-shot interrupt request mask bit)			
31	SSIMK31 (slot 31 single-shot interrupt request mask bit)			

This register is used to enable or disable the interrupt requests that will be generated when transmission in each corresponding slot has failed. Setting any bit in this register to "1" enables the interrupt request to be generated when transmission in the corresponding slot (in single-shot mode only) has failed. The CAN Single-Shot Interrupt Request Status Register helps to know which slot requested the interrupt.



**Figure 13.2.6 Block Diagram of CAN0 Transmit/Receive Completion Interrupt Requests (1/4)**





**Figure 13.2.8 Block Diagram of CAN0 Transmit/Receive Completion Interrupt Requests (3/4)**



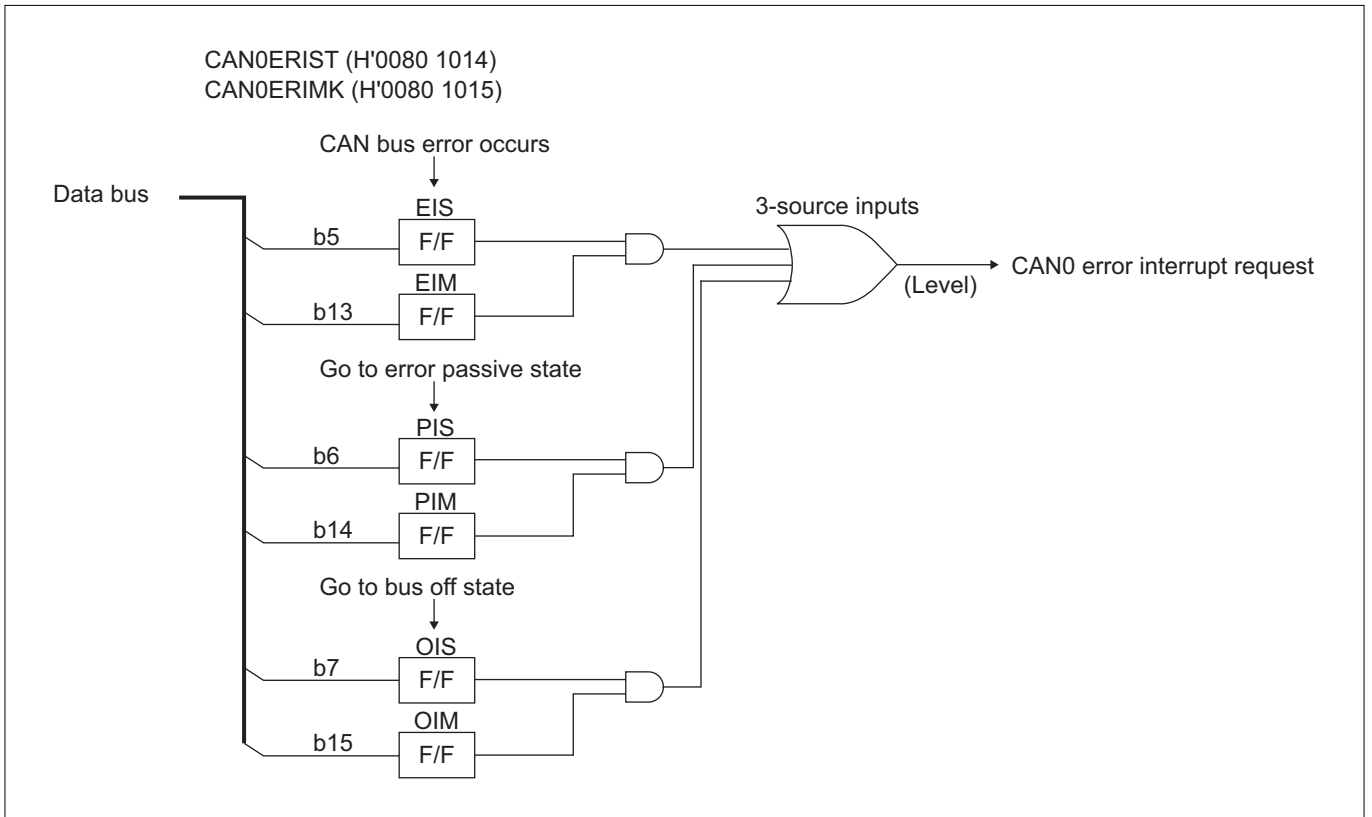
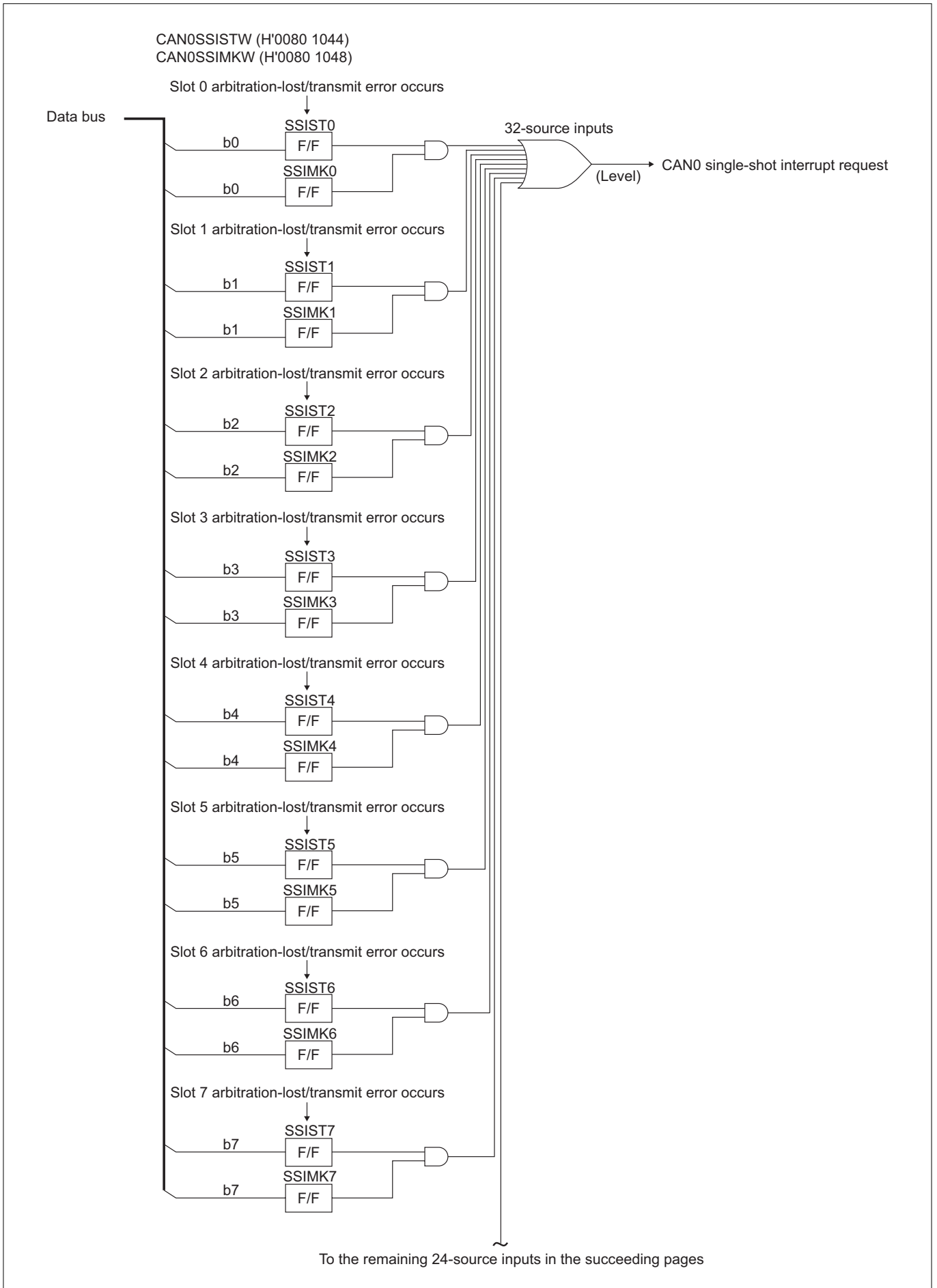
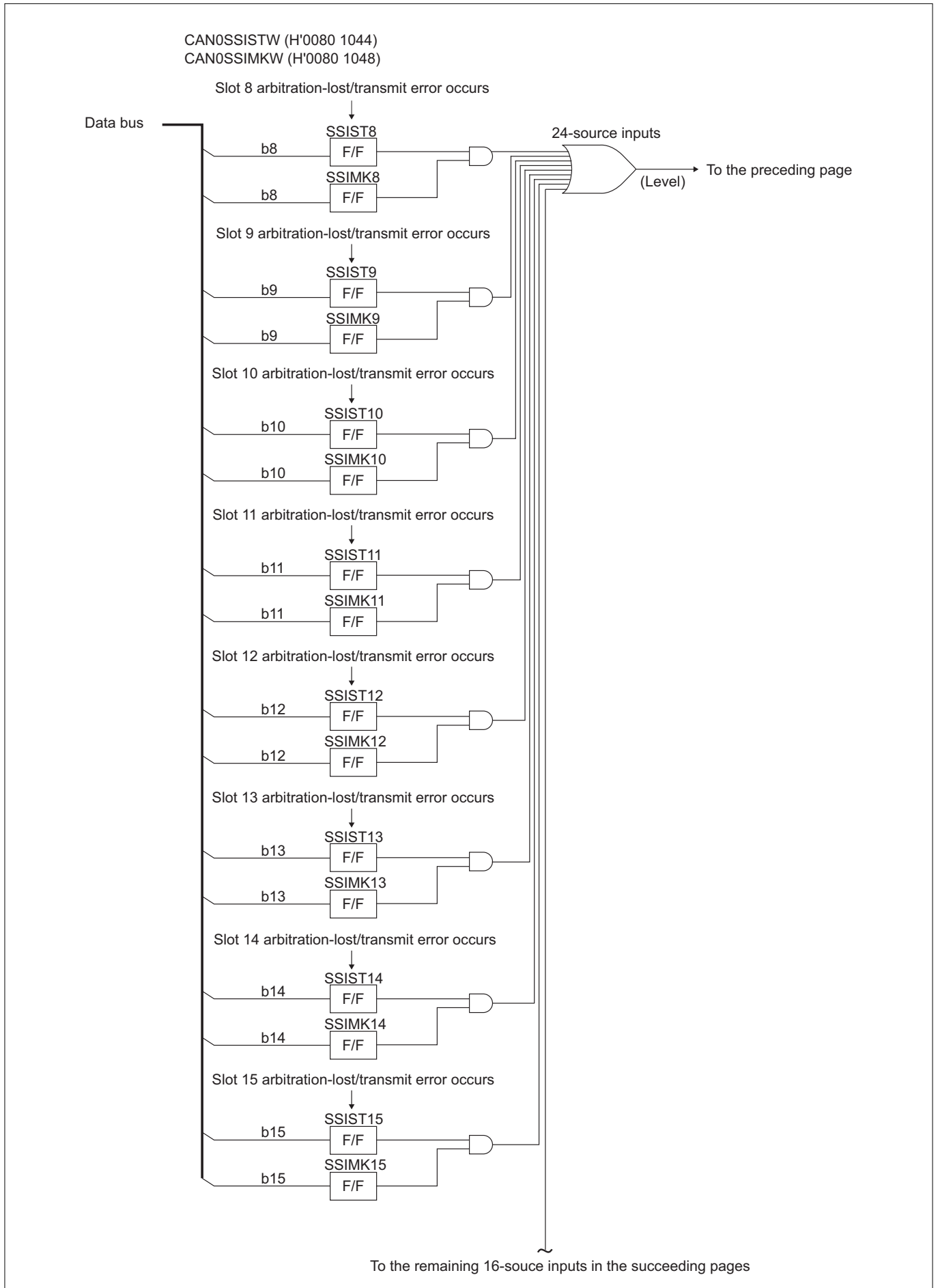


Figure 13.2.10 Block Diagram of CAN0 Error Interrupt Requests

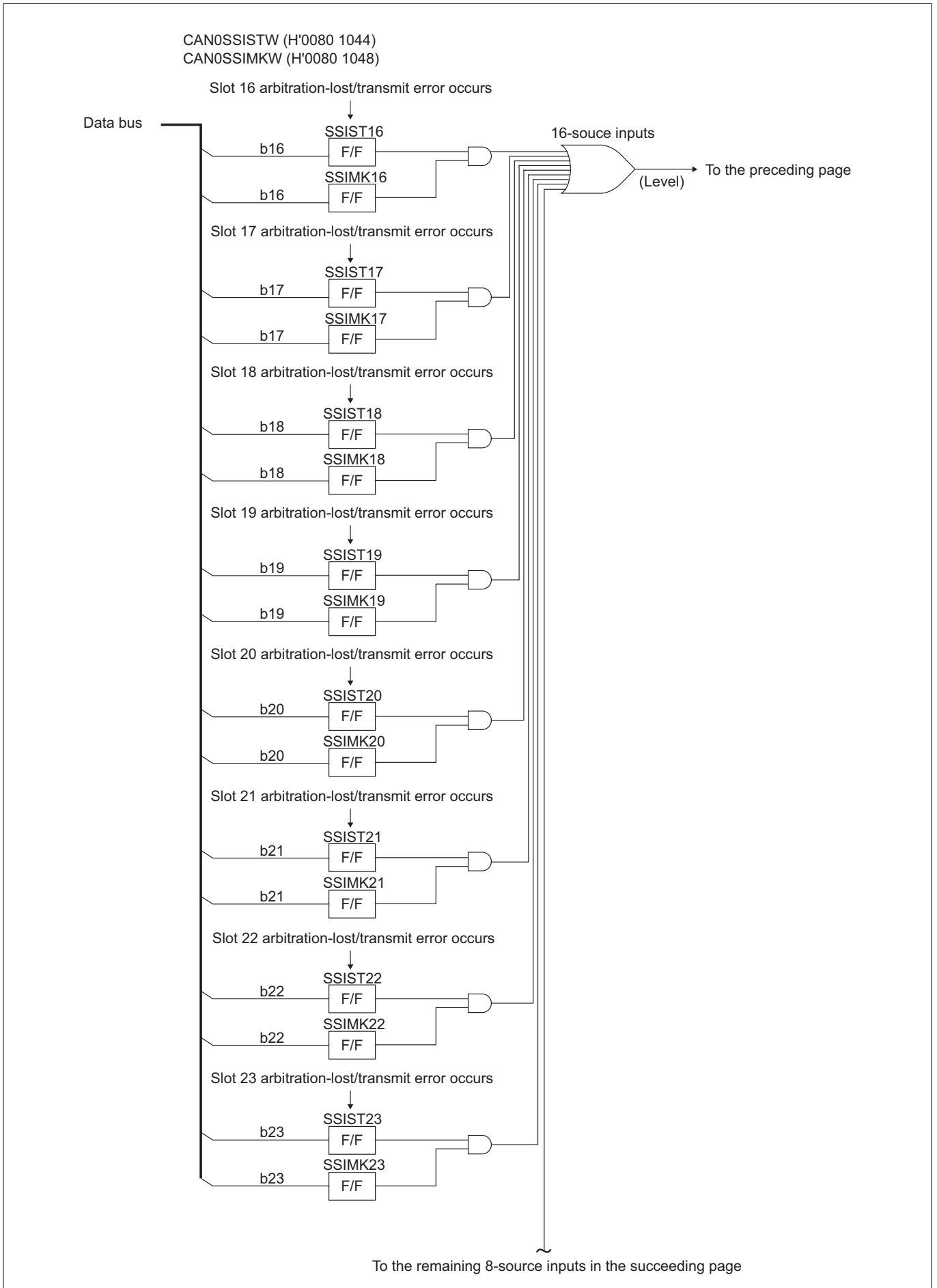


**Figure 13.2.11 Block Diagram of CAN0 Single-shot Interrupt Requests (1/4)**





**Figure 13.2.12 Block Diagram of CAN0 Single-shot Interrupt Requests (2/4)**



**Figure 13.2.13 Block Diagram of CAN0 Single-shot Interrupt Requests (3/4)**

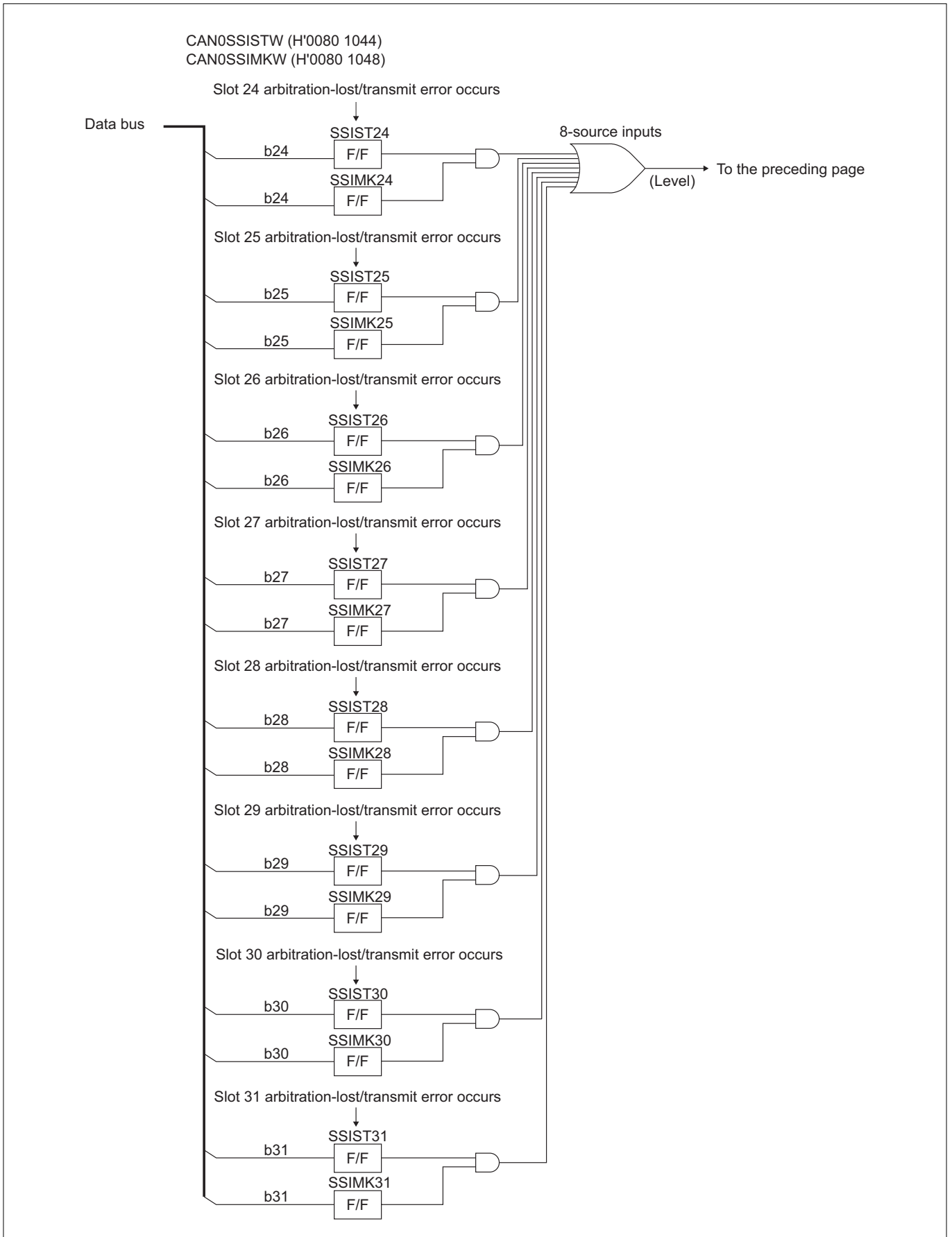
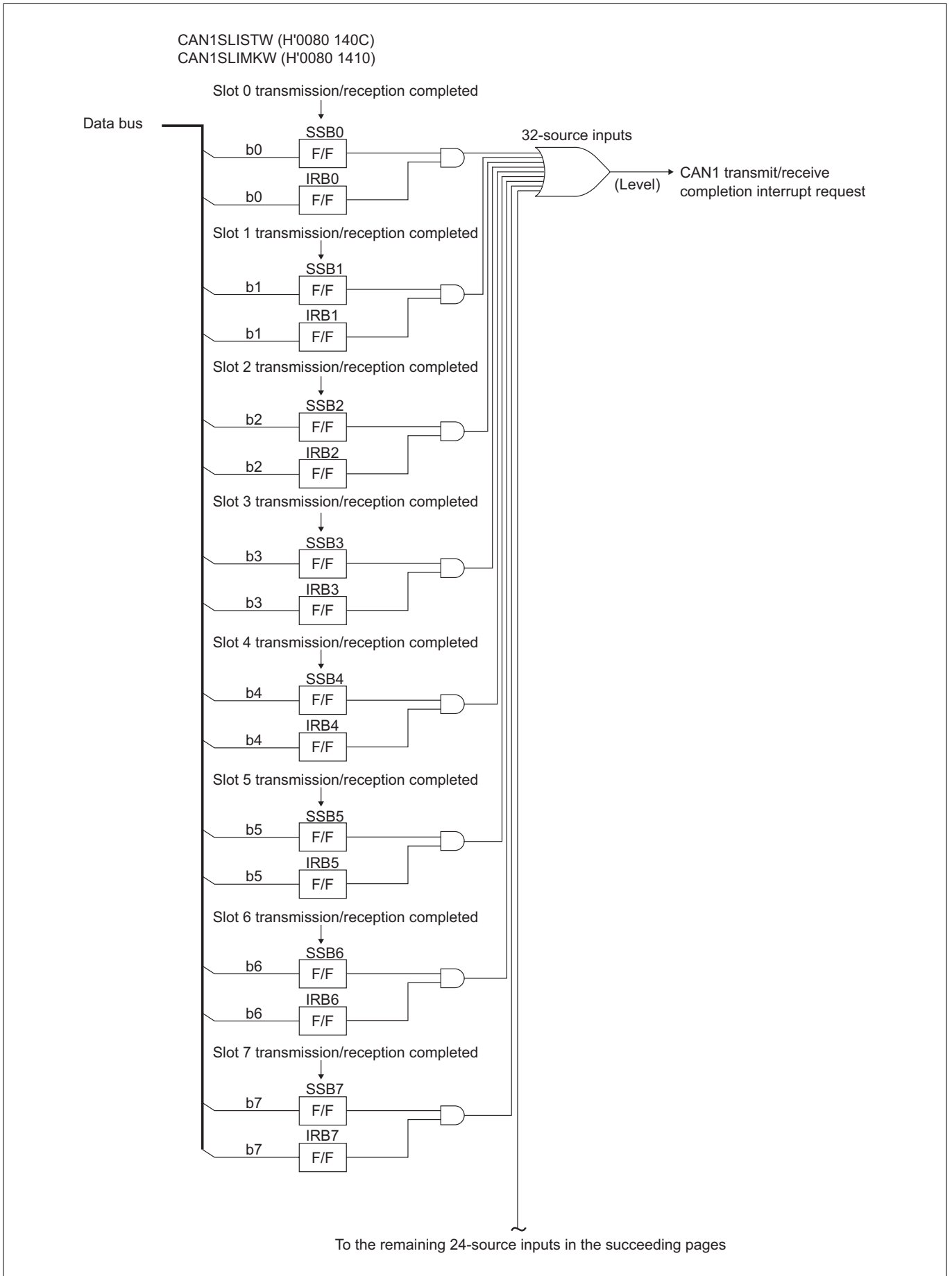


Figure 13.2.14 Block Diagram of CAN0 Single-shot Interrupt Requests (4/4)



**Figure 13.2.15 Block Diagram of CAN1 Transmit/Receive Completion Interrupt Requests (1/4)**





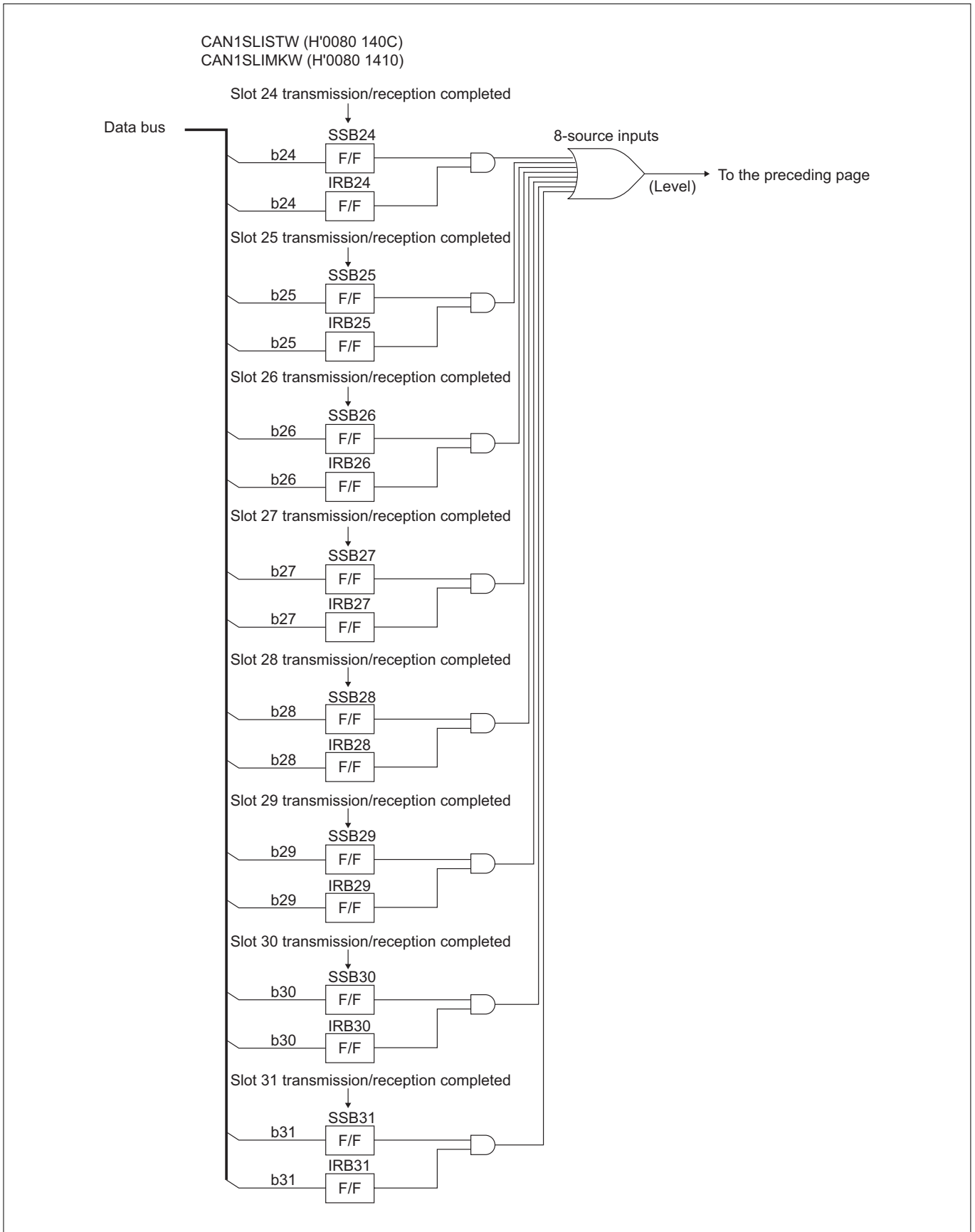


Figure 13.2.18 Block Diagram of CAN1 Transmit/Receive Completion Interrupt Requests (4/4)

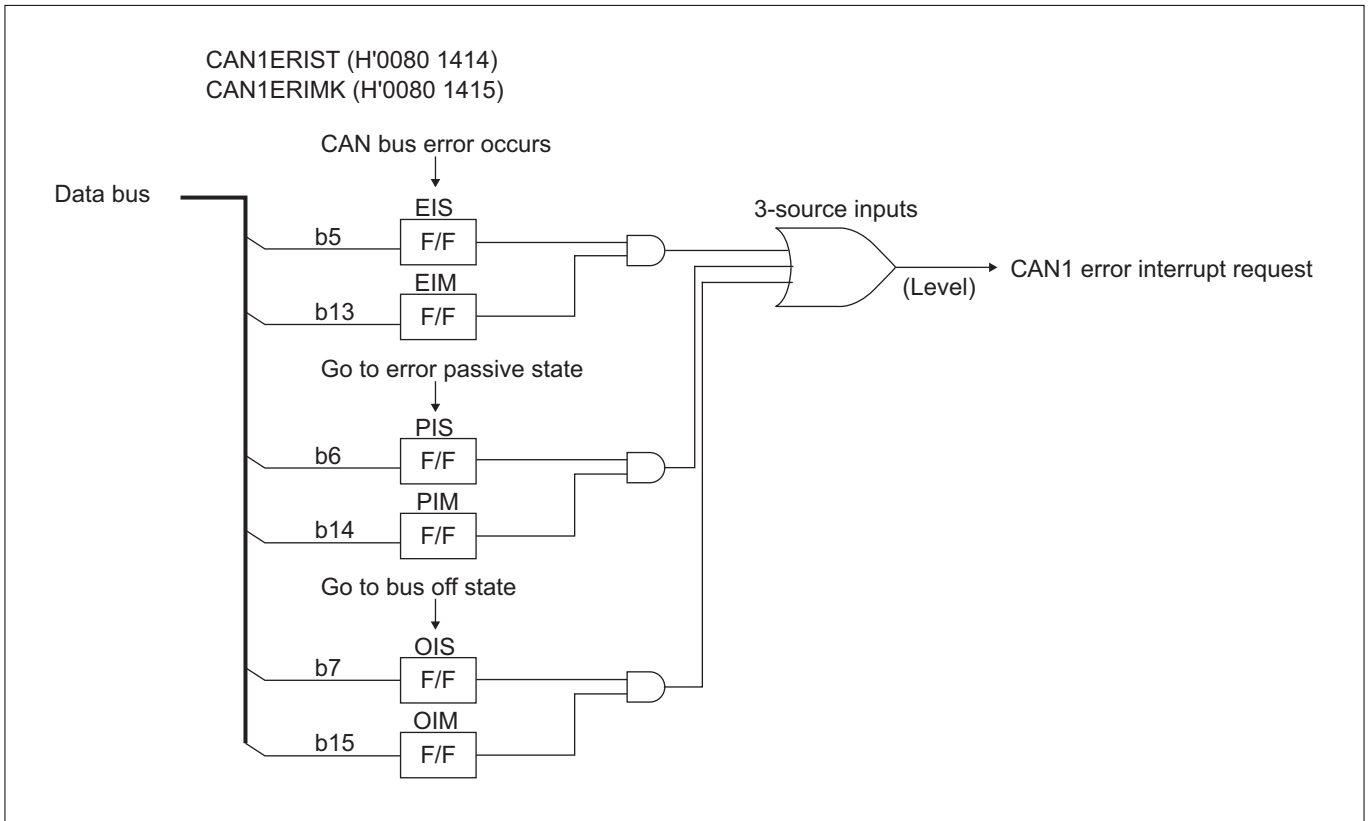
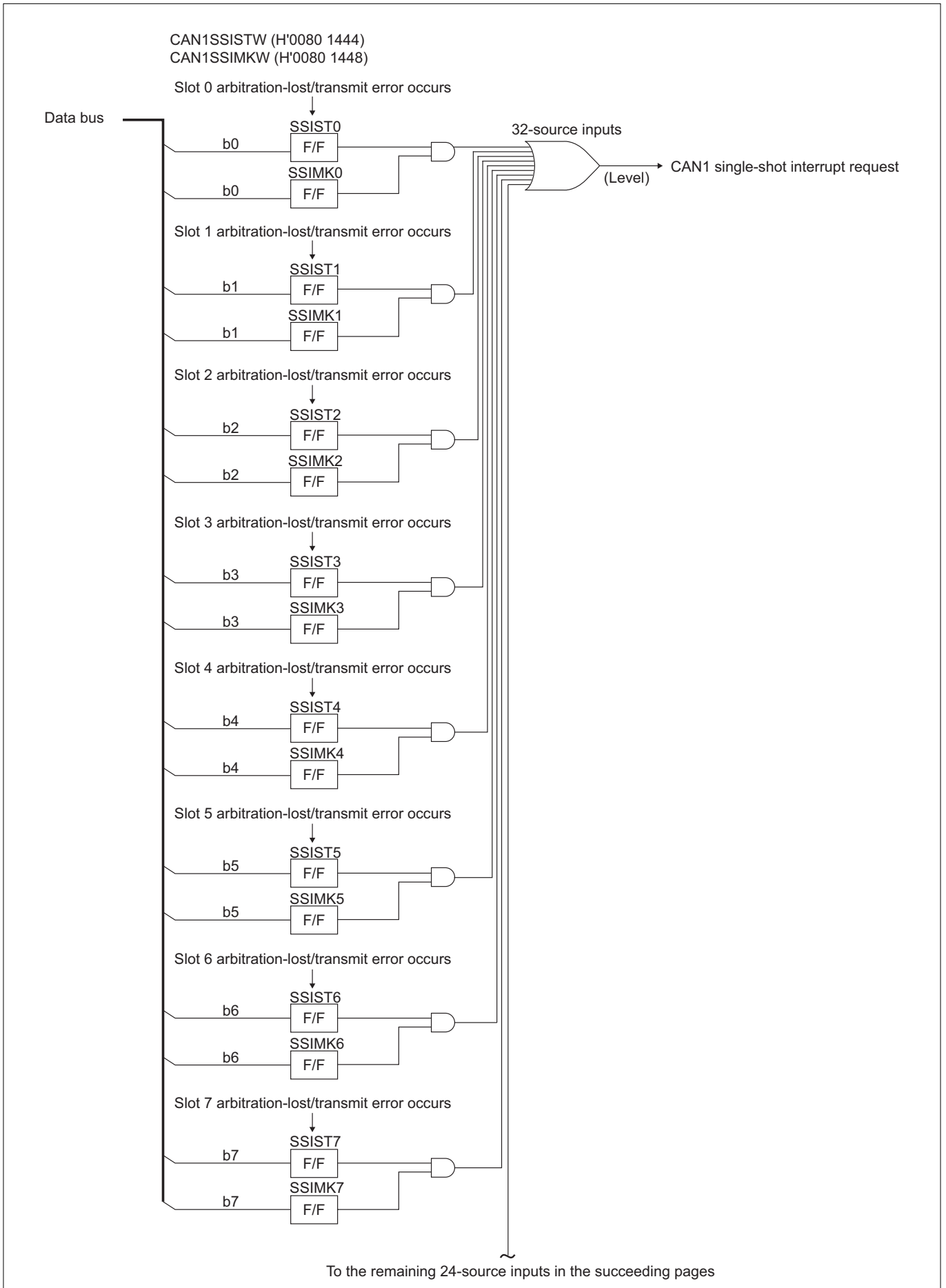
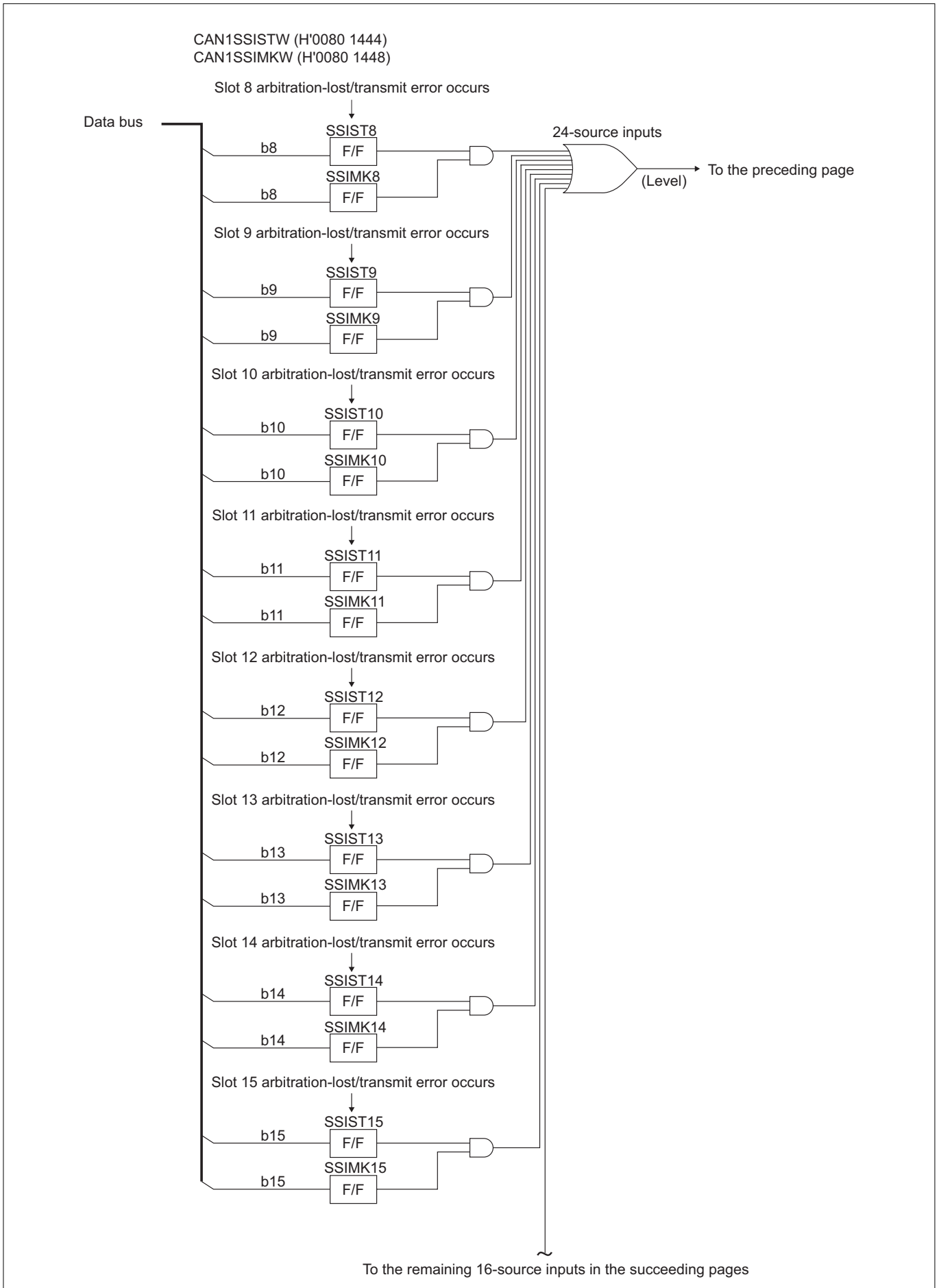


Figure 13.2.19 Block Diagram of CAN1 Error Interrupt Requests

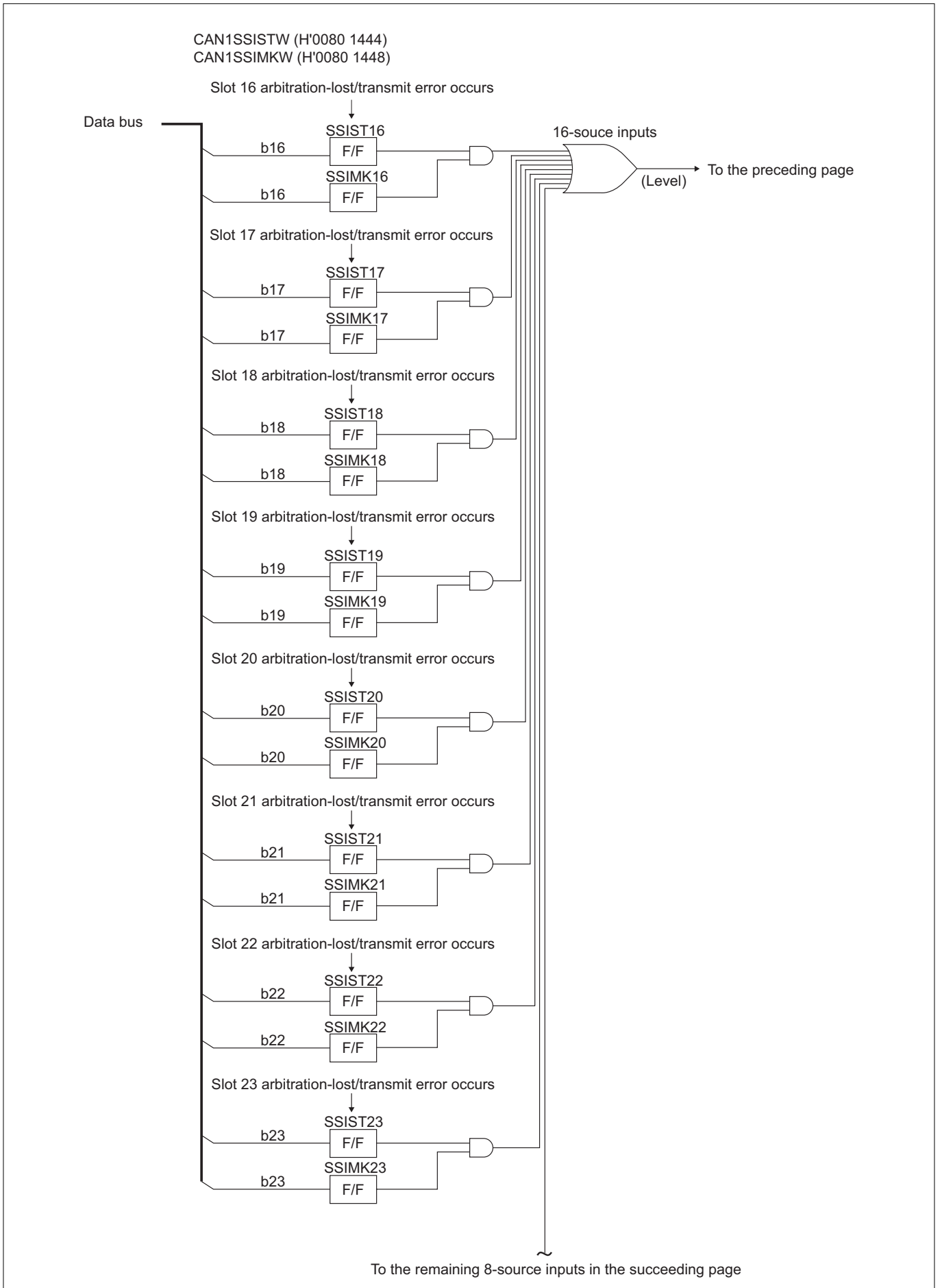




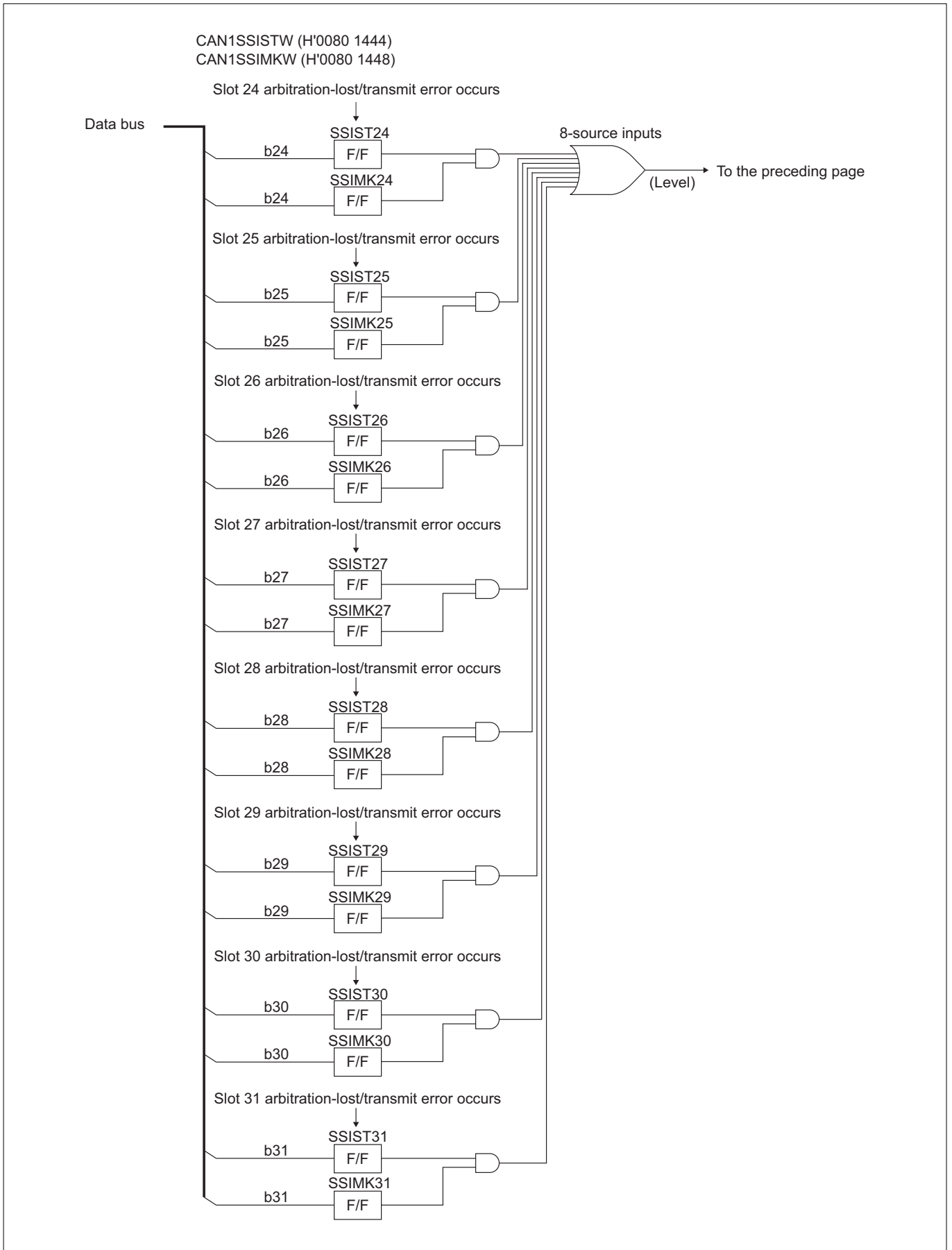
**Figure 13.2.20 Block Diagram of CAN1 Single-shot Interrupt Requests (1/4)**



**Figure 13.2.21 Block Diagram of CAN1 Single-shot Interrupt Requests (2/4)**



**Figure 13.2.22 Block Diagram of CAN1 Single-shot Interrupt Requests (3/4)**



**Figure 13.2.23 Block Diagram of CAN1 Single-shot Interrupt Requests (4/4)**

### 13.2.9 CAN Cause of Error Registers

CAN0 Cause of Error Register (CAN0EF)

<Address: H'0080 1017>

CAN1 Cause of Error Register (CAN1EF)

<Address: H'0080 1417>

b8	9	10	11	12	13	14	b15
TRE	RCVE	BITE0	BITE1	STFE	FORME	CRCE	ACKE
0	0	0	0	0	0	0	0

<Upon exiting reset: H'00>

b	Bit Name	Function	R	W
8	TRE Transmit error detection bit	0: Error not detected 1: Transmit error detected	R (Note 1)	
9	RCVE Receive error detection bit	0: Error not detected 1: Receive error detected	R (Note 1)	
10	BITE0 "0" sending bit error detection bit	0: No bit error is detected 1: Bit error is detected when sending a "0"	R (Note 1)	
11	BITE1 "1" sending bit error detection bit	0: No bit error is detected 1: Bit error is detected when sending a "1"	R (Note 1)	
12	STFE Stuff error detection bit	0: Error not detected 1: Stuff error detected	R (Note 1)	
13	FORME Form error detection bit	0: Error not detected 1: Form error detected	R (Note 1)	
14	CRCE CRC error detection bit	0: Error not detected 1: CRC error detected	R (Note 1)	
15	ACKE ACK error detection bit	0: Error not detected 1: ACK error detected	R (Note 1)	

Note 1: Only writing "0" is effective. Writing "1" has no effect; the bit retains the status it had before the write.

This register indicates error information when a communication error occurred.

Each bit in this register is set every time a communication error is detected, and is not cleared unless a program writes a "0" to the relevant bit.

#### (1) TRE (Transmit Error Detection) bit (Bit 8)

This bit is set to "1" when a communication error is detected while operating as a transmit node. The bit is cleared by writing a "0" in software.

#### (2) RCVE (Receive Error Detection) bit (Bit 9)

This bit is set to "1" when a communication error is detected while operating as a receive node. The bit is cleared by writing a "0" in software.

#### (3) BITE0 ("0" Sending Bit Error Detection) bit (Bit 10)

This bit is set to "1" when a bit error is detected while sending a "0" from CTX. The bit is cleared by writing a "0" in software.

#### (4) BITE1 ("1" Sending Bit Error Detection) bit (Bit 11)

This bit is set to "1" when a bit error is detected while sending a "1" from CTX. The bit is cleared by writing a "0" in software.

**(5) STFE (Stuff Error Detection) bit (Bit 12)**

This bit is set to "1" when a stuff error was detected. The bit is cleared by writing a "0" in software.

**(6) FORME (Form Error Detection) bit (Bit 13)**

This bit is set to "1" when a form error was detected. The bit is cleared by writing a "0" in software.

**(7) CRCE (CRC Error Detection) bit (Bit 14)**

This bit is set to "1" when a CRC error was detected. The bit is cleared by writing a "0" in software.

**(8) ACKE (ACK Error Detection) bit (Bit 15)**

This bit is set to "1" when an ACK error was detected. The bit is cleared by writing a "0" in software

Note: • For the BITE0, BITE1, STFE, FORME, CRCE and ACKE bits, two or more bits may be set at the same time, depending on the error status.

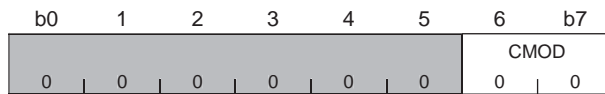
## 13.2.10 CAN Mode Registers

CAN0 Mode Register (CAN0MOD)

&lt;Address: H'0080 1018&gt;

CAN1 Mode Register (CAN1MOD)

&lt;Address: H'0080 1418&gt;



&lt;Upon exiting reset: H'00&gt;

b	Bit Name	Function	R	W
0-5	No function assigned. Fix to "0."		0	0
6-7	CMOD CAN operation mode select bit	00: Normal mode 01: Bus monitor mode 10: Self-diagnostic mode 11: Settings inhibited	R	W

## (1) CMOD (CAN Operation Mode Select) bits (Bits 6, 7)

These bits select the CAN operation mode.

- **Normal operation mode**

Normal transmit/receive operations can be performed.

- **Bus monitor mode**

Only receive operation is performed. During bus monitor mode, the CTX output is fixed "H" and neither ACK nor an error frame can be returned.

Note: • During bus monitor mode, issuing transmit requests is inhibited. The ACK bit is handled as "Don't care" during bus monitor mode. Therefore, if all bits of data including the CRC delimiter are received normally, it is assumed that data has been received normally no matter whether the ACK bit is "H".

- **Self-diagnostic mode**

CTX and CRX are connected together internally in the CAN module. When combined with loopback mode, this mode allows communication to be performed within the CAN module alone. During self-diagnostic mode, the CTX pin output is fixed "H" even when transmitting.

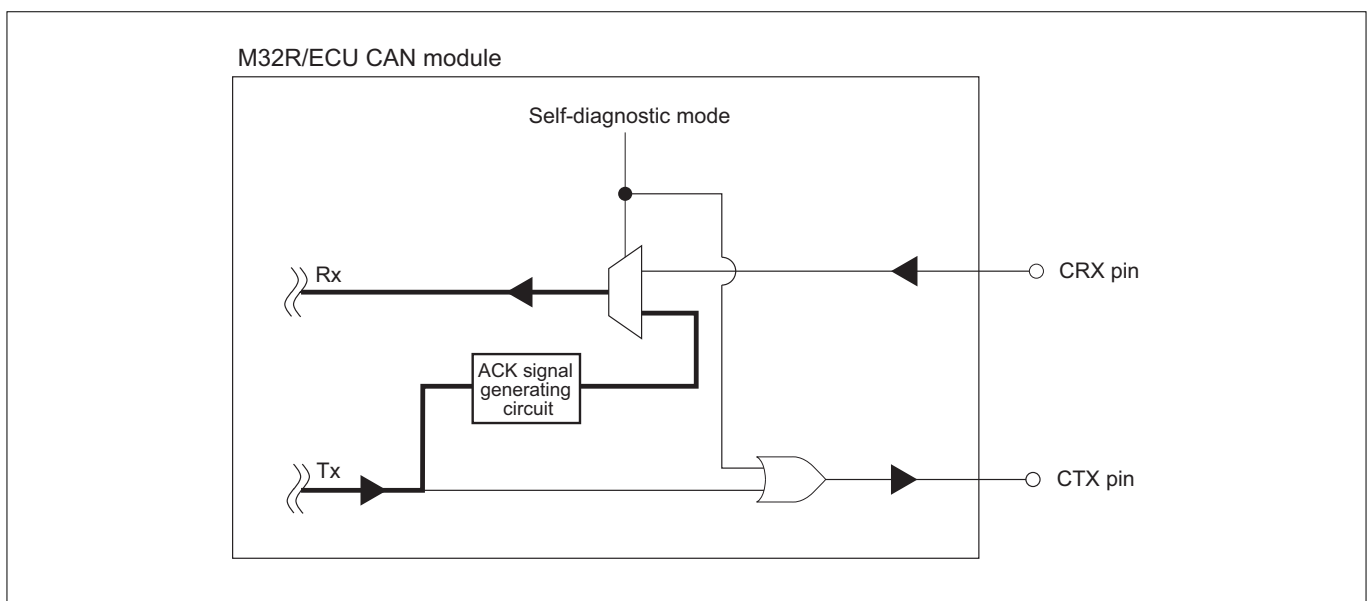


Figure 13.2.24 Conceptual Diagram of Self-Diagnostic Mode

### 13.2.11 CAN DMA Transfer Request Select Registers

CAN0 DMA Transfer Request Select Register (CAN0DMARQ)

<Address: H'0080 1019>

CAN1 DMA Transfer Request Select Register (CAN1DMARQ)

<Address: H'0080 1419>

b8	9	10	11	12	13	14	b15
0	0	0	0	0	0	CDMSEL1	CDMSEL0
0	0	0	0	0	0	0	0

<Upon exiting reset: H'00>

b	Bit Name	Function	R	W
8–13	No function assigned. Fix to "0."		0	0
14	CDMSEL1 CAN DMA1 transfer request source select bit	0: Slot 1 transmission failed 1: Slot 30 transmission/reception completed	R	W
15	CDMSEL0 CAN DMA0 transfer request source select bit	0: Slot 0 transmission failed 1: Slot 31 transmission/reception completed	R	W

CAN0 and 1 can generate DMA transfer requests. This register is used to select the cause or source of that request.

#### (1) CDMSEL1 (CAN DMA1 Transfer Request Source Select) bit (Bit 14)

CAN0 and CAN1 allow DMA2 & DMA7 and DMA7 & DMA9 to generate DMA transfer requests, respectively.

This bit selects one of the following two as the cause or source of a transfer request.

- **Slot 1 transmission failed**

If the CDMSEL1 bit is set to "0," a transfer request is generated when transmission in slot 1 has failed for reasons of arbitration-lost or transmit error.

- **Slot 30 transmission/reception completed**

If the CDMSEL1 bit is set to "1," a transfer request is generated when transmission/reception in slot 30 is completed.

Notes: • If slot 30 has been set for remote frame transmission, a DMA transfer request is generated when remote frame transmission is completed as well as when data frame reception is completed.

- If slot 30 has been set for remote frame reception (automatic response), a DMA transfer request is generated when remote frame reception is completed as well as when data frame transmission is completed.

#### (2) CDMSEL0 (CAN DMA0 Transfer Request Source Select) bit (Bit 15)

CAN0 and CAN1 allow DMA0 & DMA6 and DMA5 & DMA8 to generate DMA transfer requests, respectively.

This bit selects one of the following two as the cause or source of a transfer request.

- **Slot 0 transmission failed**

If the CDMSEL0 bit is set to "0," a transfer request is generated when transmission in slot 0 has failed for reasons of arbitration-lost or transmit error.

- **Slot 31 transmission/reception completed**

If the CDMSEL0 bit is set to "1," a transfer request is generated when transmission/reception in slot 31 is completed.

Notes: • If slot 31 has been set for remote frame transmission, a DMA transfer request is generated when remote frame transmission is completed as well as when data frame reception is completed.

- If slot 31 has been set for remote frame reception (automatic response), a DMA transfer request is generated when remote frame reception is completed as well as when data frame transmission is completed.



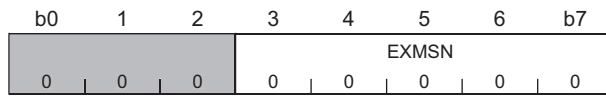
#### 13.2.12 CAN Message Slot Number Registers

CAN0 Message Slot Number Register (CAN0MSN)

<Address: H'0080 101A>

CAN1 Message Slot Number Register (CAN1MSN)

<Address: H'0080 141A>



<Upon exiting reset: H'00>

b	Bit Name	Function	R	W
0-2	No function assigned. Fix to "0."		0	0
3-7	EXMSN Extended message slot number bit	Number of the message slot which has finished sending/receiving 00000: Slot 0   11111: Slot 31	0	-

These bits indicate the relevant slot number when the CAN module has finished sending or finished storing the received data.

These bits cannot be cleared to "0" in software.

Note: • When CAN module receives the frame that is transmitted by the CAN module itself during loopback mode, the EXMSN bits indicate the transmit slot number.

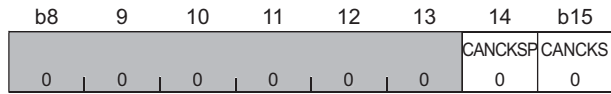
#### 13.2.13 CAN Clock Select Registers

CAN0 Clock Select Register (CAN0CKSEL)

<Address: H'0080 101B>

CAN1 Clock Select Register (CAN1CKSEL)

<Address: H'0080 141B>



<Upon exiting reset: H'00>

b	Bit Name	Function	R	W
8–13	No function assigned. Fix to "0."		0	0
14	CANCKSP CANCKS write control bit		0	W
15	CANCKS CAN module clock select bit	0: CPUCLK/4 clock 1: CPUCLK/2 clock	R	W

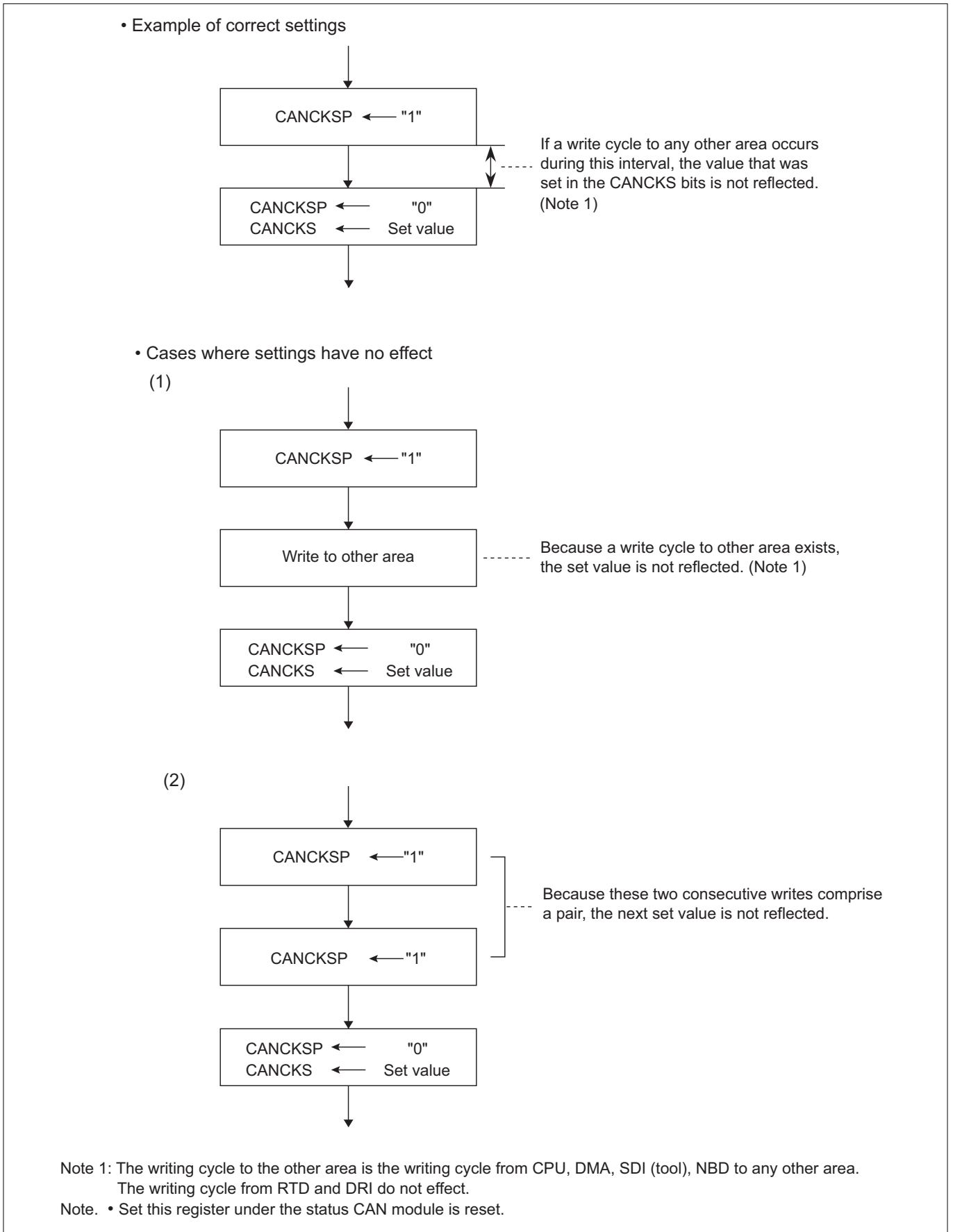
Note: • Use these bits when CANCKS = 0 (CPUCLK/4 clock selection). The operation when CANCKS = 1 (CPUCLK/2 clock selection) is not guaranteed.

These registers switch the clock supplied to the protocol engine block of CAN module.

To set these registers, follow the procedure described below.

1. Confirm the status CAN module is reset.
2. Write a "1" to CANCKSP (CANCKS write control) bit.
3. Subsequent to 2 above, write a "0" to CANCKSP (CANCKS write control) bit and a "set value" to CANCKS (CAN module clock select) bit.

Note: • If there are writing cycles from CPU, DMA, SDI (tool), NBD to any other area between 2 and 3, the continuous setting (A pair of two consecutive is 1 set for writing operation) is disabled and the writing value is not reflected. Therefore, disable interrupts and DMA transfers before setting. However the writing cycle from RTD and DRI are not effected.



**Figure 13.2.25 CANCKS Setting Procedure**

#### 13.2.14 CAN Frame Format Select Registers

CAN0 Frame Format Select Register (CAN0FFSW)

<Address: H'0080 101C>

CAN1 Frame Format Select Register (CAN1FFSW)

<Address: H'0080 141C>

b0	1	2	3	4	5	6	7	8	9	10	11	12	13	14	b15
IDE0	IDE1	IDE2	IDE3	IDE4	IDE5	IDE6	IDE7	IDE8	IDE9	IDE10	IDE11	IDE12	IDE13	IDE14	IDE15
0	0	0	0	0	0	0	0	0	0	0	0	0	0	0	0

b16	17	18	19	20	21	22	23	24	25	26	27	28	29	30	b31
IDE16	IDE17	IDE18	IDE19	IDE20	IDE21	IDE22	IDE23	IDE24	IDE25	IDE26	IDE27	IDE28	IDE29	IDE30	IDE31
0	0	0	0	0	0	0	0	0	0	0	0	0	0	0	0

<Upon exiting reset: H'0000 0000 >

b	Bit Name	Function	R	W
0	IDE0 (frame format 0 select bit)	0: Standard ID format	R	W
1	IDE1 (frame format 1 select bit)	1: Extended ID format		
2	IDE2 (frame format 2 select bit)			
3	IDE3 (frame format 3 select bit)			
4	IDE4 (frame format 4 select bit)			
5	IDE5 (frame format 5 select bit)			
6	IDE6 (frame format 6 select bit)			
7	IDE7 (frame format 7 select bit)			
8	IDE8 (frame format 8 select bit)			
9	IDE9 (frame format 9 select bit)			
10	IDE10 (frame format 10 select bit)			
11	IDE11 (frame format 11 select bit)			
12	IDE12 (frame format 12 select bit)			
13	IDE13 (frame format 13 select bit)			
14	IDE14 (frame format 14 select bit)			
15	IDE15 (frame format 15 select bit)			
16	IDE16 (frame format 16 select bit)			
17	IDE17 (frame format 17 select bit)			
18	IDE18 (frame format 18 select bit)			
19	IDE19 (frame format 19 select bit)			
20	IDE20 (frame format 20 select bit)			
21	IDE21 (frame format 21 select bit)			
22	IDE22 (frame format 22 select bit)			
23	IDE23 (frame format 23 select bit)			
24	IDE24 (frame format 24 select bit)			
25	IDE25 (frame format 25 select bit)			
26	IDE26 (frame format 26 select bit)			
27	IDE27 (frame format 27 select bit)			
28	IDE28 (frame format 28 select bit)			
29	IDE29 (frame format 29 select bit)			
30	IDE30 (frame format 30 select bit)			
31	IDE31 (frame format 31 select bit)			

Select a format of the frame handled in the message slot corresponding to each bit.

When "0" is set, the standard (Standard ID) format is selected.

When "1" is set, the extended (Extended ID) format is selected.

Note: • Change each bit of this register always with the transmit/receive request of the corresponding slot not issued.

### 13.2.15 CAN Mask Registers

CAN0 Global Mask Register A Standard ID0 (C0GMSKAS0)	<Address: H'0080 1020>
CAN0 Global Mask Register B Standard ID0 (C0GMSKBS0)	<Address: H'0080 1028>
CAN0 Local Mask Register A Standard ID0 (C0LMSKAS0)	<Address: H'0080 1030>
CAN0 Local Mask Register B Standard ID0 (C0LMSKBS0)	<Address: H'0080 1038>

CAN1 Global Mask Register A Standard ID0 (C1GMSKAS0)	<Address: H'0080 1420>
CAN1 Global Mask Register B Standard ID0 (C1GMSKBS0)	<Address: H'0080 1428>
CAN1 Local Mask Register A Standard ID0 (C1LMSKAS0)	<Address: H'0080 1430>
CAN1 Local Mask Register B Standard ID0 (C1LMSKBS0)	<Address: H'0080 1438>

b0	1	2	3	4	5	6	b7
0	0	0	SID0M	SID1M	SID2M	SID3M	SID4M
0	0	0	0	0	0	0	0

&lt;Upon exiting reset: H'00&gt;

b	Bit Name	Function	R	W
0-2	No function assigned. Fix to "0."		0	0
3-7	SID0M-SID4M (Standard mask ID0-standard mask ID4)	0: ID not checked 1: ID checked	R	W

CAN0 Global Mask Register A Standard ID1 (C0GMSKAS1)	<Address: H'0080 1021>
CAN0 Global Mask Register B Standard ID1 (C0GMSKBS1)	<Address: H'0080 1029>
CAN0 Local Mask Register A Standard ID1 (C0LMSKAS1)	<Address: H'0080 1031>
CAN0 Local Mask Register B Standard ID1 (C0LMSKBS1)	<Address: H'0080 1039>

CAN1 Global Mask Register A Standard ID1 (C1GMSKAS1)	<Address: H'0080 1421>
CAN1 Global Mask Register B Standard ID1 (C1GMSKBS1)	<Address: H'0080 1429>
CAN1 Local Mask Register A Standard ID1 (C1LMSKAS1)	<Address: H'0080 1431>
CAN1 Local Mask Register B Standard ID1 (C1LMSKBS1)	<Address: H'0080 1439>

b8	9	10	11	12	13	14	b15
0	0	SID5M	SID6M	SID7M	SID8M	SID9M	SID10M
0	0	0	0	0	0	0	0

&lt;Upon exiting reset: H'00&gt;

b	Bit Name	Function	R	W
8-9	No function assigned. Fix to "0."		0	0
10-15	SID5M-SID10M (Standard mask ID5-standard mask ID10)	0: ID not checked 1: ID checked	R	W

Four mask registers are used in acceptance filtering: global mask register A, global mask register B, local mask register A and local mask register B. The global mask registers A and B are used for message slots 0-15 and 16-29, while local mask registers A and B are used for message slots 30 and 31, respectively.

- If any bit in this register is set to "0," the corresponding ID bit is masked (assumed to have matched) during acceptance filtering.
- If any bit in this register is set to "1," the corresponding ID bit is compared with the receive ID during acceptance filtering and when it matches the ID set in the message slot, the received data is stored in it.

- Notes:
- SID0M corresponds to the MSB of the standard ID.
    - The global mask register A can only be modified when none of slots 0-15 have receive requests set.
    - The global mask register B can only be modified when none of slots 16-29 have receive requests set.
    - The local mask register A can only be modified when slot 30 does not have a receive request set.
    - The local mask register B can only be modified when slot 31 does not have a receive request set.

CAN0 Global Mask Register A Extended ID0 (C0GMSKAE0)	<Address: H'0080 1022>
CAN0 Global Mask Register B Extended ID0 (C0GMSKBE0)	<Address: H'0080 102A>
CAN0 Local Mask Register A Extended ID0 (C0LMSKAE0)	<Address: H'0080 1032>
CAN0 Local Mask Register B Extended ID0 (C0LMSKBE0)	<Address: H'0080 103A>
CAN1 Global Mask Register A Extended ID0 (C1GMSKAE0)	<Address: H'0080 1422>
CAN1 Global Mask Register B Extended ID0 (C1GMSKBE0)	<Address: H'0080 142A>
CAN1 Local Mask Register A Extended ID0 (C1LMSKAE0)	<Address: H'0080 1432>
CAN1 Local Mask Register B Extended ID0 (C1LMSKBE0)	<Address: H'0080 143A>

b0	1	2	3	4	5	6	b7
				EID0M	EID1M	EID2M	EID3M
0				0	0	0	0

&lt;Upon exiting reset: H'00&gt;

b	Bit Name	Function	R	W
0–3	No function assigned. Fix to "0."		0	0
4–7	EID0M–EID3M (Extended mask ID0–extended mask ID3)	0: ID not checked 1: ID checked	R	W

CAN0 Global Mask Register A Extended ID1 (C0GMSKAE1)	<Address: H'0080 1023>
CAN0 Global Mask Register B Extended ID1 (C0GMSKBE1)	<Address: H'0080 102B>
CAN0 Local Mask Register A Extended ID1 (C0LMSKAE1)	<Address: H'0080 1033>
CAN0 Local Mask Register B Extended ID1 (C0LMSKBE1)	<Address: H'0080 103B>
CAN1 Global Mask Register A Extended ID1 (C1GMSKAE1)	<Address: H'0080 1423>
CAN1 Global Mask Register B Extended ID1 (C1GMSKBE1)	<Address: H'0080 142B>
CAN1 Local Mask Register A Extended ID1 (C1LMSKAE1)	<Address: H'0080 1433>
CAN1 Local Mask Register B Extended ID1 (C1LMSKBE1)	<Address: H'0080 143B>

b8	9	10	11	12	13	14	b15
EID4M	EID5M	EID6M	EID7M	EID8M	EID9M	EID10M	EID11M
0	0	0	0	0	0	0	0

&lt;Upon exiting reset: H'00&gt;

b	Bit Name	Function	R	W
8–15	EID4M–EID11M (Extended mask ID4–extended mask ID11)	0: ID not checked 1: ID checked	R	W

CAN0 Global Mask Register A Extended ID2 (C0GMSKAE2)	<Address: H'0080 1024>
CAN0 Global Mask Register B Extended ID2 (C0GMSKBE2)	<Address: H'0080 102C>
CAN0 Local Mask Register A Extended ID2 (C0LMSKAE2)	<Address: H'0080 1034>
CAN0 Local Mask Register B Extended ID2 (C0LMSKBE2)	<Address: H'0080 103C>
CAN1 Global Mask Register A Extended ID2 (C1GMSKAE2)	<Address: H'0080 1424>
CAN1 Global Mask Register B Extended ID2 (C1GMSKBE2)	<Address: H'0080 142C>
CAN1 Local Mask Register A Extended ID2 (C1LMSKAE2)	<Address: H'0080 1434>
CAN1 Local Mask Register B Extended ID2 (C1LMSKBE2)	<Address: H'0080 143C>

b0	1	2	3	4	5	6	B7
0	0	EID12M	EID13M	EID14M	EID15M	EID16M	EID17M
		0	0	0	0	0	0

&lt;Upon exiting reset: H'00&gt;

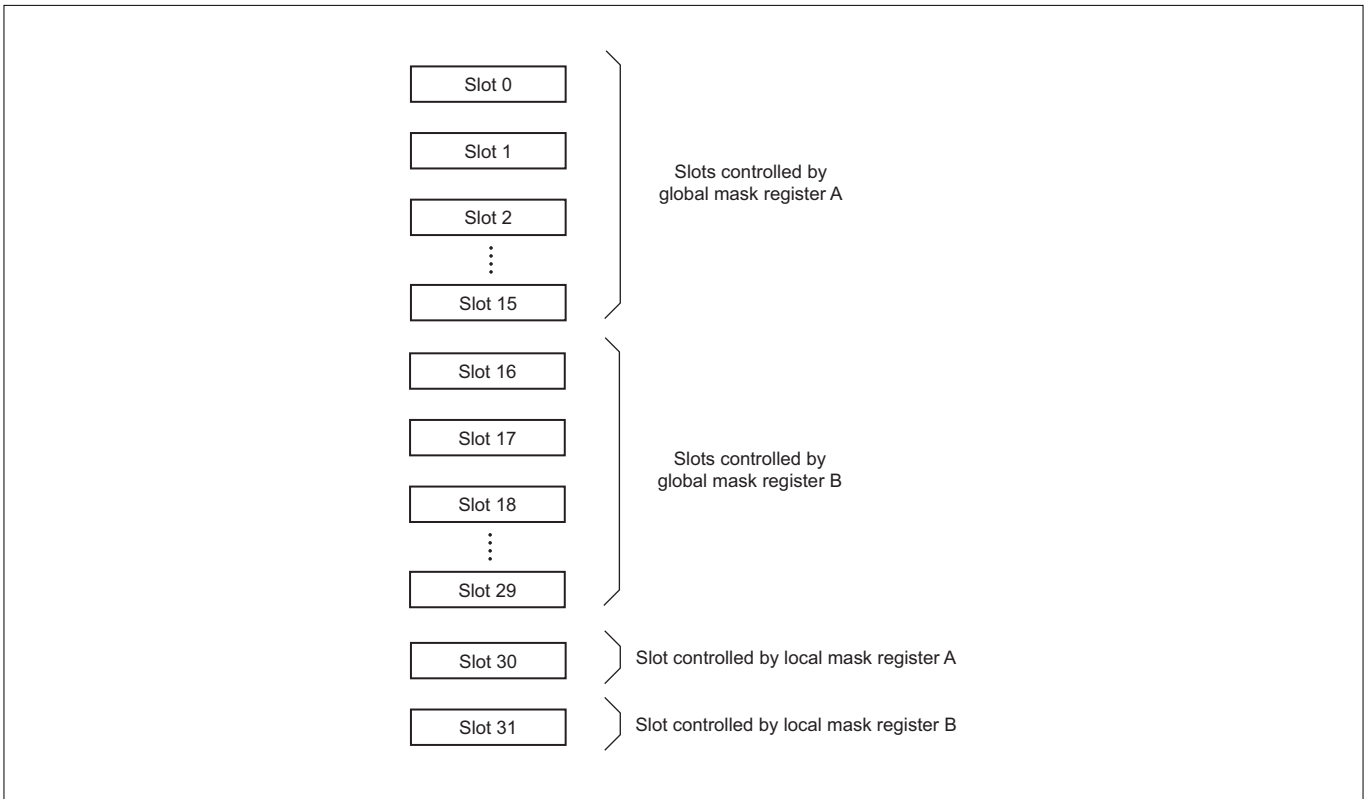
b	Bit Name	Function	R	W
0,1	No function assigned. Fix to "0."		0	0
2-7	EID12M-EID17M (Extended mask ID12-extended mask ID17)	0: ID not checked 1: ID checked	R	W

Four mask registers are used in acceptance filtering: global mask register A, global mask register B, local mask register A and local mask register B. The global mask registers A and B are used for message slots 0-15 and 16-29, while local mask registers A and B are used for message slots 30 and 31, respectively.

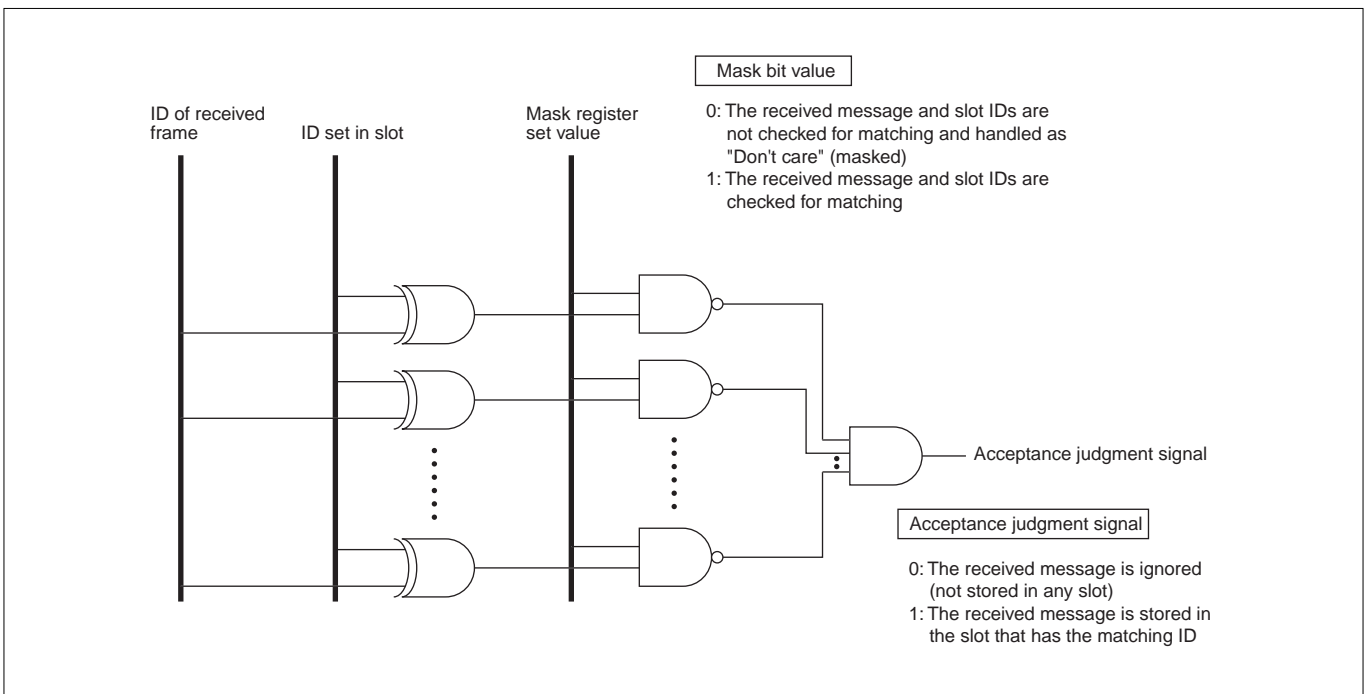
- If any bit in this register is set to "0," the corresponding ID bit is masked (assumed to have matched) during acceptance filtering.
- If any bit in this register is set to "1," the corresponding ID bit is compared with the receive ID during acceptance filtering and when it matches the ID set in the message slot, the received data is stored in it.

- Notes:
- EID0M corresponds to the MSB of the extended ID.
    - The global mask register A can only be modified when none of slots 0-15 have receive requests set.
    - The global mask register B can only be modified when none of slots 16-29 have receive requests set.
    - The local mask register A can only be modified when slot 30 does not have a receive request set.
    - The local mask register B can only be modified when slot 31 does not have a receive request set.





**Figure 13.2.26 Relationship between the Mask Registers and the Controlled Slots**



**Figure 13.2.27 Concept of Acceptance Filtering**

## 13.2.16 CAN Single-Shot Mode Control Registers

CAN0 Single-Shot Mode Control Register (CAN0SSMODEW)

&lt;Address: H'0080 1040&gt;

CAN1 Single-Shot Mode Control Register (CAN1SSMODEW)

&lt;Address: H'0080 1440&gt;

b0	1	2	3	4	5	6	7	8	9	10	11	12	13	14	b15
SSCNT0	SSCNT1	SSCNT2	SSCNT3	SSCNT4	SSCNT5	SSCNT6	SSCNT7	SSCNT8	SSCNT9	SSCNT10	SSCNT11	SSCNT12	SSCNT13	SSCNT14	SSCNT15
0	0	0	0	0	0	0	0	0	0	0	0	0	0	0	0

b16	17	18	19	20	21	22	23	24	25	26	27	28	29	30	b31
SSCNT16	SSCNT17	SSCNT18	SSCNT19	SSCNT20	SSCNT21	SSCNT22	SSCNT23	SSCNT24	SSCNT25	SSCNT26	SSCNT27	SSCNT28	SSCNT29	SSCNT30	SSCNT31
0	0	0	0	0	0	0	0	0	0	0	0	0	0	0	0

&lt;Upon exiting reset: H'0000 0000&gt;

b	Bit Name	Function	R	W
0	SSCNT0 (Slot 0 single-shot mode bit)	0: Normal mode	R	W
1	SSCNT1 (Slot 1 single-shot mode bit)	1: Single-shot mode		
2	SSCNT2 (Slot 2 single-shot mode bit)			
3	SSCNT3 (Slot 3 single-shot mode bit)			
4	SSCNT4 (Slot 4 single-shot mode bit)			
5	SSCNT5 (Slot 5 single-shot mode bit)			
6	SSCNT6 (Slot 6 single-shot mode bit)			
7	SSCNT7 (Slot 7 single-shot mode bit)			
8	SSCNT8 (Slot 8 single-shot mode bit)			
9	SSCNT9 (Slot 9 single-shot mode bit)			
10	SSCNT10 (Slot 10 single-shot mode bit)			
11	SSCNT11 (Slot 11 single-shot mode bit)			
12	SSCNT12 (Slot 12 single-shot mode bit)			
13	SSCNT13 (Slot 13 single-shot mode bit)			
14	SSCNT14 (Slot 14 single-shot mode bit)			
15	SSCNT15 (Slot 15 single-shot mode bit)			
16	SSCNT16 (Slot 16 single-shot mode bit)			
17	SSCNT17 (Slot 17 single-shot mode bit)			
18	SSCNT18 (Slot 18 single-shot mode bit)			
19	SSCNT19 (Slot 19 single-shot mode bit)			
20	SSCNT20 (Slot 20 single-shot mode bit)			
21	SSCNT21 (Slot 21 single-shot mode bit)			
22	SSCNT22 (Slot 22 single-shot mode bit)			
23	SSCNT23 (Slot 23 single-shot mode bit)			
24	SSCNT24 (Slot 24 single-shot mode bit)			
25	SSCNT25 (Slot 25 single-shot mode bit)			
26	SSCNT26 (Slot 26 single-shot mode bit)			
27	SSCNT27 (Slot 27 single-shot mode bit)			
28	SSCNT28 (Slot 28 single-shot mode bit)			
29	SSCNT29 (Slot 29 single-shot mode bit)			
30	SSCNT30 (Slot 30 single-shot mode bit)			
31	SSCNT31 (Slot 31 single-shot mode bit)			

Normally in CAN, if transmission has failed for reasons of arbitration-lost or transmit error, the transmit operation is continued until successfully transmitted. This register is used to specify for each slot whether or not to retry a transmit operation in such a case.

In single-shot mode, if transmission fails for reasons of arbitration-lost or transmit error, the transmit operation is not retried. If any SSCNTn bit (n = 0–31) is set to "1," the corresponding slot operates in single-shot mode.

Note: • Settings of this register can only be changed when the message slot control register for the slot whose corresponding bit is to be modified is in the H'00 state.

### 13.2.17 CAN Message Slot Control Registers

CAN0 Message Slot 0 Control Register (C0MSL0CNT)	<Address: H'0080 1050>
CAN0 Message Slot 1 Control Register (C0MSL1CNT)	<Address: H'0080 1051>
CAN0 Message Slot 2 Control Register (C0MSL2CNT)	<Address: H'0080 1052>
CAN0 Message Slot 3 Control Register (C0MSL3CNT)	<Address: H'0080 1053>
CAN0 Message Slot 4 Control Register (C0MSL4CNT)	<Address: H'0080 1054>
CAN0 Message Slot 5 Control Register (C0MSL5CNT)	<Address: H'0080 1055>
CAN0 Message Slot 6 Control Register (C0MSL6CNT)	<Address: H'0080 1056>
CAN0 Message Slot 7 Control Register (C0MSL7CNT)	<Address: H'0080 1057>
CAN0 Message Slot 8 Control Register (C0MSL8CNT)	<Address: H'0080 1058>
CAN0 Message Slot 9 Control Register (C0MSL9CNT)	<Address: H'0080 1059>
CAN0 Message Slot 10 Control Register (C0MSL10CNT)	<Address: H'0080 105A>
CAN0 Message Slot 11 Control Register (C0MSL11CNT)	<Address: H'0080 105B>
CAN0 Message Slot 12 Control Register (C0MSL12CNT)	<Address: H'0080 105C>
CAN0 Message Slot 13 Control Register (C0MSL13CNT)	<Address: H'0080 105D>
CAN0 Message Slot 14 Control Register (C0MSL14CNT)	<Address: H'0080 105E>
CAN0 Message Slot 15 Control Register (C0MSL15CNT)	<Address: H'0080 105F>
CAN0 Message Slot 16 Control Register (C0MSL16CNT)	<Address: H'0080 1060>
CAN0 Message Slot 17 Control Register (C0MSL17CNT)	<Address: H'0080 1061>
CAN0 Message Slot 18 Control Register (C0MSL18CNT)	<Address: H'0080 1062>
CAN0 Message Slot 19 Control Register (C0MSL19CNT)	<Address: H'0080 1063>
CAN0 Message Slot 20 Control Register (C0MSL20CNT)	<Address: H'0080 1064>
CAN0 Message Slot 21 Control Register (C0MSL21CNT)	<Address: H'0080 1065>
CAN0 Message Slot 22 Control Register (C0MSL22CNT)	<Address: H'0080 1066>
CAN0 Message Slot 23 Control Register (C0MSL23CNT)	<Address: H'0080 1067>
CAN0 Message Slot 24 Control Register (C0MSL24CNT)	<Address: H'0080 1068>
CAN0 Message Slot 25 Control Register (C0MSL25CNT)	<Address: H'0080 1069>
CAN0 Message Slot 26 Control Register (C0MSL26CNT)	<Address: H'0080 106A>
CAN0 Message Slot 27 Control Register (C0MSL27CNT)	<Address: H'0080 106B>
CAN0 Message Slot 28 Control Register (C0MSL28CNT)	<Address: H'0080 106C>
CAN0 Message Slot 29 Control Register (C0MSL29CNT)	<Address: H'0080 106D>
CAN0 Message Slot 30 Control Register (C0MSL30CNT)	<Address: H'0080 106E>
CAN0 Message Slot 31 Control Register (C0MSL31CNT)	<Address: H'0080 106F>
CAN1 Message Slot 0 Control Register (C1MSL0CNT)	<Address: H'0080 1450>
CAN1 Message Slot 1 Control Register (C1MSL1CNT)	<Address: H'0080 1451>
CAN1 Message Slot 2 Control Register (C1MSL2CNT)	<Address: H'0080 1452>
CAN1 Message Slot 3 Control Register (C1MSL3CNT)	<Address: H'0080 1453>
CAN1 Message Slot 4 Control Register (C1MSL4CNT)	<Address: H'0080 1454>
CAN1 Message Slot 5 Control Register (C1MSL5CNT)	<Address: H'0080 1455>
CAN1 Message Slot 6 Control Register (C1MSL6CNT)	<Address: H'0080 1456>
CAN1 Message Slot 7 Control Register (C1MSL7CNT)	<Address: H'0080 1457>
CAN1 Message Slot 8 Control Register (C1MSL8CNT)	<Address: H'0080 1458>
CAN1 Message Slot 9 Control Register (C1MSL9CNT)	<Address: H'0080 1459>
CAN1 Message Slot 10 Control Register (C1MSL10CNT)	<Address: H'0080 145A>
CAN1 Message Slot 11 Control Register (C1MSL11CNT)	<Address: H'0080 145B>
CAN1 Message Slot 12 Control Register (C1MSL12CNT)	<Address: H'0080 145C>
CAN1 Message Slot 13 Control Register (C1MSL13CNT)	<Address: H'0080 145D>
CAN1 Message Slot 14 Control Register (C1MSL14CNT)	<Address: H'0080 145E>
CAN1 Message Slot 15 Control Register (C1MSL15CNT)	<Address: H'0080 145F>

CAN1 Message Slot 16 Control Register (C1MSL16CNT)	<Address: H'0080 1460>
CAN1 Message Slot 17 Control Register (C1MSL17CNT)	<Address: H'0080 1461>
CAN1 Message Slot 18 Control Register (C1MSL18CNT)	<Address: H'0080 1462>
CAN1 Message Slot 19 Control Register (C1MSL19CNT)	<Address: H'0080 1463>
CAN1 Message Slot 20 Control Register (C1MSL20CNT)	<Address: H'0080 1464>
CAN1 Message Slot 21 Control Register (C1MSL21CNT)	<Address: H'0080 1465>
CAN1 Message Slot 22 Control Register (C1MSL22CNT)	<Address: H'0080 1466>
CAN1 Message Slot 23 Control Register (C1MSL23CNT)	<Address: H'0080 1467>
CAN1 Message Slot 24 Control Register (C1MSL24CNT)	<Address: H'0080 1468>
CAN1 Message Slot 25 Control Register (C1MSL25CNT)	<Address: H'0080 1469>
CAN1 Message Slot 26 Control Register (C1MSL26CNT)	<Address: H'0080 146A>
CAN1 Message Slot 27 Control Register (C1MSL27CNT)	<Address: H'0080 146B>
CAN1 Message Slot 28 Control Register (C1MSL28CNT)	<Address: H'0080 146C>
CAN1 Message Slot 29 Control Register (C1MSL29CNT)	<Address: H'0080 146D>
CAN1 Message Slot 30 Control Register (C1MSL30CNT)	<Address: H'0080 146E>
CAN1 Message Slot 31 Control Register (C1MSL31CNT)	<Address: H'0080 146F>

b0(b8)	1	2	3	4	5	6	b7(b15)
TR	RR	RM	RL	RA	ML	TRSTAT	TRFIN
0	0	0	0	0	0	0	0

&lt;Upon exiting reset: H'00&gt;

b	Bit Name	Function	R	W
0 (8)	TR Transmit request bit	0: Do not use the message slot as transmit slot 1: Use the message slot as transmit slot	R	W
1 (9)	RR Receive request bit	0: Do not use the message slot as receive slot 1: Use the message slot as receive slot	R	W
2 (10)	RM Remote bit	0: Transmit/receive data frame 1: Transmit/receive remote frame	R	W
3 (11)	RL Automatic response inhibit bit	0: Enable automatic response for remote frame 1: Disable automatic response for remote frame	R	W
4 (12)	RA Remote active bit	During BasicCAN mode 0: Receive data frame (status) 1: Receive remote frame (status) During normal mode 0: Data frame 1: Remote frame	R	–
5 (13)	ML Message lost bit	0: No message was lost 1: Message was lost	R(Note 1)	
6 (14)	TRSTAT Transmit/receive status bit	During a transmit slot 0: Transmission idle 1: Transmit request accepted During a receive slot 0: Reception idle 1: Storing received data	R	–
7 (15)	TRFIN Transmission/reception finished bit	During a transmit slot 0: Not transmitted yet 1: Finished transmitting During a receive slot 0: Not received yet 1: Finished receiving	R(Note 1)	

Note 1: Only writing "0" is effective. Writing "1" has no effect; the bit retains the status it had before the write.

- Notes:
- If a transmit request is written to this register while the CAN module is reset (CAN0CNT/CAN1CNT FRST or RST bit = "1"), it starts sending upon detecting 11 consecutive recessive bits on the CAN bus after exiting the reset state.
  - If data/remote frame transmit requests are issued for two or more slots, the slot with the smallest slot number sends a frame. If data/remote frame receive requests are issued for two or more slots, the slot with the smallest slot number among the slots satisfying the receive condition receives a frame.
  - If transmission failed when single-shot mode is selected, this register is cleared to H'00.

#### (1) TR (Transmit Request) bit (Bits 0, 8)

To use the message slot as a transmit slot, set this bit to "1." To use the message slot as a data frame or remote frame receive slot, set this bit to "0."

#### (2) RR (Receive Request) bit (Bits 1, 9)

To use the message slot as a receive slot, set this bit to "1." To use the message slot as a data frame or remote frame transmit slot, set this bit to "0."

If TR (Transmit Request) bit and RR (Receive Request) bit both are set to "1," device operation is undefined.

#### (3) RM (Remote) bit (Bits 2, 10)

To handle remote frames in the message slot, set this bit to "1." There are following two methods of settings to handle remote frames:

- **Set for remote frame transmission**

The data set in the message slot is transmitted as a remote frame. When the CAN module finished sending, the slot automatically changes to a data frame receive slot. However, if a data frame is received before the CAN module finished sending a remote frame, the received data is stored in the message slot and the remote frame is not transmitted.

- **Set for remote frame reception**

Remote frames are received. The processing to be performed after receiving a remote frame is selected by RL (automatic response inhibit) bit.

#### (4) RL (Automatic Response Inhibit) bit (Bits 3, 11)

This bit is effective when the message slot has been set as a remote frame receive slot. It selects the processing to be performed after receiving a remote frame. If this bit is set to "0," the message slot automatically changes to a transmit slot after receiving a remote frame and transmits the data set in it as a data frame. If this bit is set to "1," the message slot stops operating after receiving a remote frame.

Note: • Always set this bit to "0" unless the message slot is set for remote frame reception.

#### (5) RA (Remote Active) bit (Bits 4, 12)

This bit functions differently for slots 0-29 and slots 30 and 31.

- **Slots 0–29**

This bit is set to "1" when the message slot is set for remote frame transmission (reception). Then, when remote frame transmission (reception) is completed, the bit is cleared to "0."

- **Slots 30 and 31**

The function of this bit differs depending on how the CAN Control Register BCM (BasicCAN Mode) bit is set.

If BCM = "0" (normal operation), this bit is set to "1" when the message slot is set for remote frame transmission (reception).

If BCM = "1" (BasicCAN), this bit indicates which type of frame is received. During BasicCAN mode, the received data is stored in slots 30 and 31 for both data and remote frames.

If RA = "0," it means that the frame stored in the slot is a data frame.

If RA = "1," it means that the frame stored in the slot is a remote frame.

**(6) ML (Message Lost) bit (Bits 5, 13)**

This bit is effective for receive slots. It is set to "1" when unread received data contained in the message slot is overwritten by reception. This bit is cleared by writing "0" in software.

**(7) TRSTAT (Transmit/Receive Status) bit (Bits 6, 14)**

This bit indicates that the CAN module is sending or receiving and is accessing the message slot. This bit is set to "1" when the CAN module is accessing, and set to "0" when not accessing.

- **During a transmit slot**

This bit is set to "1" when a transmit request for the message slot is accepted. It is cleared to "0" when the CAN module lost in bus arbitration, when a CAN bus error occurs, or when transmission is completed.

- **During a receive slot**

This bit is set to "1" while the CAN module is receiving data, with the received data being stored in the message slot. Note that the value read from the message slot while the TRSTAT bit remains set is undefined.

**(8) TRFIN (Transmit/Receive Finished) bit (Bits 7, 15)**

This bit indicates that the CAN module finished sending or receiving.

- **When set for a transmit slot**

This bit is set to "1" when the CAN module finished sending the data stored in the message slot.

This bit is cleared by writing "0" in software. However, it cannot be cleared when the TRSTAT (Transmit/Receive Status) bit = "1."

- **When set for a receive slot**

This bit is set to "1" when the CAN module finished receiving normally the data to be stored in the message slot. This bit is cleared by writing "0" in software. However, it cannot be cleared when the TRSTAT (Transmit/Receive Status) bit = "1."

Notes: • Before reading the received data out of the message slot, be sure to clear the TRFIN (Transmit/Receive Finished) bit to "0." If the TRFIN (Transmit/Receive Finished) bit happens to be set to "1" after a read, it means that new received data was stored while reading and the read data contains an undefined value. In that case, discard the read data, clear the TRFIN bit to "0" and read out data again.

- When sending/receiving remote frames, the TRFIN bit is automatically cleared to "0" by hardware. Therefore, the TRFIN bit cannot be used as a transmission/reception-finished flag.

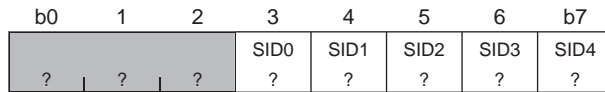


## 13.2.18 CAN Message Slots

CAN0 Message Slot 0 Standard ID0 (C0MSL0SID0)	<Address: H'0080 1100>
CAN0 Message Slot 1 Standard ID0 (C0MSL1SID0)	<Address: H'0080 1110>
CAN0 Message Slot 2 Standard ID0 (C0MSL2SID0)	<Address: H'0080 1120>
CAN0 Message Slot 3 Standard ID0 (C0MSL3SID0)	<Address: H'0080 1130>
CAN0 Message Slot 4 Standard ID0 (C0MSL4SID0)	<Address: H'0080 1140>
CAN0 Message Slot 5 Standard ID0 (C0MSL5SID0)	<Address: H'0080 1150>
CAN0 Message Slot 6 Standard ID0 (C0MSL6SID0)	<Address: H'0080 1160>
CAN0 Message Slot 7 Standard ID0 (C0MSL7SID0)	<Address: H'0080 1170>
CAN0 Message Slot 8 Standard ID0 (C0MSL8SID0)	<Address: H'0080 1180>
CAN0 Message Slot 9 Standard ID0 (C0MSL9SID0)	<Address: H'0080 1190>
CAN0 Message Slot 10 Standard ID0 (C0MSL10SID0)	<Address: H'0080 11A0>
CAN0 Message Slot 11 Standard ID0 (C0MSL11SID0)	<Address: H'0080 11B0>
CAN0 Message Slot 12 Standard ID0 (C0MSL12SID0)	<Address: H'0080 11C0>
CAN0 Message Slot 13 Standard ID0 (C0MSL13SID0)	<Address: H'0080 11D0>
CAN0 Message Slot 14 Standard ID0 (C0MSL14SID0)	<Address: H'0080 11E0>
CAN0 Message Slot 15 Standard ID0 (C0MSL15SID0)	<Address: H'0080 11F0>
CAN0 Message Slot 16 Standard ID0 (C0MSL16SID0)	<Address: H'0080 1200>
CAN0 Message Slot 17 Standard ID0 (C0MSL17SID0)	<Address: H'0080 1210>
CAN0 Message Slot 18 Standard ID0 (C0MSL18SID0)	<Address: H'0080 1220>
CAN0 Message Slot 19 Standard ID0 (C0MSL19SID0)	<Address: H'0080 1230>
CAN0 Message Slot 20 Standard ID0 (C0MSL20SID0)	<Address: H'0080 1240>
CAN0 Message Slot 21 Standard ID0 (C0MSL21SID0)	<Address: H'0080 1250>
CAN0 Message Slot 22 Standard ID0 (C0MSL22SID0)	<Address: H'0080 1260>
CAN0 Message Slot 23 Standard ID0 (C0MSL23SID0)	<Address: H'0080 1270>
CAN0 Message Slot 24 Standard ID0 (C0MSL24SID0)	<Address: H'0080 1280>
CAN0 Message Slot 25 Standard ID0 (C0MSL25SID0)	<Address: H'0080 1290>
CAN0 Message Slot 26 Standard ID0 (C0MSL26SID0)	<Address: H'0080 12A0>
CAN0 Message Slot 27 Standard ID0 (C0MSL27SID0)	<Address: H'0080 12B0>
CAN0 Message Slot 28 Standard ID0 (C0MSL28SID0)	<Address: H'0080 12C0>
CAN0 Message Slot 29 Standard ID0 (C0MSL29SID0)	<Address: H'0080 12D0>
CAN0 Message Slot 30 Standard ID0 (C0MSL30SID0)	<Address: H'0080 12E0>
CAN0 Message Slot 31 Standard ID0 (C0MSL31SID0)	<Address: H'0080 12F0>
CAN1 Message Slot 0 Standard ID0 (C1MSL0SID0)	<Address: H'0080 1500>
CAN1 Message Slot 1 Standard ID0 (C1MSL1SID0)	<Address: H'0080 1510>
CAN1 Message Slot 2 Standard ID0 (C1MSL2SID0)	<Address: H'0080 1520>
CAN1 Message Slot 3 Standard ID0 (C1MSL3SID0)	<Address: H'0080 1530>
CAN1 Message Slot 4 Standard ID0 (C1MSL4SID0)	<Address: H'0080 1540>
CAN1 Message Slot 5 Standard ID0 (C1MSL5SID0)	<Address: H'0080 1550>
CAN1 Message Slot 6 Standard ID0 (C1MSL6SID0)	<Address: H'0080 1560>
CAN1 Message Slot 7 Standard ID0 (C1MSL7SID0)	<Address: H'0080 1570>
CAN1 Message Slot 8 Standard ID0 (C1MSL8SID0)	<Address: H'0080 1580>
CAN1 Message Slot 9 Standard ID0 (C1MSL9SID0)	<Address: H'0080 1590>
CAN1 Message Slot 10 Standard ID0 (C1MSL10SID0)	<Address: H'0080 15A0>
CAN1 Message Slot 11 Standard ID0 (C1MSL11SID0)	<Address: H'0080 15B0>
CAN1 Message Slot 12 Standard ID0 (C1MSL12SID0)	<Address: H'0080 15C0>
CAN1 Message Slot 13 Standard ID0 (C1MSL13SID0)	<Address: H'0080 15D0>
CAN1 Message Slot 14 Standard ID0 (C1MSL14SID0)	<Address: H'0080 15E0>
CAN1 Message Slot 15 Standard ID0 (C1MSL15SID0)	<Address: H'0080 15F0>



CAN1 Message Slot 16 Standard ID0 (C1MSL16SID0)	<Address: H'0080 1600>
CAN1 Message Slot 17 Standard ID0 (C1MSL17SID0)	<Address: H'0080 1610>
CAN1 Message Slot 18 Standard ID0 (C1MSL18SID0)	<Address: H'0080 1620>
CAN1 Message Slot 19 Standard ID0 (C1MSL19SID0)	<Address: H'0080 1630>
CAN1 Message Slot 20 Standard ID0 (C1MSL20SID0)	<Address: H'0080 1640>
CAN1 Message Slot 21 Standard ID0 (C1MSL21SID0)	<Address: H'0080 1650>
CAN1 Message Slot 22 Standard ID0 (C1MSL22SID0)	<Address: H'0080 1660>
CAN1 Message Slot 23 Standard ID0 (C1MSL23SID0)	<Address: H'0080 1670>
CAN1 Message Slot 24 Standard ID0 (C1MSL24SID0)	<Address: H'0080 1680>
CAN1 Message Slot 25 Standard ID0 (C1MSL25SID0)	<Address: H'0080 1690>
CAN1 Message Slot 26 Standard ID0 (C1MSL26SID0)	<Address: H'0080 16A0>
CAN1 Message Slot 27 Standard ID0 (C1MSL27SID0)	<Address: H'0080 16B0>
CAN1 Message Slot 28 Standard ID0 (C1MSL28SID0)	<Address: H'0080 16C0>
CAN1 Message Slot 29 Standard ID0 (C1MSL29SID0)	<Address: H'0080 16D0>
CAN1 Message Slot 30 Standard ID0 (C1MSL30SID0)	<Address: H'0080 16E0>
CAN1 Message Slot 31 Standard ID0 (C1MSL31SID0)	<Address: H'0080 16F0>



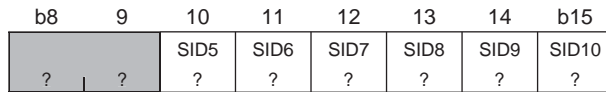
&lt;Upon exiting reset: Undefined&gt;

b	Bit Name	Function	R	W
0–2	No function assigned. Fix to "0."		0	0
3–7	SID0–SID4 (Standard ID0–standard ID4)	Standard ID0–standard ID4	R	W

These registers are the memory space for transmit and receive frames.

CAN0 Message Slot 0 Standard ID1 (C0MSL0SID1)	<Address: H'0080 1101>
CAN0 Message Slot 1 Standard ID1 (C0MSL1SID1)	<Address: H'0080 1111>
CAN0 Message Slot 2 Standard ID1 (C0MSL2SID1)	<Address: H'0080 1121>
CAN0 Message Slot 3 Standard ID1 (C0MSL3SID1)	<Address: H'0080 1131>
CAN0 Message Slot 4 Standard ID1 (C0MSL4SID1)	<Address: H'0080 1141>
CAN0 Message Slot 5 Standard ID1 (C0MSL5SID1)	<Address: H'0080 1151>
CAN0 Message Slot 6 Standard ID1 (C0MSL6SID1)	<Address: H'0080 1161>
CAN0 Message Slot 7 Standard ID1 (C0MSL7SID1)	<Address: H'0080 1171>
CAN0 Message Slot 8 Standard ID1 (C0MSL8SID1)	<Address: H'0080 1181>
CAN0 Message Slot 9 Standard ID1 (C0MSL9SID1)	<Address: H'0080 1191>
CAN0 Message Slot 10 Standard ID1 (C0MSL10SID1)	<Address: H'0080 11A1>
CAN0 Message Slot 11 Standard ID1 (C0MSL11SID1)	<Address: H'0080 11B1>
CAN0 Message Slot 12 Standard ID1 (C0MSL12SID1)	<Address: H'0080 11C1>
CAN0 Message Slot 13 Standard ID1 (C0MSL13SID1)	<Address: H'0080 11D1>
CAN0 Message Slot 14 Standard ID1 (C0MSL14SID1)	<Address: H'0080 11E1>
CAN0 Message Slot 15 Standard ID1 (C0MSL15SID1)	<Address: H'0080 11F1>
CAN0 Message Slot 16 Standard ID1 (C0MSL16SID1)	<Address: H'0080 1201>
CAN0 Message Slot 17 Standard ID1 (C0MSL17SID1)	<Address: H'0080 1211>
CAN0 Message Slot 18 Standard ID1 (C0MSL18SID1)	<Address: H'0080 1221>
CAN0 Message Slot 19 Standard ID1 (C0MSL19SID1)	<Address: H'0080 1231>
CAN0 Message Slot 20 Standard ID1 (C0MSL20SID1)	<Address: H'0080 1241>
CAN0 Message Slot 21 Standard ID1 (C0MSL21SID1)	<Address: H'0080 1251>
CAN0 Message Slot 22 Standard ID1 (C0MSL22SID1)	<Address: H'0080 1261>
CAN0 Message Slot 23 Standard ID1 (C0MSL23SID1)	<Address: H'0080 1271>
CAN0 Message Slot 24 Standard ID1 (C0MSL24SID1)	<Address: H'0080 1281>
CAN0 Message Slot 25 Standard ID1 (C0MSL25SID1)	<Address: H'0080 1291>
CAN0 Message Slot 26 Standard ID1 (C0MSL26SID1)	<Address: H'0080 12A1>
CAN0 Message Slot 27 Standard ID1 (C0MSL27SID1)	<Address: H'0080 12B1>
CAN0 Message Slot 28 Standard ID1 (C0MSL28SID1)	<Address: H'0080 12C1>
CAN0 Message Slot 29 Standard ID1 (C0MSL29SID1)	<Address: H'0080 12D1>
CAN0 Message Slot 30 Standard ID1 (C0MSL30SID1)	<Address: H'0080 12E1>
CAN0 Message Slot 31 Standard ID1 (C0MSL31SID1)	<Address: H'0080 12F1>
CAN1 Message Slot 0 Standard ID1 (C1MSL0SID1)	<Address: H'0080 1501>
CAN1 Message Slot 1 Standard ID1 (C1MSL1SID1)	<Address: H'0080 1511>
CAN1 Message Slot 2 Standard ID1 (C1MSL2SID1)	<Address: H'0080 1521>
CAN1 Message Slot 3 Standard ID1 (C1MSL3SID1)	<Address: H'0080 1531>
CAN1 Message Slot 4 Standard ID1 (C1MSL4SID1)	<Address: H'0080 1541>
CAN1 Message Slot 5 Standard ID1 (C1MSL5SID1)	<Address: H'0080 1551>
CAN1 Message Slot 6 Standard ID1 (C1MSL6SID1)	<Address: H'0080 1561>
CAN1 Message Slot 7 Standard ID1 (C1MSL7SID1)	<Address: H'0080 1571>
CAN1 Message Slot 8 Standard ID1 (C1MSL8SID1)	<Address: H'0080 1581>
CAN1 Message Slot 9 Standard ID1 (C1MSL9SID1)	<Address: H'0080 1591>
CAN1 Message Slot 10 Standard ID1 (C1MSL10SID1)	<Address: H'0080 15A1>
CAN1 Message Slot 11 Standard ID1 (C1MSL11SID1)	<Address: H'0080 15B1>
CAN1 Message Slot 12 Standard ID1 (C1MSL12SID1)	<Address: H'0080 15C1>
CAN1 Message Slot 13 Standard ID1 (C1MSL13SID1)	<Address: H'0080 15D1>
CAN1 Message Slot 14 Standard ID1 (C1MSL14SID1)	<Address: H'0080 15E1>
CAN1 Message Slot 15 Standard ID1 (C1MSL15SID1)	<Address: H'0080 15F1>

CAN1 Message Slot 16 Standard ID1 (C1MSL16SID1)	<Address: H'0080 1601>
CAN1 Message Slot 17 Standard ID1 (C1MSL17SID1)	<Address: H'0080 1611>
CAN1 Message Slot 18 Standard ID1 (C1MSL18SID1)	<Address: H'0080 1621>
CAN1 Message Slot 19 Standard ID1 (C1MSL19SID1)	<Address: H'0080 1631>
CAN1 Message Slot 20 Standard ID1 (C1MSL20SID1)	<Address: H'0080 1641>
CAN1 Message Slot 21 Standard ID1 (C1MSL21SID1)	<Address: H'0080 1651>
CAN1 Message Slot 22 Standard ID1 (C1MSL22SID1)	<Address: H'0080 1661>
CAN1 Message Slot 23 Standard ID1 (C1MSL23SID1)	<Address: H'0080 1671>
CAN1 Message Slot 24 Standard ID1 (C1MSL24SID1)	<Address: H'0080 1681>
CAN1 Message Slot 25 Standard ID1 (C1MSL25SID1)	<Address: H'0080 1691>
CAN1 Message Slot 26 Standard ID1 (C1MSL26SID1)	<Address: H'0080 16A1>
CAN1 Message Slot 27 Standard ID1 (C1MSL27SID1)	<Address: H'0080 16B1>
CAN1 Message Slot 28 Standard ID1 (C1MSL28SID1)	<Address: H'0080 16C1>
CAN1 Message Slot 29 Standard ID1 (C1MSL29SID1)	<Address: H'0080 16D1>
CAN1 Message Slot 30 Standard ID1 (C1MSL30SID1)	<Address: H'0080 16E1>
CAN1 Message Slot 31 Standard ID1 (C1MSL31SID1)	<Address: H'0080 16F1>



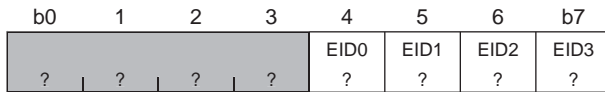
<Upon exiting reset: Undefined>

b	Bit Name	Function	R	W
8, 9	No function assigned. Fix to "0."		0	0
10–15	SID5–SID10 (Standard ID5–standard ID10)	Standard ID5–standard ID10	R	W

These registers are the memory space for transmit and receive frames.

CAN0 Message Slot 0 Extended ID0 (C0MSL0EID0)	<Address: H'0080 1102>
CAN0 Message Slot 1 Extended ID0 (C0MSL1EID0)	<Address: H'0080 1112>
CAN0 Message Slot 2 Extended ID0 (C0MSL2EID0)	<Address: H'0080 1122>
CAN0 Message Slot 3 Extended ID0 (C0MSL3EID0)	<Address: H'0080 1132>
CAN0 Message Slot 4 Extended ID0 (C0MSL4EID0)	<Address: H'0080 1142>
CAN0 Message Slot 5 Extended ID0 (C0MSL5EID0)	<Address: H'0080 1152>
CAN0 Message Slot 6 Extended ID0 (C0MSL6EID0)	<Address: H'0080 1162>
CAN0 Message Slot 7 Extended ID0 (C0MSL7EID0)	<Address: H'0080 1172>
CAN0 Message Slot 8 Extended ID0 (C0MSL8EID0)	<Address: H'0080 1182>
CAN0 Message Slot 9 Extended ID0 (C0MSL9EID0)	<Address: H'0080 1192>
CAN0 Message Slot 10 Extended ID0 (C0MSL10EID0)	<Address: H'0080 11A2>
CAN0 Message Slot 11 Extended ID0 (C0MSL11EID0)	<Address: H'0080 11B2>
CAN0 Message Slot 12 Extended ID0 (C0MSL12EID0)	<Address: H'0080 11C2>
CAN0 Message Slot 13 Extended ID0 (C0MSL13EID0)	<Address: H'0080 11D2>
CAN0 Message Slot 14 Extended ID0 (C0MSL14EID0)	<Address: H'0080 11E2>
CAN0 Message Slot 15 Extended ID0 (C0MSL15EID0)	<Address: H'0080 11F2>
CAN0 Message Slot 16 Extended ID0 (C0MSL16EID0)	<Address: H'0080 1202>
CAN0 Message Slot 17 Extended ID0 (C0MSL17EID0)	<Address: H'0080 1212>
CAN0 Message Slot 18 Extended ID0 (C0MSL18EID0)	<Address: H'0080 1222>
CAN0 Message Slot 19 Extended ID0 (C0MSL19EID0)	<Address: H'0080 1232>
CAN0 Message Slot 20 Extended ID0 (C0MSL20EID0)	<Address: H'0080 1242>
CAN0 Message Slot 21 Extended ID0 (C0MSL21EID0)	<Address: H'0080 1252>
CAN0 Message Slot 22 Extended ID0 (C0MSL22EID0)	<Address: H'0080 1262>
CAN0 Message Slot 23 Extended ID0 (C0MSL23EID0)	<Address: H'0080 1272>
CAN0 Message Slot 24 Extended ID0 (C0MSL24EID0)	<Address: H'0080 1282>
CAN0 Message Slot 25 Extended ID0 (C0MSL25EID0)	<Address: H'0080 1292>
CAN0 Message Slot 26 Extended ID0 (C0MSL26EID0)	<Address: H'0080 12A2>
CAN0 Message Slot 27 Extended ID0 (C0MSL27EID0)	<Address: H'0080 12B2>
CAN0 Message Slot 28 Extended ID0 (C0MSL28EID0)	<Address: H'0080 12C2>
CAN0 Message Slot 29 Extended ID0 (C0MSL29EID0)	<Address: H'0080 12D2>
CAN0 Message Slot 30 Extended ID0 (C0MSL30EID0)	<Address: H'0080 12E2>
CAN0 Message Slot 31 Extended ID0 (C0MSL31EID0)	<Address: H'0080 12F2>
CAN1 Message Slot 0 Extended ID0 (C1MSL0EID0)	<Address: H'0080 1502>
CAN1 Message Slot 1 Extended ID0 (C1MSL1EID0)	<Address: H'0080 1512>
CAN1 Message Slot 2 Extended ID0 (C1MSL2EID0)	<Address: H'0080 1522>
CAN1 Message Slot 3 Extended ID0 (C1MSL3EID0)	<Address: H'0080 1532>
CAN1 Message Slot 4 Extended ID0 (C1MSL4EID0)	<Address: H'0080 1542>
CAN1 Message Slot 5 Extended ID0 (C1MSL5EID0)	<Address: H'0080 1552>
CAN1 Message Slot 6 Extended ID0 (C1MSL6EID0)	<Address: H'0080 1562>
CAN1 Message Slot 7 Extended ID0 (C1MSL7EID0)	<Address: H'0080 1572>
CAN1 Message Slot 8 Extended ID0 (C1MSL8EID0)	<Address: H'0080 1582>
CAN1 Message Slot 9 Extended ID0 (C1MSL9EID0)	<Address: H'0080 1592>
CAN1 Message Slot 10 Extended ID0 (C1MSL10EID0)	<Address: H'0080 15A2>
CAN1 Message Slot 11 Extended ID0 (C1MSL11EID0)	<Address: H'0080 15B2>
CAN1 Message Slot 12 Extended ID0 (C1MSL12EID0)	<Address: H'0080 15C2>
CAN1 Message Slot 13 Extended ID0 (C1MSL13EID0)	<Address: H'0080 15D2>
CAN1 Message Slot 14 Extended ID0 (C1MSL14EID0)	<Address: H'0080 15E2>
CAN1 Message Slot 15 Extended ID0 (C1MSL15EID0)	<Address: H'0080 15F2>

CAN1 Message Slot 16 Extended ID0 (C1MSL16EID0)	<Address: H'0080 1602>
CAN1 Message Slot 17 Extended ID0 (C1MSL17EID0)	<Address: H'0080 1612>
CAN1 Message Slot 18 Extended ID0 (C1MSL18EID0)	<Address: H'0080 1622>
CAN1 Message Slot 19 Extended ID0 (C1MSL19EID0)	<Address: H'0080 1632>
CAN1 Message Slot 20 Extended ID0 (C1MSL20EID0)	<Address: H'0080 1642>
CAN1 Message Slot 21 Extended ID0 (C1MSL21EID0)	<Address: H'0080 1652>
CAN1 Message Slot 22 Extended ID0 (C1MSL22EID0)	<Address: H'0080 1662>
CAN1 Message Slot 23 Extended ID0 (C1MSL23EID0)	<Address: H'0080 1672>
CAN1 Message Slot 24 Extended ID0 (C1MSL24EID0)	<Address: H'0080 1682>
CAN1 Message Slot 25 Extended ID0 (C1MSL25EID0)	<Address: H'0080 1692>
CAN1 Message Slot 26 Extended ID0 (C1MSL26EID0)	<Address: H'0080 16A2>
CAN1 Message Slot 27 Extended ID0 (C1MSL27EID0)	<Address: H'0080 16B2>
CAN1 Message Slot 28 Extended ID0 (C1MSL28EID0)	<Address: H'0080 16C2>
CAN1 Message Slot 29 Extended ID0 (C1MSL29EID0)	<Address: H'0080 16D2>
CAN1 Message Slot 30 Extended ID0 (C1MSL30EID0)	<Address: H'0080 16E2>
CAN1 Message Slot 31 Extended ID0 (C1MSL31EID0)	<Address: H'0080 16F2>



<Upon exiting reset: Undefined>

b	Bit Name	Function	R	W
0–3	No function assigned. Fix to "0."		0	0
4–7	EID0–EID3 (Extended ID0–extended ID3)	Extended ID0–extended ID3	R	W

These registers are the memory space for transmit and receive frames.

Note: • If the message slot is set for the receive slot standard ID format, an undefined value is written to the EID bits when storing received data.

CAN0 Message Slot 0 Extended ID1 (C0MSL0EID1)	<Address: H'0080 1103>
CAN0 Message Slot 1 Extended ID1 (C0MSL1EID1)	<Address: H'0080 1113>
CAN0 Message Slot 2 Extended ID1 (C0MSL2EID1)	<Address: H'0080 1123>
CAN0 Message Slot 3 Extended ID1 (C0MSL3EID1)	<Address: H'0080 1133>
CAN0 Message Slot 4 Extended ID1 (C0MSL4EID1)	<Address: H'0080 1143>
CAN0 Message Slot 5 Extended ID1 (C0MSL5EID1)	<Address: H'0080 1153>
CAN0 Message Slot 6 Extended ID1 (C0MSL6EID1)	<Address: H'0080 1163>
CAN0 Message Slot 7 Extended ID1 (C0MSL7EID1)	<Address: H'0080 1173>
CAN0 Message Slot 8 Extended ID1 (C0MSL8EID1)	<Address: H'0080 1183>
CAN0 Message Slot 9 Extended ID1 (C0MSL9EID1)	<Address: H'0080 1193>
CAN0 Message Slot 10 Extended ID1 (C0MSL10EID1)	<Address: H'0080 11A3>
CAN0 Message Slot 11 Extended ID1 (C0MSL11EID1)	<Address: H'0080 11B3>
CAN0 Message Slot 12 Extended ID1 (C0MSL12EID1)	<Address: H'0080 11C3>
CAN0 Message Slot 13 Extended ID1 (C0MSL13EID1)	<Address: H'0080 11D3>
CAN0 Message Slot 14 Extended ID1 (C0MSL14EID1)	<Address: H'0080 11E3>
CAN0 Message Slot 15 Extended ID1 (C0MSL15EID1)	<Address: H'0080 11F3>
CAN0 Message Slot 16 Extended ID1 (C0MSL16EID1)	<Address: H'0080 1203>
CAN0 Message Slot 17 Extended ID1 (C0MSL17EID1)	<Address: H'0080 1213>
CAN0 Message Slot 18 Extended ID1 (C0MSL18EID1)	<Address: H'0080 1223>
CAN0 Message Slot 19 Extended ID1 (C0MSL19EID1)	<Address: H'0080 1233>
CAN0 Message Slot 20 Extended ID1 (C0MSL20EID1)	<Address: H'0080 1243>
CAN0 Message Slot 21 Extended ID1 (C0MSL21EID1)	<Address: H'0080 1253>
CAN0 Message Slot 22 Extended ID1 (C0MSL22EID1)	<Address: H'0080 1263>
CAN0 Message Slot 23 Extended ID1 (C0MSL23EID1)	<Address: H'0080 1273>
CAN0 Message Slot 24 Extended ID1 (C0MSL24EID1)	<Address: H'0080 1283>
CAN0 Message Slot 25 Extended ID1 (C0MSL25EID1)	<Address: H'0080 1293>
CAN0 Message Slot 26 Extended ID1 (C0MSL26EID1)	<Address: H'0080 12A3>
CAN0 Message Slot 27 Extended ID1 (C0MSL27EID1)	<Address: H'0080 12B3>
CAN0 Message Slot 28 Extended ID1 (C0MSL28EID1)	<Address: H'0080 12C3>
CAN0 Message Slot 29 Extended ID1 (C0MSL29EID1)	<Address: H'0080 12D3>
CAN0 Message Slot 30 Extended ID1 (C0MSL30EID1)	<Address: H'0080 12E3>
CAN0 Message Slot 31 Extended ID1 (C0MSL31EID1)	<Address: H'0080 12F3>
CAN1 Message Slot 0 Extended ID1 (C1MSL0EID1)	<Address: H'0080 1503>
CAN1 Message Slot 1 Extended ID1 (C1MSL1EID1)	<Address: H'0080 1513>
CAN1 Message Slot 2 Extended ID1 (C1MSL2EID1)	<Address: H'0080 1523>
CAN1 Message Slot 3 Extended ID1 (C1MSL3EID1)	<Address: H'0080 1533>
CAN1 Message Slot 4 Extended ID1 (C1MSL4EID1)	<Address: H'0080 1543>
CAN1 Message Slot 5 Extended ID1 (C1MSL5EID1)	<Address: H'0080 1553>
CAN1 Message Slot 6 Extended ID1 (C1MSL6EID1)	<Address: H'0080 1563>
CAN1 Message Slot 7 Extended ID1 (C1MSL7EID1)	<Address: H'0080 1573>
CAN1 Message Slot 8 Extended ID1 (C1MSL8EID1)	<Address: H'0080 1583>
CAN1 Message Slot 9 Extended ID1 (C1MSL9EID1)	<Address: H'0080 1593>
CAN1 Message Slot 10 Extended ID1 (C1MSL10EID1)	<Address: H'0080 15A3>
CAN1 Message Slot 11 Extended ID1 (C1MSL11EID1)	<Address: H'0080 15B3>
CAN1 Message Slot 12 Extended ID1 (C1MSL12EID1)	<Address: H'0080 15C3>
CAN1 Message Slot 13 Extended ID1 (C1MSL13EID1)	<Address: H'0080 15D3>
CAN1 Message Slot 14 Extended ID1 (C1MSL14EID1)	<Address: H'0080 15E3>
CAN1 Message Slot 15 Extended ID1 (C1MSL15EID1)	<Address: H'0080 15F3>

CAN1 Message Slot 16 Extended ID1 (C1MSL16EID1)	<Address: H'0080 1603>
CAN1 Message Slot 17 Extended ID1 (C1MSL17EID1)	<Address: H'0080 1613>
CAN1 Message Slot 18 Extended ID1 (C1MSL18EID1)	<Address: H'0080 1623>
CAN1 Message Slot 19 Extended ID1 (C1MSL19EID1)	<Address: H'0080 1633>
CAN1 Message Slot 20 Extended ID1 (C1MSL20EID1)	<Address: H'0080 1643>
CAN1 Message Slot 21 Extended ID1 (C1MSL21EID1)	<Address: H'0080 1653>
CAN1 Message Slot 22 Extended ID1 (C1MSL22EID1)	<Address: H'0080 1663>
CAN1 Message Slot 23 Extended ID1 (C1MSL23EID1)	<Address: H'0080 1673>
CAN1 Message Slot 24 Extended ID1 (C1MSL24EID1)	<Address: H'0080 1683>
CAN1 Message Slot 25 Extended ID1 (C1MSL25EID1)	<Address: H'0080 1693>
CAN1 Message Slot 26 Extended ID1 (C1MSL26EID1)	<Address: H'0080 16A3>
CAN1 Message Slot 27 Extended ID1 (C1MSL27EID1)	<Address: H'0080 16B3>
CAN1 Message Slot 28 Extended ID1 (C1MSL28EID1)	<Address: H'0080 16C3>
CAN1 Message Slot 29 Extended ID1 (C1MSL29EID1)	<Address: H'0080 16D3>
CAN1 Message Slot 30 Extended ID1 (C1MSL30EID1)	<Address: H'0080 16E3>
CAN1 Message Slot 31 Extended ID1 (C1MSL31EID1)	<Address: H'0080 16F3>

b8	9	10	11	12	13	14	b15
EID4	EID5	EID6	EID7	EID8	EID9	EID10	EID11
?	?	?	?	?	?	?	?

<Upon exiting reset: Undefined>

b	Bit Name	Function	R	W
8–15	EID4–EID11 (Extended ID4–extended ID11)	Extended ID4–extended ID11	R	W

These registers are the memory space for transmit and receive frames.

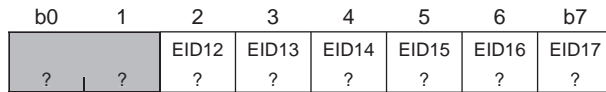
**Note:** • If the message slot is set for the receive slot standard ID format, an undefined value is written to the EID bits when storing received data.



CAN0 Message Slot 0 Extended ID2 (C0MSL0EID2)	<Address: H'0080 1104>
CAN0 Message Slot 1 Extended ID2 (C0MSL1EID2)	<Address: H'0080 1114>
CAN0 Message Slot 2 Extended ID2 (C0MSL2EID2)	<Address: H'0080 1124>
CAN0 Message Slot 3 Extended ID2 (C0MSL3EID2)	<Address: H'0080 1134>
CAN0 Message Slot 4 Extended ID2 (C0MSL4EID2)	<Address: H'0080 1144>
CAN0 Message Slot 5 Extended ID2 (C0MSL5EID2)	<Address: H'0080 1154>
CAN0 Message Slot 6 Extended ID2 (C0MSL6EID2)	<Address: H'0080 1164>
CAN0 Message Slot 7 Extended ID2 (C0MSL7EID2)	<Address: H'0080 1174>
CAN0 Message Slot 8 Extended ID2 (C0MSL8EID2)	<Address: H'0080 1184>
CAN0 Message Slot 9 Extended ID2 (C0MSL9EID2)	<Address: H'0080 1194>
CAN0 Message Slot 10 Extended ID2 (C0MSL10EID2)	<Address: H'0080 11A4>
CAN0 Message Slot 11 Extended ID2 (C0MSL11EID2)	<Address: H'0080 11B4>
CAN0 Message Slot 12 Extended ID2 (C0MSL12EID2)	<Address: H'0080 11C4>
CAN0 Message Slot 13 Extended ID2 (C0MSL13EID2)	<Address: H'0080 11D4>
CAN0 Message Slot 14 Extended ID2 (C0MSL14EID2)	<Address: H'0080 11E4>
CAN0 Message Slot 15 Extended ID2 (C0MSL15EID2)	<Address: H'0080 11F4>
CAN0 Message Slot 16 Extended ID2 (C0MSL16EID2)	<Address: H'0080 1204>
CAN0 Message Slot 17 Extended ID2 (C0MSL17EID2)	<Address: H'0080 1214>
CAN0 Message Slot 18 Extended ID2 (C0MSL18EID2)	<Address: H'0080 1224>
CAN0 Message Slot 19 Extended ID2 (C0MSL19EID2)	<Address: H'0080 1234>
CAN0 Message Slot 20 Extended ID2 (C0MSL20EID2)	<Address: H'0080 1244>
CAN0 Message Slot 21 Extended ID2 (C0MSL21EID2)	<Address: H'0080 1254>
CAN0 Message Slot 22 Extended ID2 (C0MSL22EID2)	<Address: H'0080 1264>
CAN0 Message Slot 23 Extended ID2 (C0MSL23EID2)	<Address: H'0080 1274>
CAN0 Message Slot 24 Extended ID2 (C0MSL24EID2)	<Address: H'0080 1284>
CAN0 Message Slot 25 Extended ID2 (C0MSL25EID2)	<Address: H'0080 1294>
CAN0 Message Slot 26 Extended ID2 (C0MSL26EID2)	<Address: H'0080 12A4>
CAN0 Message Slot 27 Extended ID2 (C0MSL27EID2)	<Address: H'0080 12B4>
CAN0 Message Slot 28 Extended ID2 (C0MSL28EID2)	<Address: H'0080 12C4>
CAN0 Message Slot 29 Extended ID2 (C0MSL29EID2)	<Address: H'0080 12D4>
CAN0 Message Slot 30 Extended ID2 (C0MSL30EID2)	<Address: H'0080 12E4>
CAN0 Message Slot 31 Extended ID2 (C0MSL31EID2)	<Address: H'0080 12F4>
CAN1 Message Slot 0 Extended ID2 (C1MSL0EID2)	<Address: H'0080 1504>
CAN1 Message Slot 1 Extended ID2 (C1MSL1EID2)	<Address: H'0080 1514>
CAN1 Message Slot 2 Extended ID2 (C1MSL2EID2)	<Address: H'0080 1524>
CAN1 Message Slot 3 Extended ID2 (C1MSL3EID2)	<Address: H'0080 1534>
CAN1 Message Slot 4 Extended ID2 (C1MSL4EID2)	<Address: H'0080 1544>
CAN1 Message Slot 5 Extended ID2 (C1MSL5EID2)	<Address: H'0080 1554>
CAN1 Message Slot 6 Extended ID2 (C1MSL6EID2)	<Address: H'0080 1564>
CAN1 Message Slot 7 Extended ID2 (C1MSL7EID2)	<Address: H'0080 1574>
CAN1 Message Slot 8 Extended ID2 (C1MSL8EID2)	<Address: H'0080 1584>
CAN1 Message Slot 9 Extended ID2 (C1MSL9EID2)	<Address: H'0080 1594>
CAN1 Message Slot 10 Extended ID2 (C1MSL10EID2)	<Address: H'0080 15A4>
CAN1 Message Slot 11 Extended ID2 (C1MSL11EID2)	<Address: H'0080 15B4>
CAN1 Message Slot 12 Extended ID2 (C1MSL12EID2)	<Address: H'0080 15C4>
CAN1 Message Slot 13 Extended ID2 (C1MSL13EID2)	<Address: H'0080 15D4>
CAN1 Message Slot 14 Extended ID2 (C1MSL14EID2)	<Address: H'0080 15E4>
CAN1 Message Slot 15 Extended ID2 (C1MSL15EID2)	<Address: H'0080 15F4>



CAN1 Message Slot 16 Extended ID2 (C1MSL16EID2)	<Address: H'0080 1604>
CAN1 Message Slot 17 Extended ID2 (C1MSL17EID2)	<Address: H'0080 1614>
CAN1 Message Slot 18 Extended ID2 (C1MSL18EID2)	<Address: H'0080 1624>
CAN1 Message Slot 19 Extended ID2 (C1MSL19EID2)	<Address: H'0080 1634>
CAN1 Message Slot 20 Extended ID2 (C1MSL20EID2)	<Address: H'0080 1644>
CAN1 Message Slot 21 Extended ID2 (C1MSL21EID2)	<Address: H'0080 1654>
CAN1 Message Slot 22 Extended ID2 (C1MSL22EID2)	<Address: H'0080 1664>
CAN1 Message Slot 23 Extended ID2 (C1MSL23EID2)	<Address: H'0080 1674>
CAN1 Message Slot 24 Extended ID2 (C1MSL24EID2)	<Address: H'0080 1684>
CAN1 Message Slot 25 Extended ID2 (C1MSL25EID2)	<Address: H'0080 1694>
CAN1 Message Slot 26 Extended ID2 (C1MSL26EID2)	<Address: H'0080 16A4>
CAN1 Message Slot 27 Extended ID2 (C1MSL27EID2)	<Address: H'0080 16B4>
CAN1 Message Slot 28 Extended ID2 (C1MSL28EID2)	<Address: H'0080 16C4>
CAN1 Message Slot 29 Extended ID2 (C1MSL29EID2)	<Address: H'0080 16D4>
CAN1 Message Slot 30 Extended ID2 (C1MSL30EID2)	<Address: H'0080 16E4>
CAN1 Message Slot 31 Extended ID2 (C1MSL31EID2)	<Address: H'0080 16F4>



<Upon exiting reset: Undefined>

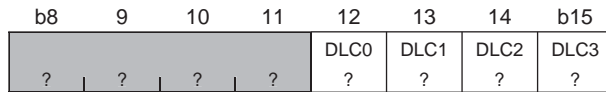
b	Bit Name	Function	R	W
0, 1	No function assigned. Fix to "0."		0	0
2–7	EID12–EID17 (Extended ID12–extended ID17)	Extended ID12–extended ID17	R	W

These registers are the memory space for transmit and receive frames.

Note: • If the message slot is set for the receive slot standard ID format, an undefined value is written to the EID bits when storing received data.

CAN0 Message Slot 0 Data Length Register (C0MSL0DLC)	<Address: H'0080 1105>
CAN0 Message Slot 1 Data Length Register (C0MSL1DLC)	<Address: H'0080 1115>
CAN0 Message Slot 2 Data Length Register (C0MSL2DLC)	<Address: H'0080 1125>
CAN0 Message Slot 3 Data Length Register (C0MSL3DLC)	<Address: H'0080 1135>
CAN0 Message Slot 4 Data Length Register (C0MSL4DLC)	<Address: H'0080 1145>
CAN0 Message Slot 5 Data Length Register (C0MSL5DLC)	<Address: H'0080 1155>
CAN0 Message Slot 6 Data Length Register (C0MSL6DLC)	<Address: H'0080 1165>
CAN0 Message Slot 7 Data Length Register (C0MSL7DLC)	<Address: H'0080 1175>
CAN0 Message Slot 8 Data Length Register (C0MSL8DLC)	<Address: H'0080 1185>
CAN0 Message Slot 9 Data Length Register (C0MSL9DLC)	<Address: H'0080 1195>
CAN0 Message Slot 10 Data Length Register (C0MSL10DLC)	<Address: H'0080 11A5>
CAN0 Message Slot 11 Data Length Register (C0MSL11DLC)	<Address: H'0080 11B5>
CAN0 Message Slot 12 Data Length Register (C0MSL12DLC)	<Address: H'0080 11C5>
CAN0 Message Slot 13 Data Length Register (C0MSL13DLC)	<Address: H'0080 11D5>
CAN0 Message Slot 14 Data Length Register (C0MSL14DLC)	<Address: H'0080 11E5>
CAN0 Message Slot 15 Data Length Register (C0MSL15DLC)	<Address: H'0080 11F5>
CAN0 Message Slot 16 Data Length Register (C0MSL16DLC)	<Address: H'0080 1205>
CAN0 Message Slot 17 Data Length Register (C0MSL17DLC)	<Address: H'0080 1215>
CAN0 Message Slot 18 Data Length Register (C0MSL18DLC)	<Address: H'0080 1225>
CAN0 Message Slot 19 Data Length Register (C0MSL19DLC)	<Address: H'0080 1235>
CAN0 Message Slot 20 Data Length Register (C0MSL20DLC)	<Address: H'0080 1245>
CAN0 Message Slot 21 Data Length Register (C0MSL21DLC)	<Address: H'0080 1255>
CAN0 Message Slot 22 Data Length Register (C0MSL22DLC)	<Address: H'0080 1265>
CAN0 Message Slot 23 Data Length Register (C0MSL23DLC)	<Address: H'0080 1275>
CAN0 Message Slot 24 Data Length Register (C0MSL24DLC)	<Address: H'0080 1285>
CAN0 Message Slot 25 Data Length Register (C0MSL25DLC)	<Address: H'0080 1295>
CAN0 Message Slot 26 Data Length Register (C0MSL26DLC)	<Address: H'0080 12A5>
CAN0 Message Slot 27 Data Length Register (C0MSL27DLC)	<Address: H'0080 12B5>
CAN0 Message Slot 28 Data Length Register (C0MSL28DLC)	<Address: H'0080 12C5>
CAN0 Message Slot 29 Data Length Register (C0MSL29DLC)	<Address: H'0080 12D5>
CAN0 Message Slot 30 Data Length Register (C0MSL30DLC)	<Address: H'0080 12E5>
CAN0 Message Slot 31 Data Length Register (C0MSL31DLC)	<Address: H'0080 12F5>
CAN1 Message Slot 0 Data Length Register (C1MSL0DLC)	<Address: H'0080 1505>
CAN1 Message Slot 1 Data Length Register (C1MSL1DLC)	<Address: H'0080 1515>
CAN1 Message Slot 2 Data Length Register (C1MSL2DLC)	<Address: H'0080 1525>
CAN1 Message Slot 3 Data Length Register (C1MSL3DLC)	<Address: H'0080 1535>
CAN1 Message Slot 4 Data Length Register (C1MSL4DLC)	<Address: H'0080 1545>
CAN1 Message Slot 5 Data Length Register (C1MSL5DLC)	<Address: H'0080 1555>
CAN1 Message Slot 6 Data Length Register (C1MSL6DLC)	<Address: H'0080 1565>
CAN1 Message Slot 7 Data Length Register (C1MSL7DLC)	<Address: H'0080 1575>
CAN1 Message Slot 8 Data Length Register (C1MSL8DLC)	<Address: H'0080 1585>
CAN1 Message Slot 9 Data Length Register (C1MSL9DLC)	<Address: H'0080 1595>
CAN1 Message Slot 10 Data Length Register (C1MSL10DLC)	<Address: H'0080 15A5>
CAN1 Message Slot 11 Data Length Register (C1MSL11DLC)	<Address: H'0080 15B5>
CAN1 Message Slot 12 Data Length Register (C1MSL12DLC)	<Address: H'0080 15C5>
CAN1 Message Slot 13 Data Length Register (C1MSL13DLC)	<Address: H'0080 15D5>
CAN1 Message Slot 14 Data Length Register (C1MSL14DLC)	<Address: H'0080 15E5>
CAN1 Message Slot 15 Data Length Register (C1MSL15DLC)	<Address: H'0080 15F5>

CAN1 Message Slot 16 Data Length Register (C1MSL16DLC)	<Address: H'0080 1605>
CAN1 Message Slot 17 Data Length Register (C1MSL17DLC)	<Address: H'0080 1615>
CAN1 Message Slot 18 Data Length Register (C1MSL18DLC)	<Address: H'0080 1625>
CAN1 Message Slot 19 Data Length Register (C1MSL19DLC)	<Address: H'0080 1635>
CAN1 Message Slot 20 Data Length Register (C1MSL20DLC)	<Address: H'0080 1645>
CAN1 Message Slot 21 Data Length Register (C1MSL21DLC)	<Address: H'0080 1655>
CAN1 Message Slot 22 Data Length Register (C1MSL22DLC)	<Address: H'0080 1665>
CAN1 Message Slot 23 Data Length Register (C1MSL23DLC)	<Address: H'0080 1675>
CAN1 Message Slot 24 Data Length Register (C1MSL24DLC)	<Address: H'0080 1685>
CAN1 Message Slot 25 Data Length Register (C1MSL25DLC)	<Address: H'0080 1695>
CAN1 Message Slot 26 Data Length Register (C1MSL26DLC)	<Address: H'0080 16A5>
CAN1 Message Slot 27 Data Length Register (C1MSL27DLC)	<Address: H'0080 16B5>
CAN1 Message Slot 28 Data Length Register (C1MSL28DLC)	<Address: H'0080 16C5>
CAN1 Message Slot 29 Data Length Register (C1MSL29DLC)	<Address: H'0080 16D5>
CAN1 Message Slot 30 Data Length Register (C1MSL30DLC)	<Address: H'0080 16E5>
CAN1 Message Slot 31 Data Length Register (C1MSL31DLC)	<Address: H'0080 16F5>



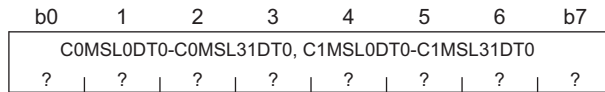
<Upon exiting reset: Undefined>

b	Bit Name	Function	R	W
8–11	No function assigned. Fix to "0."		0	0
12–15	DLC0–DLC3 Data length setting bit	0000: 0 bytes 0001: 1 bytes 0010: 2 bytes 0011: 3 bytes 0100: 4 bytes 0101: 5 bytes 0110: 6 bytes 0111: 7 bytes 1000: 8 bytes     1111: 8 bytes	R	W

These registers are the memory space for transmit and receive frames. When sending, the register is used to set the transmit data length. When receiving, the register is used to store the receive frame DLC.

CAN0 Message Slot 0 Data 0 (COMSL0DT0)	<Address: H'0080 1106>
CAN0 Message Slot 1 Data 0 (COMSL1DT0)	<Address: H'0080 1116>
CAN0 Message Slot 2 Data 0 (COMSL2DT0)	<Address: H'0080 1126>
CAN0 Message Slot 3 Data 0 (COMSL3DT0)	<Address: H'0080 1136>
CAN0 Message Slot 4 Data 0 (COMSL4DT0)	<Address: H'0080 1146>
CAN0 Message Slot 5 Data 0 (COMSL5DT0)	<Address: H'0080 1156>
CAN0 Message Slot 6 Data 0 (COMSL6DT0)	<Address: H'0080 1166>
CAN0 Message Slot 7 Data 0 (COMSL7DT0)	<Address: H'0080 1176>
CAN0 Message Slot 8 Data 0 (COMSL8DT0)	<Address: H'0080 1186>
CAN0 Message Slot 9 Data 0 (COMSL9DT0)	<Address: H'0080 1196>
CAN0 Message Slot 10 Data 0 (COMSL10DT0)	<Address: H'0080 11A6>
CAN0 Message Slot 11 Data 0 (COMSL11DT0)	<Address: H'0080 11B6>
CAN0 Message Slot 12 Data 0 (COMSL12DT0)	<Address: H'0080 11C6>
CAN0 Message Slot 13 Data 0 (COMSL13DT0)	<Address: H'0080 11D6>
CAN0 Message Slot 14 Data 0 (COMSL14DT0)	<Address: H'0080 11E6>
CAN0 Message Slot 15 Data 0 (COMSL15DT0)	<Address: H'0080 11F6>
CAN0 Message Slot 16 Data 0 (COMSL16DT0)	<Address: H'0080 1206>
CAN0 Message Slot 17 Data 0 (COMSL17DT0)	<Address: H'0080 1216>
CAN0 Message Slot 18 Data 0 (COMSL18DT0)	<Address: H'0080 1226>
CAN0 Message Slot 19 Data 0 (COMSL19DT0)	<Address: H'0080 1236>
CAN0 Message Slot 20 Data 0 (COMSL20DT0)	<Address: H'0080 1246>
CAN0 Message Slot 21 Data 0 (COMSL21DT0)	<Address: H'0080 1256>
CAN0 Message Slot 22 Data 0 (COMSL22DT0)	<Address: H'0080 1266>
CAN0 Message Slot 23 Data 0 (COMSL23DT0)	<Address: H'0080 1276>
CAN0 Message Slot 24 Data 0 (COMSL24DT0)	<Address: H'0080 1286>
CAN0 Message Slot 25 Data 0 (COMSL25DT0)	<Address: H'0080 1296>
CAN0 Message Slot 26 Data 0 (COMSL26DT0)	<Address: H'0080 12A6>
CAN0 Message Slot 27 Data 0 (COMSL27DT0)	<Address: H'0080 12B6>
CAN0 Message Slot 28 Data 0 (COMSL28DT0)	<Address: H'0080 12C6>
CAN0 Message Slot 29 Data 0 (COMSL29DT0)	<Address: H'0080 12D6>
CAN0 Message Slot 30 Data 0 (COMSL30DT0)	<Address: H'0080 12E6>
CAN0 Message Slot 31 Data 0 (COMSL31DT0)	<Address: H'0080 12F6>
CAN1 Message Slot 0 Data 0 (C1MSL0DT0)	<Address: H'0080 1506>
CAN1 Message Slot 1 Data 0 (C1MSL1DT0)	<Address: H'0080 1516>
CAN1 Message Slot 2 Data 0 (C1MSL2DT0)	<Address: H'0080 1526>
CAN1 Message Slot 3 Data 0 (C1MSL3DT0)	<Address: H'0080 1536>
CAN1 Message Slot 4 Data 0 (C1MSL4DT0)	<Address: H'0080 1546>
CAN1 Message Slot 5 Data 0 (C1MSL5DT0)	<Address: H'0080 1556>
CAN1 Message Slot 6 Data 0 (C1MSL6DT0)	<Address: H'0080 1566>
CAN1 Message Slot 7 Data 0 (C1MSL7DT0)	<Address: H'0080 1576>
CAN1 Message Slot 8 Data 0 (C1MSL8DT0)	<Address: H'0080 1586>
CAN1 Message Slot 9 Data 0 (C1MSL9DT0)	<Address: H'0080 1596>
CAN1 Message Slot 10 Data 0 (C1MSL10DT0)	<Address: H'0080 15A6>
CAN1 Message Slot 11 Data 0 (C1MSL11DT0)	<Address: H'0080 15B6>
CAN1 Message Slot 12 Data 0 (C1MSL12DT0)	<Address: H'0080 15C6>
CAN1 Message Slot 13 Data 0 (C1MSL13DT0)	<Address: H'0080 15D6>
CAN1 Message Slot 14 Data 0 (C1MSL14DT0)	<Address: H'0080 15E6>
CAN1 Message Slot 15 Data 0 (C1MSL15DT0)	<Address: H'0080 15F6>

CAN1 Message Slot 16 Data 0 (C1MSL16DT0)	<Address: H'0080 1606>
CAN1 Message Slot 17 Data 0 (C1MSL17DT0)	<Address: H'0080 1616>
CAN1 Message Slot 18 Data 0 (C1MSL18DT0)	<Address: H'0080 1626>
CAN1 Message Slot 19 Data 0 (C1MSL19DT0)	<Address: H'0080 1636>
CAN1 Message Slot 20 Data 0 (C1MSL20DT0)	<Address: H'0080 1646>
CAN1 Message Slot 21 Data 0 (C1MSL21DT0)	<Address: H'0080 1656>
CAN1 Message Slot 22 Data 0 (C1MSL22DT0)	<Address: H'0080 1666>
CAN1 Message Slot 23 Data 0 (C1MSL23DT0)	<Address: H'0080 1676>
CAN1 Message Slot 24 Data 0 (C1MSL24DT0)	<Address: H'0080 1686>
CAN1 Message Slot 25 Data 0 (C1MSL25DT0)	<Address: H'0080 1696>
CAN1 Message Slot 26 Data 0 (C1MSL26DT0)	<Address: H'0080 16A6>
CAN1 Message Slot 27 Data 0 (C1MSL27DT0)	<Address: H'0080 16B6>
CAN1 Message Slot 28 Data 0 (C1MSL28DT0)	<Address: H'0080 16C6>
CAN1 Message Slot 29 Data 0 (C1MSL29DT0)	<Address: H'0080 16D6>
CAN1 Message Slot 30 Data 0 (C1MSL30DT0)	<Address: H'0080 16E6>
CAN1 Message Slot 31 Data 0 (C1MSL31DT0)	<Address: H'0080 16F6>



&lt;Upon exiting reset: Undefined&gt;

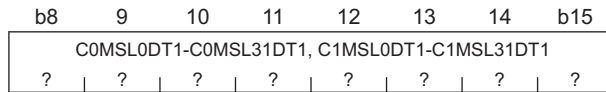
b	Bit Name	Function	R	W
0-7	C0MSL0DT0-C0MSL31DT0, C1MSL0DT0-C1MSL31DT0	Message slot data 0	R	W

These registers are the memory space for transmit and receive frames.

- Notes:
- During a receive slot, an undefined value is written to the register if the data length of the data frame being stored (DLC value) = "0."
  - The first byte of the CAN frame data field corresponds to message slot n data 0. Data is transmitted or received beginning with the MSB side of the register.

CAN0 Message Slot 0 Data 1 (COMSL0DT1)	<Address: H'0080 1107>
CAN0 Message Slot 1 Data 1 (COMSL1DT1)	<Address: H'0080 1117>
CAN0 Message Slot 2 Data 1 (COMSL2DT1)	<Address: H'0080 1127>
CAN0 Message Slot 3 Data 1 (COMSL3DT1)	<Address: H'0080 1137>
CAN0 Message Slot 4 Data 1 (COMSL4DT1)	<Address: H'0080 1147>
CAN0 Message Slot 5 Data 1 (COMSL5DT1)	<Address: H'0080 1157>
CAN0 Message Slot 6 Data 1 (COMSL6DT1)	<Address: H'0080 1167>
CAN0 Message Slot 7 Data 1 (COMSL7DT1)	<Address: H'0080 1177>
CAN0 Message Slot 8 Data 1 (COMSL8DT1)	<Address: H'0080 1187>
CAN0 Message Slot 9 Data 1 (COMSL9DT1)	<Address: H'0080 1197>
CAN0 Message Slot 10 Data 1 (COMSL10DT1)	<Address: H'0080 11A7>
CAN0 Message Slot 11 Data 1 (COMSL11DT1)	<Address: H'0080 11B7>
CAN0 Message Slot 12 Data 1 (COMSL12DT1)	<Address: H'0080 11C7>
CAN0 Message Slot 13 Data 1 (COMSL13DT1)	<Address: H'0080 11D7>
CAN0 Message Slot 14 Data 1 (COMSL14DT1)	<Address: H'0080 11E7>
CAN0 Message Slot 15 Data 1 (COMSL15DT1)	<Address: H'0080 11F7>
CAN0 Message Slot 16 Data 1 (COMSL16DT1)	<Address: H'0080 1207>
CAN0 Message Slot 17 Data 1 (COMSL17DT1)	<Address: H'0080 1217>
CAN0 Message Slot 18 Data 1 (COMSL18DT1)	<Address: H'0080 1227>
CAN0 Message Slot 19 Data 1 (COMSL19DT1)	<Address: H'0080 1237>
CAN0 Message Slot 20 Data 1 (COMSL20DT1)	<Address: H'0080 1247>
CAN0 Message Slot 21 Data 1 (COMSL21DT1)	<Address: H'0080 1257>
CAN0 Message Slot 22 Data 1 (COMSL22DT1)	<Address: H'0080 1267>
CAN0 Message Slot 23 Data 1 (COMSL23DT1)	<Address: H'0080 1277>
CAN0 Message Slot 24 Data 1 (COMSL24DT1)	<Address: H'0080 1287>
CAN0 Message Slot 25 Data 1 (COMSL25DT1)	<Address: H'0080 1297>
CAN0 Message Slot 26 Data 1 (COMSL26DT1)	<Address: H'0080 12A7>
CAN0 Message Slot 27 Data 1 (COMSL27DT1)	<Address: H'0080 12B7>
CAN0 Message Slot 28 Data 1 (COMSL28DT1)	<Address: H'0080 12C7>
CAN0 Message Slot 29 Data 1 (COMSL29DT1)	<Address: H'0080 12D7>
CAN0 Message Slot 30 Data 1 (COMSL30DT1)	<Address: H'0080 12E7>
CAN0 Message Slot 31 Data 1 (COMSL31DT1)	<Address: H'0080 12F7>
CAN1 Message Slot 0 Data 1 (C1MSL0DT1)	<Address: H'0080 1507>
CAN1 Message Slot 1 Data 1 (C1MSL1DT1)	<Address: H'0080 1517>
CAN1 Message Slot 2 Data 1 (C1MSL2DT1)	<Address: H'0080 1527>
CAN1 Message Slot 3 Data 1 (C1MSL3DT1)	<Address: H'0080 1537>
CAN1 Message Slot 4 Data 1 (C1MSL4DT1)	<Address: H'0080 1547>
CAN1 Message Slot 5 Data 1 (C1MSL5DT1)	<Address: H'0080 1557>
CAN1 Message Slot 6 Data 1 (C1MSL6DT1)	<Address: H'0080 1567>
CAN1 Message Slot 7 Data 1 (C1MSL7DT1)	<Address: H'0080 1577>
CAN1 Message Slot 8 Data 1 (C1MSL8DT1)	<Address: H'0080 1587>
CAN1 Message Slot 9 Data 1 (C1MSL9DT1)	<Address: H'0080 1597>
CAN1 Message Slot 10 Data 1 (C1MSL10DT1)	<Address: H'0080 15A7>
CAN1 Message Slot 11 Data 1 (C1MSL11DT1)	<Address: H'0080 15B7>
CAN1 Message Slot 12 Data 1 (C1MSL12DT1)	<Address: H'0080 15C7>
CAN1 Message Slot 13 Data 1 (C1MSL13DT1)	<Address: H'0080 15D7>
CAN1 Message Slot 14 Data 1 (C1MSL14DT1)	<Address: H'0080 15E7>
CAN1 Message Slot 15 Data 1 (C1MSL15DT1)	<Address: H'0080 15F7>

CAN1 Message Slot 16 Data 1 (C1MSL16DT1)	<Address: H'0080 1607>
CAN1 Message Slot 17 Data 1 (C1MSL17DT1)	<Address: H'0080 1617>
CAN1 Message Slot 18 Data 1 (C1MSL18DT1)	<Address: H'0080 1627>
CAN1 Message Slot 19 Data 1 (C1MSL19DT1)	<Address: H'0080 1637>
CAN1 Message Slot 20 Data 1 (C1MSL20DT1)	<Address: H'0080 1647>
CAN1 Message Slot 21 Data 1 (C1MSL21DT1)	<Address: H'0080 1657>
CAN1 Message Slot 22 Data 1 (C1MSL22DT1)	<Address: H'0080 1667>
CAN1 Message Slot 23 Data 1 (C1MSL23DT1)	<Address: H'0080 1677>
CAN1 Message Slot 24 Data 1 (C1MSL24DT1)	<Address: H'0080 1687>
CAN1 Message Slot 25 Data 1 (C1MSL25DT1)	<Address: H'0080 1697>
CAN1 Message Slot 26 Data 1 (C1MSL26DT1)	<Address: H'0080 16A7>
CAN1 Message Slot 27 Data 1 (C1MSL27DT1)	<Address: H'0080 16B7>
CAN1 Message Slot 28 Data 1 (C1MSL28DT1)	<Address: H'0080 16C7>
CAN1 Message Slot 29 Data 1 (C1MSL29DT1)	<Address: H'0080 16D7>
CAN1 Message Slot 30 Data 1 (C1MSL30DT1)	<Address: H'0080 16E7>
CAN1 Message Slot 31 Data 1 (C1MSL31DT1)	<Address: H'0080 16F7>



<Upon exiting reset: Undefined>

b	Bit Name	Function	R	W
8-15	C0MSL0DT1-C0MSL31DT1, C1MSL0DT1-C1MSL31DT1	Message slot data 1	R	W

These registers are the memory space for transmit and receive frames.

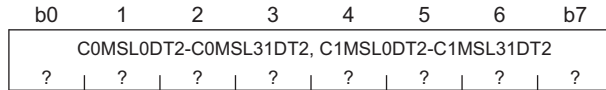
**Note:** • During a receive slot, an undefined value is written to the register if the data length of the data frame being stored (DLC value) is equal to or less than 1.



CAN0 Message Slot 0 Data 2 (COMSL0DT2)	<Address: H'0080 1108>
CAN0 Message Slot 1 Data 2 (COMSL1DT2)	<Address: H'0080 1118>
CAN0 Message Slot 2 Data 2 (COMSL2DT2)	<Address: H'0080 1128>
CAN0 Message Slot 3 Data 2 (COMSL3DT2)	<Address: H'0080 1138>
CAN0 Message Slot 4 Data 2 (COMSL4DT2)	<Address: H'0080 1148>
CAN0 Message Slot 5 Data 2 (COMSL5DT2)	<Address: H'0080 1158>
CAN0 Message Slot 6 Data 2 (COMSL6DT2)	<Address: H'0080 1168>
CAN0 Message Slot 7 Data 2 (COMSL7DT2)	<Address: H'0080 1178>
CAN0 Message Slot 8 Data 2 (COMSL8DT2)	<Address: H'0080 1188>
CAN0 Message Slot 9 Data 2 (COMSL9DT2)	<Address: H'0080 1198>
CAN0 Message Slot 10 Data 2 (COMSL10DT2)	<Address: H'0080 11A8>
CAN0 Message Slot 11 Data 2 (COMSL11DT2)	<Address: H'0080 11B8>
CAN0 Message Slot 12 Data 2 (COMSL12DT2)	<Address: H'0080 11C8>
CAN0 Message Slot 13 Data 2 (COMSL13DT2)	<Address: H'0080 11D8>
CAN0 Message Slot 14 Data 2 (COMSL14DT2)	<Address: H'0080 11E8>
CAN0 Message Slot 15 Data 2 (COMSL15DT2)	<Address: H'0080 11F8>
CAN0 Message Slot 16 Data 2 (COMSL16DT2)	<Address: H'0080 1208>
CAN0 Message Slot 17 Data 2 (COMSL17DT2)	<Address: H'0080 1218>
CAN0 Message Slot 18 Data 2 (COMSL18DT2)	<Address: H'0080 1228>
CAN0 Message Slot 19 Data 2 (COMSL19DT2)	<Address: H'0080 1238>
CAN0 Message Slot 20 Data 2 (COMSL20DT2)	<Address: H'0080 1248>
CAN0 Message Slot 21 Data 2 (COMSL21DT2)	<Address: H'0080 1258>
CAN0 Message Slot 22 Data 2 (COMSL22DT2)	<Address: H'0080 1268>
CAN0 Message Slot 23 Data 2 (COMSL23DT2)	<Address: H'0080 1278>
CAN0 Message Slot 24 Data 2 (COMSL24DT2)	<Address: H'0080 1288>
CAN0 Message Slot 25 Data 2 (COMSL25DT2)	<Address: H'0080 1298>
CAN0 Message Slot 26 Data 2 (COMSL26DT2)	<Address: H'0080 12A8>
CAN0 Message Slot 27 Data 2 (COMSL27DT2)	<Address: H'0080 12B8>
CAN0 Message Slot 28 Data 2 (COMSL28DT2)	<Address: H'0080 12C8>
CAN0 Message Slot 29 Data 2 (COMSL29DT2)	<Address: H'0080 12D8>
CAN0 Message Slot 30 Data 2 (COMSL30DT2)	<Address: H'0080 12E8>
CAN0 Message Slot 31 Data 2 (COMSL31DT2)	<Address: H'0080 12F8>
CAN1 Message Slot 0 Data 2 (C1MSL0DT2)	<Address: H'0080 1508>
CAN1 Message Slot 1 Data 2 (C1MSL1DT2)	<Address: H'0080 1518>
CAN1 Message Slot 2 Data 2 (C1MSL2DT2)	<Address: H'0080 1528>
CAN1 Message Slot 3 Data 2 (C1MSL3DT2)	<Address: H'0080 1538>
CAN1 Message Slot 4 Data 2 (C1MSL4DT2)	<Address: H'0080 1548>
CAN1 Message Slot 5 Data 2 (C1MSL5DT2)	<Address: H'0080 1558>
CAN1 Message Slot 6 Data 2 (C1MSL6DT2)	<Address: H'0080 1568>
CAN1 Message Slot 7 Data 2 (C1MSL7DT2)	<Address: H'0080 1578>
CAN1 Message Slot 8 Data 2 (C1MSL8DT2)	<Address: H'0080 1588>
CAN1 Message Slot 9 Data 2 (C1MSL9DT2)	<Address: H'0080 1598>
CAN1 Message Slot 10 Data 2 (C1MSL10DT2)	<Address: H'0080 15A8>
CAN1 Message Slot 11 Data 2 (C1MSL11DT2)	<Address: H'0080 15B8>
CAN1 Message Slot 12 Data 2 (C1MSL12DT2)	<Address: H'0080 15C8>
CAN1 Message Slot 13 Data 2 (C1MSL13DT2)	<Address: H'0080 15D8>
CAN1 Message Slot 14 Data 2 (C1MSL14DT2)	<Address: H'0080 15E8>
CAN1 Message Slot 15 Data 2 (C1MSL15DT2)	<Address: H'0080 15F8>



CAN1 Message Slot 16 Data 2 (C1MSL16DT2)	<Address: H'0080 1608>
CAN1 Message Slot 17 Data 2 (C1MSL17DT2)	<Address: H'0080 1618>
CAN1 Message Slot 18 Data 2 (C1MSL18DT2)	<Address: H'0080 1628>
CAN1 Message Slot 19 Data 2 (C1MSL19DT2)	<Address: H'0080 1638>
CAN1 Message Slot 20 Data 2 (C1MSL20DT2)	<Address: H'0080 1648>
CAN1 Message Slot 21 Data 2 (C1MSL21DT2)	<Address: H'0080 1658>
CAN1 Message Slot 22 Data 2 (C1MSL22DT2)	<Address: H'0080 1668>
CAN1 Message Slot 23 Data 2 (C1MSL23DT2)	<Address: H'0080 1678>
CAN1 Message Slot 24 Data 2 (C1MSL24DT2)	<Address: H'0080 1688>
CAN1 Message Slot 25 Data 2 (C1MSL25DT2)	<Address: H'0080 1698>
CAN1 Message Slot 26 Data 2 (C1MSL26DT2)	<Address: H'0080 16A8>
CAN1 Message Slot 27 Data 2 (C1MSL27DT2)	<Address: H'0080 16B8>
CAN1 Message Slot 28 Data 2 (C1MSL28DT2)	<Address: H'0080 16C8>
CAN1 Message Slot 29 Data 2 (C1MSL29DT2)	<Address: H'0080 16D8>
CAN1 Message Slot 30 Data 2 (C1MSL30DT2)	<Address: H'0080 16E8>
CAN1 Message Slot 31 Data 2 (C1MSL31DT2)	<Address: H'0080 16F8>



<Upon exiting reset: Undefined>

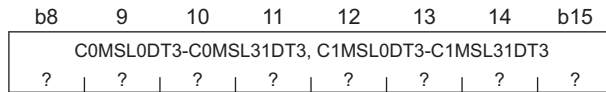
b	Bit Name	Function	R	W
0-7	C0MSL0DT2-C0MSL31DT2, C1MSL0DT2-C1MSL31DT2	Message slot data 2	R	W

These registers are the memory space for transmit and receive frames.

Note: • During a receive slot, an undefined value is written to the register if the data length of the data frame being stored (DLC value) is equal to or less than 2.

CAN0 Message Slot 0 Data 3 (COMSL0DT3)	<Address: H'0080 1109>
CAN0 Message Slot 1 Data 3 (COMSL1DT3)	<Address: H'0080 1119>
CAN0 Message Slot 2 Data 3 (COMSL2DT3)	<Address: H'0080 1129>
CAN0 Message Slot 3 Data 3 (COMSL3DT3)	<Address: H'0080 1139>
CAN0 Message Slot 4 Data 3 (COMSL4DT3)	<Address: H'0080 1149>
CAN0 Message Slot 5 Data 3 (COMSL5DT3)	<Address: H'0080 1159>
CAN0 Message Slot 6 Data 3 (COMSL6DT3)	<Address: H'0080 1169>
CAN0 Message Slot 7 Data 3 (COMSL7DT3)	<Address: H'0080 1179>
CAN0 Message Slot 8 Data 3 (COMSL8DT3)	<Address: H'0080 1189>
CAN0 Message Slot 9 Data 3 (COMSL9DT3)	<Address: H'0080 1199>
CAN0 Message Slot 10 Data 3 (COMSL10DT3)	<Address: H'0080 11A9>
CAN0 Message Slot 11 Data 3 (COMSL11DT3)	<Address: H'0080 11B9>
CAN0 Message Slot 12 Data 3 (COMSL12DT3)	<Address: H'0080 11C9>
CAN0 Message Slot 13 Data 3 (COMSL13DT3)	<Address: H'0080 11D9>
CAN0 Message Slot 14 Data 3 (COMSL14DT3)	<Address: H'0080 11E9>
CAN0 Message Slot 15 Data 3 (COMSL15DT3)	<Address: H'0080 11F9>
CAN0 Message Slot 16 Data 3 (COMSL16DT3)	<Address: H'0080 1209>
CAN0 Message Slot 17 Data 3 (COMSL17DT3)	<Address: H'0080 1219>
CAN0 Message Slot 18 Data 3 (COMSL18DT3)	<Address: H'0080 1229>
CAN0 Message Slot 19 Data 3 (COMSL19DT3)	<Address: H'0080 1239>
CAN0 Message Slot 20 Data 3 (COMSL20DT3)	<Address: H'0080 1249>
CAN0 Message Slot 21 Data 3 (COMSL21DT3)	<Address: H'0080 1259>
CAN0 Message Slot 22 Data 3 (COMSL22DT3)	<Address: H'0080 1269>
CAN0 Message Slot 23 Data 3 (COMSL23DT3)	<Address: H'0080 1279>
CAN0 Message Slot 24 Data 3 (COMSL24DT3)	<Address: H'0080 1289>
CAN0 Message Slot 25 Data 3 (COMSL25DT3)	<Address: H'0080 1299>
CAN0 Message Slot 26 Data 3 (COMSL26DT3)	<Address: H'0080 12A9>
CAN0 Message Slot 27 Data 3 (COMSL27DT3)	<Address: H'0080 12B9>
CAN0 Message Slot 28 Data 3 (COMSL28DT3)	<Address: H'0080 12C9>
CAN0 Message Slot 29 Data 3 (COMSL29DT3)	<Address: H'0080 12D9>
CAN0 Message Slot 30 Data 3 (COMSL30DT3)	<Address: H'0080 12E9>
CAN0 Message Slot 31 Data 3 (COMSL31DT3)	<Address: H'0080 12F9>
CAN1 Message Slot 0 Data 3 (C1MSL0DT3)	<Address: H'0080 1509>
CAN1 Message Slot 1 Data 3 (C1MSL1DT3)	<Address: H'0080 1519>
CAN1 Message Slot 2 Data 3 (C1MSL2DT3)	<Address: H'0080 1529>
CAN1 Message Slot 3 Data 3 (C1MSL3DT3)	<Address: H'0080 1539>
CAN1 Message Slot 4 Data 3 (C1MSL4DT3)	<Address: H'0080 1549>
CAN1 Message Slot 5 Data 3 (C1MSL5DT3)	<Address: H'0080 1559>
CAN1 Message Slot 6 Data 3 (C1MSL6DT3)	<Address: H'0080 1569>
CAN1 Message Slot 7 Data 3 (C1MSL7DT3)	<Address: H'0080 1579>
CAN1 Message Slot 8 Data 3 (C1MSL8DT3)	<Address: H'0080 1589>
CAN1 Message Slot 9 Data 3 (C1MSL9DT3)	<Address: H'0080 1599>
CAN1 Message Slot 10 Data 3 (C1MSL10DT3)	<Address: H'0080 15A9>
CAN1 Message Slot 11 Data 3 (C1MSL11DT3)	<Address: H'0080 15B9>
CAN1 Message Slot 12 Data 3 (C1MSL12DT3)	<Address: H'0080 15C9>
CAN1 Message Slot 13 Data 3 (C1MSL13DT3)	<Address: H'0080 15D9>
CAN1 Message Slot 14 Data 3 (C1MSL14DT3)	<Address: H'0080 15E9>
CAN1 Message Slot 15 Data 3 (C1MSL15DT3)	<Address: H'0080 15F9>

CAN1 Message Slot 16 Data 3 (C1MSL16DT3)	<Address: H'0080 1609>
CAN1 Message Slot 17 Data 3 (C1MSL17DT3)	<Address: H'0080 1619>
CAN1 Message Slot 18 Data 3 (C1MSL18DT3)	<Address: H'0080 1629>
CAN1 Message Slot 19 Data 3 (C1MSL19DT3)	<Address: H'0080 1639>
CAN1 Message Slot 20 Data 3 (C1MSL20DT3)	<Address: H'0080 1649>
CAN1 Message Slot 21 Data 3 (C1MSL21DT3)	<Address: H'0080 1659>
CAN1 Message Slot 22 Data 3 (C1MSL22DT3)	<Address: H'0080 1669>
CAN1 Message Slot 23 Data 3 (C1MSL23DT3)	<Address: H'0080 1679>
CAN1 Message Slot 24 Data 3 (C1MSL24DT3)	<Address: H'0080 1689>
CAN1 Message Slot 25 Data 3 (C1MSL25DT3)	<Address: H'0080 1699>
CAN1 Message Slot 26 Data 3 (C1MSL26DT3)	<Address: H'0080 16A9>
CAN1 Message Slot 27 Data 3 (C1MSL27DT3)	<Address: H'0080 16B9>
CAN1 Message Slot 28 Data 3 (C1MSL28DT3)	<Address: H'0080 16C9>
CAN1 Message Slot 29 Data 3 (C1MSL29DT3)	<Address: H'0080 16D9>
CAN1 Message Slot 30 Data 3 (C1MSL30DT3)	<Address: H'0080 16E9>
CAN1 Message Slot 31 Data 3 (C1MSL31DT3)	<Address: H'0080 16F9>



<Upon exiting reset: Undefined>

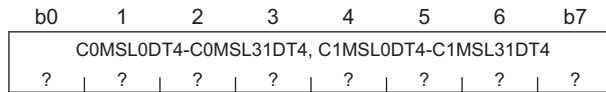
b	Bit Name	Function	R	W
8-15	C0MSL0DT3-C0MSL31DT3, C1MSL0DT3-C1MSL31DT3	Message slot data 3	R	W

These registers are the memory space for transmit and receive frames.

**Note:** • During a receive slot, an undefined value is written to the register if the data length of the data frame being stored (DLC value) is equal to or less than 3.

CAN0 Message Slot 0 Data 4 (COMSL0DT4)	<Address: H'0080 110A>
CAN0 Message Slot 1 Data 4 (COMSL1DT4)	<Address: H'0080 111A>
CAN0 Message Slot 2 Data 4 (COMSL2DT4)	<Address: H'0080 112A>
CAN0 Message Slot 3 Data 4 (COMSL3DT4)	<Address: H'0080 113A>
CAN0 Message Slot 4 Data 4 (COMSL4DT4)	<Address: H'0080 114A>
CAN0 Message Slot 5 Data 4 (COMSL5DT4)	<Address: H'0080 115A>
CAN0 Message Slot 6 Data 4 (COMSL6DT4)	<Address: H'0080 116A>
CAN0 Message Slot 7 Data 4 (COMSL7DT4)	<Address: H'0080 117A>
CAN0 Message Slot 8 Data 4 (COMSL8DT4)	<Address: H'0080 118A>
CAN0 Message Slot 9 Data 4 (COMSL9DT4)	<Address: H'0080 119A>
CAN0 Message Slot 10 Data 4 (COMSL10DT4)	<Address: H'0080 11AA>
CAN0 Message Slot 11 Data 4 (COMSL11DT4)	<Address: H'0080 11BA>
CAN0 Message Slot 12 Data 4 (COMSL12DT4)	<Address: H'0080 11CA>
CAN0 Message Slot 13 Data 4 (COMSL13DT4)	<Address: H'0080 11DA>
CAN0 Message Slot 14 Data 4 (COMSL14DT4)	<Address: H'0080 11EA>
CAN0 Message Slot 15 Data 4 (COMSL15DT4)	<Address: H'0080 11FA>
CAN0 Message Slot 16 Data 4 (COMSL16DT4)	<Address: H'0080 120A>
CAN0 Message Slot 17 Data 4 (COMSL17DT4)	<Address: H'0080 121A>
CAN0 Message Slot 18 Data 4 (COMSL18DT4)	<Address: H'0080 122A>
CAN0 Message Slot 19 Data 4 (COMSL19DT4)	<Address: H'0080 123A>
CAN0 Message Slot 20 Data 4 (COMSL20DT4)	<Address: H'0080 124A>
CAN0 Message Slot 21 Data 4 (COMSL21DT4)	<Address: H'0080 125A>
CAN0 Message Slot 22 Data 4 (COMSL22DT4)	<Address: H'0080 126A>
CAN0 Message Slot 23 Data 4 (COMSL23DT4)	<Address: H'0080 127A>
CAN0 Message Slot 24 Data 4 (COMSL24DT4)	<Address: H'0080 128A>
CAN0 Message Slot 25 Data 4 (COMSL25DT4)	<Address: H'0080 129A>
CAN0 Message Slot 26 Data 4 (COMSL26DT4)	<Address: H'0080 12AA>
CAN0 Message Slot 27 Data 4 (COMSL27DT4)	<Address: H'0080 12BA>
CAN0 Message Slot 28 Data 4 (COMSL28DT4)	<Address: H'0080 12CA>
CAN0 Message Slot 29 Data 4 (COMSL29DT4)	<Address: H'0080 12DA>
CAN0 Message Slot 30 Data 4 (COMSL30DT4)	<Address: H'0080 12EA>
CAN0 Message Slot 31 Data 4 (COMSL31DT4)	<Address: H'0080 12FA>
CAN1 Message Slot 0 Data 4 (C1MSL0DT4)	<Address: H'0080 150A>
CAN1 Message Slot 1 Data 4 (C1MSL1DT4)	<Address: H'0080 151A>
CAN1 Message Slot 2 Data 4 (C1MSL2DT4)	<Address: H'0080 152A>
CAN1 Message Slot 3 Data 4 (C1MSL3DT4)	<Address: H'0080 153A>
CAN1 Message Slot 4 Data 4 (C1MSL4DT4)	<Address: H'0080 154A>
CAN1 Message Slot 5 Data 4 (C1MSL5DT4)	<Address: H'0080 155A>
CAN1 Message Slot 6 Data 4 (C1MSL6DT4)	<Address: H'0080 156A>
CAN1 Message Slot 7 Data 4 (C1MSL7DT4)	<Address: H'0080 157A>
CAN1 Message Slot 8 Data 4 (C1MSL8DT4)	<Address: H'0080 158A>
CAN1 Message Slot 9 Data 4 (C1MSL9DT4)	<Address: H'0080 159A>
CAN1 Message Slot 10 Data 4 (C1MSL10DT4)	<Address: H'0080 15AA>
CAN1 Message Slot 11 Data 4 (C1MSL11DT4)	<Address: H'0080 15BA>
CAN1 Message Slot 12 Data 4 (C1MSL12DT4)	<Address: H'0080 15CA>
CAN1 Message Slot 13 Data 4 (C1MSL13DT4)	<Address: H'0080 15DA>
CAN1 Message Slot 14 Data 4 (C1MSL14DT4)	<Address: H'0080 15EA>
CAN1 Message Slot 15 Data 4 (C1MSL15DT4)	<Address: H'0080 15FA>

CAN1 Message Slot 16 Data 4 (C1MSL16DT4)	<Address: H'0080 160A>
CAN1 Message Slot 17 Data 4 (C1MSL17DT4)	<Address: H'0080 161A>
CAN1 Message Slot 18 Data 4 (C1MSL18DT4)	<Address: H'0080 162A>
CAN1 Message Slot 19 Data 4 (C1MSL19DT4)	<Address: H'0080 163A>
CAN1 Message Slot 20 Data 4 (C1MSL20DT4)	<Address: H'0080 164A>
CAN1 Message Slot 21 Data 4 (C1MSL21DT4)	<Address: H'0080 165A>
CAN1 Message Slot 22 Data 4 (C1MSL22DT4)	<Address: H'0080 166A>
CAN1 Message Slot 23 Data 4 (C1MSL23DT4)	<Address: H'0080 167A>
CAN1 Message Slot 24 Data 4 (C1MSL24DT4)	<Address: H'0080 168A>
CAN1 Message Slot 25 Data 4 (C1MSL25DT4)	<Address: H'0080 169A>
CAN1 Message Slot 26 Data 4 (C1MSL26DT4)	<Address: H'0080 16AA>
CAN1 Message Slot 27 Data 4 (C1MSL27DT4)	<Address: H'0080 16BA>
CAN1 Message Slot 28 Data 4 (C1MSL28DT4)	<Address: H'0080 16CA>
CAN1 Message Slot 29 Data 4 (C1MSL29DT4)	<Address: H'0080 16DA>
CAN1 Message Slot 30 Data 4 (C1MSL30DT4)	<Address: H'0080 16EA>
CAN1 Message Slot 31 Data 4 (C1MSL31DT4)	<Address: H'0080 16FA>



<Upon exiting reset: Undefined>

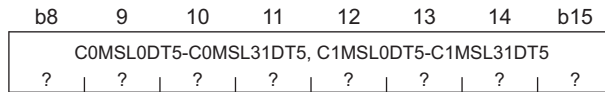
b	Bit Name	Function	R	W
0-7	C0MSL0DT4-C0MSL31DT4, C1MSL0DT4-C1MSL31DT4	Message slot data 4	R	W

These registers are the memory space for transmit and receive frames.

Note: • During a receive slot, an undefined value is written to the register if the data length of the data frame being stored (DLC value) is equal to or less than 4.

CAN0 Message Slot 0 Data 5 (COMSL0DT5)	<Address: H'0080 110B>
CAN0 Message Slot 1 Data 5 (COMSL1DT5)	<Address: H'0080 111B>
CAN0 Message Slot 2 Data 5 (COMSL2DT5)	<Address: H'0080 112B>
CAN0 Message Slot 3 Data 5 (COMSL3DT5)	<Address: H'0080 113B>
CAN0 Message Slot 4 Data 5 (COMSL4DT5)	<Address: H'0080 114B>
CAN0 Message Slot 5 Data 5 (COMSL5DT5)	<Address: H'0080 115B>
CAN0 Message Slot 6 Data 5 (COMSL6DT5)	<Address: H'0080 116B>
CAN0 Message Slot 7 Data 5 (COMSL7DT5)	<Address: H'0080 117B>
CAN0 Message Slot 8 Data 5 (COMSL8DT5)	<Address: H'0080 118B>
CAN0 Message Slot 9 Data 5 (COMSL9DT5)	<Address: H'0080 119B>
CAN0 Message Slot 10 Data 5 (COMSL10DT5)	<Address: H'0080 11AB>
CAN0 Message Slot 11 Data 5 (COMSL11DT5)	<Address: H'0080 11BB>
CAN0 Message Slot 12 Data 5 (COMSL12DT5)	<Address: H'0080 11CB>
CAN0 Message Slot 13 Data 5 (COMSL13DT5)	<Address: H'0080 11DB>
CAN0 Message Slot 14 Data 5 (COMSL14DT5)	<Address: H'0080 11EB>
CAN0 Message Slot 15 Data 5 (COMSL15DT5)	<Address: H'0080 11FB>
CAN0 Message Slot 16 Data 5 (COMSL16DT5)	<Address: H'0080 120B>
CAN0 Message Slot 17 Data 5 (COMSL17DT5)	<Address: H'0080 121B>
CAN0 Message Slot 18 Data 5 (COMSL18DT5)	<Address: H'0080 122B>
CAN0 Message Slot 19 Data 5 (COMSL19DT5)	<Address: H'0080 123B>
CAN0 Message Slot 20 Data 5 (COMSL20DT5)	<Address: H'0080 124B>
CAN0 Message Slot 21 Data 5 (COMSL21DT5)	<Address: H'0080 125B>
CAN0 Message Slot 22 Data 5 (COMSL22DT5)	<Address: H'0080 126B>
CAN0 Message Slot 23 Data 5 (COMSL23DT5)	<Address: H'0080 127B>
CAN0 Message Slot 24 Data 5 (COMSL24DT5)	<Address: H'0080 128B>
CAN0 Message Slot 25 Data 5 (COMSL25DT5)	<Address: H'0080 129B>
CAN0 Message Slot 26 Data 5 (COMSL26DT5)	<Address: H'0080 12AB>
CAN0 Message Slot 27 Data 5 (COMSL27DT5)	<Address: H'0080 12BB>
CAN0 Message Slot 28 Data 5 (COMSL28DT5)	<Address: H'0080 12CB>
CAN0 Message Slot 29 Data 5 (COMSL29DT5)	<Address: H'0080 12DB>
CAN0 Message Slot 30 Data 5 (COMSL30DT5)	<Address: H'0080 12EB>
CAN0 Message Slot 31 Data 5 (COMSL31DT5)	<Address: H'0080 12FB>
CAN1 Message Slot 0 Data 5 (C1MSL0DT5)	<Address: H'0080 150B>
CAN1 Message Slot 1 Data 5 (C1MSL1DT5)	<Address: H'0080 151B>
CAN1 Message Slot 2 Data 5 (C1MSL2DT5)	<Address: H'0080 152B>
CAN1 Message Slot 3 Data 5 (C1MSL3DT5)	<Address: H'0080 153B>
CAN1 Message Slot 4 Data 5 (C1MSL4DT5)	<Address: H'0080 154B>
CAN1 Message Slot 5 Data 5 (C1MSL5DT5)	<Address: H'0080 155B>
CAN1 Message Slot 6 Data 5 (C1MSL6DT5)	<Address: H'0080 156B>
CAN1 Message Slot 7 Data 5 (C1MSL7DT5)	<Address: H'0080 157B>
CAN1 Message Slot 8 Data 5 (C1MSL8DT5)	<Address: H'0080 158B>
CAN1 Message Slot 9 Data 5 (C1MSL9DT5)	<Address: H'0080 159B>
CAN1 Message Slot 10 Data 5 (C1MSL10DT5)	<Address: H'0080 15AB>
CAN1 Message Slot 11 Data 5 (C1MSL11DT5)	<Address: H'0080 15BB>
CAN1 Message Slot 12 Data 5 (C1MSL12DT5)	<Address: H'0080 15CB>
CAN1 Message Slot 13 Data 5 (C1MSL13DT5)	<Address: H'0080 15DB>
CAN1 Message Slot 14 Data 5 (C1MSL14DT5)	<Address: H'0080 15EB>
CAN1 Message Slot 15 Data 5 (C1MSL15DT5)	<Address: H'0080 15FB>

CAN1 Message Slot 16 Data 5 (C1MSL16DT5)	<Address: H'0080 160B>
CAN1 Message Slot 17 Data 5 (C1MSL17DT5)	<Address: H'0080 161B>
CAN1 Message Slot 18 Data 5 (C1MSL18DT5)	<Address: H'0080 162B>
CAN1 Message Slot 19 Data 5 (C1MSL19DT5)	<Address: H'0080 163B>
CAN1 Message Slot 20 Data 5 (C1MSL20DT5)	<Address: H'0080 164B>
CAN1 Message Slot 21 Data 5 (C1MSL21DT5)	<Address: H'0080 165B>
CAN1 Message Slot 22 Data 5 (C1MSL22DT5)	<Address: H'0080 166B>
CAN1 Message Slot 23 Data 5 (C1MSL23DT5)	<Address: H'0080 167B>
CAN1 Message Slot 24 Data 5 (C1MSL24DT5)	<Address: H'0080 168B>
CAN1 Message Slot 25 Data 5 (C1MSL25DT5)	<Address: H'0080 169B>
CAN1 Message Slot 26 Data 5 (C1MSL26DT5)	<Address: H'0080 16AB>
CAN1 Message Slot 27 Data 5 (C1MSL27DT5)	<Address: H'0080 16BB>
CAN1 Message Slot 28 Data 5 (C1MSL28DT5)	<Address: H'0080 16CB>
CAN1 Message Slot 29 Data 5 (C1MSL29DT5)	<Address: H'0080 16DB>
CAN1 Message Slot 30 Data 5 (C1MSL30DT5)	<Address: H'0080 16EB>
CAN1 Message Slot 31 Data 5 (C1MSL31DT5)	<Address: H'0080 16FB>



&lt;Upon exiting reset: Undefined&gt;

b	Bit Name	Function	R	W
8-15	C0MSL0DT5-C0MSL31DT5, C1MSL0DT5-C1MSL31DT5	Message slot data 5	R	W

These registers are the memory space for transmit and receive frames.

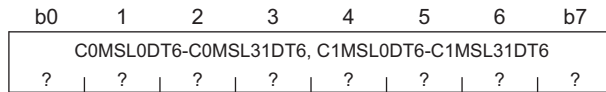
Note: • During a receive slot, an undefined value is written to the register if the data length of the data frame being stored (DLC value) is equal to or less than 5.



CAN0 Message Slot 0 Data 6 (COMSL0DT6)	<Address: H'0080 110C>
CAN0 Message Slot 1 Data 6 (COMSL1DT6)	<Address: H'0080 111C>
CAN0 Message Slot 2 Data 6 (COMSL2DT6)	<Address: H'0080 112C>
CAN0 Message Slot 3 Data 6 (COMSL3DT6)	<Address: H'0080 113C>
CAN0 Message Slot 4 Data 6 (COMSL4DT6)	<Address: H'0080 114C>
CAN0 Message Slot 5 Data 6 (COMSL5DT6)	<Address: H'0080 115C>
CAN0 Message Slot 6 Data 6 (COMSL6DT6)	<Address: H'0080 116C>
CAN0 Message Slot 7 Data 6 (COMSL7DT6)	<Address: H'0080 117C>
CAN0 Message Slot 8 Data 6 (COMSL8DT6)	<Address: H'0080 118C>
CAN0 Message Slot 9 Data 6 (COMSL9DT6)	<Address: H'0080 119C>
CAN0 Message Slot 10 Data 6 (COMSL10DT6)	<Address: H'0080 11AC>
CAN0 Message Slot 11 Data 6 (COMSL11DT6)	<Address: H'0080 11BC>
CAN0 Message Slot 12 Data 6 (COMSL12DT6)	<Address: H'0080 11CC>
CAN0 Message Slot 13 Data 6 (COMSL13DT6)	<Address: H'0080 11DC>
CAN0 Message Slot 14 Data 6 (COMSL14DT6)	<Address: H'0080 11EC>
CAN0 Message Slot 15 Data 6 (COMSL15DT6)	<Address: H'0080 11FC>
CAN0 Message Slot 16 Data 6 (COMSL16DT6)	<Address: H'0080 120C>
CAN0 Message Slot 17 Data 6 (COMSL17DT6)	<Address: H'0080 121C>
CAN0 Message Slot 18 Data 6 (COMSL18DT6)	<Address: H'0080 122C>
CAN0 Message Slot 19 Data 6 (COMSL19DT6)	<Address: H'0080 123C>
CAN0 Message Slot 20 Data 6 (COMSL20DT6)	<Address: H'0080 124C>
CAN0 Message Slot 21 Data 6 (COMSL21DT6)	<Address: H'0080 125C>
CAN0 Message Slot 22 Data 6 (COMSL22DT6)	<Address: H'0080 126C>
CAN0 Message Slot 23 Data 6 (COMSL23DT6)	<Address: H'0080 127C>
CAN0 Message Slot 24 Data 6 (COMSL24DT6)	<Address: H'0080 128C>
CAN0 Message Slot 25 Data 6 (COMSL25DT6)	<Address: H'0080 129C>
CAN0 Message Slot 26 Data 6 (COMSL26DT6)	<Address: H'0080 12AC>
CAN0 Message Slot 27 Data 6 (COMSL27DT6)	<Address: H'0080 12BC>
CAN0 Message Slot 28 Data 6 (COMSL28DT6)	<Address: H'0080 12CC>
CAN0 Message Slot 29 Data 6 (COMSL29DT6)	<Address: H'0080 12DC>
CAN0 Message Slot 30 Data 6 (COMSL30DT6)	<Address: H'0080 12EC>
CAN0 Message Slot 31 Data 6 (COMSL31DT6)	<Address: H'0080 12FC>
CAN1 Message Slot 0 Data 6 (C1MSL0DT6)	<Address: H'0080 150C>
CAN1 Message Slot 1 Data 6 (C1MSL1DT6)	<Address: H'0080 151C>
CAN1 Message Slot 2 Data 6 (C1MSL2DT6)	<Address: H'0080 152C>
CAN1 Message Slot 3 Data 6 (C1MSL3DT6)	<Address: H'0080 153C>
CAN1 Message Slot 4 Data 6 (C1MSL4DT6)	<Address: H'0080 154C>
CAN1 Message Slot 5 Data 6 (C1MSL5DT6)	<Address: H'0080 155C>
CAN1 Message Slot 6 Data 6 (C1MSL6DT6)	<Address: H'0080 156C>
CAN1 Message Slot 7 Data 6 (C1MSL7DT6)	<Address: H'0080 157C>
CAN1 Message Slot 8 Data 6 (C1MSL8DT6)	<Address: H'0080 158C>
CAN1 Message Slot 9 Data 6 (C1MSL9DT6)	<Address: H'0080 159C>
CAN1 Message Slot 10 Data 6 (C1MSL10DT6)	<Address: H'0080 15AC>
CAN1 Message Slot 11 Data 6 (C1MSL11DT6)	<Address: H'0080 15BC>
CAN1 Message Slot 12 Data 6 (C1MSL12DT6)	<Address: H'0080 15CC>
CAN1 Message Slot 13 Data 6 (C1MSL13DT6)	<Address: H'0080 15DC>
CAN1 Message Slot 14 Data 6 (C1MSL14DT6)	<Address: H'0080 15EC>
CAN1 Message Slot 15 Data 6 (C1MSL15DT6)	<Address: H'0080 15FC>



CAN1 Message Slot 16 Data 6 (C1MSL16DT6)	<Address: H'0080 160C>
CAN1 Message Slot 17 Data 6 (C1MSL17DT6)	<Address: H'0080 161C>
CAN1 Message Slot 18 Data 6 (C1MSL18DT6)	<Address: H'0080 162C>
CAN1 Message Slot 19 Data 6 (C1MSL19DT6)	<Address: H'0080 163C>
CAN1 Message Slot 20 Data 6 (C1MSL20DT6)	<Address: H'0080 164C>
CAN1 Message Slot 21 Data 6 (C1MSL21DT6)	<Address: H'0080 165C>
CAN1 Message Slot 22 Data 6 (C1MSL22DT6)	<Address: H'0080 166C>
CAN1 Message Slot 23 Data 6 (C1MSL23DT6)	<Address: H'0080 167C>
CAN1 Message Slot 24 Data 6 (C1MSL24DT6)	<Address: H'0080 168C>
CAN1 Message Slot 25 Data 6 (C1MSL25DT6)	<Address: H'0080 169C>
CAN1 Message Slot 26 Data 6 (C1MSL26DT6)	<Address: H'0080 16AC>
CAN1 Message Slot 27 Data 6 (C1MSL27DT6)	<Address: H'0080 16BC>
CAN1 Message Slot 28 Data 6 (C1MSL28DT6)	<Address: H'0080 16CC>
CAN1 Message Slot 29 Data 6 (C1MSL29DT6)	<Address: H'0080 16DC>
CAN1 Message Slot 30 Data 6 (C1MSL30DT6)	<Address: H'0080 16EC>
CAN1 Message Slot 31 Data 6 (C1MSL31DT6)	<Address: H'0080 16FC>



<Upon exiting reset: Undefined>

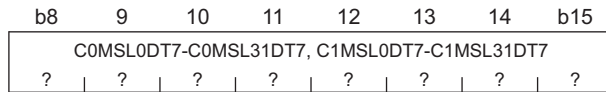
b	Bit Name	Function	R	W
0-7	C0MSL0DT6-C0MSL31DT6, C1MSL0DT6-C1MSL31DT6	Message slot data 6	R	W

These registers are the memory space for transmit and receive frames.

Note: • During a receive slot, an undefined value is written to the register if the data length of the data frame being stored (DLC value) is equal to or less than 6.

CAN0 Message Slot 0 Data 7 (C0MSL0DT7)	<Address: H'0080 110D>
CAN0 Message Slot 1 Data 7 (C0MSL1DT7)	<Address: H'0080 111D>
CAN0 Message Slot 2 Data 7 (C0MSL2DT7)	<Address: H'0080 112D>
CAN0 Message Slot 3 Data 7 (C0MSL3DT7)	<Address: H'0080 113D>
CAN0 Message Slot 4 Data 7 (C0MSL4DT7)	<Address: H'0080 114D>
CAN0 Message Slot 5 Data 7 (C0MSL5DT7)	<Address: H'0080 115D>
CAN0 Message Slot 6 Data 7 (C0MSL6DT7)	<Address: H'0080 116D>
CAN0 Message Slot 7 Data 7 (C0MSL7DT7)	<Address: H'0080 117D>
CAN0 Message Slot 8 Data 7 (C0MSL8DT7)	<Address: H'0080 118D>
CAN0 Message Slot 9 Data 7 (C0MSL9DT7)	<Address: H'0080 119D>
CAN0 Message Slot 10 Data 7 (C0MSL10DT7)	<Address: H'0080 11AD>
CAN0 Message Slot 11 Data 7 (C0MSL11DT7)	<Address: H'0080 11BD>
CAN0 Message Slot 12 Data 7 (C0MSL12DT7)	<Address: H'0080 11CD>
CAN0 Message Slot 13 Data 7 (C0MSL13DT7)	<Address: H'0080 11DD>
CAN0 Message Slot 14 Data 7 (C0MSL14DT7)	<Address: H'0080 11ED>
CAN0 Message Slot 15 Data 7 (C0MSL15DT7)	<Address: H'0080 11FD>
CAN0 Message Slot 16 Data 7 (C0MSL16DT7)	<Address: H'0080 120D>
CAN0 Message Slot 17 Data 7 (C0MSL17DT7)	<Address: H'0080 121D>
CAN0 Message Slot 18 Data 7 (C0MSL18DT7)	<Address: H'0080 122D>
CAN0 Message Slot 19 Data 7 (C0MSL19DT7)	<Address: H'0080 123D>
CAN0 Message Slot 20 Data 7 (C0MSL20DT7)	<Address: H'0080 124D>
CAN0 Message Slot 21 Data 7 (C0MSL21DT7)	<Address: H'0080 125D>
CAN0 Message Slot 22 Data 7 (C0MSL22DT7)	<Address: H'0080 126D>
CAN0 Message Slot 23 Data 7 (C0MSL23DT7)	<Address: H'0080 127D>
CAN0 Message Slot 24 Data 7 (C0MSL24DT7)	<Address: H'0080 128D>
CAN0 Message Slot 25 Data 7 (C0MSL25DT7)	<Address: H'0080 129D>
CAN0 Message Slot 26 Data 7 (C0MSL26DT7)	<Address: H'0080 12AD>
CAN0 Message Slot 27 Data 7 (C0MSL27DT7)	<Address: H'0080 12BD>
CAN0 Message Slot 28 Data 7 (C0MSL28DT7)	<Address: H'0080 12CD>
CAN0 Message Slot 29 Data 7 (C0MSL29DT7)	<Address: H'0080 12DD>
CAN0 Message Slot 30 Data 7 (C0MSL30DT7)	<Address: H'0080 12ED>
CAN0 Message Slot 31 Data 7 (C0MSL31DT7)	<Address: H'0080 12FD>
CAN1 Message Slot 0 Data 7 (C1MSL0DT7)	<Address: H'0080 150D>
CAN1 Message Slot 1 Data 7 (C1MSL1DT7)	<Address: H'0080 151D>
CAN1 Message Slot 2 Data 7 (C1MSL2DT7)	<Address: H'0080 152D>
CAN1 Message Slot 3 Data 7 (C1MSL3DT7)	<Address: H'0080 153D>
CAN1 Message Slot 4 Data 7 (C1MSL4DT7)	<Address: H'0080 154D>
CAN1 Message Slot 5 Data 7 (C1MSL5DT7)	<Address: H'0080 155D>
CAN1 Message Slot 6 Data 7 (C1MSL6DT7)	<Address: H'0080 156D>
CAN1 Message Slot 7 Data 7 (C1MSL7DT7)	<Address: H'0080 157D>
CAN1 Message Slot 8 Data 7 (C1MSL8DT7)	<Address: H'0080 158D>
CAN1 Message Slot 9 Data 7 (C1MSL9DT7)	<Address: H'0080 159D>
CAN1 Message Slot 10 Data 7 (C1MSL10DT7)	<Address: H'0080 15AD>
CAN1 Message Slot 11 Data 7 (C1MSL11DT7)	<Address: H'0080 15BD>
CAN1 Message Slot 12 Data 7 (C1MSL12DT7)	<Address: H'0080 15CD>
CAN1 Message Slot 13 Data 7 (C1MSL13DT7)	<Address: H'0080 15DD>
CAN1 Message Slot 14 Data 7 (C1MSL14DT7)	<Address: H'0080 15ED>
CAN1 Message Slot 15 Data 7 (C1MSL15DT7)	<Address: H'0080 15FD>

CAN1 Message Slot 16 Data 7 (C1MSL16DT7)	<Address: H'0080 160D>
CAN1 Message Slot 17 Data 7 (C1MSL17DT7)	<Address: H'0080 161D>
CAN1 Message Slot 18 Data 7 (C1MSL18DT7)	<Address: H'0080 162D>
CAN1 Message Slot 19 Data 7 (C1MSL19DT7)	<Address: H'0080 163D>
CAN1 Message Slot 20 Data 7 (C1MSL20DT7)	<Address: H'0080 164D>
CAN1 Message Slot 21 Data 7 (C1MSL21DT7)	<Address: H'0080 165D>
CAN1 Message Slot 22 Data 7 (C1MSL22DT7)	<Address: H'0080 166D>
CAN1 Message Slot 23 Data 7 (C1MSL23DT7)	<Address: H'0080 167D>
CAN1 Message Slot 24 Data 7 (C1MSL24DT7)	<Address: H'0080 168D>
CAN1 Message Slot 25 Data 7 (C1MSL25DT7)	<Address: H'0080 169D>
CAN1 Message Slot 26 Data 7 (C1MSL26DT7)	<Address: H'0080 16AD>
CAN1 Message Slot 27 Data 7 (C1MSL27DT7)	<Address: H'0080 16BD>
CAN1 Message Slot 28 Data 7 (C1MSL28DT7)	<Address: H'0080 16CD>
CAN1 Message Slot 29 Data 7 (C1MSL29DT7)	<Address: H'0080 16DD>
CAN1 Message Slot 30 Data 7 (C1MSL30DT7)	<Address: H'0080 16ED>
CAN1 Message Slot 31 Data 7 (C1MSL31DT7)	<Address: H'0080 16FD>



<Upon exiting reset: Undefined>

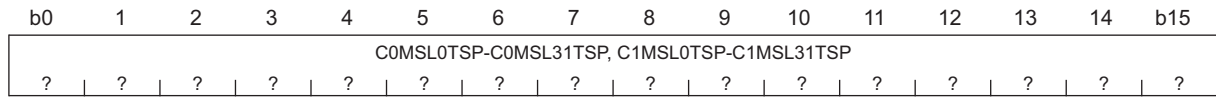
b	Bit Name	Function	R	W
8-15	C0MSL0DT7-C0MSL31DT7, C1MSL0DT7-C1MSL31DT7	Message slot data 7	R	W

These registers are the memory space for transmit and receive frames.

Note: • During a receive slot, an undefined value is written to the register if the data length of the data frame being stored (DLC value) is equal to or less than 7.

CAN0 Message Slot 0 Timestamp (COMSL0TSP)	<Address: H'0080 110E>
CAN0 Message Slot 1 Timestamp (COMSL1TSP)	<Address: H'0080 111E>
CAN0 Message Slot 2 Timestamp (COMSL2TSP)	<Address: H'0080 112E>
CAN0 Message Slot 3 Timestamp (COMSL3TSP)	<Address: H'0080 113E>
CAN0 Message Slot 4 Timestamp (COMSL4TSP)	<Address: H'0080 114E>
CAN0 Message Slot 5 Timestamp (COMSL5TSP)	<Address: H'0080 115E>
CAN0 Message Slot 6 Timestamp (COMSL6TSP)	<Address: H'0080 116E>
CAN0 Message Slot 7 Timestamp (COMSL7TSP)	<Address: H'0080 117E>
CAN0 Message Slot 8 Timestamp (COMSL8TSP)	<Address: H'0080 118E>
CAN0 Message Slot 9 Timestamp (COMSL9TSP)	<Address: H'0080 119E>
CAN0 Message Slot 10 Timestamp (COMSL10TSP)	<Address: H'0080 11AE>
CAN0 Message Slot 11 Timestamp (COMSL11TSP)	<Address: H'0080 11BE>
CAN0 Message Slot 12 Timestamp (COMSL12TSP)	<Address: H'0080 11CE>
CAN0 Message Slot 13 Timestamp (COMSL13TSP)	<Address: H'0080 11DE>
CAN0 Message Slot 14 Timestamp (COMSL14TSP)	<Address: H'0080 11EE>
CAN0 Message Slot 15 Timestamp (COMSL15TSP)	<Address: H'0080 11FE>
CAN0 Message Slot 16 Timestamp (COMSL16TSP)	<Address: H'0080 120E>
CAN0 Message Slot 17 Timestamp (COMSL17TSP)	<Address: H'0080 121E>
CAN0 Message Slot 18 Timestamp (COMSL18TSP)	<Address: H'0080 122E>
CAN0 Message Slot 19 Timestamp (COMSL19TSP)	<Address: H'0080 123E>
CAN0 Message Slot 20 Timestamp (COMSL20TSP)	<Address: H'0080 124E>
CAN0 Message Slot 21 Timestamp (COMSL21TSP)	<Address: H'0080 125E>
CAN0 Message Slot 22 Timestamp (COMSL22TSP)	<Address: H'0080 126E>
CAN0 Message Slot 23 Timestamp (COMSL23TSP)	<Address: H'0080 127E>
CAN0 Message Slot 24 Timestamp (COMSL24TSP)	<Address: H'0080 128E>
CAN0 Message Slot 25 Timestamp (COMSL25TSP)	<Address: H'0080 129E>
CAN0 Message Slot 26 Timestamp (COMSL26TSP)	<Address: H'0080 12AE>
CAN0 Message Slot 27 Timestamp (COMSL27TSP)	<Address: H'0080 12BE>
CAN0 Message Slot 28 Timestamp (COMSL28TSP)	<Address: H'0080 12CE>
CAN0 Message Slot 29 Timestamp (COMSL29TSP)	<Address: H'0080 12DE>
CAN0 Message Slot 30 Timestamp (COMSL30TSP)	<Address: H'0080 12EE>
CAN0 Message Slot 31 Timestamp (COMSL31TSP)	<Address: H'0080 12FE>
CAN1 Message Slot 0 Timestamp (C1MSL0TSP)	<Address: H'0080 150E>
CAN1 Message Slot 1 Timestamp (C1MSL1TSP)	<Address: H'0080 151E>
CAN1 Message Slot 2 Timestamp (C1MSL2TSP)	<Address: H'0080 152E>
CAN1 Message Slot 3 Timestamp (C1MSL3TSP)	<Address: H'0080 153E>
CAN1 Message Slot 4 Timestamp (C1MSL4TSP)	<Address: H'0080 154E>
CAN1 Message Slot 5 Timestamp (C1MSL5TSP)	<Address: H'0080 155E>
CAN1 Message Slot 6 Timestamp (C1MSL6TSP)	<Address: H'0080 156E>
CAN1 Message Slot 7 Timestamp (C1MSL7TSP)	<Address: H'0080 157E>
CAN1 Message Slot 8 Timestamp (C1MSL8TSP)	<Address: H'0080 158E>
CAN1 Message Slot 9 Timestamp (C1MSL9TSP)	<Address: H'0080 159E>
CAN1 Message Slot 10 Timestamp (C1MSL10TSP)	<Address: H'0080 15AE>
CAN1 Message Slot 11 Timestamp (C1MSL11TSP)	<Address: H'0080 15BE>
CAN1 Message Slot 12 Timestamp (C1MSL12TSP)	<Address: H'0080 15CE>
CAN1 Message Slot 13 Timestamp (C1MSL13TSP)	<Address: H'0080 15DE>
CAN1 Message Slot 14 Timestamp (C1MSL14TSP)	<Address: H'0080 15EE>
CAN1 Message Slot 15 Timestamp (C1MSL15TSP)	<Address: H'0080 15FE>

CAN1 Message Slot 16 Timestamp (C1MSL16TSP)	<Address: H'0080 160E>
CAN1 Message Slot 17 Timestamp (C1MSL17TSP)	<Address: H'0080 161E>
CAN1 Message Slot 18 Timestamp (C1MSL18TSP)	<Address: H'0080 162E>
CAN1 Message Slot 19 Timestamp (C1MSL19TSP)	<Address: H'0080 163E>
CAN1 Message Slot 20 Timestamp (C1MSL20TSP)	<Address: H'0080 164E>
CAN1 Message Slot 21 Timestamp (C1MSL21TSP)	<Address: H'0080 165E>
CAN1 Message Slot 22 Timestamp (C1MSL22TSP)	<Address: H'0080 166E>
CAN1 Message Slot 23 Timestamp (C1MSL23TSP)	<Address: H'0080 167E>
CAN1 Message Slot 24 Timestamp (C1MSL24TSP)	<Address: H'0080 168E>
CAN1 Message Slot 25 Timestamp (C1MSL25TSP)	<Address: H'0080 169E>
CAN1 Message Slot 26 Timestamp (C1MSL26TSP)	<Address: H'0080 16AE>
CAN1 Message Slot 27 Timestamp (C1MSL27TSP)	<Address: H'0080 16BE>
CAN1 Message Slot 28 Timestamp (C1MSL28TSP)	<Address: H'0080 16CE>
CAN1 Message Slot 29 Timestamp (C1MSL29TSP)	<Address: H'0080 16DE>
CAN1 Message Slot 30 Timestamp (C1MSL30TSP)	<Address: H'0080 16EE>
CAN1 Message Slot 31 Timestamp (C1MSL31TSP)	<Address: H'0080 16FE>



<Upon exiting reset: Undefined>

b	Bit Name	Function	R	W
0-15	C0MSL0TSP-C0MSL31TSP, C1MSL0TSP-C1MSL31TSP	Message slot timestamp	R	W

These registers are the memory space for transmit and receive frames. When transmission/reception has finished, the CAN timestamp count register value is written to the register.

## 13.3 CAN Protocol

### 13.3.1 CAN Protocol Frames

There are four types of frames that are handled by CAN protocol:

- (1) Data frame
- (2) Remote frame
- (3) Error frame
- (4) Overload frame

Frames are separated from each other by an interframe space.

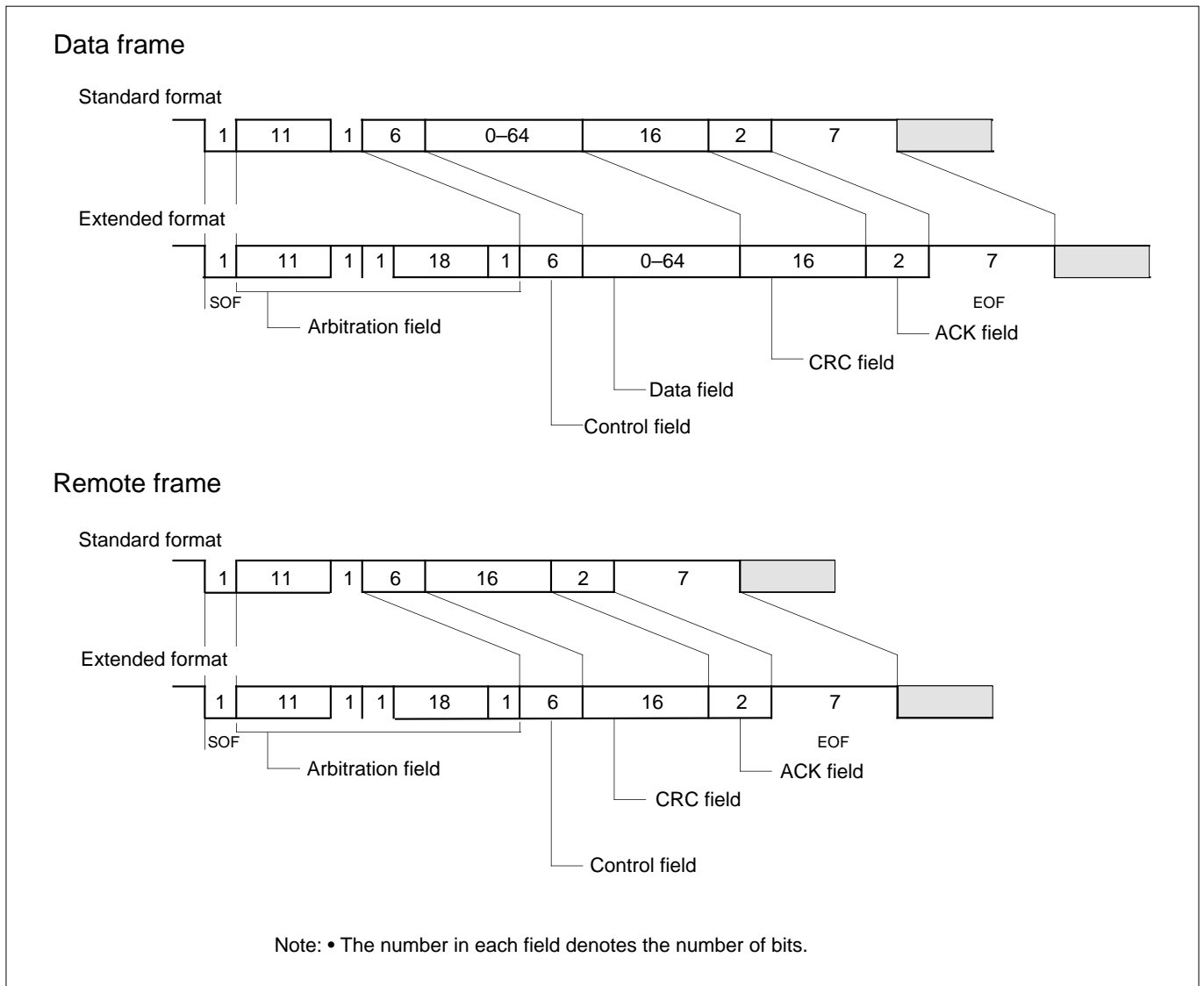
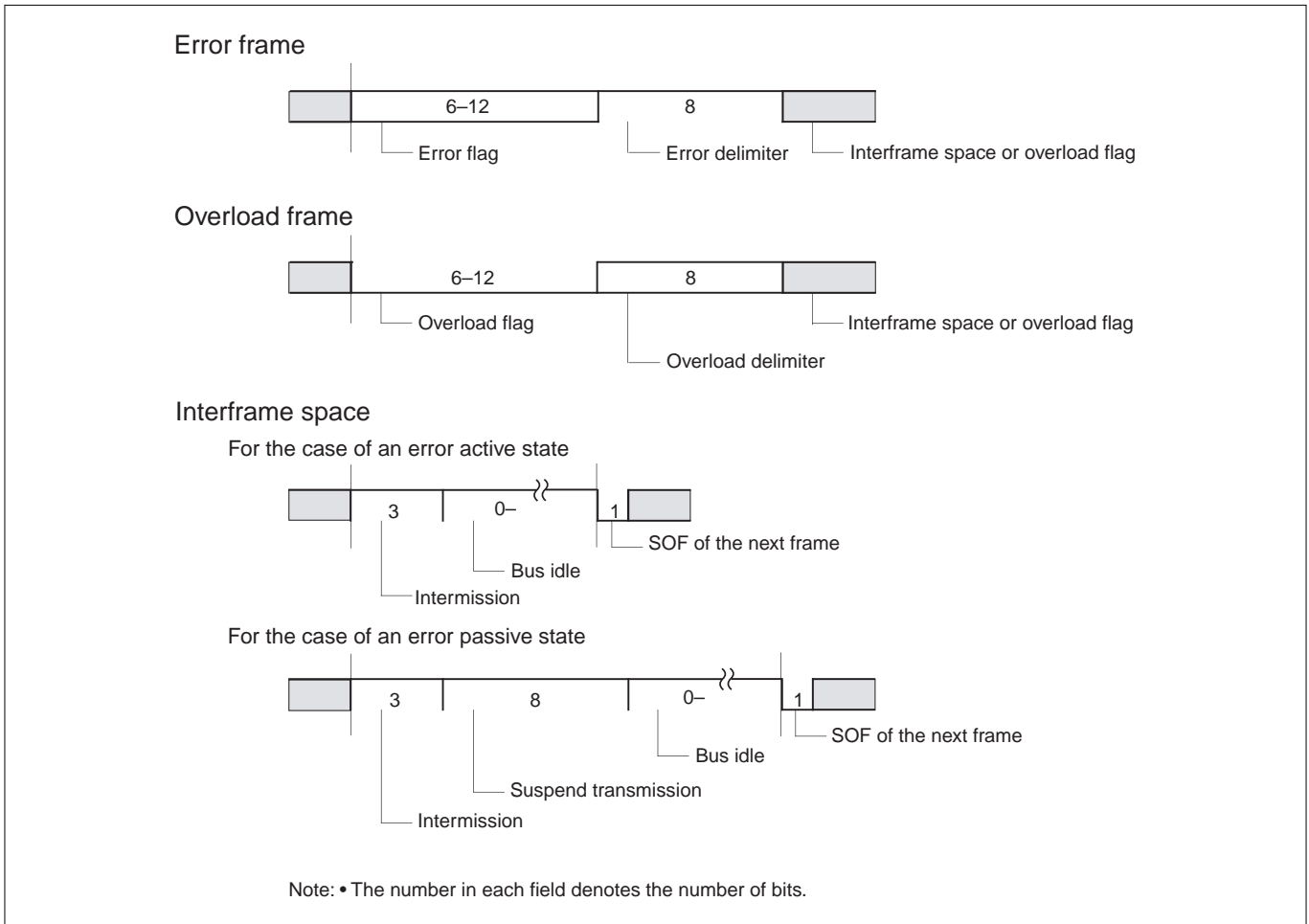


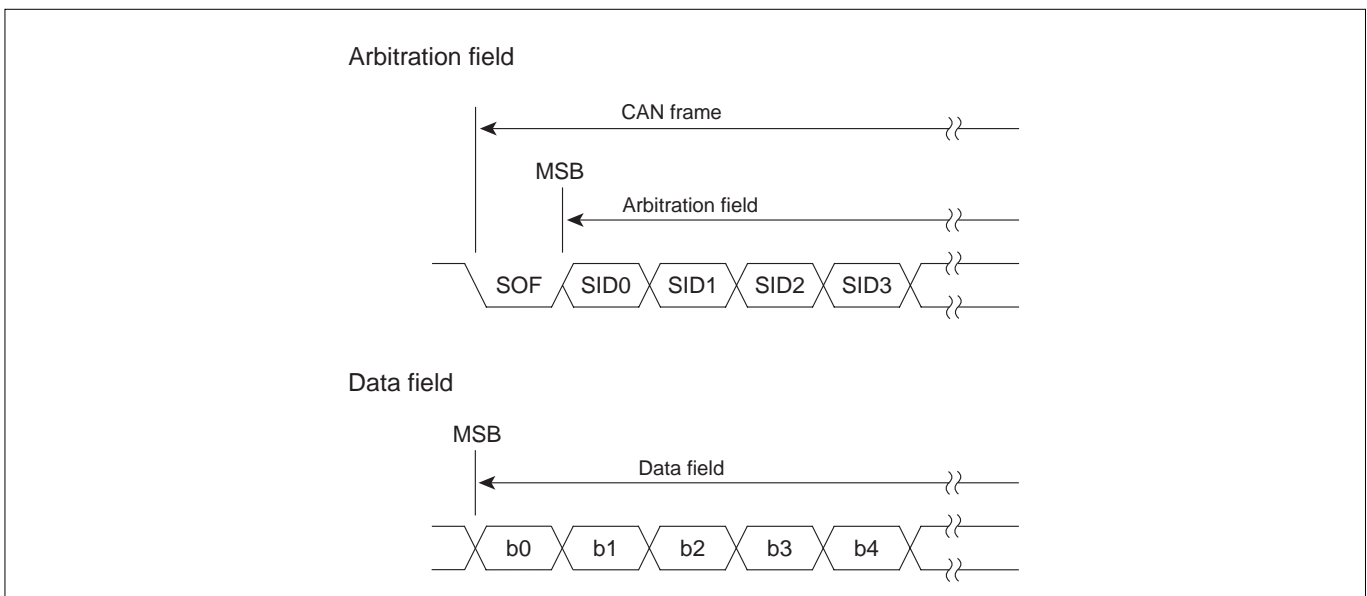
Figure 13.3.1 CAN Protocol Frames (1)



**Figure 13.3.2 CAN Protocol Frames (2)**

### 13.3.2 Data Formats during CAN Transmission/Reception

Figure 13.3.3 shows an example of the transmit/receive transfer data format that can be used in CAN. Data is transmitted/received sequentially beginning with the MSB side of the CAN message slot (C0MSLnSID0-C0MSLnDT7 and C1MSLnSID0-C1MSLnDT7).



**Figure 13.3.3 Example of CAN Transmit/Receive Transfer Data Format**

### 13.3.3 CAN Controller Error States

The CAN controller assumes one of the following three error states depending on the transmit error and receive error counter values.

#### (1) Error active state

- This is a state where almost no errors have occurred.
- When an error is detected, an active error flag is transmitted.
- The CAN controller is in the state immediately after being initialized.

#### (2) Error passive state

- This is a state where many errors have occurred.
- When an error is detected, a passive error flag is transmitted.

#### (3) Bus off state

- This is a state where a very large number of errors have occurred.
- CAN communication with other nodes cannot be performed until the CAN module returns to an error active state.

Error Status of the Unit	Transmit Error Counter		Receive Error Counter
Error active state	0–127	AND	0–127
Error passive state	128–255	OR	128 and over
Bus off state	256 and over		–

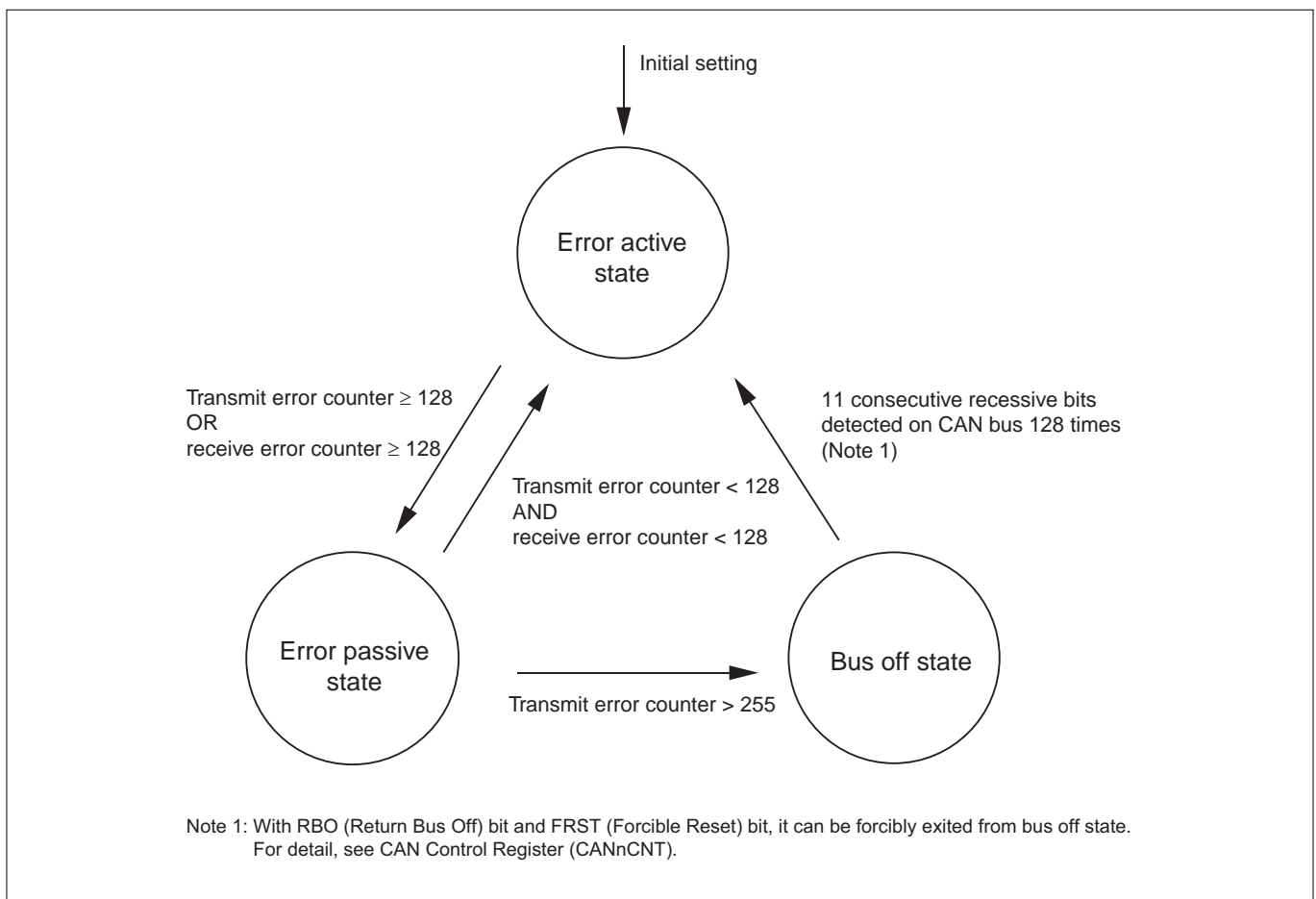


Figure 13.3.4 CAN Controller Error States



## 13.4 Initializing the CAN Module

### 13.4.1 Initializing the CAN Module

Before performing communication, set up the CAN module as described below.

#### (1) Selecting pin functions

The CAN transmit data output pin (CTX) and CAN receive data input pin (CRX) are shared with input/output ports. Be sure to select the functions of these pins. (See Chapter 8, "Input/Output Ports and Pin Functions.")

#### (2) Setting the Interrupt Controller (ICU)

To use CAN module interrupts, set their interrupt priority levels.

#### (3) Setting CAN Error, CAN Single-Shot and CAN Slot Interrupt Request Mask Registers

To use CAN bus error, CAN error passive, CAN error bus off, CAN single-shot or CAN slot interrupts, set each corresponding bit to "1" to enable the interrupt request.

#### (4) Setting DMAC

To use DMA transfers by CAN, be sure to set the DMAC.

#### (5) Setting CAN DMA transfer request select register

To use DMA transfers by CAN, set the CAN DMA transfer request select register to choose the cause of transfer request.

#### (6) Setting CAN module clock

Set clock supplied for protocol engine block of CAN module.

After confirmation for the status of reset CAN module, select CPUCLK/4 in CANx Clock.

#### (7) Setting the bit timing and the number of times sampled

Using the CAN Configuration Register and CAN Baud Rate Prescaler, set the bit timing and the number of times the CAN bus is sampled.

##### 1) Setting the bit timing

Determine the period  $T_q$  that is the base of bit timing, the configuration of Propagation Segment, Phase Segment1 and Phase Segment2, and reSynchronization Jump Width. The equation to calculate  $T_q$  is given below.

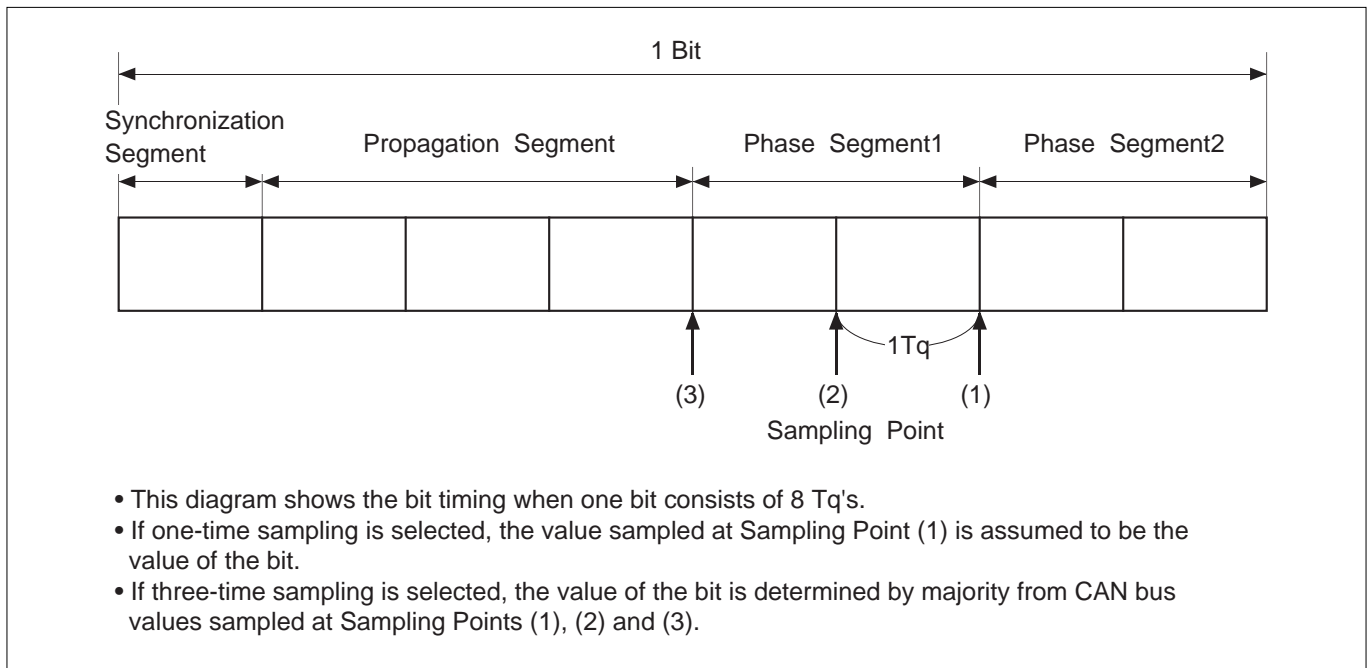
$$T_q \text{ period} = (\text{BRP} + 1) / (\text{CPUCLK}/4)$$

The baud rate is determined by the number of  $T_q$ 's that comprise one bit. The equation to calculate the baud rate is given below.

$$\text{Baud rate (bps)} = \frac{1}{T_q \text{ period} \times \text{number of } T_q \text{ in one bit}}$$

$$\text{Number of } T_q \text{'s in one bit} = \text{Synchronization Segment} + \text{Propagation Segment} + \text{Phase Segment 1} + \text{Phase Segment 2}$$

Note: • The maximum baud rate for communication depends on the system configuration (e.g., bus length, clock error, CAN bus transceiver, sampling position and bit configuration). Consider the system configuration when setting the baud rate and number of  $T_q$ .



**Figure 13.4.1 Example of Bit Timing**

## 2) Setting the number of times sampled

Select the number of times the CAN bus is sampled from “one time” and “three times.”

- If one-time sampling is selected, the value sampled at only the end of Phase Segment1 is assumed to be the value of the bit.
- If three-time sampling is selected, the value of the bit is determined by majority from three sampled values, one sampled at the end of Phase Segment1 and the other sampled 1 Tq before and 2 Tq's before that.

## (8) Setting the ID mask registers

Set the values of ID mask registers (Global Mask Register, Local Mask Register A and Local Mask Register B) that are used in acceptance filtering of received messages.

## (9) Settings for use in BasicCAN mode

- Set the CAN Frame Format Select Register IDE30 and IDE31 bits. (We recommend setting the same value in these bits.)
- Set IDs in message slots 30 and 31.
- Set the Message Control Registers 30 and 31 for data frame reception (H'40).

## (10) Settings for use in single-shot mode

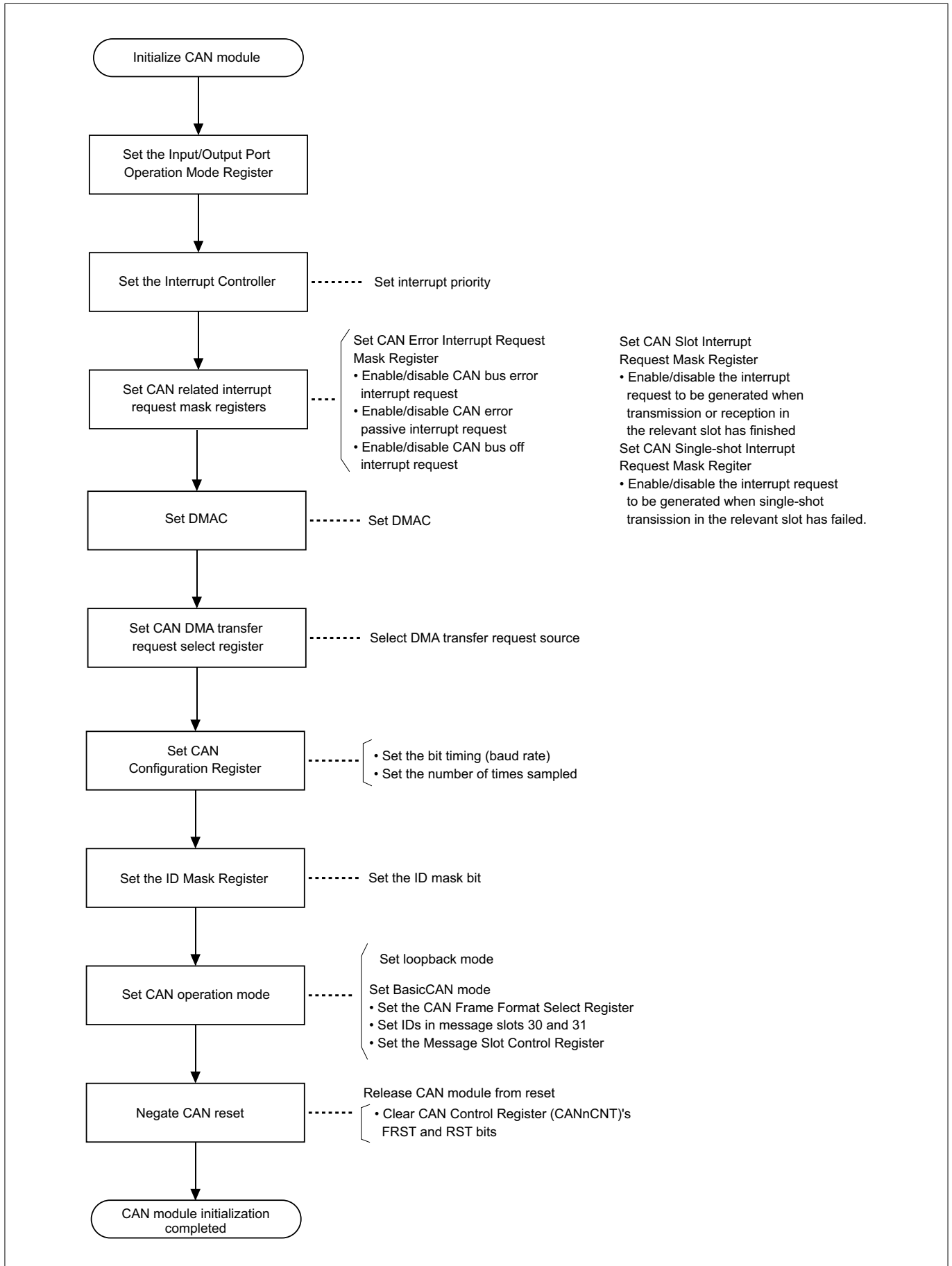
Using the CAN Mode Register (CAN0MODE, CAN1MODE) and CAN Control Register (CAN0CNT, CAN1CNT), select CAN module operation mode (BasicCAN, loopback mode) and the clock source for the timestamp counter.

## (11) Setting CAN module operation mode

In the CAN Single-Shot Mode Control Register, set the slot that is to be operated in single-shot mode.

## (12) Releasing CAN module from reset

When settings (1) through (11) above are finished, clear the CAN Control Register (CAN0CNT, CAN1CNT)'s forcible reset (FRST) and reset (RST) bits to "0." Then, after detecting 11 consecutive recessive bits on the CAN bus, the CAN module becomes ready to communicate.



**Figure 13.4.2 Initializing CAN Module**

## 13.5 Transmitting Data Frames

### 13.5.1 Data Frame Transmit Procedure

The following describes the procedure for transmitting data frames.

#### (1) Initializing CAN Message Slot Control Register

Initialize the CAN Message Slot Control Register for the slot to be transmitted by writing H'00 to the register.

#### (2) Confirming that transmission is idle

Read the CAN Message Slot Control Register that has been initialized and check the TRSTAT (Transmit/Receive Status) bit to see that transmission/reception has stopped and remains idle. If this bit = "1," it means that the CAN module is accessing the message slot. Therefore, wait until the bit is cleared to "0."

#### (3) Setting transmit data

Set the transmit ID and transmit data in the message slot.

#### (4) Setting CAN Frame Format Select Register

Set the corresponding bit in CAN Frame Format Select Register to "0" if the data is to be transmitted as a standard frame, or "1" if the data is to be transmitted as an extended frame.

#### (5) Setting CAN Message Slot Control Register

Write H'80 (Note 1) to the CAN Message Slot Control Register to set the TR (Transmit Request) bit to "1."

Note 1: Always be sure to write H'80 when transmitting data frames.

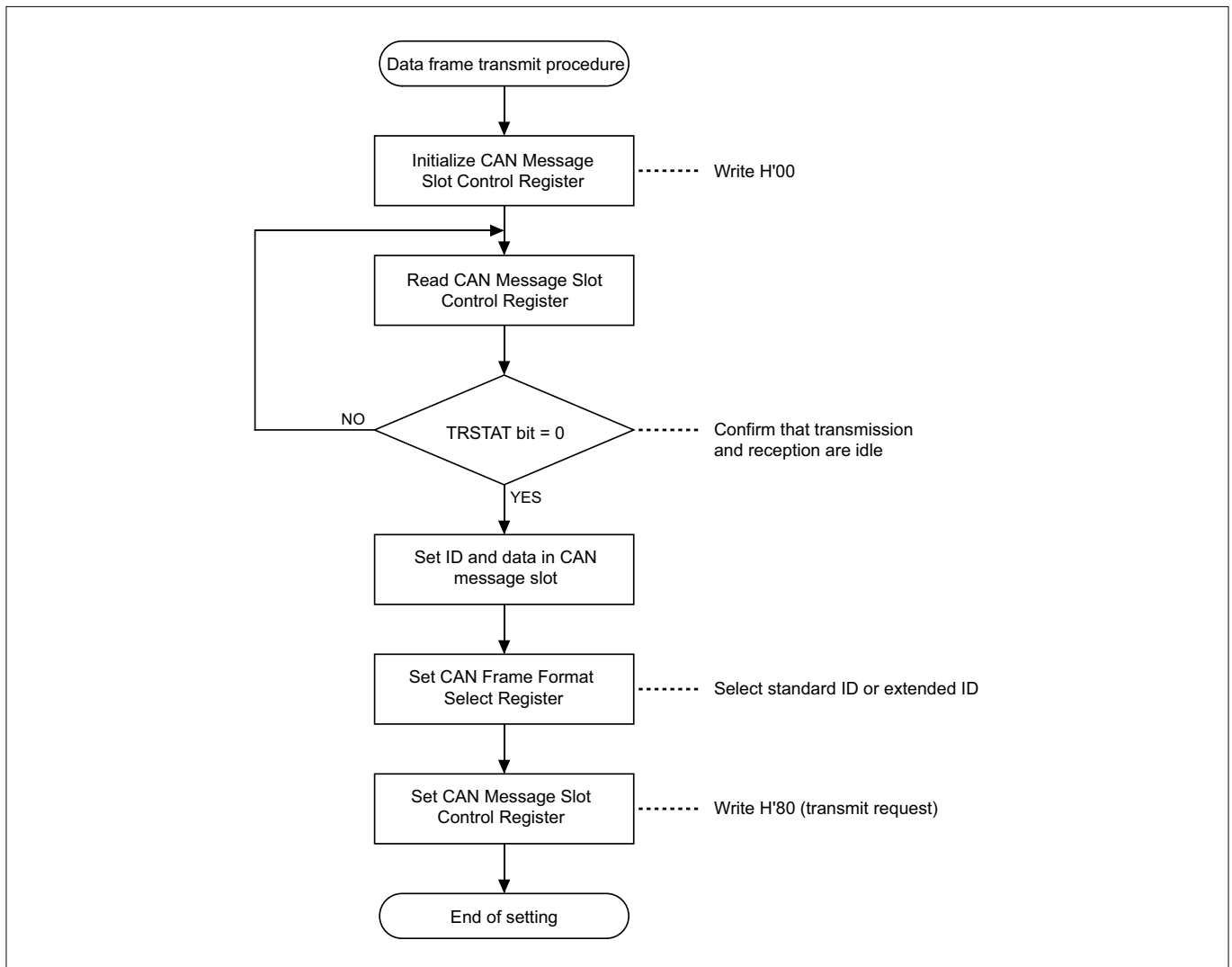


Figure 13.5.1 Data Frame Transmit Procedure

### 13.5.2 Data Frame Transmit Operation

The following describes data frame transmit operation. The operations described below are automatically performed in hardware.

#### (1) Selecting a transmit frame

The CAN module checks slots which have transmit requests (including remote frame transmit slots) every intermission to determine the frame to transmit. If two or more transmit slots exist, frames are transmitted in order of slot numbers beginning with the smallest.

#### (2) Transmitting a data frame

After determining the transmit slot, the CAN module sets the corresponding CAN Message Slot Control Register's TRSTAT (Transmit/Receive Status) bit to "1" and starts transmitting.

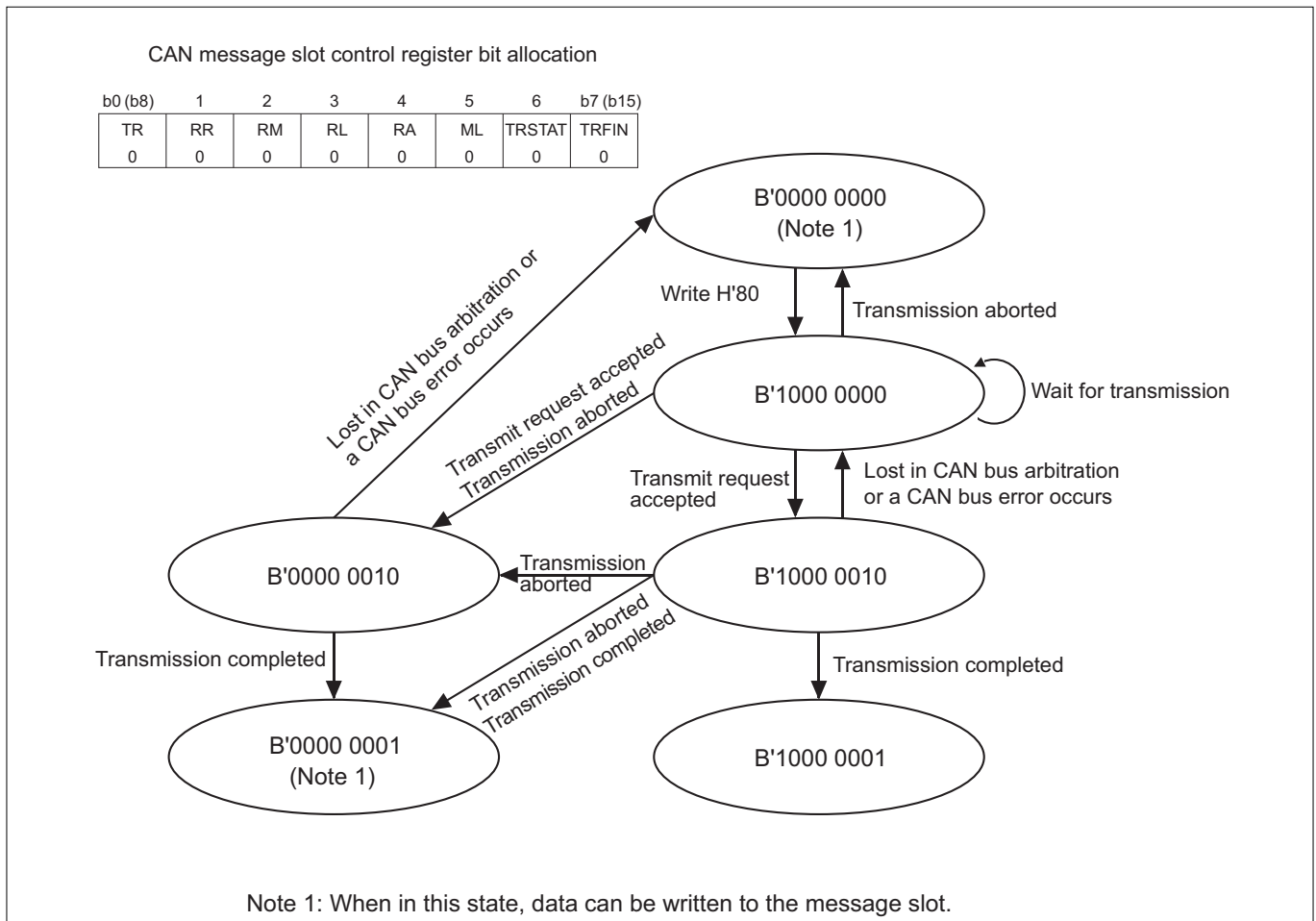
#### (3) If lost in CAN bus arbitration or a CAN bus error occurs

If the CAN module lost in CAN bus arbitration or a CAN bus error occurs in the middle of transmission, the CAN module clears the CAN Message Slot Control Register's TRSTAT (Transmit/Receive Status) bit to "0." If the CAN module requested a transmit abort, the transmit abort is accepted and the message slot is enabled for write.

**(4) Completion of data frame transmission**

When data frame transmission has finished, the CAN Message Slot Control Register's TRFIN (Transmit/Receive Finished) bit and the CAN Slot Interrupt Request Status Register are set to "1." Also, a timestamp count value at which transmission has finished is written to the CAN Message Slot Timestamp (C0MSLnTSP, C1MSLnTSP), and the transmit operation is thereby completed.

If the CAN slot interrupt request has been enabled, an interrupt request is generated at completion of transmit operation. The slot which has had transmission completed goes to an inactive state and remains inactive (neither transmit nor receive) until it is newly set in software.



**Figure 13.5.2 Operation of CAN Message Slot Control Register during Data Frame Transmission**

**13.5.3 Transmit Abort Function**

The transmit abort function is used to cancel a transmit request that has once been set. This is accomplished by writing H'0F to the CAN Message Slot Control Register for the slot to be canceled. When transmit abort is accepted, the CAN module clears the CAN Message Slot Control Register's TRSTAT (Transmit/Receive Status) bit to "0," allowing for data to be written to the message slot. The following shows the conditions under which transmit abort is accepted.

**[Conditions]**

- When the target message is waiting for transmission
- When a CAN bus error occurs during transmission
- When lost in CAN bus arbitration

## 13.6 Receiving Data Frames

### 13.6.1 Data Frame Receive Procedure

The following describes the procedure for receiving data frames.

#### (1) Initializing CAN Message Slot Control Register

Initialize the CAN Message Slot Control Register for the slot to be received by writing H'00 to the register.

#### (2) Confirming that reception is idle

Read the CAN Message Slot Control Register that has been initialized and check the TRSTAT (Transmit/Receive Status) bit to see that reception has stopped and remains idle. If this bit = "1," it means that the CAN module is accessing the message slot. Therefore, wait until the bit is cleared to "0."

#### (3) Setting the receive ID

Set the desired receive ID in the message slot.

#### (4) Setting CAN Frame Format Select Register

Set the corresponding bit in CAN Frame Format Select Register to "0" if a standard frame is to be received, or "1" if an extended frame is to be received.

#### (5) Setting CAN Message Slot Control Register

Write H'40 to the CAN Message Slot Control Register to set the RR (Receive Request) bit to "1."

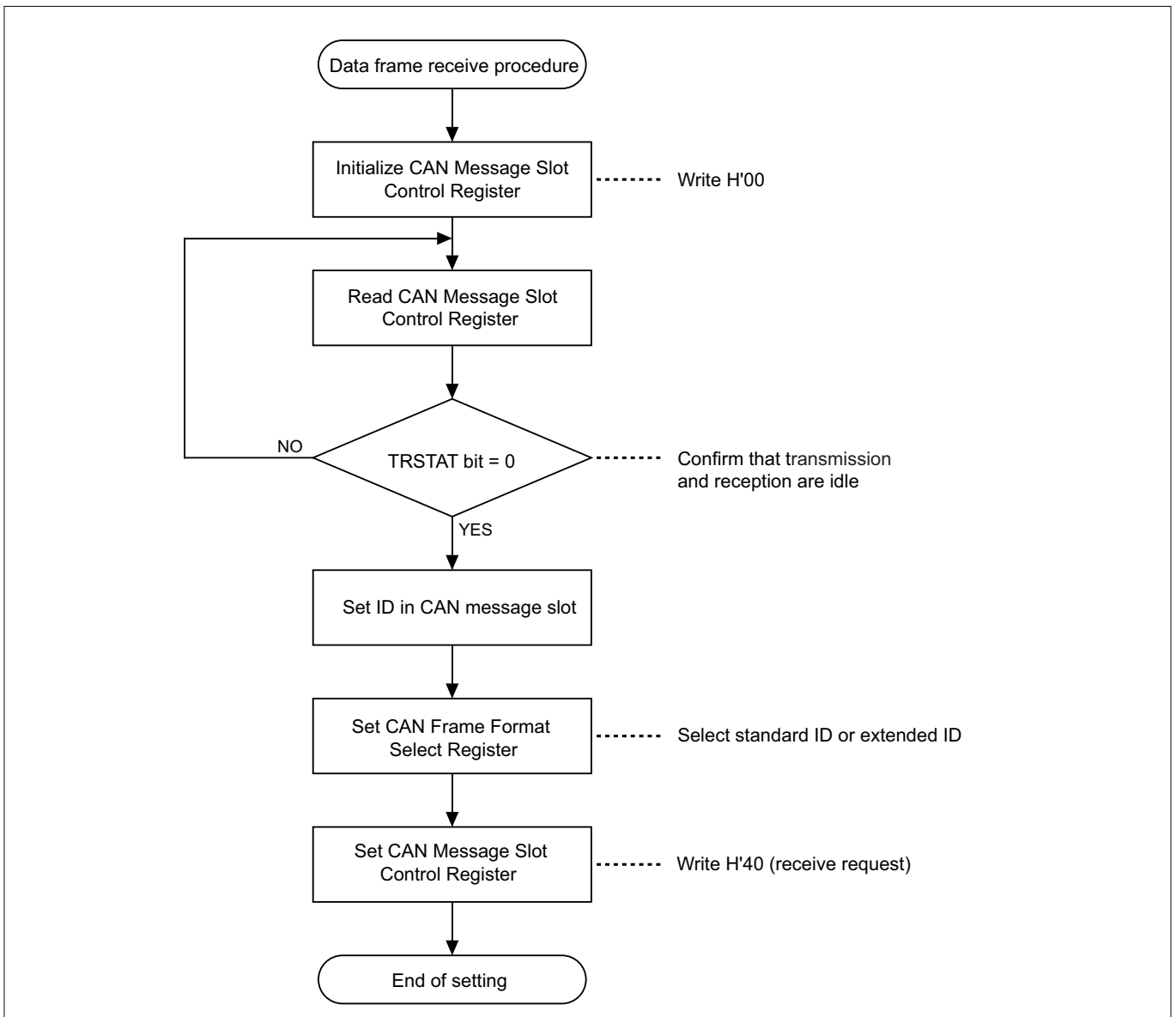


Figure 13.6.1 Data Frame Receive Procedure

### 13.6.2 Data Frame Receive Operation

The following describes data frame receive operation. The operations described below are automatically performed in hardware.

#### (1) Acceptance filtering

When the CAN module finished receiving data, it starts searching for the slot that satisfies the conditions for receiving the received message, sequentially from slot 0 (up to slot 31). The following shows receive conditions for the slots that have been set for data frame reception.

#### [Conditions]

- The received frame is a data frame.
- The receive ID and the slot ID are identical, assuming the ID Mask Register bits set to "0" are "Don't care."
- The standard and extended frame types are the same.

Note: • In BasicCAN mode, slots 30 and 31 while being set for data frame reception can also receive remote frames.



#### (2) When the receive conditions are met

When the receive conditions in (1) above are met, the CAN module sets the CAN Message Slot Control Register's TRSTAT (Transmit/Receive Status) bit and TRFIN (Transmit/Receive Finished) bit to "1" while at the same time writing the received data to the message slot. If the TRFIN (Transmit/Receive Finished) bit is already set to "1" at this time, the CAN module also sets the ML (Message Lost) bit to "1," indicating that the message slot has been overwritten. The message slot has both of its ID and DLC fields entirely overwritten and has an undefined value written in its unused area (e.g., extended ID field during standard frame reception and an unused data field).

Furthermore, a timestamp count value at which the message was received is written to the CAN Message Slot Timestamp (C0MSLnTSP, C1MSLnTSP) along with the received data. When the CAN module finished writing to the message slot, it sets the CAN Slot Interrupt Request Status bit to "1." If the interrupt request for the slot has been enabled, the CAN module generates an interrupt request and enters a wait state for the next reception.

#### (3) When the receive conditions are not met

The received frame is discarded, and the CAN module goes to the next transmit/receive operation without writing to the message slot.

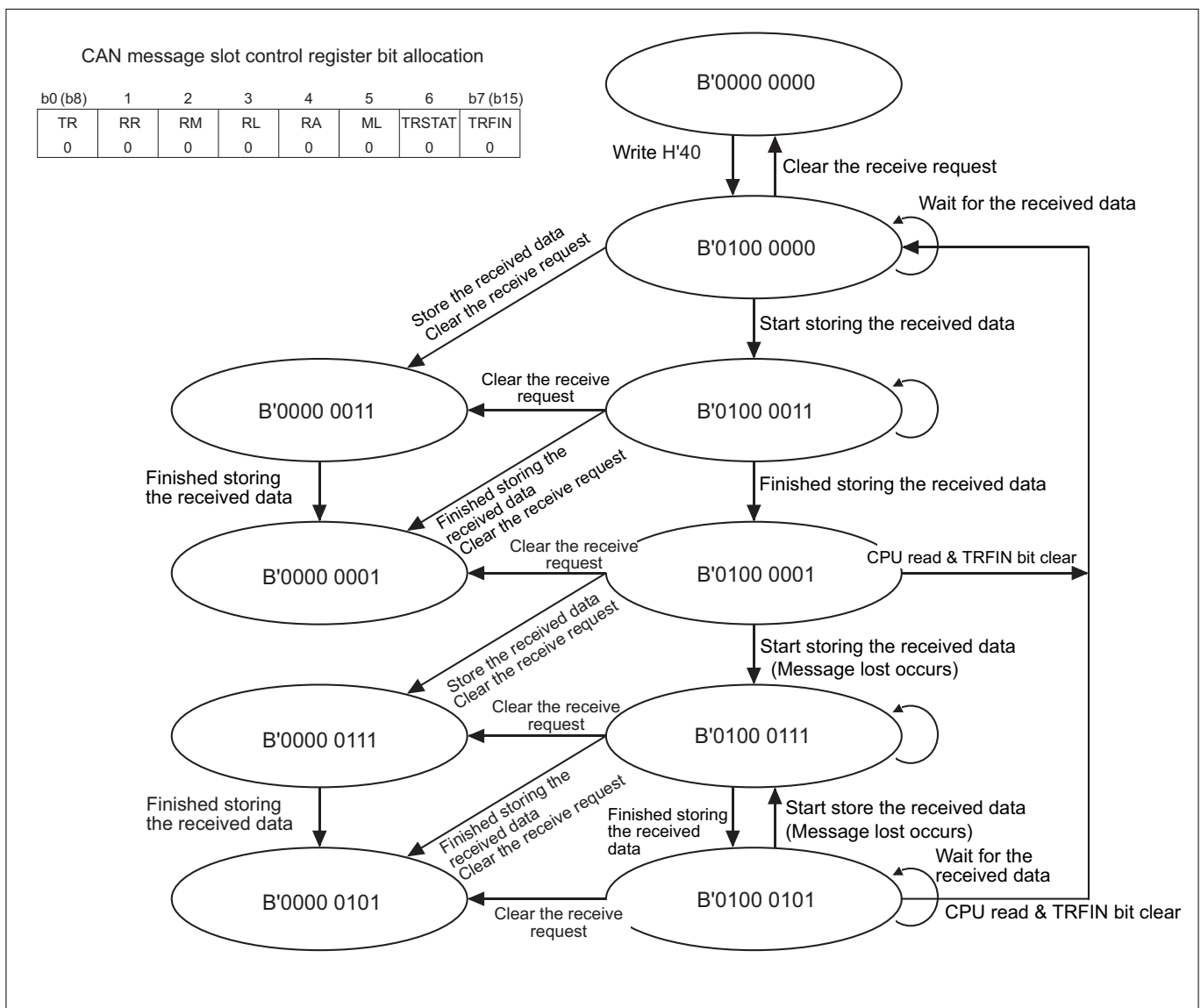


Figure 13.6.2 Operation of CAN Message Slot Control Register during Data Frame Reception

### 13.6.3 Reading Out Received Data Frames

The following shows the procedure for reading out received data frames from the slot.

#### (1) Clearing TRFIN (Transmit/Receive Finished) bit

Write H'4E, H'40 or H'00 to the CAN Message Slot Control Register (C0MSLnCNT, C1MSLnCNT) to clear the TRFIN bit to "0." After this write, the slot operates as follows:

Values Written to C0MSLnCNT, C1MSLnCNT	Slot Operation after Write
H'4E	Operates as a data frame receive slot. Whether overwritten can be verified by ML bit.
H'40	Operates as a data frame receive slot. Whether overwritten cannot be verified by ML bit.
H'00 (Note 1)	The slot stops transmit/receive operation.

Note 1: When the CAN Message Slot Control Register (C0MSLnCNT, C1MSLnCNT) RR (Receive Request) bit is cleared to "0" by writing H'00, if the receive operation has started until just before the bit is cleared, the transmit/receive control will be performed until the receive operation is finished.

Note : • If message-lost check by the ML bit is needed, write H'4E to clear the TRFIN bit.

#### (2) Reading out from the message slot

Read out a message from the message slot.

#### (3) Checking TRFIN (Transmit/Receive Finished) bit

Read the CAN Message Slot Control Register to check the TRFIN (Transmit/Receive Finished) bit.

##### 1) If TRFIN (Transmit/Receive Finished) bit = "1"

It means that new data was stored in the slot while still reading out a message from it in (2) above. In this case, the data read out in (2) may contain an undefined value. Therefore, reexecute the above procedure beginning with clearing of the TRFIN (Transmit/Receive Finished) bit in (1).

##### 2) If TRFIN (Transmit/Receive Finished) bit = "0"

It means that the CAN module finished reading out from the slot normally.

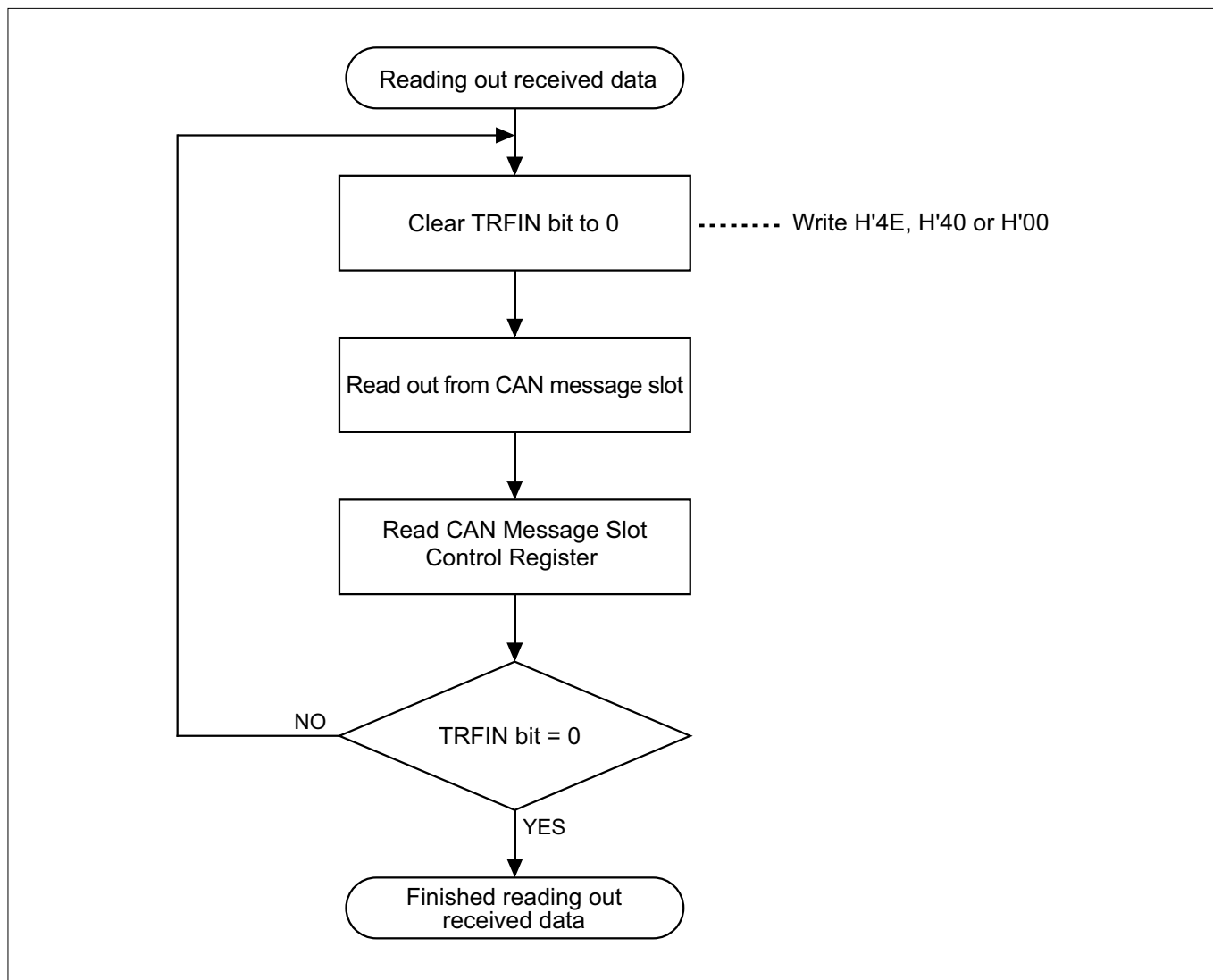


Figure 13.6.3 Procedure for Reading Out Received Data

## 13.7 Transmitting Remote Frames

### 13.7.1 Remote Frame Transmit Procedure

The following describes the procedure for transmitting remote frames.

#### (1) Initializing CAN Message Slot Control Register

Initialize the CAN Message Slot Control Register for the slot to be transmitted by writing H'00 to the register.

#### (2) Confirming that transmission is idle

Read the CAN Message Slot Control Register that has been initialized and check the TRSTAT (Transmit/Receive Status) bit to see that transmission/reception has stopped and remains idle. If this bit = "1," it means that the CAN module is accessing the message slot. Therefore, wait until the bit is cleared to "0."

#### (3) Setting transmit ID

Set the ID to be transmitted in the message slot.

#### (4) Setting CAN Frame Format Select Register

Set the corresponding bit in CAN Frame Format Select Register to "0" if the data is to be transmitted as a standard frame, or "1" if the data is to be transmitted as an extended frame.

#### (5) Setting CAN Message Slot Control Register

Write H'A0 to the CAN Message Slot Control Register to set the TR (Transmit Request) bit and RM (Remote) bit to "1."

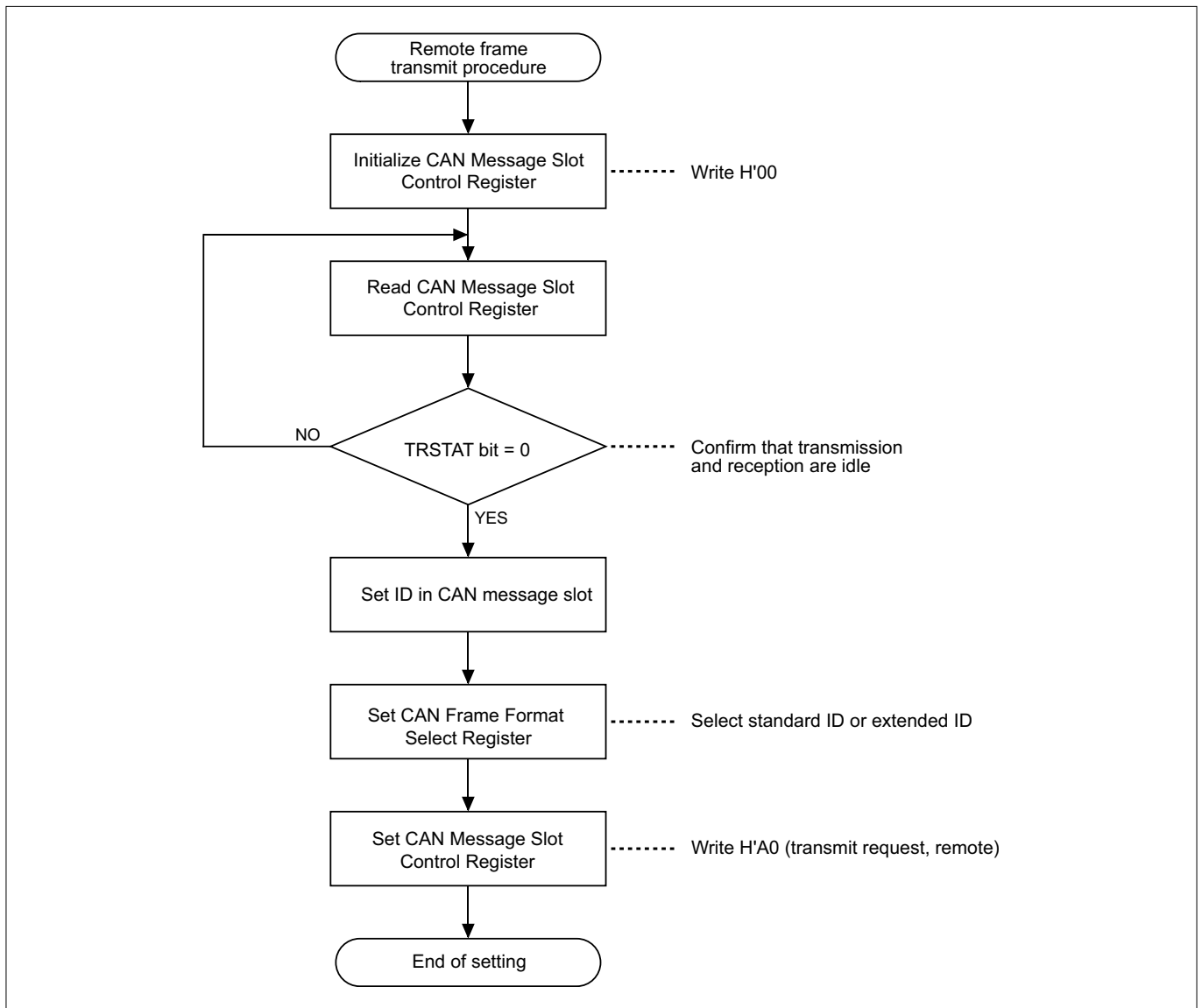


Figure 13.7.1 Remote Frame Transmit Procedure

### 13.7.2 Remote Frame Transmit Operation

The following describes remote frame transmit operation. The operations described below are automatically performed in hardware.

#### (1) Setting RA (Remote Active) bit

The RA (Remote Active) bit is set to "1" at the same time H'A0 (Transmit Request, Remote) is written to the CAN Message Slot Control Register, indicating that the corresponding slot is to handle remote frames.

#### (2) Selecting a transmit frame

The CAN module checks slots which have transmit requests (including data frame transmit slots) every intermission to determine the frame to transmit. If two or more transmit slots exist, frames are transmitted in order of slot numbers beginning with the smallest.

#### (3) Transmitting a remote frame

After determining the transmit slot, the CAN module sets the corresponding CAN Message Slot Control Register's TRSTAT (Transmit/Receive Status) bit to "1" and starts transmitting.

**(4) If lost in CAN bus arbitration or a CAN bus error occurs**

If the CAN module lost in CAN bus arbitration or a CAN bus error occurs in the middle of transmission, the CAN module clears the CAN Message Slot Control Register's TRSTAT (Transmit/Receive Status) bit to "0." If the CAN module requested a transmit abort, the transmit abort is accepted and the message slot is enabled for write.

**(5) Completion of remote frame transmission**

When remote frame transmission finishes, the timestamp count value at which transmission finished is written to the CAN Message Slot Timestamp (COMSLnTSP, C1MSLnTSP) and the CAN Message Slot Control Register's RA (Remote Active) bit is cleared to "0." In addition, the CAN Slot Interrupt Request Status bit is set to "1" by completion of transmission, but the CAN Message Slot Control Register's TRFIN (Transmit/Receive Finished) bit is not set to "1." If the CAN slot interrupt request has been enabled, an interrupt request is generated when transmission has finished.

**(6) Receiving a data frame**

When remote frame transmission finishes, the slot automatically starts functioning as a data frame receive slot.

**(7) Acceptance filtering**

When the CAN module finished receiving data, it starts searching for the slot that satisfies the conditions for receiving the received message, sequentially from slot 0 (up to slot 31). The following shows receive conditions for the slots that have been set for data frame reception.

**[Conditions]**

- The received frame is a data frame.
- The receive ID and the slot ID are identical, assuming the ID Mask Register bits set to "0" are "Don't care."
- The standard and extended frame types are the same.

Note: • In BasicCAN mode, slots 30 and 31 cannot be used as a transmit slot.

**(8) When the receive conditions are met**

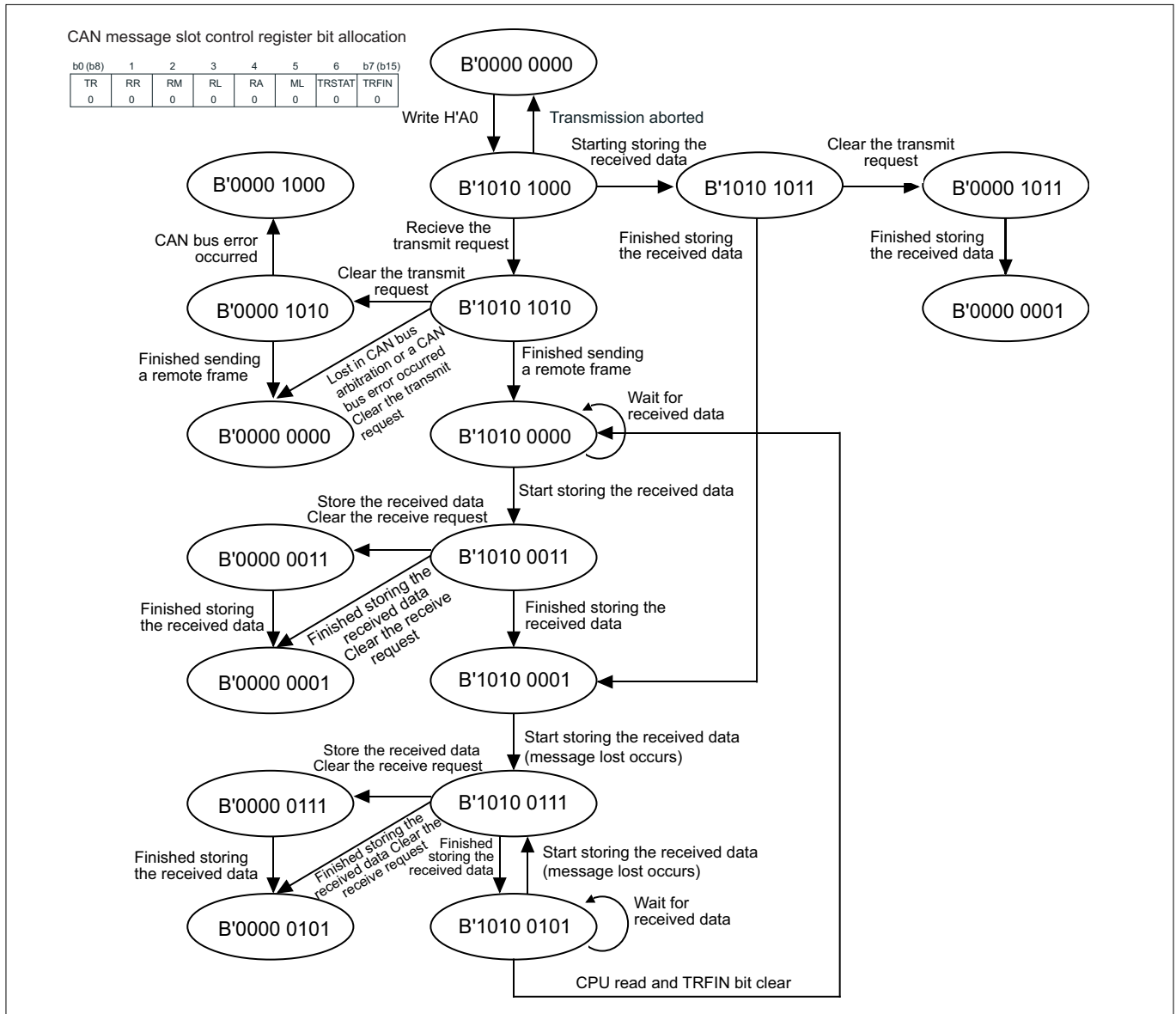
When the receive conditions in (7) above are met, the CAN module sets the CAN Message Slot Control Register's TRSTAT (Transmit/Receive Status) bit and TRFIN (Transmit/Receive Finished) bit to "1" while at the same time writing the received data to the message slot. If the TRFIN (Transmit/Receive Finished) bit is already set to "1" at this time, the CAN module also sets the ML (Message Lost) bit to "1," indicating that the message slot has been overwritten. The message slot has both of its ID and DLC fields entirely overwritten and has an undefined value written in its unused area (e.g., extended ID field during standard frame reception and an unused data field).

Furthermore, a timestamp count value at which the message was received is written to the CAN Message Slot Timestamp (COMSLnTSP, C1MSLnTSP) along with the received data. When the CAN module finished writing to the message slot, it sets the CAN Slot Interrupt Request Status bit to "1." If the interrupt request for the slot has been enabled, the CAN module generates an interrupt request and enters a wait state for the next reception.

Note: • If the CAN module receives a corresponding data frame before sending a remote frame, it stores the received data frame in the slot and does not transmit the remote frame.

**(9) When the receive conditions are not met**

The received frame is discarded, and the CAN module goes to the next transmit/receive operation without writing to the message slot.



**Figure 13.7.2 Operation of the CAN Message Slot Control Register during Remote Frame Transmission**

### 13.7.3 Reading Out Received Data Frames when Set for Remote Frame Transmission

The following shows the procedure for reading out the data frames that have been received in the slot when it is set for remote frame transmission.

#### (1) Clearing TRFIN (Transmit/Receive Finished) bit

Write H'AE or H'00 to the CAN Message Slot Control Register (C0MSLnCNT, C1MSLnCNT) to clear the TRFIN bit to "0." After this write, the slot operates as follows:

Values Written to C0MSLnCNT, C1MSLnCNT	Slot Operation after Write
H'AE	Operates as a data frame receive slot. Whether overwritten can be verified by ML bit.
H'00	The slot stops transmit/receive operation.

- Notes:
- If message-lost check by the ML bit is needed, write H'AE to clear the TRFIN bit.
  - If the TRFIN bit was cleared by writing H'AE or H'00, it is possible that new data will be stored in the slot while still reading out a message from it.
  - The received data frame cannot be read out by writing H'A0 to the register. If the TRFIN bit is cleared by writing H'A0, the slot performs remote frame transmit operation.

**(2) Reading out from the message slot**

Read out a message from the message slot.

**(3) Checking TRFIN (Transmit/Receive Finished) bit**

Read the CAN Message Slot Control Register to check the TRFIN (Transmit/Receive Finished) bit.

**1) If TRFIN (Transmit/Receive Finished) bit = "1"**

It means that new data was stored in the slot while still reading out a message from it in (2) above. In this case, the data read out in (2) may contain an undefined value. Therefore, reexecute the above procedure beginning with clearing of the TRFIN (Transmit/Receive Finished) bit in (1).

**2) If TRFIN (Transmit/Receive Finished) bit = "0"**

It means that the CAN module finished reading out from the slot normally.

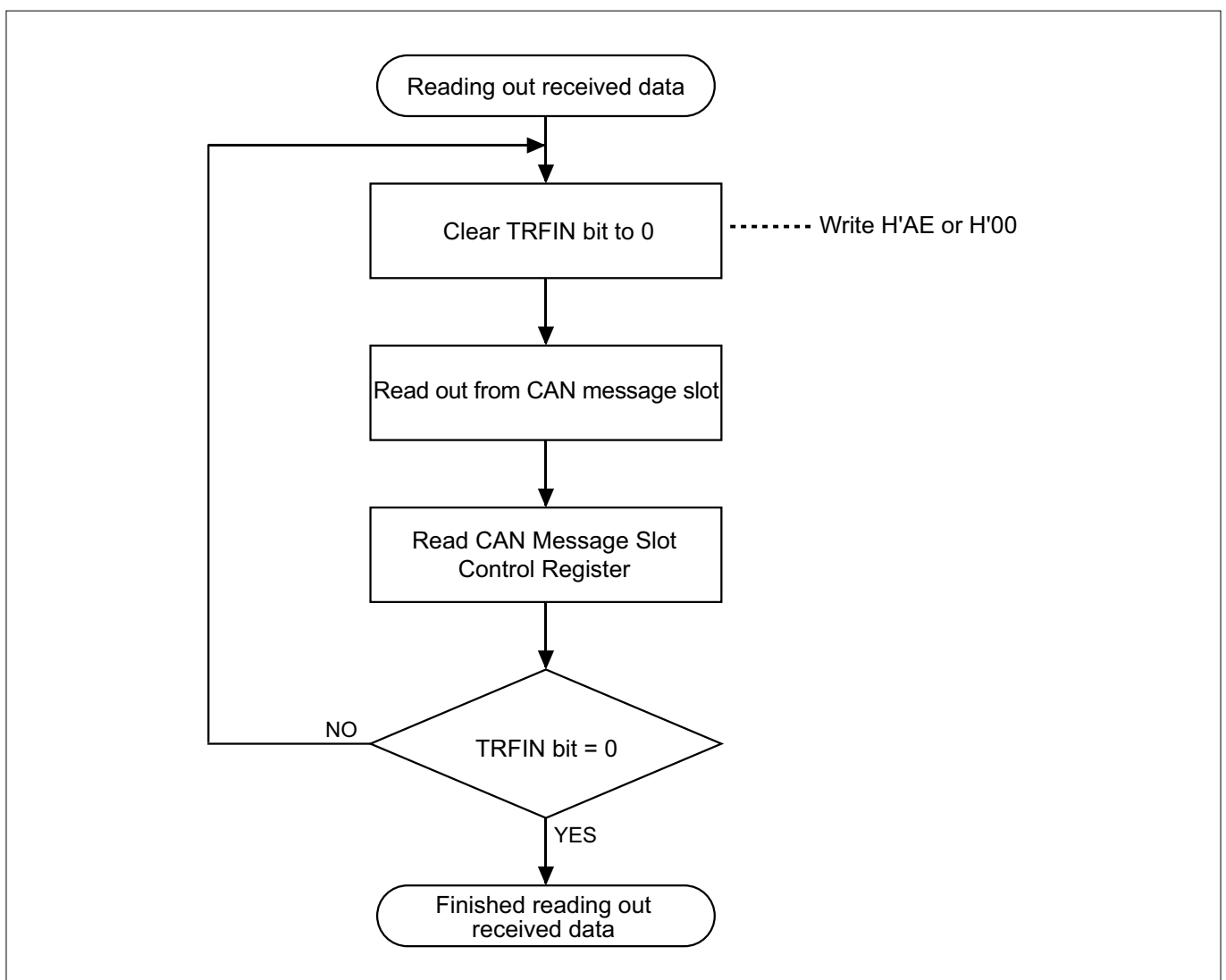


Figure 13.7.3 Procedure for Reading Out Received Data when Set for Remote Frame Transmission



## 13.8 Receiving Remote Frames

### 13.8.1 Remote Frame Receive Procedure

The following describes the procedure for receiving remote frames.

#### (1) Initializing CAN Message Slot Control Register

Initialize the CAN Message Slot Control Register for the slot to be received by writing H'00 to the register.

#### (2) Confirming that reception is idle

Read the CAN Message Slot Control Register that has been initialized and check the TRSTAT (Transmit/Receive Status) bit to see that reception has stopped and remains idle. If this bit = "1," it means that the CAN module is accessing the message slot. Therefore, wait until the bit is cleared to "0."

#### (3) Setting the receive ID

Set the desired receive ID in the message slot.

#### (4) Setting CAN Frame Format Select Register

Set the corresponding bit in CAN Frame Format Select to "0" if a standard frame is to be received, or "1" if an extended frame is to be received.

#### (5) Setting CAN Message Slot Control Register

##### 1) When automatic response (data frame transmission) for remote frame reception is desired

Write H'60 to the CAN Message Slot Control Register to set the RR (Receive Request) bit and RM (Remote) bit to "1."

##### 2) When automatic response (data frame transmission) for remote frame reception is to be disabled

Write H'70 to the CAN Message Slot Control Register to set the RR (Receive Request) bit, RM (Remote) bit and RL (Automatic Response Inhibit) bit to "1."

Note: • During BasicCAN mode, slots 30 and 31, although capable of receiving remote frames, cannot automatically respond to remote frame reception.

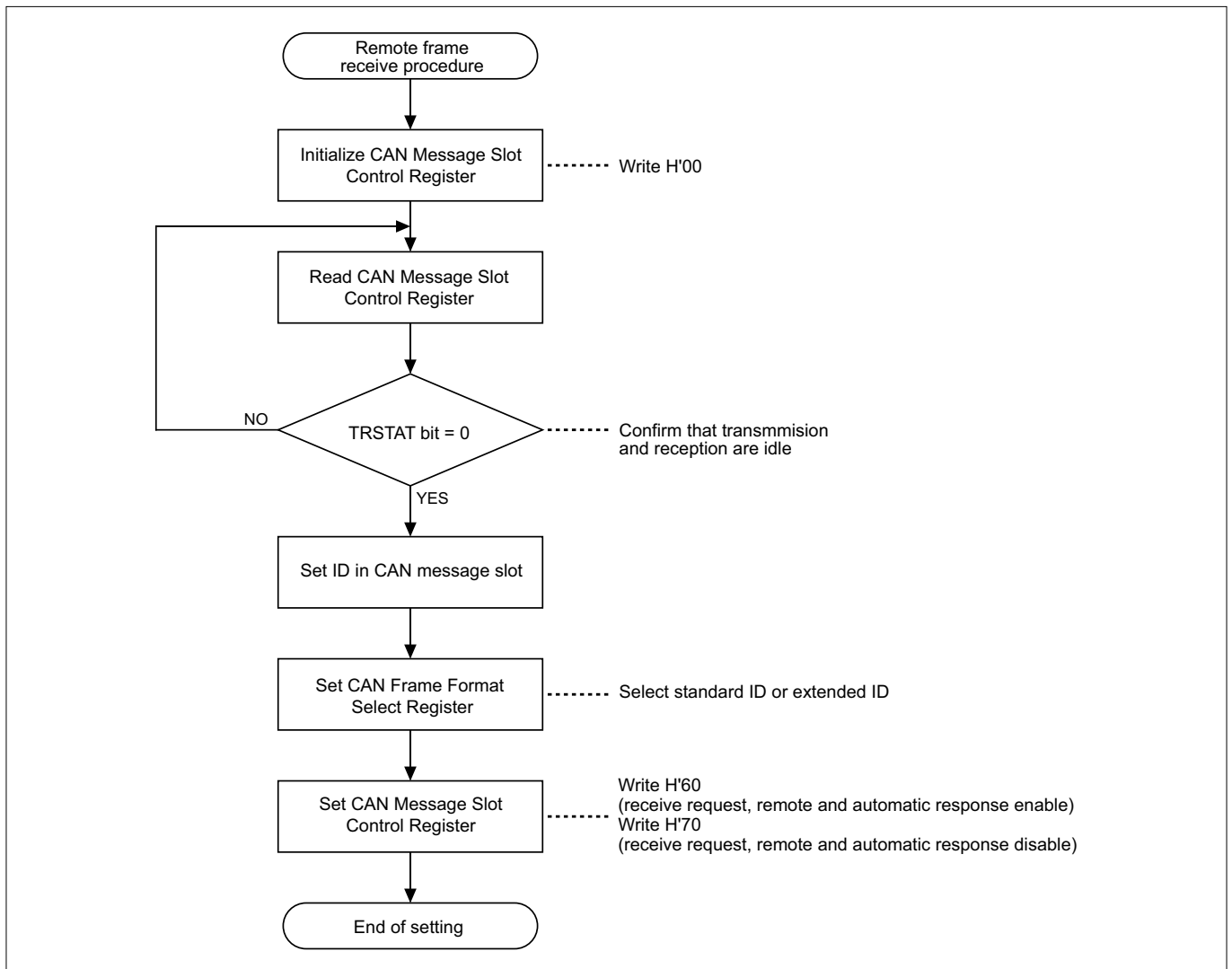


Figure 13.8.1 Remote Frame Receive Procedure

### 13.8.2 Remote Frame Receive Operation

The following describes remote frame receive operation. The operations described below are automatically performed in hardware.

#### (1) Setting RA (Remote Active) bit

The RA (Remote Active) bit indicating that the corresponding slot is to handle remote frames is set to "1" at the same time H'60 (Receive Request, Remote, Automatic Response Enable) or H'70 (Receive Request, Remote, Automatic Response Disable) is written to the CAN Message Slot Control Register.

#### (2) Acceptance filtering

When the CAN module finished receiving data, it starts searching for the slot that satisfies the conditions for receiving the received message, sequentially from slot 0 (up to slot 31). The following shows receive conditions for the slots that have been set for remote frame reception.

##### [Conditions]

- The received frame is a remote frame.
- The receive ID and the slot ID are identical, assuming the ID Mask Register bits set to "0" are "Don't care."
- The standard and extended frame types are the same.

**(3) When the receive conditions are met**

When the receive conditions in (2) above are met, the CAN module sets the CAN Message Slot Control Register's TRSTAT (Transmit/Receive Status) bit and TRFIN (Transmit/Receive Finished) bit to "1" while at the same time writing the received data to the message slot. In addition, a timestamp count value at which the message was received is written to the CAN Message Slot Timestamp (C0MSLnTSP, C1MSLnTSP) along with the received data. When the CAN module finished writing to the message slot, it sets the CAN Slot Interrupt Request Status bit to "1." If the interrupt request for the slot has been enabled, the CAN module generates an interrupt request.

Notes: • The ID field and DLC value are written to the message slot.

- An undefined value is written to the extended ID area when receiving standard format frames.
- The data field is not written to.
- The RA and TRFIN bits are cleared to "0" after writing the received remote frame data.

**(4) When the receive conditions are not met**

The received data is discarded, and the CAN module waits for the next receive frame. No data is written to the message slot.

**(5) Operation after receiving a remote frame**

The operation performed after receiving a remote frame differs depending on how automatic response is set.

**1) When automatic response is disabled**

The slot which has had reception completed goes to an inactive state and remains inactive (neither transmit nor receive) until it is newly set in software.

**2) When automatic response is enabled**

After receiving a remote frame, the slot automatically changes to a data frame transmit slot and performs the transmit operation described below. In this case, the transmitted data conforms to the ID and DLC of the received remote frame.

- **Selecting a transmit frame**

The CAN module checks slots which have transmit requests (including remote frame transmit slots) every intermission to determine the frame to transmit. If two or more transmit slots exist, frames are transmitted in order of slot numbers beginning with the smallest.

- **Transmitting a data frame**

After determining the transmit slot, the CAN module sets the corresponding CAN Message Slot Control Register's TRSTAT (Transmit/Receive Status) bit to "1" and starts transmitting.

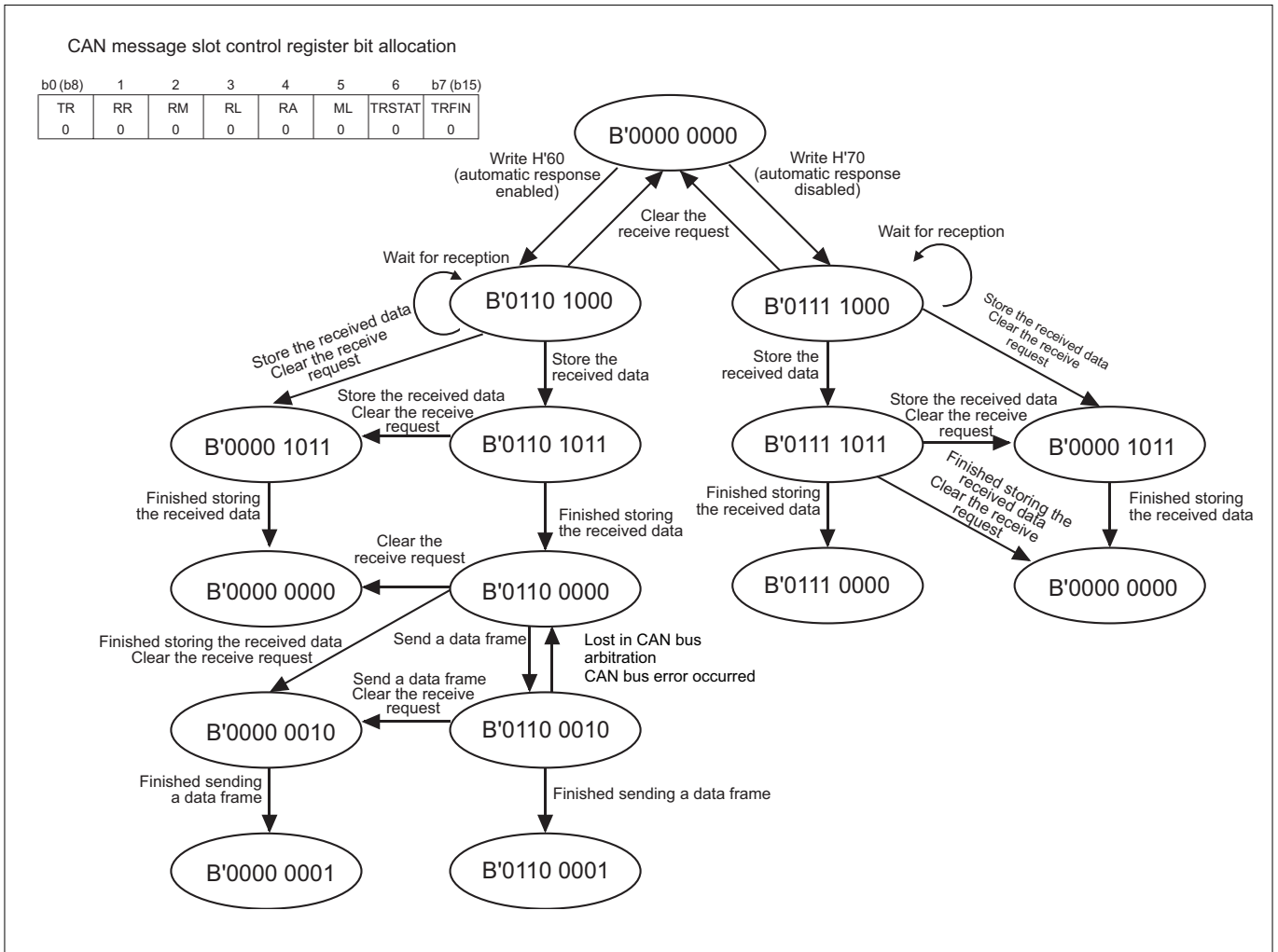
- **If lost in CAN bus arbitration or a CAN bus error occurs**

If the CAN module lost in CAN bus arbitration or a CAN bus error occurs in the middle of transmission, the CAN module clears the CAN Message Slot Control Register's TRSTAT (Transmit/Receive Status) bit to "0." If the CAN module requested a transmit abort, the transmit abort is accepted and the message slot is enabled for write.

- **Completion of data frame transmission**

When data frame transmission has finished, the CAN Message Slot Control Register's TRFIN (Transmit/Receive Finished) bit and the CAN Slot Interrupt Request Status Register are set to "1." Also, a timestamp count value at which transmission has finished is written to the CAN Message Slot Timestamp (C0MSLnTSP, C1MSLnTSP), and the transmit operation is thereby completed.

If the CAN slot interrupt request has been enabled, an interrupt request is generated at completion of transmit operation. The slot which has had transmission completed goes to an inactive state and remains inactive (neither transmit nor receive) until it is newly set in software.



**Figure 13.8.2 Operation of CAN Message Slot Control Register during Remote Frame Reception**

## 13.9 Notes on CAN Module

## • Note for cancelation of transmit and receive CAN remote frame

When aborting remote frame transmission or canceling remote frame receiving, make sure that the RA (Remote Active) bit is cleared to "0" after writing "H'00" or "H'0F" to the CAN Message Slot Control Register.

## (1) When aborting remote frame transmission

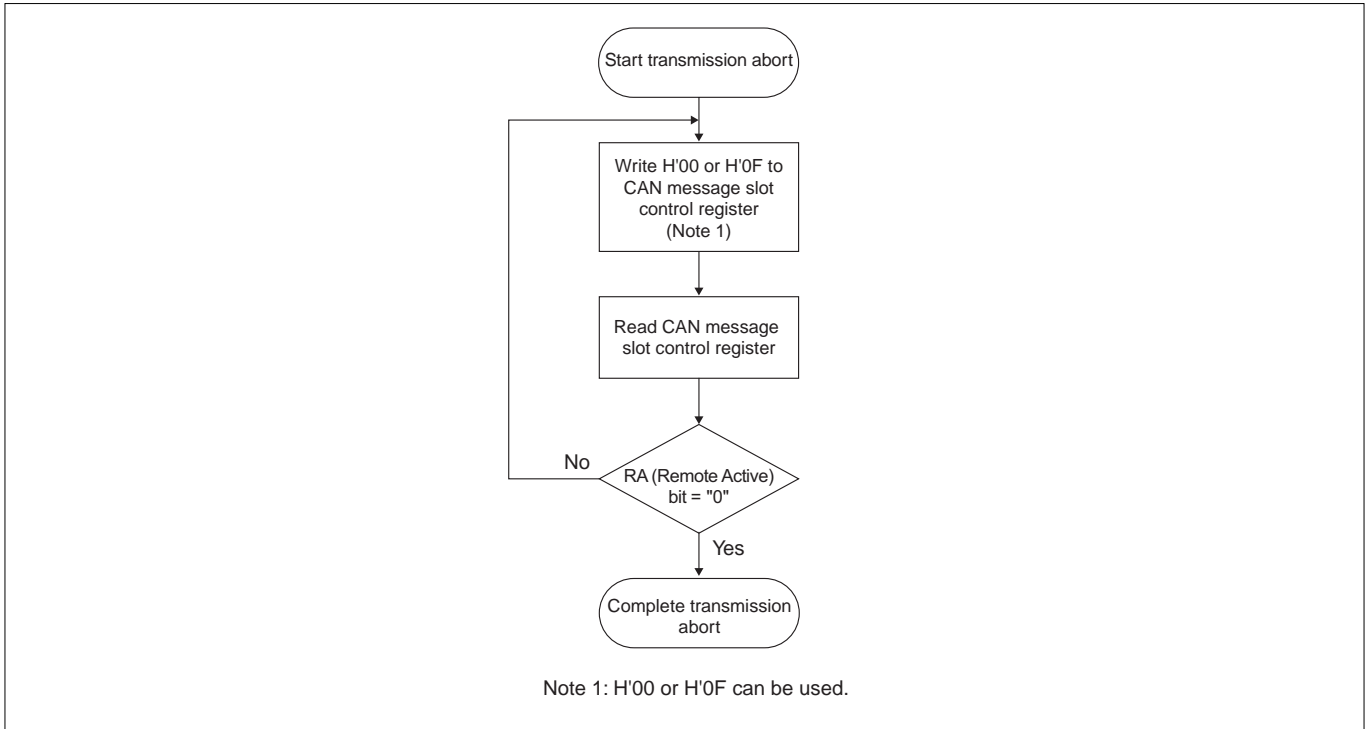


Figure 13.9.1 Operation Flow when Aborting Remote Frame Transmission

## (2) When canceling remote frame receiving

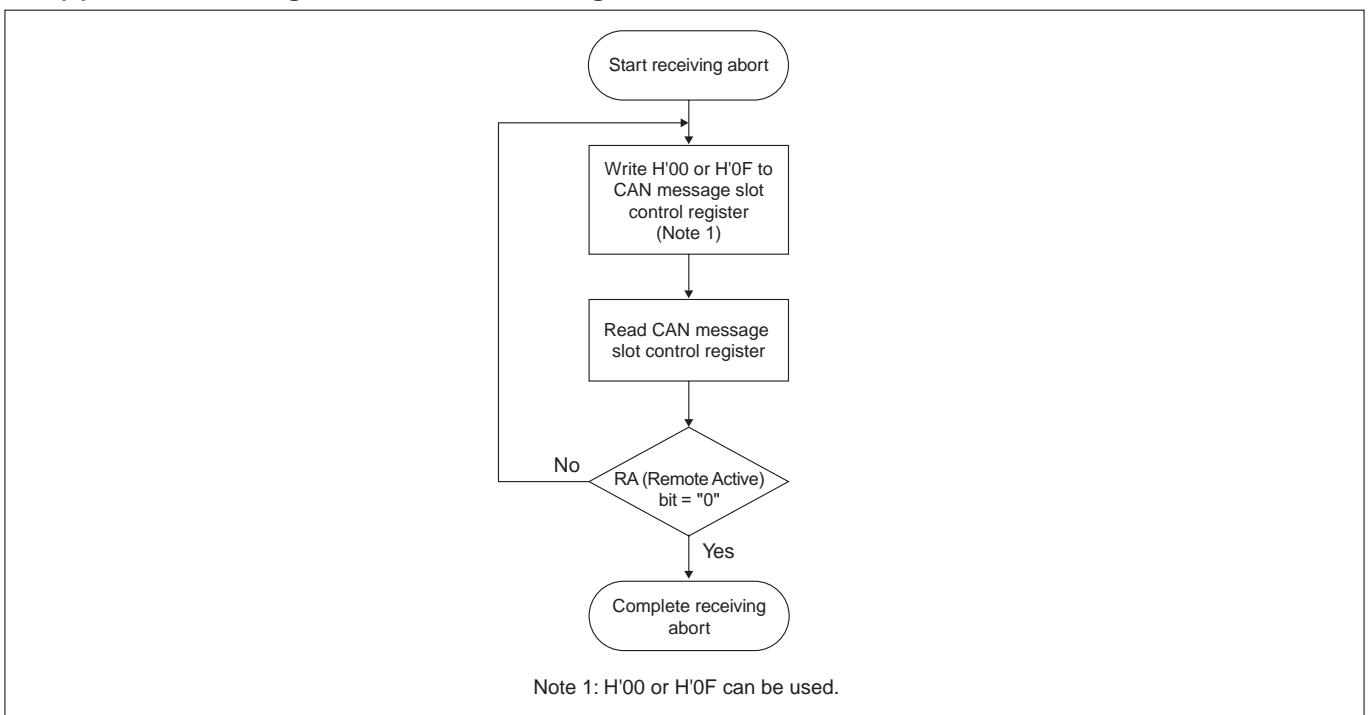


Figure 13.9.2 Operation Flow when Canceling Remote Frame Receiving

This page is blank for reasons of layout.

## **CHAPTER 14**

---

# **DIRECT RAM INTERFACE (DRI)**

- 14.1 Outline of the Direct RAM Interface (DRI)
- 14.2 DRI Related Registers
- 14.3 Notes on DRI

## 14.1 Outline of the Direct RAM Interface (DRI)

The Direct RAM Interface (DRI) is a parallel interface used to take in parallel data into the internal RAM as it is input to the microcomputer synchronously with the clock. Since a dedicated bus provided separately from the M32R-FPU is used to write data from the DRI to the internal RAM, data can be taken in without having to stop operation of the M32R-FPU. Furthermore, a selective data capture function is supported that makes use of the internal event counter of the DRI.

**Table 14.1.1 Outline of the Direct RAM Interface (DRI)**

Item	Function
Transfer method	Clock synchronous parallel input
RAM access area	Entire area of the internal RAM (32192: 176 Kbytes, 32195: 32 Kbytes, 32196: 64 Kbytes)
Received data width	Selectable from 32, 16 and 8 bits
Maximum transfer rate	40 Mbytes/sec
Minimum data capture cycle	100ns (when the special mode is not selected and input data bus width 32 bit), 87.5ns (when the special mode is not selected and input data bus width 16bit or 8bit), 50ns (when the special mode is not selected )
Data capture bus width	32/16/8 bits (when the special mode is not selected), 16/8 bits (when the special mode is selected)
Event counter	16 bits x 5 counters (DEC0–DEC4)
Bank switch function	Two banks in RAM specifiable as data storage destination
Data capture edge	Selectable from rising or falling edge or both edges
Capture timing adjust function	Timing from data capture edge detection to data sampling can be set
Selective data capture function	Data can be captured selectively using an internal event counter

Note: •  $f(\text{BCLK})=40\text{MHz}$  (during operation)

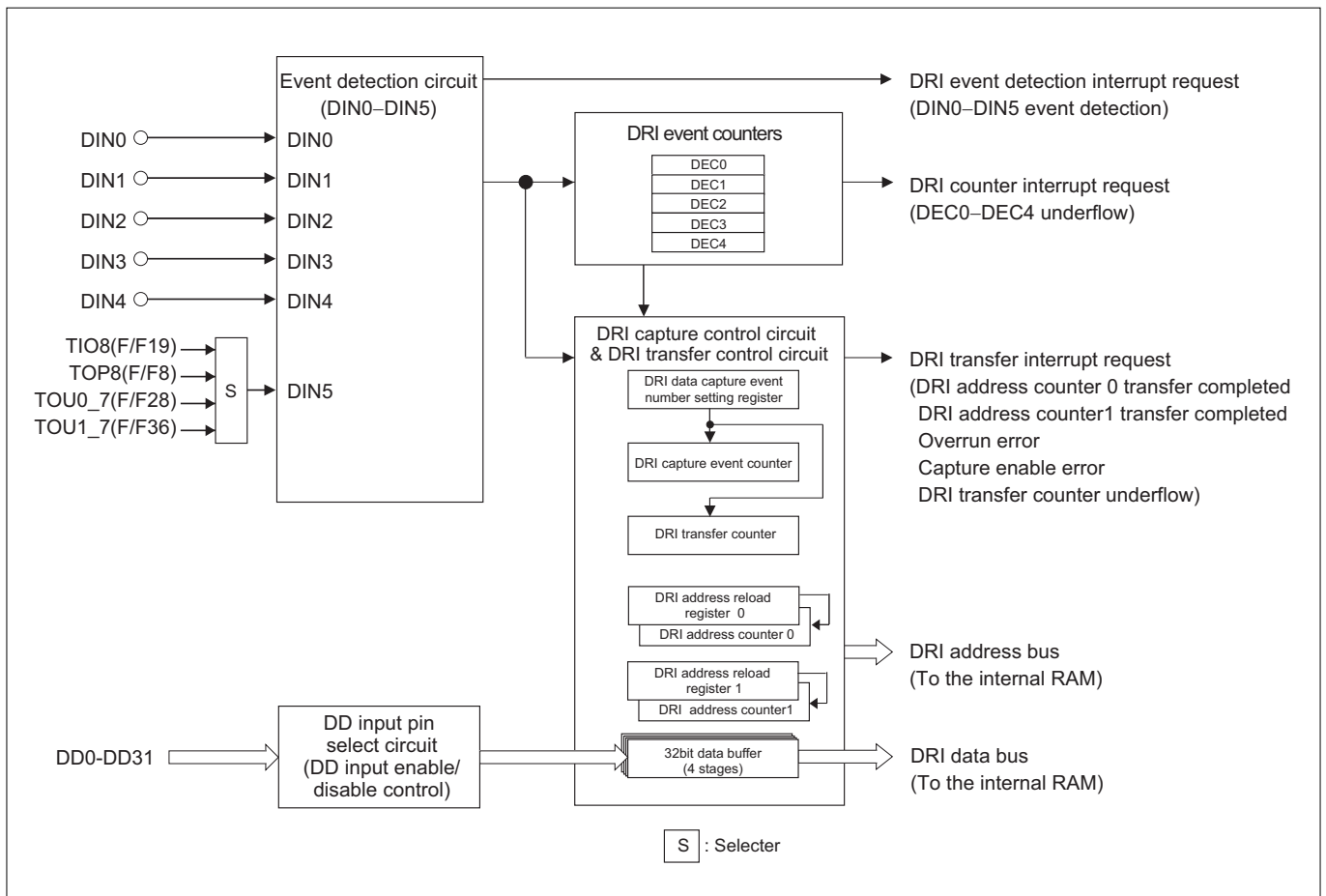
**Table 14.1.2 DRI Interrupt Request Generation Function**

DRI Interrupt Request	ICU Interrupt Source
DIN0 event detection	DRI event detection interrupt (group interrupt)
DIN1 event detection	
DIN2 event detection	
DIN3 event detection	
DIN4 event detection	
DIN5 event detection	
DEC0 underflow	DRI counter interrupt (group interrupt)
DEC1 underflow	
DEC2 underflow	
DEC3 underflow	
DEC4 underflow	
DRI address counter 0 transfer completed	DRI transfer interrupt (group interrupt)
DRI address counter 1 transfer completed	
Overrun error	
Capture enable error	
DRI transfer counter underflow	



**Table 14.1.3 DMA Transfer Request Generation Function of the DRI**

DMA Transfer Request of the DRI	DMAC Input Channel
DIN0 event detection	DMA0
DIN1 event detection	DMA1
DIN2 event detection	DMA2
DIN3 event detection	DMA3
DIN4 event detection	DMA4
DIN5 event detection	DMA9
DEC0 underflow	DMA5
DEC1 underflow	DMA6
DEC2 underflow	DMA7
DEC3 underflow	DMA8
DEC4 underflow	DMA9
DRI address counter 0 transfer completed	DMA6
DRI address counter 1 transfer completed	DMA7
DRI capture event counter underflow	DMA8
DRI transfer counter underflow	DMA9



**Figure 14.1.1 Block Diagram of the Direct RAM Interface (DRI)**

## 14.2 DRI Related Registers

The table below shows a DRI related register map.

DRI Related Register Map (1/2)

Address	+0 address b0	b7	+1 address b8	b15	See pages
H'0080 052A	DD Input Pin Select Register (DDSEL)				14-6
H'0080 2000	DIN Interrupt Request Status Register (DRIDINIST)		DIN Interrupt Request Enable Register (DRIDINIEN)		14-9
H'0080 2002	DEC Interrupt Request Status Register (DRIDECIST)		DEC Interrupt Request Enable Register (DRIDECIEN)		14-10
H'0080 2004	DRI Transfer Interrupt Request Status Register (DRITRMIST)		DRI Transfer Interrupt Request Enable Register (DRITRMIEN)		14-11 14-12
H'0080 2006	DRI Transfer Control Register (DRITRMCNT)		DRI Special Mode Register (DRISPMOD)		14-13 14-15
H'0080 2008	DRI Data Capture Control Register (DRIDCAPCNT)				14-18
H'0080 200A	DRI Data Interleave Control Register (DRIDSELCNT)		DIN Input Event Select Register (DINSEL)		14-22
H'0080 200C	DD Input Enable Register 0 (DRIDDEN0)		DD Input Enable Register 1 (DRIDDEN1)		14-23
H'0080 200E	DD Input Enable Register 2 (DRIDDEN2)		DD Input Enable Register 3 (DRIDDEN3)		14-23 14-24
H'0080 2010	DRI Data Capture Event Count Setting Register (Upper)				14-25
H'0080 2012	(Lower)				
H'0080 2014	DRI Capture Event Counter (Upper)				14-26
H'0080 2016	(Lower)				
H'0080 2018	DRI Transfer Counter (Upper)				14-27
H'0080 201A	(Lower)				
H'0080 201C	(Use inhibited area)				
H'0080 201E	(Use inhibited area)				
H'0080 2020	DRI Address Reload Register 0 (Upper)				14-29
H'0080 2022	(Lower)				
H'0080 2024	DRI Address Counter 0 (Upper)				14-28
H'0080 2026	(Lower)				
H'0080 2028	DRI Address Reload Register 1 (Upper)				14-29
H'0080 202A	(Lower)				
H'0080 202C	DRI Address Counter 1 (Upper)				14-28
H'0080 202E	(Lower)				
H'0080 2030	DIN Input Processing Control Register (DINCNT)				14-30
H'0080 2032	DEC0 Control Register (DEC0CNT)		(Use inhibited area)		14-31
H'0080 2034	DEC0 Reload Register (DEC0RLD)				14-36
H'0080 2036	DEC0 Counter (DEC0CT)				14-36
H'0080 2038	DEC1 Control Register (DEC1CNT)		(Use inhibited area)		14-31
H'0080 203A	DEC1 Reload Register (DEC1RLD)				14-36

## DRI Related Register Map (2/2)

Address	+0 address		+1 address		See pages
	b0	b7	b8	b15	
H'0080 203C	DEC1 Counter (DEC1CT)				14-36
H'0080 203E	DEC2 Control Register (DEC2CNT)		(Use inhibited area)		14-32
H'0080 2040	DEC2 Reload Register (DEC2RLD)				14-36
H'0080 2042	DEC2 Counter (DEC2CT)				14-36
H'0080 2044	DEC3 Control Register (DEC3CNT)		(Use inhibited area)		14-32
H'0080 2046	DEC3 Reload Register (DEC3RLD)				14-36
H'0080 2048	DEC3 Counter (DEC3CT)				14-36
H'0080 204A	DEC4 Control Register (DEC4CNT)		(Use inhibited area)		14-33
H'0080 204C	DEC4 Reload Register (DEC4RLD)				14-36
H'0080 204E	DEC4 Counter (DEC4CT)				14-36

### 14.2.1 DD Input Pin Select Register

DD Input Pin Select Register (DDSEL)

&lt;Address: H'0080 052B&gt;

b8	9	10	11	12	13	14	b15
0	0	0	0	0	0	0	DD03SEL 0

&lt;Upon exiting reset: H'00&gt;

b	Bit Name	Function	R	W
8–14	No function assigned. Fix to "0."		0	0
15	DD03SEL DD0–3 input pin select bit	0: DD0 → P127/TCLK3/CS3#/DD0 DD1 → P126/TCLK2/CS2#/DD1 DD2 → P125/TCLK1/A10/DD2 DD3 → P124/TCLK0/A9/DD3 1: DD0 → P107/TO15/RXD4/DD0 DD1 → P106/TO14/TXD4/DD1 DD2 → P105/TO13/SCLKI4/SCLKO4/DD2 DD3 → P104/TO12/TIN25/DD3	R	W

#### (1) DD03SEL(DD0–3 Input Pin Select) bit (Bit 15)

About 16 high-order bits of DDn(n= 0 to 31)which is data input to DRI, pins can be selected from two groups (pin groups A or B). Which pin groups (pin groups A or B) is used is selected in the DDSL (DD input 16 high-order bit pin select) bit of DRI Data Capture Control Register (DRIDCAPCNT).In this DDSEL register, it selects which pin is used for DD0 to DD3 when pin group A is selected.

In the DDSL bit of DRIDCAPCNT register when pin group B is selected, setting of this DDSEL register is ignored.

In order to use pin function as DD input pin, port operation mode register also needs to be set up separately. Pin group table is shown in Table 14.2.2.

### 14.2.2 DRI Interrupt Related Registers

The DRI interrupt related registers are used to control the interrupt request signals output to the Interrupt Controller from the DRI.

#### (1) Interrupt request status bit

This status bit is used to determine whether an interrupt is requested. When an interrupt request occurs, this bit is set in hardware (cannot be set in software). The status bit is cleared by writing "0." Writing "1" has no effect; the bit retains the status it had before the write. Because this bit is unaffected by the interrupt request enable bit, it can also be used to inspect the operating status of peripheral functions. In interrupt handling, make sure that within the grouped interrupt request status, only the status bit for the interrupt request that has been serviced is cleared. If the status bit for any interrupt request that has not been serviced is cleared, the pending interrupt request is cleared simultaneously with its status bit.

#### (2) Interrupt request enable bit

This bit is used to disable unnecessary interrupt requests within the grouped interrupt request. Set this bit to "1" to enable interrupt requests or "0" to disable interrupt requests.

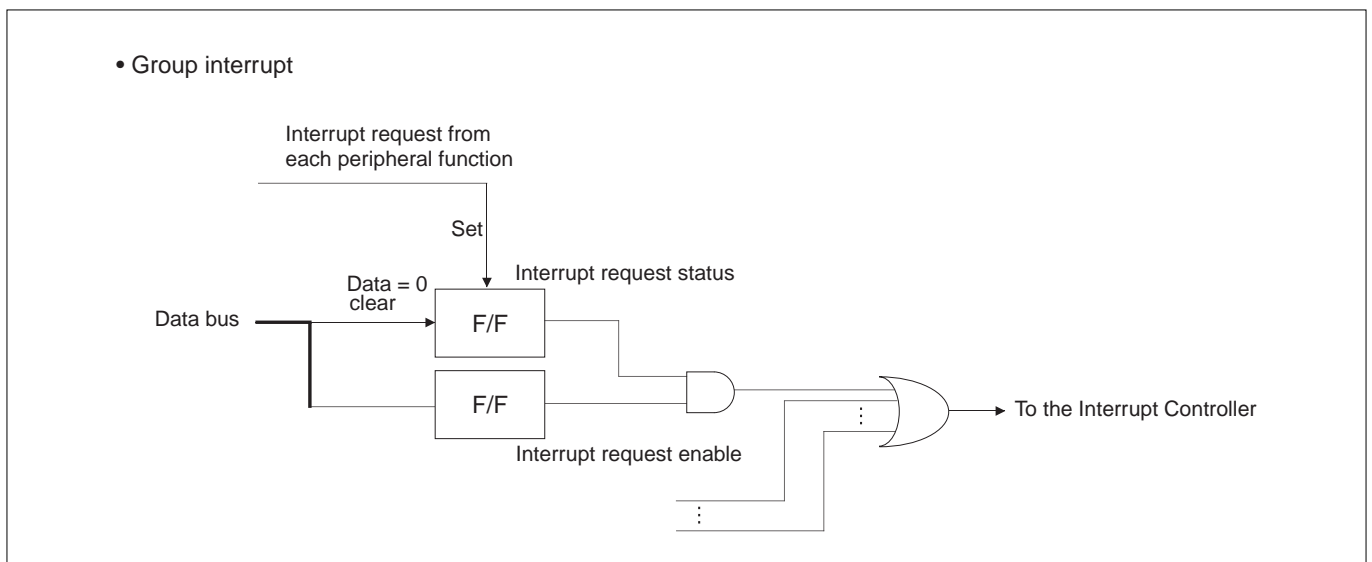
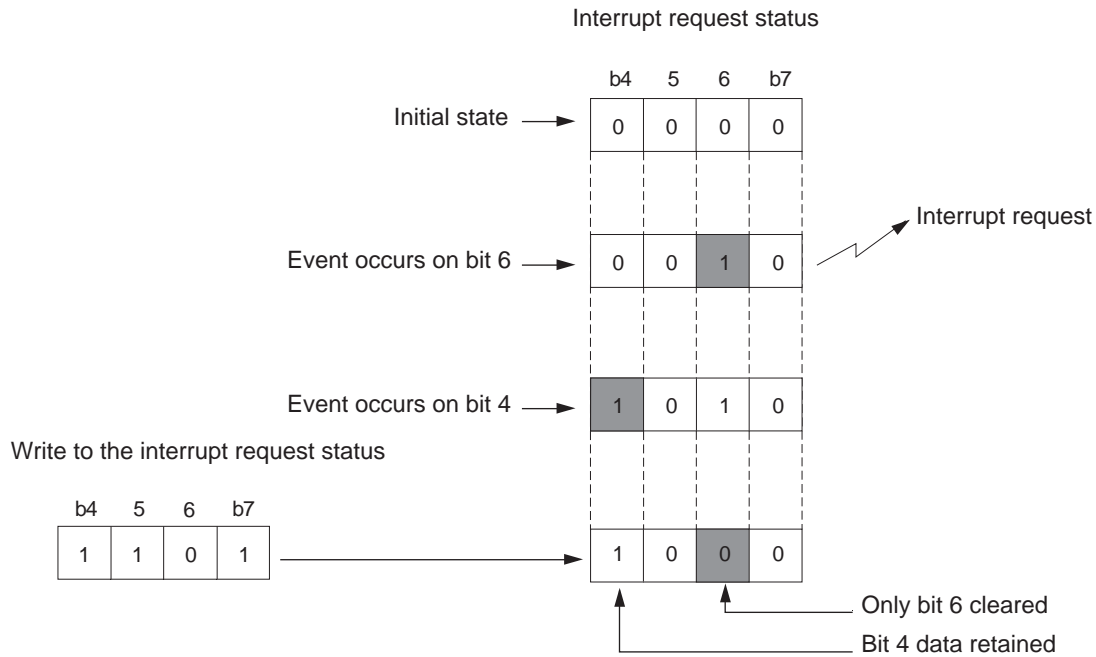


Figure 14.2.1 Interrupt Request Status and Mask Registers

● Example for clearing interrupt request status



● Program example

- To clear the Interrupt Request Status Register 0 (ISTREG) interrupt request status 1, ISTAT1 (0x02 bit)

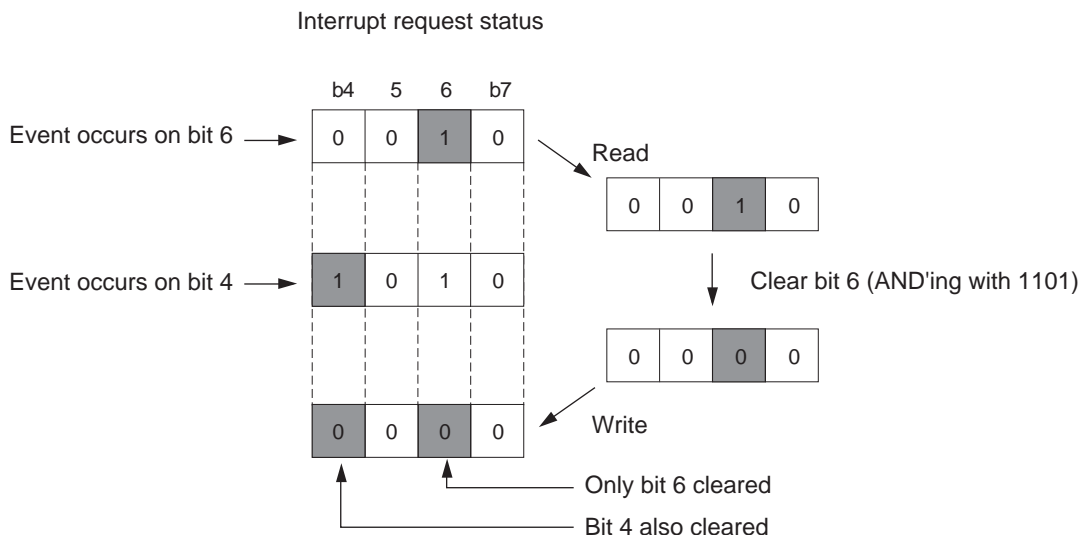


```
ISTREG = 0xfd; /* Clear ISTAT1 (0x02 bit) only */
```

To clear an interrupt request status, always be sure to write 1 to all other interrupt request status bits. At this time, avoid using a logic operation like the one shown below. Because it requires three step-ISTREG read, logic operation and write, if another interrupt request occurs between the read and write, status may be inadvertently cleared.



```
ISTREG &= 0xfd; /* Clear ISTAT1 (0x02 bit) only */
```



**Figure 14.2.2 Example for Clearing Interrupt Request Status**

## DIN Interrupt Request Status Register (DRIDINIST)

&lt;Address: H'0080 2000&gt;

b0	1	2	3	4	5	6	b7
DIN0IS	DIN1IS	DIN2IS	DIN3IS	DIN4IS	DIN5IS		
0	0	0	0	0	0	0	0

&lt;Upon exiting reset: H'00&gt;

b	Bit Name	Function	R	W
0	DIN0IS DIN0 interrupt request status bit	0: Interrupt not requested 1: Interrupt requested		R(Note 1)
1	DIN1IS DIN1 interrupt request status bit			
2	DIN2IS DIN2 interrupt request status bit			
3	DIN3IS DIN3 interrupt request status bit			
4	DIN4IS DIN4 interrupt request status bit			
5	DIN5IS DIN5 interrupt request status bit			
6, 7	No function assigned. Fix to "0."		0	0

Note 1: Only writing "0" is effective. Writing "1" has no effect, so that the bit retains the previous value.

If a DINn event is detected according to settings of the DIN Input Processing Control Register, the status bit corresponding to that DINn is set to "1" in hardware.

Note: • If the status is cleared in software at the same time it is set for an interrupt request generated, the latter has priority, so that the status is set.

## DIN Interrupt Request Enable Register (DRIDINIEN)

&lt;Address: H'0080 2001&gt;

b8	9	10	11	12	13	14	b15
DIN0IEN	DIN1IEN	DIN2IEN	DIN3IEN	DIN4IEN	DIN5IEN		
0	0	0	0	0	0	0	0

&lt;Upon exiting reset: H'00&gt;

b	Bit Name	Function	R	W
8	DIN0IEN (DIN0 interrupt request enable bit)	0: Mask (disable) interrupt request	R	W
9	DIN1IEN (DIN1 interrupt request enable bit)	1: Enable interrupt request		
10	DIN2IEN (DIN2 interrupt request enable bit)			
11	DIN3IEN (DIN3 interrupt request enable bit)			
12	DIN4IEN (DIN4 interrupt request enable bit)			
13	DIN5IEN (DIN5 interrupt request enable bit)			
14, 15	No function assigned. Fix to "0."		0	0

This register disables or enables the interrupt requests that will be generated for DINn event detection. Setting any bit in this register to "1" enables the corresponding DINn event detection interrupt request.

DEC Interrupt Request Status Register (DRIDECIST)

&lt;Address: H'0080 2002&gt;

b0	1	2	3	4	5	6	b7
DEC0IS	DEC1IS	DEC2IS	DEC3IS	DEC4IS			
0	0	0	0	0	0	0	0

&lt;Upon exiting reset: H'00&gt;

b	Bit Name	Function	R	W
0	DEC0IS (DEC0 interrupt request status bit)	0: Interrupt not requested	R	Note 1)
1	DEC1IS (DEC1 interrupt request status bit)	1: Interrupt requested		
2	DEC2IS (DEC2 interrupt request status bit)			
3	DEC3IS (DEC3 interrupt request status bit)			
4	DEC4IS (DEC4 interrupt request status bit)			
5–7	No function assigned. Fix to "0."		0	0

Note 1: Only writing "0" is effective. Writing "1" has no effect, so that the bit retains the previous value.

If one of five event counters (DEC0–DEC4) included in the DRI underflows upon reaching the terminal count, the corresponding status bit in this register is set to "1" in hardware.

Note: • If the status is cleared in software at the same time it is set for an interrupt request generated, the latter has priority, so that the status is set.

DEC Interrupt Request Enable Register (DRIDECIEN)

&lt;Address: H'0080 2003&gt;

b8	9	10	11	12	13	14	b15
DEC0IEN	DEC1IEN	DEC2IEN	DEC3IEN	DEC4IEN			
0	0	0	0	0	0	0	0

&lt;Upon exiting reset: H'00&gt;

b	Bit Name	Function	R	W
8	DEC0IEN (DEC0 interrupt request enable bit)	0: Mask (disable) interrupt request	R	W
9	DEC1IEN (DEC1 interrupt request enable bit)	1: Enable interrupt request		
10	DEC2IEN (DEC2 interrupt request enable bit)			
11	DEC3IEN (DEC3 interrupt request enable bit)			
12	DEC4IEN (DEC4 interrupt request enable bit)			
13–15	No function assigned. Fix to "0."		0	0

This register enables or disables the interrupt requests that will be generated when one of the internal event counters underflows.

Setting any bit in this register to "1" enables the interrupt request by the corresponding event counter underflow.



DRI Transfer Interrupt Request Status Register (DRITRMIST)

&lt;Address: H'0080 2004&gt;

b0	1	2	3	4	5	6	b7
ADR0IS	ADR1IS	OVREIS	DCPEIS	DTRFIS			
0	0	0	0	0	0	0	0

&lt;Upon exiting reset: H'00&gt;

b	Bit Name	Function	R	W
0	ADR0IS DRI address counter 0 interrupt request status bit	0: Interrupt not requested 1: Interrupt requested	R(Note 1)	
1	ADR1IS DRI address counter 1 interrupt request status bit			
2	OVREIS Overrun error interrupt request status bit			
3	DCPEIS Capture enable error interrupt request status bit			
4	DTRFIS DRI transfer counter interrupt request status bit			
5-7	No function assigned. Fix to "0."		0	0

Note 1: Only writing "0" is effective. Writing "1" has no effect, so that the bit retains the previous value.

**(1) ADR0IS (DRI Address Counter 0 Interrupt Request Status) bit (Bit 0)**

If while DRI address counter 0 (DRIADR0CT) is enabled as the destination of transfer for the captured data the DRI transfer counter (DRITRMCT) underflows (H'0000 0000: count stop) upon reaching the terminal count, this bit is set to "1" in hardware.

**(2) ADR1IS (DRI Address Counter 1 Interrupt Request Status) bit (Bit 1)**

If while DRI address counter 1 (DRIADR1CT) is enabled as the destination of transfer for the captured data the DRI transfer counter (DRITRMCT) underflows (H'0000 0000: count stop) upon reaching the terminal count, this bit is set to "1" in hardware.

**(3) OVREIS (Overrun Error Interrupt Request Status) bit (Bit 2)**

The DRI contains four 32-bit intermediate buffers to avoid losses of captured data arising from bus contention for RAM access with other bus masters. If a data capture event is detected while all of the buffers are full, this bit is set to "1" in hardware. In this case, the detected data capture event is ignored.

**(4) DCPEIS (Capture Enable Error Interrupt Request Status) bit (Bit 3)**

If the DCPEN (capture enable) bit in the DRI Data Capture Control Register (DRIDCAPCNT) changes state from "0" to "1" or the external event is detected before the DRI capture event counter (DRIDCAPCT) or the DRI transfer counter (DRITRMCT) underflows (H'0000 0000: count stop), this bit is set to "1."

**[Set condition]**

1. If any capture enable external event is selected by DEXSL (capture enable external source select) bit in the DRI Data Capture Control Register (DRIDCAPCNT); and
  - 1) when the selected external event is detected while DCPEN (capture enable) bit is enabled for data capture
  - 2) when the selected external event is detected before the DRI transfer counter (DRITRMCT) underflows (H'0000 0000:count stop)
2. If DCPEN (capture enable) bit is set to "1" from "0" in software before the DRI transfer counter underflows (H'0000 0000: count stop)

Notes: • In case of 1, the capture enable event is ignored.

- In case of 2, the DRI control unit should be initialized by clearing the DRI Transfer Control Register(DRITRMCNT) and DRI Data Capture Control Register(DRIDCAPCNT) to "0."

**(5) DTRFIS (DRI Transfer Counter Interrupt Request Status) bit (Bit 4)**

This bit is set when the DRI transfer counter (DRITRMCT) underflows (H'0000 0000: count stop) upon reaching the terminal count.

Note: • If the status is cleared in software at the same time it is set for an interrupt request generated, the latter has priority, so that the status is set.

DRI Transfer Interrupt Request Enable Register (DRITRMIEN)

&lt;Address: H'0080 2005&gt;

b8	9	10	11	12	13	14	b15
ADR0IEN	ADR1IEN	OVREIEN	DCPEIEN	DTRFIEN			
0	0	0	0	0	0	0	0

&lt;Upon exiting reset: H'00&gt;

b	Bit Name	Function	R	W
8	ADR0IEN DRI address counter 0 interrupt request enable bit	0: Mask (disable) interrupt request 1: Enable interrupt request	R	W
9	ADR1IEN DRI address counter 1 interrupt request enable bit			
10	OVREIEN Overrun error interrupt request enable bit			
11	DCPEIEN Capture enable error interrupt request enable bit			
12	DTRFIEN DRI transfer counter interrupt request enable bit			
13–15	No function assigned. Fix to "0."		0	0

This register disables or enables DRI transfer related interrupt requests.

Setting any bit in this register to "1" enables the corresponding interrupt request.

## 14.2.3 DRI Transfer Control Register

DRI Transfer Control Register (DRITRMCT)

&lt;Address: H'0080 2006&gt;

b0	1	2	3	4	5	6	b7
DRST	DBST	ADST	ADMD	ADSL			ADEV
0	0	0	0	0	0	0	0

&lt;Upon exiting reset: H'00&gt;

b	Bit Name	Function	R	W
0	DRST DRI reset bit	0: Reset DRI 1: Enable operation	R	W
1	DBST DRI buffer status bit	0: No data exists that has not been DRI transferred yet 1: Data exists that has not been DRI transferred yet	R	–
2	ADST Address counter status bit	0: DRI address counter 0 is active 1: DRI address counter 1 is active	R	–
3	ADMD Address counter operation mode select bit	0: Continuous mode 1: Reload mode	R	W
4, 5	ADSL Address counter select bit	00: Select DRI address counter 0 01: Select DRI address counter 1 10: Toggle between DRI address counters 0 and 1 11: Settings inhibited	R	W
6	No function assigned. Fix to "0."		0	0
7	ADEV Address counter switchover select bit	0: DRI transfer counter underflow 1: DEC4 underflow	R	W

**(1) DRST (DRI Reset) bit (Bit 0)**

This is a software reset bit of the DRI control unit. No data captures nor DRI transfers are performed while this bit = "0." This bit should be set to "1" to enable operation of the DRI. If this bit is cleared to "0" while the DRI is operating, the DRI capture control unit and the DRI transfer control unit both are initialized. Therefore, if any data exists in the DRI that has not been DRI transferred yet, all transfers for that data are canceled, and data captures are not performed either.

The following lists the registers and bits that are affected by this bit:

**1) ADST (Address counter status) bit**

If the DRST bit is cleared to "0" while ADSL (address counter select) bits = "10" (DRI address counters 0/1 toggled), the DRI address counter 0 (DRIADR0CT) is activated and ADST bit is cleared to "0."

**2) DBST (DRI buffer status) bit**

If the DRST bit is cleared to "0," this status bit is initialized to "0."

**3) DRI transfer counter (DRITRMCT)**

If the DRST bit is cleared to "0," the DRI transfer counter (DRITRMCT) is initialized to "0."

Notes: • DIN input processing control and DEC0–4 operations are not affected by setting or clearing the DRST bit.

- If the DRST bit changes state from "0" to "1" or vice versa, a finite time of 4 BCLKs is required before the new state takes effect. Changing the DRST bit again during that time is prohibited.
- If the DRST bit is set or cleared, a finite time of 1 BCLK is required before ADST bit and DBST bit are initialized.
- Changing any of ADMD (address counter operation mode select) bit, ADSL (address counter select) bit or ADVEN (address counter switchover select) bit while the DRST bit = "1" is prohibited.

**(2) DBST (DRI Buffer Status) bit (Bit 1)**

This bit indicates whether the internal DRI buffer contains any data that has not been DRI transferred yet. In order to avoid the data loss of Data transfer, middle buffer for 32 bits × 4 row is embedded in the inside of DRI. If the data is in this middle buffer, DBST bit shows "1." If it is not DBST bit shows "0" Also, when DRST bit is "0" cleared DBST bit is cleared as well.

**(3) ADST (Address Counter Status) bit (Bit 2)**

This bit indicates which DRI address counter, 0 or 1, is currently selected to specify the destination address of DRI transfer.

**(4) ADMD (Address Counter Operation Mode Select) bit (Bit 3)**

This bit selects operation modes of DRI address counters 0 (DRIADR0CT) and DRI address counter 1 (DRIADR1CT). Both DRI address counters operate in the same mode.

- **When continuous mode is selected**

The active DRI address counter is incremented by 4 each time a DRI transfer is completed after DRI transfer is enabled. In continuous mode, no DRI address reload register values are used.

- **When reload mode is selected**

When the DCPEN (capture enable) bit in the DRI Data Capture Control Register (DRIDCAPCNT) changes state from "0" to "1" (= enabled) after DRI transfer is enabled, the DRI address counter is reloaded with a count value from the corresponding DRI address reload register. Thereafter, the active DRI address counter is incremented by 4 each time a DRI transfer is completed.

Note: • If the bus width for the input data from external devices is chosen to be 8 bits, a DRI transfer is executed every four data capture events detected. Similarly, a DRI transfer is executed every two data capture events detected if the selected bus width is 16 bits or every data capture event detected if the selected bus width is 32 bits.

**(5) ADSL (Address Counter Select) bits (Bits 4, 5)**

The DRI contains two address counters to specify the internal RAM address to which data is transferred. These bits are used to select one of the two address counters.

- 1) **When DRI address counter 0 selected**

Data is transferred to the internal RAM address specified by DRI address counter 0 (DRIADR0CT).

- 2) **When DRI address counter 1 selected**

Data is transferred to the internal RAM address specified by DRI address counter 1 (DRIADR1CT).

- 3) **When DRI address counters 0 and 1 toggled**

The DRI address counters are switched over in hardware by an event selected by the ADEV (address counter switchover select) bit. After a microcomputer reset, DRI address counter 0 (DRIADR0CT) is active. When the DRST (DRI reset) bit is cleared to "0," the active DRI address counter is initialized to DRI address counter 0 (DRIADR0CT).

**(6) ADEV (Address Counter Switchover Select) bit (Bit 7)**

This bit is effective only when the ADSL (address counter select) bits are set to "10" (DRI address counters 0/1 toggled). This bit selects an event that causes the DRI address counter 0 (DRIADR0CT) and 1 (DRIADR1CT) that specify the destination address on the internal RAM of transfer to switch over.

Note: • If a DEC4 underflow is selected as the address counter switchover event, it is prohibited to select DIN4 event detection/capture event as the DEC4 count event.

### 14.2.4 DRI Special Mode Control Register

Selecting the special mode allows the DRI to be interfaced with external devices at still higher speed.

The width of input data bus during special mode is 8 or 16 bits. And data capturing timing (shown in Figure 14.2.6) can be selected when default timing. DI3 can only be selected for data synchronous signal.

Also, the event detection unit and data capture unit of the DRI are clocked by a signal whose transfer rate has been halved as shown in Figure 14.2.5.

DRI Special Mode Register (DRISPMOD)

<Address: H'0080 2007>

b8	9	10	11	12	13	14	b15
SPSSL		SPISL	SPMEN				
0	0	0	0	0	0	0	0

<Upon exiting reset: H'00>

b	Bit Name	Function	R	W
8	SPSSL DIN3 sampling edge select bit	0: Rising edge 1: Falling edge	R	W
9	No function assigned. Fix to "0."		0	0
10	SPISL Special mode control unit initialization DIN1 level select bit	0: "L" level 1: "H" level	R	W
11	SPMEN Special mode enable bit	0: Special mode off 1: Special mode on	R	W
12–15	No function assigned. Fix to "0."		0	0

#### (1) SPSSL (DIN3 Sampling Edge Select) bit (Bit 8)

Select the falling edge as the sampling edge for the transfer method shown in Figure 14.2.4, or the rising edge for the transfer method shown in Figure 14.2.3. This bit can only be changed while the DRST (DRI reset) bit in DRI transfer control register (DRITRMCNT) is "0." Note that the data synchronous clock signal during special mode is fixed to DIN3, and cannot be changed. In special mode, furthermore, the signal controlled by DIN3ED (DIN3 event detection control) bit in the DIN Input Processing Control Register (DINCNT) is the "output signal to the event detection unit" shown in Figure 14.2.5, and not the input signal from the DIN3 pin.

#### (2) SPISL (Special Mode Control Unit Initialization DIN1 Level Select) bit (Bit 10)

The special mode control circuit block can be initialized using the input signal supplied from DIN1. This bit selects the active level of the DIN1 signal by which said circuit is initialized. When DIN1 is driven to the initialization level, the output signals to the event detection unit and data capture unit all go "L," causing data sampling to stop. Conversely, when DIN1 is not at the initialization level, data sampling is performed at given internals and the signal shown in Figure 14.2.5 is passed to the event detection unit/data capture unit. Note that initialization function of the special mode control circuit block by DIN1 is not affected by setting of the DIN1ED bit in the DIN Input Processing Register (DINCNT). Note also that this bit can only be changed when the DRST (DRI reset) bit in the DRI Transfer Control Register (DRITRMCNT) = "0."

Note: • If DIN1 changes to the initialization level while the DCPEN (capture enable) bit in the DRI Data Capture Control Register (DRIDCAPCNT) = "1," the following problems may occur:

- 1) Erroneous data is taken in by the DRI.
- 2) Eight data prior to a change to the reset state are not taken in.

**(3) SPMEN (Special Mode Enable) bit (Bit 11)**

This bit selects whether to operate in special mode. If operation in special mode is selected, the following limitations apply.

## A) DRI Data Capture Control Register (DRIDCAPCNT)

**1) DWDSL (Input data bus width select) bit**

The data width that can be handled in special mode is limited to 8 or 16 bits. According to the handled data width, set the DWDSL bits as follows:

- If the input data is 8 bits wide, set the DWDSL bits to "01" (= 16 bits).
- If the input data is 16 bits wide, set the DWDSL bits to "10" (= 32 bits).

**2) DCPSL (Capture event select) bit**

Select DIN3.

**3) DTMSL (Capture timing select) bit**

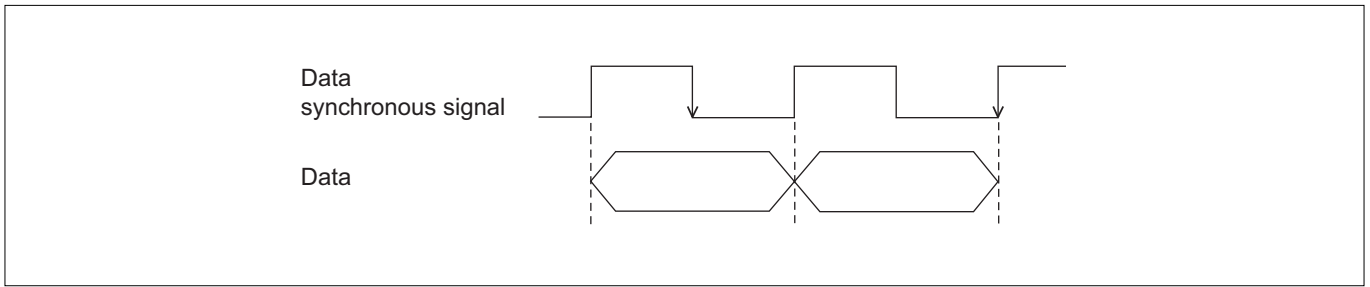
Select the default timing.

## B) DIN Input Processing Control Register (DINCNT)

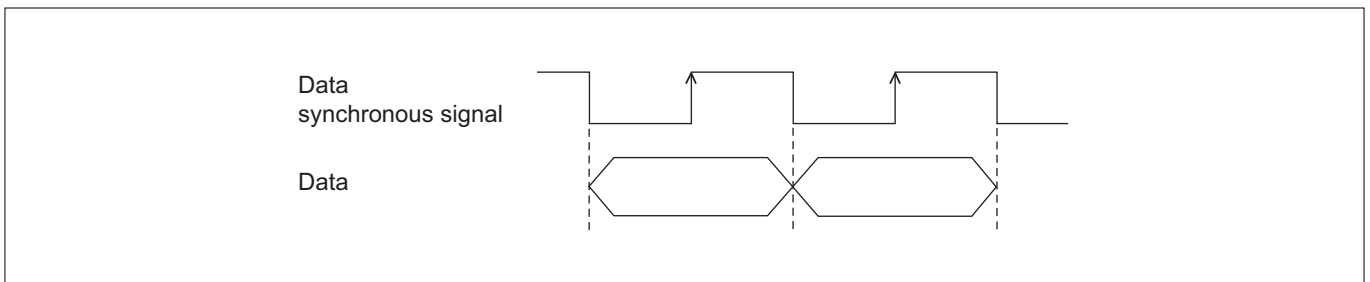
**1) DIN3ED (DIN3 event detection control) bit**

Select falling detection.

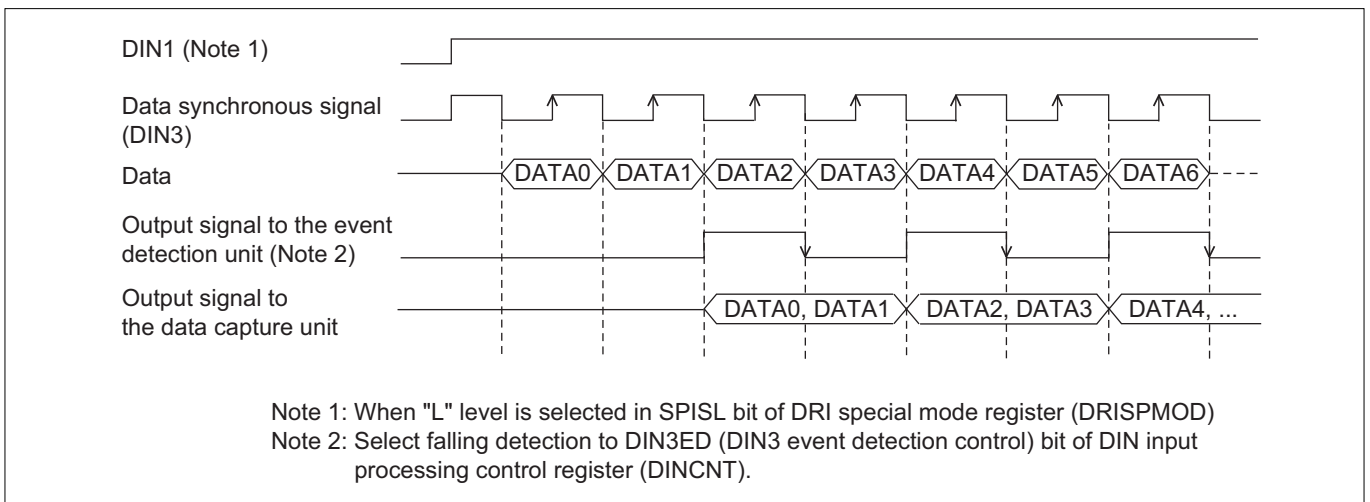
Note: • This register can only be set while the DRST (DRI reset) bit in the DRI Transfer Control Register (DRITRMCNT) = "0," i.e., while the DRI is reset.



**Figure 14.2.3 Data Transfer Method 1**



**Figure 14.2.4 Data Transfer Method 2**



**Figure 14.2.5 Timing Chart when Special Mode is On (DIN3 Sampling Edge: Rise)**

## 14.2.5 DRI Data Capture Control Register

DRI Data Capture Control Register (DRIDCAPCNT)

&lt;Address: H'0080 2008&gt;

b0	1	2	3	4	5	6	7	8	9	10	11	12	13	14	b15
DCPEN	DEXSL			DDSSL		DWDSL		DCPSL		DDSL	DWRPR	DTMSL			
0	0	0	0	0	0	0	0	0	0	0	0	0	0	0	0

&lt;Upon exiting reset: H'00&gt;

b	Bit Name	Function	R	W
0	DCPEN Capture enable bit	0: Disable capturing data 1: Enable capturing data	R	W
1–3	DEXSL Capture enable external source select bit	0XX: No external source selected 100: DIN0 event detection 101: DIN1 event detection 110: DIN2 event detection 111: DEC0 underflow	R	W
4, 5	DDSSL Capture external control disable souce select bit	00: No disable source selected 01: DRI capture event counter underflow 10: DEC3 underflow 11: DEC4 underflow	R	W
6, 7	DWDSL Input data bus width select bit	00: 8 bits 01: 16 bits 10: 32 bits 11: Settings inhibited	R	W
8, 9	DCPSL Capture event select bit	00: DIN2 event detection 01: DIN3 event detection 10: DIN4 event detection 11: DIN5 event detection	R	W
10	DDSL DD input 16-high order bit pin select bit	0: Select pin group A 1: Select pin group B	R	W
11	DWRPR Capture control WR protect bit	0: Enable WR 1: Disable WR	0	W
12–15	DTMSL Capture timing select bit	0000: Default 0001: 1 BCLK later 0010: 2 BCLK later 0011: 3 BCLK later 0100: 4 BCLK later 0101: 5 BCLK later 0110: 6 BCLK later 0111: 7 BCLK later 1000: 8 BCLK later 1001: 9 BCLK later 1010: 10 BCLK later 1011: 11 BCLK later 1100: 12 BCLK later 1101: 13 BCLK later 1110: 14 BCLK later 1111: 15 BCLK later	R	W

Note: • This register must always be accessed halfword (in 16 bits) units from the halfword boundary.

This register is used to make settings necessary to capture the input data that is fed in synchronously with an external clock signal. Before setting up this register, make sure the DRST (DRI reset) bit in the DRI Transfer Control Register (DRITRCNT) is set to "1." Also, if the DRST bit is cleared to "0," be sure to clear this register to "0."



**(1) DCPEN (Capture Enable) bit (Bit 0)**

When DCPEN = "1," the DRI is enabled for "capturing" data (i.e., taking in data into the internal RAM).

**[Set condition]**

- When explicitly set by writing "1" in software
- When the event selected by the DEXSL (capture enable external source select) bit is detected

**[Clear condition]**

- When explicitly cleared by writing "0" in software
- When the DRI capture event counter (DRIDCAPCT) underflows (H'0000 0000: stop counting) upon reaching the terminal count

- Notes:
- If an external source is selected by the DEXSL (capture enable external source select) bit, the bit cannot be set by writing "1" in software.
  - Before setting the bit by writing "1" in software, always be sure to check the DRI transfer counter to see that the counter is in an underflow state.

**(2) DEXSL (Capture Enable External Source Select) bits (Bits 1–3)**

These bits select an external source that causes DCPEN (capture enable) bit to be enabled for data capture. When the event selected here is detected, the capture enable bit is set to "1." If no external sources are selected, in no case will the capture enable bit be set by any external source. The external source or event selected by these bits can be cleared to "0" by using the DDSSL (capture external control disable source select) bit.

**(3) DDSSL (Capture External Control Disable Source Select) bits (Bits 4, 5)**

These bits select the external source or event to clear the capture enable external source select bits to "0."

**(4) DWDSL (Input Data Bus Width Select) bits (Bits 6, 7)**

These bits select the bus width of the input data supplied from external devices. If the bus width is chosen to be 8 bits, a DRI transfer is executed every four data capture events detected. Similarly, a DRI transfer is executed every two data capture events detected if the selected bus width is 16 bits or every data capture event detected if the selected bus width is 32 bits. Table 14.2.1 shows the relationship between each selected bus width and the data bits that are taken in.

- Note:
- When special mode is selected, the input data bus width select bits are subject to setting limitations. For details, refer to Section 14.2.4, "DRI Special Mode Control Register (DRISPMOD)."

**(5) DCPSL (Capture Event Select) bits (Bits 8, 9)**

These bits select an event at which data is taken in. In cases where the DRTS (DRI reset) bit in DRI transfer control register (DRITRMCNT) is enabled for operation, the capture enable bit is enabled for data capture and the interleaving control is in use, data is taken in when the selected event is detected while capture event detection conditions are met. If a data capture event is detected at the same time the DCPEN (capture enable) bit is set, data is taken in.

- Note:
- When special mode is selected, be sure to select DIN3 event detection.

**(6) DDSL (DD Input 16 High-Order Bit Pin Select) bit (Bit 10)**

Of the data inputs to the DRI, DD<sub>n</sub> (n = 0–31), pins for the 16 high-order bits (DD0–DD15) can be selected from two pin groups. This bit selects the pin group (the pin group A, B) to be used. However, for the other inputs DD16–DD31 are fixed. Table 14.2.2 lists pins in each pin group. If pin group A is selected, the DD Input Pin Select Register (DDSEL) should be set to specify which pins in DD0–DD3 to be used.

- Note:
- Port operation mode must be set separately from this register.

**(7) DWRPR (Capture Control WR Protect) bit (Bit 11)**

This bit controls writing to DCPEN (capture enable) bit and DEXSL (capture enable external source select) bit by enabling or disabling the access for write. If this bit is "0" when the register is accessed for write, the bits are write-enabled. If this bit is "1," the bits are write-protected.

**(8) DTMSL (Data Capture Timing Select) bit (Bits 12–15)**

These bits select the timing with which data is taken in after a data capture event is detected. The DRI detects an event on each falling edge of BCLK. When the default timing is selected, data is taken in synchronously with the falling edge of the same BCLK cycle in which an event is detected. With this as the starting point, data capture can be chosen to occur 1 BCLK to 15 BCLKs later. Figure 14.2.6 shows a data capture timing chart.

Note: • When special mode is selected, be sure to select the default timing.

**Table 14.2.1 Capture Data Positions**

	DD0–7	DD8–15	DD16–23	DD24–31
When 8 bits wide	Captured data		Don't care	
When 16 bits wide	Captured data			Don't care
When 32 bits wide	Captured data			

Notes: • When operating in special mode, the relationship between the actual data bus width and the register value set by the input data bus width select bits varies. For details, refer to "14.2.4 DRI Special Mode Control Register."

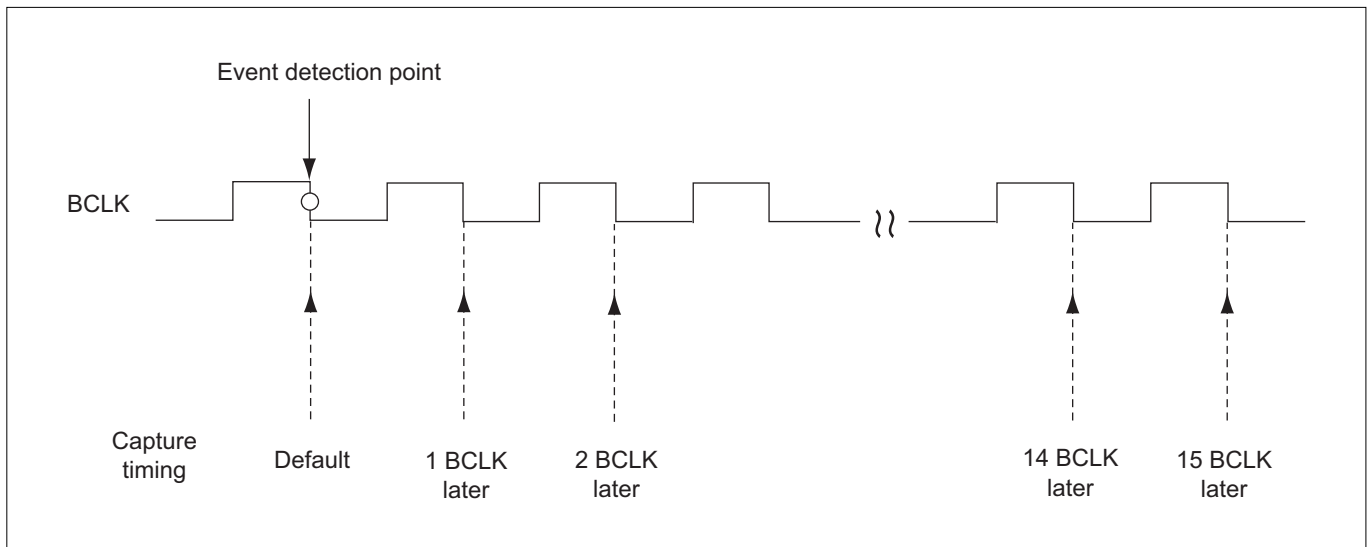
• DD0 is the MSB, and DD31 is the LSB.

**Table 14.2.2 Pins in Each Pin Group**

Function	Pin group A		Pin group B
	DD03SEL="0"	DD03SEL="1"	
DD0	P127/TCLK3/CS3#/DD0	P107/TO15/RXD4/DD0	P00/DB0/TO21/DD0
DD1	P126/TCLK2/CS2#/DD1	P106/TO14/TXD4/DD1	P01/DB1/TO22/DD1
DD2	P125/TCLK1/A10/DD2	P105/TO13/SCLKI4/SCLKO4/DD2	P02/DB2/TO23/DD2
DD3	P124/TCLK0/A9/DD3	P104/TO12/TIN25/DD3	P03/DB3/TO24/DD3
DD4	P117/TO7/TO36/DD4		P04/DB4/TO25/DD4
DD5	P116/TO6/TO35/DD5		P05/DB5/TO26/DD5
DD6	P115/TO5/TO34/DD6		P06/DB6/TO27/DD6
DD7	P114/TO4/TO33/DD7		P07/DB7/TO28/DD7
DD8	P113/TO3/TO32/DD8		P10/DB8/TO29/DD8
DD9	P112/TO2/TO31/DD9		P11/DB9/TO30/DD9
DD10	P111/TO1/TO30/DD10		P12/DB10/TO31/DD10
DD11	P110/TO0/TO29/DD11		P13/DB11/TO32/DD11
DD12	P97/TO20/DD12		P14/DB12/TO33/DD12
DD13	P96/TO19/DD13		P15/DB13/TO34/DD13
DD14	P95/TO18/RXD5/DD14		P16/DB14/TO35/DD14
DD15	P94/TO17/TXD5/DD15		P17/DB15/TO36/DD15

Notes: • Which pin groups (pin groups A or B) is used is selected in the DDSL bit.

• When pin group A is selected which pin is used for DD0 to DD3 is selected in DD03SEL of DDSEL register.



**Figure 14.2.6 Data Capture Timing**

### 14.2.6 DRI Data Interleave Control Register

DRI Data Interleave Control Register (DRIDSELCNT)

&lt;Address: H'0080 200A&gt;

b0	1	2	3	4	5	6	b7
DSD0	DSD1	DSD2	DSD3	DSD4			
0	0	0	0	0	0	0	0

&lt;Upon exiting reset: H'00&gt;

b	Bit Name	Function	R	W
0	DSD0 DEC0 data interleave control bit	0: Not interleaved 1: Interleaved by DEC0CT	R	W
1	DSD1 DEC1 data interleave control bit	0: Not interleaved 1: Interleaved by DEC1CT	R	W
2	DSD2 DEC2 data interleave control bit	0: Not interleaved 1: Interleaved by DEC2CT	R	W
3	DSD3 DEC3 data interleave control bit	0: Not interleaved 1: Interleaved by DEC3CT	R	W
4	DSD4 DEC4 data interleave control bit	0: Not interleaved 1: Interleaved by DEC4CT	R	W
5–7	No function assigned. Fix to "0."		0	0

The five event counters included in the DRI may be used to have the input data interleaved or "thinned out" in hardware before being taken in. Use this register to make interleave control related settings.

If the DEC<sub>n</sub> data interleave control bit (n = 0–4) is set to "0," the input data is not interleaved using the corresponding DEC<sub>n</sub> counter. If the DEC<sub>n</sub> data interleave control bit is set to "1," the input data is interleaved or "thinned out" because data is not taken in unless the corresponding DEC<sub>n</sub> counter is in an underflow state (count value = H'FFFF). If multiple event counters are selected for interleaving control data by this register, data is taken in for only a capture event that is input while all of the DEC<sub>n</sub> counters with their interleave control bits set to "1" are in an underflow state.

Note: • The next event occurring after a counter underflow and those that follow are effective as the capture event.

### 14.2.7 DIN Input Event Select Register

DIN Input Event Select Register (DINSEL)

&lt;Address: H'0080 200B&gt;

b8	9	10	11	12	13	14	b15
						DIN5SL	
0	0	0	0	0	0	0	0

&lt;Upon exiting reset: H'00&gt;

b	Bit Name	Function	R	W
8–13	No function assigned. Fix to "0."		0	0
14, 15	DIN5SL DIN5 input event select bit	00: F/F19 (TIO8) 01: F/F8 (TOP8) 10: F/F28 (TOU0_7) 11: F/F36 (TOU1_7)	R	W

The value of flip-flop, which is selected by the DIN5SL bit, is fed as an input signal to the DIN5 input processing circuit.

## 14.2.8 DD Input Enable Registers

DD Input Enable Register 0 (DRIDDEN0)

&lt;Address: H'0080 200C&gt;

b0	1	2	3	4	5	6	b7
DD0EN	DD1EN	DD2EN	DD3EN	DD4EN	DD5EN	DD6EN	DD7EN
0	0	0	0	0	0	0	0

&lt;Upon exiting reset: H'00&gt;

b	Bit Name	Function	R	W
0	DD0EN (DD0 input enable bit)	0: Disable input	R	W
1	DD1EN (DD1 input enable bit)	1: Enable input		
2	DD2EN (DD2 input enable bit)			
3	DD3EN (DD3 input enable bit)			
4	DD4EN (DD4 input enable bit)			
5	DD5EN (DD5 input enable bit)			
6	DD6EN (DD6 input enable bit)			
7	DD7EN (DD7 input enable bit)			

DD Input Enable Register 1 (DRIDDEN1)

&lt;Address: H'0080 200D&gt;

b8	9	10	11	12	13	14	b15
DD8EN	DD9EN	DD10EN	DD11EN	DD12EN	DD13EN	DD14EN	DD15EN
0	0	0	0	0	0	0	0

&lt;Upon exiting reset: H'00&gt;

b	Bit Name	Function	R	W
8	DD8EN (DD8 input enable bit)	0: Disable input	R	W
9	DD9EN (DD9 input enable bit)	1: Enable input		
10	DD10EN (DD10 input enable bit)			
11	DD11EN (DD11 input enable bit)			
12	DD12EN (DD12 input enable bit)			
13	DD13EN (DD13 input enable bit)			
14	DD14EN (DD14 input enable bit)			
15	DD15EN (DD15 input enable bit)			

DD Input Enable Register 2 (DRIDDEN2)

&lt;Address: H'0080 200E&gt;

b0	1	2	3	4	5	6	b7
DD16EN	DD17EN	DD18EN	DD19EN	DD20EN	DD21EN	DD22EN	DD23EN
0	0	0	0	0	0	0	0

&lt;Upon exiting reset: H'00&gt;

b	Bit Name	Function	R	W
0	DD16EN (DD16 input enable bit)	0: Disable input	R	W
1	DD17EN (DD17 input enable bit)	1: Enable input		
2	DD18EN (DD18 input enable bit)			
3	DD19EN (DD19 input enable bit)			
4	DD20EN (DD20 input enable bit)			
5	DD21EN (DD21 input enable bit)			
6	DD22EN (DD22 input enable bit)			
7	DD23EN (DD23 input enable bit)			

DD Input Enable Register 3 (DRIDDEN3)

<Address: H'0080 200F>

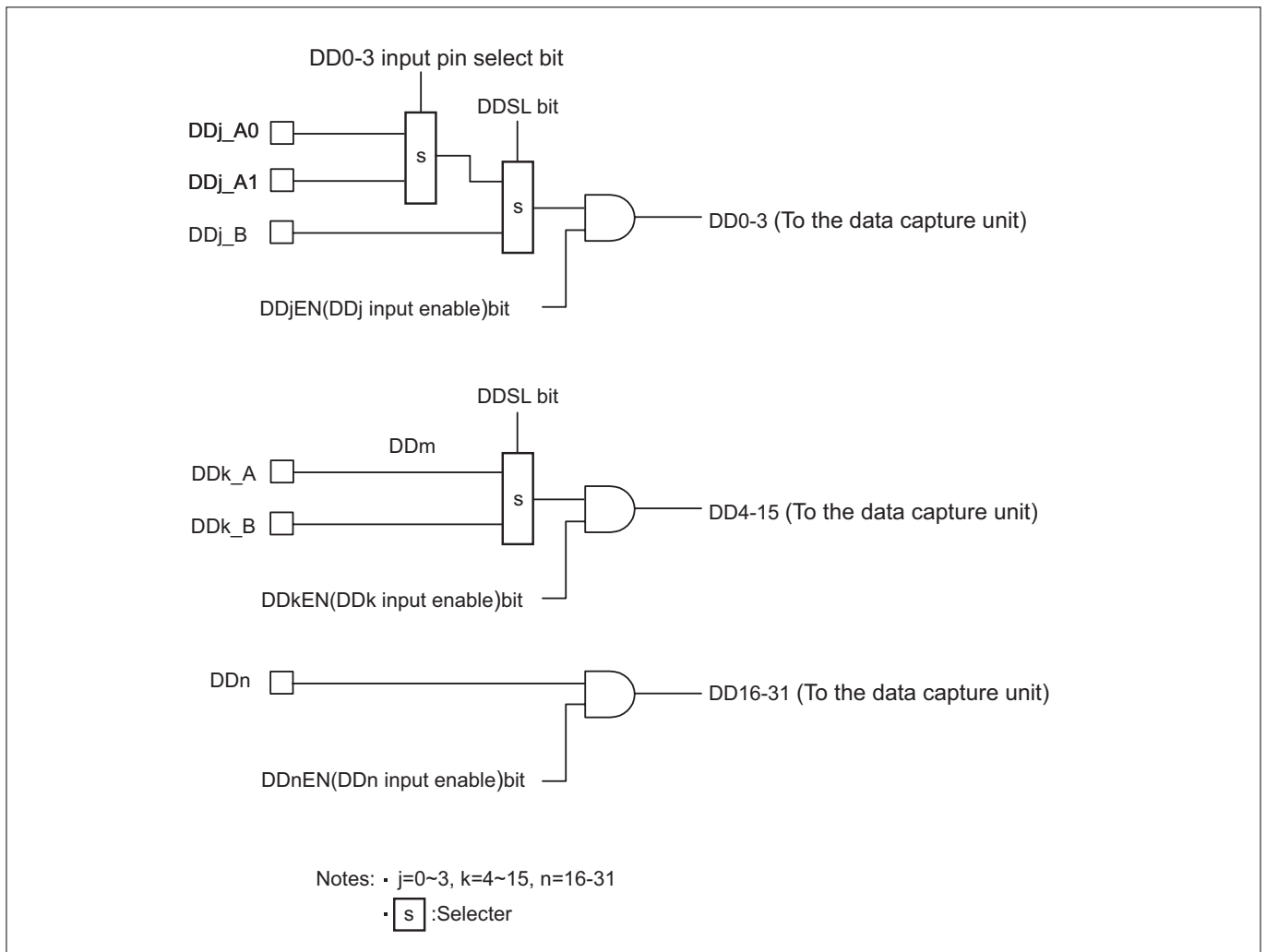
b8	9	10	11	12	13	14	b15
DD24EN	DD25EN	DD26EN	DD27EN	DD28EN	DD29EN	DD30EN	DD31EN
0	0	0	0	0	0	0	0

<Upon exiting reset: H'00>

b	Bit Name	Function	R	W
8	DD24EN (DD24 input enable bit)	0: Disable input	R	W
9	DD25EN (DD25 input enable bit)	1: Enable input		
10	DD26EN (DD26 input enable bit)			
11	DD27EN (DD27 input enable bit)			
12	DD28EN (DD28 input enable bit)			
13	DD29EN (DD29 input enable bit)			
14	DD30EN (DD30 input enable bit)			
15	DD31EN (DD31 input enable bit)			

The DD Input Enable Register "n" (n = 0–3) controls data input to the DRI by disabling or enabling the data input. If the DDn input enable bit is set to "0," input to the DRI is always fixed to "0" irrespective of the corresponding pin input level. If the DDn input enable bit is set to "1," data input to the DRI is taken in according to the corresponding pin input level.

Figure 14.2.7 schematically shows a DD input block diagram.

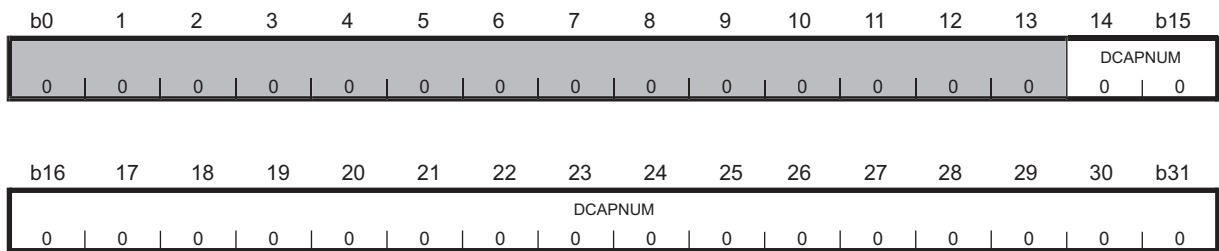


**Figure 14.2.7 Block Diagram of DD Input**

## 14.2.9 DRI Data Capture Event Count Setting Register

DRI Data Capture Event Count Setting Register (DRIDCAPNUM)

&lt;Address: H'0080 2010&gt;



&lt;Upon exiting reset: H'0000 0000&gt;

b	Bit Name	Function	R	W
0–13	No function assigned. Fix to "0."		0	0
14–31	DCAPNUM Transfer Event Count		R	W

Note: • This register must always be accessed in halfword or word units beginning with even addresses.

This register is used to set the number of events, at occurrence of which data is taken in.

The value set in this register is used as the reload value for the DRI capture event counter (DRIDCAPCT) and the DRI transfer counter (DRITRMCT). Since the DRI performs data transfers in 32-bit units, make sure the value set in this register satisfies the requirement given below depending on how DWDSL (input data bus width select) bits in the DRI Data Capture Control Register are set:

- When selected to be 8 bits, a multiple of 4 (equal to or greater than 4)
- When selected to be 16 bits, a multiple of 2 (equal to or greater than 2)
- When selected to be 32 bits, any value (equal to or greater than 1)

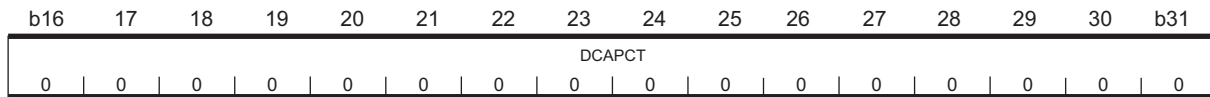
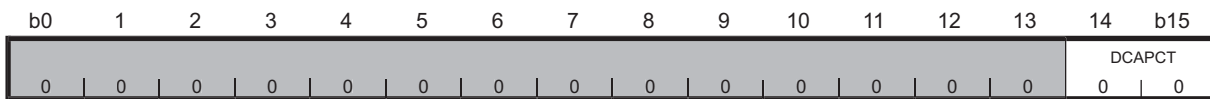
Also be careful that the total amount of captured data will not exceed the RAM area supported by the DRI.

Note: • This register can only be rewritten when DCPEN (capture enable) bit in the DRI Data Capture Control Register = "0."

## 14.2.10 DRI Capture Event Counter

DRI Capture Event Counter (DRIDCAPCT)

&lt;Address: H'0080 2014&gt;



&lt;Upon exiting reset: H'0000 0000&gt;

b	Bit Name	Function	R	W
0–13	No function assigned. Fix to "0."		0	0
14–31	DCAPCT Capture event counter		R	–

Note: • This register must always be accessed in word (32 bit) units from the halfword boundaries (The lower address B'00).

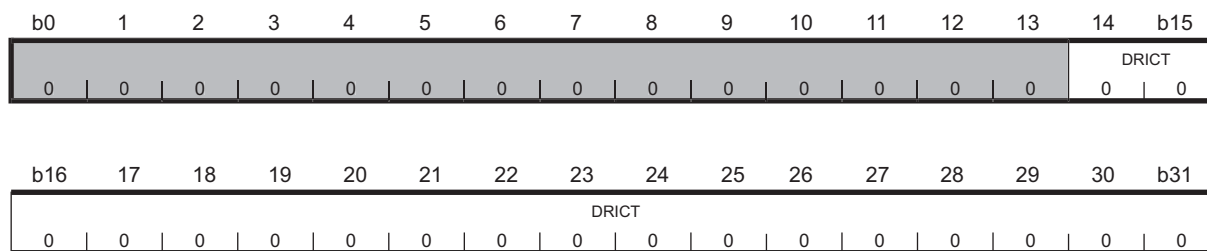
The DRI Capture Event Counter is an 18-bit counter to count data capture events. When DCPEN (capture enable) bit in the DRI Data Capture Control Register (DRIDCAPCNT) changes state from data capture disabled to enabled, this counter is reloaded with the value of the DRI Data Capture Event Count Setting Register (DRIDCAPNUM). Thereafter, the counter is decremented by one each time data is taken in. Then, when the DRI capture event counter is decremented to H'0000 0000, it stops counting.



## 14.2.11 DRI Transfer Counter

DRI Transfer Counter (DRITRMCT)

&lt;Address: H'0080 2018&gt;



&lt;Upon exiting reset: H'0000 0000&gt;

b	Bit Name	Function	R	W
0–13	No function assigned. Fix to "0."		0	0
14–31	DRICT DRI transfer counter		R	–

Note: • This register must always be accessed wordwise (32 bits) beginning with the address of the DRI Transfer Counter (Upper).

The DRI Transfer Counter is an 18-bit counter to count DRI transfers. When DCPEN (capture enable) bit in the DRI Data Capture Control Register (DRIDCAPCNT) changes state from data capture disabled to enabled, this counter is reloaded with one of the values shown below, depending on how the DRI Data Capture Event Count Setting Register (DRIDCAPNUM) and DWDSL (input data bus width select) bits are set.

- When selected to be 8 bits, the value set in the DRI Data Capture Event Count Setting Register (DRIDCAPNUM) divided by 4
- When selected to be 16 bits, the value set in the DRI Data Capture Event Count Setting Register (DRIDCAPNUM) divided by 2
- When selected to be 32 bits, the value set in the DRI Data Capture Event Count Setting Register (DRIDCAPNUM)

If the bus width for the input data from external devices is chosen to be 8 bits, a DRI transfer is executed every four data capture events detected. Similarly, a DRI transfer is executed every two data capture events detected if the selected bus width is 16 bits or every data capture event detected if the selected bus width is 32 bits. The counter is decremented by one each time a DRI transfer finishes. Then, when the counter underflows (H'0000 0000), it stops counting. And Underflow of DRI transfer counter indicates H'0000 0000 (counter stop).

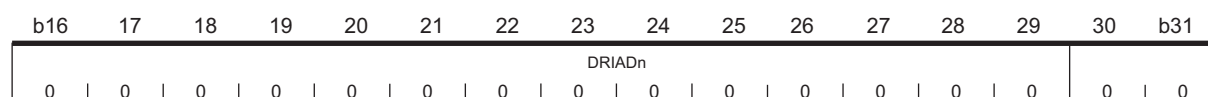
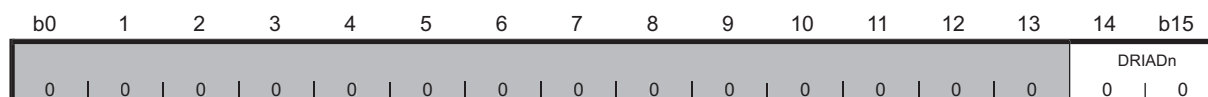
## 14.2.12 DRI Address Counters

DRI Address Counter 0 (DRIADR0CT)

&lt;Address: H'0080 2024&gt;

DRI Address Counter 1 (DRIADR1CT)

&lt;Address: H'0080 202C&gt;



&lt;Upon exiting reset: H'0000 0000&gt;

b	Bit Name	Function	R	W
0–13	No function assigned. Fix to "0."		0	0
14–29	DRIADn Destination address A14–A29		R	W
30, 31	Destination address A30, A31 (Must always be fixed to "0")		0	0

Note: • This register must always be accessed wordwise (32 bits) beginning with the word boundary (The lower address B'00).

DRI Address Counters 0 and 1 are used to specify the destination address A14–A29 in the internal RAM to which data is DRI transferred. The address A30–A31 are fixed to "0." The counter is incremented by 4 each time a DRI transfer finishes. DRI Address Counters have two operation modes to choose from. For details, refer to "14.2.3 DRI Transfer Control Register."

- Notes
- If the DRI address counter value is outside the mapped area of the internal RAM, the captured data is not written to any location although the DRI behaves as if a DRI transfer had terminated normally.
  - The address counter that is incremented by 4 when a DRI transfer has finished is DRI Address Counter 0 or 1 whichever is active as set by ADSL (address counter select) bit in the DRI TransferControl Register (DRITRMCT).
  - These registers can only be rewritten when the DRI transfer counter (DRITRMCT) is in an underflow state (H'0000 0000 counter: counter stop).

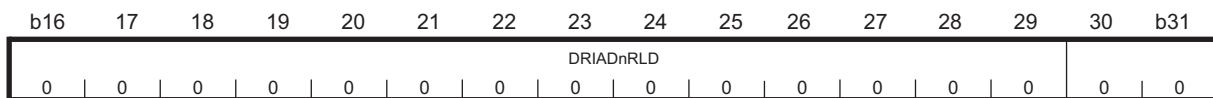
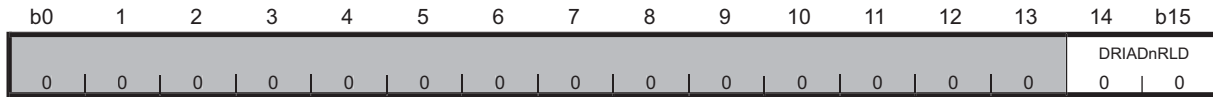
#### 14.2.13 DRI Address Reload Registers

DRI Address Reload Register 0 (DRIADR0RLD)

<Address: H'0080 2020>

DRI Address Reload Register 1 (DRIADR1RLD)

<Address: H'0080 2028>



<Upon exiting reset: H'0000 0000>

b	Bit Name	Function	R	W
0–13	No function assigned. Fix to "0."		0	0
14–29	DRIADnRLD	A14-A29 reload value	R	W
30, 31	A30, A31 reload value (Must always be fixed to "0")		0	0

Note: • These registers must always be accessed in halfword or word units beginning with even addresses.

These registers are used to store the values to be reloaded into DRI Address Counters 0 and 1. If reload mode is selected by ADMD (address counter operation mode select) bit in the DRI Transfer Control Register (DRITRMCNT), the value set in either reload register is reloaded into the corresponding DRI Address Counter when DCPEN (capture enable) bit in the DRI Data Capture Control Register (DRIDCAPCNT) changes from "0" to "1."

Note: • These registers can only be rewritten when DCPEN (capture enable) bit in the DRI Data Capture Control Register (DRIDCAPCNT) is "0."

## 14.2.14 DIN Input Processing Control Register

DIN Input Processing Control Register (DINCNT)

&lt;Address: H'0080 2030&gt;

b0	1	2	3	4	5	6	7	8	9	10	11	12	13	14	b15
DIN0ED		DIN1ED		DIN2ED		DIN3ED		DIN4ED		DIN5ED					
0	0	0	0	0	0	0	0	0	0	0	0	0	0	0	0

&lt;Upon exiting reset: H'0000&gt;

b	Bit Name	Function	R	W
0, 1	DIN0ED DIN0 event detection control bit	00: Input has no effect 01: Detect on rising edge	R	W
2, 3	DIN1ED DIN1 event detection control bit	10: Detect on falling edge 11: Detect on both edges		
4, 5	DIN2ED DIN2 event detection control bit			
6, 7	DIN3ED DIN3 event detection control bit			
8, 9	DIN4ED DIN4 event detection control bit			
10, 11	DIN5ED DIN5 event detection control bit			
12–15	No function assigned. Fix to "0."		0	0

Note: • This register must always be accessed in halfword (16 bit) units from the halfword boundaries.

These bits specify the event detection of the input signal as it is fed in from devices external to the DRI. The event detection can be selected from three choices: rising edge, falling edge or both edges. The value "00" (input has no effect) is selected, no events are detected. Table 14.2.3 shows the relationship between each DINn event detection circuit and the input signals fed in from devices external to the DRI.

Note: • For the DIN3 event detection circuit, the input event signal varies depending on whether DRI special mode is on or off.

Table 14.2.3 Relationship between Event Detection and Pins

	Special Mode OFF	Special Mode ON
DIN0 event detection circuit	P130/TIN16/PWMOFF0/DIN0	←
DIN1 event detection circuit	P131/TIN17/PWMOFF1/DIN1	←
DIN2 event detection circuit	P132/TIN18/DIN2	←
DIN3 event detection circuit	P133/TIN19/DIN3	Output DIN3 divide by 2
DIN4 event detection circuit	P134/TIN20/TXD3/DIN4	←
DIN5 event detection circuit	Selected by DIN input event select register	←

## 14.2.15 DRI Event Counter (DEC) Control Registers

DEC0 Control Register (DEC0CNT)

&lt;Address: H'0080 2032&gt;

b0	1	2	3	4	5	6	b7
DEC0EN	DEC0EXT			DEC0CS		0	DEC0MOD
0	0	0	0	0	0	0	0

&lt;Upon exiting reset: H'00&gt;

b	Bit Name	Function	R	W
0	DEC0EN DEC0 count enable bit	0: Disable count 1: Enable count	R	W
1–3	DEC0EXT DEC0 count enable source select bit	0XX: Disable external source 100: DIN0 event detection 101: DIN1 event detection 110: DIN2 event detection 111: Capture enable	R	W
4, 5	DEC0CS DEC0 count event select bit	00: DIN0 event detection 01: DIN1 event detection 10: DIN2 event detection 11: DRI capture event counter underflow	R	W
6	No function assigned. Fix to "0."		0	0
7	DEC0MOD DEC0 operation mode select bit	0: Single-shot mode 1: Continuous operation mode	R	W

DEC1 Control Register (DEC1CNT)

&lt;Address: H'0080 2038&gt;

b0	1	2	3	4	5	6	b7
DEC1EN	DEC1EXT			DEC1CS		0	DEC1MOD
0	0	0	0	0	0	0	0

&lt;Upon exiting reset: H'00&gt;

b	Bit Name	Function	R	W
0	DEC1EN DEC1 count enable bit	0: Disable count 1: Enable count	R	W
1–3	DEC1EXT DEC1 count enable source select bit	0XX: Disable external source 100: DIN0 event detection 101: DIN1 event detection 110: DEC0 underflow 111: Capture enable	R	W
4, 5	DEC1CS DEC1 count event select bit	00: DIN1 event detection 01: DIN2 event detection 10: DIN3 event detection 11: DEC0 underflow	R	W
6	No function assigned. Fix to "0."		0	0
7	DEC1MOD DEC1 operation mode select bit	0: Single-shot mode 1: Continuous operation mode	R	W

DEC2 Control Register (DEC2CNT)

&lt;Address: H'0080 203E&gt;

b0	1	2	3	4	5	6	b7
DEC2EN	DEC2EXT			DEC2CS		0	DEC2MOD
0	0	0	0	0	0	0	0

&lt;Upon exiting reset: H'00&gt;

b	Bit Name	Function	R	W
0	DEC2EN DEC2 count enable bit	0: Disable count 1: Enable count	R	W
1–3	DEC2EXT DEC2 count enable source select bit	0XX: Disable external source 100: DIN0 event detection 101: DIN1 event detection 110: DIN2 event detection 111: Capture enable	R	W
4, 5	DEC2CS DEC2 count event select bit	00: DIN1 event detection 01: DIN2 event detection 10: DIN3 event detection 11: Capture event	R	W
6	No function assigned. Fix to "0."		0	0
7	DEC2MOD DEC2 operation mode select bit	0: Single-shot mode 1: Continuous operation mode	R	W

DEC3 Control Register (DEC3CNT)

&lt;Address: H'0080 2044&gt;

b0	1	2	3	4	5	6	b7
DEC3EN	DEC3EXT			DEC3CS		0	DEC3MOD
0	0	0	0	0	0	0	0

&lt;Upon exiting reset: H'00&gt;

b	Bit Name	Function	R	W
0	DEC3EN DEC3 count enable bit	0: Disable count 1: Enable count	R	W
1–3	DEC3EXT DEC3 count enable source select bit	0XX: Disable external source 100: DIN0 event detection 101: DIN1 event detection 110: DEC2 underflow 111: Capture enable	R	W
4, 5	DEC3CS DEC3 count event select bit	00: DIN2 event detection 01: DIN3 event detection 10: DIN4 event detection 11: DIN5 event detection	R	W
6	No function assigned. Fix to "0."		0	0
7	DEC3MOD DEC3 operation mode select bit	0: Single-shot mode 1: Continuous operation mode	R	W

DEC4 Control Register (DEC4CNT)

&lt;Address: H'0080 204A&gt;

b0	1	2	3	4	5	6	b7
DEC4EN	DEC4EXT			DEC4CS			DEC4MOD
0	0	0	0	0	0	0	0

&lt;Upon exiting reset: H'00&gt;

b	Bit Name	Function	R	W
0	DEC4EN DEC4 count enable bit	0: Disable count 1: Enable count	R	W
1–3	DEC4EXT DEC4 count enable source select bit	0XX: Disable external source 100: DIN0 event detection 101: DIN1 event detection 110: DEC3 underflow 111: Capture enable	R	W
4, 5	DEC4CS DEC4 count event select bit	00: DIN4 event detection 01: Capture event 10: One DRI transfer completed 11: DRI transfer counter underflow	R	W
6	No function assigned. Fix to "0."		0	0
7	DEC4MOD DEC4 operation mode select bit	0: Single-shot mode 1: Continuous operation mode	R	W

These registers are used to control the internal event counters DECn of the DRI.

#### (1) DECnEN (DECn Count Enable) bit (Bit 0)

This bit controls DECn count operation by enabling or disabling the count operation. This bit can be set to "1" by an external event. Furthermore, if single-shot operation mode is selected, this bit is cleared to "0" in hardware by a DECn counter underflow.

##### [Set condition to "1"]

- When explicitly set by writing "1" in software
- When the event selected by DECnEXT (DECn count enable source select) bit occurs

##### [Clear condition to "0"]

- When explicitly cleared by writing "0" in software
- When DECn counter underflows while operating in single-shot mode

Note: • If an external source is selected by DECnEXT (DECn count enable source select) bit, this bit cannot be set by writing "1" in software.

#### (2) DECnEXT (DECn Count Enable Source Select) bits (Bits 1–3)

If DECn counter (DECnCT) needs to be enabled for counting by an external event, use these bits to select the count enable source. When an event is detected by the selected source, DECnEN (DECn count enable) bit is set to "1."

#### (3) DECnCS (DECn Count Event Select) bits (Bits 4, 5)

These bits select the event that causes DECn counter (DECnCT) to count. When the event selected from factor that DECnEN (DECn count enable) bit = "1" is detected, the count value of DECn counter (DECnCT) is decremented by one.

#### (4) DECnMOD (DECn Operation Mode Select) bit (Bit 7)

This bit selects operation mode of DECn counter (DECnCT).

### • Single-shot Mode

When DECnEN (DECn count enable) bit changes from "disabled" to "enabled," the DECn counter (DECnCT) is loaded with the content of the DECn reload register (DECnRLD). Thereafter, the counter counts down each time the event selected by the DECnCS (DECn count event select) bit occurs. When event occurrences equal to the DECn Reload Register (DECnRLD) set value + 1 have been counted, the counter underflows (count value = H'FFFF) and stops counting, at which time DECnEN (DECn count enable) bit is cleared to "0."

- Notes:
- The reload value loaded into the counter cannot be read out while count is enabled. If the counter is accessed for read, the count value before being reloaded is read out.
  - If the count is enabled by an external event at the same time the count source occurs, the count enable bit is set to "1" by the external event, but the counter does not count.
  - If the counter stops counting upon underflowing at the same time count is enabled by an external event, the former has priority so that the counter stops.
  - If the count is enabled by external event at the same time the count enable bit is disabled by writing 0 in software, the latter has priority so the count is disabled.

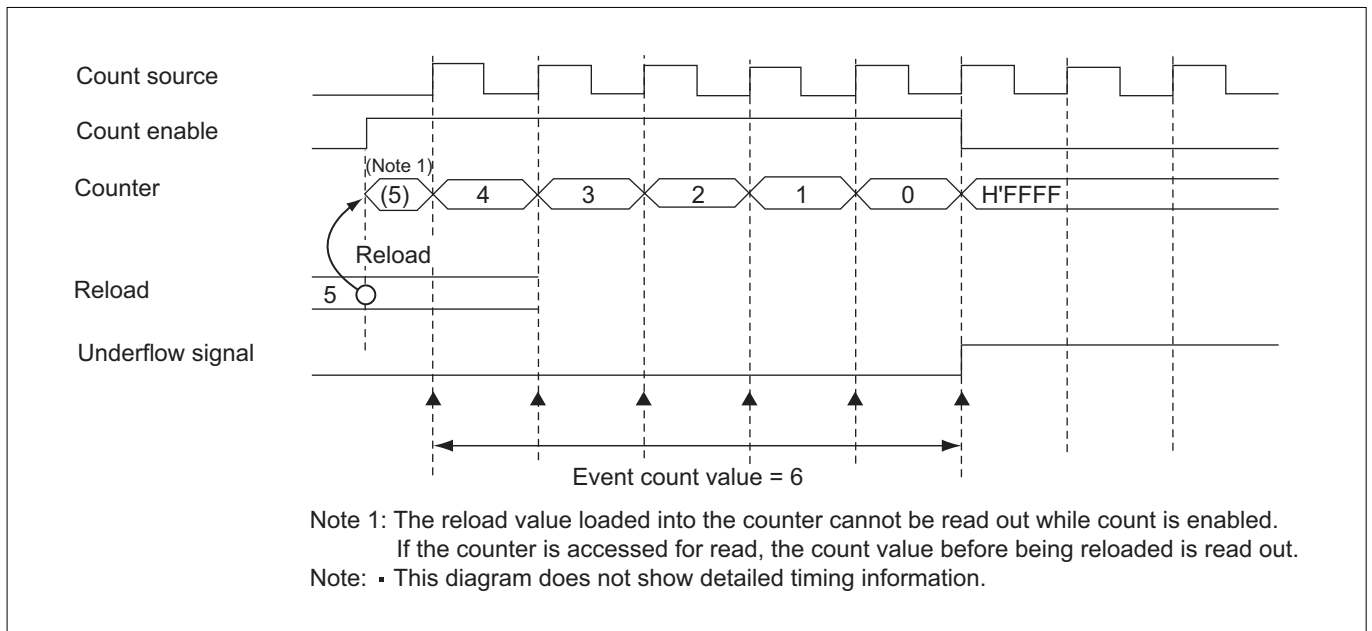


Figure 14.2.8 Example DEC Count Operation in Single-shot Mode



### • Continuous Operation Mode

When DECnEN (DECn count enable) bit is enabled, the counter starts counting down from the DECn counter (DECnCT) set value each time the event selected by the DECnCS (DECn count event select) bit occurs. Then, when the DECn counter (DECnCT) underflows (counter value = H'FFFF), the counter is reloaded with the value of the DECn reload register (DECnRDL). Thereafter, this operation is repeated each time the DECn counter (DECnCT) underflows.

- Notes:
- When a reload occurs, the value reloaded into the counter cannot be read out. If the counter is accessed for read, H'FFFF (underflow value) is read out.
  - If the count is enabled by an external event at the same time the count source occurs, the count enable bit is set to "1" by the external event, but the counter does not count.
  - If the count is enabled by external event at the same time DECnEN (count enable) bit is disabled by writing 0 in software, the latter has priority so the count is disabled.
  - When reload and writing to counter are occurred at same time, writing to counter has priority. Interrupt by DECn counter underflow is not occurred at that time.
  - When count source and writing to counter are occurred at same time, writing to counter has priority. Count source is ignored at that time.

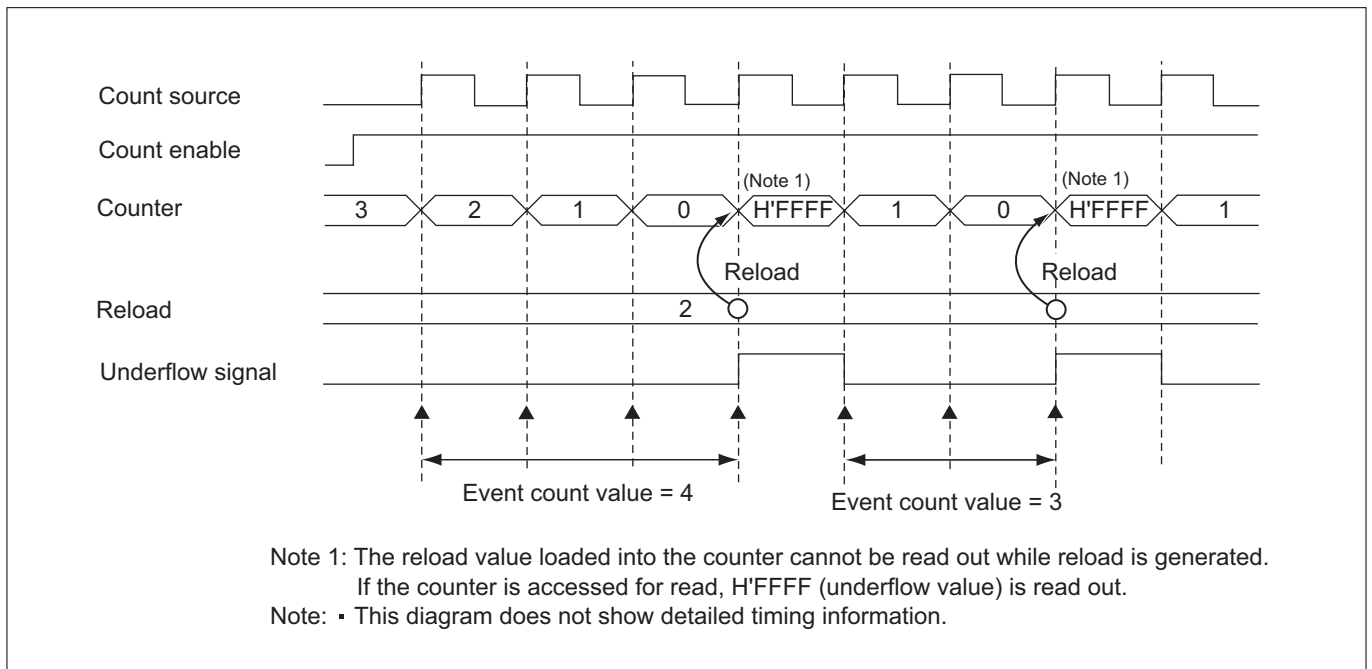
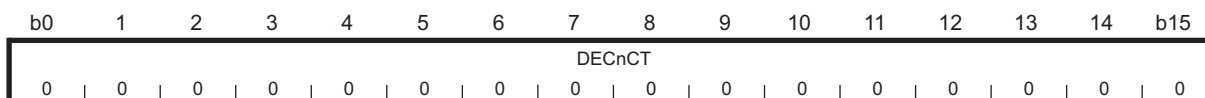


Figure 14.2.9 Example DEC Count Operation in Continuous Mode

### 14.2.16 DRI Event Counters (DEC Counters)

DEC0 Counter (DEC0CT)	<Address: H'0080 2036>
DEC1 Counter (DEC1CT)	<Address: H'0080 203C>
DEC2 Counter (DEC2CT)	<Address: H'0080 2042>
DEC3 Counter (DEC3CT)	<Address: H'0080 2048>
DEC4 Counter (DEC4CT)	<Address: H'0080 204E>



<Upon exiting reset: H'0000>

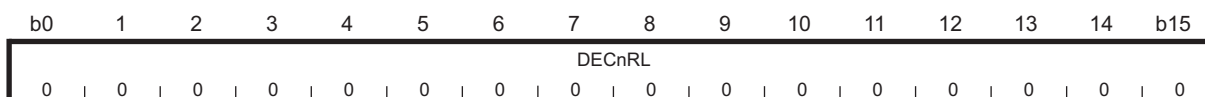
b	Bit Name	Function	R	W
0–15	DECnCT DECn counter		R	W

Note: • This register must always be accessed in halfword (16 bits) units from the halfword boundaries.

The DECn Counter, which is a 16-bit down counter, starts counting synchronously with event detection after count is enabled. When DECn counter is used in one-shot mode, do not write to the DECn counter while count is enabled.

### 14.2.17 DRI Event Counter (DEC) Reload Registers

DEC0 Reload Register (DEC0RLD)	<Address: H'0080 2034>
DEC1 Reload Register (DEC1RLD)	<Address: H'0080 203A>
DEC2 Reload Register (DEC2RLD)	<Address: H'0080 2040>
DEC3 Reload Register (DEC3RLD)	<Address: H'0080 2046>
DEC4 Reload Register (DEC4RLD)	<Address: H'0080 204C>



<Upon exiting reset: H'0000>

b	Bit Name	Function	R	W
0–15	DECnRL DECn reload value		R	W

Note: • This register must always be accessed in halfword (16 bits) units from the halfword boundaries.

The DECn Reload Register is used to reload the DECn Counter with data. The counter is reloaded with the content of the reload register in the following cases:

- When count is enabled while being disabled in single-shot mode
- When the DECn counter underflows while operating in continuous operation mode

### 14.3 Notes on DRI

Precautions about the DRI is shown below.

- In order that the data writing from DRI and RTD to internal RAM use the exclusive bus prepared apart from M32 R-FPU, do not usually generate the competition with access from other bus masters (CPU, DMA, NBD, SDI). However DRI transfer, RTD transfer and the access (read-out/writing) from other bus master occur at the same time for areas of the 16-K byte unit of internal RAM, access competition occurs. When access competition occurs, mediation is operated according to the following priority.

NBD/SDI > DMA > CPU > DRI > RTD

This page is blank for reasons of layout.

## **CHAPTER 15**

---

# **REAL TIME DEBUGGER (RTD)**

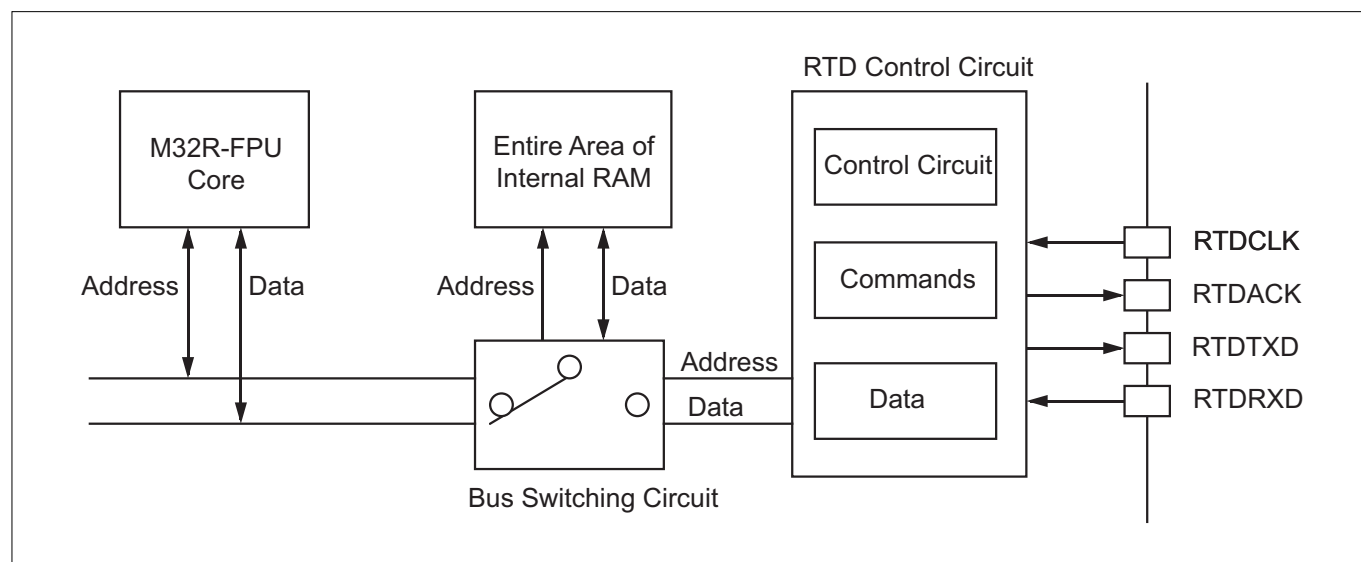
- 15.1 Outline of the Real-Time Debugger (RTD)
- 15.2 Pin Functions of the RTD
- 15.3 RTD Related Register
- 15.4 Functional Description of the RTD
- 15.5 Typical Connection with the Host

## 15.1 Outline of the Real-Time Debugger (RTD)

The Real-Time Debugger (RTD) is a serial interface through which to read or write to any location in the entire area of the internal RAM by using commands from outside the microcomputer. Because data transfers between the RTD and internal RAM are performed via a dedicated internal bus independently of the M32R-FPU, RTD operation can be controlled without the need to stop the M32R-FPU.

**Table 15.1.1 Outline of the Real-Time Debugger (RTD)**

Item	Description
Transfer method	Clock-synchronous serial interface
Generation of transfer clock	Generated by external host
RAM access area	Entire area of the internal RAM (controlled by A14–A29)
Transmit/receive data length	32 bits (fixed)
Bit transfer sequence	LSB first
Maximum transfer rate	2 Mbits/second
Input/output pins	4 pins (RTDCLK, RTDRXD, RTDACK, RTDCLK)
Number of commands	Following five functions <ul style="list-style-type: none"> <li>• Monitor continuously</li> <li>• Output real-time RAM content</li> <li>• Forcibly rewrite RAM content (with verify)</li> <li>• Recover from runaway condition</li> <li>• Request RTD interrupt</li> </ul>



**Figure 15.1.1 Block Diagram of the Real-Time Debugger (RTD)**

## 15.2 Pin Functions of the RTD

Pin Functions of the RTD are shown below.

**Table 15.2.1 Pin Functions of the RTD**

Pin Name	Type	Function
RTDTXD	Output	RTD serial data output
RTDRXD	Input	RTD serial data input
RTDACK	Output	Output a "L" level pulse synchronously with the beginning clock edge of the output data word. The width of this pulse indicates the type of instruction or data the RTD has received. 1 clock period : VER (continuous monitor) command 1 clock period : VEI (RTD interrupt request) command 2 clock periods : RDR (real-time RAM content output) command 3 clock periods : WRR (RAM content forcible rewrite) command or the data to rewrite 4 clock periods or more : RCV (recover from runaway) command
RTDCLK	Input	RTD transfer clock input

## 15.3 RTD Related Register

The Table below shows an RTD related register map.

### RTD Related Register Map

Address	+0 address	+1 address	See page
H'0080 077A	b0 (Use inhibited area)	b7 b8 RTD Write Function Disable Register (WRRDIS)	b15 15-3

### 15.3.1 RTD Write Function Disable Register

RTD Write Function Disable Register (WRRDIS)

<Address:H'0080 077B>

b8	9	10	11	12	13	14	b15
0	0	0	0	0	0	0	RTDWRDIS 0

<Upon exiting reset: H'00>

b	Bit Name	Function	R	W
8–14	No function assigned. Fix to "0."		0	0
15	RTDWRDIS RTD RAM write function disable bit	0: Enable RTD RAM write function 1: Disable RTD RAM write function	R	W

This register selects whether to enable or disable the RTD function for writing to RAM.

Setting the RTDWRDIS bit to "1" disables the RTD function for writing to RAM, so that even when the RTD receives a command for write to RAM, the command is ignored and no data is written to RAM.

Note: • Settings of this register cannot be altered while the RTD is in use.

### 15.4 Functional Description of the RTD

#### 15.4.1 Outline of the RTD Operation

Operation of the RTD is specified by a command entered from devices external to the chip. A command is indicated by bits 16–19 (Note 1) of the RTD received data.

**Table 15.4.1 RTD Commands**

RTD Received Data				Command	
b19	b18	b17	b16	Mnemonic	RTD Function
0	0	0	0	VER (VERify)	Continuous monitor
0	1	0	0		
0	1	0	1		
0	1	1	0	VEI (VERify Interrupt request)	RTD interrupt request
0	0	1	0	RDR (ReaD RAM)	Real-time RAM content output
0	0	1	1	WRR (WRite RAM)	RAM content forcible rewrite (with verify)
1	1	1	1	RCV (ReCoVer)	Recover from runaway condition (Note 2), (Note 3)
0	0	0	1	System reserved (use inhibited)	

↑ (Note 1)

Note 1: The RTD received data bit 19 actually is not stored in the command register, and except for the RCV command, handled as a “Don’t care” bit. (Bits 16–18 are effective for the command specified.)

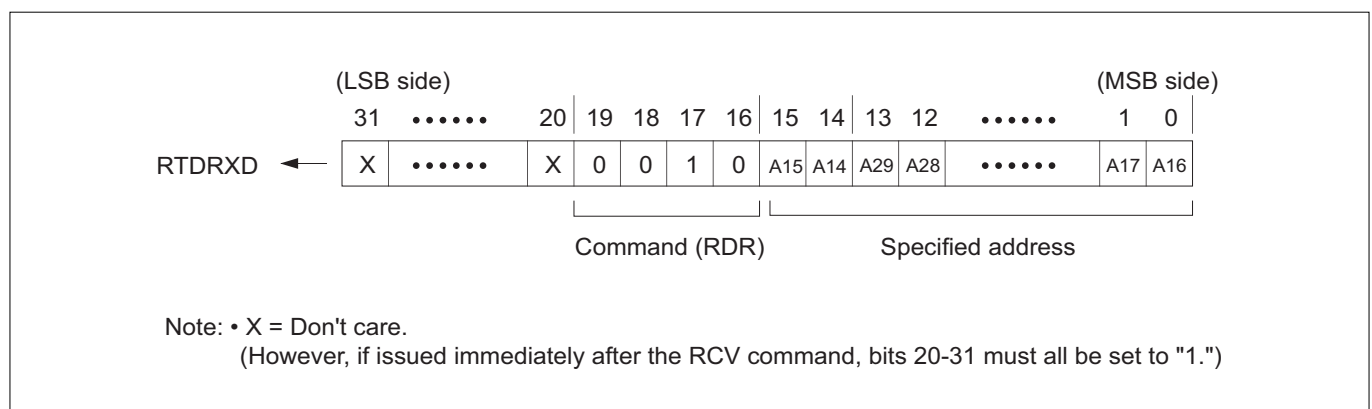
Note 2: The RCV command must always be transmitted twice in succession.

Note 3: For the RCV command, all bits, not just 16–19, (i.e., bits 0–15 and bits 20–31) must be set to “1.”

#### 15.4.2 Operation of RDR (Real-time RAM Content Output)

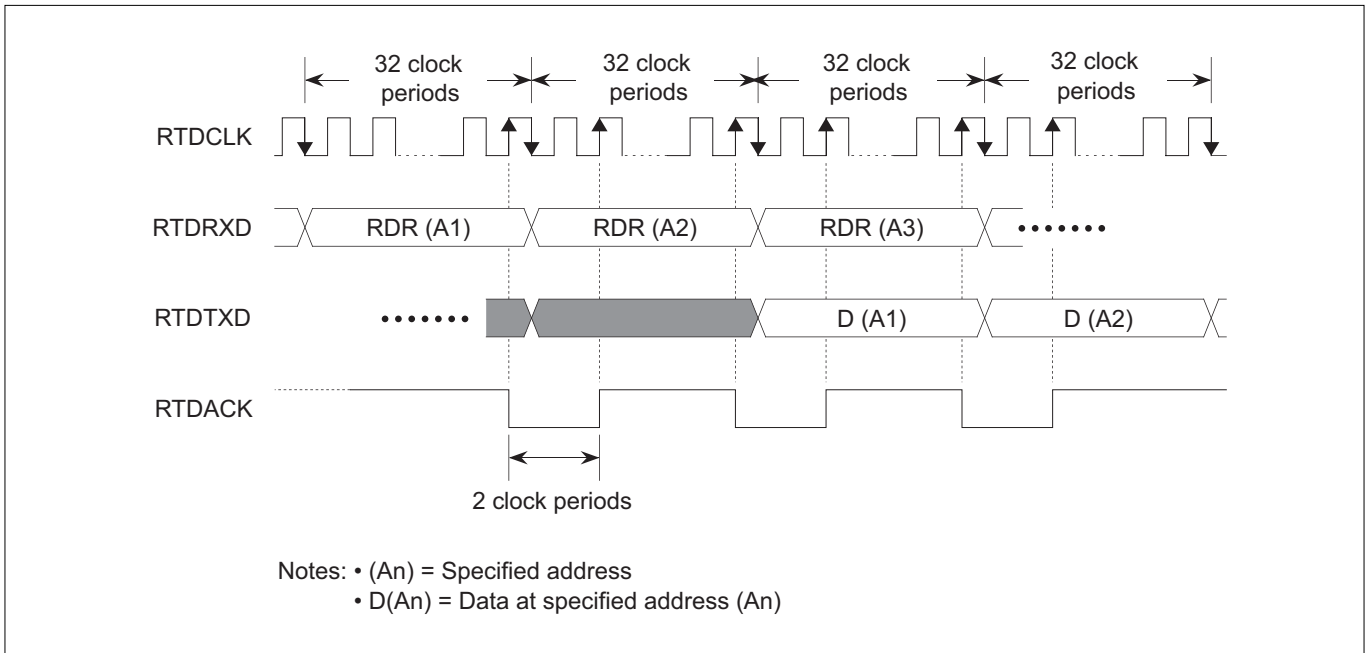
When the RDR (real-time RAM content output) command is issued, the RTD is enabled to transfer the contents of the internal RAM to external devices without causing the CPU’s internal bus to stop. Because the RTD reads data from the internal RAM while there are no transfers performed between the CPU and internal RAM, no extra CPU load is incurred.

Only the 32-bit word-aligned addresses (low-order address B'00) can be specified for read from the internal RAM. (The two low-order address bits specified by a command are ignored.) Data are read out and transferred from the internal RAM in 32-bit units.

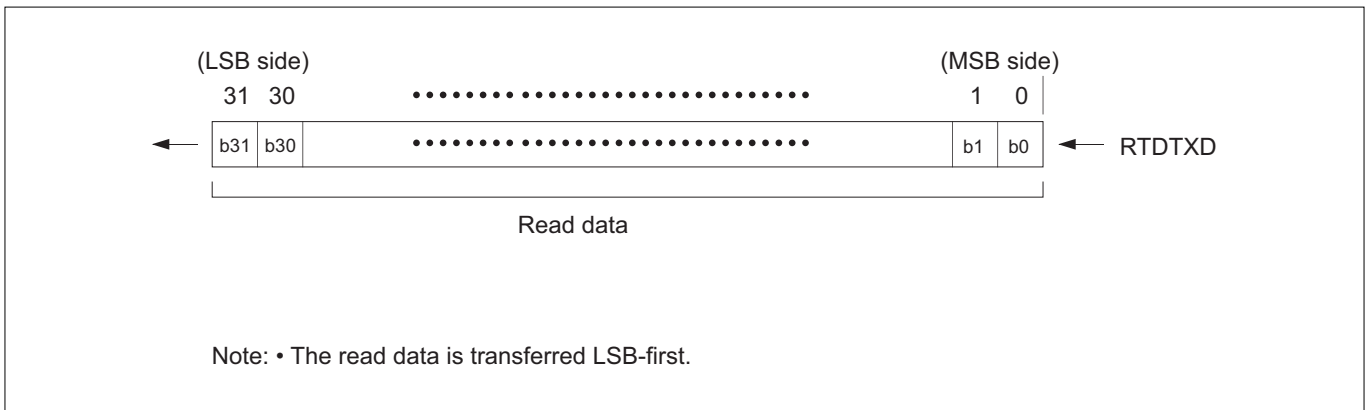


**Figure 15.4.1 RDR Command Data Format**





**Figure 15.4.2 Operation of the RDR Command**



**Figure 15.4.3 Read Data Transfer Format**

### 15.4.3 Operation of the WRR (RAM Content Forcible Rewrite)

When the WRR (RAM content forcible rewrite) command is issued, the RTD forcibly rewrites the contents of the internal RAM without causing the CPU's internal bus to stop. Because the RTD writes data to the internal RAM while there are no transfers performed between the CPU and internal RAM, no extra CPU load is incurred.

Only the 32-bit word-aligned addresses (low-order address B'00) can be specified for read from the internal RAM. (The two low-order address bits specified by a command are ignored.) Data are written to the internal RAM in 32-bit units.

The external host should transmit the command and address in the first frame and then the write data in the second frame. The RTD writes to the internal RAM in the third frame after receiving the write data.

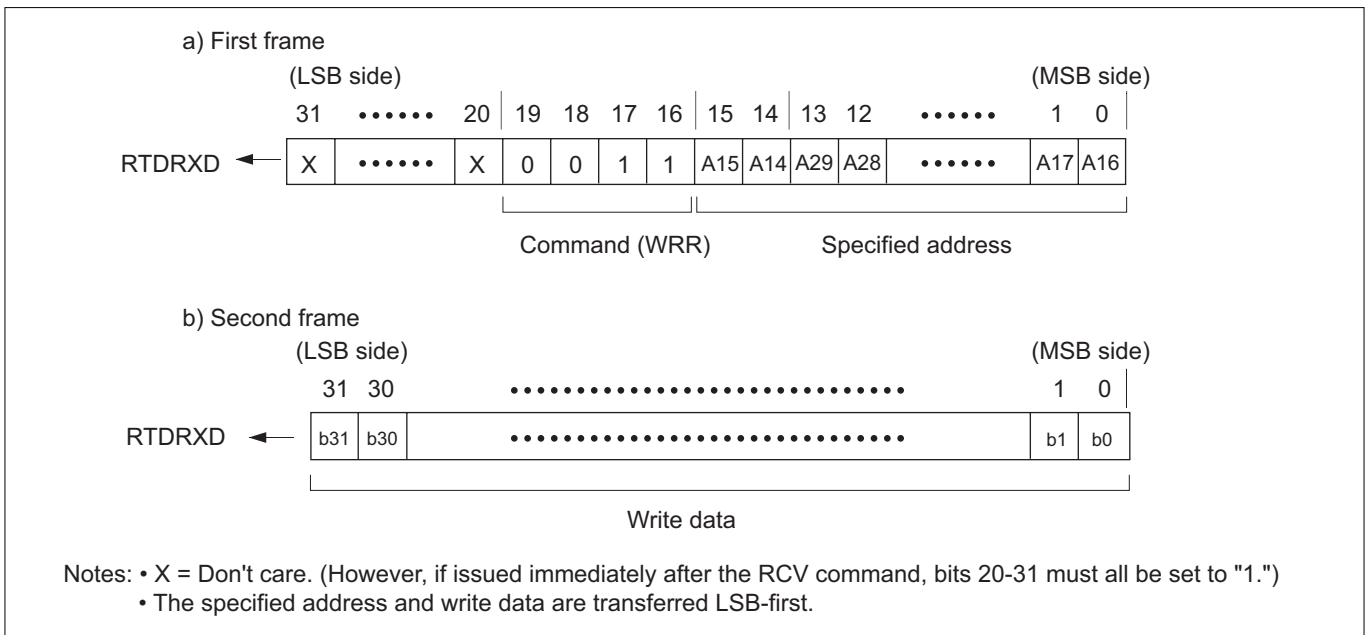


Figure 15.4.4 WRR Command Data Format

The RTD reads out data from the specified address before writing to the internal RAM and again reads out data from the same address immediately after writing to the internal RAM (this helps to verify the data written to the internal RAM). The read data is output at the timing shown below.

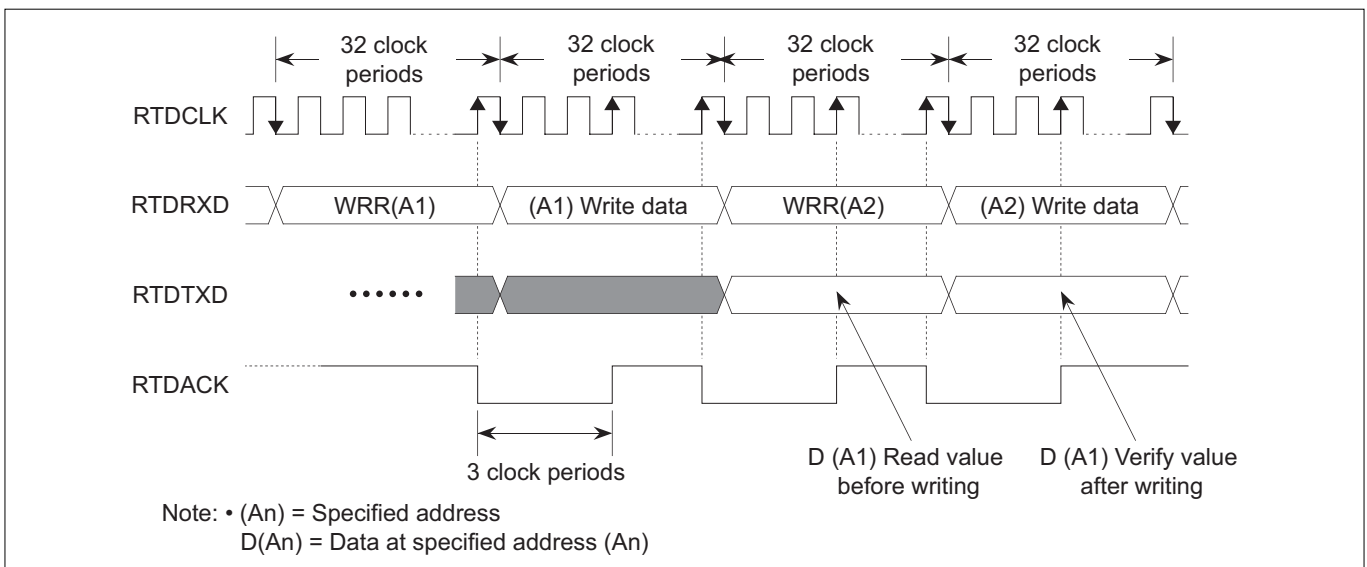


Figure 15.4.5 Operation of the WRR Command

### 15.4.4 Operation of VER (Continuous Monitor)

When the VER (continuous monitor) command is issued, the RTD outputs the data from the address that has been accessed by an instruction (either read or write) immediately before receiving the VER command.

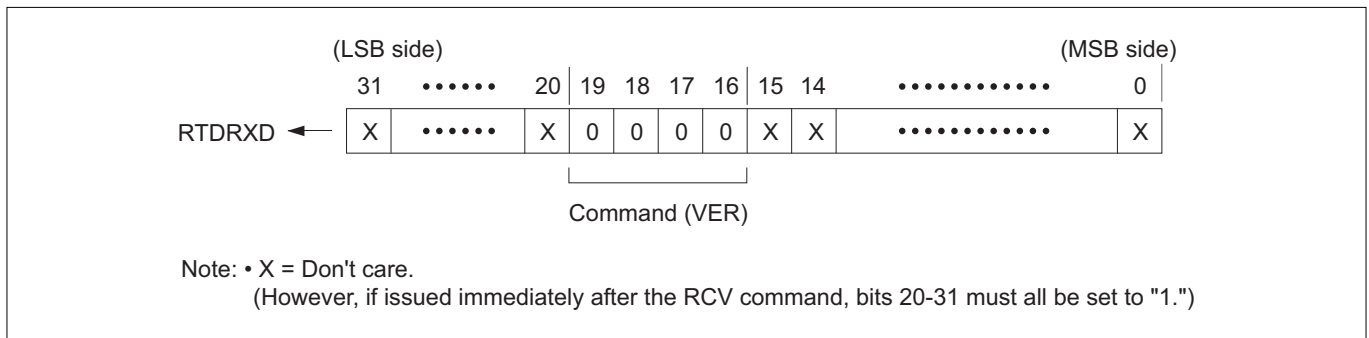


Figure 15.4.6 VER (Continuous Monitor) Command Data Format

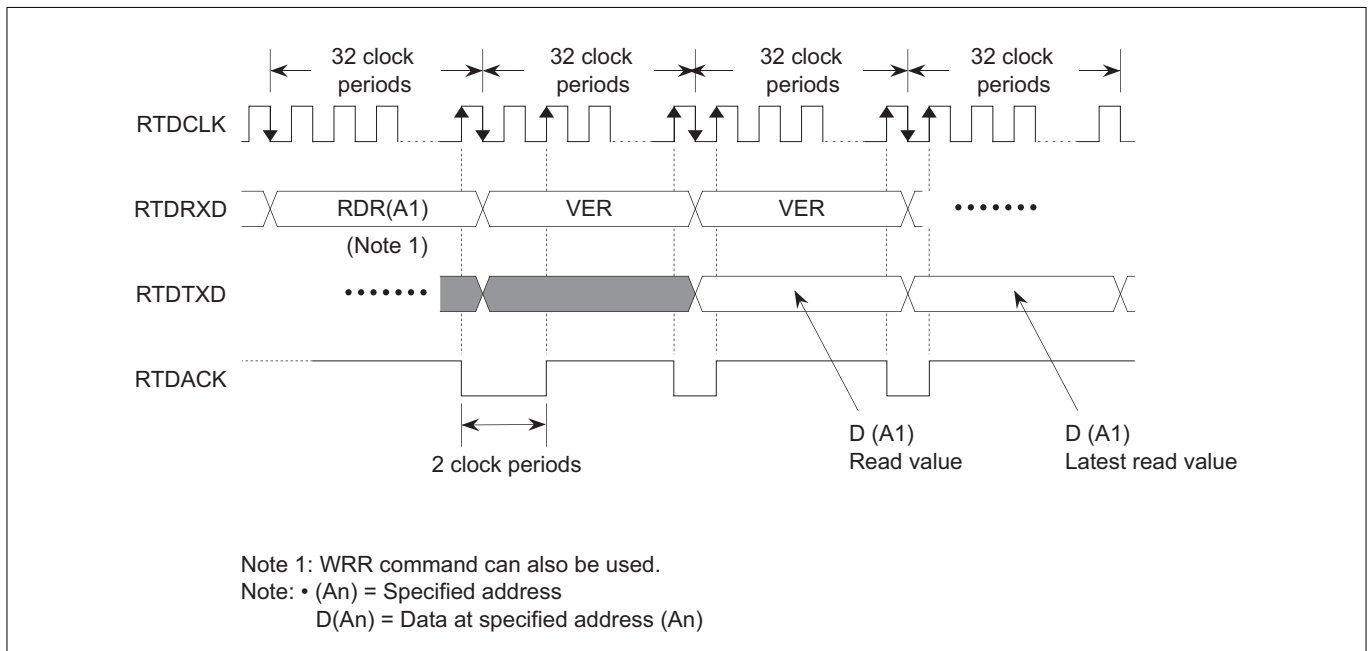


Figure 15.4.7 Operation of the VER (Continuous Monitor) Command

### 15.4.5 Operation of VEI (Interrupt Request)

When the VEI (interrupt request) command is issued, the RTD generates an interrupt request. Furthermore, the RTD outputs the data from the address that has been accessed by an instruction (either read or write) immediately before receiving the VEI command.

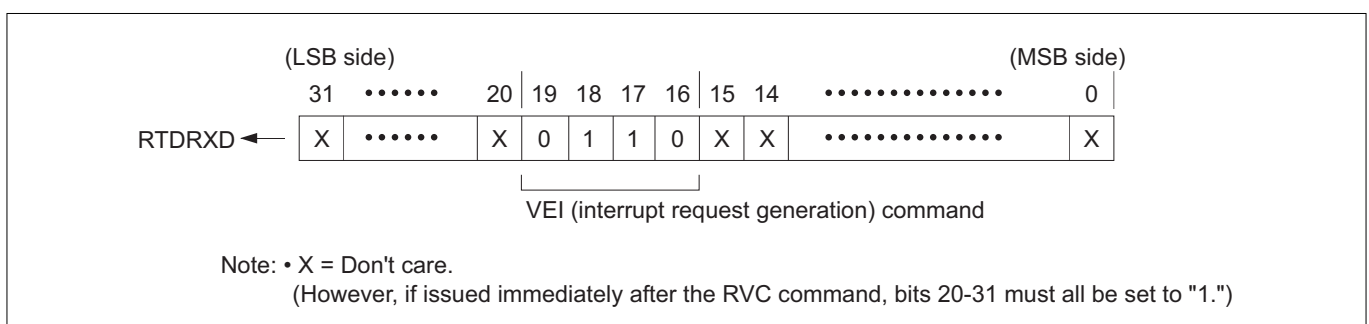


Figure 15.4.8 VEI (Interrupt Request) Command Data Format

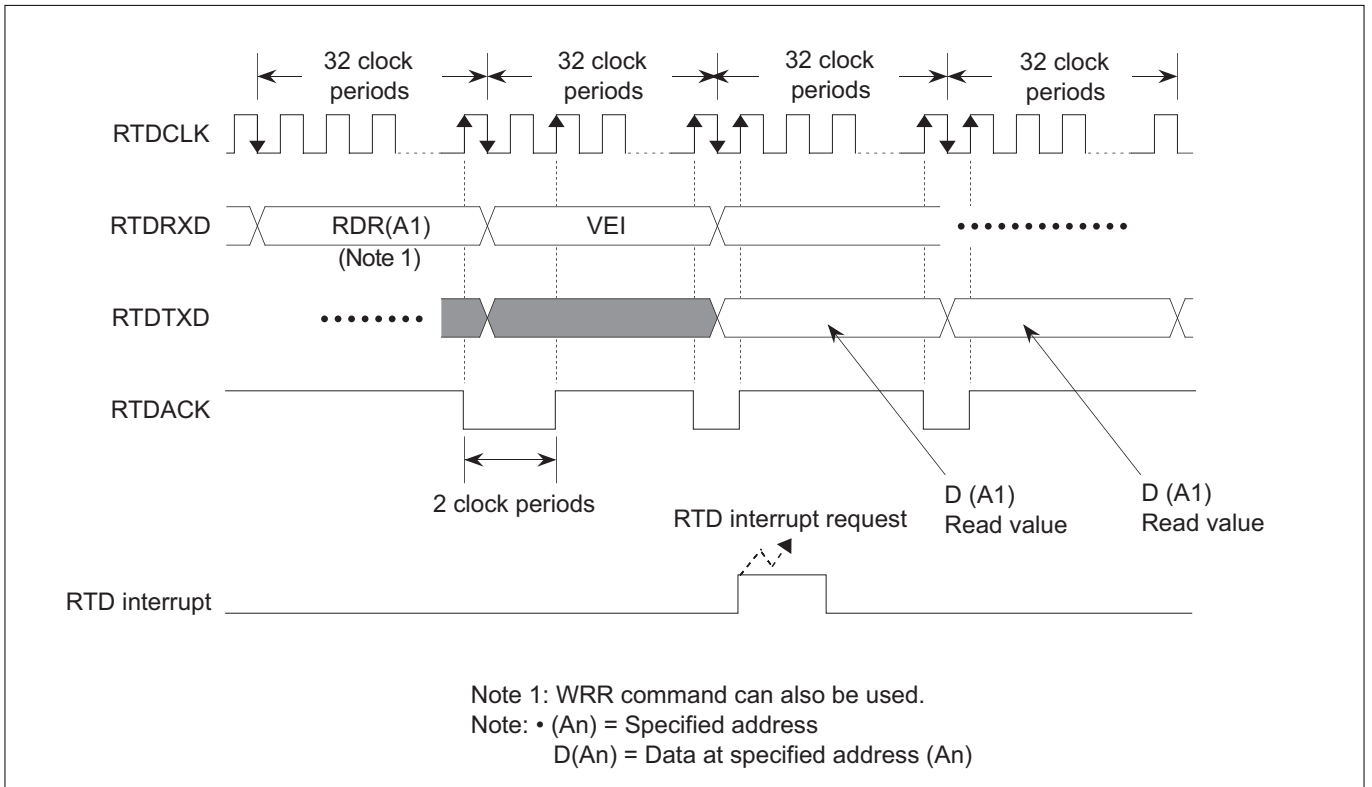


Figure 15.4.9 Operation of the VEI (Interrupt Request) Command

15.4.6 Operation of RCV (Recover from Runaway)

If the RTD runs out of control, the RCV (recover from runaway) command may be issued to recover from the runaway condition without the need to reset the system. The RCV command must always be issued twice in succession. Also, any command issued immediately following the RCV command must have all of its bits 20–31 set to "1."

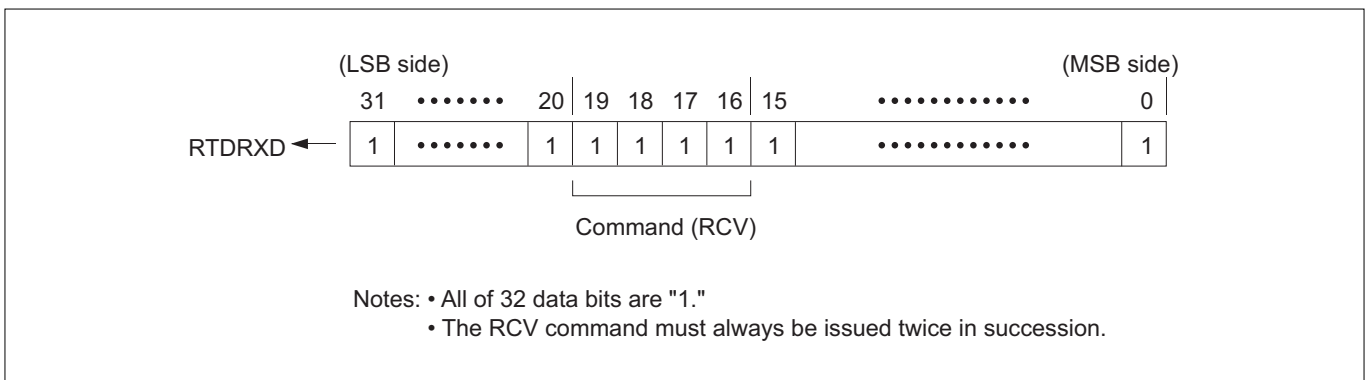
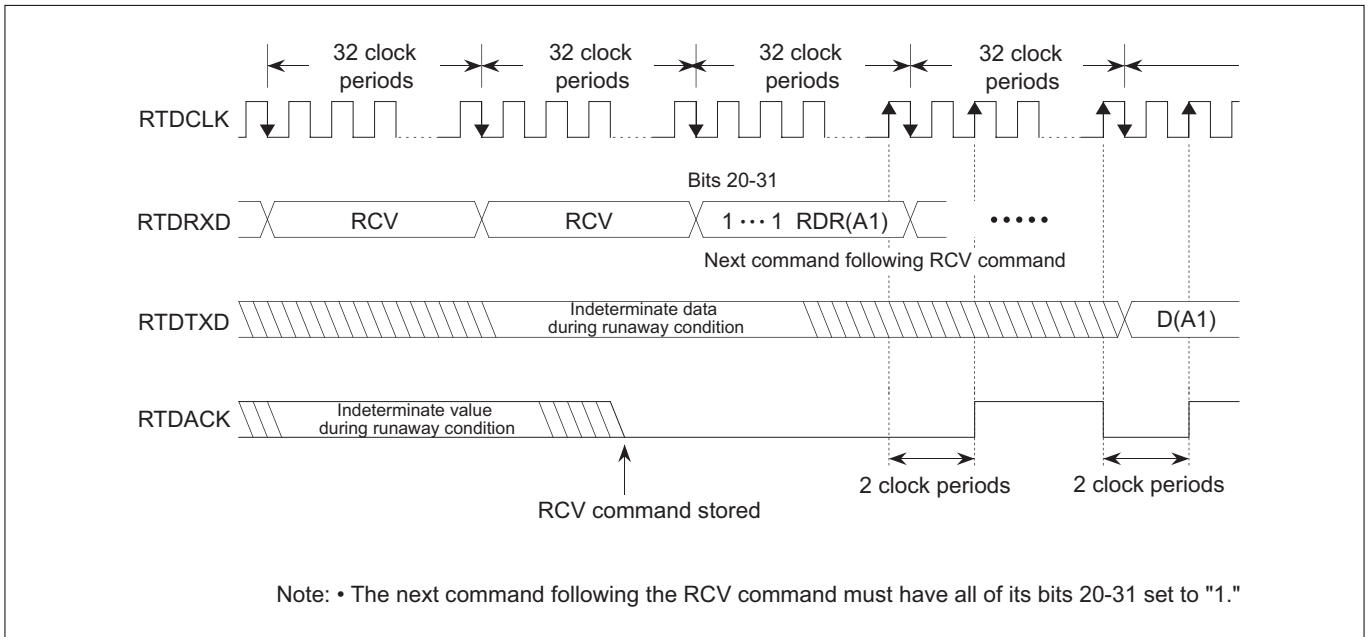


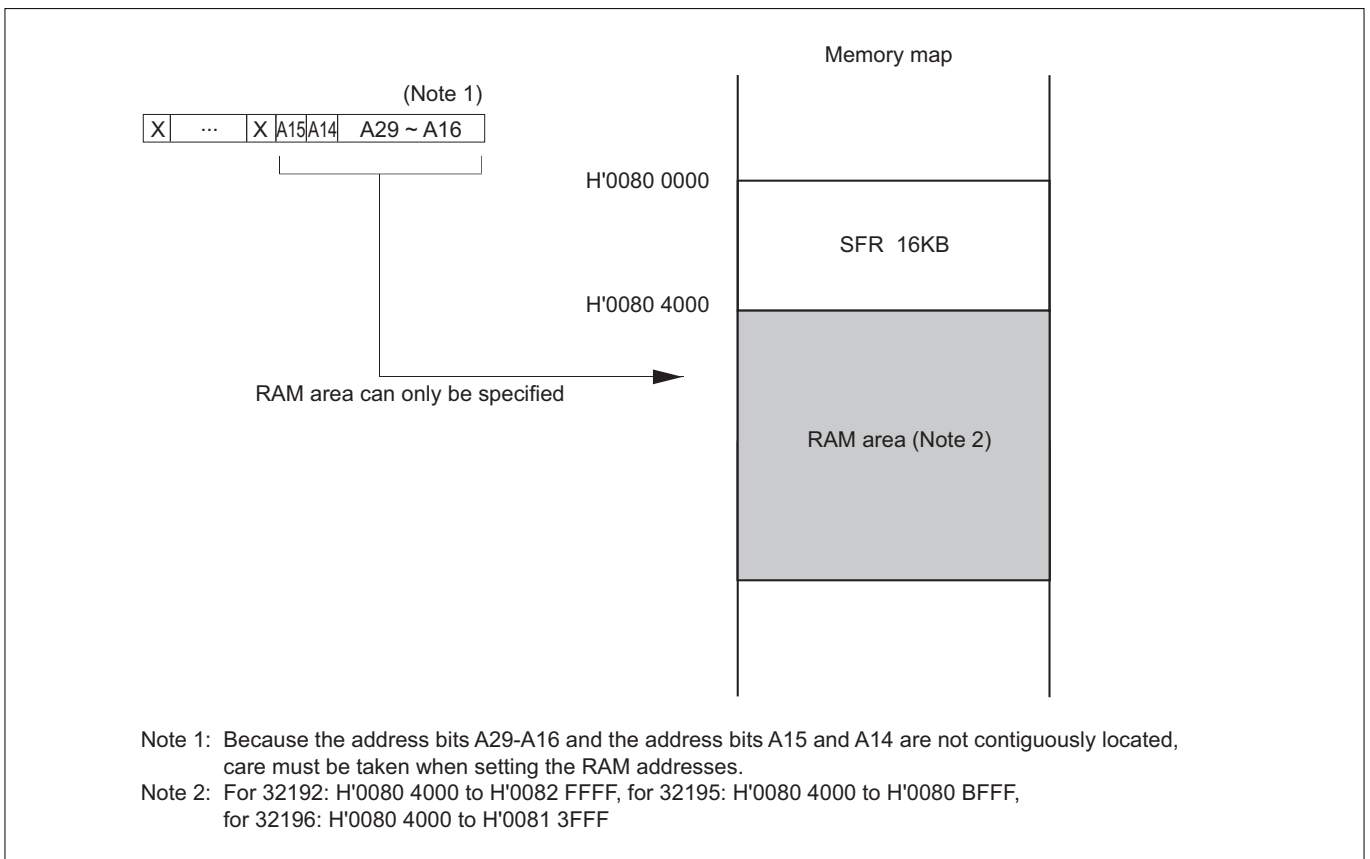
Figure 15.4.10 RCV Command Data Format



**Figure 15.4.11 Operation of the RCV Command**

### 15.4.7 Method for Setting a Specified Address when Using the RTD

In the Real-Time Debugger (RTD), the low-order 18-bit addresses of the internal RAM(H'0 0000 to H'3 FFFF) can be specified. However, it is inhibited to access any location other than the area in which the RAM is located (for 32192: H'0080 4000 to H'0082 FFFF, for 32195: H'0080 4000 to H'0080 BFFF, for 32196: H'0080 4000 to H'0081 3FFF). Note also that two least significant address bits, A31 and A30, are always "0" because data are read and written to and from the internal RAM in a fixed length of 32 bits.



**Figure 15.4.12 Setting Addresses in the Real-Time Debugger**

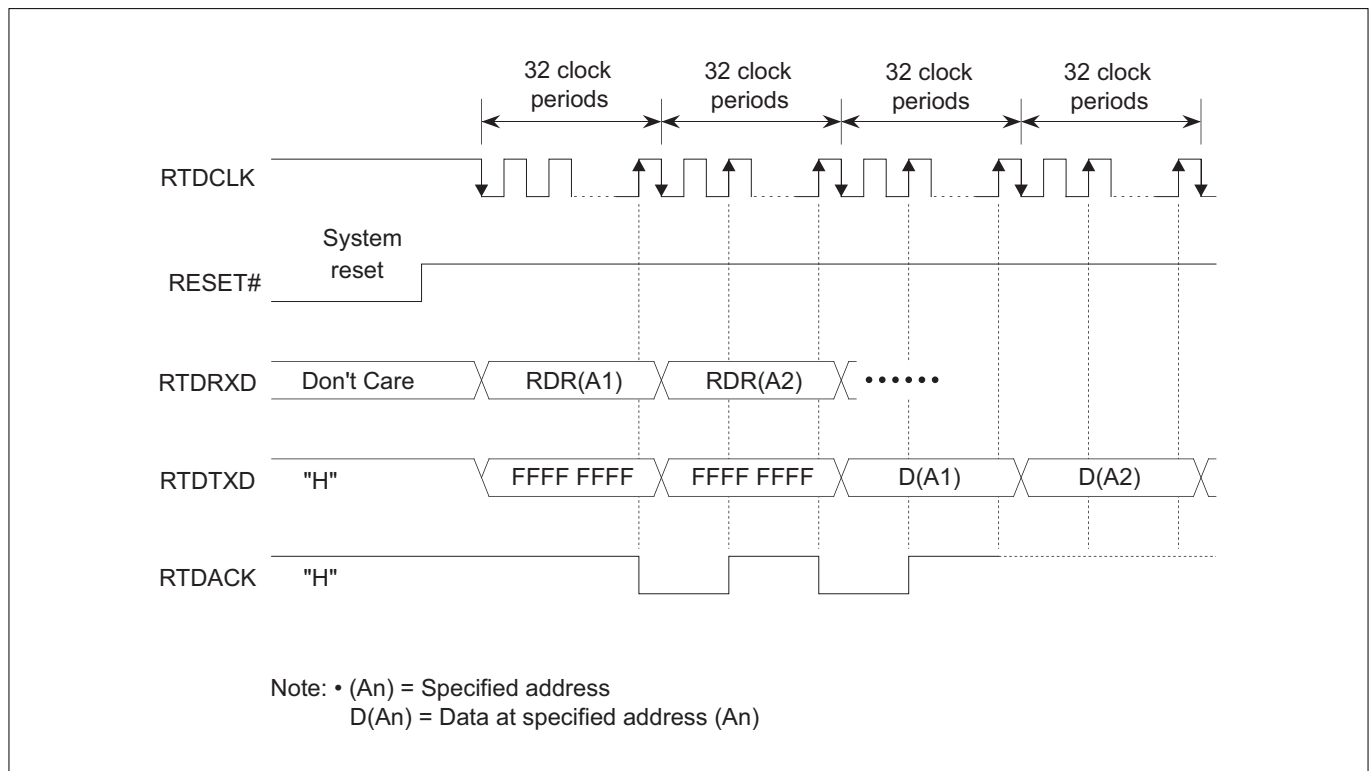
### 15.4.8 Resetting the RTD

The RTD is reset by applying a system reset (i.e., RESET# signal input). The status of the RTD related output pins upon exiting system reset are shown below.

**Table 15.4.2 RTD Pin Status Upon Exiting System Reset**

Pin Name	Status
RTDACK	"H" level output
RTDXTD	"H" level output

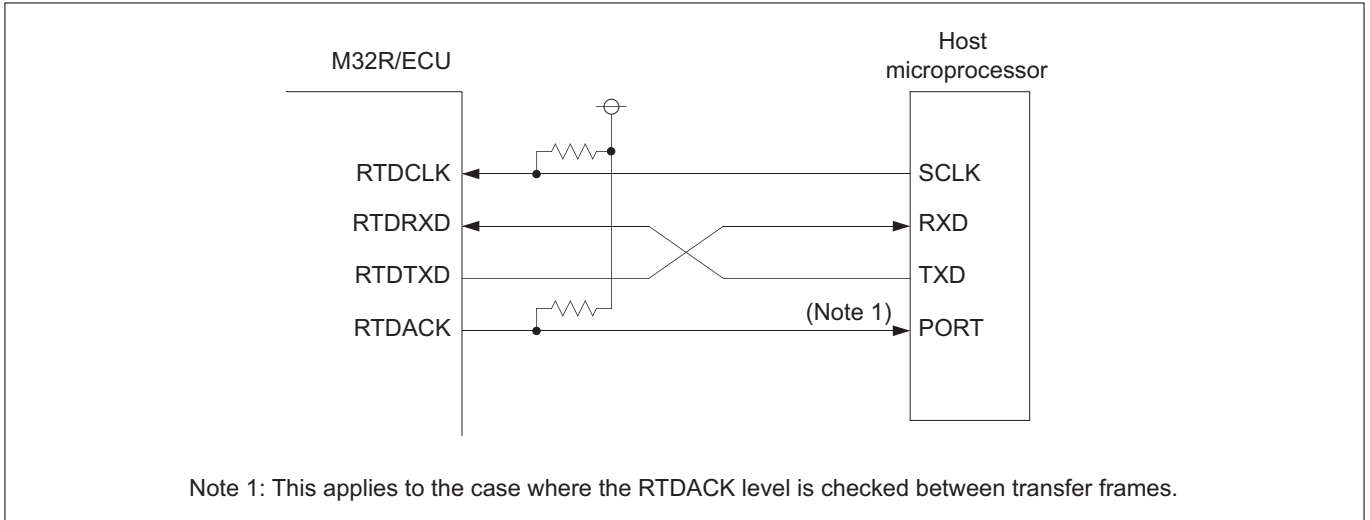
The first command transfer to the RTD after being reset is initiated by transferring data to the RTDRXD pin synchronously with the falling edge of RTDCLK.



**Figure 15.4.13 Command Transfer to the RTD after System Reset**

### 15.5 Typical Connection with the Host

The host uses a serial synchronous interface to transfer data. The clock for synchronous communication should be generated by the host. An example for connecting the RTD and host is shown below.

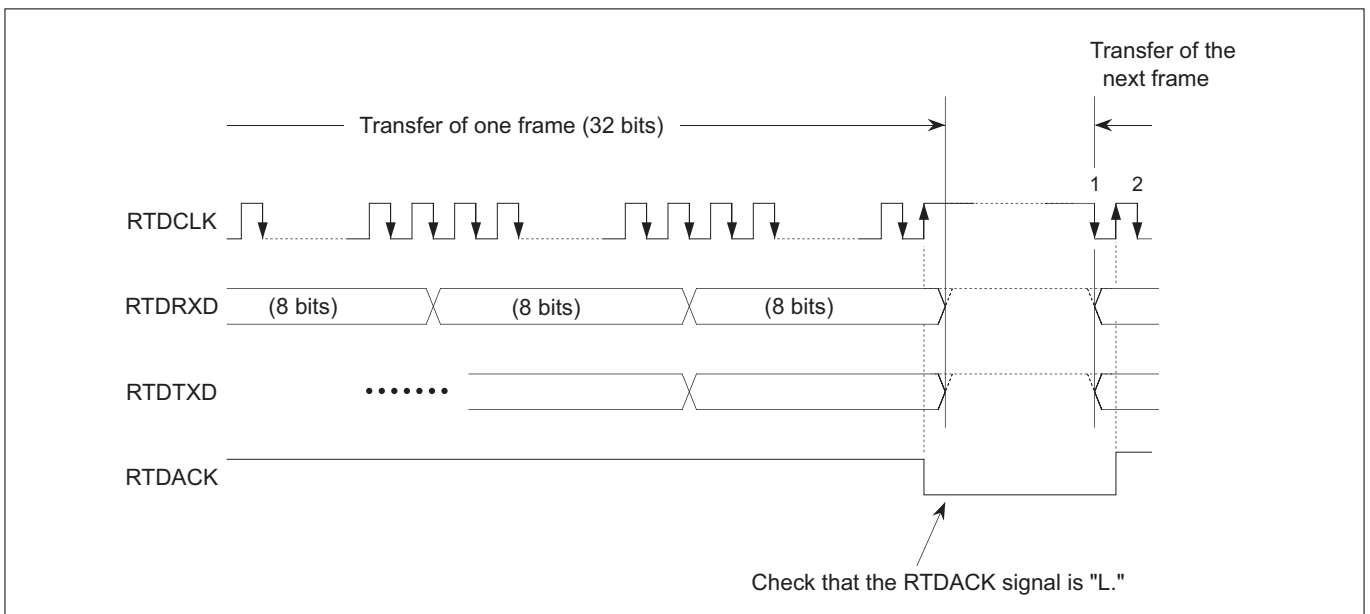


**Figure 15.5.1 Connecting the RTD and Host**

The RTD communication is performed in a fixed length of 32 bits per frame. Because serial interfaces generally handle data in 8-bit units, data is transferred separately in four operations, 8 bits at a time. The RTDACK signal is used to verify that communication is performed normally.

The RTDACK signal goes "L" after a command is sent, providing a means of verifying the communication status. When issuing the VER command, the RTDACK signal is pulled "L" for only one clock period. Therefore, after sending 32 bits in one frame via a serial interface, turn off RTDCLK output and check that RTDACK is "L." That way, it is possible to know whether the RTD is communicating normally.

If it is desirable to identify the type of transmitted command by the width of RTDACK, use the microcomputer's internal measurement timer (to count RTDCLK pulses while RTDACK is "L"), or design a dedicated circuit.



**Figure 15.5.2 Example of Communication with the Host (when Using VER Command)**

This page is blank for reasons of layout.



## **CHAPTER 16**

---

# **NON-BREAK DEBUG (NBD)**

- 16.1 Outline of the Non-Break Debug (NBD)
- 16.2 Pin Functions of NBD
- 16.3 NBD Related Registers
- 16.4 Communication Protocol
- 16.5 RAM Monitor Function
- 16.6 Event Detection Function

## 16.1 Outline of the Non-Break Debug (NBD)

Non-Break Debug (NBD) has the RAM monitor and event output functions. A dedicated DMA is incorporated in NBD, so that accesses to the internal RAM, etc. are accomplished using this DMA.

### (1) RAM monitor function

This function is provided for reading and writing to and from all resources connected to the internal/external buses mapped in the address space. It allows the RAM data, etc. to be referenced and altered. Furthermore, accesses to the address space used exclusively for NBD (i.e., NBD space) are accomplished using this function.

### (2) Event output function

Upon detecting access to a preset address, this function outputs a "L" level signal from the NBDEVNT# pin. A specific address and read/write access can be specified as the event occurrence condition.

**Table 16.1.1 Outline of the Non-Break Debug (NBD)**

Item	Content
Transfer method	Clock-synchronous parallel interface (4 bits)
Transfer clock generation	Generated by external host
Access area	All areas in the address map and NBD space
Access size	8, 16 or 32 bits (for NBD space, fixed to 8 bits)
Maximum transfer rate	12.5MHz
Input/output pins	7 pins (NBDD3–NBDD0, NBDCLK, NBDSYNC#, NBDEVNT#)
Functions	<ul style="list-style-type: none"> <li>• RAM monitor function (Note 1)</li> <li>• Event output function</li> </ul>
Number of events set	1 event

Note 1: Accessible to all resources connected to the internal/external buses as well as RAM.

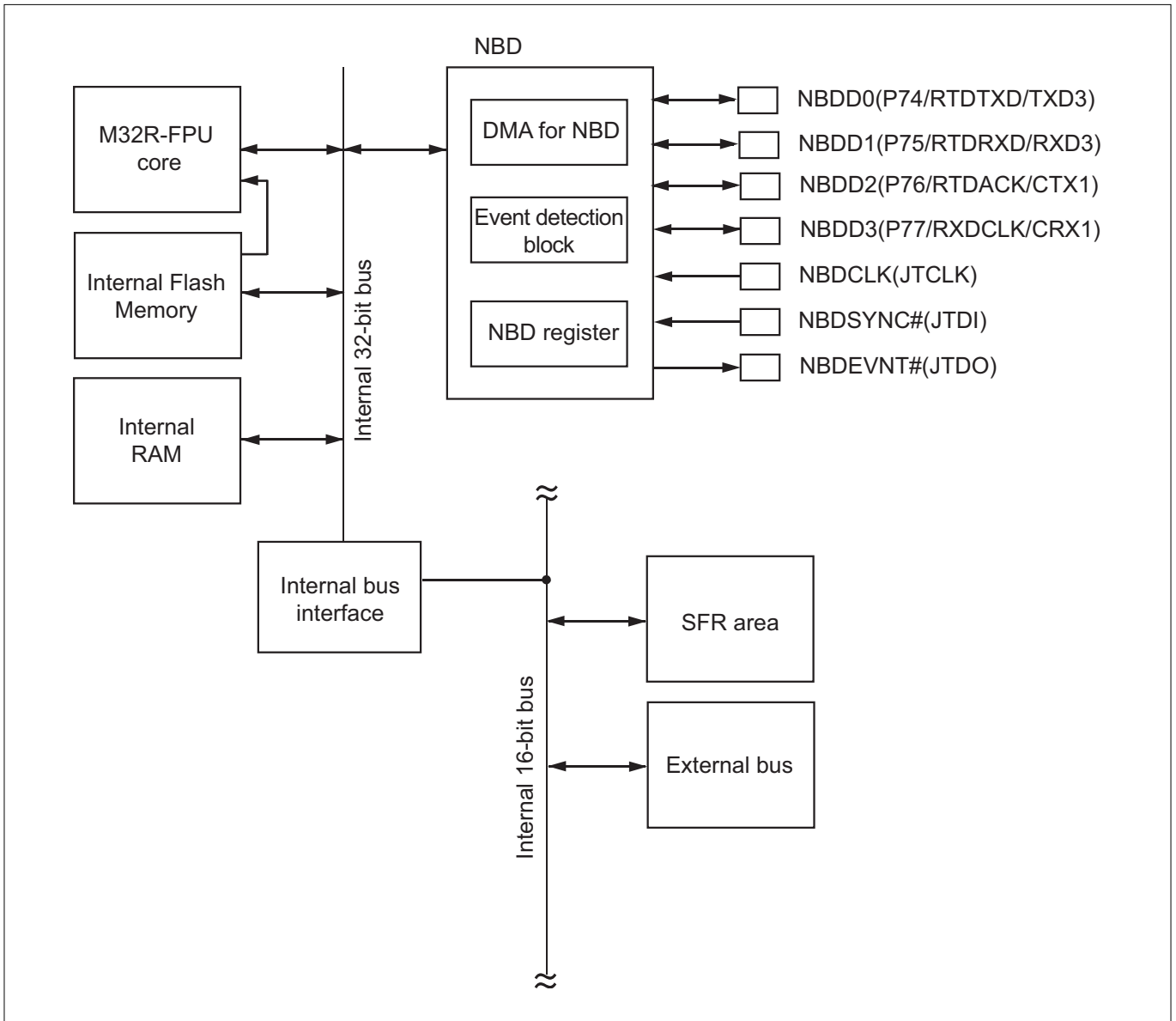


Figure 16.1.1 Block Diagram of the Non-Break Debug (NBD)

## 16.2 Pin Functions of NBD

The following describes pin functions of NBD.

**Table 16.2.1 NBD Pin Functions**

Pin name	Type	Function
NBDD3–NBDD0	Input/output	Command and address/data input/output
NBDCLK	Input	Synchronous clock input
NBDSYNC#	Input	Top of data position recognition signal input
NBDEVT#	Output	Event output (asserted "L" for 2BCLKs when an event occurs)

Note: • The NBD pins are shared with RTD, JTAG and other function. Before NBD can be used, the functions of the NBD pins must be set using the NBD Pin Control Register (NBDCNT).

### 16.2.1 NBD Pin Control Register

NBD Pin Control Register (NBDCNT)

<Address: H'E000 0004>

b0	1	2	3	4	5	6	b7
0	0	0	0	0	0	NBDSETP 0	NBDSET 0

<Upon exiting reset: H'00>

b	Bit Name	Function	R	W
0–5	No function assigned. Fix to "0."		0	0
6	NBDSETP	NBDSET write control bit	0	W
7	NBDSET	0: Set NBD-related pins for other than the NBD function NBD-related pins select bit 1: Set NBD-related pins for the NBD function	R	W

Note: • The NBD function cannot be used while the system is reset (because NBDSET = 0). For the NBD function to be used, the JTRST (JTAG reset) pin should be pulled "L."

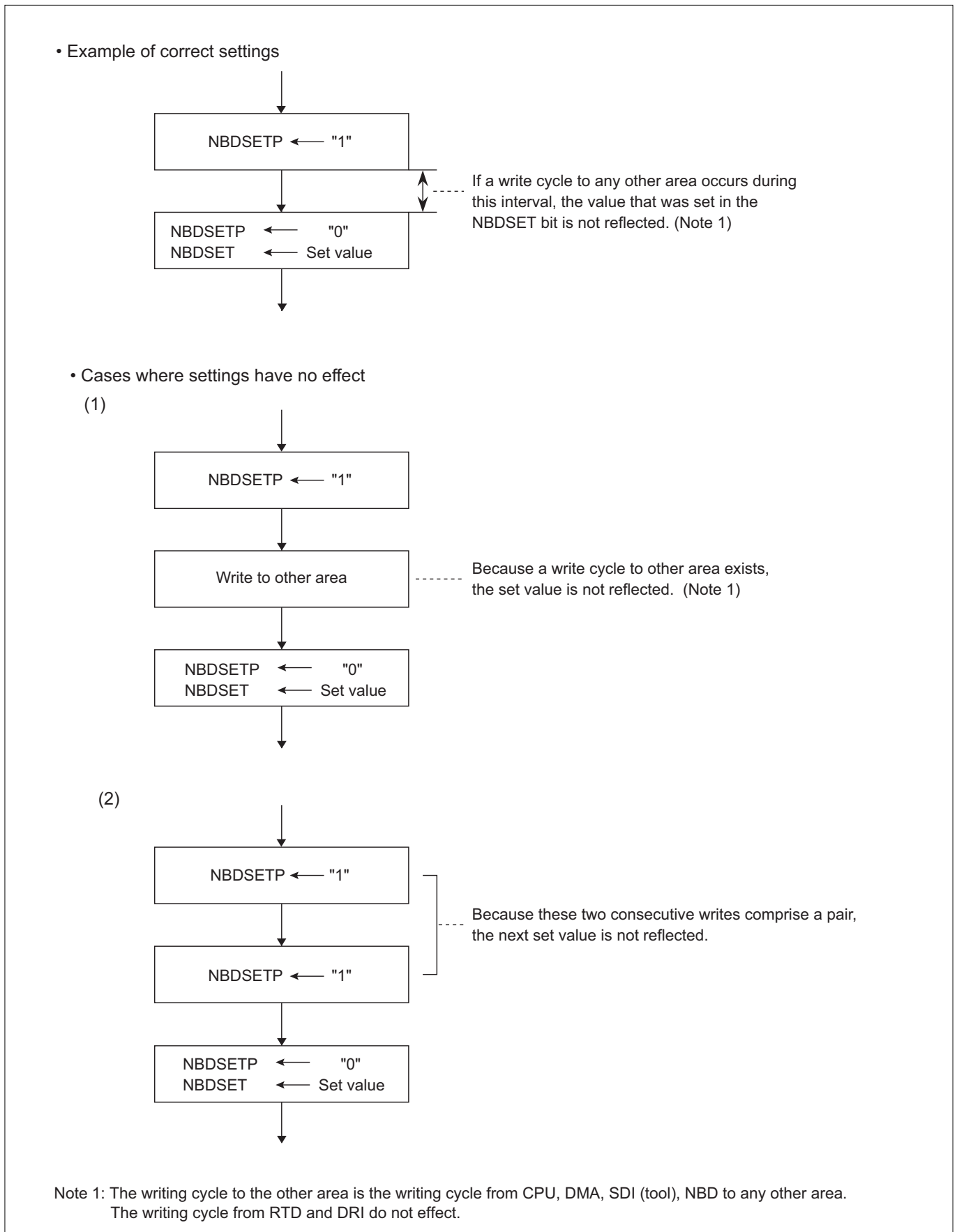
The NBDSET bit selects the functions of the NBD-related pins. To use the NBD function, set this bit to "1," so that the NBD-related pins will be set for the NBD pin functions shown in Table 16.2.1.

To set the register, follow the procedure described below.

1. Write a "1" to NBDSETP bit.
2. Subsequent to 1 above, write a "0" to NBDSETP bit and a "0" or "1" to NBDSET bit.

Notes: • If there are writing cycles from CPU, DMA, SDI (tool), NBD to any other area between 1 and 2, the continuous setting (A pair of two consecutive is 1 set for writing operation) is disabled and the writing value is not reflected. Therefore, disable interrupts and DMA transfers before setting. However the writing cycle from RTD and DRI are not effected.

- In NBDCNT register, undefined value is outputted until EVTU\_A register and EVTU\_C register are set after exiting reset, when set NBD related pin to NBD function.



**Figure 16.2.1 NBDSET Bit Setting Procedure**

## 16.3 NBD Related Registers

The following shows an NBD related register map. Some NBD-related registers are located in the address map (CPU space), and others are located in another area that is used exclusively for NBD (i.e., NBD space). The NBD space is addressed by 12 bits, and is accessed in a fixed size of 8 bits. Furthermore, the NBD space is constructed to be accessible from only the dedicated NBD interface, and cannot be accessed from the CPU.

**Table 16.3.1 NBD Related Register Map**

Space	Address	Register Name	R/W	Upon exiting reset
CPU	H'E000 0000	NBD enable register (NBDENB)	R/W	H'00
	H'E000 0004	NBD pin control register (NBDCNT)	R/W	H'00
	H'E000 0008	Event generation register (NEVNTGEN)	W	Undefined
NBD	H'800	Event address setting register (EVTU_A)	R/W	Undefined
	H'801			
	H'802			
	H'803			
	H'820	Event condition setting register (EVTU_C)	R/W	Undefined

### 16.3.1 NBD Enable Register

NBD Enable Register (NBDENB)

<Address: H'E000 0000>

b0	1	2	3	4	5	6	b7
0	0	0	0	0	0	NBDENP 0	NBDEN 0

<Upon exiting reset: H'00>

b	Bit Name	Function	R	W
0–5	No function assigned. Fix to "0."		0	0
6	NBDENP NBDEN write control bit		0	W
7	NBDEN NBD operation enable bit	0: Disable NBD operation 1: Enable NBD operation	R	W

Notes: • Allow for an interval time of 20 CPUCLK cycles or more before altering the value of the NBDEN bit.

- If the NBDEN bit is reenabled after being disabled, a finite time of 20 CPUCLK cycles is required before the NBD becomes operational.
- The value of the NBDEN bit can only be altered when the NBDSET bit in the NBD Pin Control Register = "0" (NBD-related pins set for other than the NBD function).

The NBDEN bit selects to enable or disable the NBD functions. When NBDEN = "0," the NBD is in a reset state, so that the content of each register is reset to the initial value. To use the NBD functions, this bit should be set to "1" before setting other NBD registers.

When the NBDEN bit = "0," accessing not just the NBDENB register, but any other NBD registers (in either the CPU or the NBD space) is prohibited.

To set the register, follow the procedure described below.

1. Write a "1" to NBDENP bit.
2. Subsequent to 1 above, write a "0" to NBDENP bit and a "0" or "1" to NBDEN bit.

- Notes: • If there are writing cycles from CPU, DMA, SDI (tool), NBD to any other area between 1 and 2, the continuous setting (A pair of two consecutive is 1 set for writing operation) is disabled and the writing value is not reflected. Therefore, disable interrupts and DMA transfers before setting. However the writing cycle from RTD and DRI are not effected.
- The setting procedure of NBDEN bit is same as that of NBDSET bit shown in Figure 16.2.1.

### 16.4 Communication Protocol

When NBDSYNC# is asserted, the NBD starts latching NBDD3–NBDD0 into the internal circuit synchronously with NBDCLK. Make sure NBDD3–NBDD0 are input in the format shown below.

When data input from NBDD3–NBDD0 shown in Figure 16.4.1 finishes, the data bus is temporarily placed in the high-impedance (Hi-Z) state for 1 NBDCLK cycle and then data is output from NBDD3–NBDD0 synchronously with NBDCLK in the format shown in Figure 16.4.2.

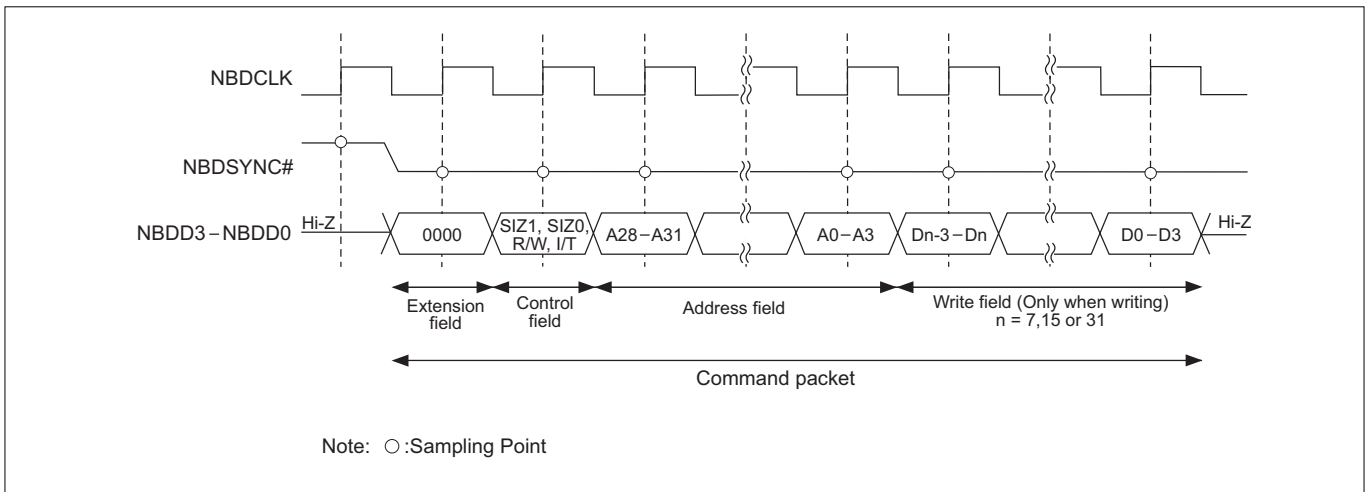


Figure 16.4.1 NBDD3–NBDD0 Input Format

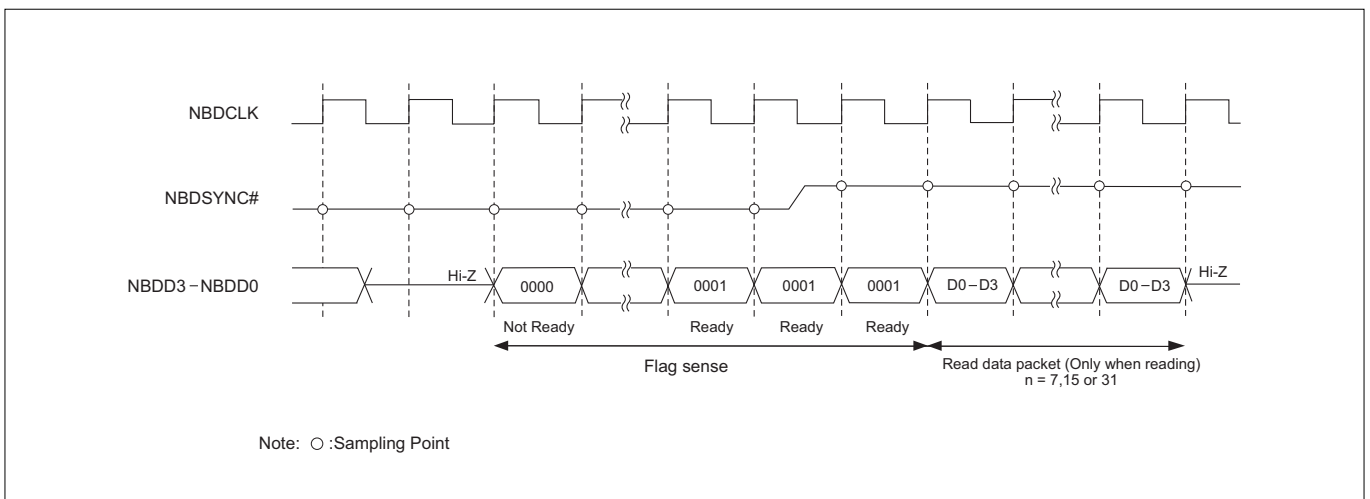


Figure 16.4.2 NBDD3–NBDD0 Output Format

## 16.5 RAM Monitor Function

### 16.5.1 Description of NBD Operation

Figure 16.5.1 shows an example of read operation of the NBD. Figure 16.5.2 shows an example of write operation of the NBD. When input to the NBDSYNC# pin is pulled "L," the NBD starts taking in a command packet from NBDD3–NBDD0 in the format shown in Figure 16.4.1. When the command packet input finishes, the NBD starts reading/writing to or from the address specified in the address field. When the NBD finishes receiving a command packet, it starts outputting data from NBDD3–NBDD0 in the format shown in Figure 16.4.2 after the data bus is temporarily placed in the high-impedance (Hi-Z) state for 1 NBDCLK cycle. While input to the NBDSYNC# pin is held "L," NBDD3–NBDD0 are in a flag sense state, in which they output Not Ready (0000) during a read/write operation or Ready (0001) when the operation has finished.

During a read, when input to the NBDSYNC# pin is released back "H" after detecting Ready, the read data (read data packet) is output (Figure 16.5.1).

Before a next command packet can be transmitted, input to the NBDSYNC# pin must be held "H" for at least 2 NBDCLK cycles.

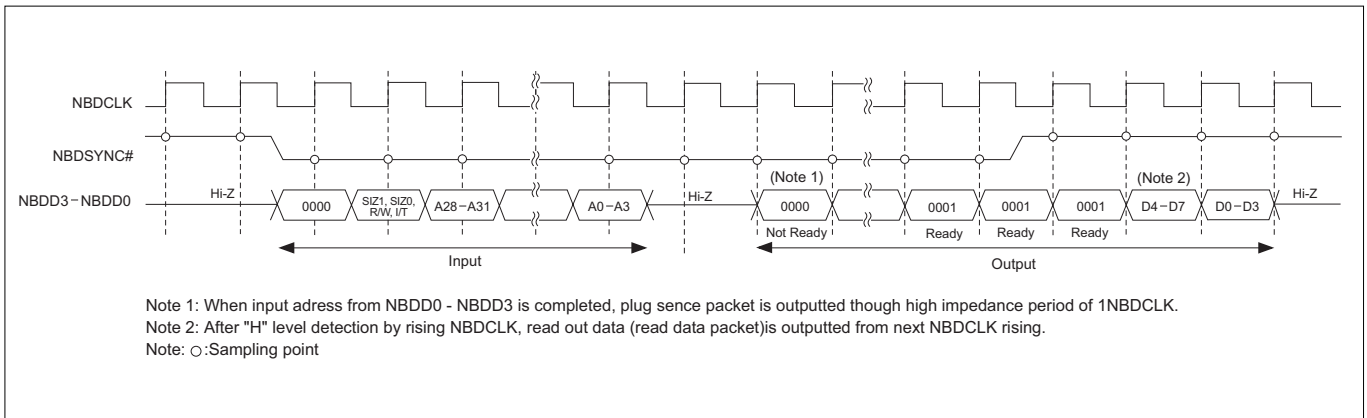


Figure 16.5.1 Example of Read Operation (for 8-Bit Read from the CPU Space)

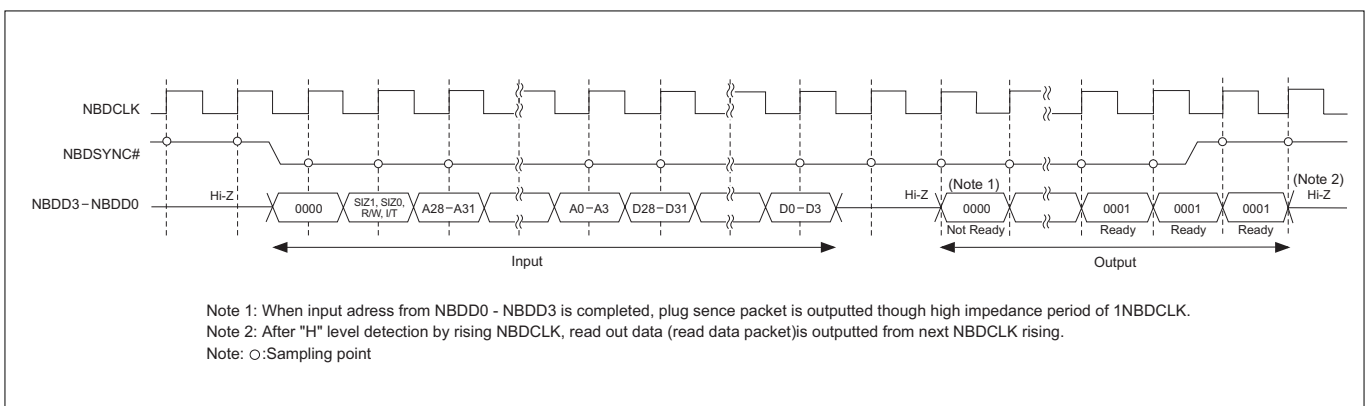


Figure 16.5.2 Example of Write Operation (for 32-Bit Write to the CPU Space)



## 16.5.2 NBDD Data Format

The following describes the content of each packet/field which are input to or output from the NBDD3–NBDD0 pins.

## (1) Command packet (input)

Table 16.5.1 Bit Assignments of a Command Packet

Input order	Field name	Bit arrangement				√: Necessary, -: Unnecessary					
		NBDD3	NBDD2	NBDD1	NBDD0	When accessing NBD space		When accessing CPU space			
						During read	During write	During read	During 8-bit write	During 16-bit write	During 32-bit write
First ↓ Last	Extension field	aux3	aux2	aux1	aux0	√	√	√	√	√	√
	Control field	SIZ1	SIZ0	R/W	I/T	√	√	√	√	√	√
	Address field	A28	A29	A30	A31	–	–	√	√	√	√
		A24	A25	A26	A27	–	–	√	√	√	√
		A20	A21	A22	A23	–	–	√	√	√	√
		A16	A17	A18	A19	–	–	√	√	√	√
		A12	A13	A14	A15	–	–	√	√	√	√
		A8	A9	A10	A11	√	√	√	√	√	√
		A4	A5	A6	A7	√	√	√	√	√	√
		A0	A1	A2	A3	√	√	√	√	√	√
	Write data field	D28	D29	D30	D31	–	–	–	–	–	√
		D24	D25	D26	D27	–	–	–	–	–	√
		D20	D21	D22	D23	–	–	–	–	–	√
		D16	D17	D18	D19	–	–	–	–	–	√
		D12	D13	D14	D15	–	–	–	–	√	√
		D8	D9	D10	D11	–	–	–	–	√	√
		D4	D5	D6	D7	–	√	–	√	√	√
		D0	D1	D2	D3	–	√	–	√	√	√

## 1) Extension field

Bit Name	Function	Content
aux3	Reserved for future extension	Set to "0"
aux2	Reserved for future extension	Set to "0"
aux1	Reserved for future extension	Set to "0"
aux0	Reserved for future extension	Set to "0"

Note 1: If these bits are set otherwise, device operation cannot be guaranteed.

## 2) Control field

Bit Name	Function	Content
SIZ1, SIZ0	Specify access size	SIZ1 SIZ0 0 0 8-bit (Note 1) 0 1 16-bit 1 0 32-bit 1 1 Settings inhibited
R/W	Specify read/write	0: Read 1: Write
I/T	Specify access space	0: Access NBD space 1: Access CPU space

Note 1: When the NBD space access is selected (I/T = "0"), only 8-bit access is accepted. If these bits are set otherwise, device operation cannot be guaranteed.

**3) Address field**

Bit Name	Function	Content
A0–A31	Specify address When accessing NBD space: specify with 12 bits of A0–A11 When accessing CPU space: specify with 32 bits of A0–A31	A0–A31 should be specified in big endian format (A0 = MSB).

**4) Write data field**

Bit Name	Function	Content
D0–D31	Specify write data	D0–D31 should be specified in big endian format (D0 = MSB). The necessary number of bits varies depending on how the R/W bit and SIZ1–SIZ0 bits in the control field are set. (See Table 16.5.1 Bit Assignments of a Command Packet)

**(2) Flag sense packet (output)****Table 16.5.2 Bit Assignments of a Flag Sense Packet**

Bit arrangement			
NBDD3	NBDD2	NBDD1	NBDD0
0	0	0	RFLG

Bit Name	Function	Content
RFLG	Indicates that the internal operation of NBD is completed	0: Not Ready 1: Ready

**(3) Read data packet (output)****Table 16.5.3 Bit Assignments of a Read Data Packet**

Output order	Bit arrangement				√: Necessary, -: Unnecessary					
	NBDD3	NBDD2	NBDD1	NBDD0	When accessing NBD space		When accessing CPU space			
					During read (Note 1)	During write	During 8-bit write	During 16-bit write	During 32-bit write	During write
First ↓ Last	D28	D29	D30	D31	-	-	-	-	√	-
	D24	D25	D26	D27	-	-	-	-	√	-
	D20	D21	D22	D23	-	-	-	-	√	-
	D16	D17	D18	D19	-	-	-	-	√	-
	D12	D13	D14	D15	-	-	-	√	√	-
	D8	D9	D10	D11	-	-	-	√	√	-
	D4	D5	D6	D7	√	-	√	√	√	-
Last	D0	D1	D2	D3	√	-	√	√	√	-

Note 1: When the NBD space access is selected, only 8-bit access is accepted.

Bit Name	Function	Content
D0–D31	Output read data	D0–D31 should be specified in big endian format (D0 = MSB). The number of bits to be output varies depending on how the R/W bit and SIZ1–SIZ0 bits in the control field are set. (See Table 16.5.3 Bit Assignments of a Read Data Packet)

### 16.6 Event Detection Function

The NBD has the function to output an event occurrence when there is a matching address accessed for read/write in the CPU space. The event output is active "L," and is asserted synchronously with BCLK for a period of 2 BCLK cycles. The NBDEVNT# pin also can output a "L" level signal for 2 BCLK cycles when the NEVNTGEN register located in the CPU space is accessed for write. Output from the NBDEVNT# pin is generated by matching the above-mentioned address or a write access to the NEVNTGEN register

Figure 16.6.1 shows the structure of the NBDEVNT# pin.

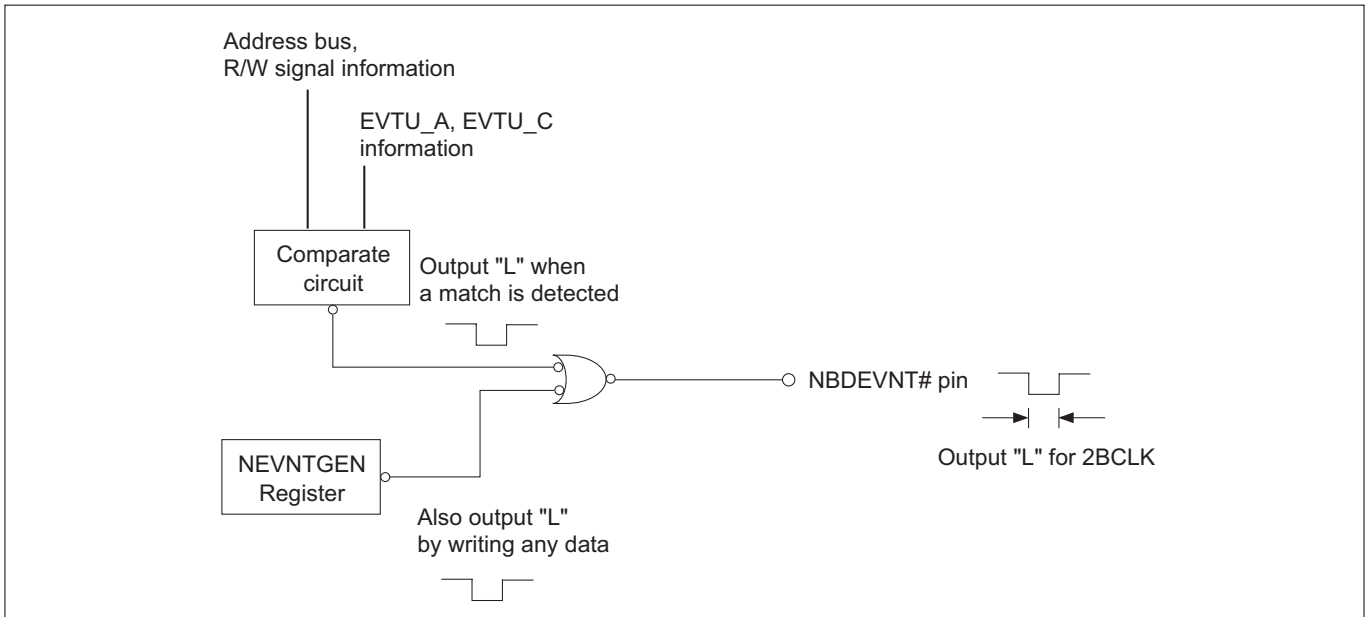


Figure 16.6.1 NBDEVNT# Pin Configuration

#### 16.6.1 Event Address Setting Register

Event Address Setting Register (EVTU\_A)

<Address: H'800–H'803 (NBD space)>

b0	1	2	3	4	5	6	7	8	9	10	11	12	13	14	b15
EVTU_A															
?	?	?	?	?	?	?	?	?	?	?	?	?	?	?	?
b16	17	18	19	20	21	22	23	24	25	26	27	28	29	30	b31
EVTU_A														0 0	
?	?	?	?	?	?	?	?	?	?	?	?	?	?	0	0

<Upon exiting reset: Undefined>

b	Bit Name	Function	R	W
0–29	EVTU_A	Specify the target address A0–A29 for event detection	R	W
30, 31	No function assigned. Fix to "0."		0	0

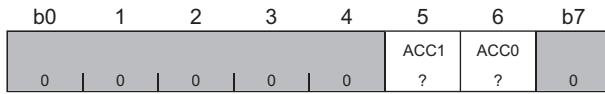
Notes: • In the NBDEN bit of NBD enable register (NBDENB), AVTU\_A bit value becomes indefinite after setting from "0" (disable NBD operation) to "1"(enable NBD operation).

- After enabling NBD operation(after setting "1" in NBDEN bit of NBDENB register), an indefinite value is outputted from NBDEVNT# pin in NBD pin control register(NBDCNT) during the period of time from setting NBD-related pins to NBD function to setting value of EVTU\_A and EVTU\_C are effective(period of time from Ready status to after 3NBDCLK).
- During event detection function is used, when the setting value of EVTU\_A register or EVTU\_C register is changed, the event detection result by the changed setting conditions becomes effective after 3NBDCLK from setting EVTU\_A register or EVTU\_C register (at the time of being Ready state in flag sense period).

#### 16.6.2 Event Condition Setting Register

Event Condition Setting Register (EVTU\_C)

<Address: H'820 (NBD space)>



<Upon exiting reset: Undefined>

b	Bit Name	Function	R	W
0-4	No function assigned. Fix to "0."		0	0
5, 6	ACC1, ACC0	Specify R/W condition for event detection	R	W
		ACC1 ACC0 Event generation condition		
		0 0 Read access		
		0 1 Write access		
		1 0 Read or write access		
		1 1 Settings inhibited		
	No function assigned. Fix to "0."		0	0

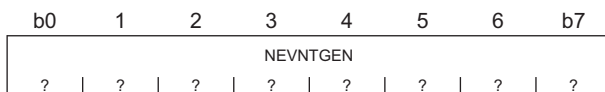
- Notes:
- In the NBDEN bit of NBD enable register (NBDENB), AVTU\_A bit value becomes indefinite after setting from "0" (disable NBD operation) to "1" (enable NBD operation).
  - After enabling NBD operation (after setting "1" in NBDEN bit of NBDENB register), an indefinite value is outputted from NBDEVENT# pin in NBD pin control register (NBDCNT) during the period of time from setting NBD-related pins to NBD function to setting value of EVTU\_A and EVTU\_C are effective (period of time from Ready status to after 3NBDCLK).
  - During event detection function is used, when the setting value of EVTU\_A register or EVTU\_C register is changed, the event detection result by the changed setting conditions becomes effective after 3NBDCLK from setting EVTU\_A register or EVTU\_C register (at the time of being Ready state in flag sense period).

For executed-PC event detection can be implemented using the Event Address set register (EVTU\_A) and the Event Condition set register (EVTU\_C), it is necessary that the target PC address be set in the EVTU\_A register and that the ACC1 and ACC0 bits of the EVTU\_C register be set to "H'00" (read access). Once these settings are made, when the EVTU\_A register address is accessed for instruction read (instruction prefetch) by the CPU, event output can be generated upon detecting this CPU access. In this case, event can also be generated for an operand access to the EVTU\_A register address by the CPU. Note that since this facility is designed to detect an event occurrence for instruction read access (instruction prefetch), events may be generated for instructions that actually are not executed.

#### 16.6.3 Event Generation Register

Event Generation Register (NEVNTGEN)

<Address: H'E000 0008>



<Upon exiting reset: Undefined (not readable)>

b	Bit Name	Function	R	W
0-7	NEVNTGEN	When any data is written to this register, a "L" level signal is output from the NBDEVENT# pin for 2 BCLK cycles. When this register is accessed for read, indeterminate data is read out.	-	W

- Note:
- If multiple events occur in close proximity in time, the "L" level signal output from the NBDEVENT# pin may only be asserted "L" for 2 BCLK cycles (i.e., for one event). Conversely, depending on event occurrence conditions, two or more 2-BCLK "L" level signals may be output in succession.

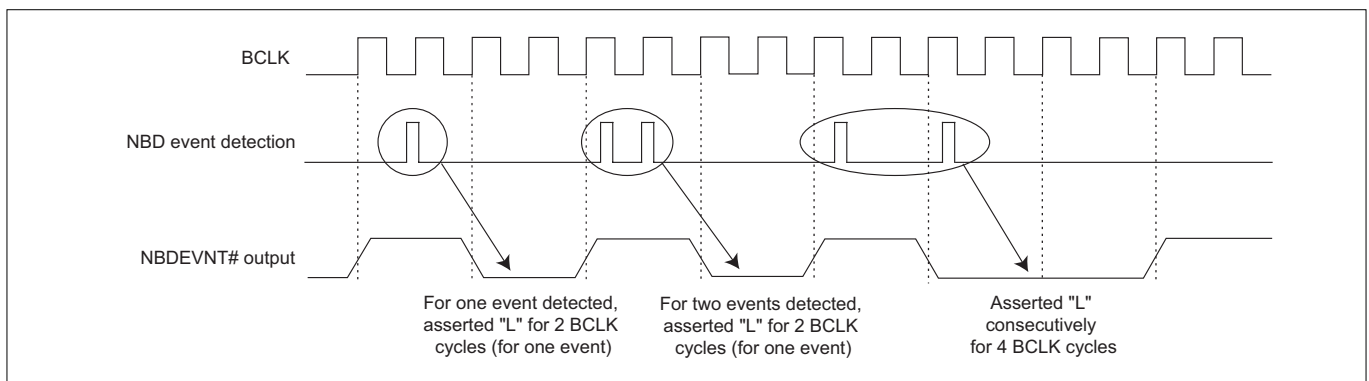


Figure 16.6.2 Relationship between NBD Event Detection and NBDEVENT# Pin Operation

## CHAPTER 17

---

# EXTERNAL BUS INTERFACE

- 17.1 Outline of the External Bus Interface
- 17.2 External Bus Interface Related Registers
- 17.3 Read/Write Operations
- 17.4 Bus Arbitration
- 17.5 Typical Connection of External Extension Memory
- 17.6 Example of Bus Voltage Settings Using VCC-BUS

## 17.1 Outline of the External Bus Interface

### 17.1.1 External Bus Interface Related Signals

The 32192/32195/32196 has the external bus interface related signals described below. These signals can be used in external extension and processor modes. Furthermore, a dedicated power supply for the bus control pins (bus power supply: VCC-BUS) is included. When used separately from other power supplies, it allows external devices operating with other than the main power supply voltage to be connected.

The symbol “#” suffixed to the signal names (or pin names) means that the signals (or pins) are active “L.”

#### (1) Address

The 32192/32195/32196 outputs a 22-bit address (A9–A30) for addressing any location in a 8-Mbyte space. The least significant A31 is not output.

Note: • During external extension mode, these pins are switched for port upon exiting reset. Their pin functions must be set for address output using the corresponding Port Operation Mode Register as necessary.

#### (2) Chip Select (CS0#–CS3#)

The CS0#–CS3# signals are output for external extension areas divided in 8-Mbyte units. The CS0# signal points to a 8-Mbyte area during processor mode or a 7-Mbyte area during external extension mode. (For details, see Chapter 3, “Address Space.”)

Note: • During external extension mode, these pins are switched for port upon exiting reset. Their pin functions must be set for chip select using the corresponding Port Operation Mode Register as necessary.

#### (3) Read Strobe (RD#)

Output during an external read cycle, this signal indicates the timing at which to read data from the bus. This signal is driven “H” when writing to the bus or accessing the internal area.

#### (4) Byte High Write/Byte High Enable (BHW#/BHE#)

The pin function changes depending on the Bus Mode Control Register (BUSMODC).

When BUSMOD = “0” and this signal is Byte High Write (BHW#), during external write access it indicates that the upper byte (DB0–DB7) of the data bus is the valid data transferred. During external read and when accessing the internal area it outputs a “H.”

When BUSMOD = “1” and this signal is Byte High Enable (BHE#), during external access (for read or write) it indicates that the upper byte (DB0–DB7) of the data bus is the valid data transferred. When accessing the internal area it outputs a “H.”

#### (5) Byte Low Write/Byte Low Enable (BLW#/BLE#)

The pin function changes depending on the Bus Mode Control Register (BUSMODC).

When BUSMOD = “0” and this signal is Byte Low Write (BLW#), during external write access it indicates that the lower byte (DB8–DB15) of the data bus is the valid data transferred. During external read and when accessing the internal area it outputs a “H.”

When BUSMOD = “1” and this signal is Byte Low Enable (BLE#), during external access (for read or write) it indicates that the lower byte (DB8–DB15) of the data bus is the valid data transferred. When accessing the internal area it outputs a “H.”

**(6) Data Bus (DB0–DB15)**

This is the 16-bit bus used to access external devices. During external read access, data is latched from the bus synchronously with the rising edge of the read strobe. Even during 8-bit read, 16-bit data is always read in, but data only on the valid byte position is transferred into the internal circuit. During external write access, data is output from the bus. During 8-bit write, the valid byte position to write is indicated by the output signal BHW# or BLW#. When accessing the internal area, the bus functions as an input bus.

Note: • During external extension mode, these pins are switched for port upon exiting reset. Their pin functions must be set for data bus using the corresponding Port Operation Mode Register as necessary.

**(7) System Clock/Write (CLKOUT/WR#)**

The pin function changes depending on the Bus Mode Control Register (BUSMODC).

When BUSMOD = "0" and this signal is System Clock (CLKOUT), the system clock necessary to synchronize operations in external systems is output from the pin. If the CPU clock is 160 MHz, and the CLKOSEL (CLKOUT select) bit in the CLKOUT select register is set to "0," a 20 MHz clock is output; if the CLKOSEL bit is set to "1," a 40 MHz clock is output. Furthermore, if the CLKOUT/WR# function is unused, and P70MD in the P7 Operation Mode Register is cleared to "0," the pin can be used as P70; if P150MD in the P15 Operation Mode Register is cleared to "0," the pin can be used as P150.

When BUSMOD = "1" and this signal is Write (WR#), during external write access it indicates the valid data transferred on the data bus. During external read cycle and when accessing the internal area it outputs a "H."

Note: • During external extension mode, this pin is switched for port upon exiting reset. Its pin function must be set for system clock/write using the corresponding Port Operation Mode Register as necessary.

**(8) Wait (WAIT#)**

When the 32192 started an external bus cycle, it automatically inserts wait states while the WAIT# input signal is asserted. For details, see Chapter 18, "Wait Controller." If the WAIT function is unused, and P71MD in the P7 Operation Mode Register is cleared to "0," the pin can be used as P71; if P153MD in the P15 Operation Mode Register is cleared to "0," the pin can be used as P153.

Note: • During external extension mode, this pin is switched for port upon exiting reset. Its pin function must be set for wait using the corresponding Port Operation Mode Register as necessary.

**(9) Hold Control (HREQ#, HACK#)**

The hold state means internal bus and external bus stop accessing the bus and the bus interface related pins are tristated (high impedance). While the microcomputer is in a hold state, any bus master external to the chip can use the system bus to transfer data. Even during hold status the command in which command que is done though, if the command with access to bus is done, the command performance operation is stopped at that time.

An "L" signal input on the HREQ# pin places the microcomputer into a hold state. While the microcomputer remains in a hold state after accepting the hold request and during a transition to the hold state, the HACK# pin outputs a "L" level signal. To exit the hold state and return to normal operating state, release the HREQ# signal back "H."

Note: • During external extension mode, these pins are switched for port upon exiting reset. Their pin functions must be set for hold control using the corresponding Port Operation Mode Register as necessary.

**(10) Peripheral clock (BCLK)**

The peripheral clock is output from the pin. If the CPU clock is 160 MHz, a 40 MHz clock is output. Furthermore, if the BCLK output function is unused, and P70MD in the P7 Operation Mode Register is cleared to "0," the pin can be used as P70.

Note: • During external extension mode, this pin is switched for port upon exiting reset. Its pin function must be set for peripheral clock using the corresponding Port Operation Mode Register and Port Peripheral Function Select Register as necessary.

The status of each pin during hold are shown below.

**Table 17.1.1 Pin State during Hold Period**

Pin Name	Pin State or Operation
A9–A30, DB0–DB15, CS0#–CS3#, RD#, BHW#, BLW#, BHE#, BLE#, WR#	High impedance
HACK#	Output a "L"
Other pins (e.g., ports and timer output)	Normal operation

**(11) Bus power supply (VCC-BUS)**

This pin supplies power to the bus control pins. A voltage different from that of the main power supply can be applied, which is convenient when external devices are connected to the system.



## 17.2 External Bus Interface Related Registers

The following describes the external bus interface related registers.

### 17.2.1 Port Operation Mode and Port Peripheral Function Select Registers

Ports P0–P4 (except P41–P43), P124, P125, P224 and P225 are switched for external access signal pins during external extension mode when so set by the corresponding Operation Mode Register. During processor mode, these ports always function as external access signal pins.

During external extension mode, these pins are switched for port upon exiting reset. Therefore, by switching the pin functions for only those pins that are needed for external access, the remaining pins can be used as port.

Ports P70–P73, P126, P127, P150, P153, P220 and P221 can be switched for external access signal pins at any time irrespective of the CPU operation mode. Ports P41–P43 always function as external access signal pins during external extension and processor modes.

P0 Operation Mode Register (P0MOD)

<Address: H'0080 0740>

b0	1	2	3	4	5	6	b7
P00MD	P01MD	P02MD	P03MD	P04MD	P05MD	P06MD	P07MD
0	0	0	0	0	0	0	0

<Upon exiting reset: H'00>

b	Bit Name	Function	R	W
0	P00MD Port P00 operation mode bit	0: P00/DD0 (Note 1) 1: DB0/TO21 (Note 2)	R	W
1	P01MD Port P01 operation mode bit	0: P01/DD1 (Note 1) 1: DB1/TO22 (Note 2)	R	W
2	P02MD Port P02 operation mode bit	0: P02/DD2 (Note 1) 1: DB2/TO23 (Note 2)	R	W
3	P03MD Port P03 operation mode bit	0: P03/DD3 (Note 1) 1: DB3/TO24 (Note 2)	R	W
4	P04MD Port P04 operation mode bit	0: P04/DD4 (Note 1) 1: DB4/TO25 (Note 2)	R	W
5	P05MD Port P05 operation mode bit	0: P05/DD5 (Note 1) 1: DB5/TO26 (Note 2)	R	W
6	P06MD Port P06 operation mode bit	0: P06/DD6 (Note 1) 1: DB6/TO27 (Note 2)	R	W
7	P07MD Port P07 operation mode bit	0: P07/DD7 (Note 1) 1: DB7/TO28 (Note 2)	R	W

Note 1: The port and DD input functions both are effective. To use the port as DD input pin, set the port direction for input.

Note 2: Which function of the pin is used depends on how the P0 Peripheral Function Select Register is set.

Note: • During processor mode, settings of this register have no effect, and the ports function as external bus interface signal pins (DB0-DB7).

P0 Peripheral Function Select Register (P0SMOD)

&lt;Address: H'0080 0760&gt;

b0	1	2	3	4	5	6	b7
P00SMD	P01SMD	P02SMD	P03SMD	P04SMD	P05SMD	P06SMD	P07SMD
0	0	0	0	0	0	0	0

&lt;Upon exiting reset: H'00&gt;

b	Bit Name	Function	R	W
0	P00SMD Port P00 peripheral function select bit	0: DB0 1: TO21	R	W
1	P01SMD Port P01 peripheral function select bit	0: DB1 1: TO22	R	W
2	P02SMD Port P02 peripheral function select bit	0: DB2 1: TO23	R	W
3	P03SMD Port P03 peripheral function select bit	0: DB3 1: TO24	R	W
4	P04SMD Port P04 peripheral function select bit	0: DB4 1: TO25	R	W
5	P05SMD Port P05 peripheral function select bit	0: DB5 1: TO26	R	W
6	P06SMD Port P06 peripheral function select bit	0: DB6 1: TO27	R	W
7	P07SMD Port P07 peripheral function select bit	0: DB7 1: TO28	R	W

- Notes:
- During processor mode, settings of this register have no effect, and the ports function as external bus interface signal pins (DB0-DB7).
  - The value of this register can only be modified when the corresponding P0 operation mode register bit = 0 (set for port). Then set the corresponding P0 operation mode register bit to "1."
  - During single-chip mode, selecting the external bus interface function is prohibited.

P1 Operation Mode Register (P1MOD)

&lt;Address: H'0080 0741&gt;

b8	9	10	11	12	13	14	b15
P10MD	P11MD	P12MD	P13MD	P14MD	P15MD	P16MD	P17MD
0	0	0	0	0	0	0	0

&lt;Upon exiting reset: H'00&gt;

b	Bit Name	Function	R	W
8	P10MD Port P10 operation mode bit	0: P10/DD8 (Note 1) 1: DB8/TO29 (Note 2)	R	W
9	P11MD Port P11 operation mode bit	0: P11/DD9 (Note 1) 1: DB9/TO30 (Note 2)	R	W
10	P12MD Port P12 operation mode bit	0: P12/DD10 (Note 1) 1: DB10/TO31 (Note 2)	R	W
11	P13MD Port P13 operation mode bit	0: P13/DD11 (Note 1) 1: DB11/TO32 (Note 2)	R	W
12	P14MD Port P14 operation mode bit	0: P14/DD12 (Note 1) 1: DB12/TO33 (Note 2)	R	W
13	P15MD Port P15 operation mode bit	0: P15/D13 (Note 1) 1: DB13/TO34 (Note 2)	R	W
14	P16MD Port P16 operation mode bit	0: P16/DD14 (Note 1) 1: DB14/TO35 (Note 2)	R	W
15	P17MD Port P17 operation mode bit	0: P17/DD15 (Note 1) 1: DB15/TO36 (Note 2)	R	W

Note 1: The port and DD input functions both are effective. To use the port as DD input pin, set the port direction for input.

Note 2: Which function of the pin is used depends on how the P1 Peripheral Function Select Register is set.

Note: • During processor mode, settings of this register have no effect, and the ports function as external bus interface signal pins (DB8-DB15).

P1 Peripheral Function Select Register (P1SMOD)

&lt;Address: H'0080 0761&gt;

b8	9	10	11	12	13	14	b15
P10SMD	P11SMD	P12SMD	P13SMD	P14SMD	P15SMD	P16SMD	P17SMD
0	0	0	0	0	0	0	0

&lt;Upon exiting reset: H'00&gt;

b	Bit Name	Function	R	W
8	P10SMD Port P10 peripheral function select bit	0: DB8 1: TO29	R	W
9	P11SMD Port P11 peripheral function select bit	0: DB9 1: TO30	R	W
10	P12SMD Port P12 peripheral function select bit	0: DB10 1: TO31	R	W
11	P13SMD Port P13 peripheral function select bit	0: DB11 1: TO32	R	W
12	P14SMD Port P14 peripheral function select bit	0: DB12 1: TO33	R	W
13	P15SMD Port P15 peripheral function select bit	0: DB13 1: TO34	R	W
14	P16SMD Port P16 peripheral function select bit	0: DB14 1: TO35	R	W
15	P17SMD Port P17 peripheral function select bit	0: DB15 1: TO36	R	W

Notes: • During processor mode, settings of this register have no effect, and the ports function as external bus interface signal pins (DB8-DB15).

• The value of this register can only be modified when the corresponding P1 operation mode register bit = 0 (set for port). Then set the corresponding P1 operation mode register bit to "1."

• During single-chip mode, selecting the external bus interface function is prohibited.

P2 Operation Mode Register (P2MOD)

&lt;Address: H'0080 0742&gt;

b0	1	2	3	4	5	6	b7
P20MD	P21MD	P22MD	P23MD	P24MD	P25MD	P26MD	P27MD
0	0	0	0	0	0	0	0

&lt;Upon exiting reset: H'00&gt;

b	Bit Name	Function	R	W
0	P20MD Port P20 operation mode bit	0: P20/DD24 (Note 1) 1: A23	R	W
1	P21MD Port P21 operation mode bit	0: P21/DD25 (Note 1) 1: A24	R	W
2	P22MD Port P22 operation mode bit	0: P22/DD26 (Note 1) 1: A25	R	W
3	P23MD Port P23 operation mode bit	0: P23/DD27 (Note 1) 1: A26	R	W
4	P24MD Port P24 operation mode bit	0: P24/DD28 (Note 1) 1: A27	R	W
5	P25MD Port P25 operation mode bit	0: P25/DD29 (Note 1) 1: A28	R	W
6	P26MD Port P26 operation mode bit	0: P26/DD30 (Note 1) 1: A29	R	W
7	P27MD Port P27 operation mode bit	0: P27/DD31 (Note 1) 1: A30	R	W

Note 1: The port and DD input functions both are effective. To use the port as DD input pin, set the port direction for input.

Notes: • During single-chip mode, settings of this register have no effect, and the port functions as port input/output or DD input pin.

- During processor mode, settings of this register have no effect, and the ports function as external bus interface signal pins (A23-A30).

P3 Operation Mode Register (P3MOD)

&lt;Address: H'0080 0743&gt;

b8	9	10	11	12	13	14	b15
P30MD	P31MD	P32MD	P33MD	P34MD	P35MD	P36MD	P37MD
0	0	0	0	0	0	0	0

&lt;Upon exiting reset: H'00&gt;

b	Bit Name	Function	R	W
8	P30MD Port P30 operation mode bit	0: P30/DD16 (Note 1) 1: A15/TIN4 (Note 2)	R	W
9	P31MD Port P31 operation mode bit	0: P31/DD17 (Note 1) 1: A16/TIN5 (Note 2)	R	W
10	P32MD Port P32 operation mode bit	0: P32/DD18 (Note 1) 1: A17/TIN6 (Note 2)	R	W
11	P33MD Port P33 operation mode bit	0: P33/DD19 (Note 1) 1: A18/TIN17 (Note 2)	R	W
12	P34MD Port P34 operation mode bit	0: P34/DD20 (Note 1) 1: A19/TIN30 (Note 2)	R	W
13	P35MD Port P35 operation mode bit	0: P35/DD21 (Note 1) 1: A20/TIN31 (Note 2)	R	W
14	P36MD Port P36 operation mode bit	0: P36/DD22 (Note 1) 1: A21/TIN32 (Note 2)	R	W
15	P37MD Port P37 operation mode bit	0: P37/DD23 (Note 1) 1: A22/TIN33 (Note 2)	R	W

Note 1: The port and DD input functions both are effective. To use the port as DD input pin, set the port direction for input.

Note 2: Which function of the pin is used depends on how the P3 Peripheral Function Select Register is set.

Note: • During processor mode, settings of this register have no effect, and the ports function as external bus interface signal pins (A15-A22).

P3 Peripheral Function Select Register (P3SMOD)

&lt;Address: H'0080 0763&gt;

b8	9	10	11	12	13	14	b15
P30SMD	P31SMD	P32SMD	P33SMD	P34SMD	P35SMD	P36SMD	P37SMD
0	0	0	0	0	0	0	0

&lt;Upon exiting reset: H'00&gt;

b	Bit Name	Function	R	W
8	P30SMD Port P30 peripheral function select bit	0: A15 1: TIN4	R	W
9	P31SMD Port P31 peripheral function select bit	0: A16 1: TIN5	R	W
10	P32SMD Port P32 peripheral function select bit	0: A17 1: TIN6	R	W
11	P33SMD Port P33 peripheral function select bit	0: A18 1: TIN7	R	W
12	P34SMD Port P34 peripheral function select bit	0: A19 1: TIN30	R	W
13	P35SMD Port P35 peripheral function select bit	0: A20 1: TIN31	R	W
14	P36SMD Port P36 peripheral function select bit	0: A21 1: TIN32	R	W
15	P37SMD Port P37 peripheral function select bit	0: A22 1: TIN33	R	W

Notes: • During processor mode, settings of this bit have no effect and the ports function as external bus interface signal pins (A15-A22).

- The value of this register can only be modified when the corresponding P3 operation mode register bit = 0 (set for port). Then set the corresponding P3 operation mode register bit to "1."
- During single-chip mode, selecting the external bus interface function is prohibited.

P4 Operation Mode Register (P4MOD)

&lt;Address: H'0080 0744&gt;

b0	1	2	3	4	5	6	b7
0	0	0	0	P44MD 0	P45MD 0	P46MD 0	P47MD 0

&lt;Upon exiting reset: H'00&gt;

b	Bit Name	Function	R	W
0–3	No function assigned. Fix to "0."		0	0
4	P44MD Port P44 operation mode bit	0: P44 1: CS0#/TIN8 (Note 1)	R	W
5	P45MD Port P45 operation mode bit	0: P45 1: CS1#/TIN9 (Note 1)	R	W
6	P46MD Port P46 operation mode bit	0: P46 1: A13/TIN10 (Note 1)	R	W
7	P47MD Port P47 operation mode bit	0: P47 1: A14/TIN11 (Note 1)	R	W

Note 1: Which function of the pin is used depends on how the P4 Peripheral Function Select Register is set.

Note: • During processor mode, settings of this register have no effect, and the ports function as external bus interface signal pins (CS0#, CS1#, A13 and A14).

P4 Peripheral Function Select Register (P4SMOD)

&lt;Address: H'0080 0764&gt;

b0	1	2	3	4	5	6	b7
0	0	0	0	P44SMD 0	P45SMD 0	P46SMD 0	P47SMD 0

&lt;Upon exiting reset: H'00&gt;

b	Bit Name	Function	R	W
0–3	No function assigned. Fix to "0."		0	0
4	P44SMD Port P44 peripheral function select bit	0: CS0# 1: TIN8	R	W
5	P45SMD Port P45 peripheral function select bit	0: CS1# 1: TIN9	R	W
6	P46SMD Port P46 peripheral function select bit	0: A13 1: TIN10	R	W
7	P47SMD Port P47 peripheral function select bit	0: A14 1: TIN11	R	W

Notes: • During processor mode, settings of this register have no effect, and the ports function as external bus interface signal pins (CS0#, CS1#, A13 and A14).

- The value of this register can only be modified when the corresponding P4 operation mode register bit = 0 (set for port). Then set the corresponding P4 operation mode register bit to "1."
- During single-chip mode, selecting the external bus interface function is prohibited.

P7 Operation Mode Register (P7MOD)

&lt;Address: H'0080 0747&gt;

b8	9	10	11	12	13	14	b15
P70MD	P71MD	P72MD	P73MD	P74MD	P75MD	P76MD	P77MD
0	0	0	0	0	0	0	0

&lt;Upon exiting reset: H'00&gt;

b	Bit Name	Function	R	W
8	P70MD Port P70 operation mode bit	0: P70 1: CLKOUT/WR#/BCLK (Note 1)	R	W
9	P71MD Port P71 operation mode bit	0: P71 1: WAIT# (Note 2)	R	W
10	P72MD Port P72 operation mode bit	0: P72 1: HREQ#/TIN27 (Note 3)	R	W
11	P73MD Port P73 operation mode bit	0: P73 1: HACK#/TIN26 (Note 3)	R	W
12	P74MD Port P74 operation mode bit (Note 4)	0: P74 1: RTDXTD/TXD3 (Note 3)	R	W
13	P75MD Port P75 operation mode bit (Note 4)	0: P75 1: RTDRXD/RXD3 (Note 3)	R	W
14	P76MD Port P76 operation mode bit (Note 4)	0: P76 1: RTDACK/CTX1 (Note 3)	R	W
15	P77MD Port P77 operation mode bit (Note 4)	0: P77 1: RTDCLK/CRX1 (Note 3)	R	W

Note 1: These functions are selected using the P7 Peripheral Function Select Register and Bus Mode Control Register.

Note 2: During single-chip mode, settings of this register have no effect, and the port functions as port input/output pin.

Note 3: These functions are selected using the P7 Peripheral Function Select Register.

Note 4: If the NBD function is selected by the NBD Pin Control Register, the port functions as NBD pin no matter how this register is set.

P7 Peripheral Function Select Register (P7SMOD)

&lt;Address: H'0080 0767&gt;

b8	9	10	11	12	13	14	b15
P70SMD		P72SMD	P73SMD	P74SMD	P75SMD	P76SMD	P77SMD
0	0	0	0	0	0	0	0

&lt;Upon exiting reset: H'00&gt;

b	Bit Name	Function	R	W
8	P70SMD Port P70 peripheral function select bit	0: CLKOUT/WR# (Note 1) 1: BCLK	R	W
9	No function assigned. Fix to "0."		0	0
10	P72SMD Port P72 peripheral function select bit	0: HREQ# 1: TIN27	R	W
11	P73SMD Port P73 peripheral function select bit	0: HACK# 1: TIN26	R	W
12	P74SMD (Note 2) Port P74 peripheral function select bit	0: RTDXTD 1: TXD3	R	W
13	P75SMD (Note 2) Port P75 peripheral function select bit	0: RTDRXD 1: RXD3	R	W
14	P76SMD (Note 2) Port P76 peripheral function select bit	0: RTDACK 1: CTX1	R	W
15	P77SMD (Note 2) Port P77 peripheral function select bit	0: RTDCLK 1: CRX1	R	W

Note 1: Which function of the pin is used depends on how the Bus Mode Control Register is set.

Note 2: If the NBD function is selected by the NBD Pin Control Register, the port functions as NBD pin no matter how this register is set.

Note: • The value of this register can only be modified when the corresponding P7 operation mode register bit = 0 (set for port).

Then set the corresponding P7 operation mode register bit to "1."

P12 Operation Mode Register (P12MOD)

<Address: H'0080 074C>

b0	1	2	3	4	5	6	b7
				P124MD	P125MD	P126MD	P127MD
0				0	0	0	0

<Upon exiting reset: H'00>

b	Bit Name	Function	R	W
0–3	No function assigned. Fix to "0."		0	0
4	P124MD Port P124 operation mode bit (Note 3)	0: P124/DD3 (Note 1) 1: TCLK0/A9 (Note 2)	R	W
5	P125MD Port P125 operation mode bit (Note 3)	0: P125/DD2 (Note 1) 1: TCLK1/A10 (Note 2)	R	W
6	P126MD Port P126 operation mode bit	0: P126/DD1 (Note 1) 1: TCLK2/CS2# (Note 2)	R	W
7	P127MD Port P127 operation mode bit	0: P127/DD0 (Note 1) 1: TCLK3/CS3# (Note 2)	R	W

Note 1: The DD input functions are effective depending on the settings of DD input pin select register (DDSEL). (For details, refer to the Chapter 14, "Direct RAM Interface"). To use the port as DD input pin, set the port direction for input.

Note 2: Which function of the pin is used depends on how the P12 Peripheral Function Select Register is set.

Note 3: During processor mode, settings of this bit have no effect and the port functions as external bus interface signal pin (A9 or A10).

P12 Peripheral Function Select Register (P12SMOD)

<Address: H'0080 076C>

b0	1	2	3	4	5	6	b7
				P124SMD	P125SMD	P126SMD	P127SMD
0				0	0	0	0

<Upon exiting reset: H'00>

b	Bit Name	Function	R	W
0–3	No function assigned. Fix to "0."		0	0
4	P124SMD Port P124 peripheral function select bit (Note 1)	0: TCLK0 1: A9	R	W
5	P125SMD Port P125 peripheral function select bit (Note 1)	0: TCLK1 1: A10	R	W
6	P126SMD Port P126 peripheral function select bit	0: TCLK2 1: CS2#	R	W
7	P127SMD Port P127 peripheral function select bit	0: TCLK3 1: CS3#	R	W

Note 1: During processor mode, settings of this bit have no effect and the port functions as external bus interface signal pin (A9 or A10).

Note: • The value of this register can only be modified when the corresponding P12 operation mode register bit = "0" (set for port). Then set the corresponding P12 operation mode register bit to "1."



P15 Operation Mode Register (P15MOD)

&lt;Address: H'0080 074F&gt;

b8	9	10	11	12	13	14	b15
P150MD			P153MD				
0	0	0	0	0	0	0	0

&lt;Upon exiting reset: H'00&gt;

b	Bit Name	Function	R	W
8	P150MD Port P150 operation mode bit	0: P150 1: TIN0/CLKOUT/WR# (Note 1)	R	W
9, 10	No function assigned. Fix to "0."		0	0
11	P153MD Port P153 operation mode bit	0: P153 1: TIN3/WAIT# (Note 2)	R	W
12–15	No function assigned. Fix to "0."		0	0

Note 1: Which function of the pin is used depends on how the P15 Peripheral Function Select Register and Bus Mode Control Register are set.

Note 2: Which function of the pin is used depends on how the P15 Peripheral Function Select Register is set.

P15 Peripheral Function Select Register (P15SMOD)

&lt;Address: H'0080 076F&gt;

b8	9	10	11	12	13	14	b15
P150SMD			P153SMD				
0	0	0	0	0	0	0	0

&lt;Upon exiting reset: H'00&gt;

b	Bit Name	Function	R	W
8	P150SMD Port P150 peripheral function select bit	0: TIN0 1: CLKOUT/WR# (Note 1)	R	W
9, 10	No function assigned. Fix to "0."		0	0
11	P153SMD Port P153 peripheral function select bit (Note 2)	0: TIN3 1: WAIT#	R	W
12–15	No function assigned. Fix to "0."		0	0

Note 1: Which function of the pin is used depends on how the Bus Mode Control Register is set.

Note 2: During single-chip mode, selecting the external bus interface signal function is prohibited.

Note: • The value of this register can only be modified when the corresponding P15 operation mode register bit = "0" (set for port). Then set the corresponding P15 operation mode register bit to "1."

P22 Operation Mode Register (P22MOD)

&lt;Address: H'0080 0756&gt;

b0	1	2	3	4	5	6	b7
P220MD	P221MD			P224MD	P225MD		
0	0	0	0	0	0	0	0

&lt;Upon exiting reset: H'00&gt;

b	Bit Name	Function	R	W
0	P220MD Port P220 operation mode bit	0: P220 1: CTX0/HACK# (Note 1)	R	W
1	P221MD Port P221 operation mode bit	0: P221 1: CRX0/HREQ# (Note 1)	R	W
2, 3	No function assigned. Fix to "0."		0	0
4	P224MD Port P224 operation mode bit (Note 2)	0: P224 1: A11/CS2# (Note 1)	R	W
5	P225MD Port P225 operation mode bit (Note 2)	0: P225 1: A12/CS3# (Note 1)	R	W
6, 7	No function assigned. Fix to "0."		0	0

Note 1: Which function of the pin is used depends on how the P22 Peripheral Function Select Register is set.

Note 2: During processor mode, settings of this bit have no effect and the port functions as external bus interface signal pin (A11/CS2# or A12/CS3#).

P22 Peripheral Function Select Register (P22SMOD)

&lt;Address: H'0080 0776&gt;

b0	1	2	3	4	5	6	b7
P220SMD	P221SMD			P224SMD	P225SMD		
0	0	0	0	0	0	0	0

&lt;Upon exiting reset: H'00&gt;

b	Bit Name	Function	R	W
0	P220SMD Port P220 peripheral function select bit	0: CTX0 1: HACK#	R	W
1	P221SMD Port P221 peripheral function select bit	0: CRX0 1: HREQ#	R	W
2, 3	No function assigned. Fix to "0."		0	0
4	P224SMD Port P224 peripheral function select bit (Note 1)	0: A11 1: CS2#	R	W
5	P225SMD Port P225 peripheral function select bit (Note 1)	0: A12 1: CS3#	R	W
6, 7	No function assigned. Fix to "0."		0	0

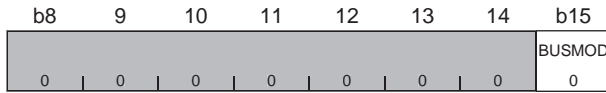
Note 1: During single-chip mode, selecting the external bus interface signal function is prohibited.

Note: • The value of this register can only be modified when the corresponding P22 operation mode register bit = "0" (set for port). Then set the corresponding P22 operation mode register bit to "1."

#### 17.2.2 Bus Mode Control Register

Bus Mode Control Register (BUSMODC)

<Address: H'0080 077F>



<Upon exiting reset: H'00>

b	Bit Name	Function	R	W
8–14	No function assigned. Fix to "0."		0	0
15	BUSMOD Bus mode control bit	0: WR signal separate mode 1: Byte enable separate mode	R	W

This register is used to facilitate memory connections during processor mode and external extension mode.

When the Bus Mode Control bit (BUSMOD) = "0," the WR# signal is output separately for each byte area. Signals RD#, BHW#, BLW#, CLKOUT, WAIT# and BCLK can be used.

When the Bus Mode Control bit (BUSMOD) = "1," the byte enable signal is output separately for each byte area. Signals RD#, BHE#, BLE#, WR#, WAIT# and BCLK can be used. In a WAIT control circuit configuration, because CLKOUT output is not available, timing must be controlled by BCLK or external to the chip.

For memory connection in boot mode, the Bus Mode Control Register has no effect, and the microcomputer operates in the same way as when the Bus Mode Control bit (BUSMOD) is cleared to "0."

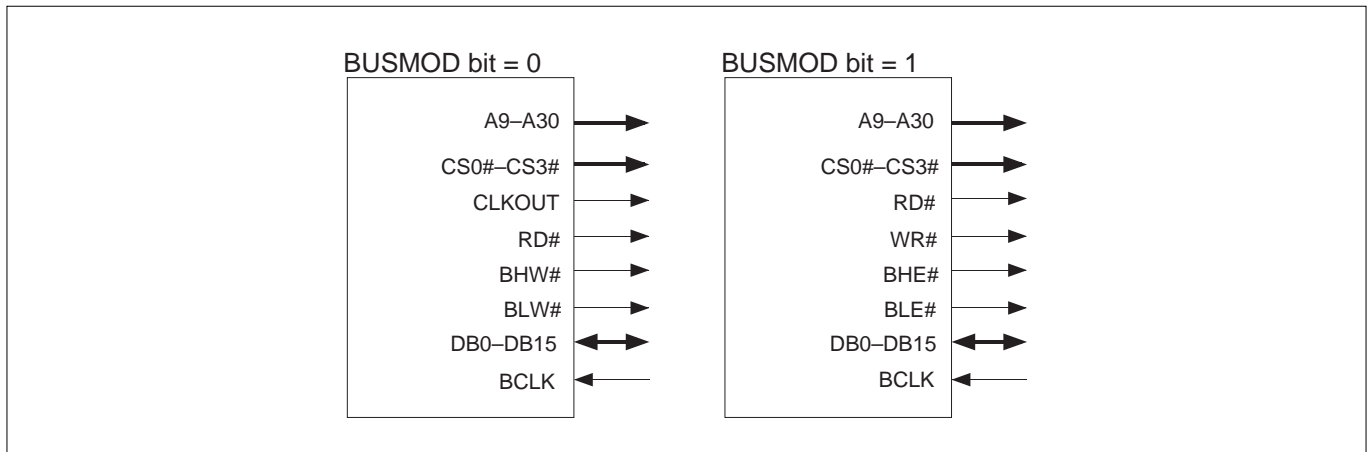


Figure 17.2.1 Pin Functions when External Bus Modes are Changed

### 17.2.3 CLKOUT Select Register

CLKOUT Select Register (CLKOUTSEL)

<Address: H'0080 01A0>

b0	1	2	3	4	5	6	b7
0	0	0	0	0	0	0	0

<Upon exiting reset: H'00>

b	Bit Name	Function	R	W
0–5	No function assigned. Fix to"0."		0	0
6	CLKOSEL P CLKOSEL write control bit		0	W
7	CLKOSEL CLKOUT select bit	0: BCLK divided by 2 1: BCLK	R	W

Notes: • At the timing for CLKOUT changes from divided-by-2 BCLK to straight BCLK or vice versa, there will be some indefinite output.  
• When BCLK is selected as a CLKOUT terminal output, regardless of CS0-CS3 is used or not, it is prohibition that selecting 0 wait in WAIT (the number selection of internal wait) bit of a CSn area wait control register.

#### (1) CLKOSEL P (CLKOSEL Write Control) bit (Bit 6)

This bit controls write to the CLKOUT select bit.

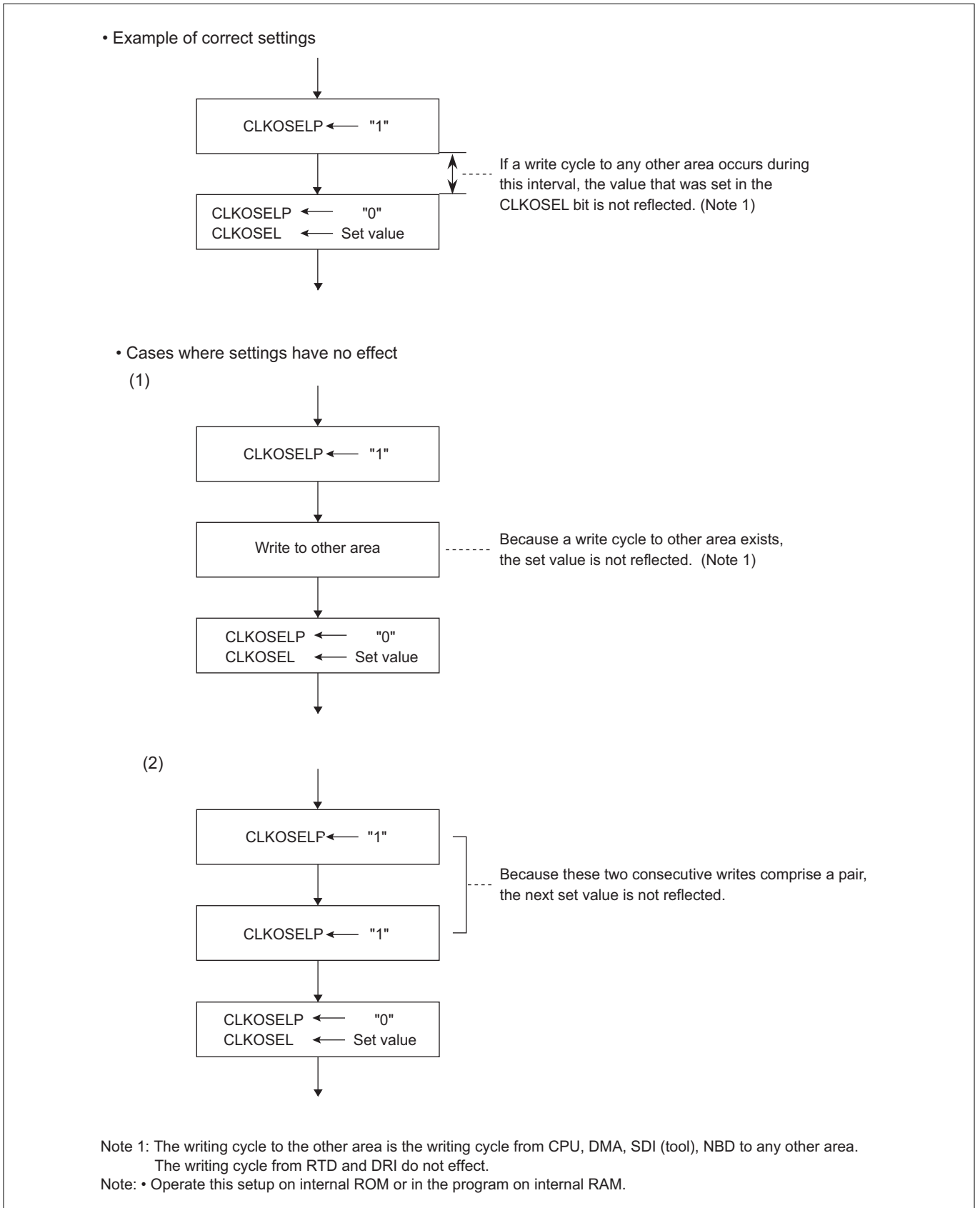
#### (2) CLKOUT (CLKOSEL) Select bit (Bit 7)

This bit selects straight BCLK or divided-by-2 BCLK as outputting of CLKOUT (external bus synchronous clock) pin. If the CPU clock is 160 MHz, BCLK is 40 MHz. If CLKOSEL is cleared to "0," CLKOUT or the external bus reference clock is 20 MHz; if CLKOSEL is set to "1," CLKOUT is 40 MHz. The number of wait states set by the CSn area wait control register, as well as CSn wait, strobe wait, recovery cycles and idle cycles after read all are synchronized to CLKOUT.

However when "1" is selected in CLKOSEL bit (BCLK is selected as a CLKOUT terminal output), regardless of CS0-CS3 is used or not, it is prohibition that selecting 0 wait in WAIT (the number selection of internal wait) bit of a CSn area wait control register.

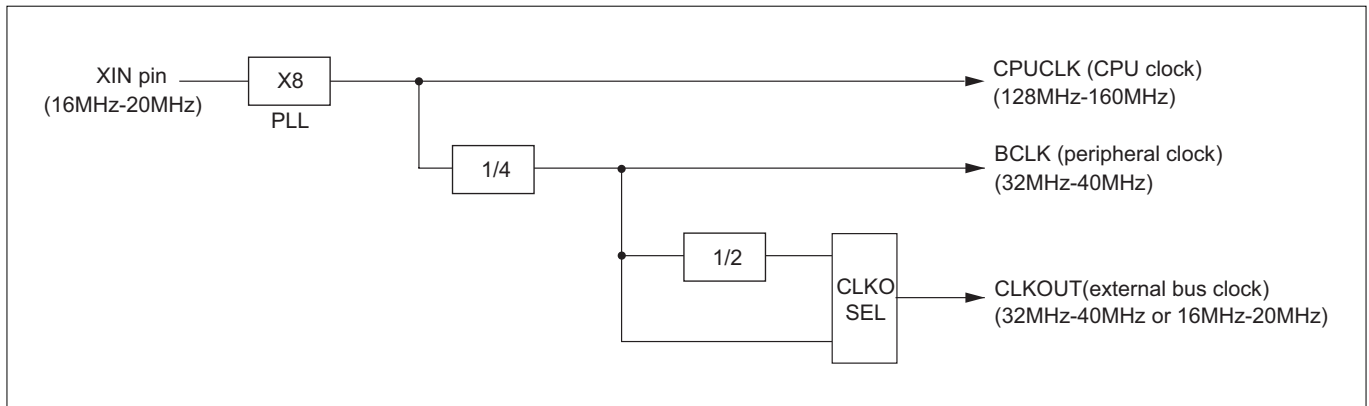
The following describes how to set the CLKOSEL (CLKOUT select) bit

1. The program in the internal ROM or the internal RAM should be used to set the bits.
2. Write "1" to the CLKOSEL write control bit (CLKOSEL P).
3. Subsequent to 2 above, write "0" to the CLKOSEL write control bit (CLKOSEL P) and then "0" or "1" whichever desired to the CLKOUT select bit (CLKOSEL).
4. After writing to the above bits, access any SFR area for read twice.



**Figure 17.2.2 Setting procedure of CLKOUT Select (CLKOSEL) bit**

Figure 17.2.3 shows the clock configuration of CPUCLK, BCLK and CLKOUT.

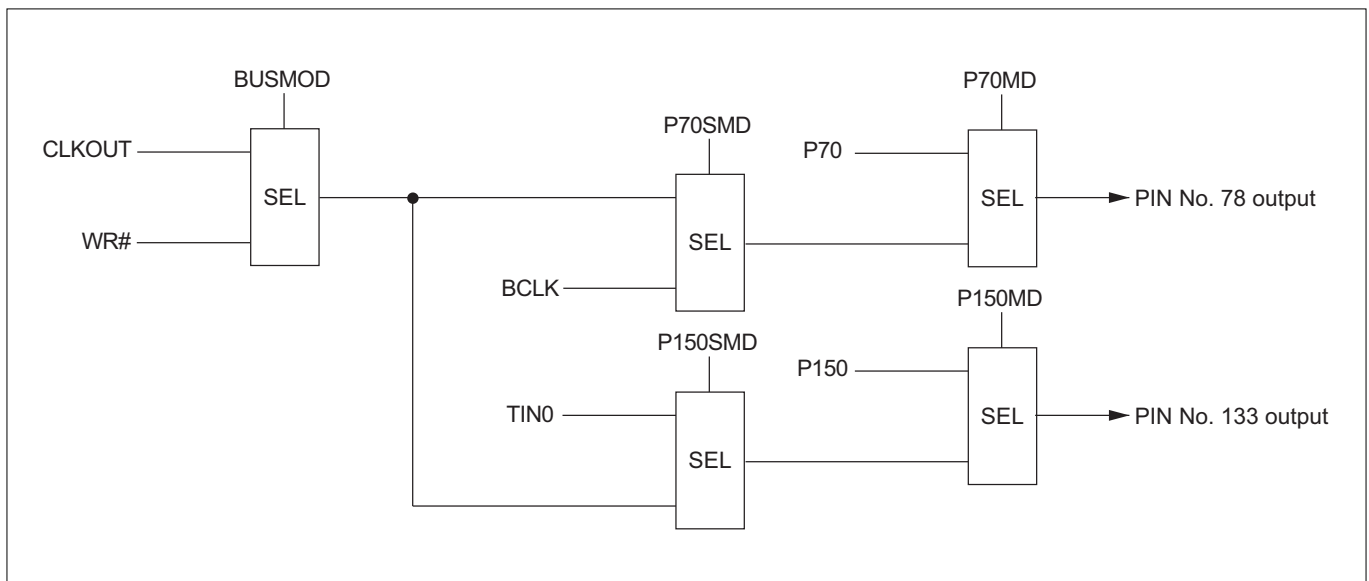


**Figure 17.2.3 Block Diagram of the Clock Configuration**

The output pins for the peripheral clock BCLK and the external bus clock BCLKOUT are listed in Table 17.2.1. A CLKOUT and BCLK select structure is shown in Figure 17.2.4.

**Table 17.2.1 Output Pins for CLKOUT and BCLK**

PIN No.	Pin Name	Function	Set Value
78	P70/CLKOUT/WR#/BCLK	P70	P70MD=0
		CLKOUT	P70MD=1, P70SMD=0, BUSMOD=0
		WR#	P70MD=1, P70SMD=0, BUSMOD=1
		BCLK	P70MD=1, P70SMD=1
133	P150/TIN0/CLKOUT/WR#	P150	P150MD=0
		TIN0	P150MD=1, P150SMD=0
		CLKOUT	P150MD=1, P150SMD=1, BUSMOD=0
		WR#	P150MD=1, P150SMD=1, BUSMOD=1



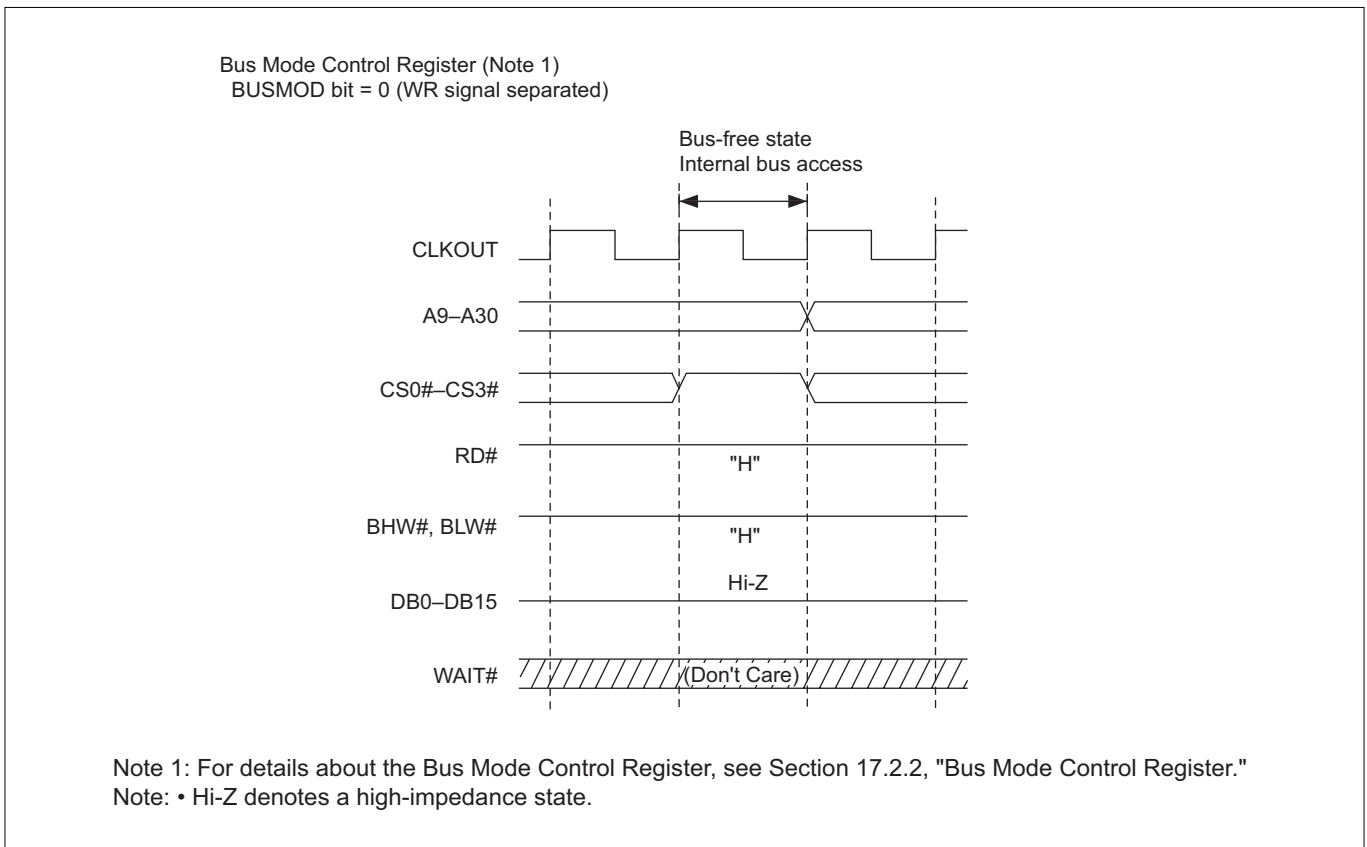
**Figure 17.2.4 A CLKOUT and BCLK Select Structure**

### 17.3 Read/Write Operations

#### (1) When the Bus Mode Control Register = "0"

External read/write operations are performed using the address bus, data bus and the signals CS0#–CS3#, RD#, BHW#, BLW#, WAIT#, CLKOUT and BCLK. In the external read cycle, the RD# signal is "L" while BHW# and BLW# both are "H," with data read in from only the necessary byte position. In the external write cycle, the BHW# or BLW# signal output for the byte position to which to write is asserted "L" as data is written to the bus.

When an external bus cycle starts, wait states are inserted as long as the WAIT# signal is "L." Unless necessary, the WAIT# signal must always be held "H." If the WAIT function is unused, and P71MD in the P7 Operation Mode Register or P153MD in the P15 Operation Mode Register is cleared to "0", the pin can be used as port.

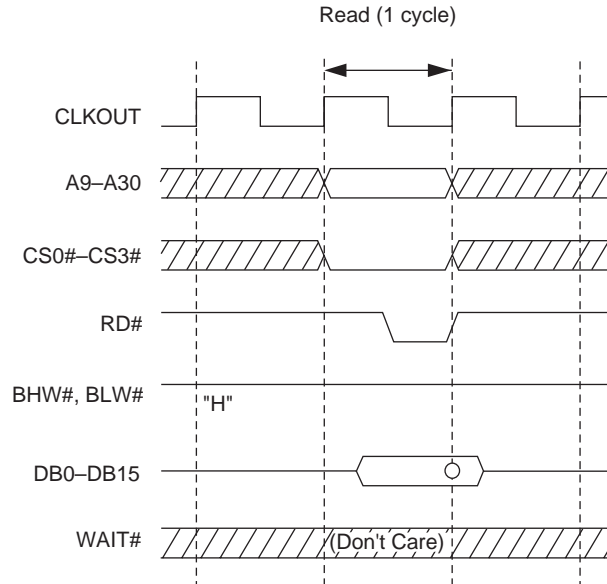


**Figure 17.3.1 Internal Bus Access during Bus Free State**

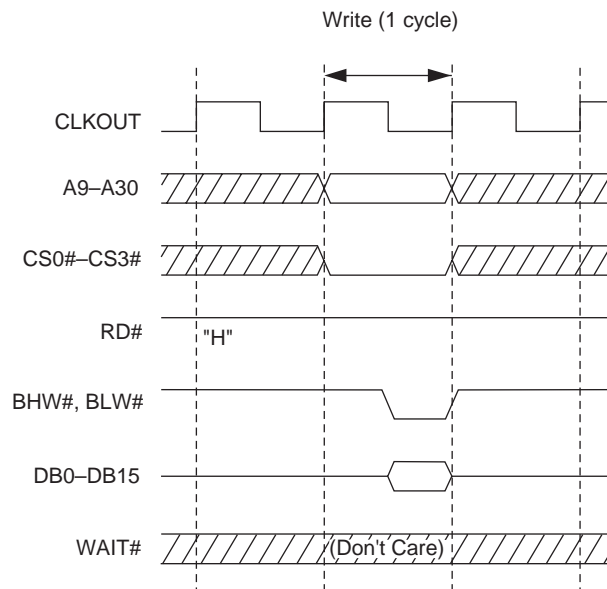
Bus Mode Control Register (Note 1)  
 BUSMOD bit = 0 (WR signal separated)

CS Area Wait Control Register (Note 2)  
 WAIT bit = 0000 (zero wait)  
 CWAIT bit = 0 (without CS wait)  
 SWAIT bit = 0 (without strobe wait)  
 RECOV bit = 0 (without recovery cycle)  
 IDLE bit = 0 (without idle cycle)

Read



Write



Note 1: For details about the Bus Mode Control Register, see Section 17.2.2, "Bus Mode Control Register."

Note 2: For details about the CS Area Wait Control Register, see Section 18.2.1, "CS Area Wait Control Registers."

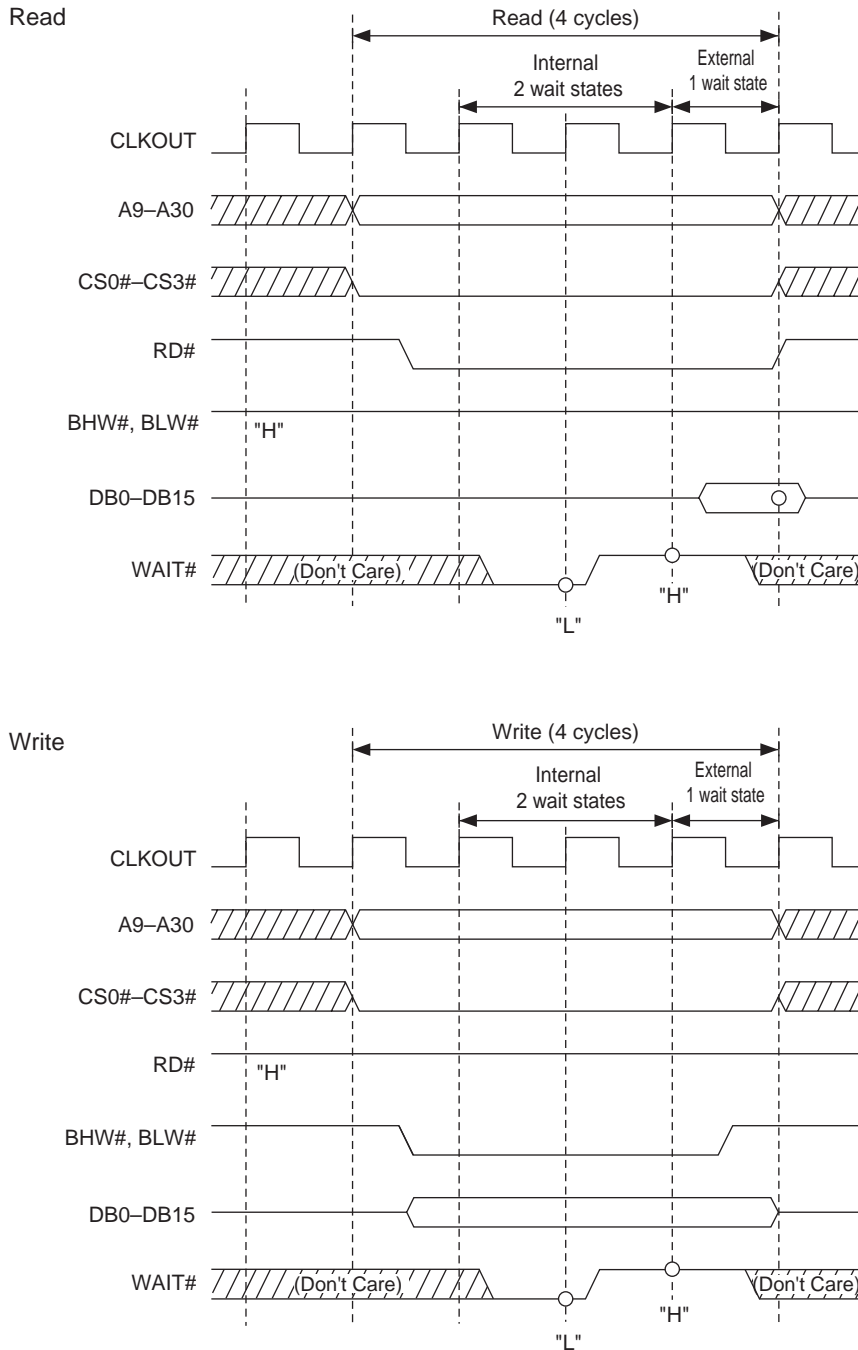
Note: • When zero wait state is selected, assertion of WAIT# is not accepted.

**Figure 17.3.2 Read/Write Timing (for Zero Wait Access)**



Bus Mode Control Register (Note 1)  
 BUSMOD bit = 0 (WR signal separated)

CS Area Wait Control Register (Note 2)  
 WAIT bit = 0010 (2 wait)  
 CWAIT bit = 0 (without CS wait)  
 SWAIT bit = 0 (without strobe wait)  
 RECOV bit = 0 (without recovery cycle)  
 IDLE bit = 0 (without idle cycle)



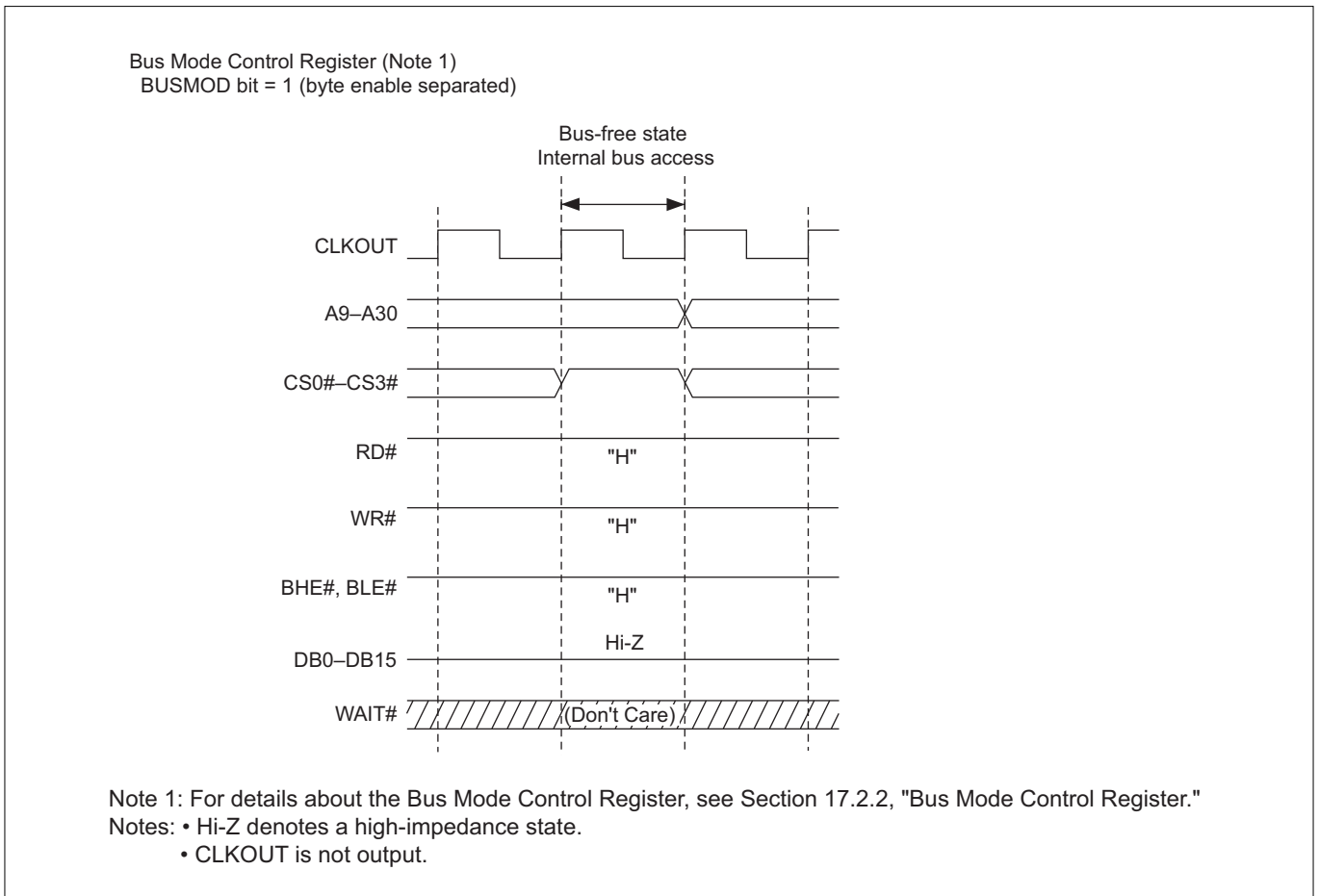
Note 1: For details about the Bus Mode Control Register, see Section 17.2.2, "Bus Mode Control Register."  
 Note 2: For details about the CS Area Wait Control Register, see Section 18.2.1, "CS Area Wait Control Registers."  
 Note: • Circles in the above diagram denote the sampling timing.

Figure 17.3.3 Read/Write Timing (for Access with Internal 2 and External 1 Wait States)

#### (2) When the Bus Mode Control Register is set to "1"

External read/write operations are performed using the address bus, data bus and the signals CS0#–CS3#, RD#, BHE#, BLE#, WAIT#, WR# and BCLK. In the external read cycle, the RD# signal is "L" and the BHE# or BLE# signal output for the byte position from which to read is asserted "L," with data read in from only the necessary byte position of the bus. In the external write cycle, the WR# signal goes "L" and the BHE# or BLE# signal output for the byte position to which to write is asserted "L," with data written to the necessary byte position.

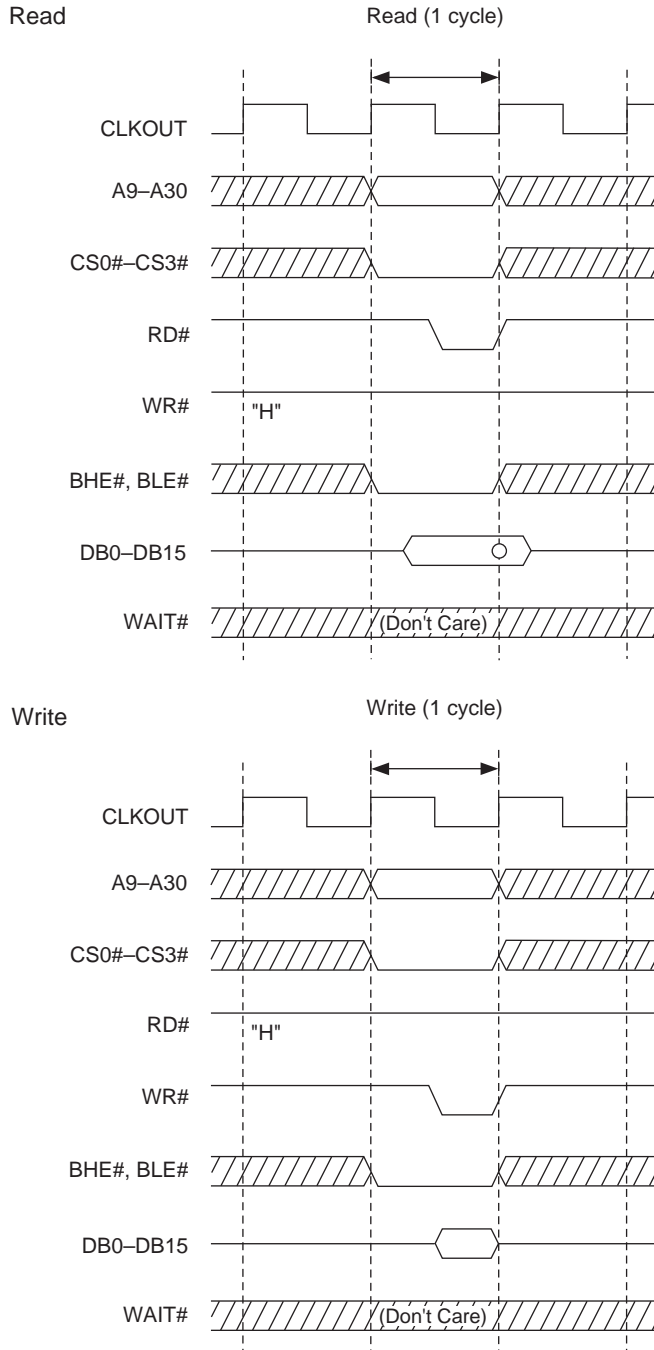
When an external bus cycle starts, wait states are inserted as long as the WAIT# signal is "L." Unless necessary, the WAIT# signal must always be held "H."



**Figure 17.3.4 Internal Bus Access during Bus Free State**

Bus Mode Control Register (Note 1)  
 BUSMOD bit = 1 (byte enable separated)

CS Area Wait Control Register (Note 2)  
 WAIT bit = 0000 (zero wait)  
 CWAIT bit = 0 (without CS wait)  
 SWAIT bit = 0 (without strobe wait)  
 RECOV bit = 0 (without recovery cycle)  
 IDLE bit = 0 (without idle cycle)



Note 1: For details about the Bus Mode Control Register, see Section 17.2.2, "Bus Mode Control Register."

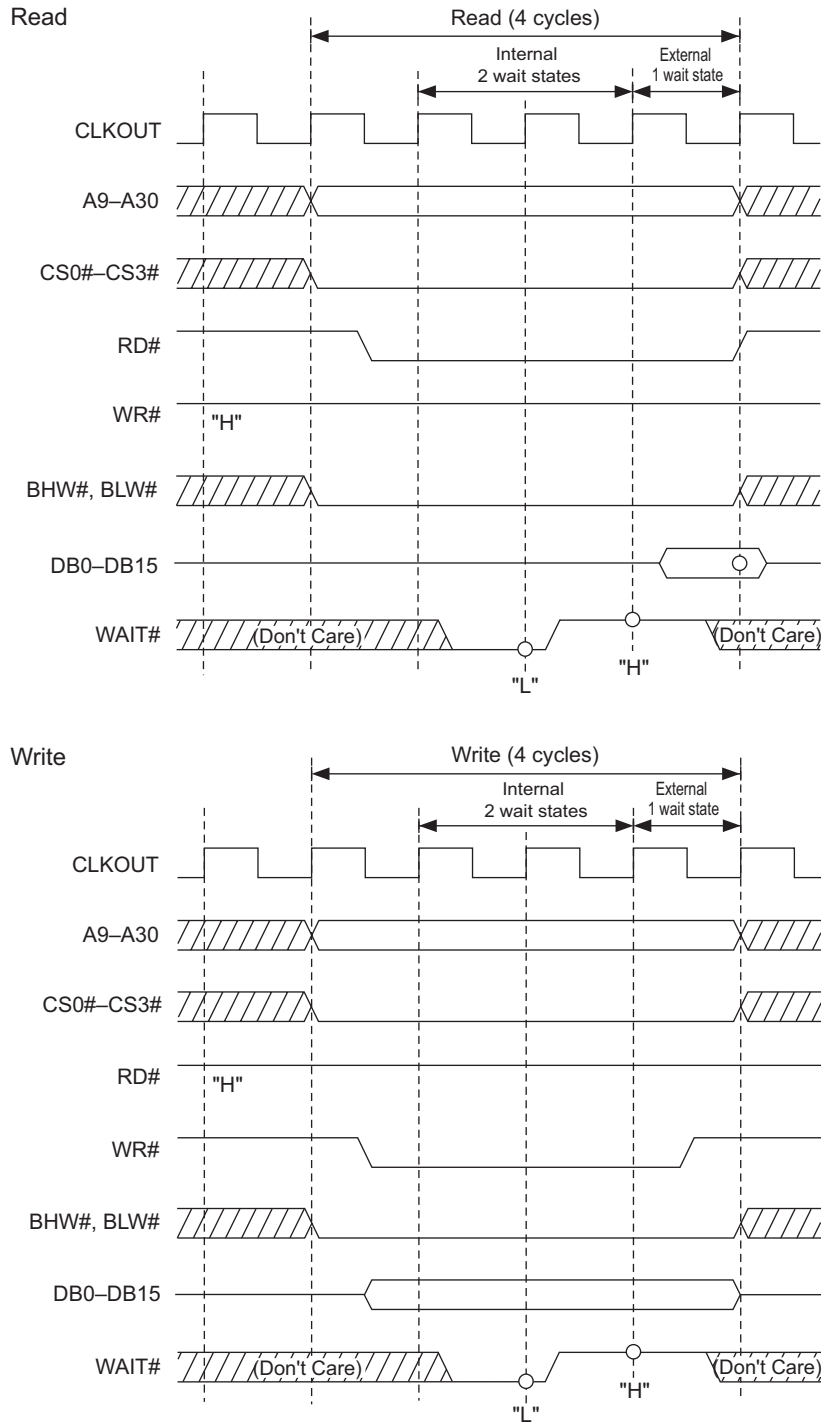
Note 2: For details about the CS Area Wait Control Register, see Section 18.2.1, "CS Area Wait Control Registers."

- Notes:
- When zero wait state is selected, assertion of WAIT# is not accepted.
  - CLKOUT is not output.

Figure 17.3.5 Read/Write Timing (for Zero Wait Access)

Bus Mode Control Register (Note 1)  
 BUSMOD bit = 1 (byte enable separated)

CS Area Wait Control Register (Note 2)  
 WAIT bit = 0010 (2 wait)  
 CWAIT bit = 0 (without CS wait)  
 SWAIT bit = 0 (without strobe wait)  
 RECOV bit = 0 (without recovery cycle)  
 IDLE bit = 0 (without idle cycle)



Note 1: For details about the Bus Mode Control Register, see Section 17.2.2, "Bus Mode Control Register."  
 Note 2: For details about the CS Area Wait Control Register, see Section 18.2.1, "CS Area Wait Control Registers."  
 Notes: • Circles in the above diagram denote the sampling timing.  
 • CLKOUT is not output.

**Figure 17.3.6 Read/Write Timing (for Access with Internal 2 and External 1 Wait States)**

## 17.4 Bus Arbitration

### (1) When the Bus Mode Control Register = "0"

When the input signal on the HREQ# pin is pulled "L" and the hold request is accepted, the microcomputer goes to a hold state and outputs a "L" from the HACK# pin. During hold state, all bus related pins are placed in the high-impedance state, allowing data to be transferred on the system bus. To exit the hold state and return to normal operating state, release the HREQ# signal back "H."

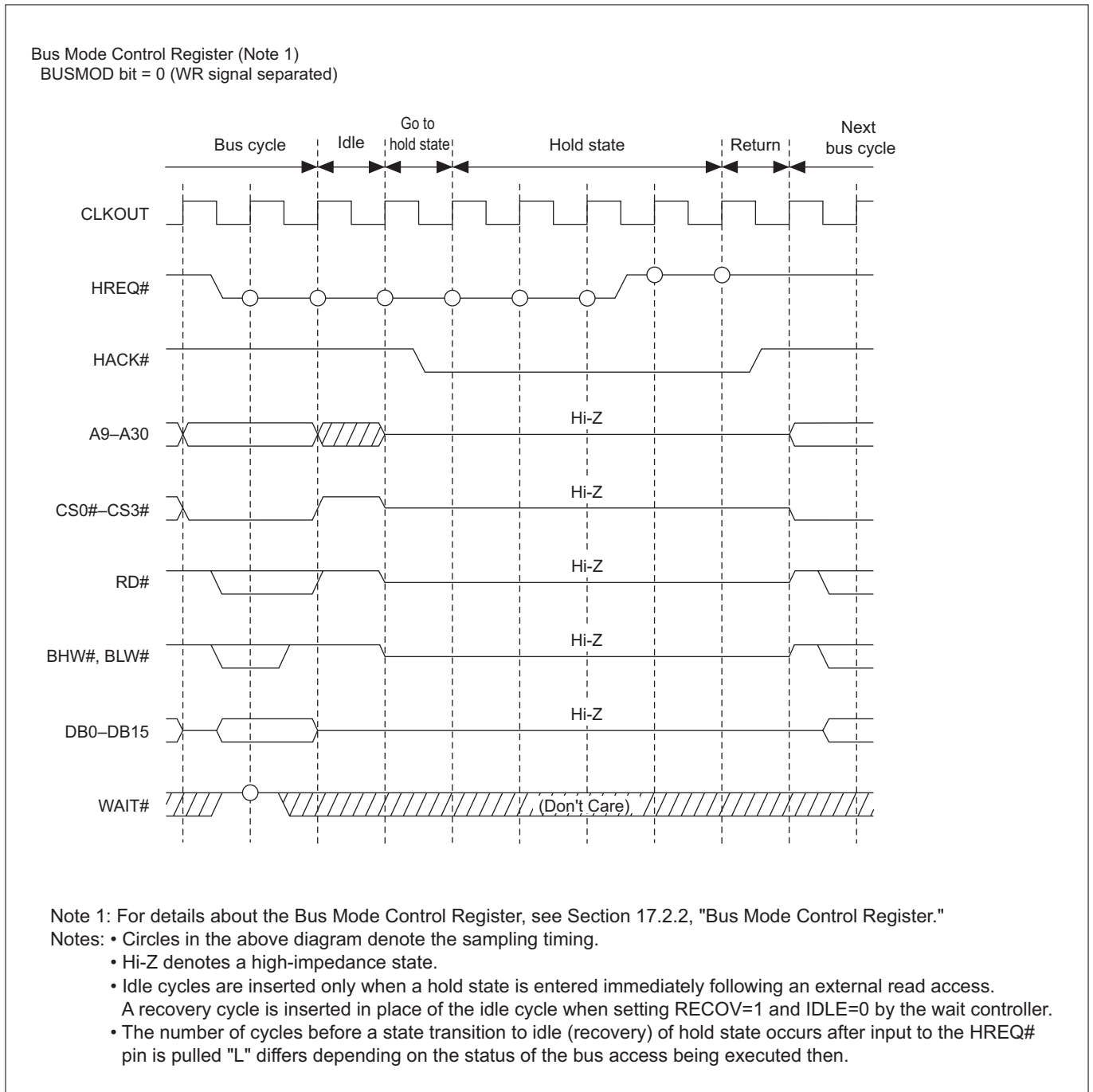


Figure 17.4.1 Bus Arbitration Timing

#### (2) When the Bus Mode Control Register = "1"

When the input signal on the HREQ# pin is pulled "L" and the hold request is accepted, the microcomputer goes to a hold state and outputs a "L" from the HACK# pin. During hold state, all bus related pins are placed in the high-impedance state, allowing data to be transferred on the system bus. To exit the hold state and return to normal operating state, release the HREQ# signal back "H."

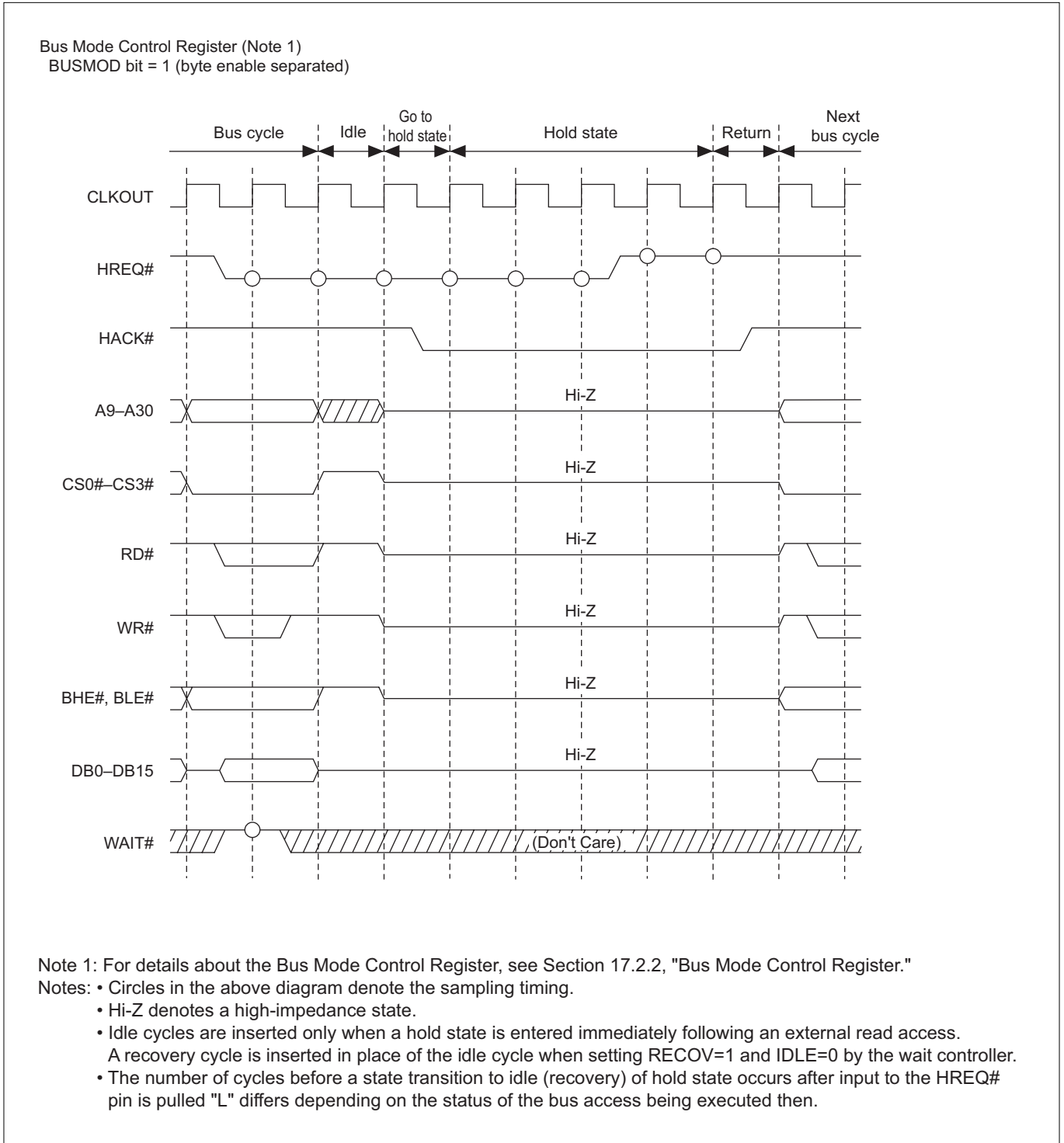


Figure 17.4.2 Bus Arbitration Timing

## 17.5 Typical Connection of External Extension Memory

### (1) When the Bus Mode Control Register = "0"

A typical memory connection when using external extension memory is shown in Figure 17.5.1. (External extension memory can only be used in external extension mode and processor mode.)

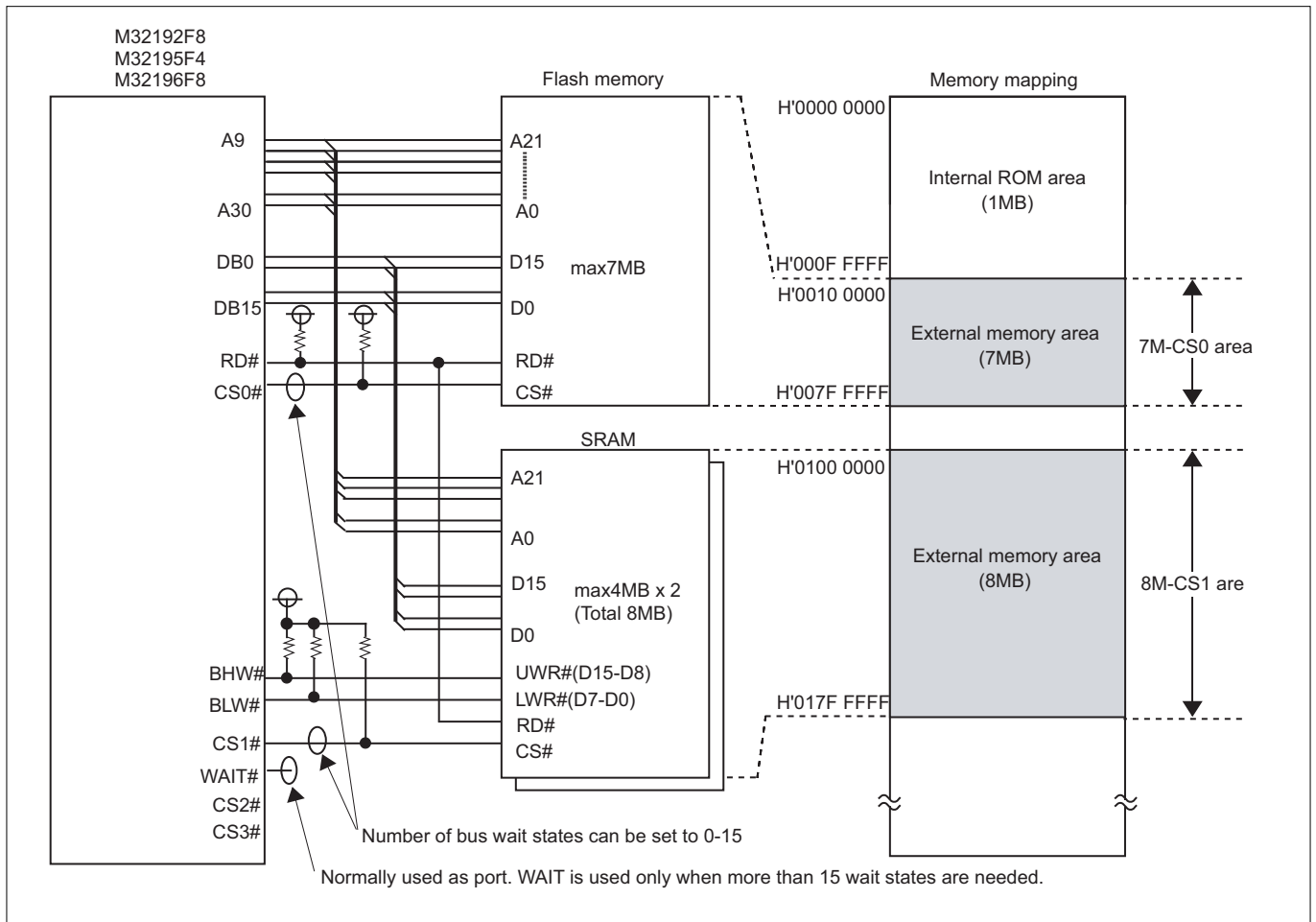
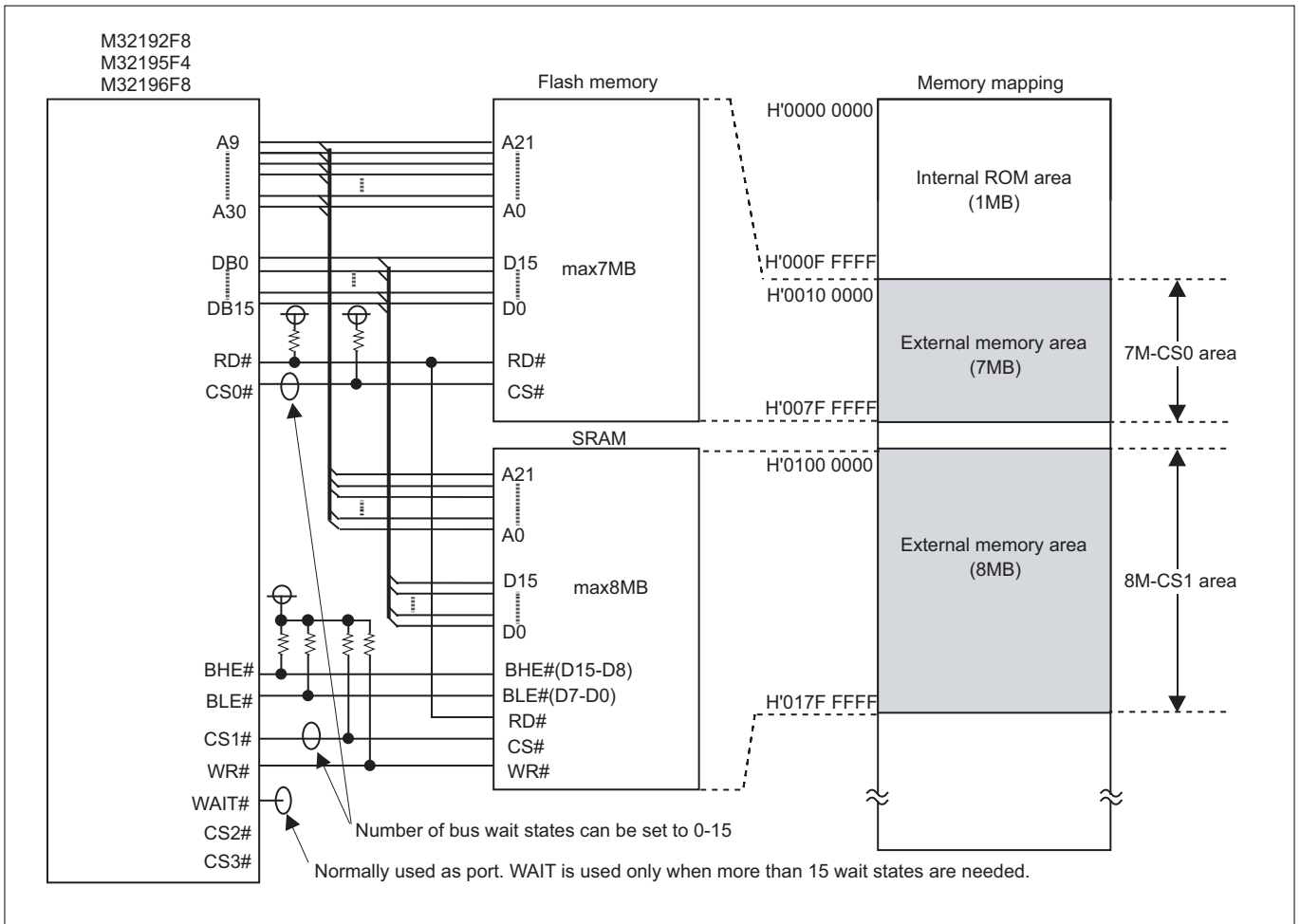


Figure 17.5.1 Typical Connection of External Extension Memory (when BUSMOD bit = "0")

- Notes:
- Address pin 0 is the MSB, and pin 31 is the LSB. (Pins 9-30 are output).
  - Data pin 0 is the MSB, and pin 15 is the LSB.
  - If external extension memory is connected to the system, the MSB and the LSB sides (endian format) should be taken into consideration when connecting each pin.

#### (2) When the Bus Mode Control Register = "1"

A typical memory connection when using external extension memory is shown in Figure 17.5.2. (External extension memory can only be used in external extension mode and processor mode.)



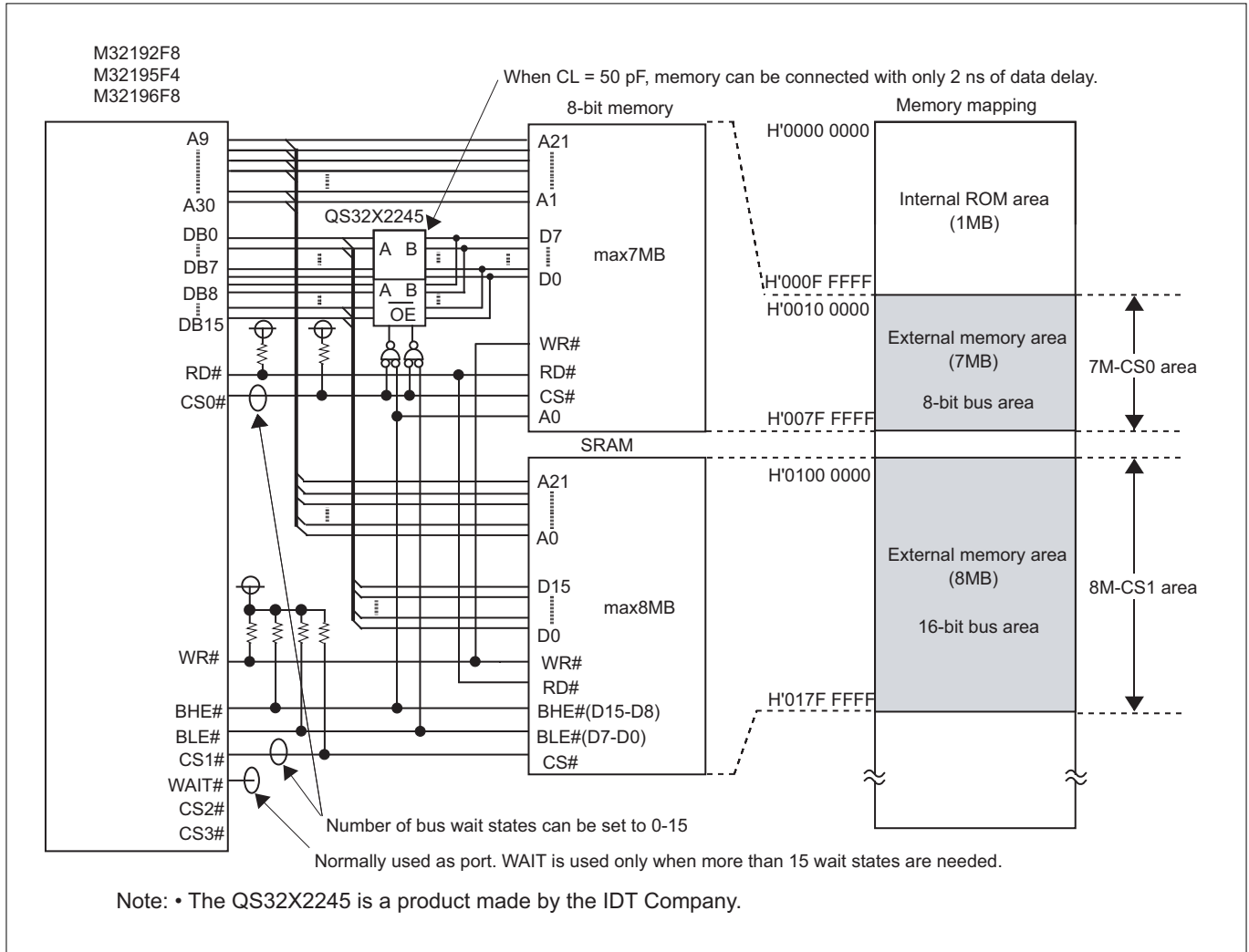
**Figure 17.5.2 Typical Connection of External Extension Memory (when BUSMOD bit = "1")**

- Notes:
- Address pin 0 is the MSB, and pin 31 is the LSB. (Pins 9-30 are output).
  - Data pin 0 is the MSB, and pin 15 is the LSB.
  - If external extension memory is connected to the system, the MSB and the LSB sides (endian format) should be taken into consideration when connecting each pin.



#### (3) When the Bus Mode Control Register = "1" using a combination of 8/16-bit data bus memories

The diagram below shows a typical connection of external extension memory, with an 8-bit data bus memory located in the CS0 area, and a 16-bit data bus memory located in the CS1 area. (External extension memory can only be used in external extension mode and processor mode.)



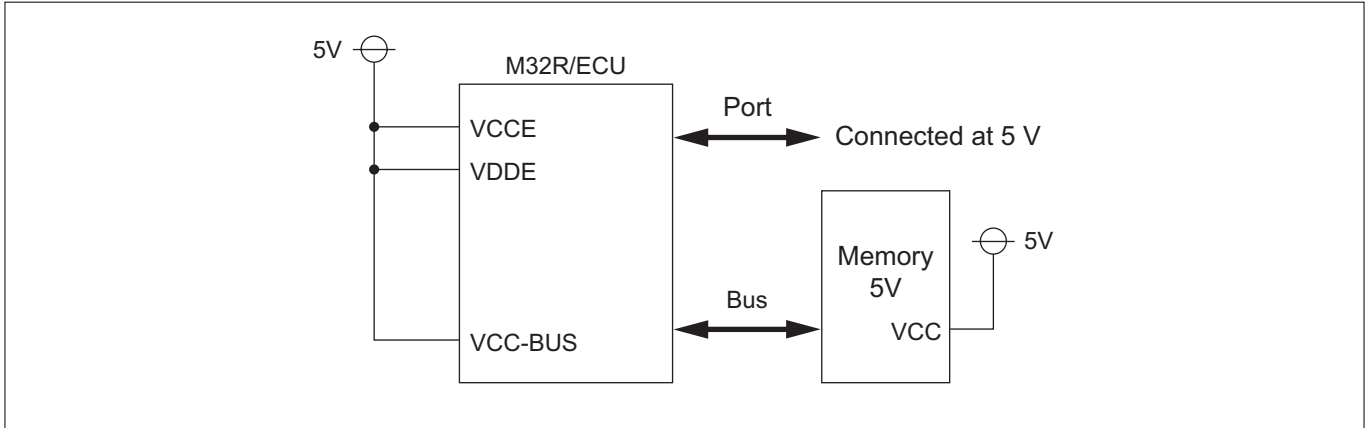
**Figure 17.5.3 Typical Connection of External Extension Memory (when BUSMOD bit = "1" using a combination of 8/16-Bit Memories)**

- Notes:
- Address pin 0 is the MSB, and pin 31 is the LSB. (Pins 9-30 are output).
  - Data pin 0 is the MSB, and pin 15 is the LSB.
  - If external extension memory is connected to the system, the MSB and the LSB sides (endian format) should be taken into consideration when connecting each pin.

#### 17.6 Example of Bus Voltage Settings Using VCC-BUS

##### (1) When both port and memory are connected at 5 V

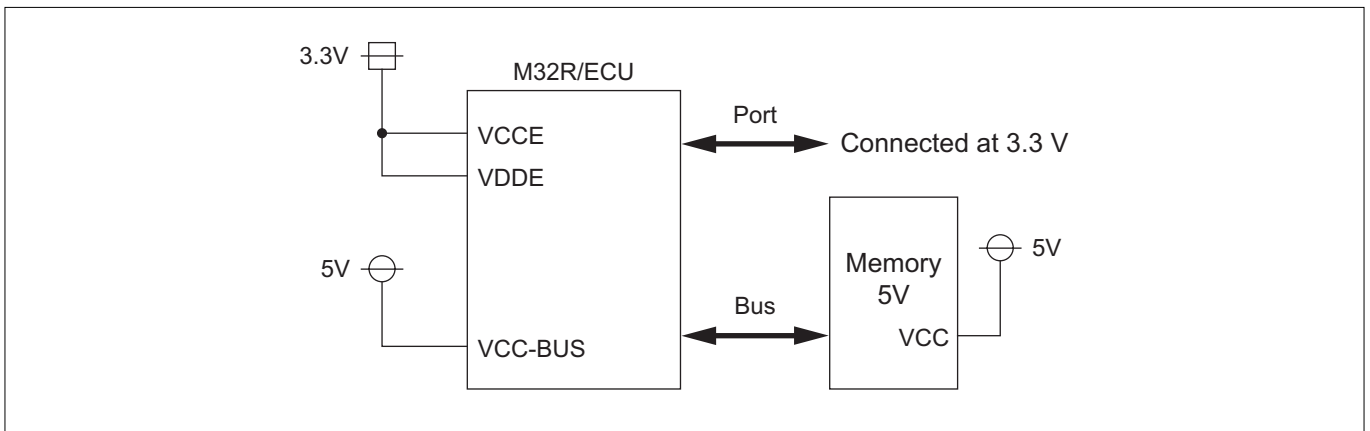
Ports and memory can be connected with external circuits via 5 V interfaces.



**Figure 17.6.1 When Both Port and Memory are Connected at 5 V**

##### (2) When ports and memory are connected at 3.3 V and 5 V, respectively

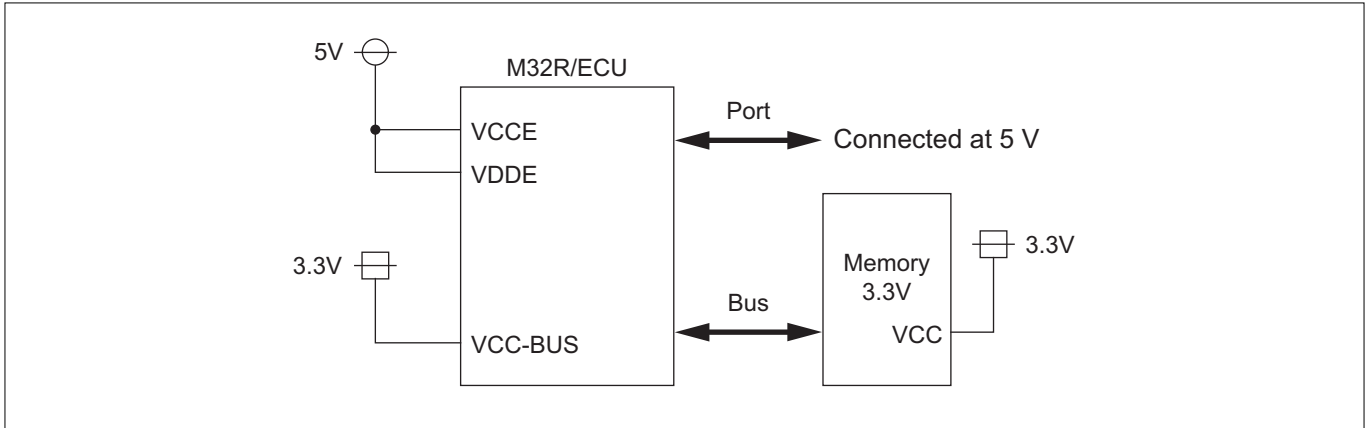
Ports and memory can be connected with external circuits via a 3.3 V interface directly as is and a 5 V interface, respectively.



**Figure 17.6.2 When Port and Memory are Connected at 3.3 V and 5 V, Respectively**

#### (3) When ports and memory are connected at 5 V and 3.3 V, respectively

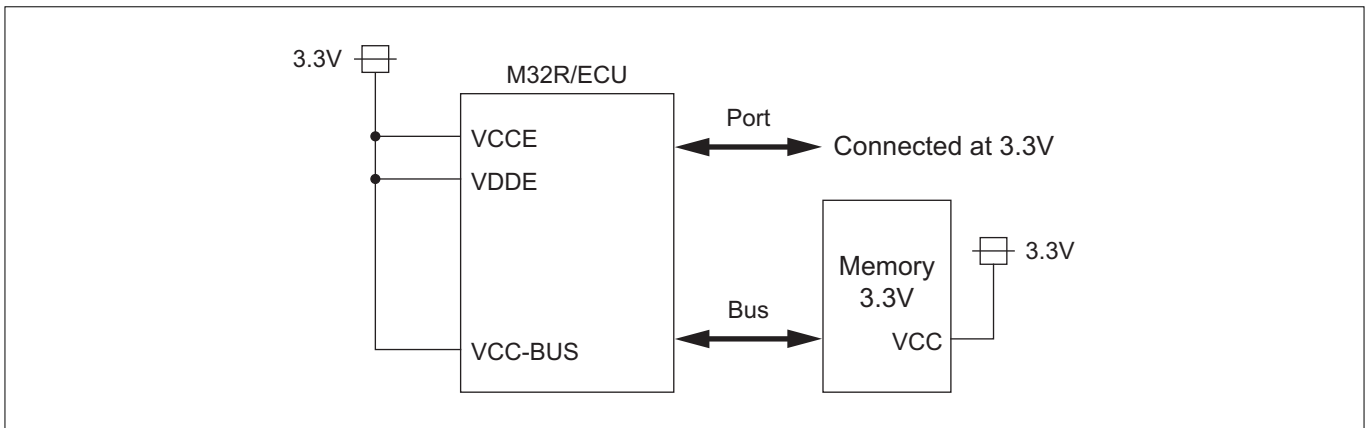
Ports and memory can be connected with external circuits via a 5 V interface directly as is and a 3.3 V interface, respectively.



**Figure 17.6.3 When Port and Memory are Connected at 5 V and 3.3 V, Respectively**

#### (4) When both port and memory are connected at 3.3 V

Ports and memory can be connected with external circuits via 3.3 V interfaces.



**Figure 17.6.4 When Both Port and Memory are Connected at 3.3 V**

This page is blank for reasons of layout.

## **CHAPTER 18**

---

# **WAIT CONTROLLER**

- 18.1 Outline of the Wait Controller
- 18.2 Wait Controller Related Registers
- 18.3 Typical Operation of the Wait Controller

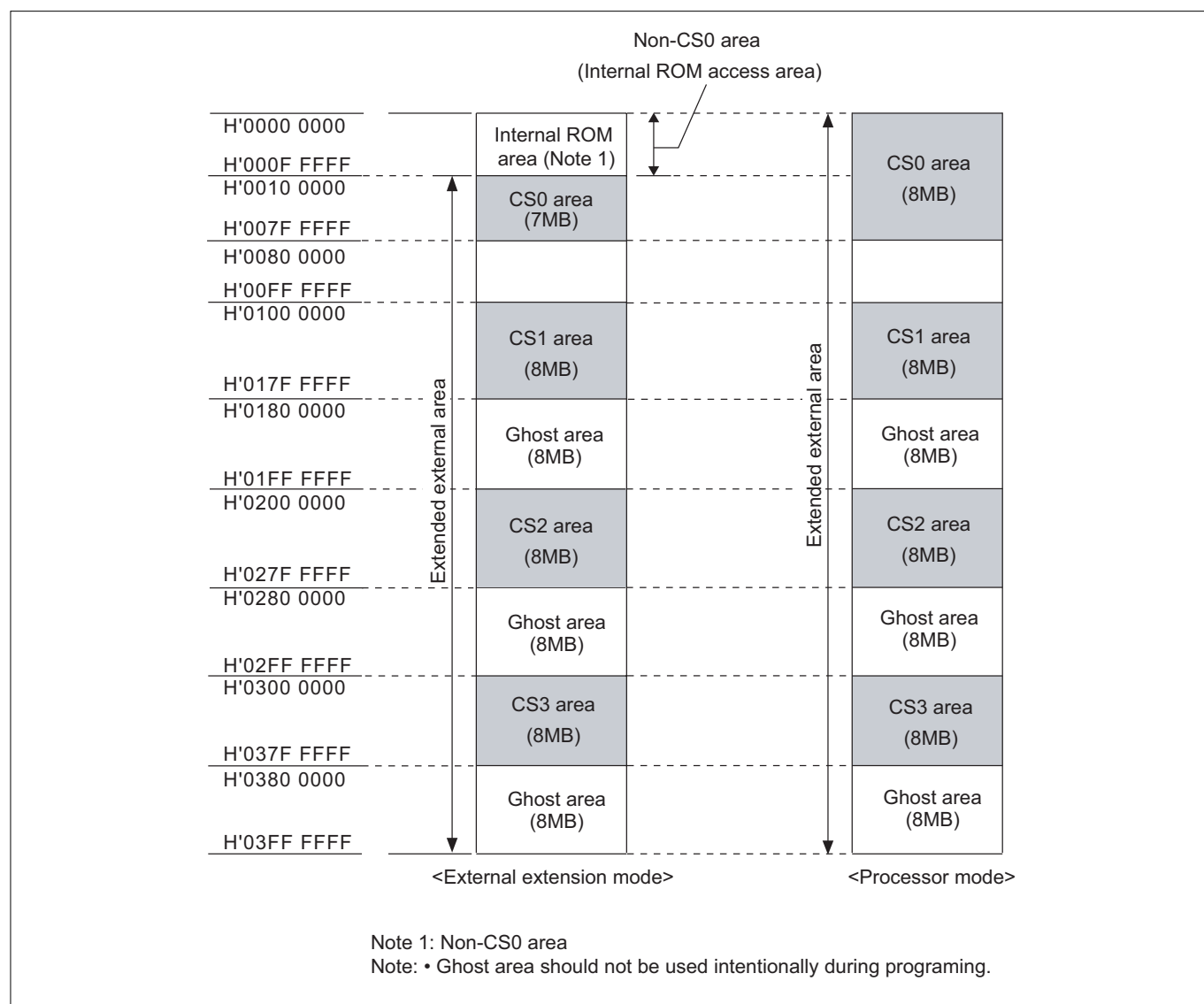
#### 18.1 Outline of the Wait Controller

The Wait Controller controls the number of wait states inserted in bus cycles when accessing an external extension area. The Wait Controller is outlined in the table below.

**Table 18.1.1 Outline of the Wait Controller**

Item	Description
Target space	Control is applied to the following address spaces depending on operation mode: Single-chip mode: No target space (Settings of the Wait Controller have no effect) External extension mode: CS0 area (7 Mbytes), CS1 area (8 Mbytes), CS2 area (8 Mbytes), CS3 area (8 Mbytes) Processor mode: CS0 area (8 Mbytes), CS1 area (8 Mbytes), CS2 area (8 Mbytes), CS3 area (8 Mbytes)
Number of wait states that can be inserted	0–15 wait states set by software + any number of wait states set from the WAIT# pin

During external extension and processor modes, four chip select signals (CS0# to CS3#) are output, each corresponding to one of the four external extension areas referred to as CS0 through CS3.



**Figure 18.1.1 CS0–CS3 Area Address Map**

When accessing the external extension area, the Wait Controller controls the number of wait states inserted in bus cycles based on the number of wait states set by software and the input signal entered from the WAIT# pin.

The number of wait states that can be controlled in software is 0 to 15.

When the input signal on the WAIT# pin is sampled "L" in the last cycle of internal wait state, the wait state is extended as long as the WAIT# input signal is held "L." Then when the WAIT# input signal is released back "H." the wait state is terminated and the next new bus cycle is entered into.

**Table 18.1.2 Number of Wait States that Can Be Set by the Wait Controller**

External extension Area	Address	Number of Wait States Inserted
CS0 area	H'0010 0000 to H'007F FFFF (external extension mode) H'0000 0000 to H'007F FFFF (processor mode)	Zero to 15 wait states set by software + any number of wait states entered from the WAIT# pin (However, software settings have priority.)
CS1 area (Note 1)	H'0100 0000 to H'017F FFFF (external extension and processor modes)	Zero to 15 wait states set by software + any number of wait states entered from the WAIT# pin (However, software settings have priority.)
CS2 area (Note 2)	H'0200 0000 to H'027F FFFF (external extension and processor modes)	Zero to 15 wait states set by software + any number of wait states entered from the WAIT# pin (However, software settings have priority.)
CS3 area (Note 3)	H'0300 0000 to H'037F FFFF (external extension and processor modes)	Zero to 15 wait states set by software + any number of wait states entered from the WAIT# pin (However, software settings have priority.)

Note 1: A ghost (8 Mbytes) of the CS1 area will appear in the H'0180 0000 to H'01FF FFFF area.

Note 2: A ghost (8 Mbytes) of the CS2 area will appear in the H'0280 0000 to H'02FF FFFF area.

Note 3: A ghost (8 Mbytes) of the CS3 area will appear in the H'0380 0000 to H'03FF FFFF area.

## 18.2 Wait Controller Related Registers

Shown below is a Wait Controller related register map.

### Wait Controller Related Register Map

Address	+0 address		+1 address		See pages
	b0	b7	b8	b15	
H'0080 0180	CS0 Area Wait Control Register (CS0WTCR)		CS1 Area Wait Control Register (CS1WTCR)		18-4
H'0080 0182	CS2 Area Wait Control Register (CS2WTCR)		CS3 Area Wait Control Register (CS3WTCR)		18-4
H'0080 01A2	Flash E/W Wait Select Register (FWAIT)		(Use inhibited area)		18-6

### 18.2.1 CS Area Wait Control Registers

CS0 Area Wait Control Register (CS0WTCR)

<Address: H'0080 0180>

CS1 Area Wait Control Register (CS1WTCR)

<Address: H'0080 0181>

CS2 Area Wait Control Register (CS2WTCR)

<Address: H'0080 0182>

CS3 Area Wait Control Register (CS3WTCR)

<Address: H'0080 0183>

b0(b8)	1	2	3	4	5	6	b7(b15)
	WAITn			CWAITn	SWAITn	RECOVn	IDLEn
	1	1	1	1	1	1	1

<Upon exiting reset: H'FF>

b	Bit Name	Function	R	W
0-3	WAIT	0000: 0 wait state (Note 1)	R	W
(8-11)	Internal wait states select bit	0001: 1 wait state     1111: 15 wait state		
4	CWAIT	0: No CS wait	R	W
(12)	CS signal wait bit	1: CS wait added		
5	SWAIT	0: No strobe wait	R	W
(13)	Strobe signal wait bit	1: Strobe wait added		
6	RECOV	0: No recovery cycle	R	W
(14)	Recovery cycle addition bit	1: Recovery cycle added		
7	IDLE	0: No post-read idle cycle	R	W
(15)	Post-read idle cycle addition bit	1: Post-read idle cycle added		

Note 1: When zero wait state is selected, wait states inserted by external WAIT# input are not accepted. Also, when the CLKOUT Select Register (CLKOUTSEL) CLKOSEL bit is set to "1" (i.e., BCLK is selected as CLKOUT output), selecting 0 wait state is prohibited whether use CS0 to CS3 or not.



The operation is not guaranteed if the settings listed in the Table 18.2.1 are selected.

**Table 18.2.1 List of Prohibited Settings**

CLKOSEL	WAIT	CWAIT	SWAIT	RECOV	IDLE
0	0000	1	–	–	–
0	0000	–	1	–	–
0	0000	–	–	1	–
0	0000	–	–	–	1
0	0001	1	1	–	–
1	0000	–	–	–	–
1	0001	1	–	–	–
1	0001	–	1	–	–

Note: • " – " = Don't Care

If a read cycle is followed immediately by a write cycle, one idle cycle is inserted unless RECOV bit = 1 and IDLE bit = 0. Table 18.2.2 shows the relationship between RECOV bit and IDLE bit settings and the number of idle cycles inserted after the bus cycle.

**Table 18.2.2 RECOV Bit and IDLE Bit Settings and the Number of Idle Cycles Inserted after Bus Cycle**

RECOV	IDLE	Read (Followed by Write)	Read (Followed by Read)	Write
0	0	1	0 (Note 1)	0
0	1	1	1	0
1	0	0	0	0
1	1	1	1	0

Note 1: The number of cycles inserted when instruction fetch access occurs back-to-back, or operand access is performed successively by a word (32-bit) access. In other cases (if operand access is performed successively, instruction fetch access is followed by operand access or operand access is followed by instruction fetch access), a 1-cycle idle cycle is inserted.

Note: • Under each of the above conditions, no recovery cycle is inserted when RECOV bit = 0, and one recovery cycle is inserted when RECOV bit = 1.

## 18.2.2 Flash E/W Wait Select Register

Flash E/W Wait Select Register (FWAIT)

&lt;Address: H'0080 01A2&gt;

b0	1	2	3	4	5	6	b7
0	0	0	0	0	0	0	FEWWAIT 0

&lt;Upon exiting reset: H'00&gt;

b	Bit Name	Function	R	W
0-6	No function assigned. Fix to "0."		0	0
7	FEWWAIT	0: 9WAIT	R	0
	Flash E/W internal wait states select bit	1: 4WAIT		

**(1) FEWWAIT (Flash E/W Internal Wait States Select) bit (Bits 7)**

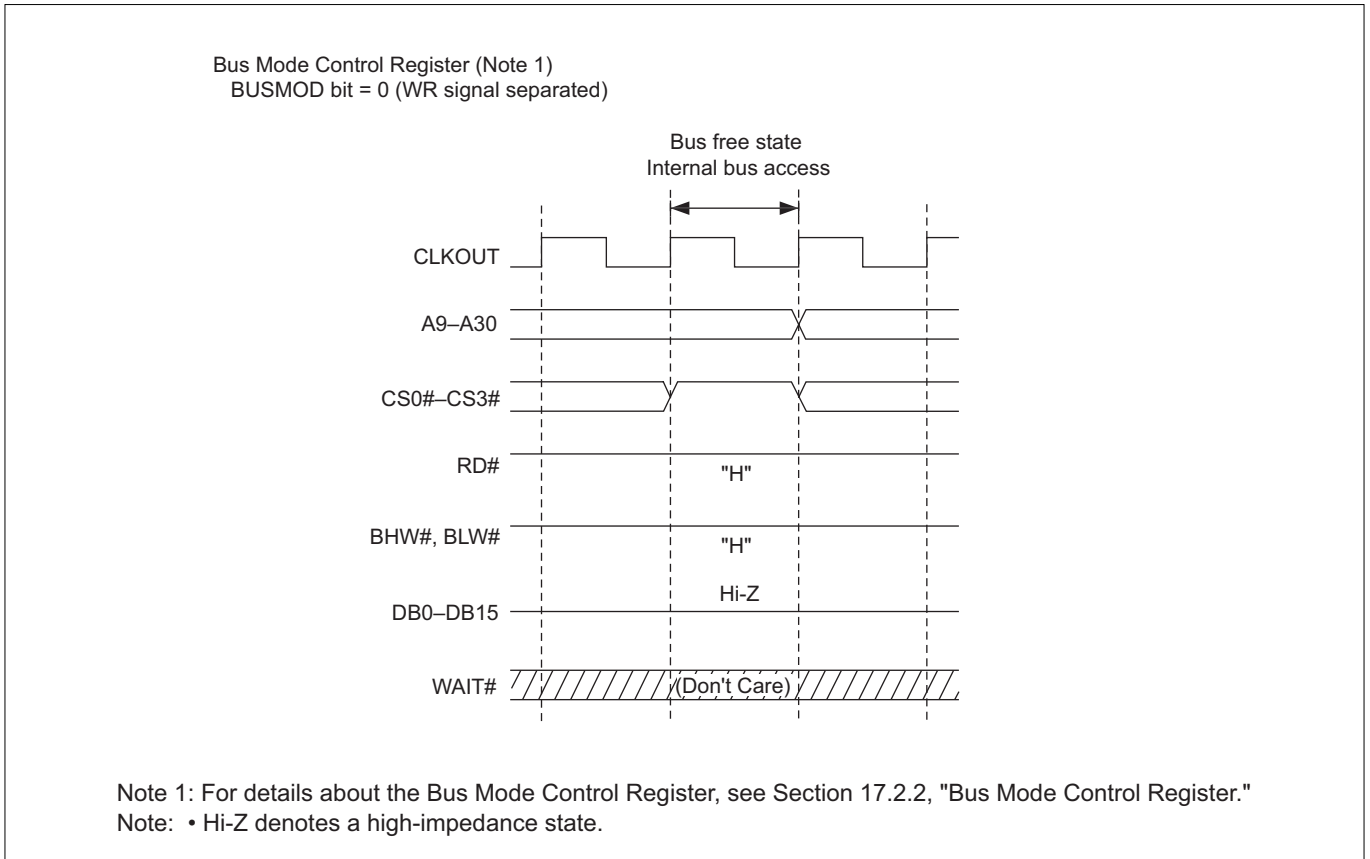
This bit selects the number of wait states to be inserted in internal cycles during flash E/W access. Always be sure to set this bit to "0" before executing flash E/W operation.

### 18.3 Typical Operation of the Wait Controller

The following shows a typical operation of the Wait Controller. The Wait Controller can control bus access in zero to 15 cycles. If more access cycles than that are needed, use the WAIT function in combination with the Wait Controller.

#### (1) When the Bus Mode Control Register = 0

External read/write operations are performed using the address bus, data bus and the signals CS0#–CS3#, RD#, BHW#, BLW#, WAIT#, CLKOUT and BCLK.

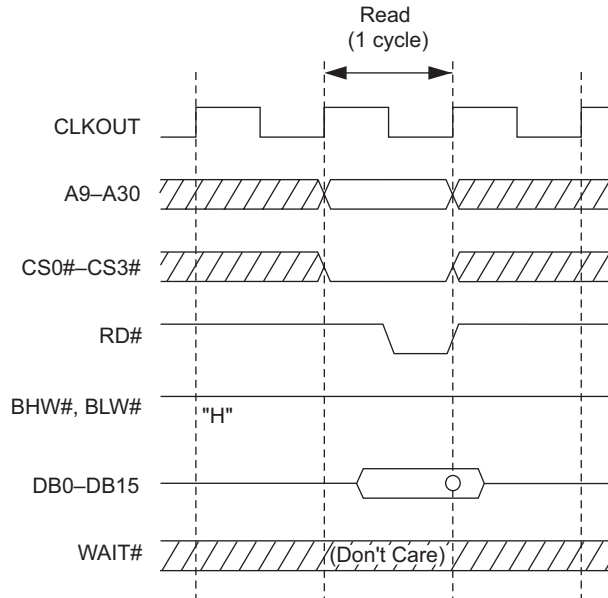


**Figure 18.3.1 Internal Bus Access during Bus Free State**

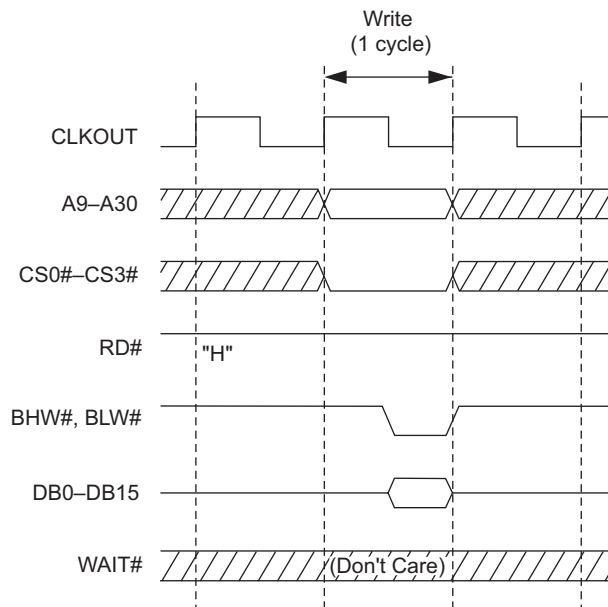
Bus Mode Control Register (Note 1)  
 BUSMOD bit = 0 (WR signal separated)

CS Area Wait Control Register (Note 2)  
 WAIT bit = 0000 (zero wait)  
 CWAIT bit = 0 (without CS wait)  
 SWAIT bit = 0 (without strobe wait)  
 RECOV bit = 0 (without recovery cycle)  
 IDLE bit = 0 (without idle cycle)

Read



Write



Note 1: For details about the Bus Mode Control Register, see Section 17.2.2, "Bus Mode Control Register."

Note 2: For details about the CS Area Wait Control Register, see Section 18.2.1, "CS Area Wait Control Registers."

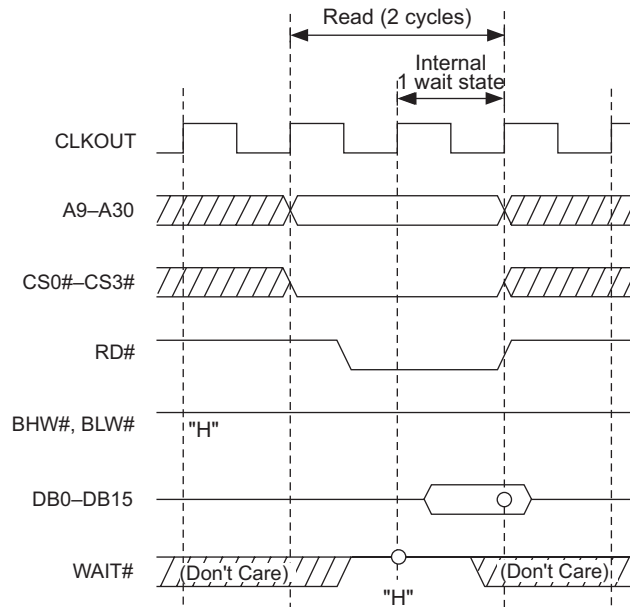
Note: • When zero wait state is selected, wait states inserted by WAIT# are not accepted.

Figure 18.3.2 Read/Write Timing (for Zero Wait Access)

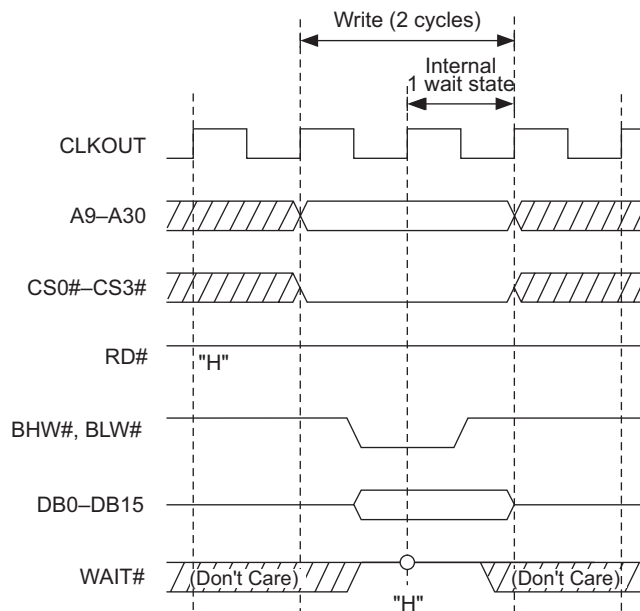
Bus Mode Control Register (Note 1)  
 BUSMOD bit = 0 (WR signal separated)

CS Area Wait Control Register (Note 2)  
 WAIT bit = 0001 (1 wait)  
 CWAIT bit = 0 (without CS wait)  
 SWAIT bit = 0 (without strobe wait)  
 RECOV bit = 0 (without recovery cycle)  
 IDLE bit = 0 (without idle cycle)

Read



Write



Note 1: For details about the Bus Mode Control Register, see Section 17.2.2, "Bus Mode Control Register."

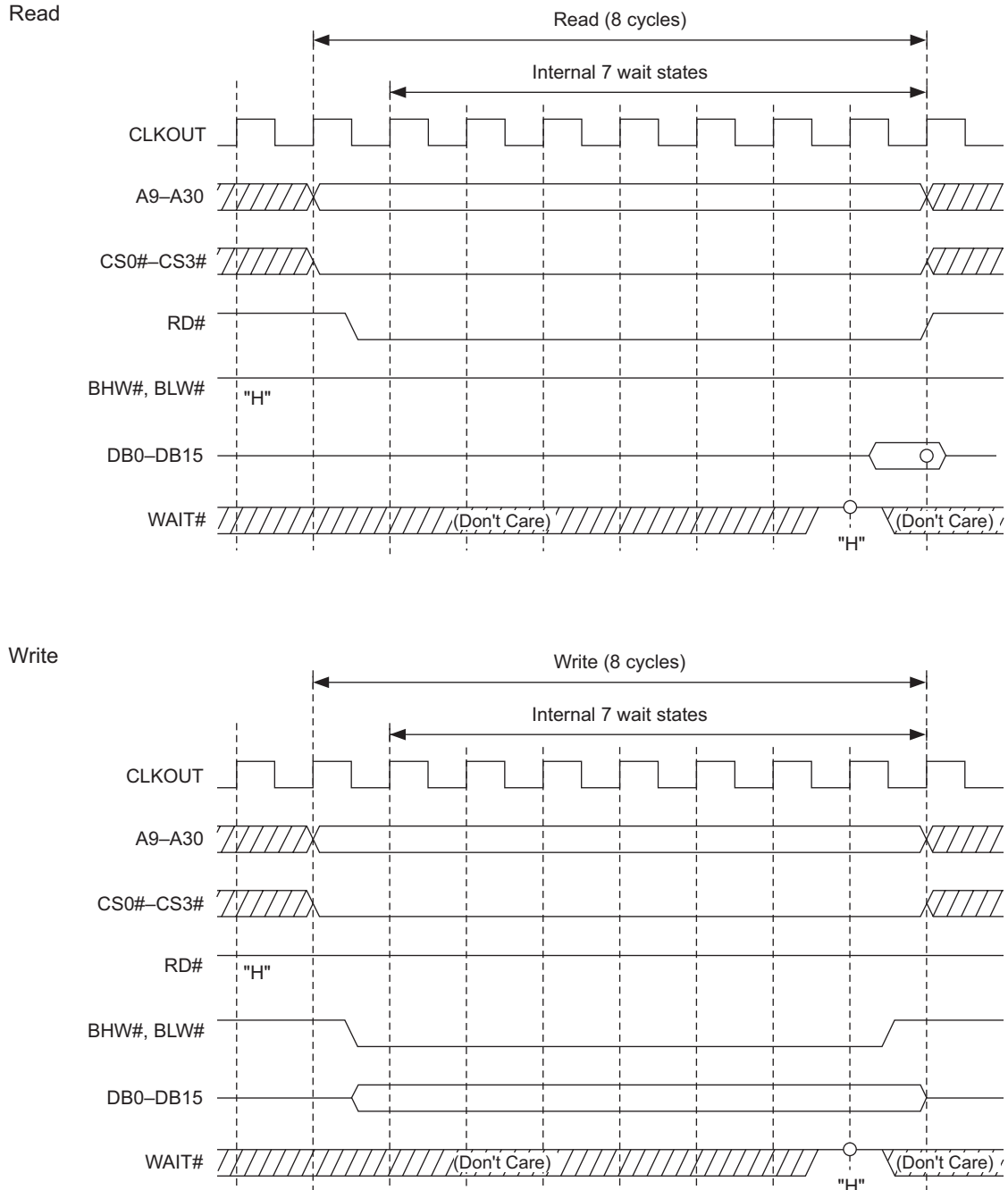
Note 2: For details about the CS Area Wait Control Register, see Section 18.2.1, "CS Area Wait Control Registers."

Note: • Circles in the above diagram indicate the sampling timing.

**Figure 18.3.3 Read/Write Timing (for Access with Internal 1 Wait State)**

Bus Mode Control Register (Note 1)  
 BUSMOD bit = 0 (WR signal separated)

CS Area Wait Control Register (Note 2)  
 WAIT bit = 0111 (7 wait)  
 CWAIT bit = 0 (without CS wait)  
 SWAIT bit = 0 (without strobe wait)  
 RECOV bit = 0 (without recovery cycle)  
 IDLE bit = 0 (without idle cycle)



Note 1: For details about the Bus Mode Control Register, see Section 17.2.2, "Bus Mode Control Register."

Note 2: For details about the CS Area Wait Control Register, see Section 18.2.1, "CS Area Wait Control Registers."

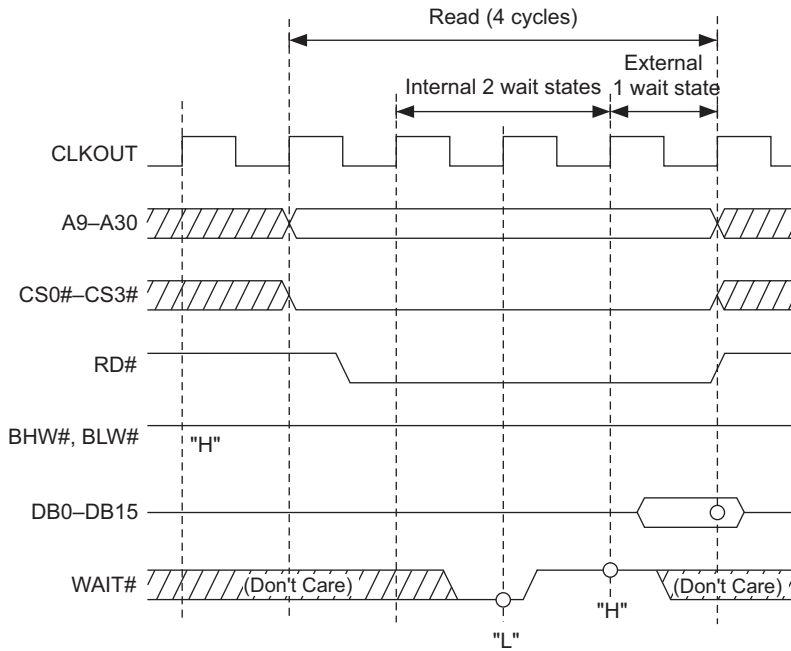
Note: • Circles in the above diagram indicate the sampling timing.

**Figure 18.3.4 Read/Write Timing (for Access with Internal 7 Wait States)**

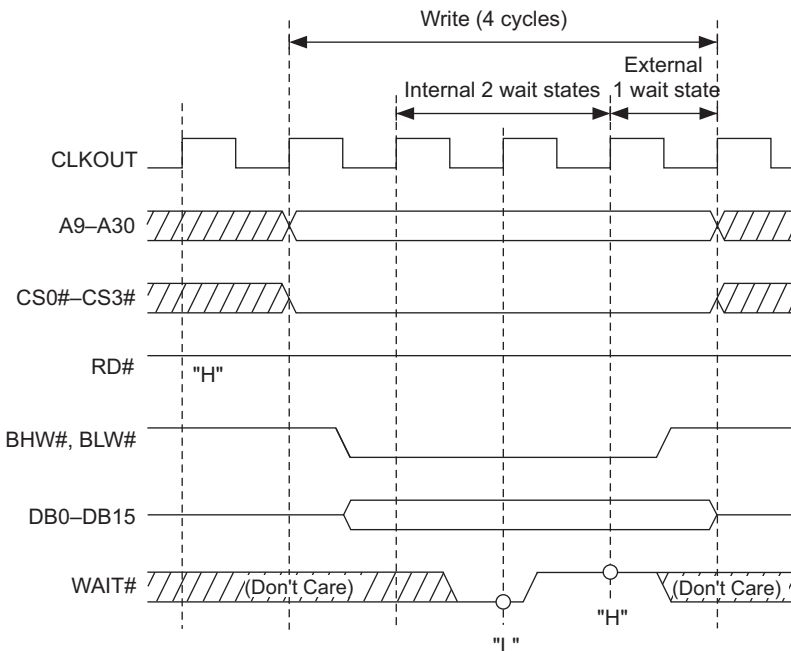
Bus Mode Control Register (Note 1)  
 BUSMOD bit = 0 (WR signal separated)

CS Area Wait Control Register (Note 2)  
 WAIT bit = 0010 (2 wait)  
 CWAIT bit = 0 (without CS wait)  
 SWAIT bit = 0 (without strobe wait)  
 RECOV bit = 0 (without recovery cycle)  
 IDLE bit = 0 (without idle cycle)

Read



Write



Note 1: For details about the Bus Mode Control Register, see Section 17.2.2, "Bus Mode Control Register."

Note 2: For details about the CS Area Wait Control Register, see Section 18.2.1, "CS Area Wait Control Registers."

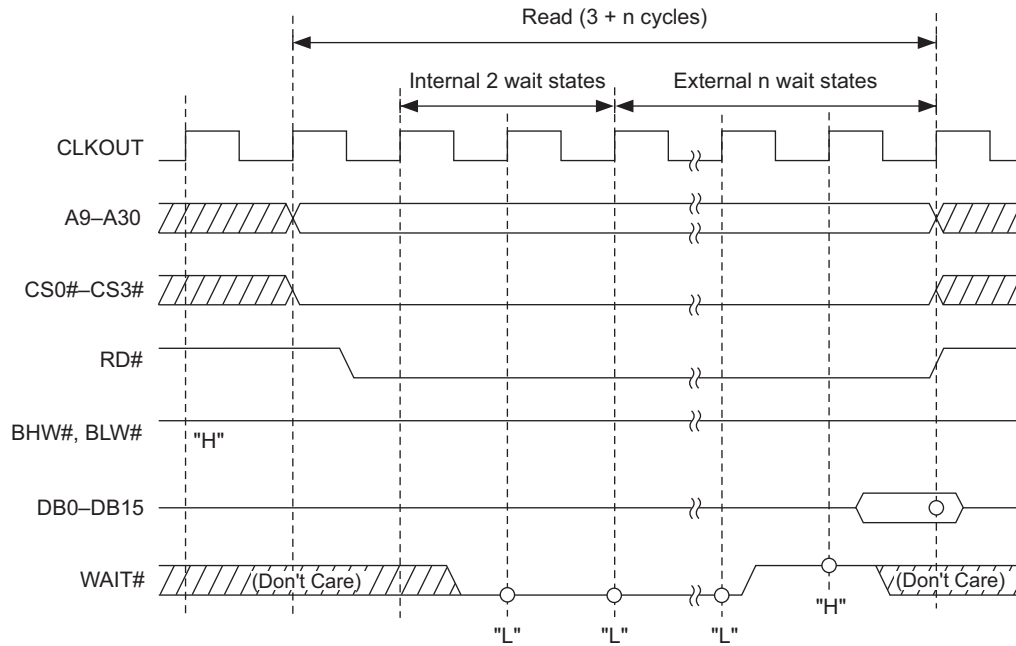
Note: • Circles in the above diagram indicate the sampling timing.

**Figure 18.3.5 Read/Write Timing (for Access with Internal 2 and External 1 Wait States)**

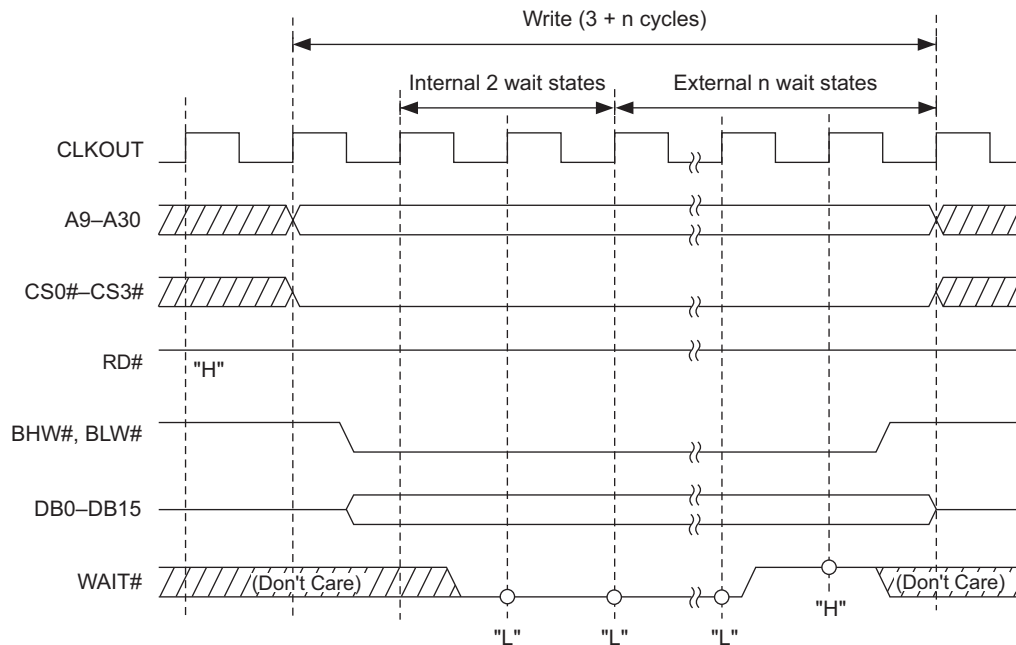
Bus Mode Control Register (Note 1)  
 BUSMOD bit = 0 (WR signal separated)

CS Area Wait Control Register (Note 2)  
 WAIT bit = 0010 (2 wait)  
 CWAIT bit = 0 (without CS wait)  
 SWAIT bit = 0 (without strobe wait)  
 RECOV bit = 0 (without recovery cycle)  
 IDLE bit = 0 (without idle cycle)

Read



Write



Note 1: For details about the Bus Mode Control Register, see Section 17.2.2, "Bus Mode Control Register."

Note 2: For details about the CS Area Wait Control Register, see Section 18.2.1, "CS Area Wait Control Registers."

Note: • Circles in the above diagram indicate the sampling timing.

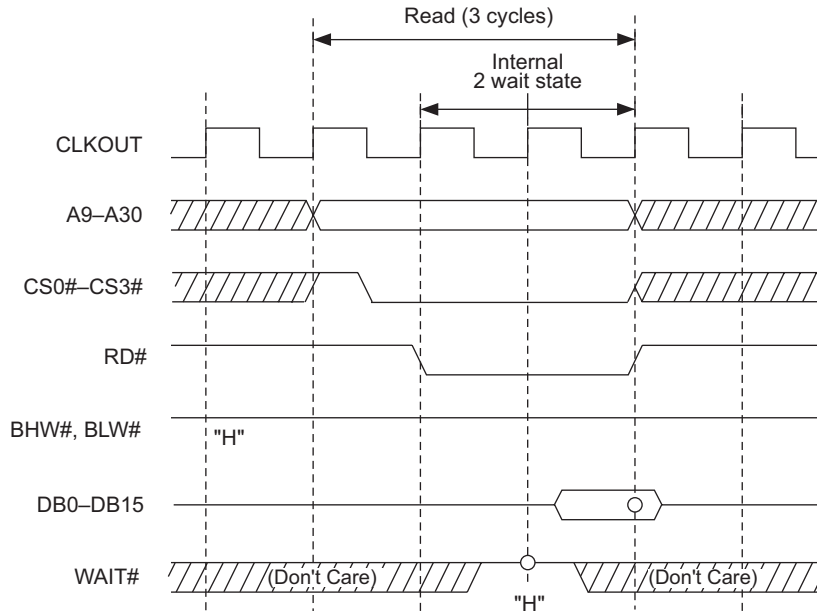
**Figure 18.3.6 Read/Write Timing (for Access with Internal 2 and External n Wait States)**



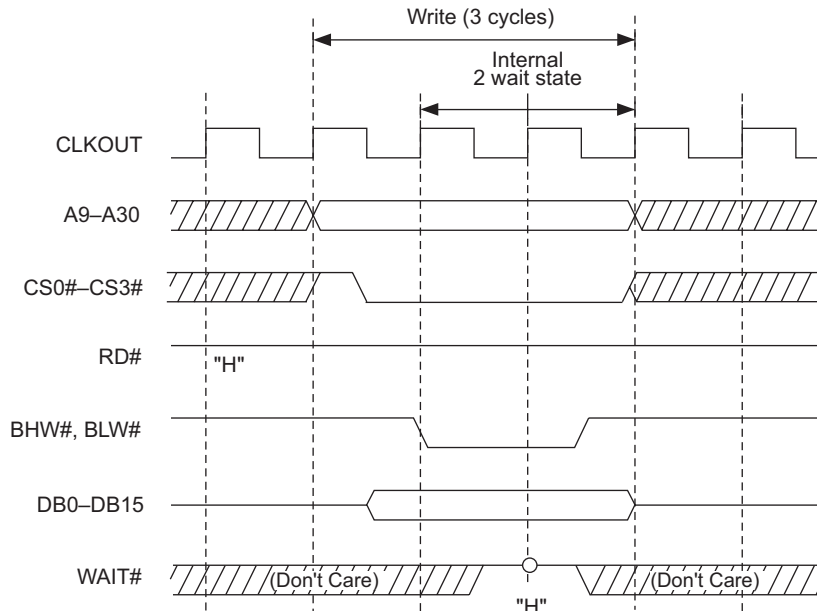
Bus Mode Control Register (Note 1)  
 BUSMOD bit = 0 (WR signal separated)

CS Area Wait Control Register (Note 2)  
 WAIT bit = 0010 (2 wait)  
 CWAIT bit = 1 (with CS wait)  
 SWAIT bit = 0 (without strobe wait)  
 RECOV bit = 0 (without recovery cycle)  
 IDLE bit = 0 (without idle cycle)

Read



Write



Note 1: For details about the Bus Mode Control Register, see Section 17.2.2, "Bus Mode Control Register."

Note 2: For details about the CS Area Wait Control Register, see Section 18.2.1, "CS Area Wait Control Registers."

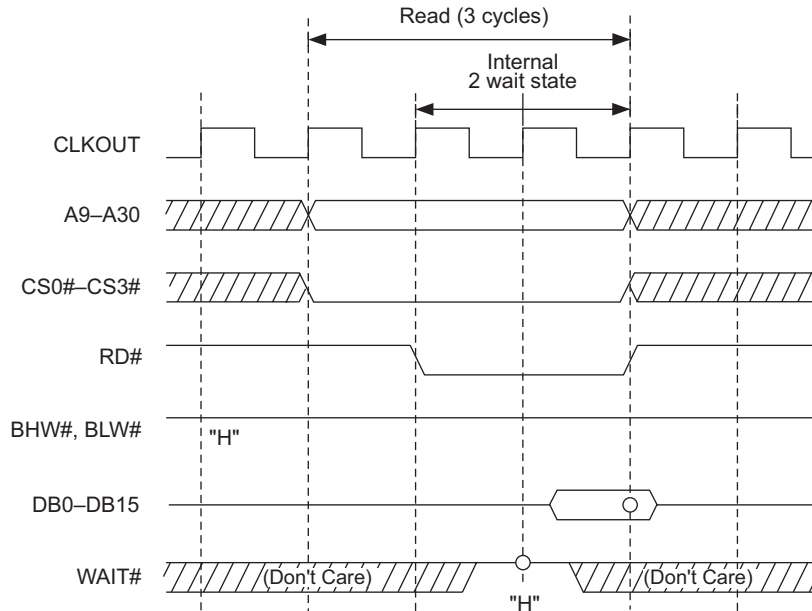
Note: • Circles in the above diagram indicate the sampling timing.

**Figure 18.3.7 Read/Write Timing (for Access with Internal 2 Wait State + CS Wait)**

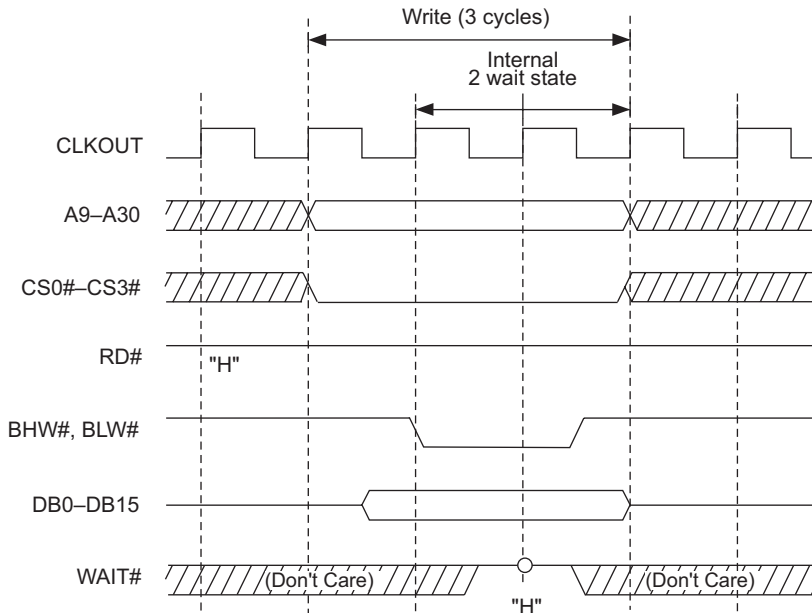
Bus Mode Control Register (Note 1)  
 BUSMOD bit = 0 (WR signal separated)

CS Area Wait Control Register (Note 2)  
 WAIT bit = 0010 (2 wait)  
 CWAIT bit = 0 (without CS wait)  
 SWAIT bit = 1 (with strobe wait)  
 RECOV bit = 0 (without recovery cycle)  
 IDLE bit = 0 (without idle cycle)

Read



Write



Note 1: For details about the Bus Mode Control Register, see Section 17.2.2, "Bus Mode Control Register."

Note 2: For details about the CS Area Wait Control Register, see Section 18.2.1, "CS Area Wait Control Registers."

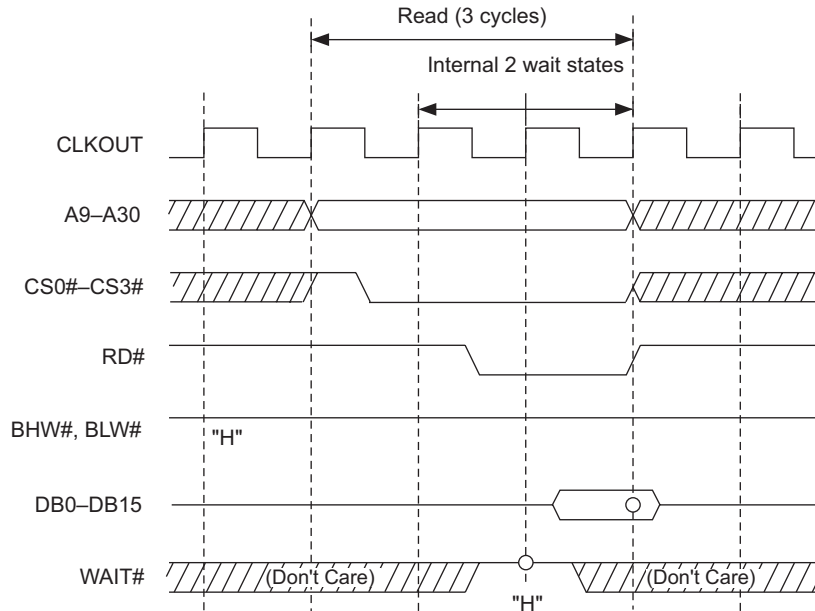
Note: • Circles in the above diagram indicate the sampling timing.

**Figure 18.3.8 Read/Write Timing (for Access with Internal 2 Wait State + Strobe Wait)**

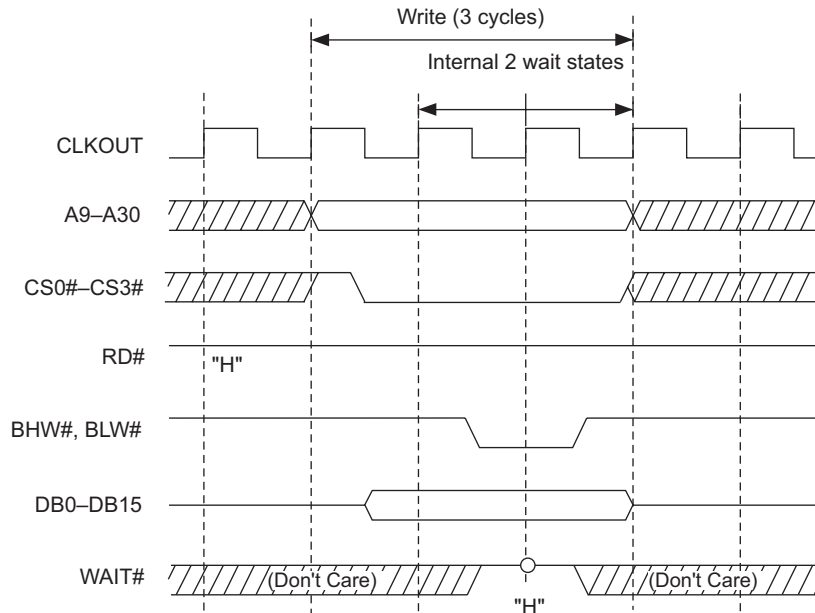
Bus Mode Control Register (Note 1)  
 BUSMOD bit = 0 (WR signal separated)

CS Area Wait Control Register (Note 2)  
 WAIT bit = 0010 (2 wait)  
 CWAIT bit = 1 (with CS wait)  
 SWAIT bit = 1 (with strobe wait)  
 RECOV bit = 0 (without recovery cycle)  
 IDLE bit = 0 (without idle cycle)

Read



Write



Note 1: For details about the Bus Mode Control Register, see Section 17.2.2, "Bus Mode Control Register."

Note 2: For details about the CS Area Wait Control Register, see Section 18.2.1, "CS Area Wait Control Registers."

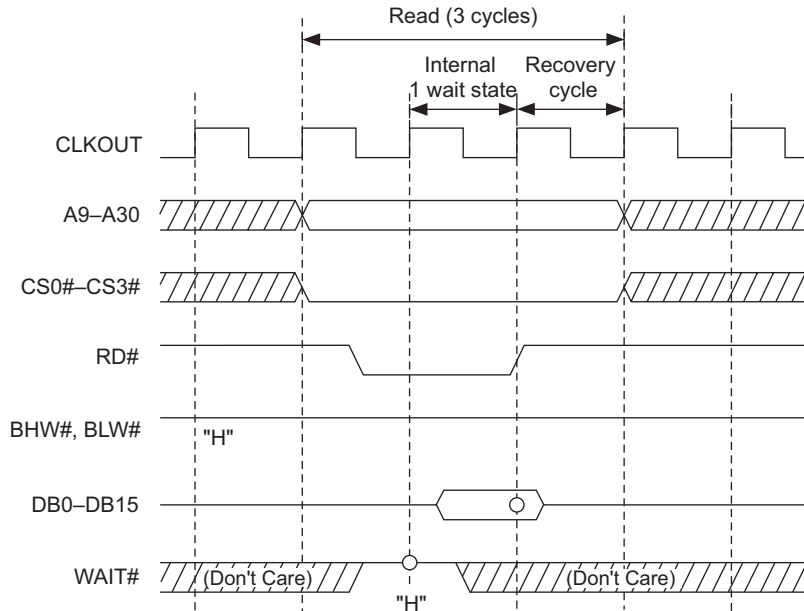
Note: • Circles in the above diagram indicate the sampling timing.

Figure 18.3.9 Read/Write Timing (for Access with Internal 2 Wait States + CS/Strobe Wait)

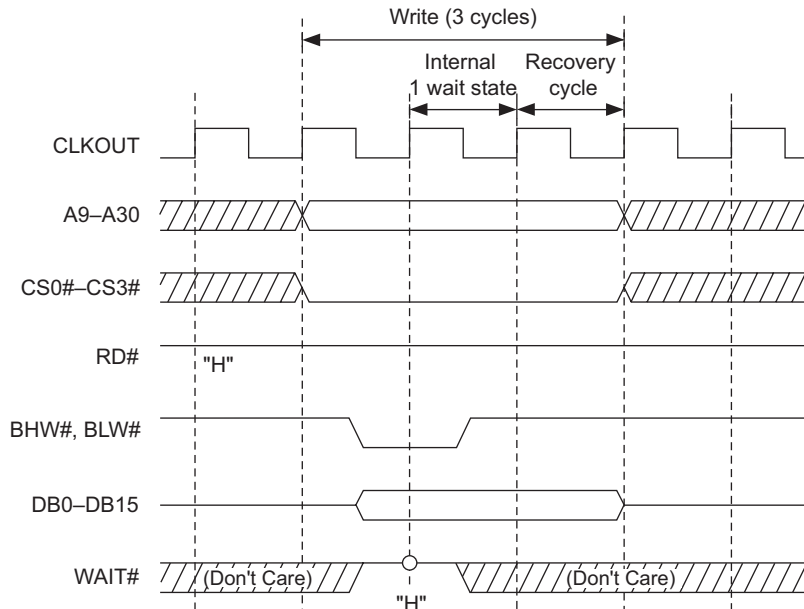
Bus Mode Control Register (Note 1)  
 BUSMOD bit = 0 (WR signal separated)

CS Area Wait Control Register (Note 2)  
 WAIT bit = 0001 (1 wait)  
 CWAIT bit = 0 (without CS wait)  
 SWAIT bit = 0 (without strobe wait)  
 RECOV bit = 1 (with recovery cycle)  
 IDLE bit = 0 (without idle cycle)

Read



Write



Note 1: For details about the Bus Mode Control Register, see Section 17.2.2, "Bus Mode Control Register."

Note 2: For details about the CS Area Wait Control Register, see Section 18.2.1, "CS Area Wait Control Registers."

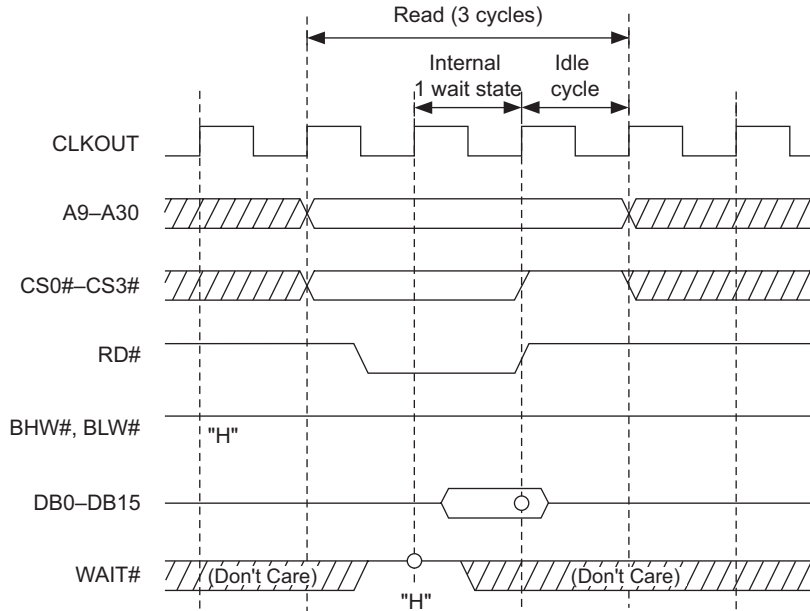
Note: • Circles in the above diagram indicate the sampling timing.

**Figure 18.3.10 Read/Write Timing (Internal 1 Wait State + Recovery Cycle Added)**

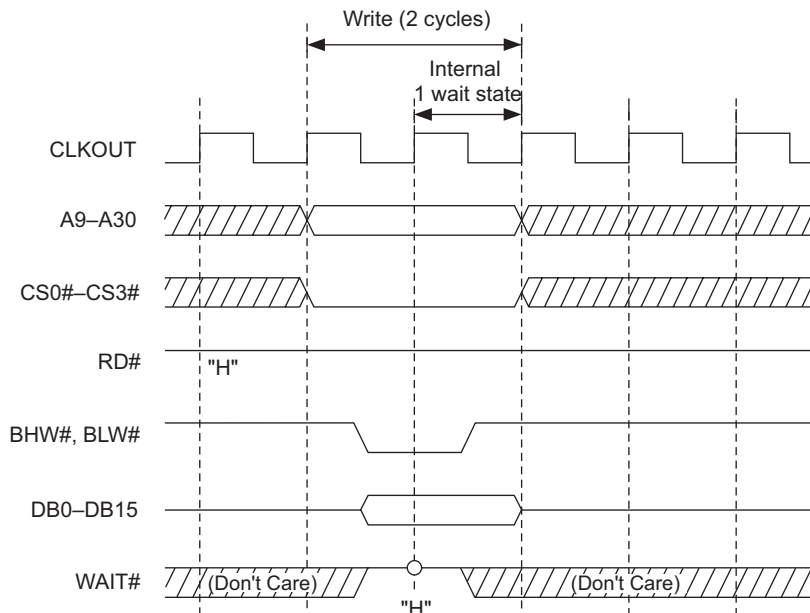
Bus Mode Control Register (Note 1)  
 BUSMOD bit = 0 (WR signal separated)

CS Area Wait Control Register (Note 2)  
 WAIT bit = 0001 (1 wait)  
 CWAIT bit = 0 (without CS wait)  
 SWAIT bit = 0 (without strobe wait)  
 RECOV bit = 0 (without recovery cycle)  
 IDLE bit = 1 (with idle cycle)

Read



Write



Note 1: For details about the Bus Mode Control Register, see Section 17.2.2, "Bus Mode Control Register."

Note 2: For details about the CS Area Wait Control Register, see Section 18.2.1, "CS Area Wait Control Registers."

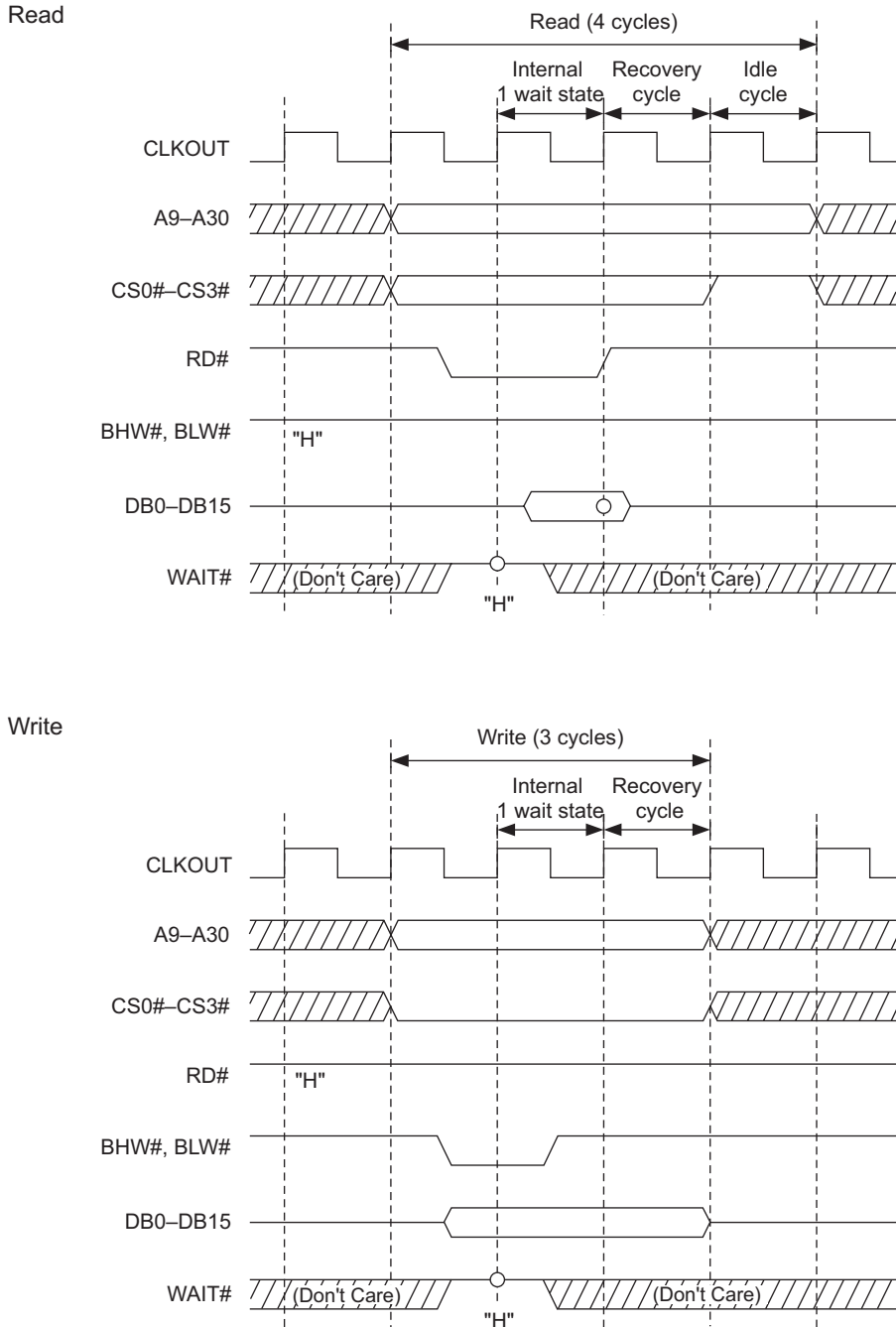
Notes: • Circles in the above diagram indicate the sampling timing.

• No idle cycles are added after the write cycle.

**Figure 18.3.11 Read/Write Timing (Internal 1 Wait State + Idle Cycle Added)**

Bus Mode Control Register (Note 1)  
 BUSMOD bit = 0 (WR signal separated)

CS Area Wait Control Register (Note 2)  
 WAIT bit = 0001 (1 wait)  
 CWAIT bit = 0 (without CS wait)  
 SWAIT bit = 0 (without strobe wait)  
 RECOV bit = 1 (with recovery cycle)  
 IDLE bit = 1 (with idle cycle)



Note 1: For details about the Bus Mode Control Register, see Section 17.2.2, "Bus Mode Control Register."

Note 2: For details about the CS Area Wait Control Register, see Section 18.2.1, "CS Area Wait Control Registers."

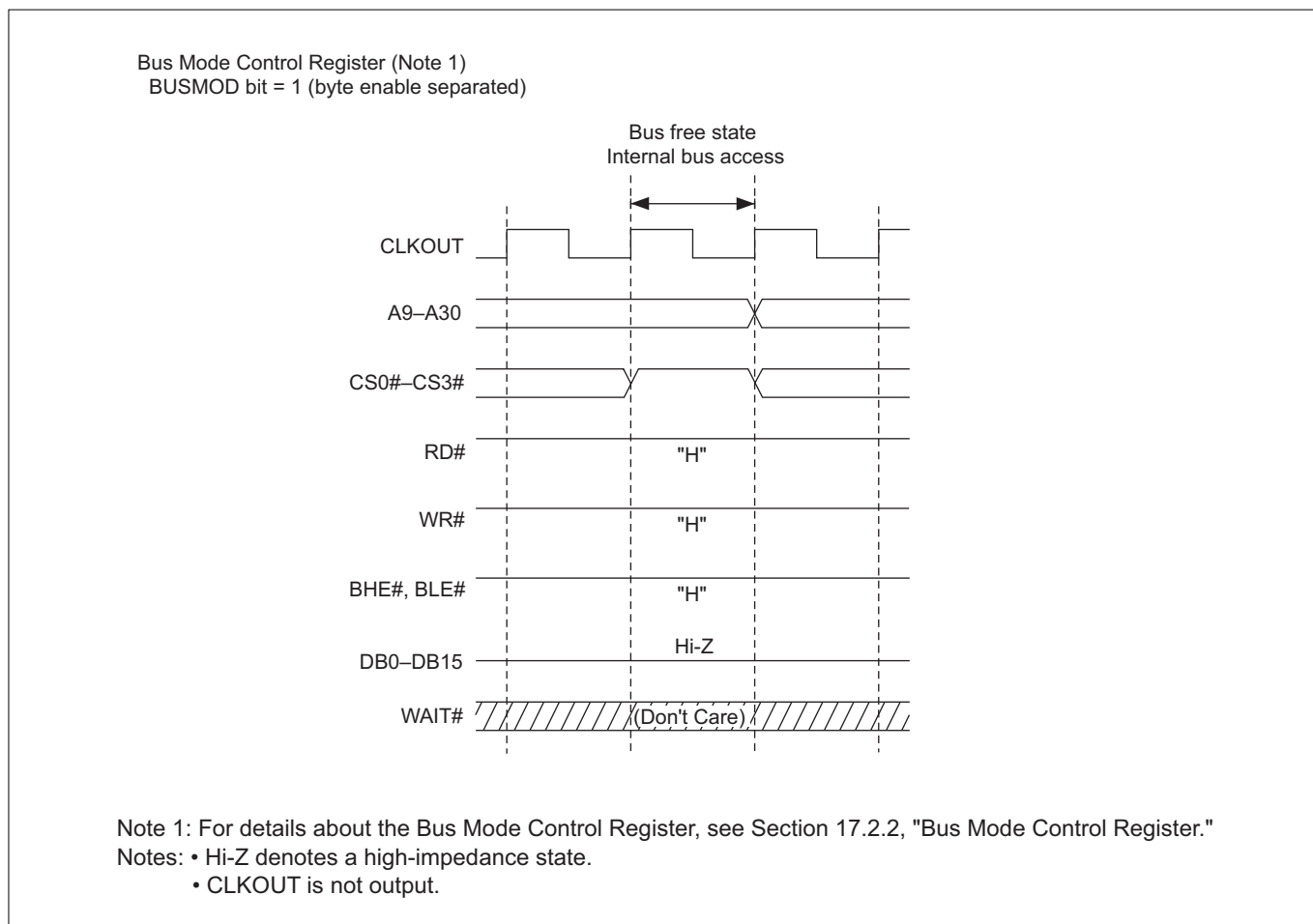
Notes: • Circles in the above diagram indicate the sampling timing.

• No idle cycles are added after the write cycle.

**Figure 18.3.12 Read/Write Timing (Internal 1 Wait State + Recovery and Idle Cycles Added)**

#### (2) When the Bus Mode Control Register = 1

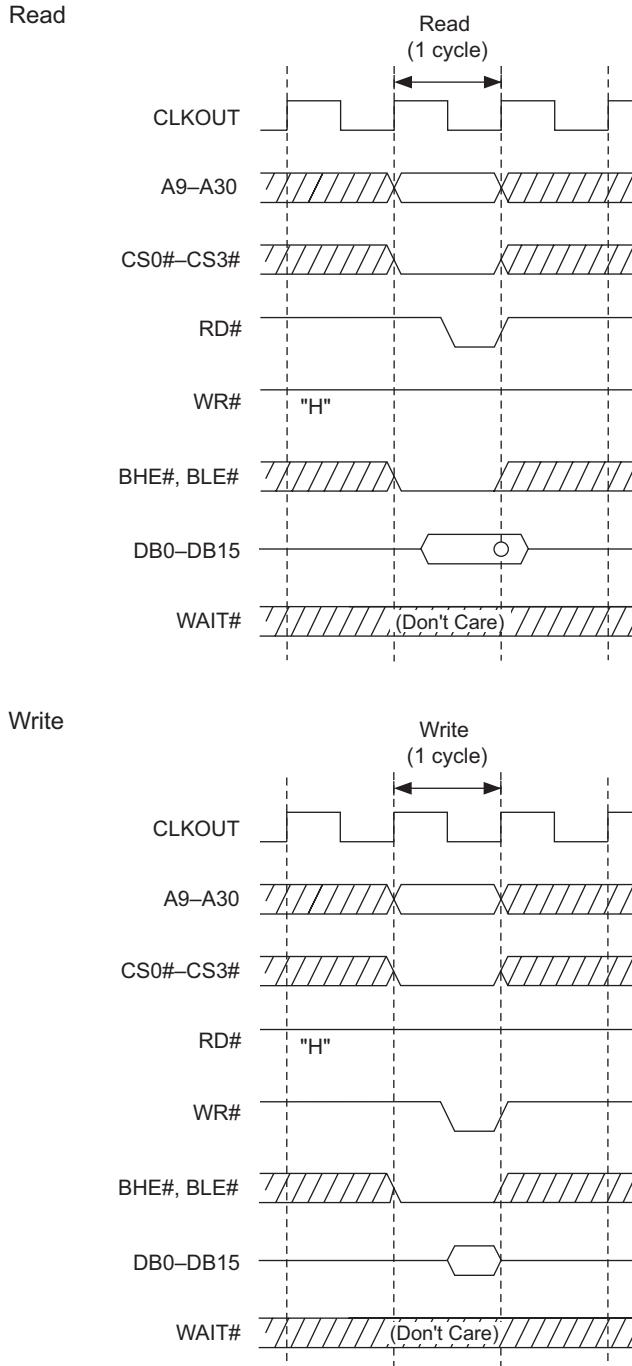
External read/write operations are performed using the address bus, data bus and the signals CS0#–CS3#, RD#, BHE#, BLE#, WAIT#, WR# and BCLK.



**Figure 18.3.13 Internal Bus Access during Bus Free State**

Bus Mode Control Register (Note 1)  
 BUSMOD bit = 1 (byte enable separated)

CS Area Wait Control Register (Note 2)  
 WAIT bit = 0000 (zero wait)  
 CWAIT bit = 0 (without CS wait)  
 SWAIT bit = 0 (without strobe wait)  
 RECOV bit = 0 (without recovery cycle)  
 IDLE bit = 0 (without idle cycle)



Note 1: For details about the Bus Mode Control Register, see Section 17.2.2, "Bus Mode Control Register."

Note 2: For details about the CS Area Wait Control Register, see Section 18.2.1, "CS Area Wait Control Registers."

Notes: • Circles in the above diagram indicate the sampling timing.

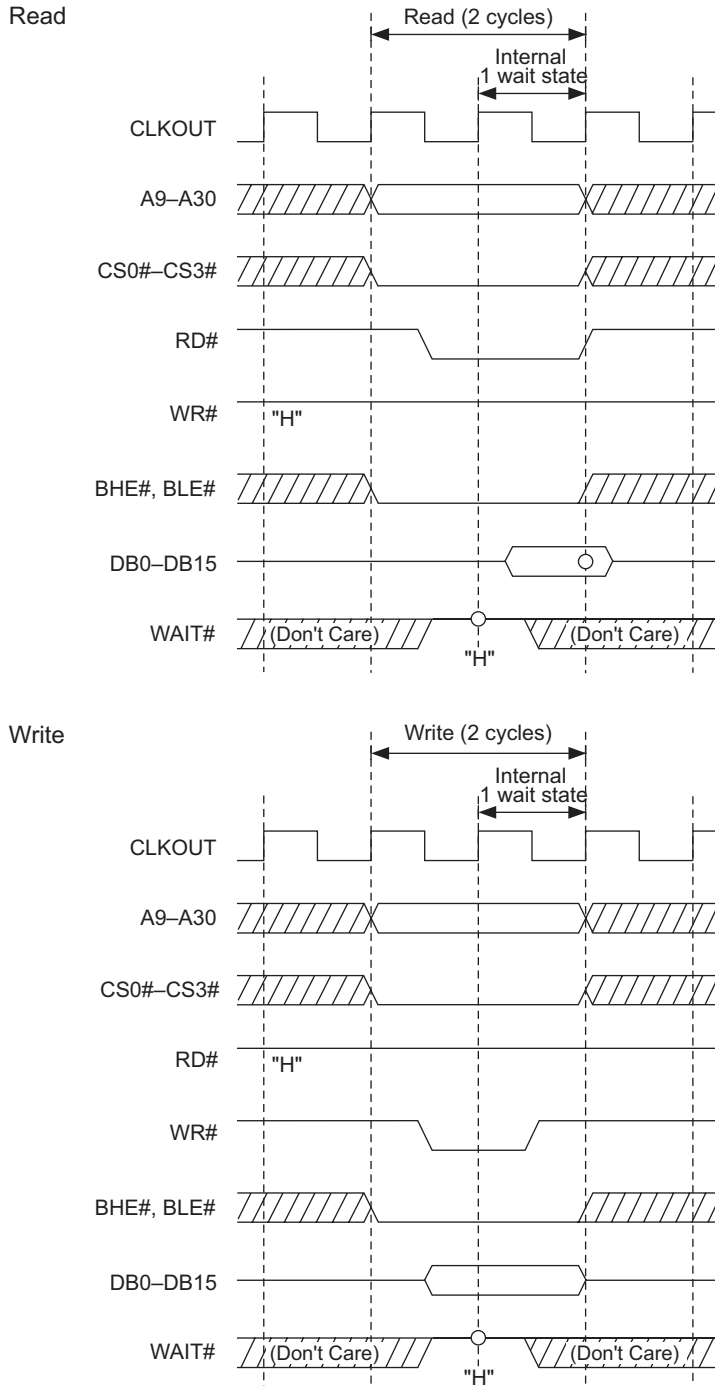
- When zero wait state is selected, wait states inserted by WAIT# are not accepted.
- CLKOUT is not output.

**Figure 18.3.14 Read/Write Timing (for Zero Wait Access)**



Bus Mode Control Register (Note 1)  
 BUSMOD bit = 1 (byte enable separated)

CS Area Wait Control Register (Note 2)  
 WAIT bit = 0001 (1 wait)  
 CWAIT bit = 0 (without CS wait)  
 SWAIT bit = 0 (without strobe wait)  
 RECOV bit = 0 (without recovery cycle)  
 IDLE bit = 0 (without idle cycle)



Note 1: For details about the Bus Mode Control Register, see Section 17.2.2, "Bus Mode Control Register."

Note 2: For details about the CS Area Wait Control Register, see Section 18.2.1, "CS Area Wait Control Registers."

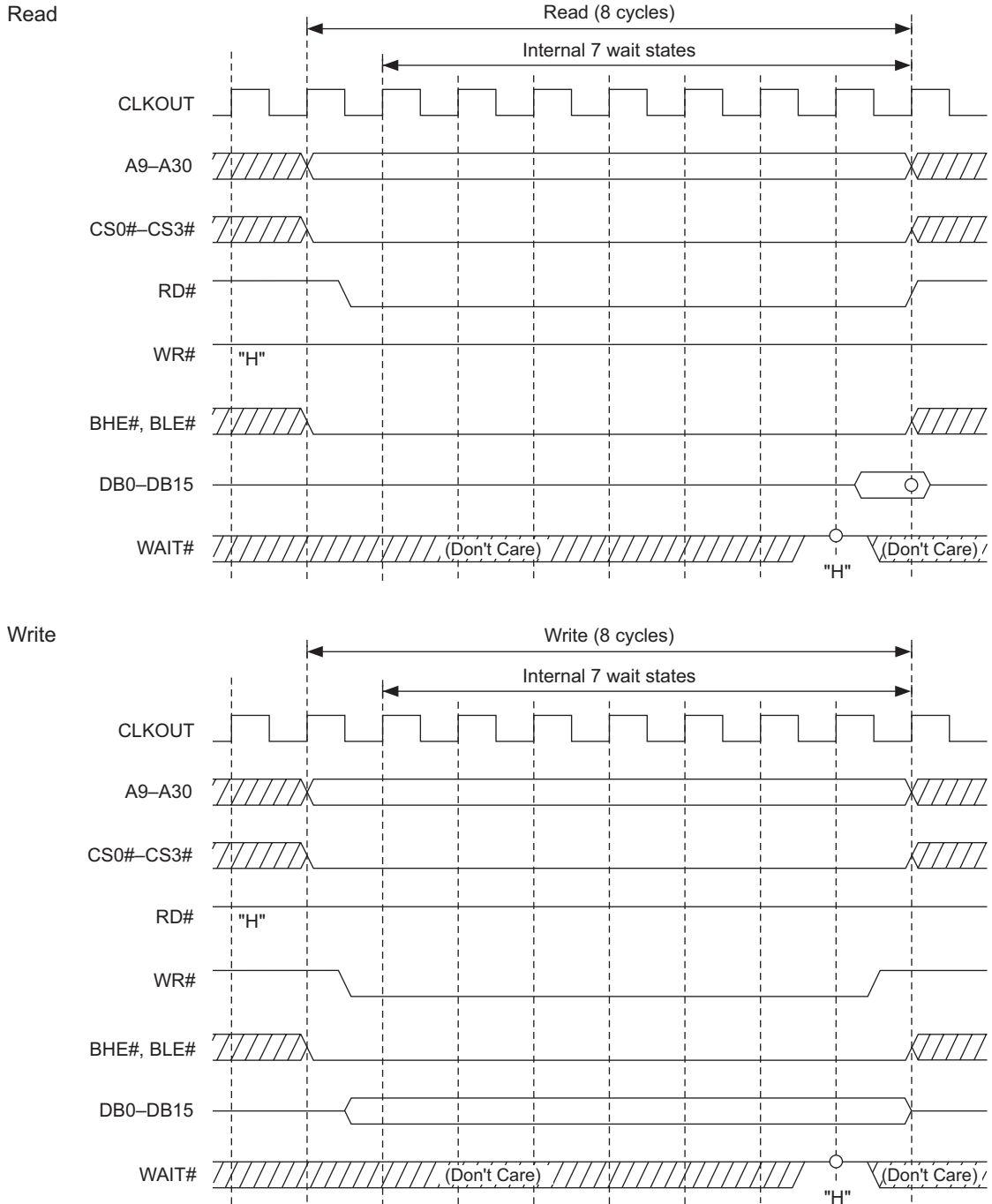
Notes: • Circles in the above diagram indicate the sampling timing.

• CLKOUT is not output.

**Figure 18.3.15 Read/Write Timing (for Access with Internal 1 Wait State)**

Bus Mode Control Register (Note 1)  
 BUSMOD bit = 1 (byte enable separated)

CS Area Wait Control Register (Note 2)  
 WAIT bit = 0111 (7 wait)  
 CWAIT bit = 0 (without CS wait)  
 SWAIT bit = 0 (without strobe wait)  
 RECOV bit = 0 (without recovery cycle)  
 IDLE bit = 0 (without idle cycle)



Note 1: For details about the Bus Mode Control Register, see Section 17.2.2, "Bus Mode Control Register."

Note 2: For details about the CS Area Wait Control Register, see Section 18.2.1, "CS Area Wait Control Registers."

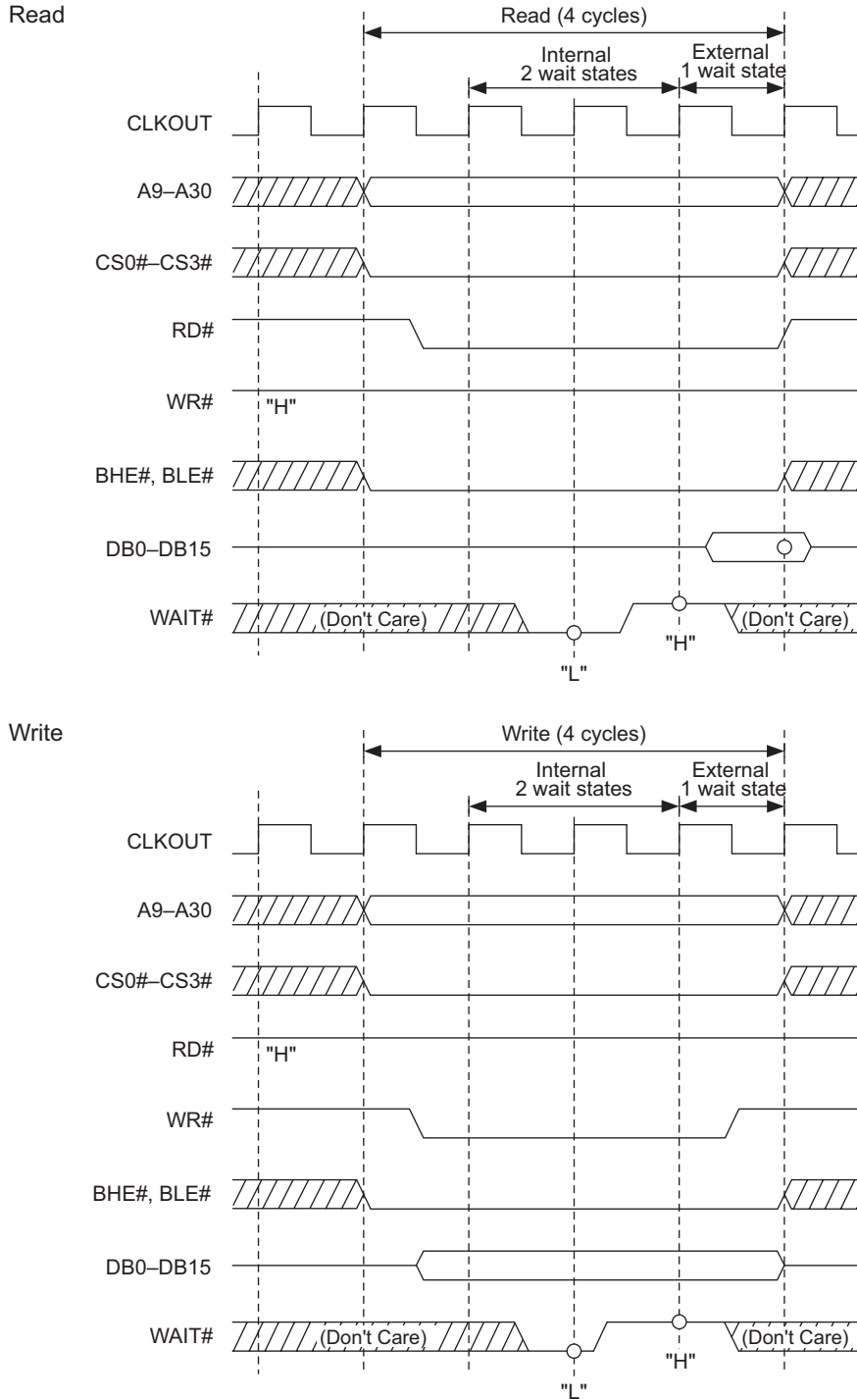
Notes: • Circles in the above diagram indicate the sampling timing.

• CLKOUT is not output.

**Figure 18.3.16 Read/Write Timing (for Access with Internal 7 Wait States)**

Bus Mode Control Register (Note 1)  
 BUSMOD bit = 1 (byte enable separated)

CS Area Wait Control Register (Note 2)  
 WAIT bit = 0010 (2 wait)  
 CWAIT bit = 0 (without CS wait)  
 SWAIT bit = 0 (without strobe wait)  
 RECOV bit = 0 (without recovery cycle)  
 IDLE bit = 0 (without idle cycle)



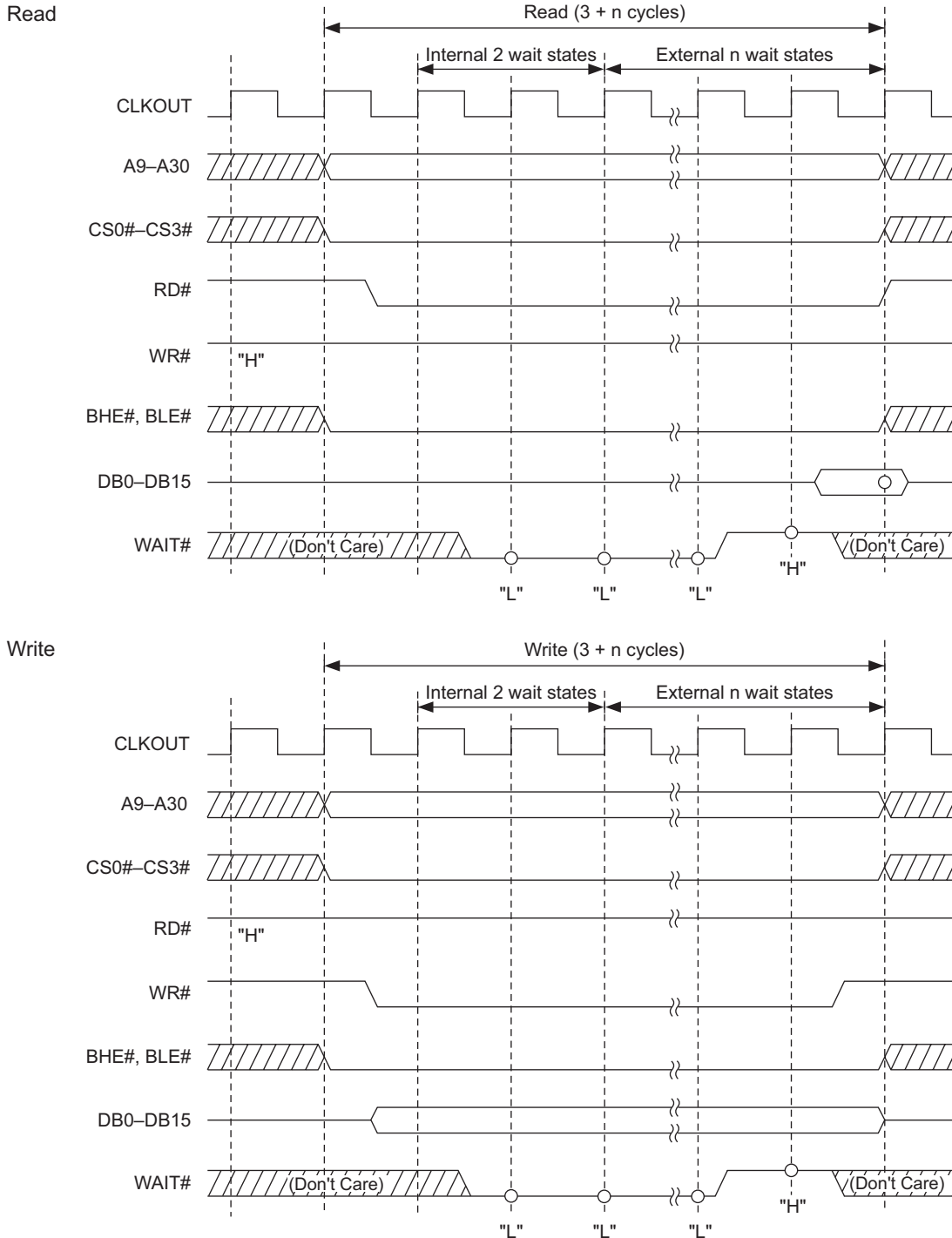
Note 1: For details about the Bus Mode Control Register, see Section 17.2.2, "Bus Mode Control Register."  
 Note 2: For details about the CS Area Wait Control Register, see Section 18.2.1, "CS Area Wait Control Registers."

Notes: • Circles in the above diagram indicate the sampling timing.  
 • CLKOUT is not output.

**Figure 18.3.17 Read/Write Timing (for Access with Internal 2 and External 1 Wait States)**

Bus Mode Control Register (Note 1)  
 BUSMOD bit = 1 (byte enable separated)

CS Area Wait Control Register (Note 2)  
 WAIT bit = 0010 (2 wait)  
 CWAIT bit = 0 (without CS wait)  
 SWAIT bit = 0 (without strobe wait)  
 RECOV bit = 0 (without recovery cycle)  
 IDLE bit = 0 (without idle cycle)



Note 1: For details about the Bus Mode Control Register, see Section 17.2.2, "Bus Mode Control Register."

Note 2: For details about the CS Area Wait Control Register, see Section 18.2.1, "CS Area Wait Control Registers."

Notes: • Circles in the above diagram indicate the sampling timing.

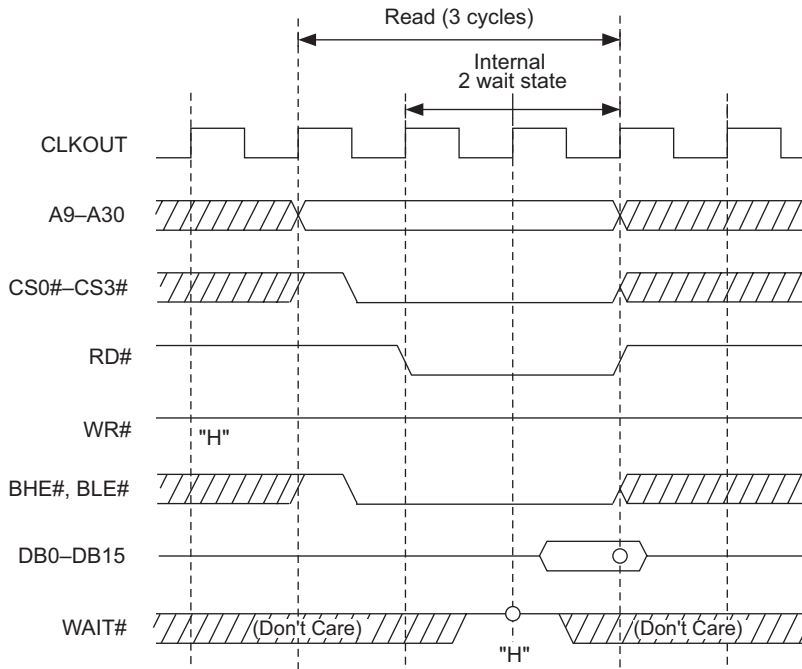
• CLKOUT is not output.

**Figure 18.3.18 Read/Write Timing (for Access with Internal 2 and External n Wait States)**

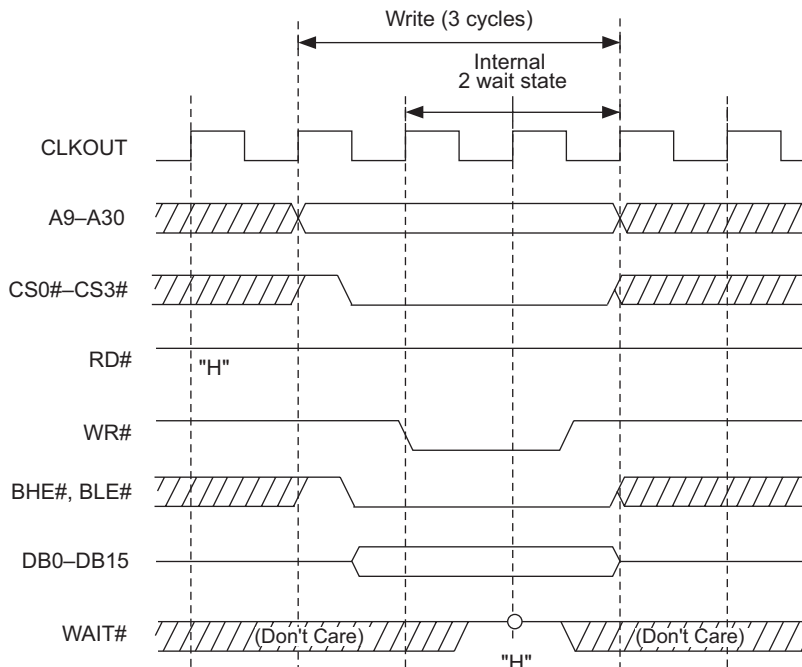
Bus Mode Control Register (Note 1)  
 BUSMOD bit = 1 (byte enable separated)

CS Area Wait Control Register (Note 2)  
 WAIT bit = 0010 (2 wait)  
 CWAIT bit = 1 (with CS wait)  
 SWAIT bit = 0 (without strobe wait)  
 RECOV bit = 0 (without recovery cycle)  
 IDLE bit = 0 (without idle cycle)

Read



Write



Note 1: For details about the Bus Mode Control Register, see Section 17.2.2, "Bus Mode Control Register."

Note 2: For details about the CS Area Wait Control Register, see Section 18.2.1, "CS Area Wait Control Registers."

Notes: • Circles in the above diagram indicate the sampling timing.

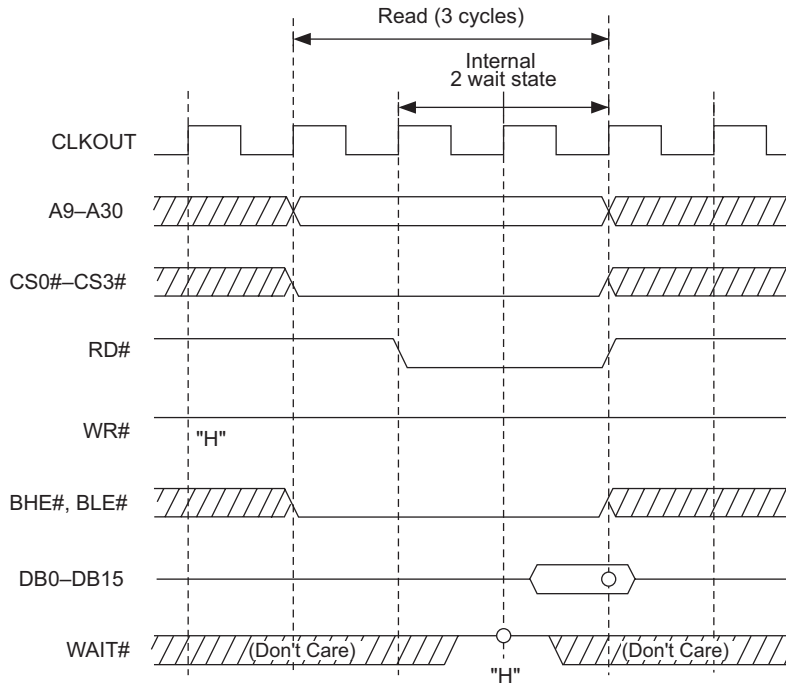
• CLKOUT is not output.

**Figure 18.3.19 Read/Write Timing (for Access with Internal 2 Wait State + CS Wait)**

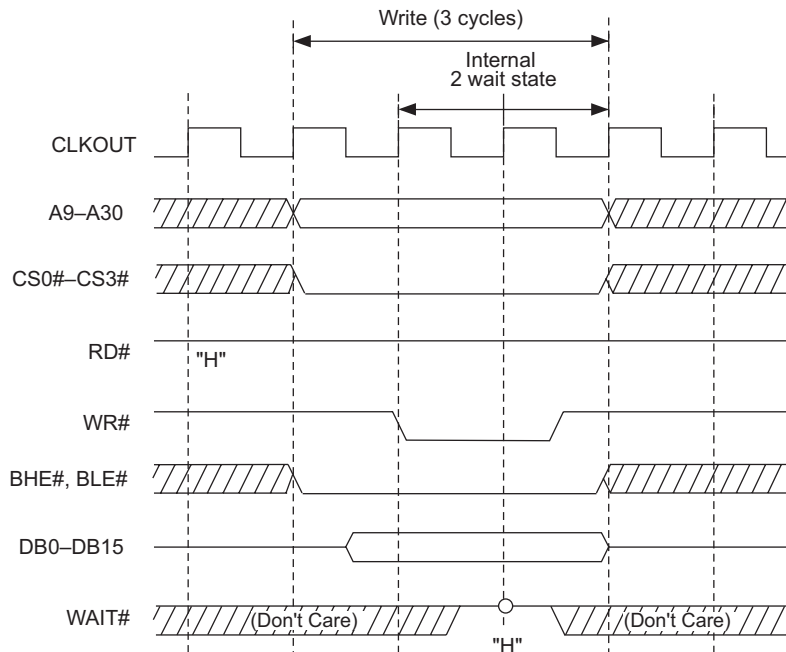
Bus Mode Control Register (Note 1)  
 BUSMOD bit = 1 (byte enable separated)

CS Area Wait Control Register (Note 2)  
 WAIT bit = 0010 (2 wait)  
 CWAIT bit = 0 (without CS wait)  
 SWAIT bit = 1 (with strobe wait)  
 RECOV bit = 0 (without recovery cycle)  
 IDLE bit = 0 (without idle cycle)

Read



Write



Note 1: For details about the Bus Mode Control Register, see Section 17.2.2, "Bus Mode Control Register."

Note 2: For details about the CS Area Wait Control Register, see Section 18.2.1, "CS Area Wait Control Registers."

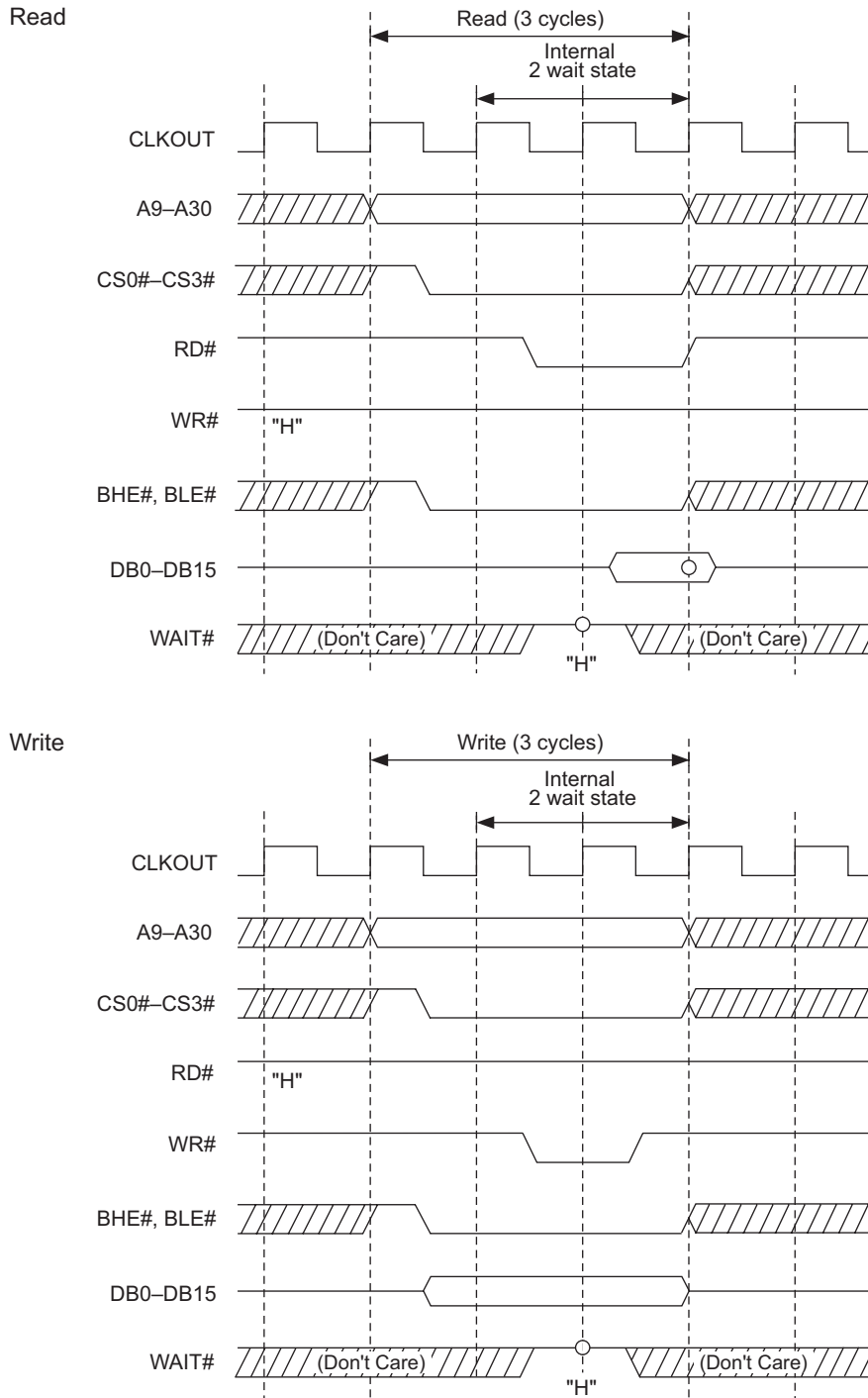
Notes: • Circles in the above diagram indicate the sampling timing.

• CLKOUT is not output.

**Figure 18.3.20 Read/Write Timing (for Access with Internal 2 Wait State + Strobe Wait)**

Bus Mode Control Register (Note 1)  
 BUSMOD bit = 1 (byte enable separated)

CS Area Wait Control Register (Note 2)  
 WAIT bit = 0010 (2 wait)  
 CWAIT bit = 1 (with CS wait)  
 SWAIT bit = 1 (with strobe wait)  
 RECOV bit = 0 (without recovery cycle)  
 IDLE bit = 0 (without idle cycle)



Note 1: For details about the Bus Mode Control Register, see Section 17.2.2, "Bus Mode Control Register."

Note 2: For details about the CS Area Wait Control Register, see Section 18.2.1, "CS Area Wait Control Registers."

Notes: • Circles in the above diagram indicate the sampling timing.

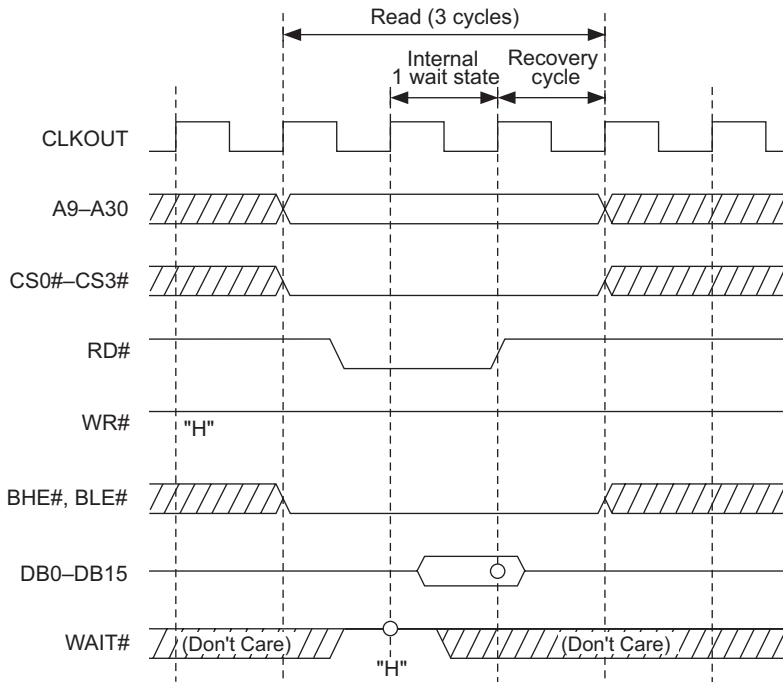
• CLKOUT is not output.

**Figure 18.3.21 Read/Write Timing (for Access with Internal 2 Wait States + CS/Strobe Wait)**

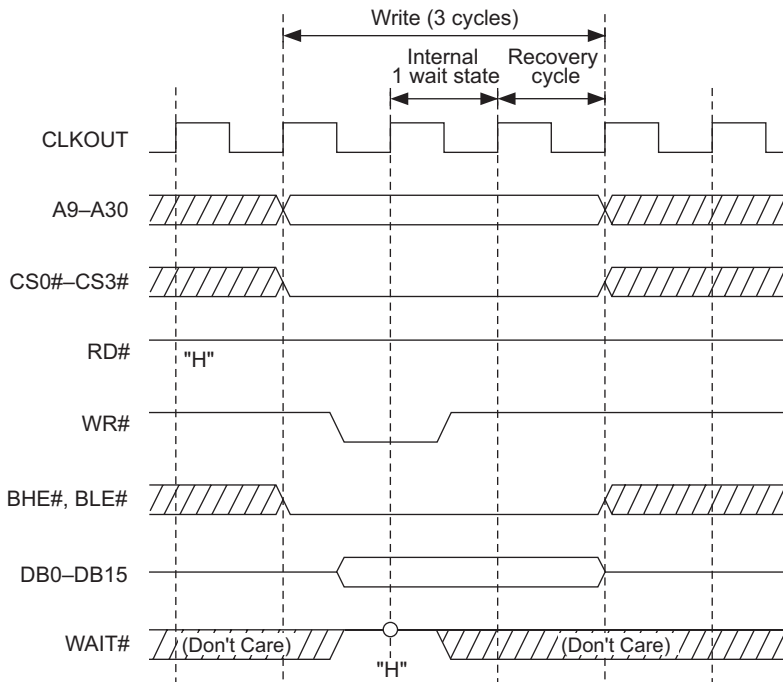
Bus Mode Control Register (Note 1)  
 BUSMOD bit = 1 (byte enable separated)

CS Area Wait Control Register (Note 2)  
 WAIT bit = 0001 (1 wait)  
 CWAIT bit = 0 (without CS wait)  
 SWAIT bit = 0 (without strobe wait)  
 RECOV bit = 1 (with recovery cycle)  
 IDLE bit = 0 (without idle cycle)

Read



Write



Note 1: For details about the Bus Mode Control Register, see Section 17.2.2, "Bus Mode Control Register."

Note 2: For details about the CS Area Wait Control Register, see Section 18.2.1, "CS Area Wait Control Registers."

Notes: • Circles in the above diagram indicate the sampling timing.

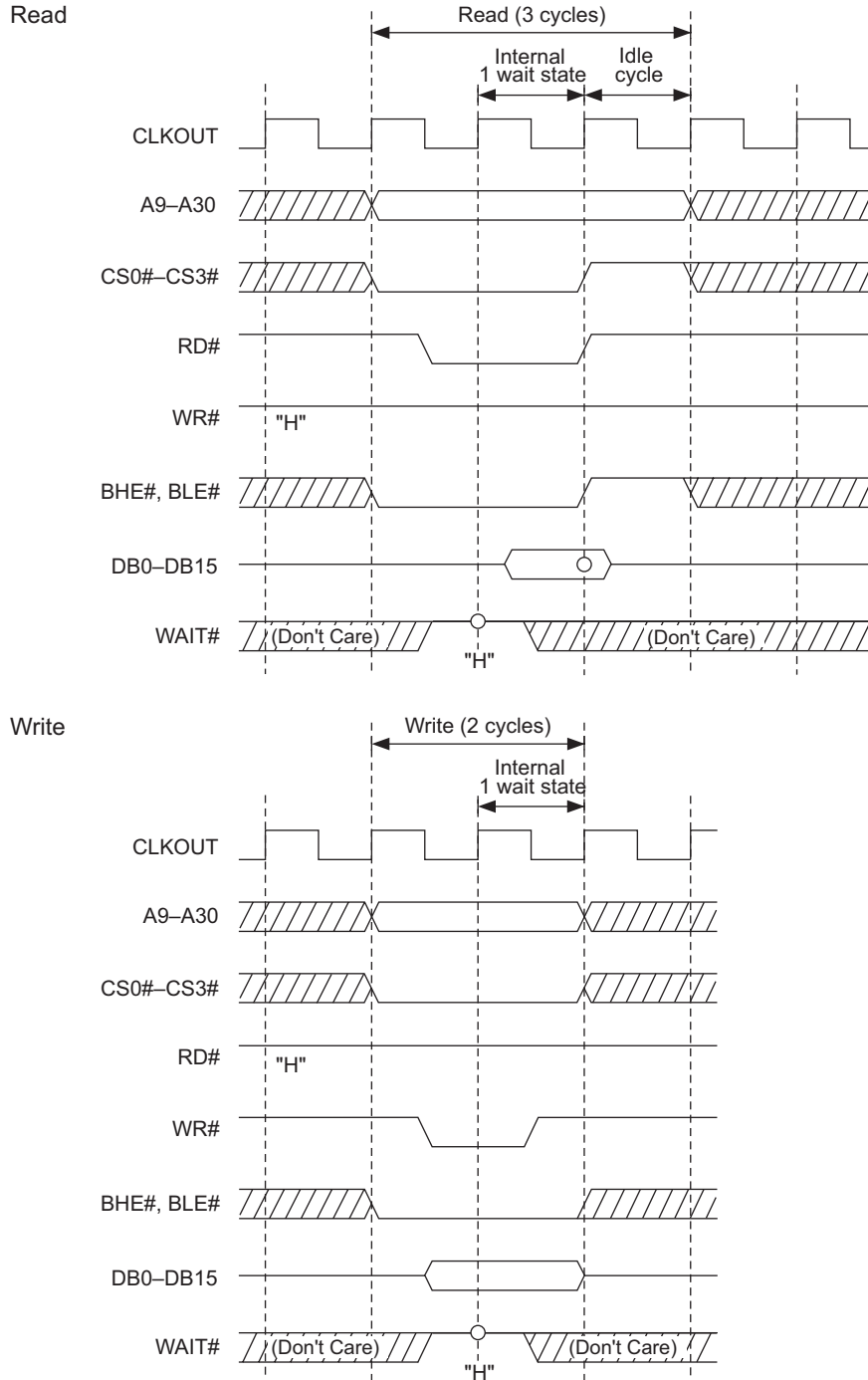
• CLKOUT is not output.

**Figure 18.3.22 Read/Write Timing (Internal 1 Wait State + Recovery Cycle Added)**



Bus Mode Control Register (Note 1)  
 BUSMOD bit = 1 (byte enable separated)

CS Area Wait Control Register (Note 2)  
 WAIT bit = 0001 (1 wait)  
 CWAIT bit = 0 (without CS wait)  
 SWAIT bit = 0 (without strobe wait)  
 RECOV bit = 0 (without recovery cycle)  
 IDLE bit = 1 (with idle cycle)



Note 1: For details about the Bus Mode Control Register, see Section 17.2.2, "Bus Mode Control Register."

Note 2: For details about the CS Area Wait Control Register, see Section 18.2.1, "CS Area Wait Control Registers."

Notes: • Circles in the above diagram indicate the sampling timing.

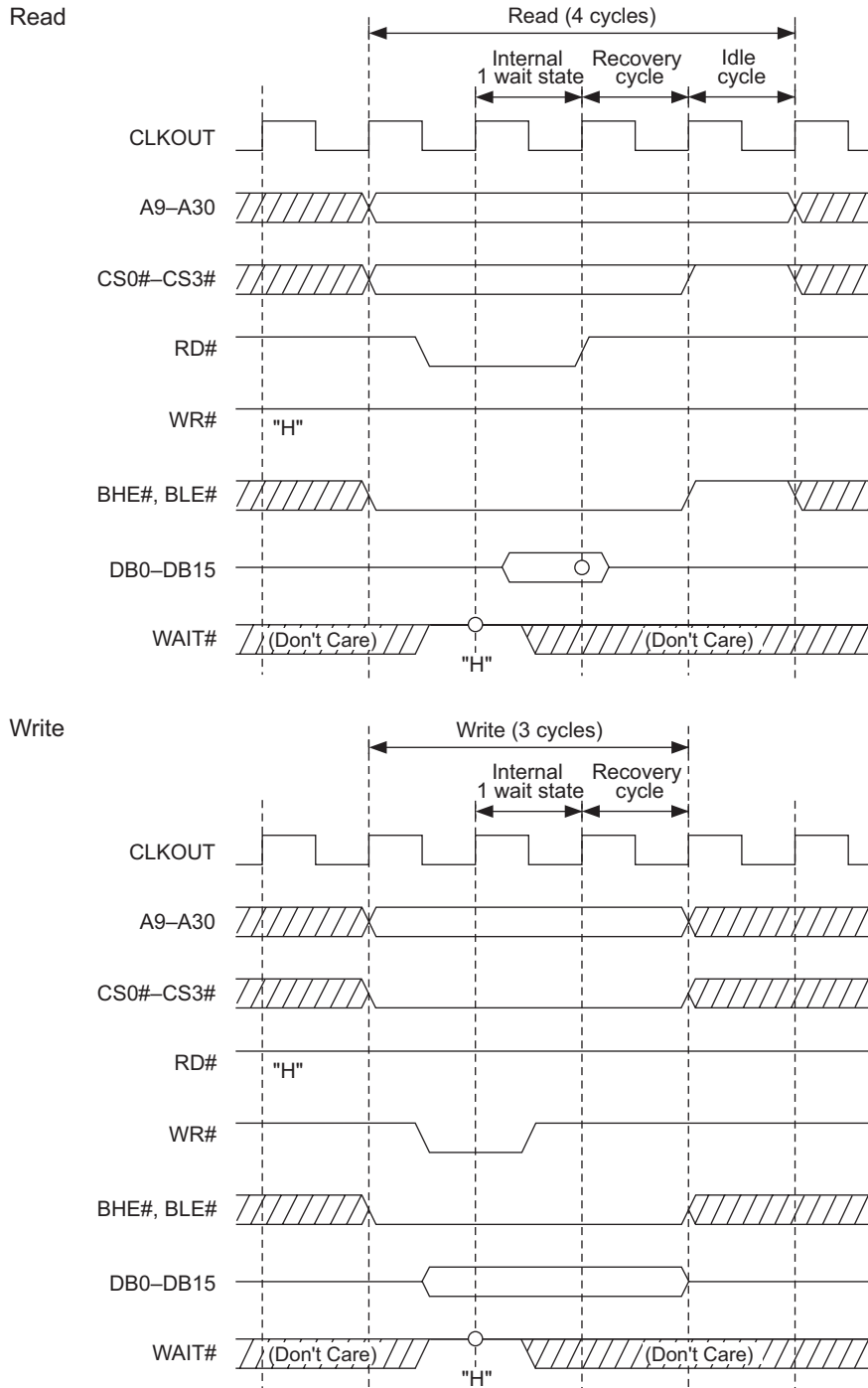
• CLKOUT is not output.

• No idle cycles are added after the write cycle.

**Figure 18.3.23 Read/Write Timing (Internal 1 Wait State + Idle Cycle Added)**

Bus Mode Control Register (Note 1)  
 BUSMOD bit = 1 (byte enable separated)

CS Area Wait Control Register (Note 2)  
 WAIT bit = 0001 (1 wait)  
 CWAIT bit = 0 (without CS wait)  
 SWAIT bit = 0 (without strobe wait)  
 RECOV bit = 1 (with recovery cycle)  
 IDLE bit = 1 (with idle cycle)



Note 1: For details about the Bus Mode Control Register, see Section 17.2.2, "Bus Mode Control Register."  
 Note 2: For details about the CS Area Wait Control Register, see Section 18.2.1, "CS Area Wait Control Registers."  
 Notes: • Circles in the above diagram indicate the sampling timing.  
 • CLKOUT is not output.  
 • No idle cycles are added after the write cycle.

**Figure 18.3.24 Read/Write Timing (Internal 1 Wait State + Recovery and Idle Cycles Added)**

## CHAPTER 19

---

# RAM BACKUP MODE

- 19.1 Outline of RAM Backup Mode
- 19.2 Example of RAM Backup when Power is Off
- 19.3 Example of RAM Backup for Saving Power Consumption
- 19.4 Exiting RAM Backup Mode (Wakeup)

#### 19.1 Outline of RAM Backup Mode

In RAM backup mode, parts of the internal RAM are retained while the power is turned off. RAM backup mode is used for the following two purposes.

RAM backup area for the 32192 is from H'0080 4000 to H'0081 3FFF (64KB).

RAM backup area for the 32195/32196 is from H'0080 4000 to H'0080 7FFF (16KB).

- Backup parts of the internal RAM data when the power is forcibly turned off from the outside (RAM backup when the power is off)
- For the M32R/ECU to turn off the power to the CPU at any time as needed to reduce the system's power consumption while retaining parts of the internal RAM data . (RAM backup for saving the power consumption)

The M32R/ECU is placed in RAM backup mode by applying a voltage of 3.3 V or 5.0 V to the VDDE pin (provided for RAM backup) and 0 V to all other pins. However, when started by boot mode, internal RAM value is indefinite after started by boot mode in order to "Flash writing/ Erase program" is transferred to internal RAM.

During RAM backup mode, parts of the contents of the internal RAM are retained, while the CPU and internal peripheral I/O remain idle. Because all pins except VDDE are held "L" during RAM backup mode, the power consumption in the system can effectively be reduced.

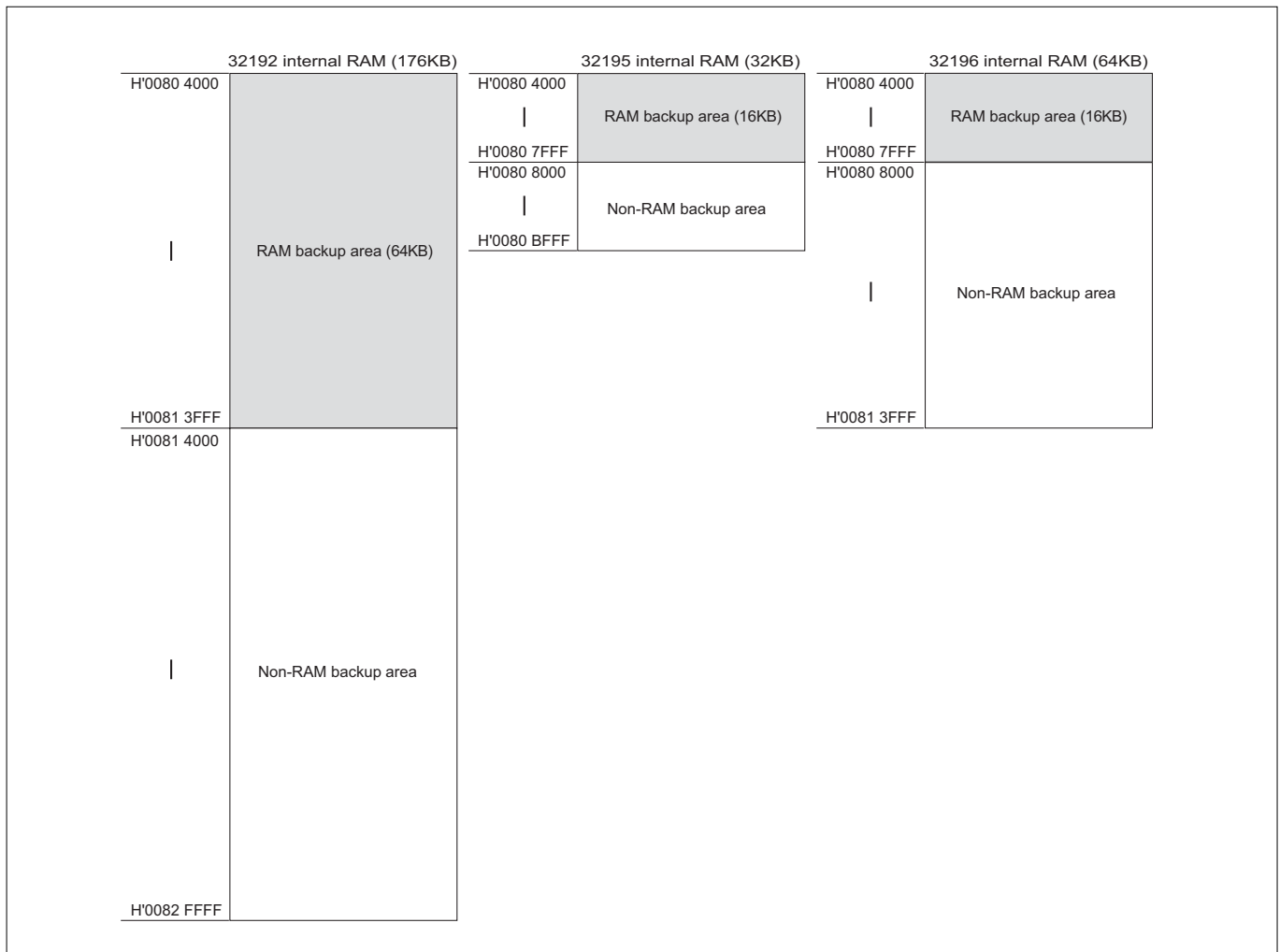


Figure 19.1.1 RAM Backup Area

#### 19.2 Example of RAM Backup when Power is Off

A typical circuit for RAM backup at power outage is shown in Figure 19.2.1. The following explains how the RAM can be backed up by using this circuit as an example.

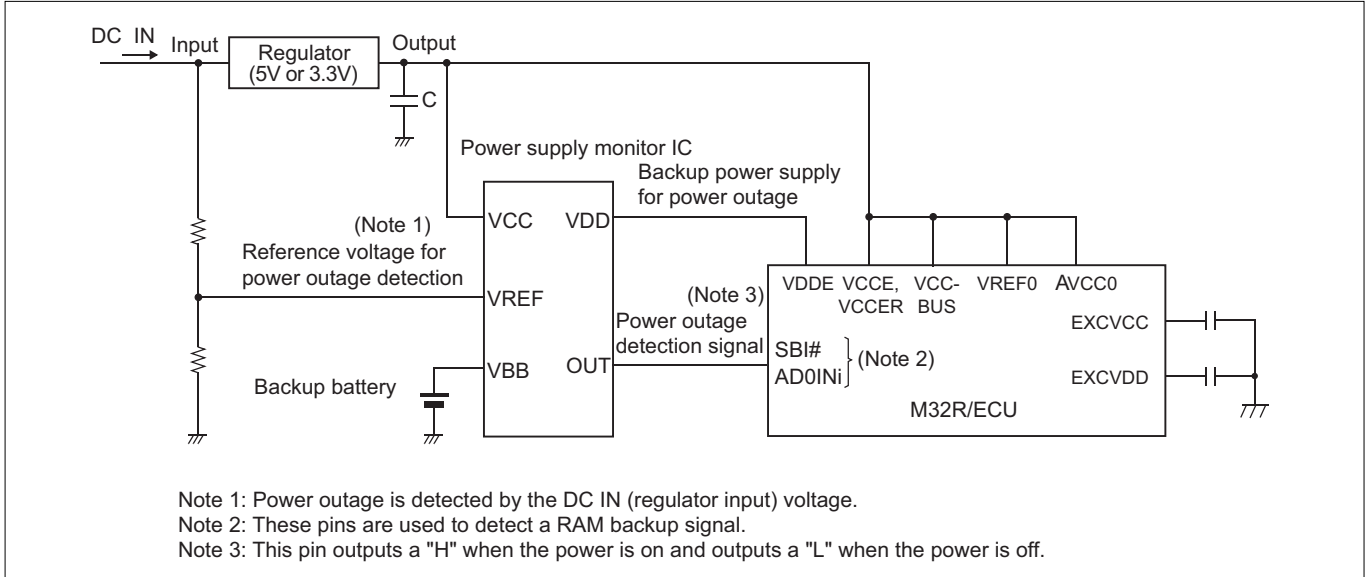


Figure 19.2.1 Typical Circuit for RAM Backup at Power Outage

#### 19.2.1 Normal Operating State

Figure 19.2.2 shows the normal operating state of the M32R/ECU. During normal operation, input on the SBI# pin or AD0INi (i = 0–15) pin which is used to detect a RAM backup signal remains "H."

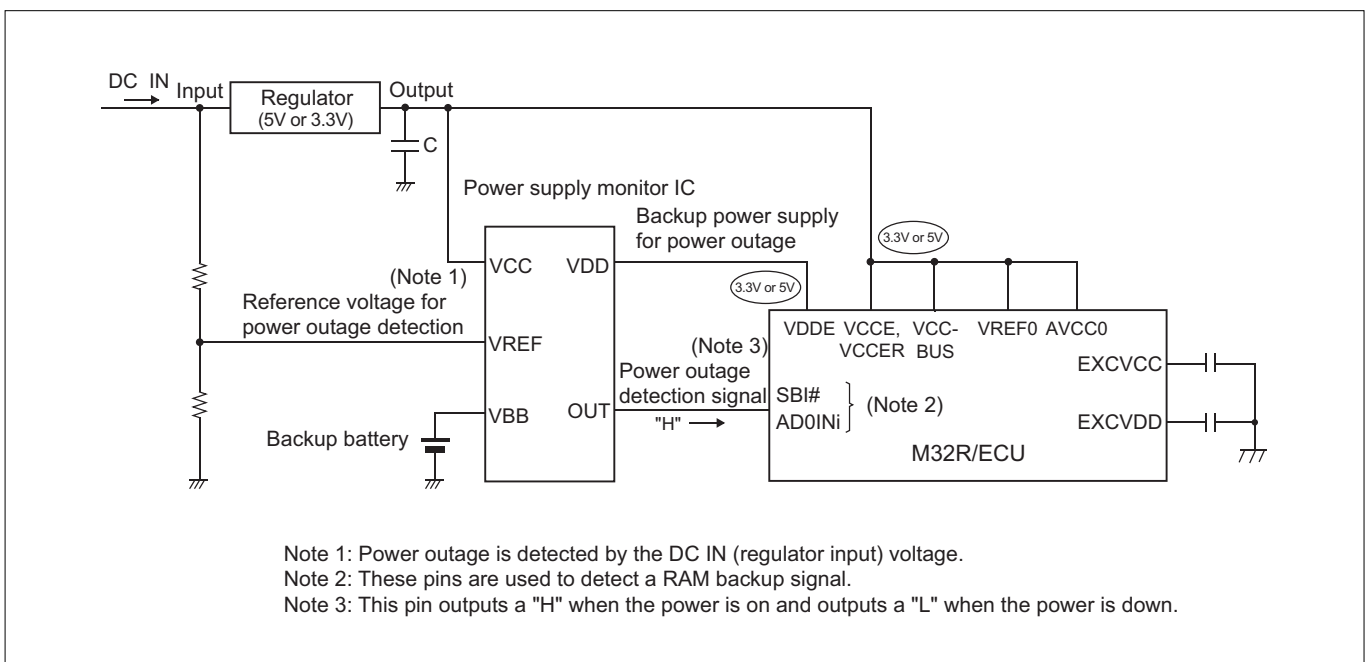


Figure 19.2.2 Normal Operating State

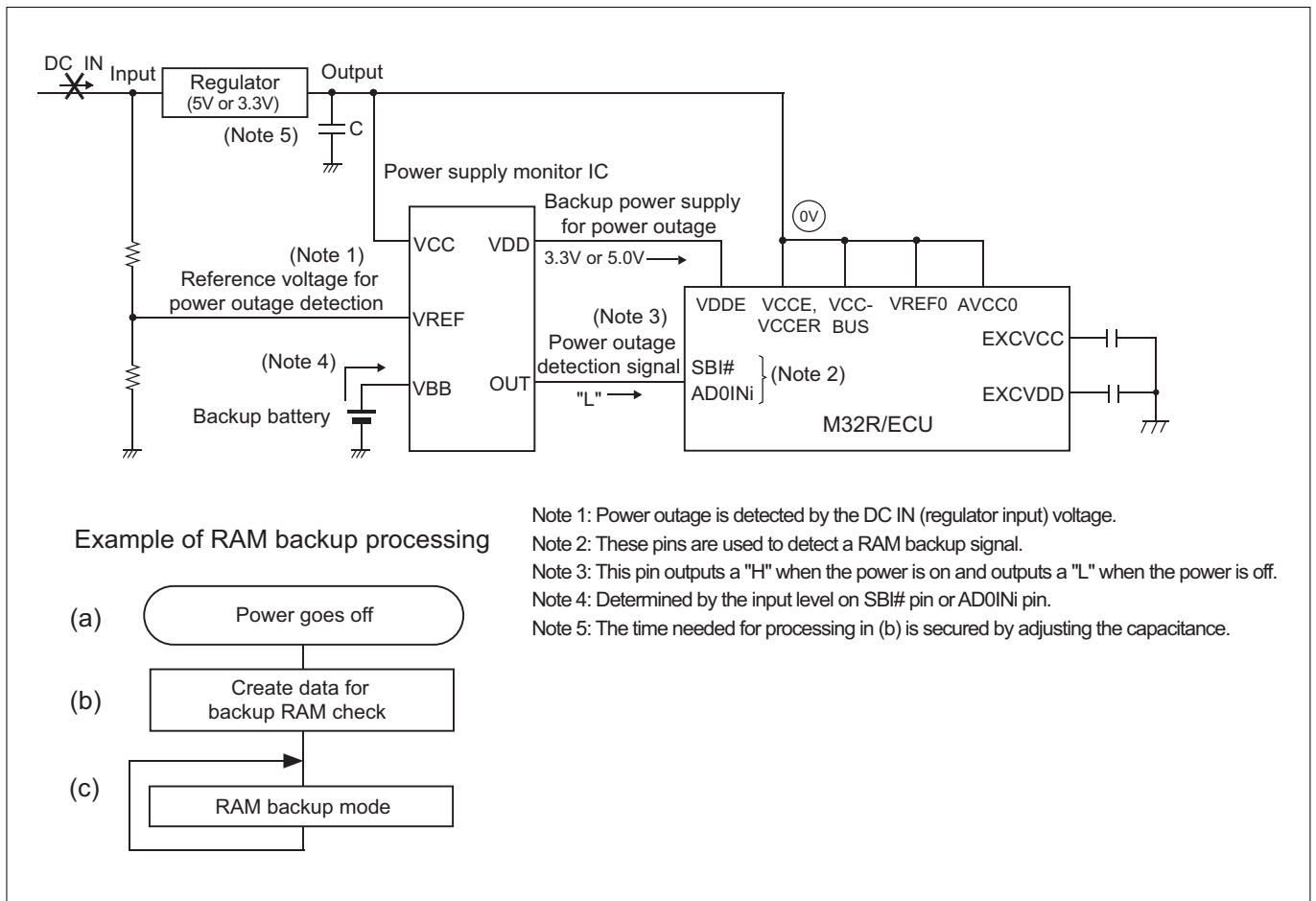
#### 19.2.2 RAM Backup State

Figure 19.2.3 shows the power outage RAM backup state of the M32R/ECU. When the power supply goes off, the power supply monitor IC starts feeding current from the backup battery to the M32R/ECU. Also, the power supply monitor IC's power outage detection pin outputs a "L," causing the SBI# pin or AD0INi pin to go "L," which generates a RAM backup signal ((a) in Figure 19.2.3). Determination of whether the power is off must be made with respect to the DC IN (regulator input) voltage in order to allow for a software processing time at power outage.

To enable RAM backup mode, make the following setting:

- (1) Create data for RAM check to verify whether the RAM data has been retained normally after returning from RAM backup mode to normal mode ((b) in Figure 19.2.3).

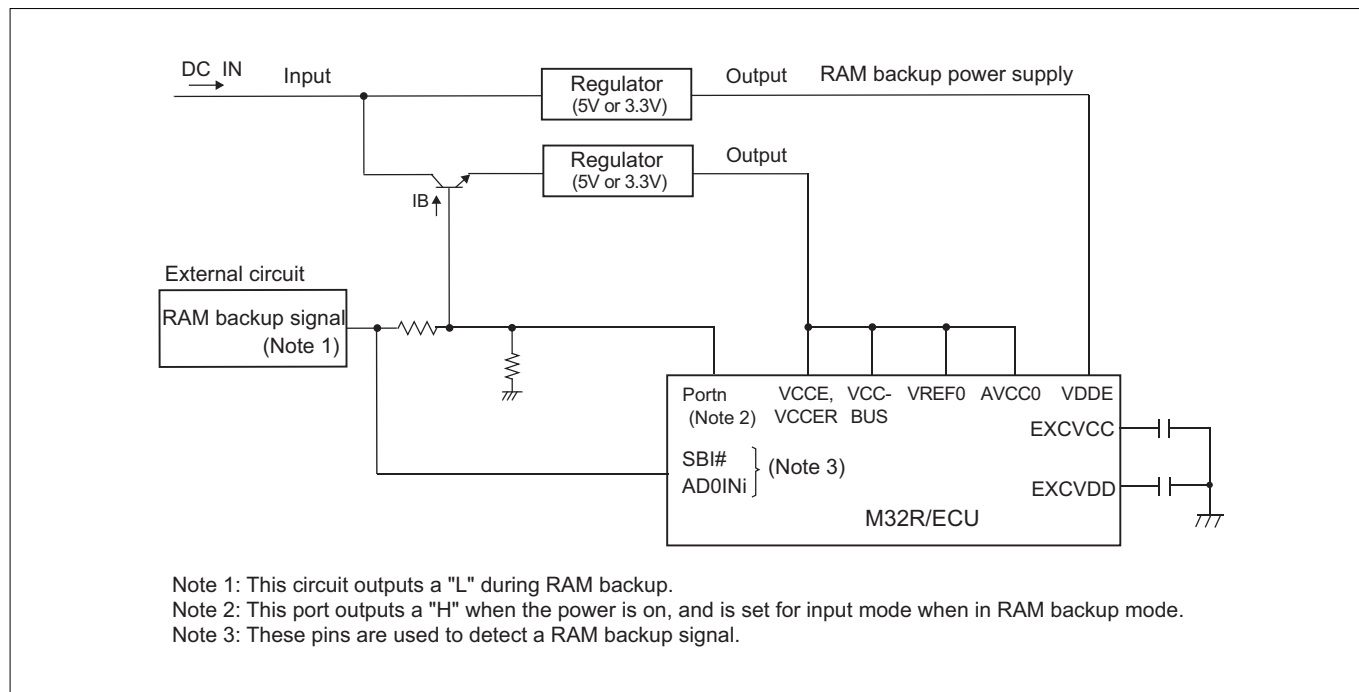
If the power supply to VCCE goes off after making above setting, the VDDE pin voltage goes to 3.0–3.3 V and all other pin voltages drop to 0 V, and the M32R/ECU is thereby placed in RAM backup mode ((c) in Figure 19.2.3).



**Figure 19.2.3 Power Outage RAM Backup State**

### 19.3 Example of RAM Backup for Saving Power Consumption

A typical RAM backup circuit for saving the microcomputer's power consumption is shown in Figure 19.3.1. The following explains how the RAM is backed up for the purpose of low-power operation by using this circuit as an example.

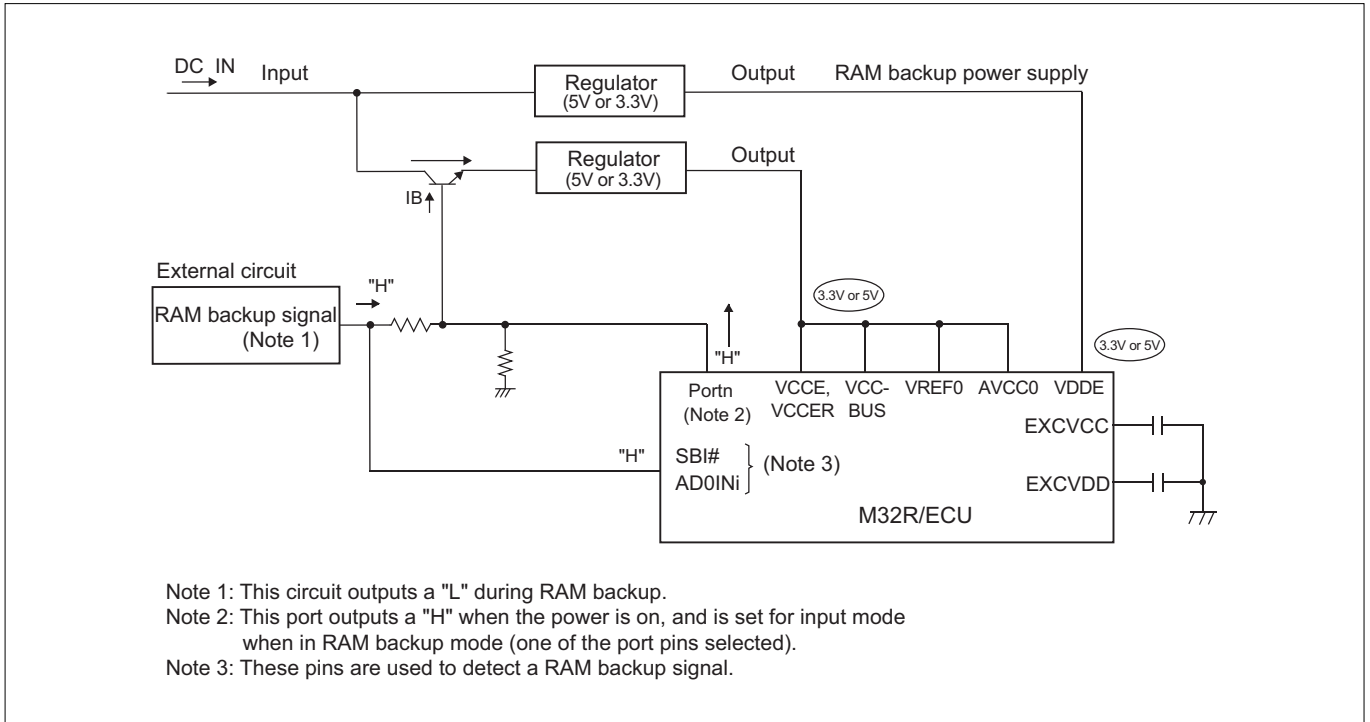


**Figure 19.3.1 Typical RAM Backup Circuit for Saving Power Consumption**

#### 19.3.1 Normal Operating State

Figure 19.3.2 shows the normal operating state of the M32R/ECU. During normal operation, the RAM backup signal output by the external circuit is "H." Also, input on the SBI# pin or AD0INi (i = 0–15) pin which is used to detect a RAM backup signal remains "H."

Portn, which connects to the transistor's base, should output a "H." This causes the transistor's base voltage, IB, to go "H" so that current is fed from the power supply to the VCCE pin via the transistor.



**Figure 19.3.2 Normal Operating State**

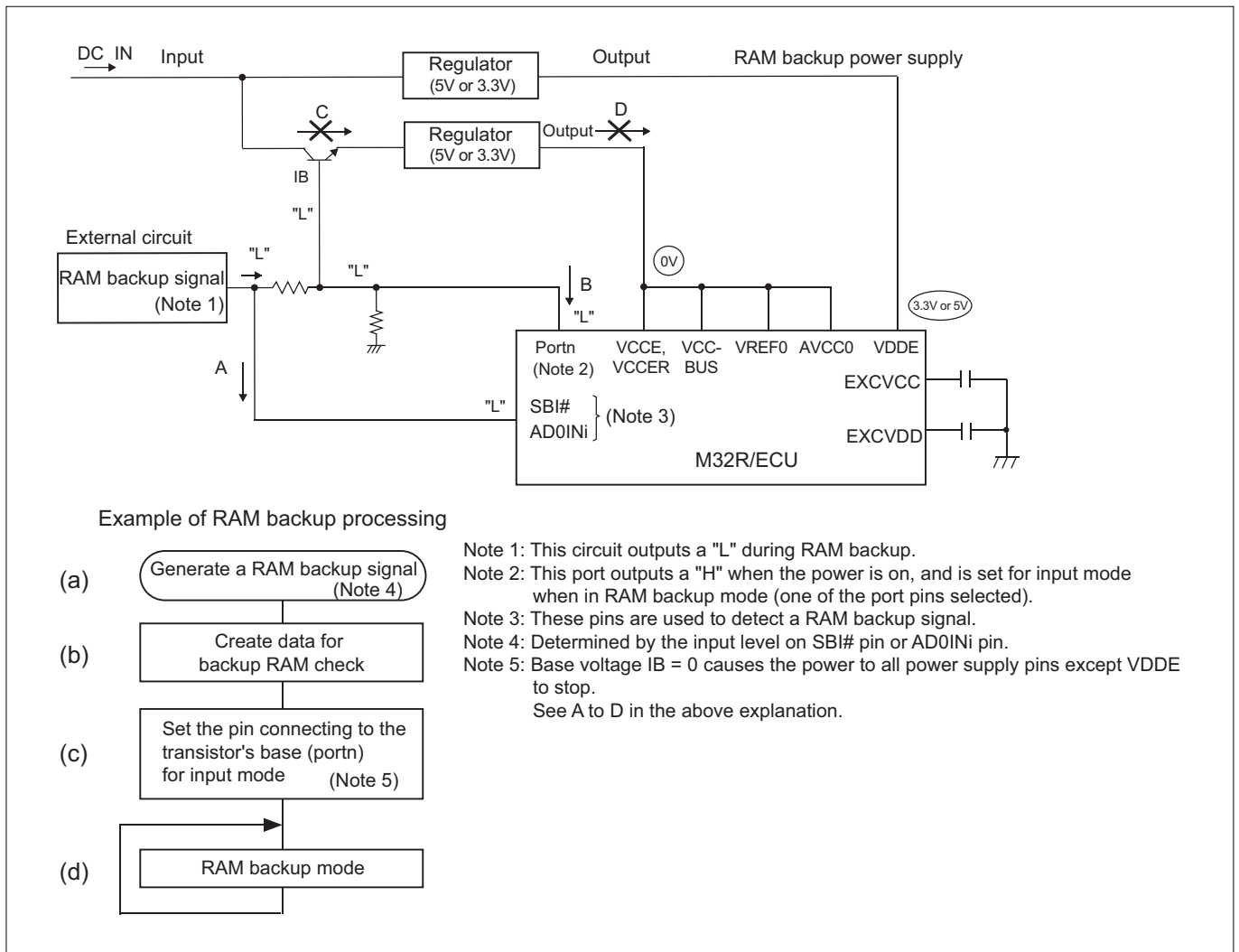


#### 19.3.2 RAM Backup State

Figure 19.3.3 shows the RAM backup state of the M32R/ECU. Figure 19.3.4 shows a RAM backup sequence. When the external circuit outputs a "L," input on the SBI# or AD0INi pin is pulled "L." An "L" on these input pins generates a RAM backup signal (A and (a) in Figure 19.3.3). To enable RAM backup mode, make the following settings:

- (1) Create data for RAM check to verify after returning from RAM backup mode to normal mode whether the RAM data has been retained normally ((b) in Figure 19.3.3).
- (2) To materialize low-power operation, set all programmable input/output pins except portn for input mode (or for output mode, with the output level fixed "L") ((c) in Figure 19.3.3).
- (3) Set portn for input mode (B and (d) in Figure 19.3.3). This causes the transistor's base voltage, IB, to go "L," so that the power to all power supply pins except VDDE is shut off (C and D in Figure 19.3.3).

By settings in (1) to (3), the VDDE pin voltage goes to 3.0–5.5 V and all other pin voltages drop to 0 V, and the M32R/ECU is thereby placed in RAM backup mode ((d) in Figure 19.3.3).



**Figure 19.3.3 RAM Backup State for Low Power Operation**

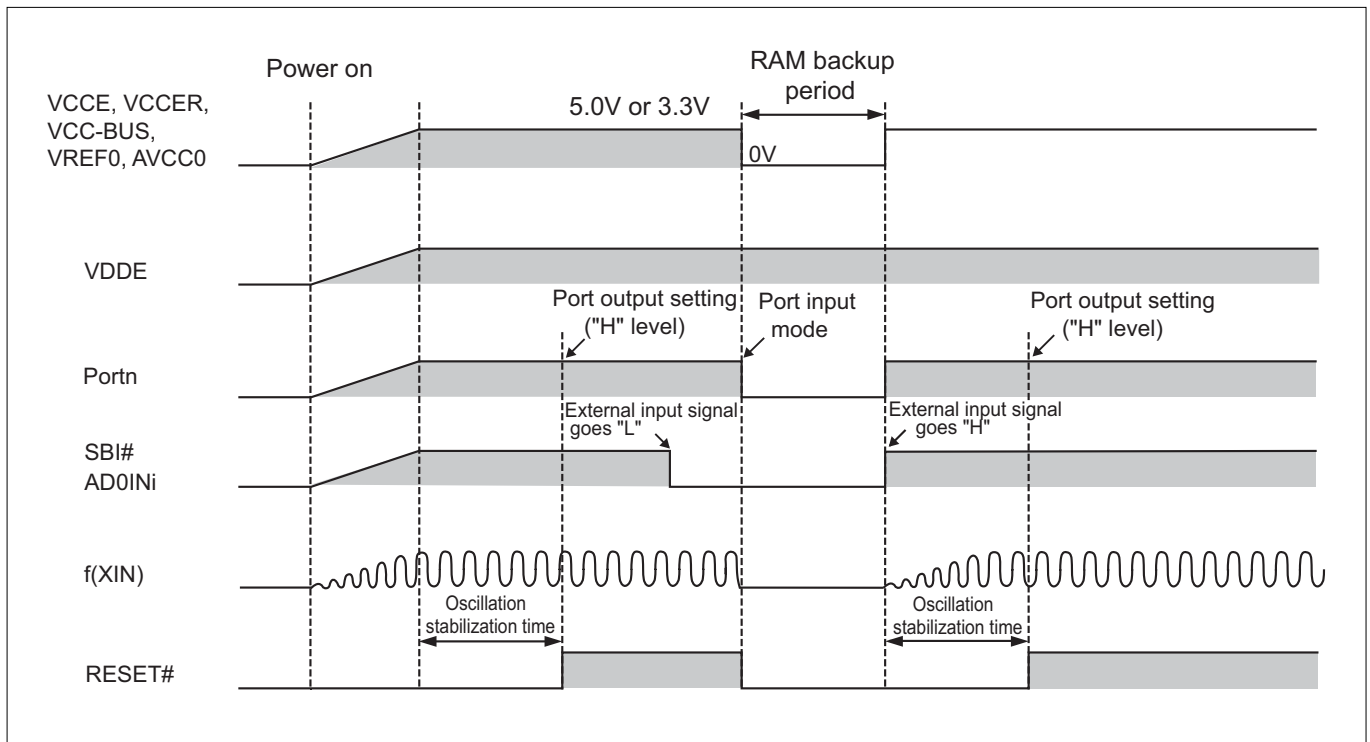


Figure 19.3.4 Example of a RAM Backup Sequence for Low Power Operation

### 19.3.3 Precautions to Be Observed at Power-On

When changing portn from input mode to output mode after power-on, pay attention to the following.

If port n is set for output mode while no data is set in the Portn Data Register, the port's initial output level is instable. Therefore, before changing portn for output mode, make sure the Portn Data Register is set to output a "H."

Unless this precaution is followed, port output may go "L" at the same time the port is set for output after the oscillation has stabilized, causing the microcomputer to enter RAM backup mode.

### 19.3.4 Power-On Limitation

When powering on, make sure to meet the limitation  $VDDE \geq VCCER$ . If  $VDDE$  is 3.0 V or more, there will be no problem even when the limitation  $VDDE \geq VCCER$  cannot be met.

When the above power-on limitation cannot be met, sufficient evaluation must be made during system design in order to ensure that no power will be applied to the microcomputer with a potential difference of 1 V or more. For potential differences 0 V to 0.6 V, there is almost no in-flow current. The amount of in-flow current begins to increase when the potential difference exceeds 0.6 V.

## 19.4 Exiting RAM Backup Mode (Wakeup)

The processing to place the M32R/ECU out of RAM backup mode and return it to normal operation mode is referred to as “wakeup” processing. Figure 19.4.1 shows an example of wakeup processing.

Wakeup processing is initiated by applying a reset. The following shows how to execute wakeup processing.

- (1) Reset the microcomputer ((a) in Figure 19.4.1).
- (2) Set portn for output mode and output a "H" from the port ((b) in Figure 19.4.1) (Note 1)
- (3) Compare the RAM content against the RAM check data created before entering RAM backup mode ((c) in Figure 19.4.1).
- (4) If the comparison in (3) did not match, initialize the RAM ((d) in Figure 19.4.1).  
If the comparison in (3) matched, use the retained data in the program.
- (5) Initialize each internal circuit ((e) in Figure 19.4.1) before returning to the main routine ((f) in Figure 19.4.1).

Note 1: For wakeup from power outage RAM backup mode, portn settings are unnecessary.

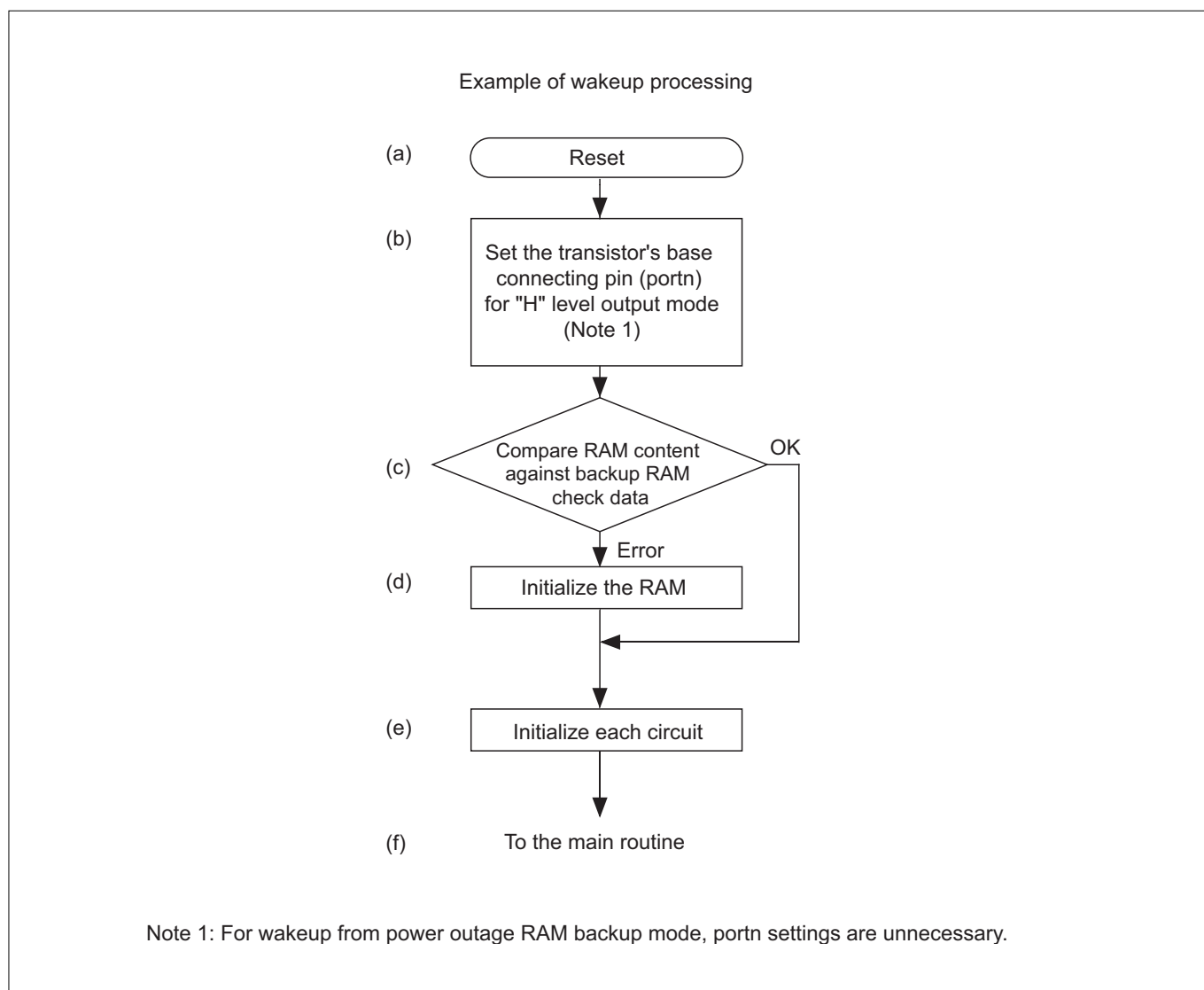


Figure 19.4.1 Wakeup Processing

This page is blank for reasons of layout.

## **CHAPTER 20**

---

# **OSCILLATOR CIRCUIT**

20.1 Oscillator Circuit

20.2 Clock Generator Circuit

## 20.1 Oscillator Circuit

The M32R/ECU contains an oscillator circuit that supplies operating clocks for the M32R-FPU core, internal peripheral I/O and internal memory. The frequency supplied to the clock input pin (XIN) is multiplied by 8 by an internal PLL circuit to produce the CPU clock, which is the operating clock for the M32R-FPU core and internal memory. The frequency of this clock is divided by 4 in the subsequent circuit to produce the peripheral clock, which is the operating clock for the internal peripheral I/O and external data bus.

### 20.1.1 Example of an Oscillator Circuit

An oscillator circuit can be configured by connecting a ceramic (or crystal) resonator between the XIN and XOUT pins external to the chip. Figure 20.1.1 shows an example of a system clock generating circuit using a resonator connected external to the chip. For the constants  $R_f$ ,  $C_{in}$ ,  $C_{out}$  and  $R_d$ , the resonator manufacturer should be consulted to determine the appropriate values.

To use an externally sourced clock signal without using an internal oscillator circuit, connect the external clock signal to the XIN pin and leave the XOUT pin open.

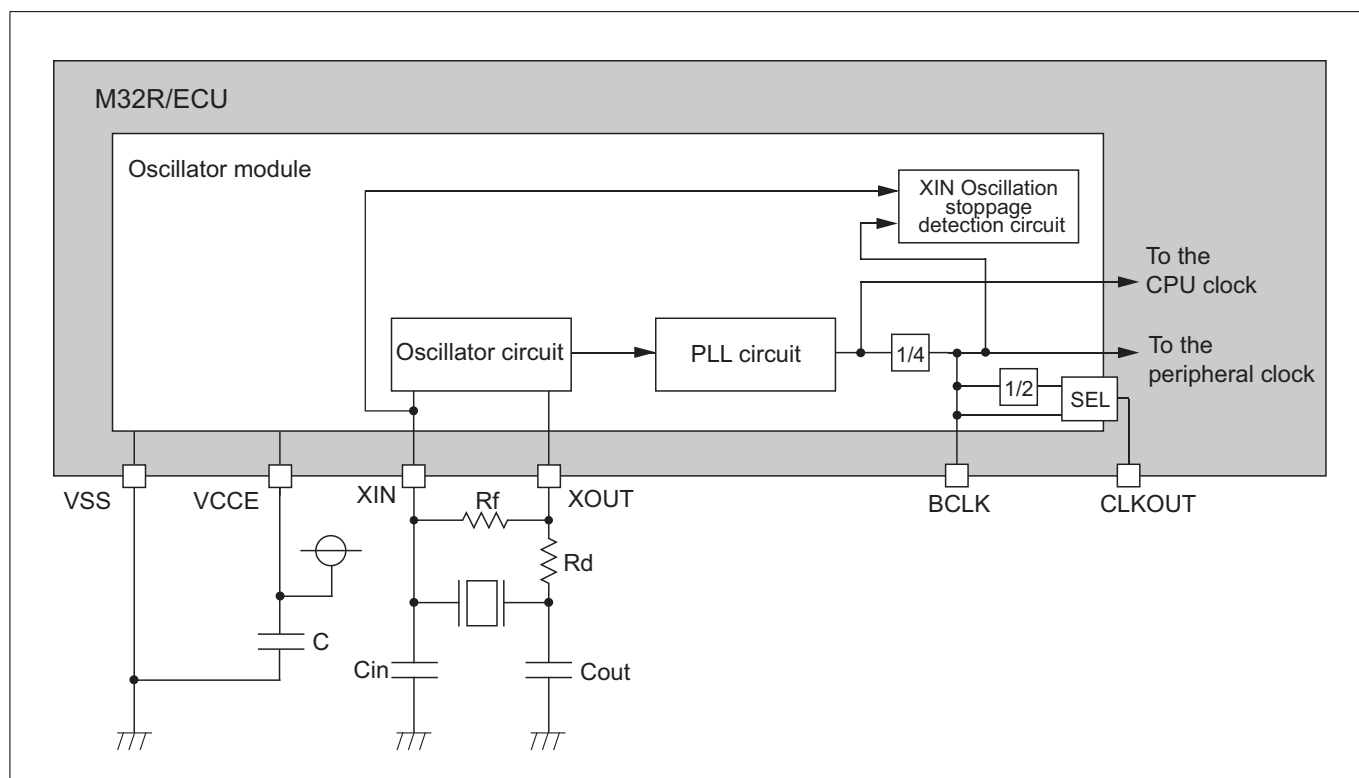


Figure 20.1.1 Example of an Oscillator Circuit

#### 20.1.2 XIN Oscillation Stoppage Detection Circuit

The M32R/ECU contains a detection circuit to find whether oscillation input to the PLL circuit has stopped. The PLL circuit oscillates with the frequency of its normal mode of vibration in the absence of the reference oscillation input. The XIN oscillation input is sampled at the peripheral clock and when the XIN oscillation is found to be at the same level, the XSTAT bit is set. Because the CPU continues operating with the PLL circuit's natural frequency even when the XIN oscillation has stopped, error handling for the stoppage of XIN oscillation can be accomplished by inspecting XSTAT bit in software.

For details about the value of XIN Oscillation Stoppage Detection, see Chapter 23, "ELECTRICAL CHARACTERISTICS."

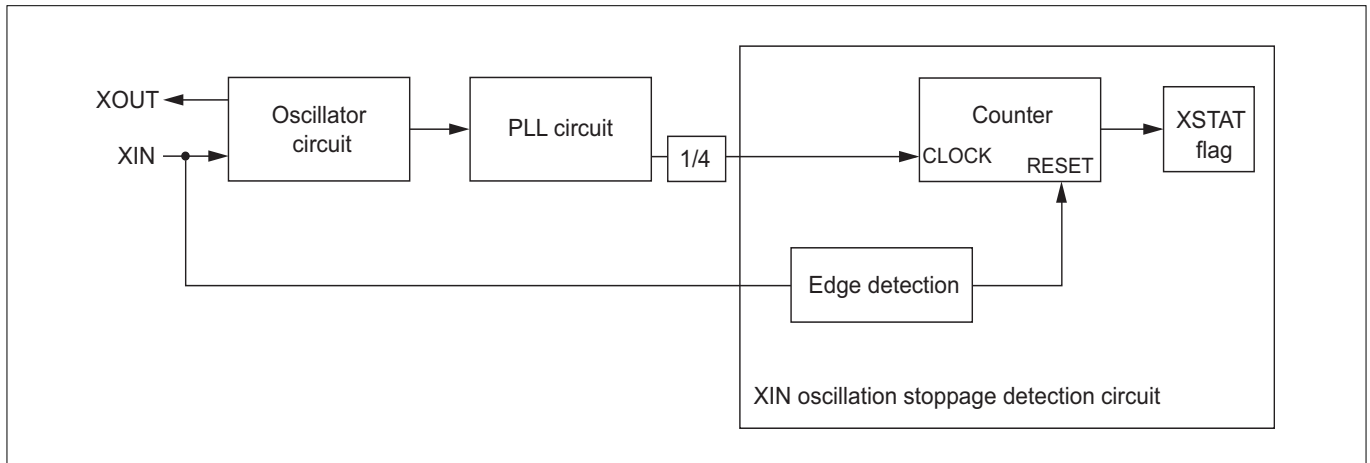


Figure 20.1.2 Block Diagram of the XIN Oscillation Stoppage Detection Circuit

Port Input Special Function Control Register (PICNT)

<Address: H'0080 0745>

b8	9	10	11	12	13	14	b15
0	0	0	XSTAT 0	0	0	PISEL 0	PIEN0 0

<Upon exiting reset: H'00>

b	Bit Name	Function	R	W
8–10	No function assigned. Fix to "0."		0	0
11	XSTAT XIN oscillation status bit	0: XIN oscillating 1: XIN inactive	R	(Note1)
12, 13	No function assigned. Fix to "0."		0	0
14	PISEL Port input data select bit	0: Content of port output latch 1: Port pin level	R	W
15	PIEN0 Port input enable bit	0: Disable input 1: Enable input	R	W

Note 1: Only writing "0" is effective. Writing "1" has no effect; the bit retains the value it had before the write.

For details about the function of the port input data select bit (PISEL) and port input enable bit (PIEN0), see Chapter 8, "Input/Output Ports and pin functions."

**(1) XSTAT (XIN oscillation status) bit**

- **Conditions under which XSTAT bit is set to "1"**

XSTAT bit is set to "1" upon detecting that XIN oscillation has stopped. When XIN remains at the same level on the basis of threshold value for XIN Oscillation Stoppage Detection (3 BCLK periods up to 4 BCLK periods), XIN oscillation is assumed to have stopped. When operating normally, XIN changes state ("H" or "L") once every BCLK period.

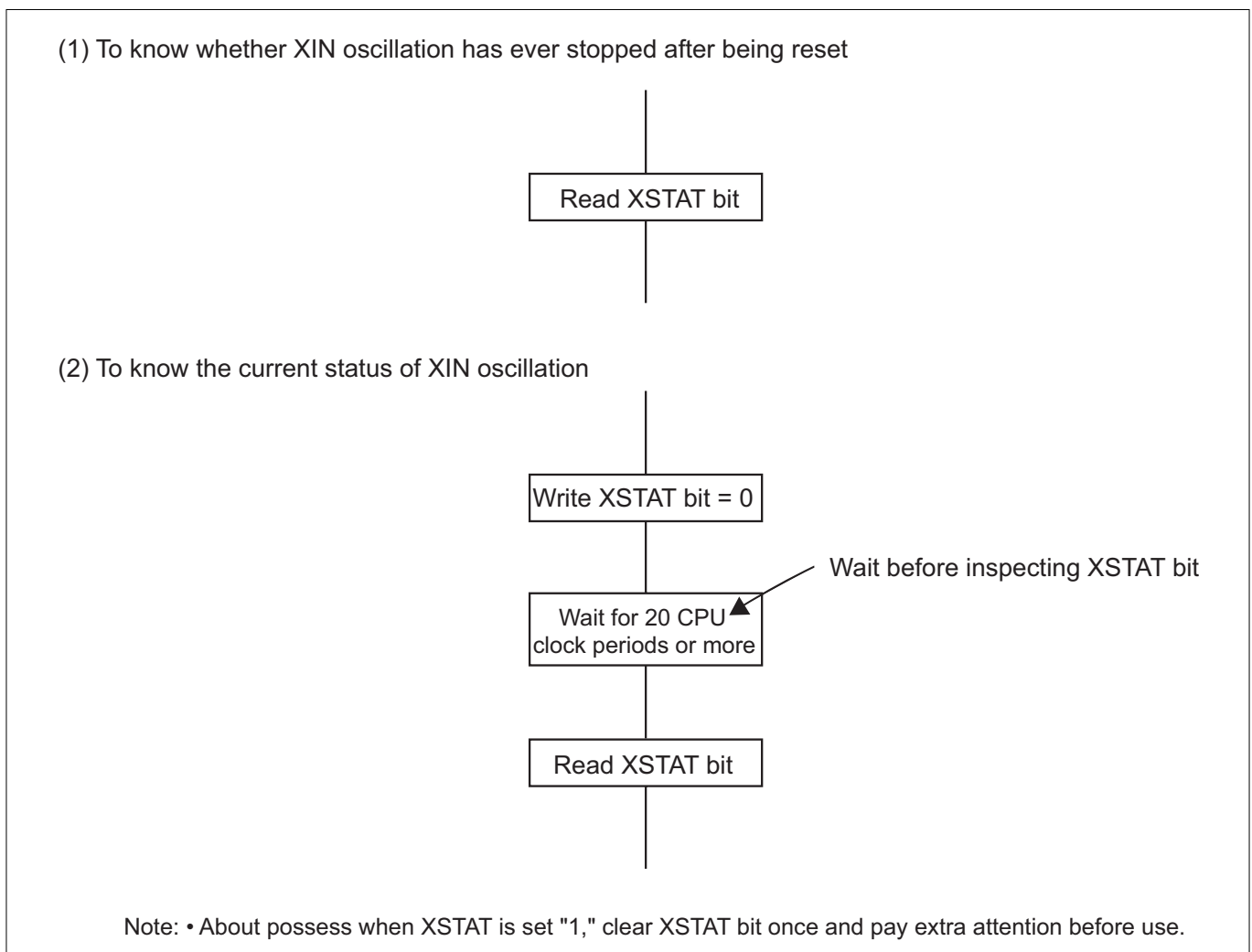
- **Conditions under which XSTAT bit is cleared to "0"**

XSTAT bit is cleared to "0" by a system reset or by writing "0." If XSTAT bit is cleared at the same time it is set in 1) above, the former has priority so that XSTAT bit is cleared. Writing "1" to XSTAT bit is ignored.

- **Method for using XSTAT bit to detect XIN oscillation stoppage**

Because internally contains a PLL, the internal clock remains active even when XIN oscillation has stopped. By reading XSTAT bit without clearing it after exiting the reset state, it is possible to know whether XIN has ever stopped since the reset signal was deasserted. Similarly, by reading XSTAT bit after clearing it by writing 0, it is possible to know the current oscillating status of XIN. (However, there must be an interval of at least 5 BCLK periods (20 CPU clock periods) between read and write.)

About possess when XSAT bit is set "1," clear XSTAT bit once (etc) pay extra attention before use.



**Figure 20.1.3 Procedure for Setting XSTAT bit**



### 20.1.3 Oscillation Drive Capability Select Function

The microcomputer incorporates a four-stage drive capability select function.

Once the oscillation of the oscillator circuit has stabilized, the XIN-XOUT drive capability can be lowered. The lower the drive capability, the smaller the amount of power consumption.

Clock Control Register (CLKCR)

<Address: H'0080 0786>

b0	1	2	3	4	5	6	b7
0	0	0	0	0	XDRVP 0	XDRV 1	1

<Upon exiting reset: H'03>

b	Bit Name	Function	R	W
0-4	No function assigned. Fix to "0."		0	0
5	XDRVP XDRV write control bit		0	W
6, 7	XDRV XIN-XOUT drive capability select bit	XIN-XOUT drive capability (performance ratio) 00: Low                    0.25 01: ↑                        0.50 10: ↓                        0.75 11: High                    1.00	R	W

#### (1) XDRVP (XDRV Write Control) bit (Bit 5)

This bit controls writing to the XIN-XOUT drive capability select bits.

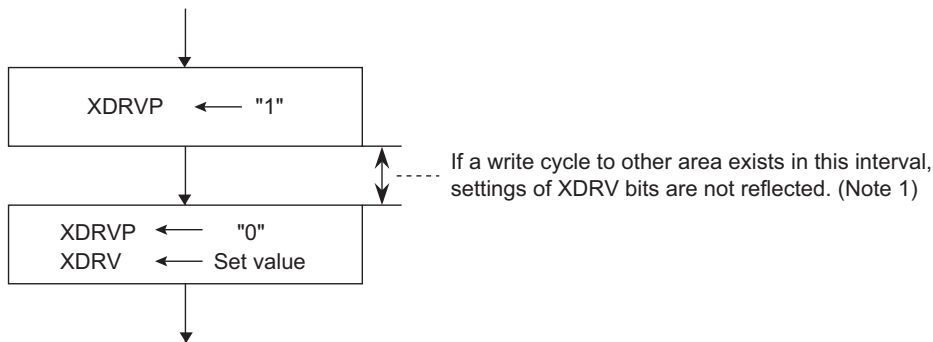
#### (2) XDRV (XIN-XOUT Drive Capability Select) bits (Bits 6, 7)

The following shows the procedure for writing to these bits.

1. Set the write control bit (XDRVP) to "1."
2. Immediately following the above, reset the write control bit (XDRVP) to "0" and write the appropriate value to the XIN-XOUT drive capability select bits.

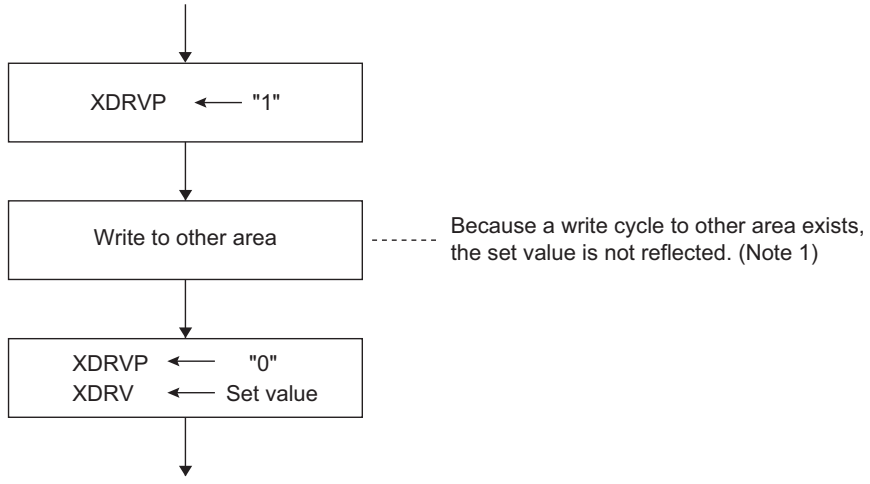
- Notes:
- If there are writing cycles from CPU, DMA, SDI (tool), NBD to any other area between 1 and 2, the continuous setting (A pair of two consecutive is 1 set for writing operation) is disabled and the writing value is not reflected. Therefore, disable interrupts and DMA transfers before setting. However the writing cycle from RTD and DRI are not effected.
  - When you input external clocks other than resonator or oscillator, make XOUT pin open and XIN-XOUT drive capability high(maximum) is selected in XDRV bit.

• Example of correct setting

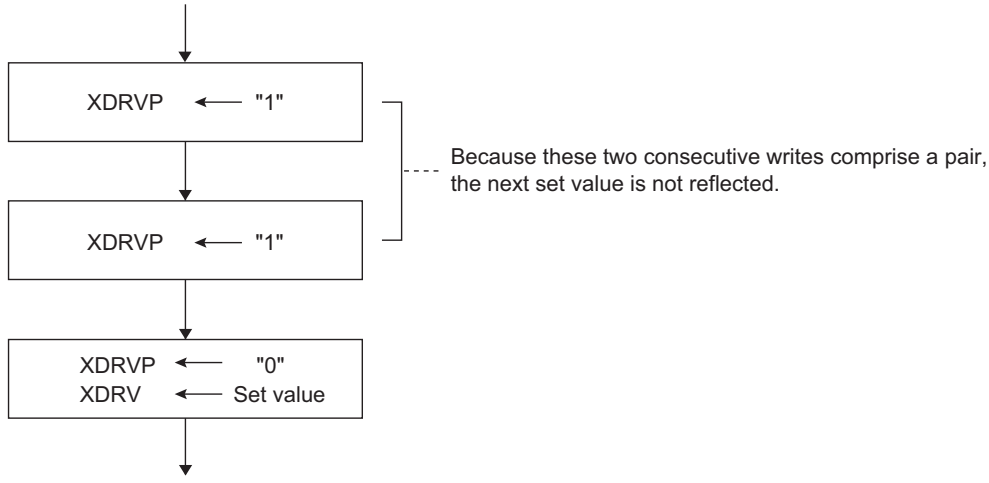


• Settings that do not have effect

(1)



(2)



Note 1: The writing cycle to the other area is the writing cycle from CPU, DMA, SDI (tool), NBD to any other area. The writing cycle from RTD and DRI do not effect.

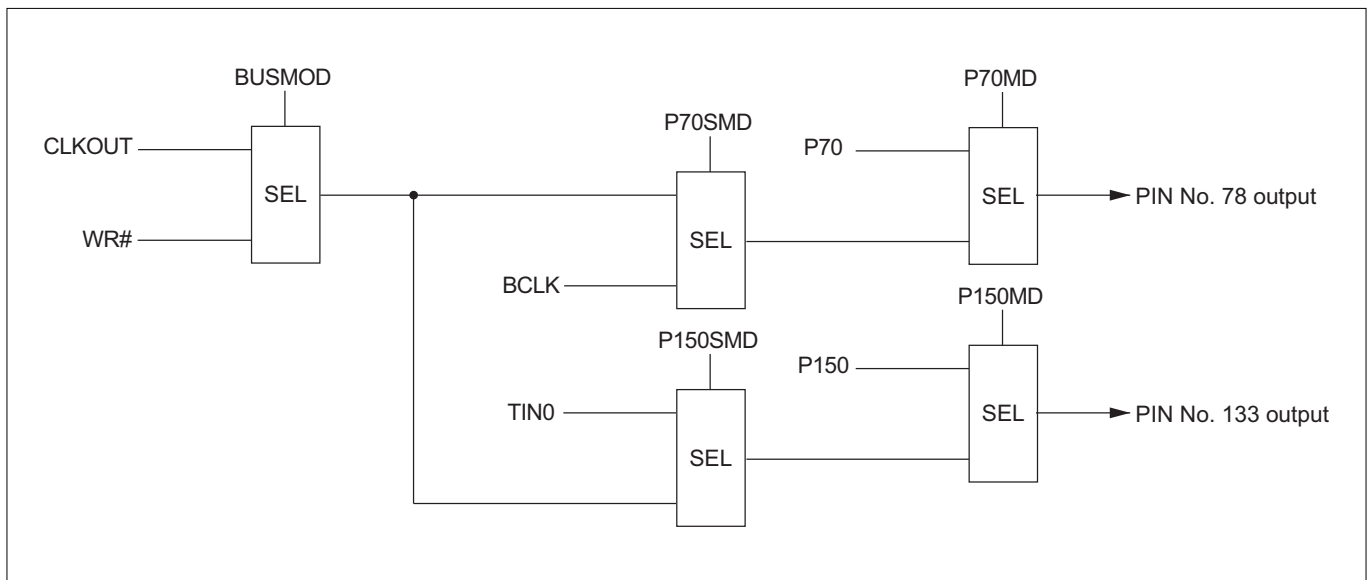
Figure 20.1.4 Procedure for Setting the Oscillation Drive Capability

#### 20.1.4 System Clock Output Function

A clock twice the frequency of the input clock, i.e., a peripheral clock, can be output from the BCLK pin. This peripheral clock, either directly or after being divided by 2, can be output as an external bus clock from the CLKOUT pin. This BCLK pin is shared with port P70. The CLKOUT pin is shared with port P70 or port P150. The output pins for the peripheral clock BCLK and the external bus clock CLKOUT are listed in Table 20.1.1. A CLKOUT and BCLK select structure is shown in Figure 20.1.5.

**Table 20.1.1 Output Pins for CLKOUT and BCLK**

PIN No.	Pin Name	Function	Set Value
78	P70/CLKOUT/WR#/BCLK	P70	P70MD=0
		CLKOUT	P70MD=1, P70SMD=0, BUSMOD=0
		WR#	P70MD=1, P70SMD=0, BUSMOD=1
		BCLK	P70MD=1, P70SMD=1
133	P150/TIN0/CLKOUT/WR#	P150	P150MD=0
		TIN0	P150MD=1, P150SMD=0
		CLKOUT	P150MD=1, P150SMD=1, BUSMOD=0
		WR#	P150MD=1, P150SMD=1, BUSMOD=1



**Figure 20.1.5 A CLKOUT and BCLK Select Structure**

The external bus clock can be selected from BCLK and BCLK divided by two by using CLKOUT Select Register.

CLKOUT Select Register (CLKOUTSEL)

<Address: H'0080 01A0>

b0	1	2	3	4	5	6	b7
0	0	0	0	0	0	CLKOSELP	CLKOSEL
						0	0

<Upon exiting reset: H'00>

b	Bit Name	Function	R	W
0–5	No function assigned. Fix to"0."		0	0
6	CLKOSELP CLKOSEL write control bit		0	W
7	CLKOSEL CLKOUT select bit	0: BCLK divided by 2 1: BCLK	R	W

Notes: • At the timing for CLKOUT changes from divided-by-2 BCLK to straight BCLK or vice versa, there will be some indefinite output.

- When BCLK is selected as a CLKOUT terminal output, regardless of CS0-CS3 is used or not, it is prohibition that selecting 0 wait in WAIT (the number selection of internal wait) bit of a CSn area wait control register.

### (1) CLKOSEL (CLKOSEL Write Control) bit (Bit 6)

This bit controls write to the CLKOUT select bit.

### (2) CLKOSEL (CLKOUT Select) bit (Bit 7)

This bit selects straight BCLK or divided-by-2 BCLK as outputting of CLKOUT (external bus synchronous clock) pin. If the CPU clock is 160 MHz, BCLK is 40 MHz. If CLKOSEL is cleared to "0," CLKOUT or the external bus reference clock is 20 MHz; if CLKOSEL is set to "1," CLKOUT is 40 MHz. The number of wait states set by the CSn area control register, as well as CS wait, strobe wait, recovery cycles and idle cycles after read all are synchronized to CLKOUT.

However when "1" is selected in CLKOSEL bit (BCLK is selected as a CLKOUT terminal output), regardless of CS0–CS3 is used or not, it is prohibition that selecting 0 wait in WAIT (the number selection of internal wait) bit of a CSn area wait control register.

The following describes how to set the CLKOSEL (CLKOUT select ) bit (See Figure 17.2.2.)

1. The program in the internal ROM or the internal RAM should be used to set the bits.
2. Write "1" to the CLKOSEL write control bit (CLKOSELP).
3. Subsequent to 2 above, write "0" to the CLKOSEL write control bit (CLKOSELP) and then "0" or "1" whichever desired to the CLKOUT select bit (CLKOSEL).
4. After writing to the above bits, access any SFR area for read twice.

The following shows configurations for P7 Operation Mode Register, P7 Peripheral Function Select Register, P15 Operation Mode Register and P15 Peripheral Function Select Register.

## P7 Operation Mode Register (P7MOD)

&lt;Address: H'0080 0747&gt;

b8	9	10	11	12	13	14	b15
P70MD	P71MD	P72MD	P73MD	P74MD	P75MD	P76MD	P77MD
0	0	0	0	0	0	0	0

&lt;Upon exiting reset: H'00&gt;

b	Bit Name	Function	R	W
8	P70MD Port P70 operation mode bit	0: P70 1: CLKOUT/WR#/BCLK (Note 1)	R	W
9	P71MD Port P71 operation mode bit	0: P71 1: WAIT# (Note 2)	R	W
10	P72MD Port P72 operation mode bit	0: P72 1: HREQ#/TIN27 (Note 3)	R	W
11	P73MD Port P73 operation mode bit	0: P73 1: HACK#/TIN26 (Note 3)	R	W
12	P74MD Port P74 operation mode bit (Note 4)	0: P74 1: RTDXTD/TXD3 (Note 3)	R	W
13	P75MD Port P75 operation mode bit (Note 4)	0: P75 1: RTDRXD/RXD3 (Note 3)	R	W
14	P76MD Port P76 operation mode bit (Note 4)	0: P76 1: RTDACK/CTX1 (Note 3)	R	W
15	P77MD Port P77 operation mode bit (Note 4)	0: P77 1: RTDCLK/CRX1 (Note 3)	R	W

Note 1: These functions are selected using the P7 Peripheral Function Select Register and Bus Mode Control Register.

Note 2: During single-chip mode, settings of this register have no effect, and the port functions as port input/output pin.

Note 3: These functions are selected using the P7 Peripheral Function Select Register.

Note 4: If the NBD function is selected by the NBD Pin Control Register, the port functions as NBD pin no matter how this register is set.

## P7 Peripheral Function Select Register (P7SMOD)

&lt;Address: H'0080 0767&gt;

b8	9	10	11	12	13	14	b15
P70SMD		P72SMD	P73SMD	P74SMD	P75SMD	P76SMD	P77SMD
0	0	0	0	0	0	0	0

&lt;Upon exiting reset: H'00&gt;

b	Bit Name	Function	R	W
8	P70SMD Port P70 peripheral function select bit	0: CLKOUT/WR# (Note 1) 1: BCLK	R	W
9	No function assigned. Fix to "0."		0	0
10	P72SMD Port P72 peripheral function select bit	0: HREQ# 1: TIN27	R	W
11	P73SMD Port P73 peripheral function select bit	0: HACK# 1: TIN26	R	W
12	P74SMD (Note 2) Port P74 peripheral function select bit	0: RTDXTD 1: TXD3	R	W
13	P75SMD (Note 2) Port P75 peripheral function select bit	0: RTDRXD 1: RXD3	R	W
14	P76SMD (Note 2) Port P76 peripheral function select bit	0: RTDACK 1: CTX1	R	W
15	P77SMD (Note 2) Port P77 peripheral function select bit	0: RTDCLK 1: CRX1	R	W

Note 1: Which function of the pin is used depends on how the Bus Mode Control Register is set.

Note 2: If the NBD function is selected by the NBD Pin Control Register, the port functions as NBD pin no matter how this register is set.

Note: • The value of this register can only be modified when the corresponding P7 operation mode register bit = 0 (set for port).

Then set the corresponding P7 operation mode register bit to "1."

## P15 Operation Mode Register (P15MOD)

&lt;Address: H'0080 074F&gt;

b8	9	10	11	12	13	14	b15
P150MD			P153MD				
0	0	0	0	0	0	0	0

&lt;Upon exiting reset: H'00&gt;

b	Bit Name	Function	R	W
8	P150MD Port P150 operation mode bit	0: P150 1: TIN0/CLKOUT/WR# (Note 1)	R	W
9, 10	No function assigned. Fix to "0."		0	0
11	P153MD Port P153 operation mode bit	0: P153 1: TIN3/WAIT# (Note 2)	R	W
12–15	No function assigned. Fix to "0."		0	0

Note 1: Which function of the pin is used depends on how the P15 Peripheral Function Select Register and Bus Mode Control Register are set.

Note 2: Which function of the pin is used depends on how the P15 Peripheral Function Select Register is set.

## P15 Peripheral Function Select Register (P15SMD)

&lt;Address: H'0080 076F&gt;

b8	9	10	11	12	13	14	b15
P150SMD			P153SMD				
0	0	0	0	0	0	0	0

&lt;Upon exiting reset: H'00&gt;

b	Bit Name	Function	R	W
8	P150SMD Port P150 peripheral function select bit	0: TIN0 1: CLKOUT/WR# (Note 1)	R	W
9, 10	No function assigned. Fix to "0."		0	0
11	P153SMD Port P153 peripheral function select bit (Note 2)	0: TIN3 1: WAIT#	R	W
12–15	No function assigned. Fix to "0."		0	0

Note 1: Which function of the pin is used depends on how the Bus Mode Control Register is set.

Note 2: During single-chip mode, selecting the external bus interface signal function is prohibited.

Note: • The value of this register can only be modified when the corresponding P15 operation mode register bit = 0 (set for port). Then set the corresponding P15 operation mode register bit to "1."

#### 20.1.5 Oscillation Stabilization Time at Power-On

The oscillator circuit comprised of a ceramic (or crystal) resonator requires a finite time before its oscillation stabilizes after being powered on. Therefore, there must be a certain amount of oscillation stabilization time that suits the oscillator circuit used.

Figure 20.1.6 shows an oscillation stabilization time required at power-on.

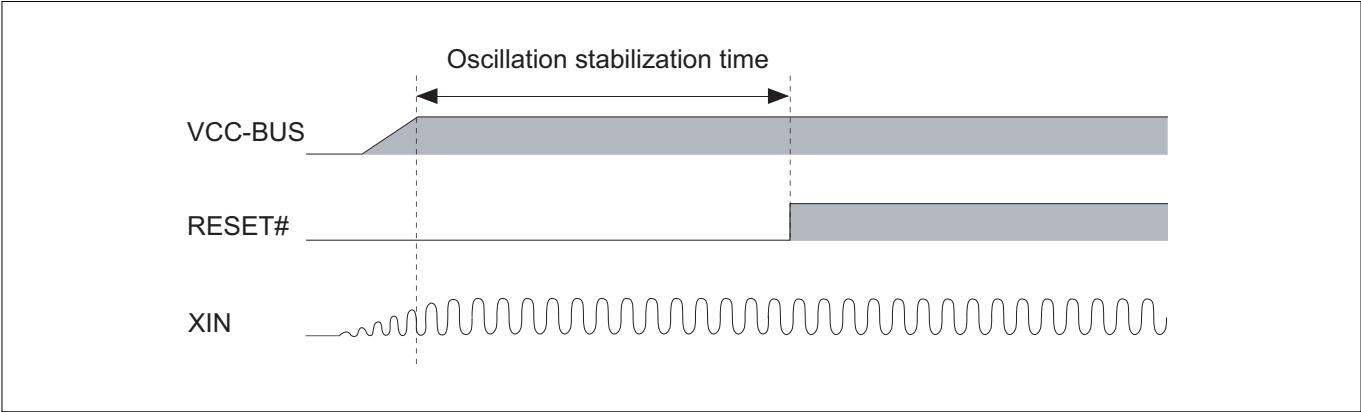


Figure 20.1.6 Oscillation Stabilization Time at Power-On

## 20.2 Clock Generator Circuit

Supply independent clocks to the CPU and the internal peripheral circuit.

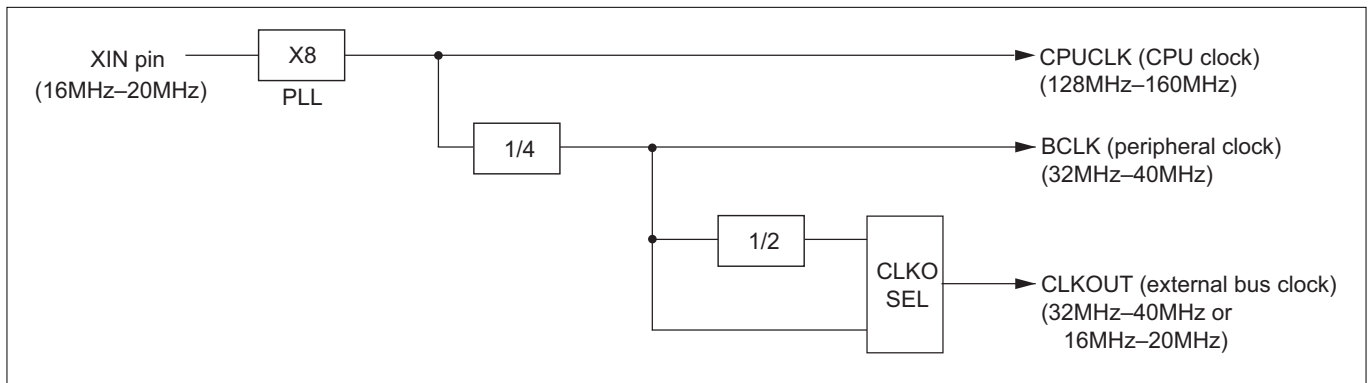


Figure 20.2.1 Conceptual Diagram of Clock Generation



# CHAPTER 21

---

## JTAG

- 21.1 Outline of JTAG
- 21.2 Configuration of JTAG Circuit
- 21.3 JTAG Registers
- 21.4 Basic Operation of JTAG
- 21.5 Boundary Scan Description Language
- 21.6 Notes on Board Design when Connecting JTAG
- 21.7 Processing Pins when Not Using JTAG

## 21.1 Outline of JTAG

The M32R/ECU contains a JTAG (Joint Test Action Group) interface compliant with IEEE Standard Test Access Port and Boundary-Scan Architecture (IEEE Std. 1149.1a-1993). This JTAG interface can be used as an input/output path for boundary-scan test (boundary-scan path). For details about IEEE 1149.1 JTAG test access ports, see IEEE Std. 1149.1a-1993 documentation.

Note: • The JTAG interface in the M32R/ECU is used to connect a JTAG emulator during debugging as well. In this chapter, the JTAG interface is explained assuming its use as an input/output path for boundary-scan test.

Functions of the JTAG interface-related pins mounted on the M32R/ECU are shown below.

**Table 21.1.1 JTAG Pin Functions**

Type	Pin Name	Signal Name	I/O	Function
TAP	JTCK	Test clock	Input	Clock input to the test circuit.
(Note 1)	JTDI	Test data Input	Input	Synchronous serial data input pin used to supply the test instruction code and test data. This input is sampled on the rising edge of JTCK.
	JTDO	Test data Output	Output	Synchronous serial data output pin used to output the test instruction code and test data. This signal changes state on the falling edge of JTCK, and is output in only the Shift-IR or Shift-DR state. Otherwise, it goes to a high-impedance state.
	JTMS	Test mode select	Input	Test mode select input to control the test circuit's state transition. This input is sampled on the rising edge of JTCK.
	JTRST	Test reset	Input	Active "L" test reset input to initialize the test circuit asynchronously. To ensure that the test circuit is reset without fail, JTMS input signal must be held high while this signal changes state from "L" to "H".

Note: TAP stands for Test Access Port (JTAG interface specified in IEEE 1149.1).

## 21.2 Configuration of JTAG Circuit

The JTAG circuit consists of the following circuit blocks.

- Instruction register to hold the instruction code that is fetched through the boundary-scan path
- A set of registers which are accessed through the boundary-scan path
- Test access port (abbreviated TAP) controller to control the JTAG unit's state transition
- Control logic to select input, output, etc.

The figure below shows the configuration of the JTAG circuit.

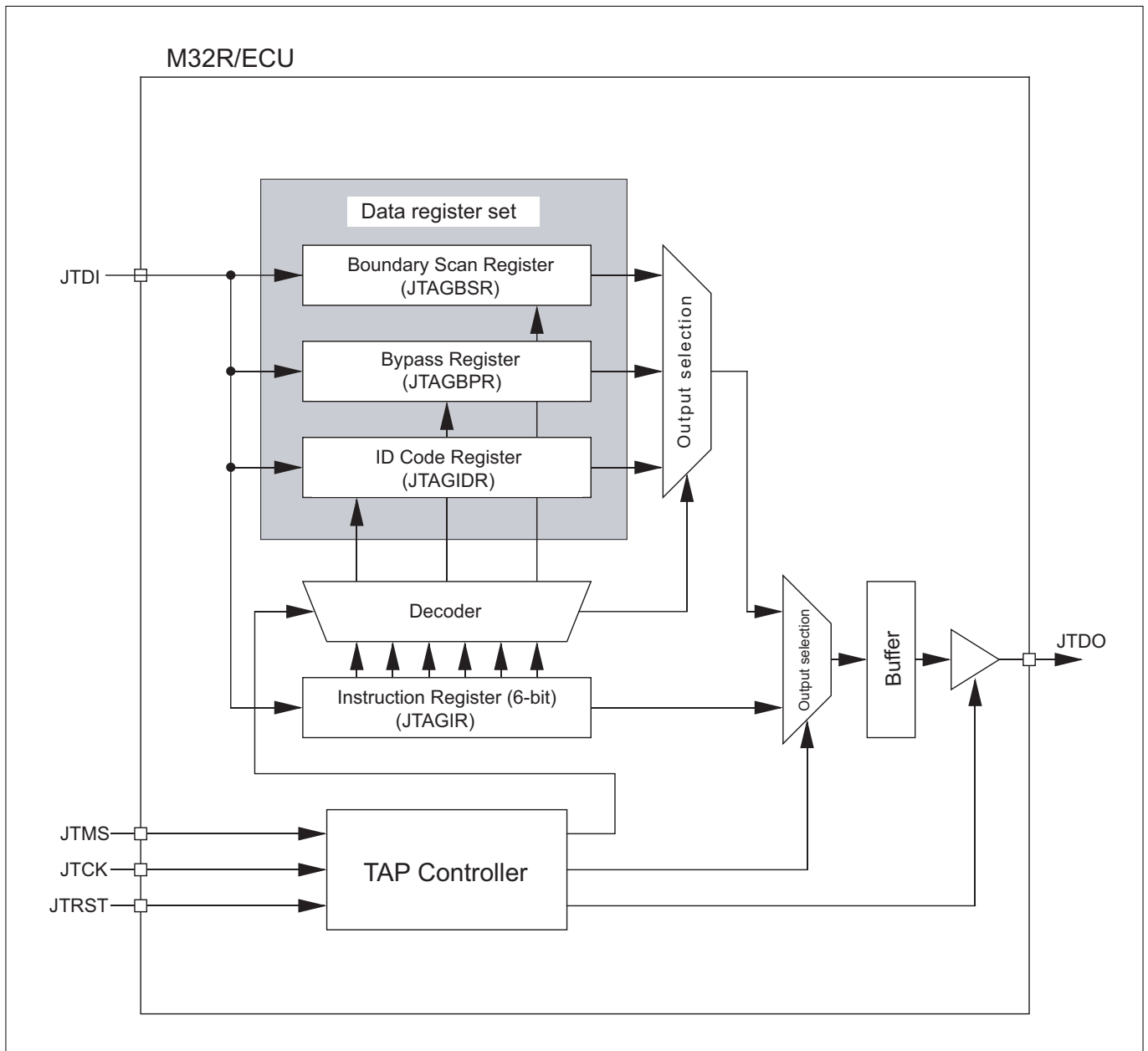


Figure 21.2.1 Configuration of the JTAG Circuit

## 21.3 JTAG Registers

### 21.3.1 Instruction Register (JTAGIR)

The Instruction Register is a 6-bit register to hold instruction code. This register is set in the IR path sequence. The instructions set in this register determine the data register to be selected in the subsequent DR path sequence.

The initial value of this register after test is reset (to initialize the test circuit) is b'000010 (IDCODE instruction). After a test reset, the ID Code Register is selected as the data register until instruction code is set by an external device. In the Capture-IR state, this register always has b'110001 (fixed value) loaded into it. Therefore, when in the Shift-IR state, no matter what value was set in this register, the value b'110001 is always output from the JTDO pin (sequentially beginning with the LSB). However, this value normally is not handled as instruction code.

Shown below is outside the scope of guaranteed operations. If this operation is attempted, the microcomputer may handle b'110001 as instruction code, which makes the microcomputer unable to operate normally.

Capture-IR → Exit1-IR → Update-IR

Following instructions are supported for the JTAG interface of the M32R/ECU:

- Three instructions specified as essential in IEEE 1149.1 (EXTEST, SAMPLE/PRELOAD, BYPASS)
- Device identification register access instruction (IDCODE)

**Table 21.3.1 JTAG Instruction List**

Instruction Code	Abbreviation	Operation
b'000000	EXTEST	Test the circuit/board-level connections external to the chip.
b'000001	SAMPLE/PRELOAD	Sample the operating status of the circuit and output the sampled status from the JTDO pin, while at the same time supplying the data used for boundary-scan test from the JTDI pin and preset it in the Boundary Scan Register.
b'000010	IDCODE	Select the ID Code Register to output the device and manufacturer identification data from the JTDO pin.
b'111111	BYPASS	Select the Bypass Register to inspect or set data.

Notes: • Do not set any other instruction code.

- For details about the IR path sequence, DR path sequence, test reset, Capture-IR state, Shift-IR state, Exit1-IR state and Update-IR state, see Section 21.4, "Basic Operation of JTAG."

### 21.3.2 Data Register

#### (1) Boundary Scan Register (JTAGBSR)

The Boundary Scan Register is a 294-bit register used to perform boundary-scan test. The bits in this register are assigned to each pin on the microcomputer.

Connected between the JTDI and JTDO pins, this register is selected when issuing EXTEST or SAMPLE/PRELOAD instruction. In the Capture-DR state, this register captures the status of input pins or internal logic outputs. In the Shift-DR state, while outputting the sampled value, this register receives the input data for boundary-scan test to set pin functions (direction of input/output and tristate output pins) and output values.

#### (2) Bypass Register (JTAGBPR)

The Bypass Register is a 1-bit register used to bypass the boundary-scan path when the microcomputer is not the target of boundary-scan test. Connected between the JTDI and JTDO pins, this register is selected when issuing BYPASS instruction. This register is loaded with b'0 (fixed value) in the Capture-DR state.

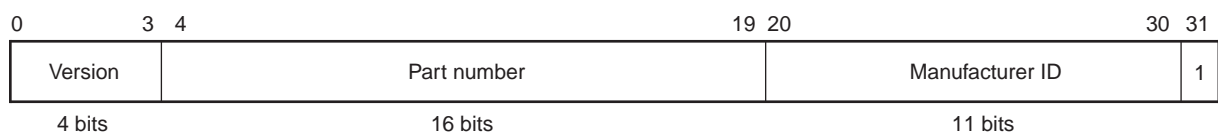
#### (3) ID Code Register (JTAGIDR)

The ID Code Register is a 32-bit register used to identify the device and manufacturer. It holds the following information:

- Version information (4 bits) : b'0000
- Part number (16 bits) : b'0011 0010 0010 0101 (32192)  
: b'0011 0010 0010 0111 (32195)  
: b'0011 0010 0010 0110 (32196)
- Manufacturer ID (11 bits) : b'010 0010 0011

This register is connected between the JTDI and JTDO pins, and is selected when issuing IDCODE instruction. This register is loaded with said IDCODE data in the Capture-DR state, and outputs it from the JTDO pin in the Shift-DR state.

The ID Code Register is a read-only register. Because the data written from the JTDI pin during DR path sequence is ignored, make sure JTDI input = "L" while in the Shift-DR state.



Note: • For details about the Capture-DR and Shift-DR states, see Section 21.4, "Basic Operation of JTAG."

## 21.4 Basic Operation of JTAG

### 21.4.1 Outline of JTAG Operation

The instruction and data registers basically are accessed in conjunction with the following three operations, which are performed based on the TAP Controller's state transition. The TAP Controller changes state according to JTMS input, and generates control signals required for operation in each state.

- **Capture operation**

The result of boundary-scan test or the fixed data defined for each register is sampled. As a register operation, data input is latched into the shift register stage.

- **Shift operation**

The register is accessed from outside through the boundary-scan path. The sample value is output to the outside at the same time data is set from the outside. As a register operation, the bits are shifted right between each shift register stage.

- **Update operation**

The data set from the outside during shifting is driven. As a register operation, the value set in the shift register stage is transferred to the parallel output stage.

The JTAG interface undergoes transition of the internal state depending on JTMS input and on such state transition, it performs the following two operations. In either case, the operation basically is performed in order of Capture → Shift → Update.

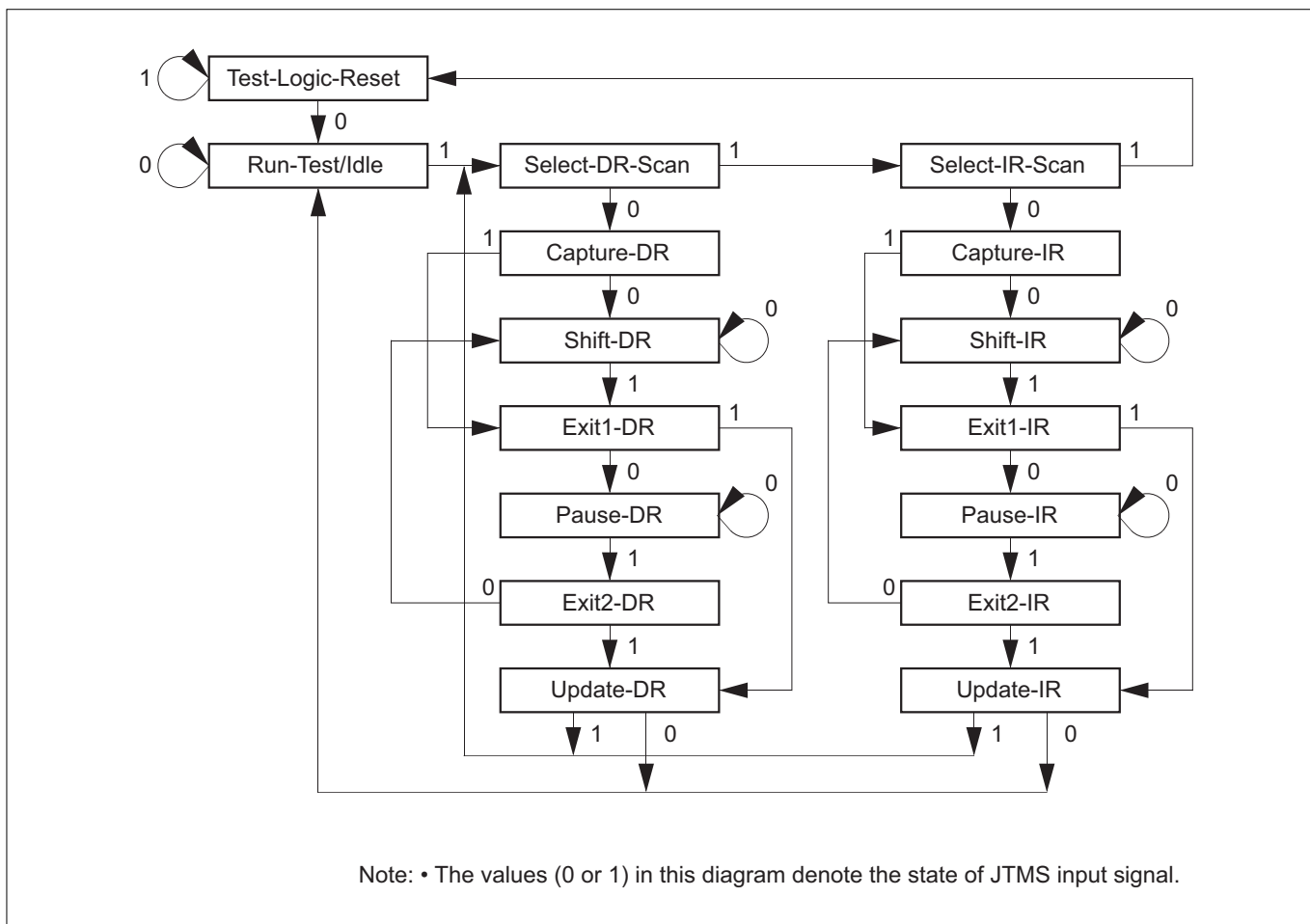
- **IR path sequence**

Instruction code is set in the instruction register to select the data register to be operated on in the subsequent DR path sequence.

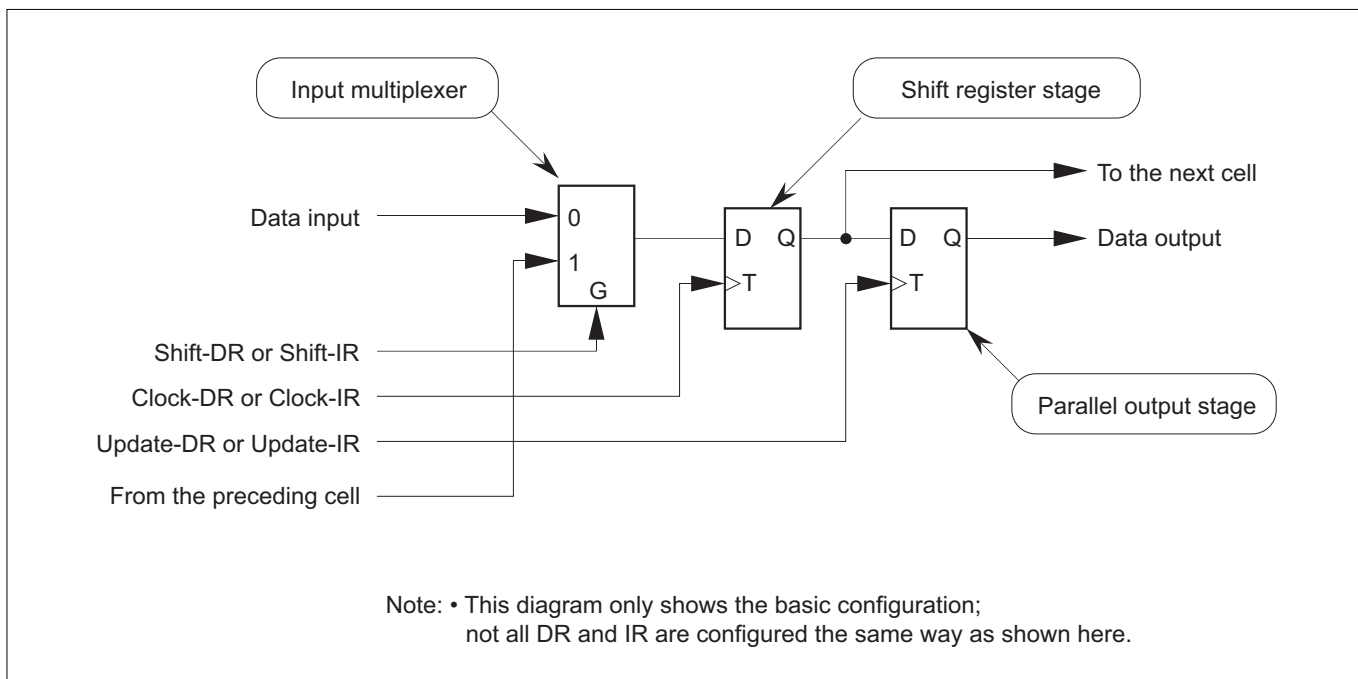
- **DR path sequence**

Data inspection or setting is performed for the selected data register.

The state transition of the TAP Controller and the basic configuration of the JTAG related registers are shown below.



**Figure 21.4.1 TAP Controller State Transition**



**Figure 21.4.2 Basic Configuration of the JTAG Related Registers**

### 21.4.2 IR Path Sequence

Instruction code is set in the Instruction Register (JTAGIR) to select the data register to be accessed in the subsequent DR path sequence. The IR path sequence is performed following the procedure described below.

- (1) From the Run-Test/Idle state, apply JTMS = "H" for a period of 2 JTCK cycles to enter the Select-IR-Scan state.
- (2) Apply JTMS = "L" to enter the Capture-IR state. At this time, b'110001 (fixed value) is set in the Instruction Register's shift register stage.
- (3) Proceed and apply JTMS = "L" to enter the Shift-IR state. In the Shift-IR state, the value of the shift register stage is shifted right one bit every cycle, and the data b'110001 (fixed value) that was set in (2) is serially output from the JTDO pin. At the same time, instruction code is set in the shift register stage bit by bit as it is serially fed from the JTDI pin. Because the instruction code is set in the Instruction Register that consists of 6 bits, the Shift-IR state must be continued for a period of 6 JTCK cycles. To stop the shift operation in the middle of the execution, enter the Pause-IR state via the Exit1-IR state (by setting JTMS input from "H" to "L"). To return from the Pause-IR state, enter the Shift-IR state via the Exit2-IR state (by setting JTMS input from "H" to "L").
- (4) Apply JTMS = "H" to move from the Shift-IR state to the Exit1-IR state. This completes the shift operation.
- (5) Proceed and apply JTMS = "H" to enter the Update-IR state. In the Update-IR state, the instruction code that was set in the Instruction Register's shift register stage is transferred to the Instruction Register's parallel output stage, and decoding of JTAG instruction is thereby started.
- (6) Proceed and apply JTMS = "H" to enter the Select-DR-Scan state or JTMS = "L" to enter the Run-Test/Idle state.

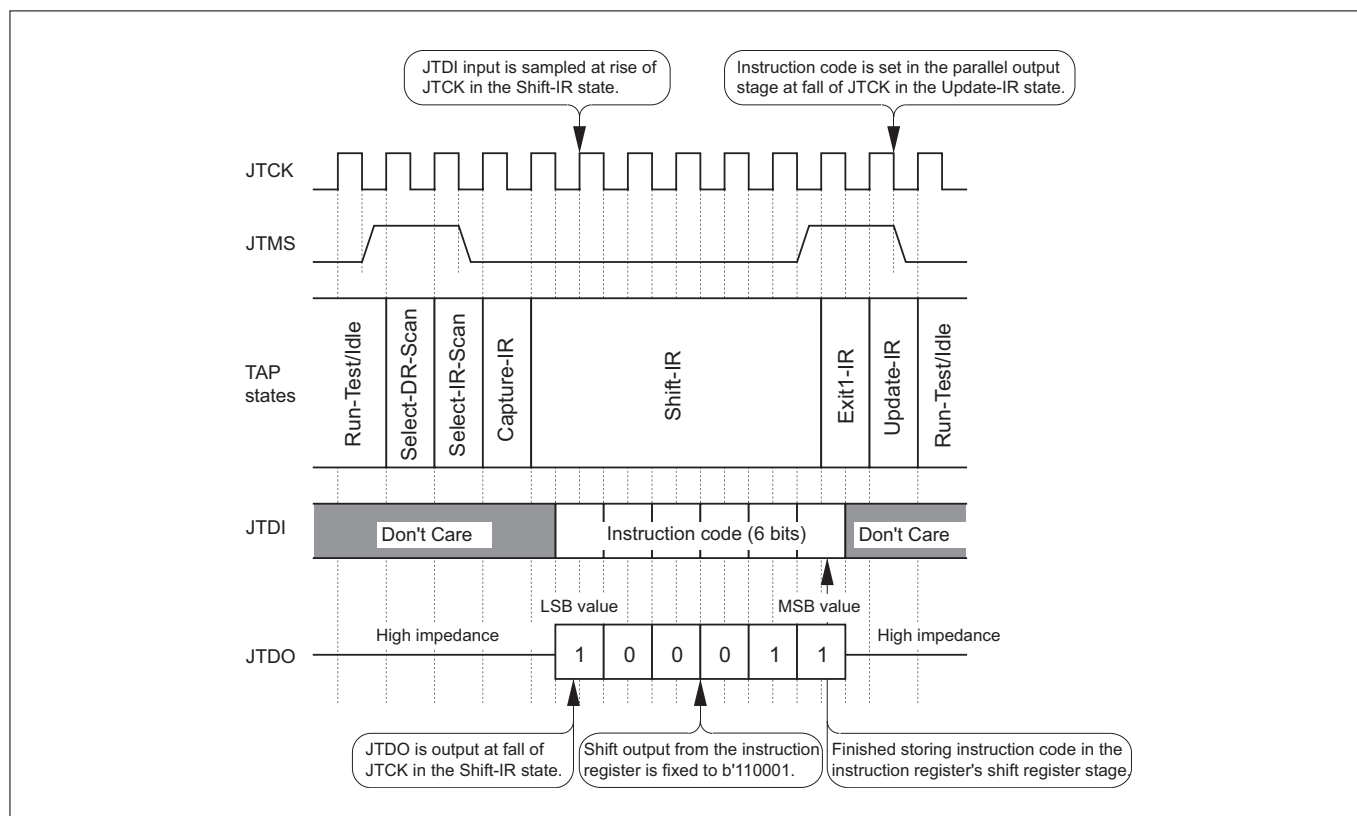


Figure 21.4.3 IR Path Sequence



### 21.4.3 DR Path Sequence

Data inspection or setting is performed for the data register selected in the IR path sequence prior to the DR path sequence. The DR path sequence is performed following the procedure described below.

- (1) From the Run-Test/Idle state, apply JTMS = "H" for a period of 1 JTCK cycle to enter the Select-DR-Scan state. Which data register will be selected at this time depends on the instruction that was set during the IR path sequence performed prior to the DR path sequence.
- (2) Apply JTMS = "L" to enter the Capture-DR state. At this time, the result of boundary-scan test or the fixed data defined for each register is set in the data register's shift register stage.
- (3) Proceed and apply JTMS = "L" to enter the Shift-DR state. In the Shift-DR state, the DR value is shifted right one bit every cycle, and the data that was set in (2) is serially output from the JTDO pin. At the same time, setup data is set in the data register's shift register stage bit by bit as it is serially fed from the JTDI pin. By continuing the Shift-DR state as long as the number of bits that comprise the selected data register (by applying JTMS = "L"), all bits of data can be set in and read out from the shift register stage. To stop the shift operation in the middle of the execution, enter the Pause-DR state via the Exit1-DR state (by setting JTMS input from "H" to "L"). To return from the Pause-DR state, enter the Shift-DR state via the Exit2-DR state (by setting JTMS input from "H" to "L").
- (4) Apply JTMS = "H" to move from the Shift-DR state to the Exit1-DR state. This completes the shift operation.
- (5) Proceed and apply JTMS = "H" to enter the Update-DR state. In the Update-DR state, the data that was set in the data register's shift register stage is transferred to the parallel output stage, and the setup data is thereby made ready for use.
- (6) Proceed and apply JTMS = "H" to enter the Select-DR-Scan state or JTMS = "L" to enter the Run-Test/Idle state.

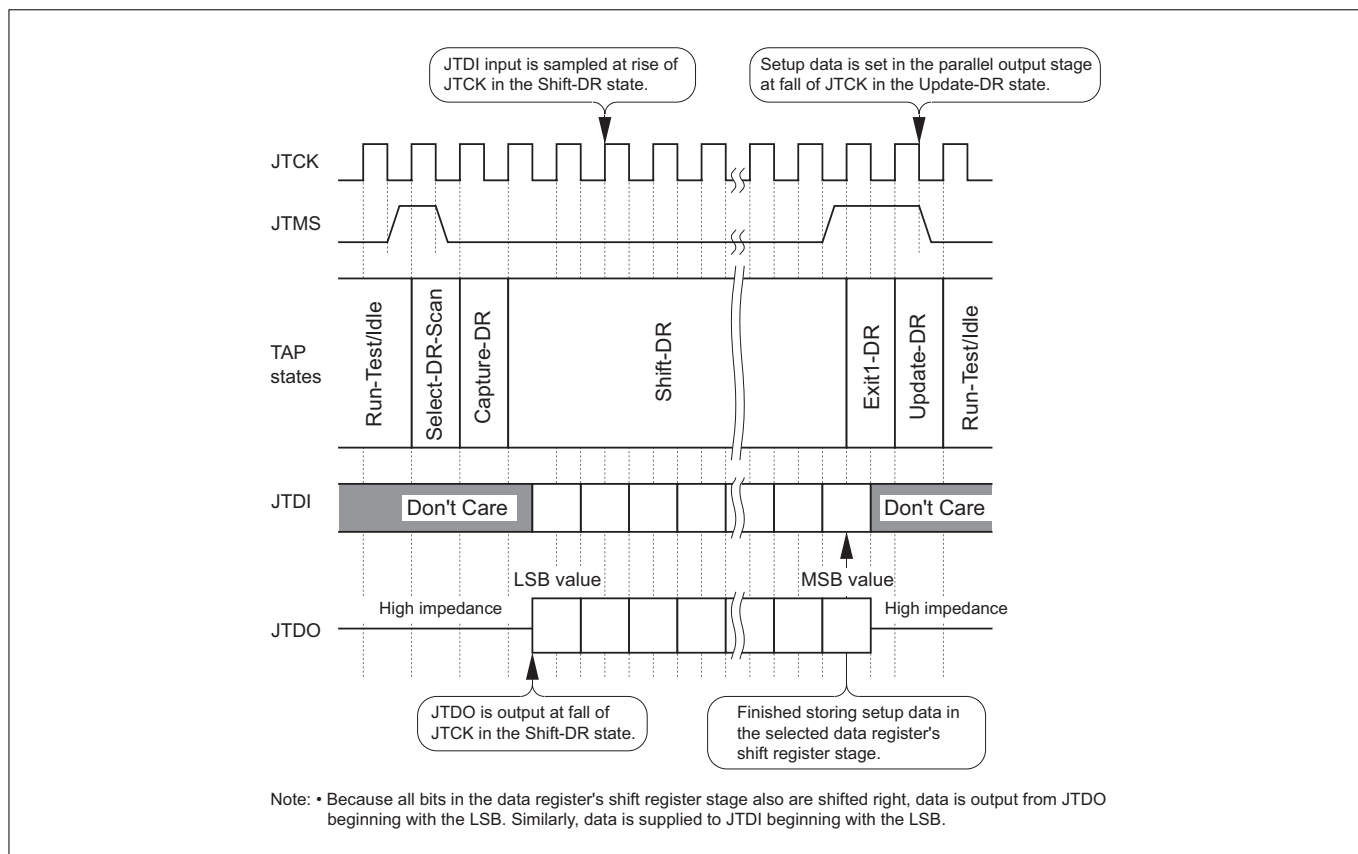
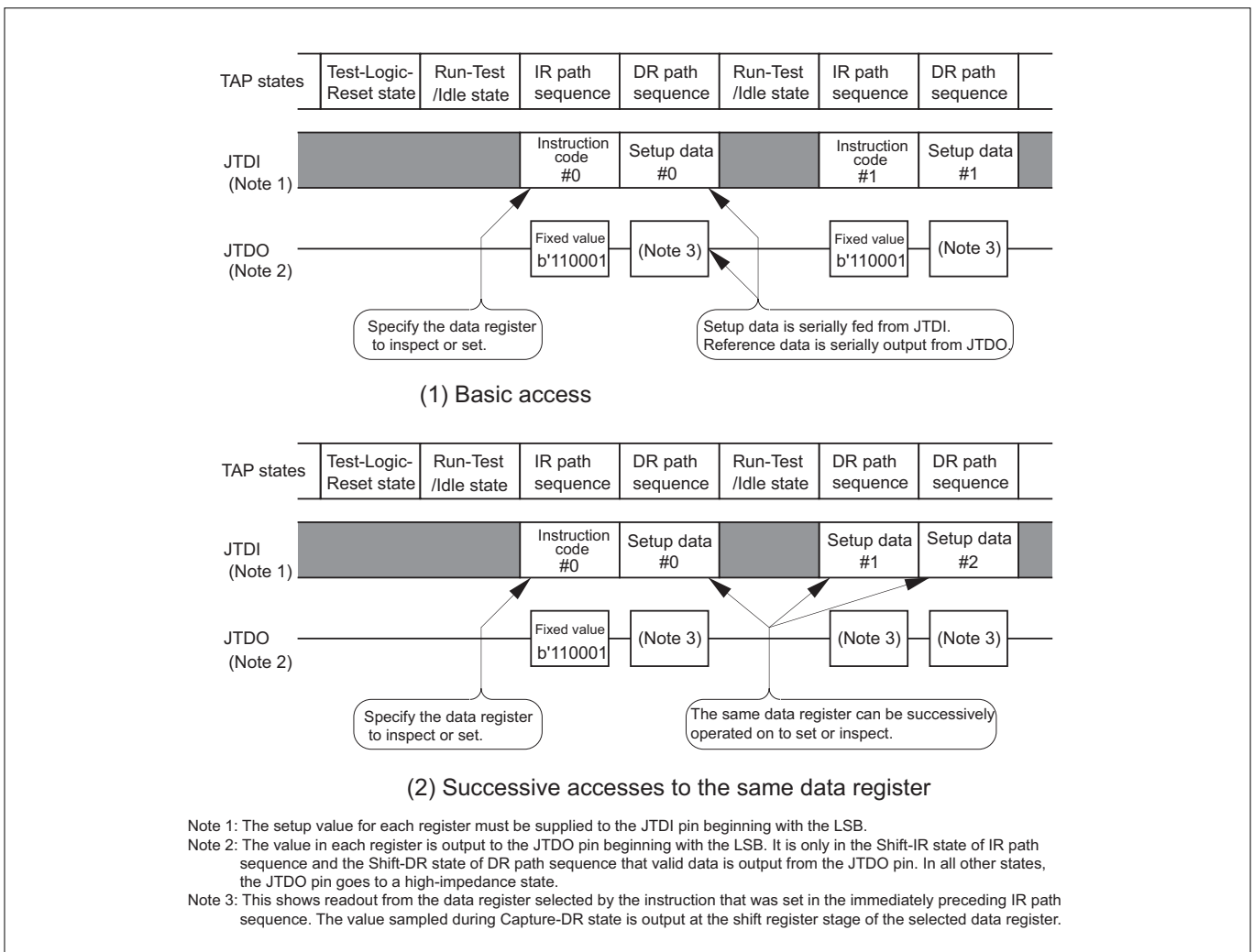


Figure 21.4.4 DR Path Sequence

### 21.4.4 Inspecting and Setting Data Registers

To inspect or set the data register, follow the procedure described below.

- (1) To access the test access port (JTAG) for the first time, apply a test reset (to initialize the test circuit). One of the following two methods may be used to apply a test reset:
  - Pull the JTRST pin "L".
  - Drive the JTMS pin "H" to apply 5 or more JTCK cycles
- (2) Apply JTMS = "L" to enter the Run-Test/Idle state. To continue the idle state, hold JTMS input "L".
- (3) Apply JTMS = "H" to exit the Run-Test/Idle state and perform IR path sequence. In the IR path sequence, specify the data register to inspect or set.
- (4) Proceed to perform DR path sequence. Feed setup data from the JTDI pin into the data register specified in the IR path sequence, and read out reference data from the JTDO pin.
- (5) To proceed to perform IR path or DR path sequence after the DR path sequence is completed, apply JTMS = "H" to return to the Select-DR-Scan state. To wait for the next processing after a series of IR and DR sequence processing is completed, apply JTMS = "L" to enter the Run-Test/Idle state and keep that state.



**Figure 21.4.5 Successive JTAG Access**

## 21.5 Boundary Scan Description Language

The Boundary Scan Description Language (abbreviated BSDL) is described in the supplements to the Standard Test Access Port and Boundary-Scan Architecture of IEEE 1149.1-1990 and IEEE 1149.1a-1993. BSDL is a subset of IEEE 1076-1993 Standard VHSIC Hardware Description Language (VHDL). BSDL allows to precisely describe the functions of conforming components to be tested. For package connection test, this language is used by Automated Test Pattern Generation tools, and for synthesized test logic and verification, this language is used by Electronic Design Automation tools. BSDL provides powerful extended functions usable in internal test generation and necessary to write hardware debug and diagnostics software.

The primary section of BSDL has statements of logical port description, physical pin map, instruction set and boundary register description.

- **Logical port description**

The logical port description assigns meaningful symbol names to each pin on the chip. The logic type of each pin, whether input, output, input/output, buffer or link, that defines the logical direction of signal flow is determined here.

- **Physical pin map**

The physical pin map correlates the chip's logical ports to the physical pins on each package. By using separate names for each map, it is possible to define two or more physical pin maps in one BSDL description.

- **Instruction set statement**

The instruction set statement writes bit patterns to be shifted in into the chip's instruction register. This bit pattern is necessary to place the chip into each test mode defined in standards. Instructions exclusive to the chip can also be written.

- **Boundary register description**

The boundary register description is a list of boundary register cells or shift stages. Each cell is assigned a separate number. The cell with number 0 is located nearest to the test data output (JTDO) pin, and the cell with the largest number is located nearest to the test data input (JTDI) pin. Cells also contain related other information which includes cell type, logical port corresponding to the cell, logical function of the cell, safety value, control cell number, disable value and result value.

Note: • Boundary Scan Description Language (BSDL) can be downloaded from Renesas Technology Website after mass production.

## 21.6 Notes on Board Design when Connecting JTAG

To materialize fast and highly reliable communication with JTAG tools, make sure wiring lengths of JTAG pins are matched during board design.

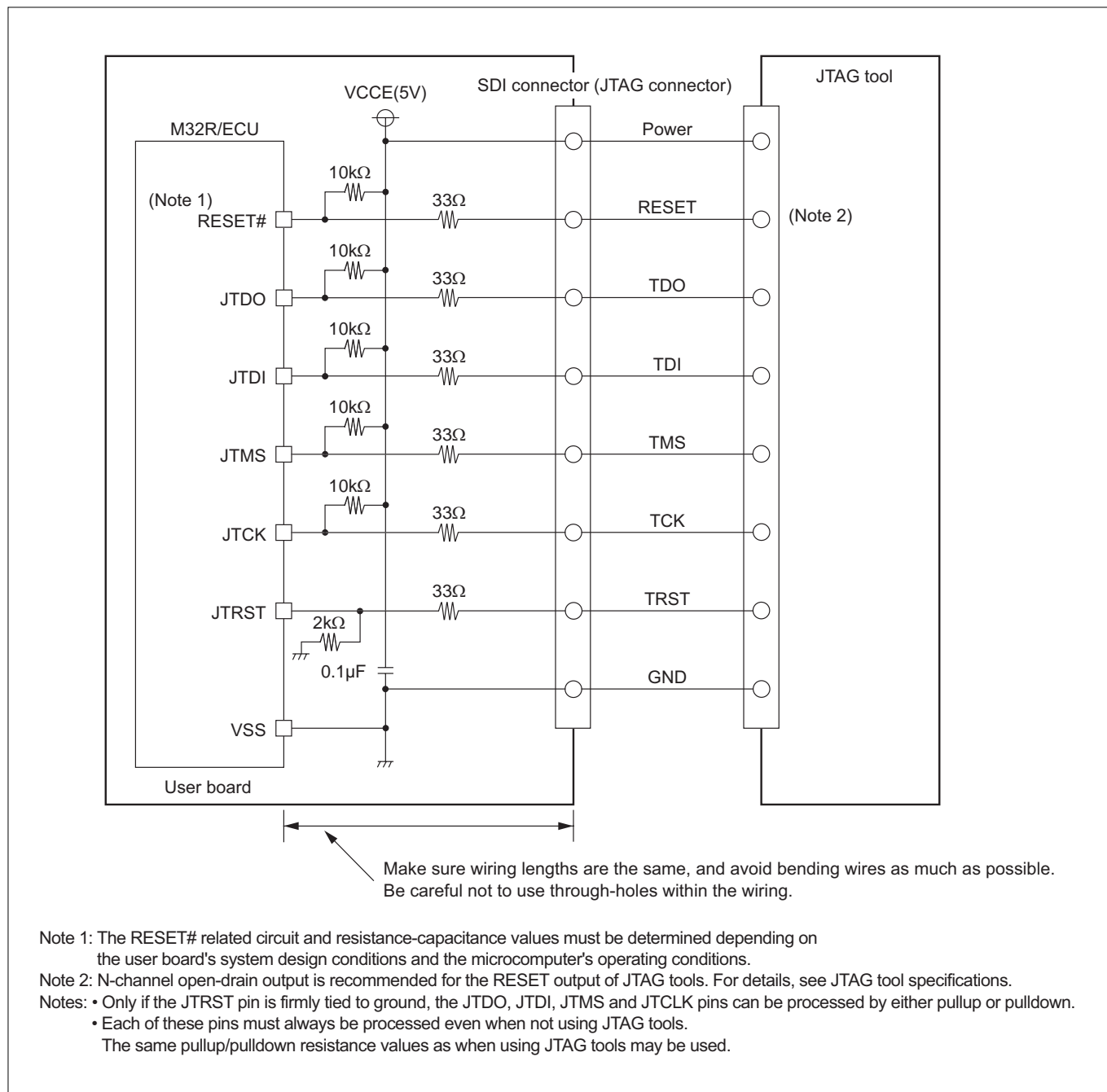


Figure 21.6.1 Notes on Board Design when Connecting JTAG Tools

## 21.7 Processing Pins when Not Using JTAG

The following shows how the pins on the chip should be processed when not using JTAG tools.

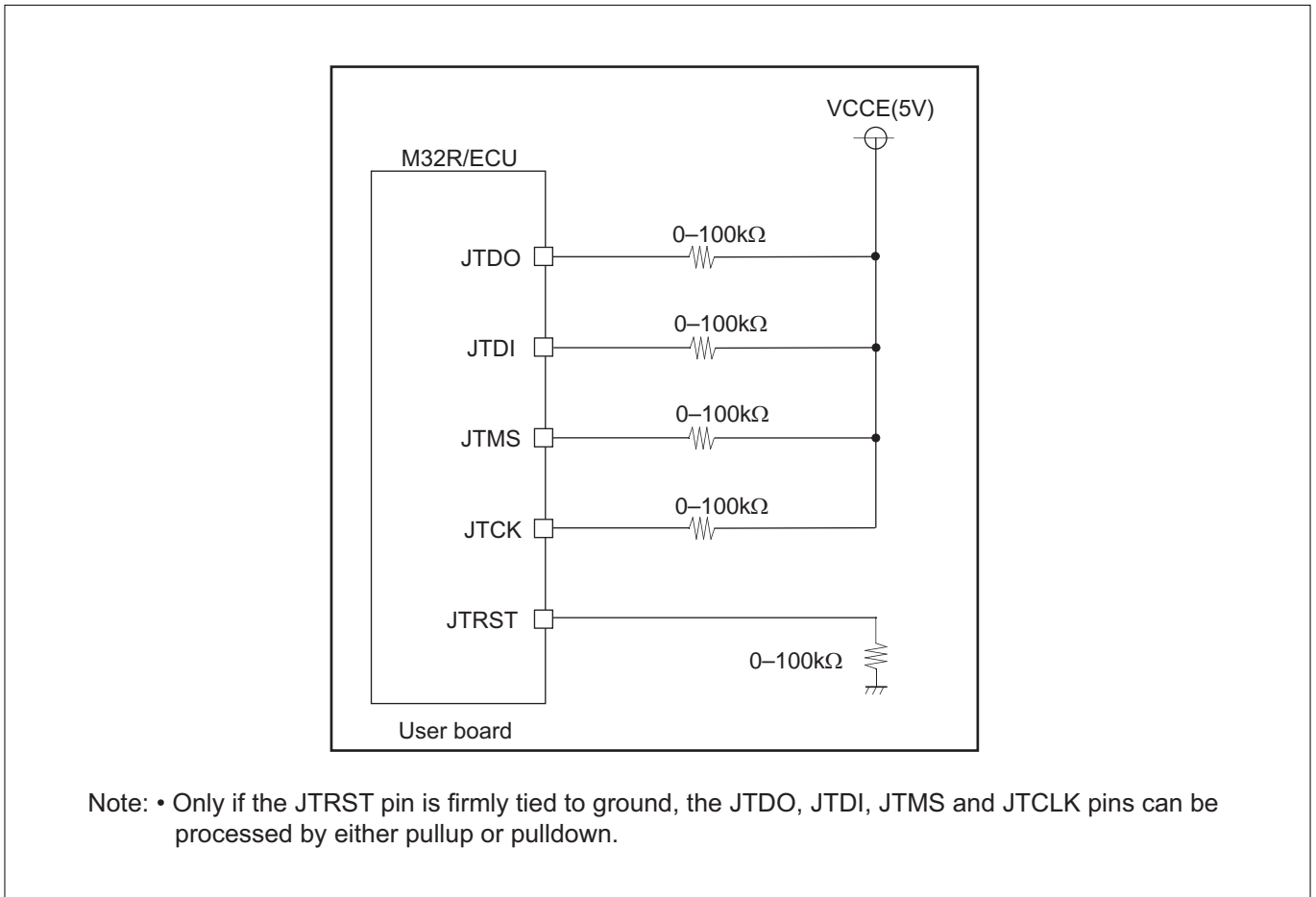


Figure 21.7.1 Processing Pins when Not Using JTAG

This page is blank for reasons of layout.

## **CHAPTER 22**

---

# **POWER SUPPLY CIRCUIT**

- 22.1 Configuration of the Power Supply Circuit
- 22.2 Power-On Sequence
- 22.3 Power-Off Sequence

## 22.1 Configuration of the Power Supply Circuit

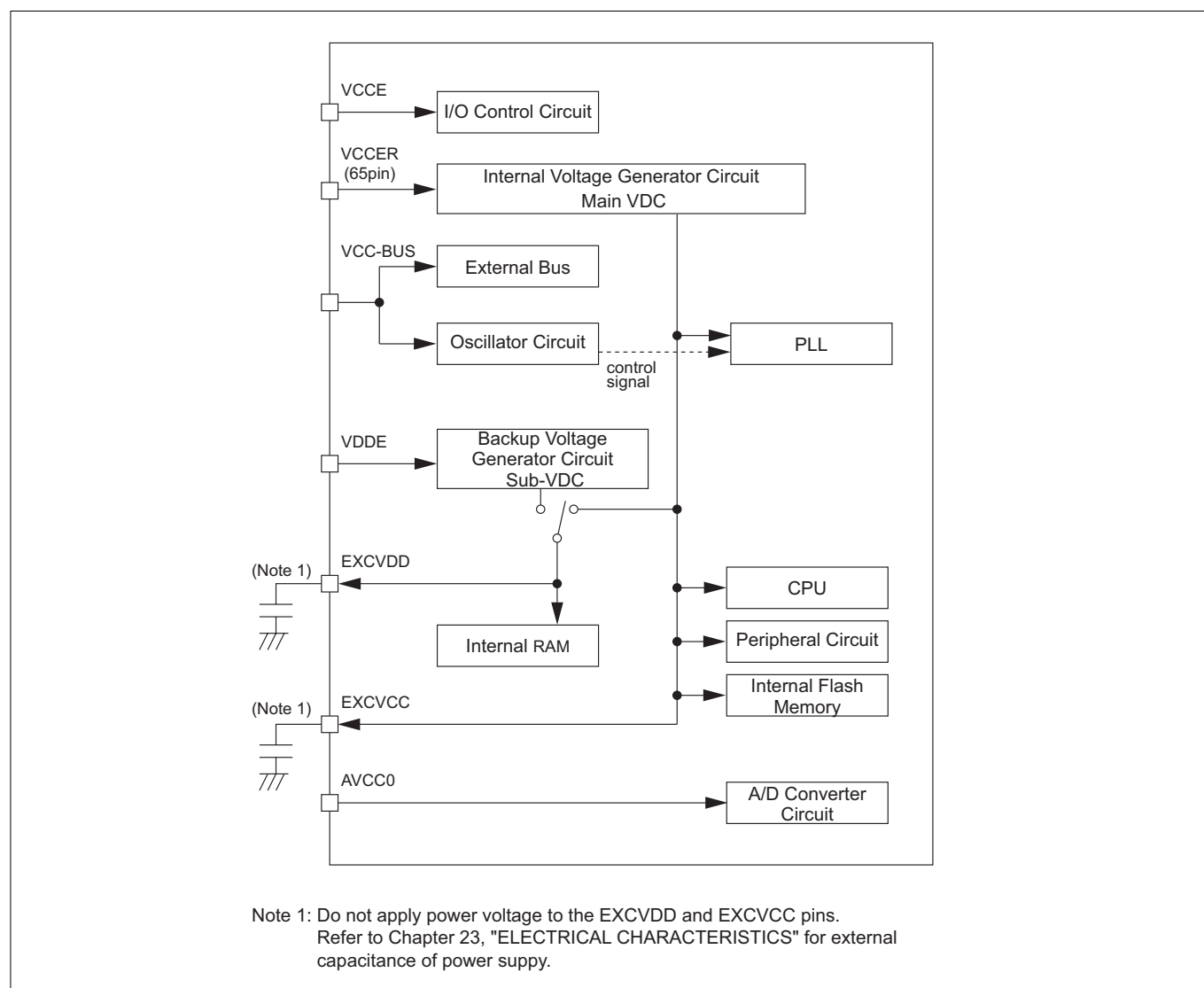
The 32192/32195/32196 operates with a single  $5\text{ V} \pm 0.5\text{ V}$  or  $3.3\text{ V} \pm 0.3\text{ V}$  power supply.

Unless otherwise noted,  $5\text{ V} \pm 0.5\text{ V}$  and  $3.3\text{ V} \pm 0.3\text{ V}$  in this chapter are referred to simply by  $5\text{ V}$  and  $3.3\text{ V}$ , respectively.

**Table 22.1.1 Power Supply Functions**

Power Supply Type	Pin Name	Function
5.0V or 3.3V	VCCE	Main power supply
	AVCC0	Power supply for the A/D converter
	VREF0	Reference voltage for the A/D converter
	VDDE	Power supply for the internal RAM backup
	VCC-BUS	Power supply for the external bus
	EXCVCC	External capacitor connection pin
	EXCVDD	External capacitor connection pin
	VCCER (Note 1)	Power supply for the internal voltage generator circuit (Use 3.3V power supply for the sake of low power consumption)

Note 1: The specification of power supply voltage differs depending on products. For details, see Table 1.1.1 Product List.



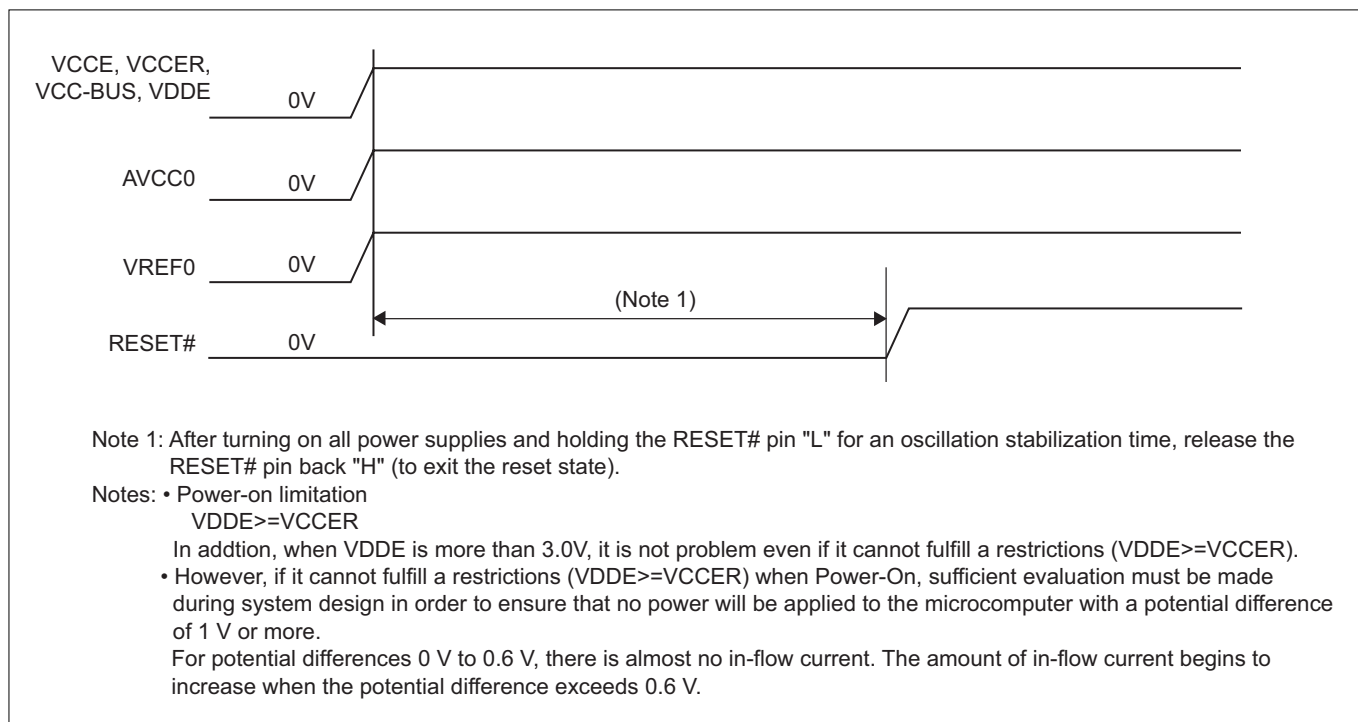
**Figure 22.1.1 Configuration of the Power Supply Circuit (VCCE = 5.0 V or 3.3 V)**



## 22.2 Power-On Sequence

### 22.2.1 Power-On Sequence when Not Using RAM Backup

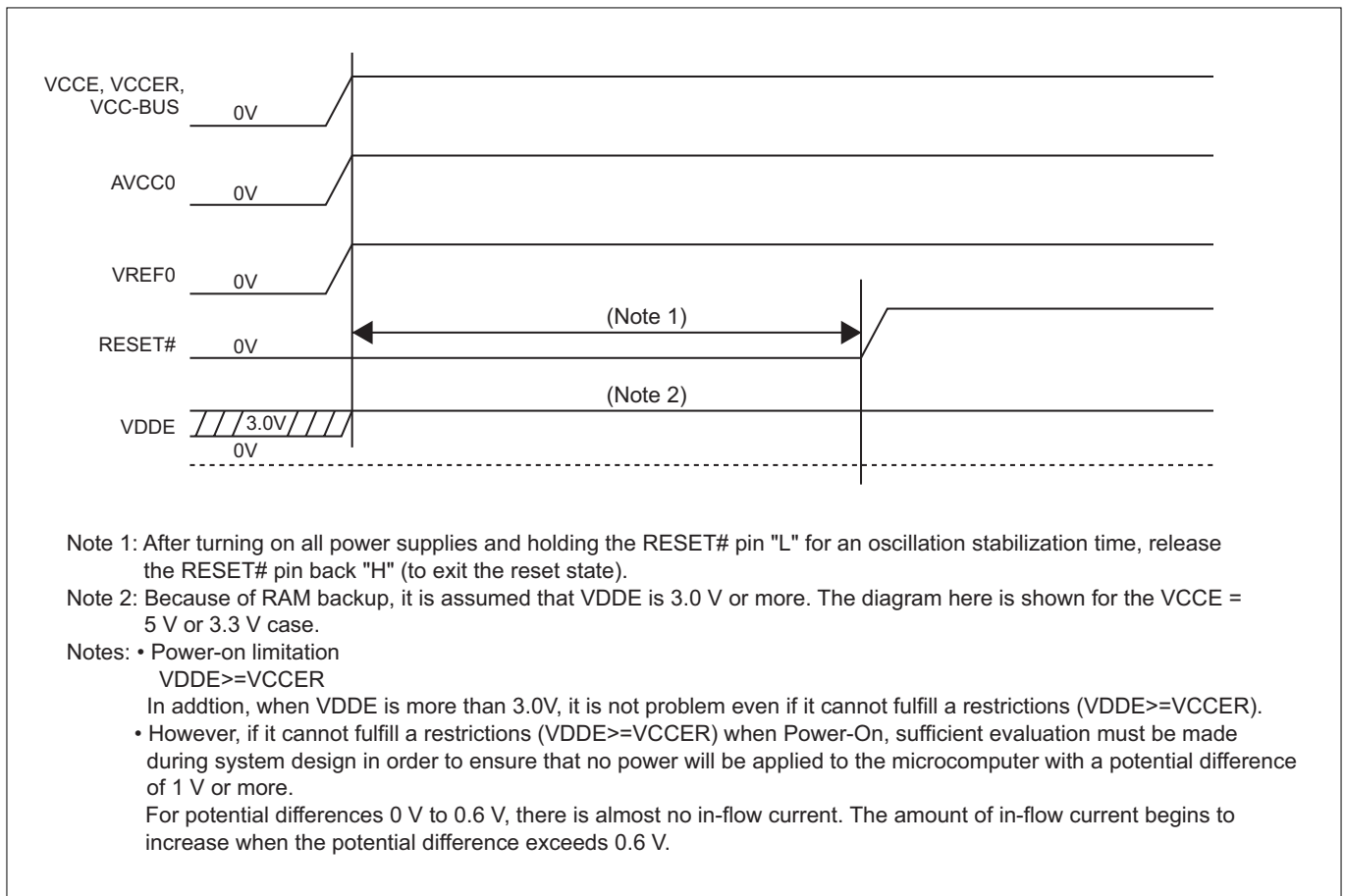
The diagram below shows a turn-on sequence of the power supply (5.0 V or 3.3 V) when not using RAM backup.



**Figure 22.2.1 Power-On Sequence when Not Using RAM Backup**

### 22.2.2 Power-On Sequence when Using RAM Backup

The diagram below shows a turn-on sequence of the power supply (5.0 V or 3.3 V) when using RAM backup.



**Figure 22.2.2 Power-On Sequence when Using RAM Backup**

## 22.3 Power-Off Sequence

### 22.3.1 Power-Off Sequence when Not Using RAM Backup

The diagram below shows a turn-off sequence of the power supply (5.0 V or 3.3 V) when not using RAM backup.

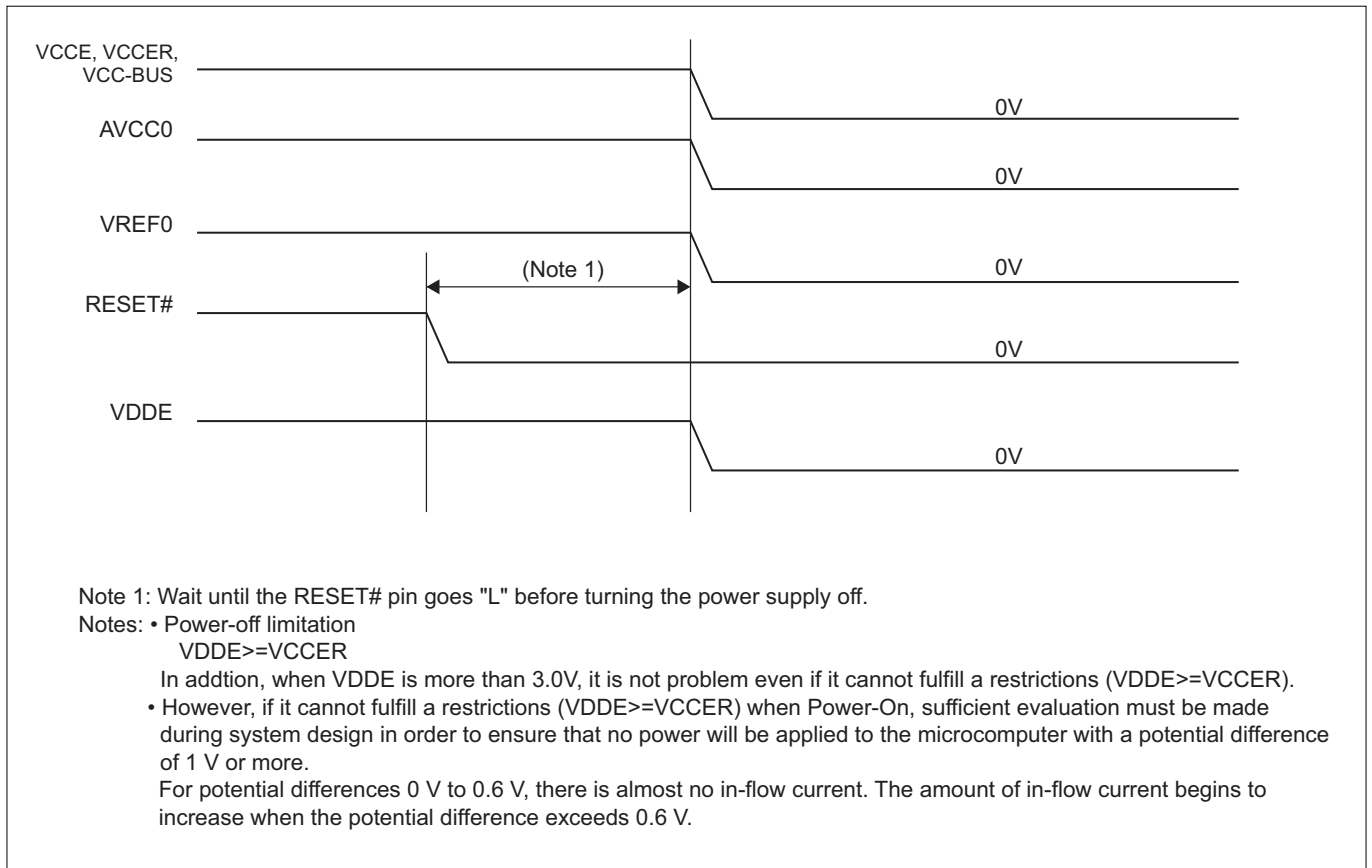


Figure 22.3.1 Power-Off Sequence when Not Using RAM Backup

### 22.3.2 Power-Off Sequence when Using RAM Backup

The diagram below shows a turn-off sequence of the power supply ( $V_{CCE} = V_{DDE} = 5.0\text{ V}$  or  $3.3\text{ V}$ ) when using RAM backup with HREQ function.

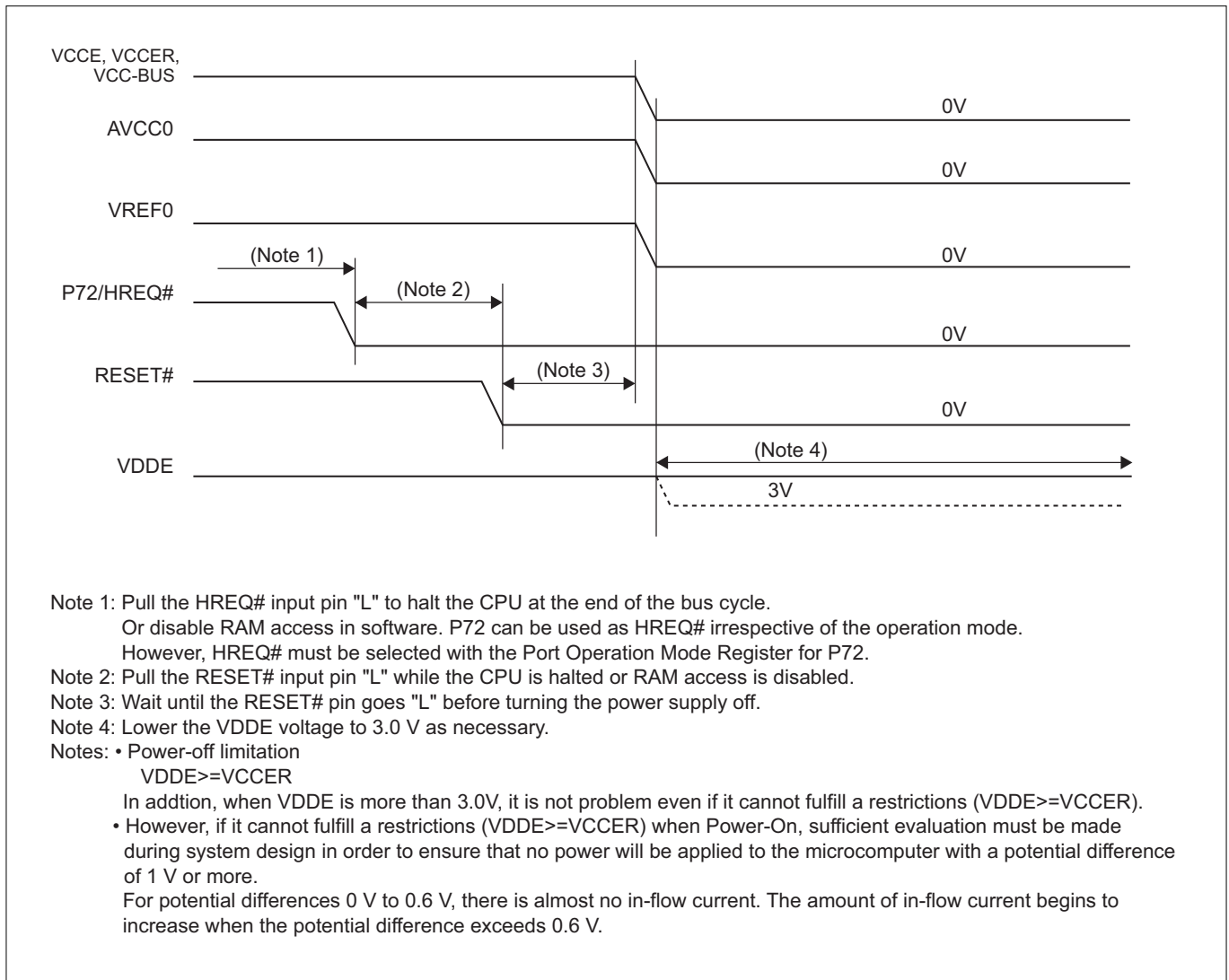


Figure 22.3.2 Power-Off Sequence when Using RAM Backup ( $V_{CCE} = V_{DDE} = 5.0\text{ V}$  or  $3.3\text{ V}$ )

Power-Off Sequence of the power supply (VCCE=5.0V, VDDE=3.3V) when RAM backup is used with operating the HREQ function is shown below.

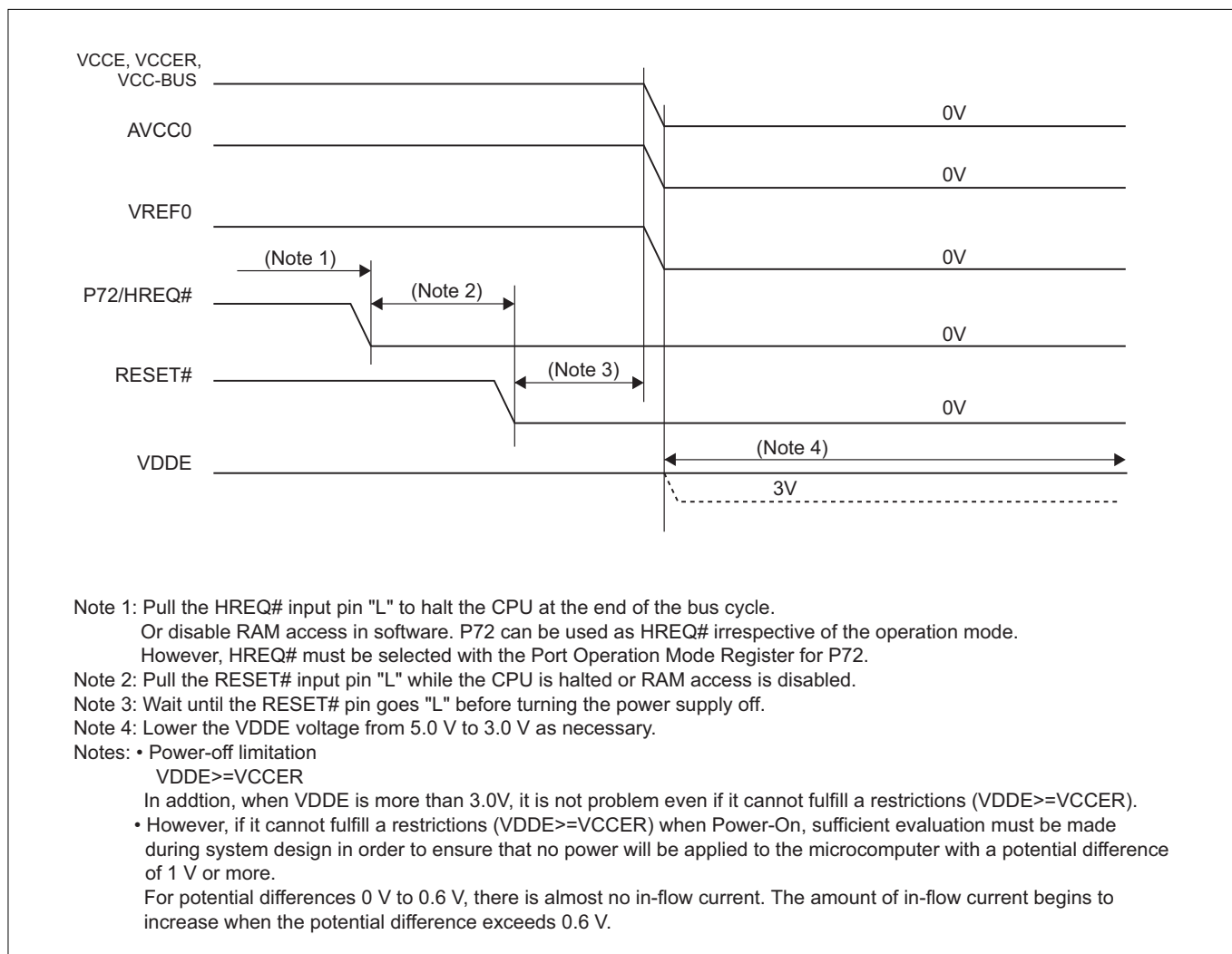
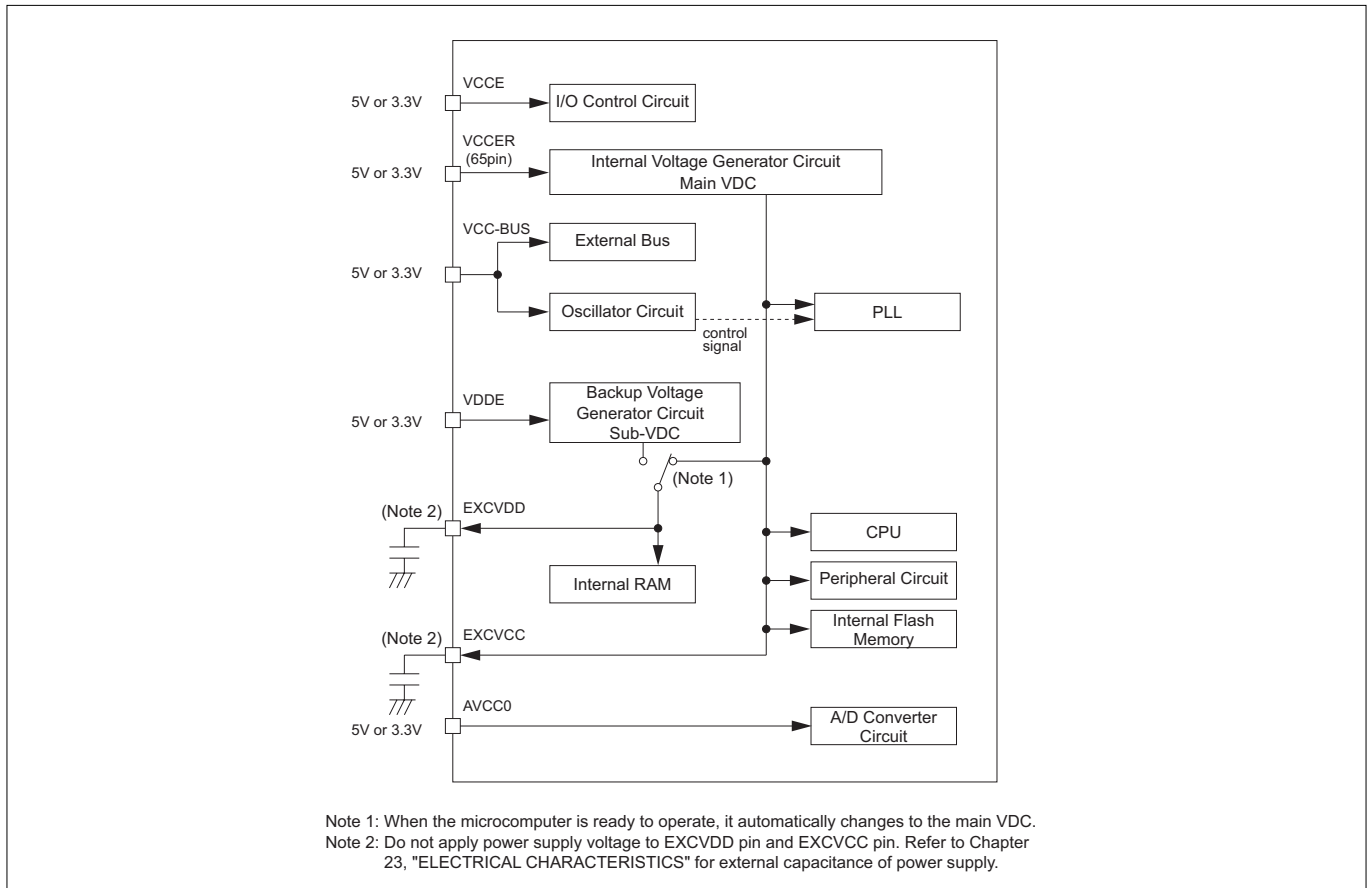
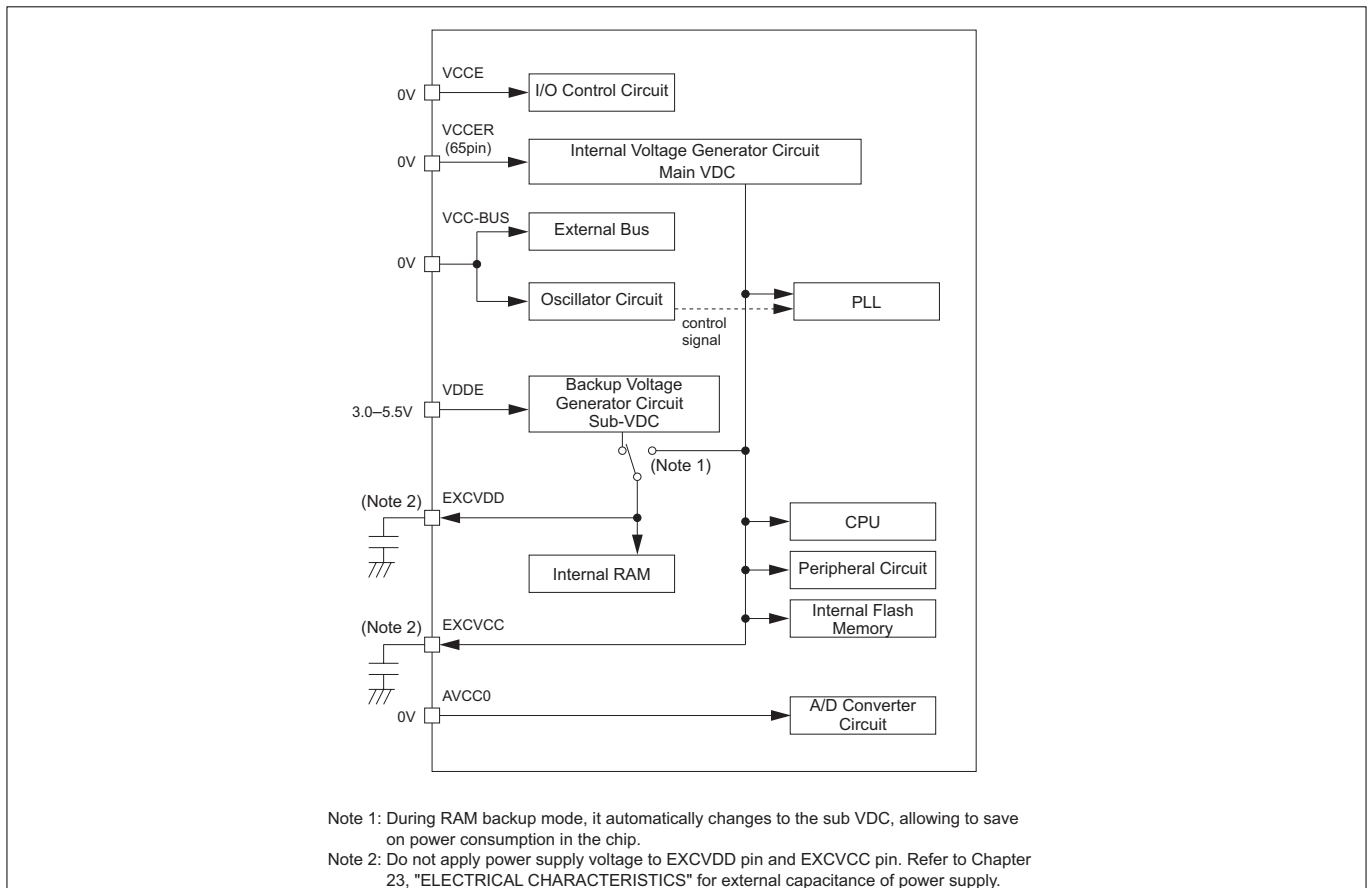


Figure 22.3.3 Power-Off Sequence when Using RAM Backup (VCCE = 5.0V, VDDE = 3.3 V)



**Figure 22.3.4 Microcomputer Ready to Operate State (VCCE = 5.0 V or 3.3 V)**



**Figure 22.3.5 RAM Data Backup State (VCCE = 5.0 V or 3.3 V)**

## CHAPTER 23

---

# ELECTRICAL CHARACTERISTICS

- 23.1 Adapted Table
- 23.2 Absolute Maximum Ratings
- 23.3 Electrical Characteristics  
when  $V_{CC} = 5\text{ V}$ ,  $f(XIN) = 20\text{ MHz}$
- 23.4 Electrical Characteristics  
when  $V_{CC} = 5\text{ V}$ ,  $f(XIN) = 16\text{ MHz}$
- 23.5 Electrical Characteristics  
when  $V_{CC} = 3.3\text{ V}$ ,  $f(XIN) = 20\text{ MHz}$
- 23.6 Electrical Characteristics  
when  $V_{CC} = 3.3\text{ V}$ ,  $f(XIN) = 16\text{ MHz}$
- 23.7 Flash Memory Related Characteristics
- 23.8 External Capacitance for Power Supply
- 23.9 A.C. Characteristics (when  $V_{CC} = 5\text{ V}$ )
- 23.10 A.C. Characteristics (when  $V_{CC} = 3.3\text{ V}$ )

## 23.1 Adapted Table

Conditions				Adapted section number					Note
XIN	VCCE	VCCER	Ambient Temperature (Ta)	Absolute Maximum Ratings	Recommended Operating Conditions, D.C. Characteristics, A/D Conversion Characteristics	Flash Memory Related Characteristics	External Capacitance for Power Supply	A.C. Characteristics	
20MHz	5.0V±0.5V	5.0V±0.5V	-40°C to 85°C	23.2	23.3	23.7	23.8	23.9	(Note 1)
		3.3V±0.3V	-40°C to 85°C	23.2	23.3	23.7	23.8	23.9	(Note 2)
			-40°C to 105°C	23.2	23.3	23.7	23.8	23.9	(Note 2)
	3.3V±0.3V	5.0V±0.5V	-40°C to 85°C	23.2	23.5	23.7	23.8	23.10	(Note 2)
		3.3V±0.3V	-40°C to 105°C	23.2	23.5	23.7	23.8	23.10	(Note 1)
			-40°C to 85°C	23.2	23.5	23.7	23.8	23.10	(Note 1)
16MHz	5.0V±0.5V	5.0V±0.5V	-40°C to 85°C	23.2	23.4	23.7	23.8	23.9	(Note 1)
		3.3V±0.3V	-40°C to 85°C	23.2	23.4	23.7	23.8	23.9	(Note 2)
			-40°C to 105°C	23.2	23.4	23.7	23.8	23.9	(Note 2)
			-40°C to 125°C	23.2	23.4	23.7	23.8	23.9	(Note 2)
	3.3V±0.3V	5.0V±0.5V	-40°C to 85°C	23.2	23.6	23.7	23.8	23.10	(Note 2)
		3.3V±0.3V	-40°C to 85°C	23.2	23.6	23.7	23.8	23.10	(Note 1)
			-40°C to 105°C	23.2	23.6	23.7	23.8	23.10	(Note 1)
			-40°C to 125°C	23.2	23.6	23.7	23.8	23.10	(Note 1)

Note 1: If not specified, VCCE=VCC-BUS=VDDE=VCCER

Note 2: If not specified, VCCE=VCC-BUS=VDDE

## 23.2 Absolute Maximum Ratings

## Absolute Maximum Ratings

Symbol	Parameter	Test Condition	Rated Value	Unit
VCCE	Main Power Supply		-0.3 to 6.5	V
VCCER	Power Supply for the internal voltage generator circuit		-0.3 to 6.5	V
VCC-BUS	Bus Power Supply		-0.3 to 6.5	V
VDDE	RAM Power Supply		-0.3 to 6.5	V
AVCC	Analog Power Supply	VCCE≥AVCC≥VREF	-0.3 to 6.5	V
VREF	Reference Voltage Input	VCCE≥AVCC≥VREF	-0.3 to 6.5	V
VI	XIN		-0.3 to VCC-BUS+0.3	V
	Other (Note 2)		-0.3 to VCCE (VCC-BUS)+0.3	V
VO	XOUT		-0.3 to VCC-BUS+0.3	V
	Other (Note 2)		-0.3 to VCCE (VCC-BUS)+0.3	V
Pd	Power Dissipation	Ta=-40 to 85°C	1200	mW
		Ta=-40 to 105°C	800	mW
		Ta=-40 to 125°C	650	mW
TOPR	Operating Ambient Temperature (Note 1)		-40 to 125	°C
Tstg	Storage Temperature		-65 to 150	°C

Note 1: This does not guarantee that the microcomputer can operate continuously at 85°C-plus. Consult Renesas if the microcomputer is going to be used for 85°C-plus applications.

Note 2: The following ports below operate not with VCCE power supply but with VCC-BUS power supply, so that a regulation value serves as VCC-BUS standard.

P00–P07, P10–P17, P20–P27, P30–P37, P41–P47, P150, P153, P220, P221, P224, P225, XIN, XOUT



### 23.3 Electrical Characteristics when VCCE = 5 V, f(XIN) = 20 MHz

#### 23.3.1 Recommended Operating Conditions (when VCCE = 5 V ± 0.5 V, f(XIN) = 20 MHz)

Recommended Operating Conditions (In case if VCCE, VCCER, VCC-BUS, VDDE, Ta are not specified referenced to "23.1 Adapted Table.")

Symbol	Parameter			Rated Value			Unit		
				MIN	TYP	MAX			
VCCE	Main Power Supply (Note 1)			4.5	5.0	5.5	V		
VCCER	Power Supply for the Internal Voltage Generator Circuit (Note 1)(Note 2)			3.0	3.3	3.6	V		
				4.5	5.0	5.5	V		
VCC-BUS	Bus Power Supply (Note 1)			4.5	5.0	5.5	V		
VDDE	RAM Power Supply (Note 1)			4.5	5.0	5.5	V		
AVCC	Analog Power Supply (Note 1)			4.5	5.0	5.5	V		
VREF	Reference Voltage Input (Note 1)			4.5	5.0	5.5	V		
VIH	Input "H" Voltage (Note 3)	Threshold switching function (multipurpose port function pin)	When CMOS input is selected	Threshold selection : 0.35VCCE	0.45VCCE		VCCE	V	
				Threshold selection : 0.5VCCE	0.6VCCE		VCCE	V	
				Threshold selection : 0.7VCCE	0.8VCCE		VCCE	V	
			When Schmitt input is selected	VT+/VT- : 0.5VCCE/0.35VCCE	0.6VCCE		VCCE	V	
				VT+/VT- : 0.7VCCE/0.35VCCE	0.8VCCE		VCCE	V	
				VT+/VT- : 0.7VCCE/0.5VCCE	0.8VCCE		VCCE	V	
		FP, MOD0, MOD1, JTMS, JTRST, JTCK/ NBDCLK, JTDI/NBDSYNC#, RESET#			0.8VCCE			VCCE	V
		Standard input for the following pins: RTDCLK, RTDRXD, SCLKI0, SCLKI1, SCLKI4, SCLKI5, RXD0–RXD5, TCLK0–TCLK3, TIN0, TIN3, TIN16–TIN26, CRX0, CRX1, NBDD0–NBDD3			0.8VCCE			VCCE	V
		Standard input for the following pins: DB0–B15, WAIT# TIN4–TIN11, TIN30–TIN33			0.43VCCE			VCCE	V
		Standard input for the following pins: SBI#, HREQ#, TIN27			0.6VCCE			VCCE	V
XIN threshold oscillation abort dection (Note 6)			0.65VCC-BUS			VCC-BUS	V		

Symbol	Parameter			Rated Value			Unit	
				MIN	TYP	MAX		
VIL	Input Low Voltage (Note 3)	Threshold switching function (multipurpose port function pin)	When CMOS input is selected	Threshold selection : 0.35VCCE	0		0.25VCCE	V
				Threshold selection : 0.5VCCE	0		0.4VCCE	V
				Threshold selection : 0.7VCCE	0		0.6VCCE	V
			When Schmitt input is selected	VT+/VT- : 0.5VCCE/0.35VCCE	0		0.25VCCE	V
				VT+/VT- : 0.7VCCE/0.35VCCE	0		0.25VCCE	V
				VT+/VT- : 0.7VCCE/0.5VCCE	0		0.4VCCE	V
		FP, MOD0, MOD1, JTMS, JTRST, JTCK/NBDCLK, JTDI/ NBDSYNC#, RESET#			0		0.2VCCE	V
		Standard input for the following pins: RTDCLK, RTDRXD, SCLKI0, SCLKI1, SCLKI4, SCLKI5, RXD0–RXD5, TCLK0–TCLK3, TIN0, TIN3, TIN16–TIN26, CRX0, CRX1, NBDD0–NBDD3			0		0.25VCCE	V
		Standard input for the following pins: DB0–DB15, WAIT# TIN4–TIN11, TIN30–TIN33			0		0.16VCCE	V
		Standard input for the following pins: SBI#, HREQ#, TIN27			0		0.25VCCE	V
XIN threshold oscillation abort dection (Note 6)			0		0.35VCC-BUS	V		
IOH(peak)	"H" State Peak Output Current P0–P22 (Note 4)					-10	mA	
IOH(avg)	"H" State Average Output Current P0–P22 (Note 5)					-5	mA	
IOL(peak)	"L" State Peak Output Current P0–P22 (Note 4)					10	mA	
IOL(avg)	"L" State Average Output Current P0–P22 (Note 5)					5	mA	
CL	Output Load	NBDD0–NBDD3 (output), NBDEVNT#					100	pF
	Capacitance	JTDO					80	pF
		Other than above			15		50	pF
f(XIN)	External Clock Input Frequency			15		20	MHz	

Note 1: Subject to conditions VCCE ≥ AVCC ≥ VREF

Note 2: When Ta = -40°C–85, VCCER = 5V ± 0.5V

Note 3: The ports listed below operate with the VCC-BUS power supply, and not with the VCCE power supply. Therefore, the reference voltage for these ports is the VCC-BUS input voltage.

P00–07, P10–17, P20–27, P30–37, P41–47, P150, P153, P220, P221, P224, P225, XIN, XOUT

Note 4: Make sure the total output current (peak) of ports is

| ports P0 + P1 + P2 | ≤ 80 mA

| ports P3 + P4 + P13 + P15 + P22 | ≤ 80 mA

| ports P6 + P7 + P8 + P9 + P17 | ≤ 80 mA

| ports P10 + P11 + P12 | ≤ 80 mA

Note 5: The average output current is a value averaged during a 100 ms period.

Note 6: Prescribe a voltage level in order XIN oscillation stop detection circuit can judge changing XIN level. For that it is necessary to remain the voltage in VIH/VIL standard more than 5ns.

23.3.2 D.C. Characteristics (when  $V_{CC} = 5\text{ V} \pm 0.5\text{ V}$ ,  $f(XIN) = 20\text{ MHz}$ )

Electrical Characteristics (In case if  $V_{CC}$ ,  $V_{CCER}$ ,  $V_{CC-BUS}$ ,  $V_{DD}$ ,  $T_a$  are not specified referenced to "23.1 Adapted Table.")

Symbol	Parameter	Test Condition	Rated Value			Unit
			MIN	TYP	MAX	
VOH	Output "H" Voltage	$I_{OH} \geq 5\text{mA}$	$V_{CC} + 0.165 \times I_{OH} \text{ (mA)}$		$V_{CC}$	V
VOL	Output "L" Voltage	$I_{OL} \leq 5\text{mA}$	0		$0.15 \times I_{OL} \text{ (mA)}$	V
VDDE	RAM Retention Power Supply Voltage	When operating	4.5		5.5	V
		During backup	3.0		5.5	V
I <sub>IH</sub>	"H" State Input Current	$V_I = V_{CC}$	-5		5	$\mu\text{A}$
I <sub>IL</sub>	"L" State Input Current	$V_I = 0\text{V}$	-5		5	$\mu\text{A}$
ICC	Total Power Supply Current (Note 1)	During reset			90	mA
		When operating		150	210	
IDDE <sub>hold</sub>	RAM Retention	$T_a = 25^\circ\text{C}$		60	800	$\mu\text{A}$
	Power Supply Current (32192)	$T_a = 105^\circ\text{C}$		300	3000	
	RAM Retention	$T_a = 25^\circ\text{C}$		24	320	
	Power Supply Current (32195)	$T_a = 105^\circ\text{C}$		150	1500	
	RAM Retention	$T_a = 25^\circ\text{C}$		24	320	
	Power Supply Current (32196)	$T_a = 105^\circ\text{C}$		150	1500	
VT <sub>+-</sub>	FP, MOD0, MOD1, JTMS, JTRST, JTDI/NBDSYNC#, RESET#		1.0			V
VT <sub>-</sub>	Standard input for the following pins: RTDCLK, RTDRXD, SCLKI0, SCLKI1, SCLKI4, SCLKI5, RXD0–RXD5, TCLK0–TCLK3, TIN0, TIN3, TIN16–TIN26, CRX0, CRX1, NBDD0–NBDD3		1.0			
	Standard input for the following pins: SBI#, HREQ#, TIN27		0.3			
	When threshold switching function is used (VT <sub>+</sub> / VT <sub>-</sub> )	0.7V <sub>CC</sub> /0.35V <sub>CC</sub>	1.0			
	0.7V <sub>CC</sub> /0.5V <sub>CC</sub>	0.3				
	0.5V <sub>CC</sub> /0.35V <sub>CC</sub>	0.3				

Note 1: Total amount of current when single-chip mode

## Electrical Characteristics of Each Power Supply Pin

Symbol	Parameter	Test Condition	Rated Value			Unit
			MIN	TYP	MAX	
ICCE	$V_{CC}$ Power Supply Current When Operating	$f(XIN) = 20.0\text{MHz}$			20	mA
ICCER	$V_{CCER}$ Power Supply Current When Operating	$f(XIN) = 20.0\text{MHz}$			190	mA
IDDE	$V_{DD}$ Power Supply Current When Operating	$f(XIN) = 20.0\text{MHz}$			1	mA
ICC-BUS	$V_{CC-BUS}$ Power Supply Current When Operating	$f(XIN) = 20.0\text{MHz}$			20	mA
I <sub>AVCC</sub>	$V_{AVCC}$ Power Supply Current When Operating	$f(XIN) = 20.0\text{MHz}$			3	mA
I <sub>VREF</sub>	$V_{REF}$ Power Supply Current When Operating	$f(XIN) = 20.0\text{MHz}$			1	mA

## 23.3.3 A/D Conversion Characteristics (when VCCE = 5 V ± 0.5 V, f(XIN) = 20 MHz)

A/D Conversion Characteristics (In case if VCCE,VCCER,VCC-BUS,VDDE,Ta are not specified referred to "23.1 Adapted Table.")

Symbol	Parameter			Test Condition	Rated Value			Unit
					MIN	TYP	MAX	
–	Resolution			VREF=VCCE=AVCC			10	bits
–	Absolute Accuracy (Note 1)	Invalid S&H	Slow mode	Normal speed			±2	LSB
				Double speed			±2	
			Fast mode	Normal speed			±3	
				Double speed			±3	
		Valid normal S&H, invalid synchronous S&H	Slow mode	Normal speed			±2	
				Double speed			±2	
			Fast mode	Normal speed			±3	
				Double speed			±3	
		Valid fast S&H, invalid synchronous S&H	Slow mode	Normal speed			±3	
				Double speed			±3	
			Fast mode	Normal speed			±3	
				Double speed			±8	
		Valid normal S&H, valid synchronous S&H	Slow mode	Normal speed			±3	
				Double speed			±3	
			Fast mode	Normal speed			±3	
				Double speed			±3	
Valid fast S&H and synchronous S&H	Slow mode	Normal speed			±3			
		Double speed			±3			
	Fast mode	Normal speed			±3			
		Double speed			±8			
TCONV	Conversion Time	Invalid S&H or valid normal S&H	Slow mode	Normal speed	14.95			μs
				Double speed	8.65			
			Fast mode	Normal speed	6.55			
				Double speed	4.45			
		Valid fast S&H	Slow mode	Normal speed	9.55			
				Double speed	5.05			
			Fast mode	Normal speed	4.75			
				Double speed	2.65			
IIAN	Analog Input Leakage Current (Note 2)			AVSS ≤ ADiIn ≤ AVCC	-5		5	μA

Note 1: Absolute accuracy refers to the accuracy of output code relative to the analog input including all error sources (including quantization error) in an A/D converter, and is calculated using the equation below.

$$\text{Absolute accuracy} = \text{output code} - (\text{analog input voltage ADiIn} / 1 \text{ LSB})$$

When AVCC = AVREF = 5.12 V, 1 LSB = 5 mV.

Note 2: This refers to the input leakage current on ADiIn while the A/D converter remains idle.

Notes: • S&H stands for Sample and Hold

• It is A/D Conversion Characteristics when in 2BCLK mode and VCCE=VCC-BUS=VDDE=5.12V, VCCER=5.12V or 3.072V.

## 23.4 Electrical Characteristics when VCCE = 5 V, f(XIN) = 16 MHz

### 23.4.1 Recommended Operating Conditions (when VCCE = 5 V ± 0.5 V, f(XIN) = 16 MHz)

Recommended Operating Conditions (In case if VCCE, VCCER, VCC-BUS, VDDE, Ta are not specified referenced to "23.1 Adapted Table.")

Symbol	Parameter			Rated Value			Unit		
				MIN	TYP	MAX			
VCCE	Main Power Supply (Note 1)			4.5	5.0	5.5	V		
VCCER	Power Supply for the Internal Voltage Generator Circuit (Note 1)(Note 2)			3.0	3.3	3.6	V		
				4.5	5.0	5.5	V		
VCC-BUS	Bus Power Supply (Note 1)			4.5	5.0	5.5	V		
VDDE	RAM Power Supply (Note 1)			4.5	5.0	5.5	V		
AVCC	Analog Power Supply (Note 1)			4.5	5.0	5.5	V		
VREF	Reference Voltage Input (Note 1)			4.5	5.0	5.5	V		
VIH	Input "H" Voltage (Note 3)	Threshold switching function (multipurpose port function pin)	When CMOS input is selected	Threshold selection : 0.35VCCE	0.45VCCE		VCCE	V	
				Threshold selection : 0.5VCCE			VCCE	V	
				Threshold selection : 0.7VCCE			VCCE	V	
			When Schmitt input is selected	VT+/VT- : 0.5VCCE/0.35VCCE	0.6VCCE		VCCE	V	
				VT+/VT- : 0.7VCCE/0.35VCCE	0.8VCCE		VCCE	V	
				VT+/VT- : 0.7VCCE/0.5VCCE	0.8VCCE		VCCE	V	
		FP, MOD0, MOD1, JTMS, JTRST, JTCK/NBDCLK, JTDI/NBDSYNC#, RESET#				0.8VCCE		VCCE	V
		Standard input for the following pins: RTDCLK, RTDRXD, SCLKI0, SCLKI1, SCLKI4, SCLKI5, RXD0-RXD5, TCLK0-TCLK3, TIN0, TIN3, TIN16-TIN26, CRX0, CRX1, NBDD0-NBDD3				0.8VCCE		VCCE	V
		Standard input for the following pins: DB0-DB15, WAIT# TIN4-TIN11, TIN30-TIN33				0.43VCCE		VCCE	V
		Standard input for the following pins: SBI#, HREQ#, TIN27				0.6VCCE		VCCE	V
XIN threshold oscillation abort dection (Note 6)				0.65VCC-BUS		VCC-BUS	V		

Symbol	Parameter			Rated Value			Unit	
				MIN	TYP	MAX		
VIL	Input "L" Voltage (Note 3)	Threshold switching function (multipurpose port function pin)	When CMOS input is selected	Threshold selection : 0.35V <sub>CC</sub>	0		0.25V <sub>CC</sub>	V
				Threshold selection : 0.5V <sub>CC</sub>	0		0.4V <sub>CC</sub>	V
				Threshold selection : 0.7V <sub>CC</sub>	0		0.6V <sub>CC</sub>	V
		When Schmitt input is selected	VT+/VT- : 0.5V <sub>CC</sub> /0.35V <sub>CC</sub>	0		0.25V <sub>CC</sub>	V	
			VT+/VT- : 0.7V <sub>CC</sub> /0.35V <sub>CC</sub>	0		0.25V <sub>CC</sub>	V	
			VT+/VT- : 0.7V <sub>CC</sub> /0.5V <sub>CC</sub>	0		0.4V <sub>CC</sub>	V	
		FP, MOD0, MOD1, JTMS, JTRST, JTCK/NBDCLK, JTDI/ NBDSYNC#, RESET#			0		0.2V <sub>CC</sub>	V
		Standard input for the following pins: RTDCLK, RTDRXD, SCLKI0, SCLKI1, SCLKI4, SCLKI5, RXD0–RXD5, TCLK0–TCLK3, TIN0, TIN3, TIN16–TIN26, CRX0, CRX1, NBDD0–NBDD3			0		0.25V <sub>CC</sub>	V
		Standard input for the following pins: DB0–DB15, WAIT# TIN4–TIN11, TIN30–TIN33			0		0.16V <sub>CC</sub>	V
		Standard input for the following pins: SBI#, HREQ#, TIN27			0		0.25V <sub>CC</sub>	V
XIN threshold oscillation abort dection (Note 6)			0		0.35V <sub>CC</sub> -BUS	V		
IOH(peak)	"H" State Peak Output Current P0–P22 (Note 4)					-10	mA	
IOH(avg)	"H" State Average Output Current P0–P22 (Note 5)					-5	mA	
IOL(peak)	"L" State Peak Output Current P0–P22 (Note 4)					10	mA	
IOL(avg)	"L" State Average Output Current P0–P22 (Note 5)					5	mA	
CL	Output Load	NBDD0–NBDD3 (output), NBDEVNT#					100	pF
	Capacitance	JTDO					80	pF
		Other than above			15		50	pF
f(XIN)	External Clock Input Frequency			15		16	MHz	

Note 1: Subject to conditions  $V_{CC} \geq AV_{CC} \geq V_{REF}$

Note 2: When  $T_a = -40^\circ\text{C} \sim 85^\circ\text{C}$ ,  $V_{CCER} = 5\text{ V} \pm 0.5\text{ V}$

Note 3: The ports listed below operate with the VCC-BUS power supply, and not with the VCC power supply. Therefore, the reference voltage for these ports is the VCC-BUS input voltage.

P00–07, P10–17, P20–27, P30–37, P41–47, P150, P153, P220, P221, P224, P225, XIN, XOUT

Note 4: Make sure the total output current (peak) of ports is

| ports P0 + P1 + P2 | ≤ 80 mA

| ports P3 + P4 + P13 + P15 + P22 | ≤ 80 mA

| ports P6 + P7 + P8 + P9 + P17 | ≤ 80 mA

| ports P10 + P11 + P12 | ≤ 80 mA

Note 5: The average output current is a value averaged during a 100 ms period.

Note 6: Prescribe a voltage level in order XIN oscillation stop detection circuit can judge changing XIN level. For that it is necessary to remain the voltage in VIH/VIL standard more than 5ns.

23.4.2 D.C. Characteristics (when  $V_{CC} = 5\text{ V} \pm 0.5\text{ V}$ ,  $f(XIN) = 16\text{ MHz}$ )

Electrical Characteristics (In case if  $V_{CC}$ ,  $V_{CCER}$ ,  $V_{CC-BUS}$ ,  $V_{DD}$ ,  $T_a$  are not specified referenced to "23.1 Adapted Table.")

Symbol	Parameter	Test Condition	Rated Value			Unit
			MIN	TYP	MAX	
VOH	Output "H" Voltage	$I_{OH} \geq 5\text{mA}$	$V_{CC} + 0.165 \times I_{OH} \text{ (mA)}$		$V_{CC}$	V
VOL	Output "L" Voltage	$I_{OL} \leq 5\text{mA}$	0		$0.15 \times I_{OL} \text{ (mA)}$	V
VDDE	RAM Retention Power Supply Voltage	When operating	4.5		5.5	V
		During backup	3.0		5.5	V
IIH	"H" State Input Current	$V_I = V_{CC}$	-5		5	$\mu\text{A}$
IIL	"L" State Input Current	$V_I = 0\text{V}$	-5		5	$\mu\text{A}$
ICC	Total Power Supply Current (Note 1)	During reset			80	mA
		When operating		130	190	
IDDEhold	RAM Retention	$T_a = 25^\circ\text{C}$		60	800	$\mu\text{A}$
	Power Supply Current (32192)	$T_a = 125^\circ\text{C}$		500	5000	
	RAM Retention	$T_a = 25^\circ\text{C}$		24	320	
	Power Supply Current (32195)	$T_a = 125^\circ\text{C}$		200	2000	
	RAM Retention	$T_a = 25^\circ\text{C}$		24	320	
	Power Supply Current (32196)	$T_a = 125^\circ\text{C}$		200	2000	
VT+-	FP, MOD0, MOD1, JTMS, JTRST, JTDI/NBDSYNC#, RESET#		1.0			V
VT-	Standard input for the following pins: RTDCLK, RTDRXD, SCLKI0, SCLKI1, SCLKI4, SCLKI5, RXD0-RXD5, TCLK0-TCLK3, TIN0, TIN3, TIN16-TIN26, CRX0, CRX1, NBDD0-NBDD3		1.0			
	Standard input for the following pins: SBI#, HREQ#, TIN27		0.3			
	When threshold switching function is used (VT+ / VT-)	0.7V <sub>CC</sub> /0.35V <sub>CC</sub>	1.0			
		0.7V <sub>CC</sub> /0.5V <sub>CC</sub>	0.3			
		0.5V <sub>CC</sub> /0.35V <sub>CC</sub>	0.3			

Note 1: Total amount of current when single-chip mode

## Electrical Characteristics of Each Power Supply Pin

Symbol	Parameter	Test Condition	Rated Value			Unit
			MIN	TYP	MAX	
ICCE	$V_{CC}$ Power Supply Current When Operating	$f(XIN) = 16.0\text{MHz}$			20	mA
ICCER	$V_{CCER}$ Power Supply Current When Operating	$f(XIN) = 16.0\text{MHz}$			170	mA
IDDE	$V_{DD}$ Power Supply Current When Operating	$f(XIN) = 16.0\text{MHz}$			1	mA
ICC-BUS	$V_{CC-BUS}$ Power Supply Current When Operating	$f(XIN) = 16.0\text{MHz}$			20	mA
IAVCC	$V_{AVCC}$ Power Supply Current When Operating	$f(XIN) = 16.0\text{MHz}$			3	mA
IVREF	$V_{REF}$ Power Supply Current When Operating	$f(XIN) = 16.0\text{MHz}$			1	mA

## 23.4.3 A/D Conversion Characteristics (when VCCE = 5 V ± 0.5 V, f(XIN) = 16 MHz)

A/D Conversion Characteristics (In case if VCCE,VCCER,VCC-BUS,VDDE, Ta are not specified referred to "23.1 Adapted Table.")

Symbol	Parameter			Test Condition	Rated Value			Unit
					MIN	TYP	MAX	
–	Resolution			VREF=VCCE=AVCC			10	bits
–	Absolute Accuracy (Note 1)	Invalid S&H	Slow mode	Normal speed			±2	LSB
				Double speed			±2	
			Fast mode	Normal speed			±3	
				Double speed			±3	
		Valid normal S&H, invalid synchronous S&H	Slow mode	Normal speed			±2	
				Double speed			±2	
			Fast mode	Normal speed			±3	
				Double speed			±3	
		Valid fast S&H, invalid synchronous S&H	Slow mode	Normal speed			±3	
				Double speed			±3	
			Fast mode	Normal speed			±3	
				Double speed			±8	
		Valid normal S&H, valid synchronous S&H	Slow mode	Normal speed			±3	
				Double speed			±3	
			Fast mode	Normal speed			±3	
				Double speed			±3	
Valid fast S&H and synchronous S&H	Slow mode	Normal speed			±3			
		Double speed			±3			
	Fast mode	Normal speed			±3			
		Double speed			±8			
TCONV	Conversion Time	Invalid S&H or valid normal S&H	Slow mode	Normal speed	18.6875			μs
				Double speed	10.8125			
			Fast mode	Normal speed	8.1875			
				Double speed	5.5625			
		Valid fast S&H	Slow mode	Normal speed	11.9375			
				Double speed	6.3125			
			Fast mode	Normal speed	5.9375			
				Double speed	3.3125			
IIAN	Analog Input Leakage Current (Note 2)			AVSS ≤ ADiIn ≤ AVCC	-5		5	μA

Note 1: Absolute accuracy refers to the accuracy of output code relative to the analog input including all error sources (including quantization error) in an A/D converter, and is calculated using the equation below.

$$\text{Absolute accuracy} = \text{output code} - (\text{analog input voltage ADiIn} / 1 \text{ LSB})$$

When AVCC = AVREF = 5.12 V, 1 LSB = 5 mV.

Note 2: This refers to the input leakage current on ADiIn while the A/D converter remains idle.

Notes: • S&H stands for Sample and Hold

• It is A/D Conversion Characteristics when in 2BCLK mode and VCCE=VCC-BUS=VDDE=5.12V, VCCER=5.12V or 3.072V.



## 23.5 Electrical Characteristics when VCCE = 3.3 V, f(XIN) = 20 MHz

### 23.5.1 Recommended Operating Conditions (when VCCE = 3.3 V ± 0.3 V, f(XIN) = 20 MHz)

Recommended Operating Conditions (In case if VCCE, VCCER, VCC-BUS, VDDE, Ta are not specified referenced to "23.1 Adapted Table.")

Symbol	Parameter			Rated Value			Unit		
				MIN	TYP	MAX			
VCCE	Main Power Supply (Note 1)			3.0	3.3	3.6	V		
VCCER	Power Supply for the Internal Voltage Generator Circuit (Note 1)(Note 2)			3.0	3.3	3.6	V		
				4.5	5.0	5.5	V		
VCC-BUS	Bus Power Supply (Note 1)			3.0	VCCE	3.6	V		
VDDE	RAM Power Supply (Note 1)			3.0	VCCE	3.6	V		
AVCC	Analog Power Supply (Note 1)			3.0	VCCE	3.6	V		
VREF	Reference Voltage Input (Note 1)			3.0	VCCE	3.6	V		
VIH	Input "H" Voltage (Note 3)	Threshold switching function (multipurpose port function pin)	When CMOS input is selected	Threshold selection : 0.35VCCE	0.5VCCE		VCCE	V	
				Threshold selection : 0.5VCCE	0.65VCCE		VCCE	V	
				Threshold selection : 0.7VCCE	0.8VCCE		VCCE	V	
			When Schmitt input is selected	VT+/VT- : 0.5VCCE/0.35VCCE	0.65VCCE		VCCE	V	
				VT+/VT- : 0.7VCCE/0.35VCCE	0.8VCCE		VCCE	V	
				VT+/VT- : 0.7VCCE/0.5VCCE	0.8VCCE		VCCE	V	
		FP, MOD0, MOD1, JTMS, JTRST, JTCK/ NBDCLK, JTDI/NBDSYNC#, RESET#			0.8VCCE			VCCE	V
		Standard input for the following pins: RTDCLK, RTDRXD, SCLKI0, SCLKI1, SCLKI4, SCLKI5, RXD0-RXD5, TCLK0-TCLK3, TIN0, TIN3, TIN16-TIN26, CRX0, CRX1, NBDD0-NBDD3			0.8VCCE			VCCE	V
		Standard input for the following pins: DB0-B15, WAIT# TIN4-TIN11, TIN30-TIN33			0.5VCCE			VCCE	V
		Standard input for the following pins: SBI#, HREQ#, TIN27			0.65VCCE			VCCE	V
XIN threshold oscillation abort dection (Note 6)			0.65VCC-BUS			VCC-BUS	V		

Symbol	Parameter			Rated Value			Unit		
				MIN	TYP	MAX			
VIL	Input "L" Voltage (Note 3)	Threshold switching function (multipurpose port function pin)	When CMOS input is selected	Threshold selection : 0.35VCCE	0		0.2VCCE	V	
				Threshold selection : 0.5VCCE	0		0.35VCCE	V	
				Threshold selection : 0.7VCCE	0		0.5VCCE	V	
			When Schmitt input is selected	VT+/VT- : 0.5VCCE/0.35VCCE		0		0.2VCCE	V
				VT+/VT- : 0.7VCCE/0.35VCCE		0		0.2VCCE	V
				VT+/VT- : 0.7VCCE/0.5VCCE		0		0.35VCCE	V
		FP, MOD0, MOD1, JTMS, JTRST, JTCK/NBDCLK, JTDI/NBDSYNC#, RESET#				0		0.2VCCE	V
		Standard input for the following pins: RTDCLK, RTDRXD, SCLKI0, SCLKI1, SCLKI4, SCLKI5, RXD0–RXD5, TCLK0–TCLK3, TIN0, TIN3, TIN16–TIN26, CRX0, CRX1, NBDD0–NBDD3				0		0.2VCCE	V
		Standard input for the following pins: DB0–DB15, WAIT# TIN4–TIN11, TIN30–TIN33				0		0.2VCCE	V
Standard input for the following pins: SBI#, HREQ#, TIN27				0		0.2VCCE	V		
XIN threshold oscillation abort dection (Note 6)				0		0.35VCC-BUS	V		
IOH(peak)	"H" State Peak Output Current P0–P22 (Note 4)					-10	mA		
IOH(avg)	"H" State Average Output Current P0–P22 (Note 5)					-5	mA		
IOL(peak)	"L" State Peak Output Current P0–P22 (Note 4)					10	mA		
IOL(avg)	"L" State Average Output Current P0–P22 (Note 5)					5	mA		
CL	Output Load	NBDD0–NBDD3 (output), NBDEVNT#				100	pF		
	Capacitance	JTDO				80	pF		
		Other than above		15		50	pF		
f(XIN)	External Clock Input Frequency			15		20	MHz		

Note 1: Subject to conditions VCCE ≥ AVCC ≥ VREF

Note 2: When Ta = -40°C–85, VCCER = 5V ± 0.5V

Note 3: The ports listed below operate with the VCC-BUS power supply, and not with the VCCE power supply. Therefore, the reference voltage for these ports is the VCC-BUS input voltage.

P00–07, P10–17, P20–27, P30–37, P41–47, P150, P153, P220, P221, P224, P225, XIN, XOUT

Note 4: Make sure the total output current (peak) of ports is

| ports P0 + P1 + P2 | ≤ 80 mA

| ports P3 + P4 + P13 + P15 + P22 | ≤ 80 mA

| ports P6 + P7 + P8 + P9 + P17 | ≤ 80 mA

| ports P10 + P11 + P12 | ≤ 80 mA

Note 5: The average output current is a value averaged during a 100 ms period.

Note 6: Prescribe a voltage level in order XIN oscillation stop detection circuit can judge changing XIN level. For that it is necessary to remain the voltage in VIH/VIL standard more than 5ns.

## 23.5.2 D.C. Characteristics (when VCCE = 3.3 V ± 0.3 V, f(XIN) = 20 MHz)

Electrical Characteristics (In case if VCCE, VCCER, VCC-BUS, VDDE, Ta are not specified referenced to "23.1 Adapted Table.")

Symbol	Parameter	Test Condition	Rated Value			Unit
			MIN	TYP	MAX	
VOH	Output "H" Voltage	IOH ≥ 2mA	VCCE+0.5 × IOH (mA)		VCCE	V
VOL	Output "L" Voltage	IOL ≤ 2mA	0		0.225 × IOL (mA)	V
VDDE	RAM Retention Power Supply Voltage	When operating	3.0		3.6	V
		During backup	3.0		3.6	V
IIH	"H" State Input Current	VI = VCCE	-5		5	μA
IIL	"L" State Input Current	VI = 0V	-5		5	μA
ICC	Total Power Supply Current (Note 1)	During reset			90	mA
		When operating		150	210	
IDDEhold	RAM Retention	Ta = 25°C		60	800	μA
	Power Supply Current (32192)	Ta = 105°C		300	3000	
	RAM Retention	Ta = 25°C		24	320	
	Power Supply Current (32195)	Ta = 105°C		150	1500	
	RAM Retention	Ta = 25°C		24	320	
	Power Supply Current (32196)	Ta = 105°C		150	1500	
VT+-	FP, MOD0, MOD1, JTMS, JTRST, JTDI/NBDSYNC#, RESET#		0.65			V
VT-	Standard input for the following pins: RTDCLK, RTDRXD, SCLKI0, SCLKI1, SCLKI4, SCLKI5, RXD0–RXD5, TCLK0–TCLK3, TIN0, TIN3, TIN16–TIN26, CRX0, CRX1, NBDD0–NBDD3		0.5			
	Standard input for the following pins: SBI#, HREQ#, TIN27		0.2			
	When threshold switching function is used (VT+ / VT-)	0.7VCCE/0.35VCCE	0.5			
	0.7VCCE/0.5VCCE	0.2				
	0.5VCCE/0.35VCCE	0.2				

Note 1: Total amount of current when single-chip mode

## Electrical Characteristics of Each Power Supply Pin

Symbol	Parameter	Test Condition	Rated Value			Unit
			MIN	TYP	MAX	
ICCE	VCCE Power Supply Current When Operating	f(XIN)=20.0MHz			14	mA
ICCER	VCCER Power Supply Current When Operating	f(XIN)=20.0MHz			190	mA
IDDE	VDDE Power Supply Current When Operating	f(XIN)=20.0MHz			1	mA
ICC-BUS	VCC-BUS Power Supply Current When Operating	f(XIN)=20.0MHz			14	mA
IAVCC	AVCC Power Supply Current When Operating	f(XIN)=20.0MHz			2	mA
IVREF	VREF Power Supply Current When Operating	f(XIN)=20.0MHz			1	mA

## 23.5.3 A/D Conversion Characteristics (when VCCE = 3.3 V ± 0.3 V, f(XIN) = 20 MHz)

A/D Conversion Characteristics (In case if VCCE,VCCER,VCC-BUS,VDDE,Ta are not specified referred to "23.1 Adapted Table.")

Symbol	Parameter			Test Condition	Rated Value			Unit
					MIN	TYP	MAX	
–	Resolution			VREF=VCCE=AVCC			10	bits
–	Absolute Accuracy (Note 1)	Invalid S&H	Slow mode	Normal speed			±4	LSB
				Double speed			±4	
			Fast mode	Normal speed			±6	
				Double speed			±16	
		Valid normal S&H, invalid synchronous S&H	Slow mode	Normal speed			±4	
				Double speed			±4	
			Fast mode	Normal speed			±6	
				Double speed			±16	
		Valid fast S&H, invalid synchronous S&H	Slow mode	Normal speed			±4	
				Double speed			±16	
			Fast mode	Normal speed			±16	
				Double speed			±48	
		Valid normal S&H, valid synchronous S&H	Slow mode	Normal speed			±4	
				Double speed			±4	
			Fast mode	Normal speed			±6	
				Double speed			±16	
Valid fast S&H and synchronous S&H	Slow mode	Normal speed			±4			
		Double speed			±16			
	Fast mode	Normal speed			±16			
		Double speed			±48			
TCONV	Conversion Time	Invalid S&H or valid normal S&H	Slow mode	Normal speed	14.95			μs
				Double speed	8.65			
			Fast mode	Normal speed	6.55			
				Double speed	4.45			
		Valid fast S&H	Slow mode	Normal speed	9.55			
				Double speed	5.05			
			Fast mode	Normal speed	4.75			
				Double speed	2.65			
IIAN	Analog Input Leakage Current (Note 2)			AVSS ≤ ADiIn ≤ AVCC	-5		5	μA

Note 1: Absolute accuracy refers to the accuracy of output code relative to the analog input including all error sources (including quantization error) in an A/D converter, and is calculated using the equation below.

$$\text{Absolute accuracy} = \text{output code} - (\text{analog input voltage ADiIn} / 1 \text{ LSB})$$

When AVCC = AVREF = 3.072 V, 1 LSB = 3 mV.

Note 2: This refers to the input leakage current on ADiIn while the A/D converter remains idle.

Notes: • S&H stands for Sample and Hold

• It is A/D Conversion Characteristics when in 2BCLK mode and VCCE=VCC-BUS=VDDE=3.072V, VCCER=5.12V or 3.072V.

## 23.6 Electrical Characteristics when VCCE = 3.3 V, f(XIN) = 16 MHz

## 23.6.1 Recommended Operating Conditions (when VCCE = 3.3 V ± 0.3 V, f(XIN) = 16 MHz)

Recommended Operating Conditions (In case if VCCE, VCCER, VCC-BUS, VDDE, Ta are not specified referenced to "23.1 Adapted Table.")

Symbol	Parameter			Rated Value			Unit		
				MIN	TYP	MAX			
VCCE	Main Power Supply (Note 1)			3.0	3.3	3.6	V		
VCCER	Power Supply for the Internal Voltage Generator Circuit (Note 1)(Note 2)			3.0	3.3	3.6	V		
				4.5	5.0	5.5	V		
VCC-BUS	Bus Power Supply (Note 1)			3.0	VCCE	3.6	V		
VDDE	RAM Power Supply (Note 1)			3.0	VCCE	3.6	V		
AVCC	Analog Power Supply (Note 1)			3.0	VCCE	3.6	V		
VREF	Reference Voltage Input (Note 1)			3.0	VCCE	3.6	V		
VIH	Input "H" Voltage (Note 3)	Threshold switching function (multipurpose port function pin)	When CMOS input is selected	Threshold selection : 0.35VCCE	0.5VCCE		VCCE	V	
				Threshold selection : 0.5VCCE	0.65VCCE		VCCE	V	
				Threshold selection : 0.7VCCE	0.8VCCE		VCCE	V	
			When Schmitt input is selected	VT+/VT- : 0.5VCCE/0.35VCCE	0.65VCCE		VCCE	V	
				VT+/VT- : 0.7VCCE/0.35VCCE	0.8VCCE		VCCE	V	
				VT+/VT- : 0.7VCCE/0.5VCCE	0.8VCCE		VCCE	V	
		FP, MOD0, MOD1, JTMS, JTRST, JTCK/NBDCLK, JTDI/NBDSYNC#, RESET#			0.8VCCE			VCCE	V
		Standard input for the following pins: RTDCLK, RTDRXD, SCLKI0, SCLKI1, SCLKI4, SCLKI5, RXD0-RXD5, TCLK0-TCLK3, TIN0, TIN3, TIN16-TIN26, CRX0, CRX1, NBDD0-NBDD3			0.8VCCE			VCCE	V
		Standard input for the following pins: DB0-B15, WAIT# TIN4-TIN11, TIN30-TIN33			0.5VCCE			VCCE	V
Standard input for the following pins: SBI#, HREQ#, TIN27			0.65VCCE			VCCE	V		
XIN threshold oscillation abort dection (Note 6)			0.65VCC-BUS			VCC-BUS	V		

Symbol	Parameter			Rated Value			Unit	
				MIN	TYP	MAX		
VIL	Input "L" Voltage (Note 3)	Threshold switching function (multipurpose port function pin)	When CMOS input is selected	Threshold selection : 0.35VCCE	0		0.2VCCE	V
				Threshold selection : 0.5VCCE	0		0.35VCCE	V
				Threshold selection : 0.7VCCE	0		0.5VCCE	V
			When Schmitt input is selected	VT+/VT- : 0.5VCCE/0.35VCCE	0		0.2VCCE	V
				VT+/VT- : 0.7VCCE/0.35VCCE	0		0.2VCCE	V
				VT+/VT- : 0.7VCCE/0.5VCCE	0		0.35VCCE	V
		FP, MOD0, MOD1, JTMS, JTRST, JTCK/NBDCLK, JTDI/NBDSYNC#, RESET#			0		0.2VCCE	V
		Standard input for the following pins: RTDCLK, RTDRXD, SCLKI0, SCLKI1, SCLKI4, SCLKI5, RXD0–RXD5, TCLK0–TCLK3, TIN0, TIN3, TIN16–TIN26, CRX0, CRX1, NBDD0–NBDD3			0		0.2VCCE	V
		Standard input for the following pins: DB0–DB15, WAIT# TIN4–TIN11, TIN30–TIN33			0		0.2VCCE	V
		Standard input for the following pins: SBI#, HREQ#, TIN27			0		0.2VCCE	V
XIN threshold oscillation abort dection (Note 6)			0		0.35VCC-BUS	V		
IOH(peak)	"H" State Peak Output Current P0–P22 (Note 4)					-10	mA	
IOH(avg)	"H" State Average Output Current P0–P22 (Note 5)					-5	mA	
IOL(peak)	"L" State Peak Output Current P0–P22 (Note 4)					10	mA	
IOL(avg)	"L" State Average Output Current P0–P22 (Note 5)					5	mA	
CL	Output Load	NBDD0–NBDD3 (output), NBDEVNT#					100	pF
	Capacitance	JTDO					80	pF
		Other than above			15		50	pF
f(XIN)	External Clock Input Frequency			15		16	MHz	

Note 1: Subject to conditions VCCE ≥ AVCC ≥ VREF

Note 2: When Ta = -40°C–85, VCCER = 5V ± 0.5V

Note 3: The ports listed below operate with the VCC-BUS power supply, and not with the VCCE power supply. Therefore, the reference voltage for these ports is the VCC-BUS input voltage.

P00–07, P10–17, P20–27, P30–37, P41–47, P150, P153, P220, P221, P224, P225, XIN, XOUT

Note 4: Make sure the total output current (peak) of ports is

| ports P0 + P1 + P2 | ≤ 80 mA

| ports P3 + P4 + P13 + P15 + P22 | ≤ 80 mA

| ports P6 + P7 + P8 + P9 + P17 | ≤ 80 mA

| ports P10 + P11 + P12 | ≤ 80 mA

Note 5: The average output current is a value averaged during a 100 ms period.

Note 6: Prescribe a voltage level in order XIN oscillation stop detection circuit can judge changing XIN level. For that it is necessary to remain the voltage in VIH/VIL standard more than 5ns.

## 23.6.2 D.C. Characteristics (when VCCE = 3.3 V ± 0.3 V, f(XIN) = 16 MHz)

Electrical Characteristics (In case if VCCE, VCCER, VCC-BUS, VDDE, Ta are not specified referenced to "23.1 Adapted Table.")

Symbol	Parameter	Test Condition	Rated Value			Unit
			MIN	TYP	MAX	
VOH	Output "H" Voltage	IOH ≥ 2mA	VCCE+0.5 × IOH (mA)		VCCE	V
VOL	Output "L" Voltage	IOL ≤ 2mA	0		0.225 × IOL (mA)	V
VDDE	RAM Retention Power Supply Voltage	When operating	3.0		3.6	V
		During backup	3.0		3.6	V
I <sub>IH</sub>	"H" State Input Current	V <sub>I</sub> = VCCE	-5		5	μA
I <sub>IL</sub>	"L" State Input Current	V <sub>I</sub> = 0V	-5		5	μA
ICC	Total Power Supply Current (Note 1)	During reset			80	mA
		When operating		130	190	
IDDEhold	RAM Retention	Ta = 25°C		60	800	μA
	Power Supply Current (32192)	Ta = 125°C		500	5000	
	RAM Retention	Ta = 25°C		24	320	
	Power Supply Current (32195)	Ta = 125°C		200	2000	
	RAM Retention	Ta = 25°C		24	320	
	Power Supply Current (32196)	Ta = 125°C		200	2000	
VT+-	FP, MOD0, MOD1, JTMS, JTRST, JTDI/NBDSYNC#, RESET#		0.65			V
VT-	Standard input for the following pins: RTDCLK, RTDRXD, SCLKI0, SCLKI1, SCLKI4, SCLKI5, RXD0-RXD5, TCLK0-TCLK3, TIN0, TIN3, TIN16-TIN26, CRX0, CRX1, NBDD0-NBDD3		0.5			
	Standard input for the following pins: SBI#, HREQ#, TIN27		0.2			
	When threshold	0.7VCCE/0.35VCCE	0.5			
switching function	0.7VCCE/0.5VCCE	0.2				
is used (VT+ / VT-)	0.5VCCE/0.35VCCE	0.2				

Note 1: Total amount of current when single-chip mode

## Electrical Characteristics of Each Power Supply Pin

Symbol	Parameter	Test Condition	Rated Value			Unit
			MIN	TYP	MAX	
ICCE	VCCE Power Supply Current When Operating	f(XIN)=16.0MHz			14	mA
ICCER	VCCER Power Supply Current When Operating	f(XIN)=16.0MHz			170	mA
IDDE	VDDE Power Supply Current When Operating	f(XIN)=16.0MHz			1	mA
ICC-BUS	VCC-BUS Power Supply Current When Operating	f(XIN)=16.0MHz			14	mA
I <sub>AVCC</sub>	AVCC Power Supply Current When Operating	f(XIN)=16.0MHz			2	mA
I <sub>VREF</sub>	VREF Power Supply Current When Operating	f(XIN)=16.0MHz			1	mA

## 23.6.3 A/D Conversion Characteristics (when VCCE = 3.3 V ± 0.3 V, f(XIN) = 8 MHz)

A/D Conversion Characteristics (In case if VCCE,VCCER,VCC-BUS,VDDE,Ta are not specified referred to "23.1 Adapted Table.")

Symbol	Parameter			Test Condition	Rated Value			Unit
					MIN	TYP	MAX	
–	Resolution			VREF=VCCE=AVCC			10	bits
–	Absolute Accuracy (Note 1)	Invalid S&H	Slow mode	Normal speed			±4	LSB
				Double speed			±4	
			Fast mode	Normal speed			±6	
				Double speed			±16	
		Valid normal S&H, invalid synchronous S&H	Slow mode	Normal speed			±4	
				Double speed			±4	
			Fast mode	Normal speed			±6	
				Double speed			±16	
		Valid fast S&H, invalid synchronous S&H	Slow mode	Normal speed			±4	
				Double speed			±16	
			Fast mode	Normal speed			±16	
				Double speed			±48	
		Valid normal S&H, valid synchronous S&H	Slow mode	Normal speed			±4	
				Double speed			±4	
			Fast mode	Normal speed			±6	
				Double speed			±16	
Valid fast S&H and synchronous S&H	Slow mode	Normal speed			±4			
		Double speed			±16			
	Fast mode	Normal speed			±16			
		Double speed			±48			
TCONV	Conversion Time	Invalid S&H or valid normal S&H	Slow mode	Normal speed	18.6875			μs
				Double speed	10.8125			
			Fast mode	Normal speed	8.1875			
				Double speed	5.5625			
		Valid fast S&H	Slow mode	Normal speed	11.9375			
				Double speed	6.3125			
			Fast mode	Normal speed	5.9375			
				Double speed	3.3125			
IIAN	Analog Input Leakage Current (Note 2)			AVSS ≤ ADiIn ≤ AVCC	-5		5	μA

Note 1: Absolute accuracy refers to the accuracy of output code relative to the analog input including all error sources (including quantization error) in an A/D converter, and is calculated using the equation below.

$$\text{Absolute accuracy} = \text{output code} - (\text{analog input voltage ADiIn} / 1 \text{ LSB})$$

When AVCC = AVREF = 3.072 V, 1 LSB = 3 mV.

Note 2: This refers to the input leakage current on ADiIn while the A/D converter remains idle.

Notes: • S&H stands for Sample and Hold

• It is A/D Conversion Characteristics when in 2BCLK mode and VCCE=VCC-BUS=VDDE=3.072V, VCCER=5.12V or 3.072V.



## 23.7 Flash Memory Related Characteristics

Symbol	Parameter		Test Condition	Rated Value			Unit
				MIN	TYP	MAX	
Topr	for Flash rewriting		M3219xF8VFP, M32195F4VFP	-40		125	°C
			M3219xF8UFP, M32195F4UFP	-40		105	
			M3219xF8TFP, M32195F4TFP	-40		85	
cycle	Number of times for Flash rewriting(Note1)	Standard goods		100 (Note 2)			times

Note 1: Definition of the number of times for Flash rewriting

The number of times for Flash rewriting is the number of times for erase for each blocks. When the number of times is 100, it can be erase 100 times for each blocks. However, for ine erase it can not be written in the same adress two or more times(forbiddance of overwriting).

Note 2: It is the minimum number of times which guarantees all the characteristics after program/erase (guarantee is the range from "1" to "minimum" value.

**(1)Standard goods (The number of times for Flash rewriting is 100)**

Symbol	Parameter		Test Condition		Rated Value			Unit
					MIN	TYP	MAX	
tPRG	Program time (Note 1)		4 KByte block	till 100 times		200	1600	μs
			Other than 4 KByte block	till 100 times		100	800	μs
TBERS	Block erase time		4 KByte block	till 100 times		0.3	6	s
			8 KByte block	till 100 times		0.3	6	s
			16 KByte block	till 100 times		0.5	6	s
			32 KByte block	till 100 times		0.7	6	s
			64 KByte block	till 100 times		1.2	6	s

Note 1: Writing time for every 4 half word.

## 23.8 External Capacitance for Power Supply

Symbol	Parameter		Rated Value			Unit
			MIN	TYP	MAX	
EXCVCC	External capacity connestion pins		1		10	μF
EXCVDD	External capacity connestion pins for inside internal Ram power supply		1		10	μF

### 23.9 A.C. Characteristics (when VCCE = 5 V)

- The timing conditions are referenced to VCCE, VCCER, VCC-BUS, VDDE = 5 V ± 0.5 V, Ta = -40°C to 125°C unless otherwise noted.
- The rated values below are guaranteed for the case where the output load capacitance of the measured pins are 15 pF to 50 pF (guaranteed value during centralized capacitance for JTAG related values is 80 pF and for NBD related is 100 pF).
- The terms W, C, S, R and ID in the rated values shown below have the following meaning. For details about CS Area Wait Control Register, see Section 18.2.1, "CS Area Wait Control Registers."
  - W: Number of wait states (selected by the CS Area Wait Control Register WAIT bit)
  - C: "1" when the CS Area Wait Control Register CWAIT bit = 1, or "0" when CWAIT bit = 0
  - S: "1" when the CS Area Wait Control Register SWAIT bit = 1, or "0" when SWAIT bit = 0
  - R: "1" when the CS Area Wait Control Register RECOV bit = 1, or "0" when RECOV bit = 0
  - ID: Number of idle cycles inserted at the end of the bus cycle. Idle cycles may be inserted as specified by the CS Area Wait Control Register IDLE bit, or inserted by default when a write operation is executed immediately after a read (ID = 0 or 1).
- Characteristics of synchronous timing to the external bus clock are values only relative to CLKOUT (none relative to BCLK).
- The CLKOUT/WR# functions are assigned to two separate pins, P70/CLKOUT/WR#/BCLK pins (Pin No.78) and P150/TIN0/CLKOUT/WR# pins (Pin No.133). Unless otherwise noted, characteristics for CLKOUT pin/WR# pin are values of Pin No.133.
- The output drive capability is a value under the following conditions. For output drive capability setting, see Section 8.5, "Port Output Drive Capability Setting Function."
  - CLKOUT pin/WR# pin (Pin No.133): high drive power selected
  - The rest of the output pins: low drive power (the value upon exiting reset) selected

#### (1) Output Switching Characteristics Measurement Circuit

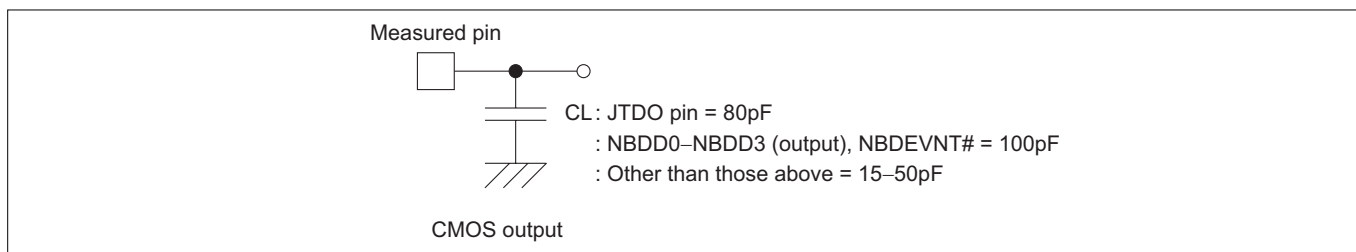


Figure 23.9.1 Output Switching Characteristics Measurement Circuit

#### (2) Input and Output Transition Time

	Symbol	Parameter	Rated Value		Unit	See Fig	
			MIN	MAX			
Timing requirements	tr (INPUT)	High-going TransitionTime of Input	NBDCLK, NBDD0-NBDD3 pins (input),		8	ns	[115]
			NBDSYNC# pin				
			JTCK, JTDI, JTMS		10	ns	
			JTRST pin		2	ms	
	tf (INPUT)	Low-ging Transition Time of Input	NBDCLK, NBDD0-NBDD3 pins (input),		8	ns	[116]
			NBDSYNC# pin				
JTCK, JTDI, JTMS				10	ns		
		JTRST pin		2	ms		

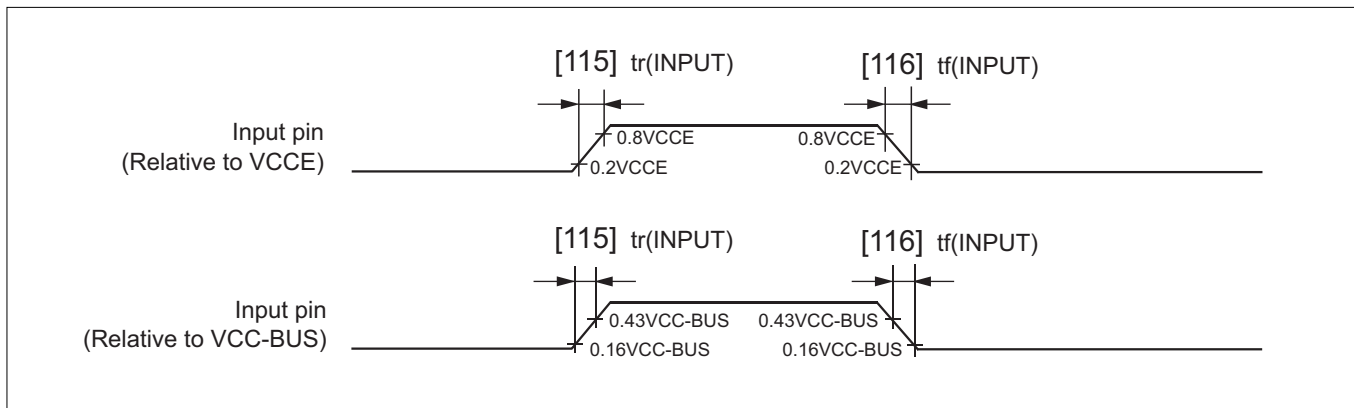


Figure 23.9.2 Input/Output Transition Time

### (3) Clock and Reset Timing

	Symbol	Parameter	Rated Value		Unit	See Fig
			MIN	MAX		
Timing requirements	tc(XIN)	Clock Input Cycle Time	50	66.7	ns	[119]
	tw(XINH)	External Clock Input "H" Pulse Width	20		ns	[120]
	tw(XINL)	External Clock Input "L" Pulse Width	20		ns	[121]
	tr(XINH)	External Clock Input High-going Time		5	ns	[122]
	tr(XINL)	External Clock Input Low-going Time		5	ns	[123]
	tw(RESET)	Reset Input "L" Pulse Width	300		ns	[124]

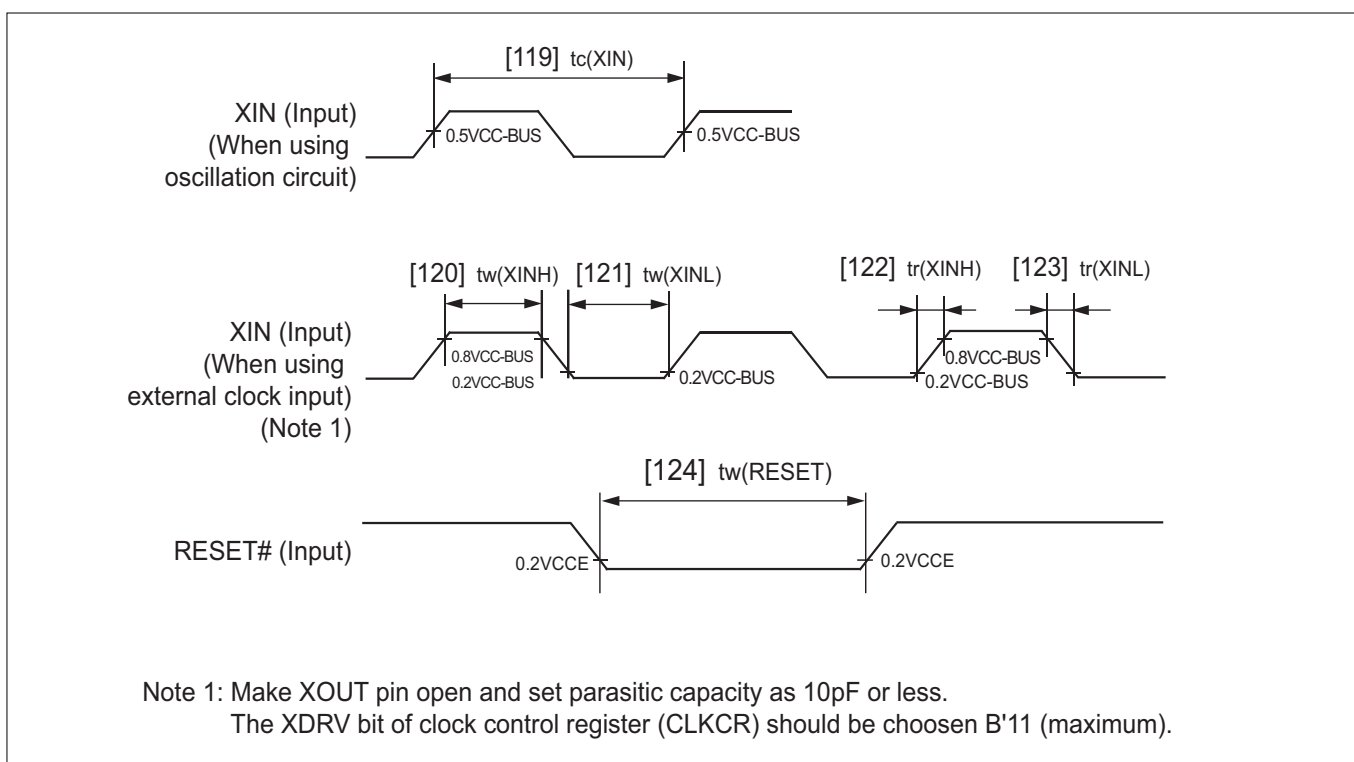
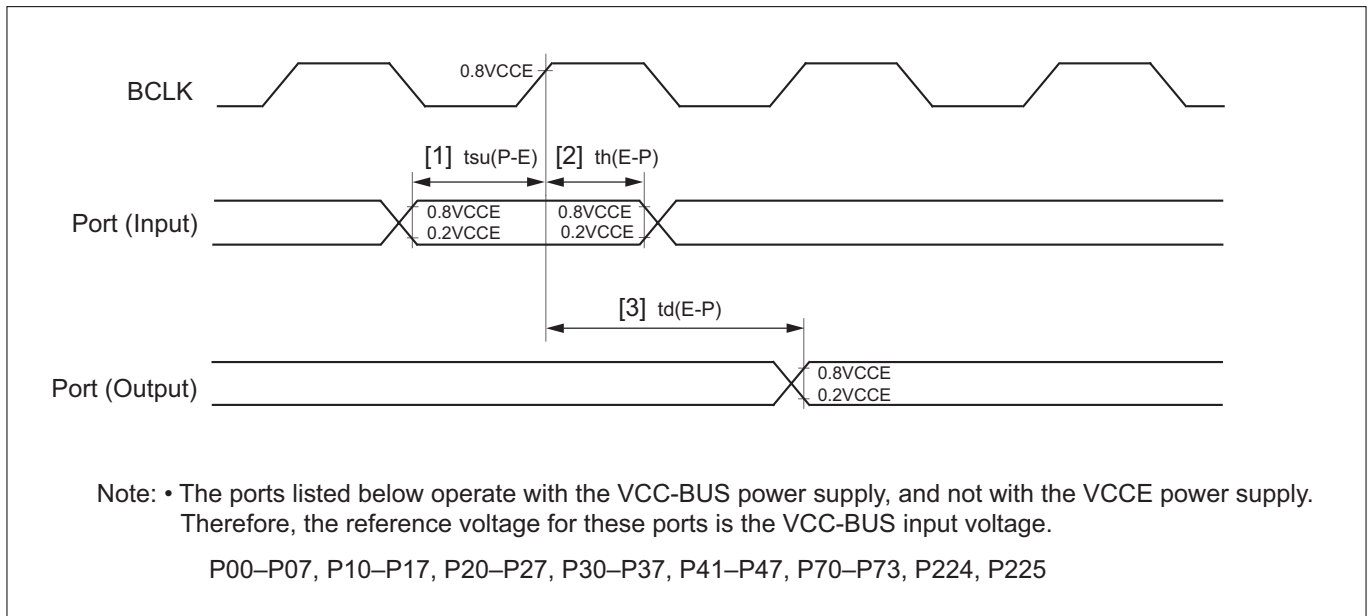


Figure 23.9.3 Clock and Reset Timing

#### (4) Input/output ports

	Symbol	Parameter	Rated Value		Unit	See Fig.
			MIN	MAX		
Timing requirements	tsu(P-E)	Port Input Setup Time	100		ns	[1]
	th(E-P)	Port Input Hold Time	0		ns	[2]
Switching characteristics	td(E-P)	Port Data Output Delay Time		100	ns	[3]



**Figure 23.9.4 Input/Output Port Timing**

#### (5) Serial interface

a) CSIO mode, with internal clock selected

	Symbol	Parameter	Rated Value		Unit	See Fig.
			MIN	MAX		
Timing requirements	tsu(D-CLK)	RXD Input Setup Time	When 3 point sampling is invalid	80	ns	[4]
			When 3 point sampling is valid	80+tc(BCLK)		
	th(CLK-D)	RXD Input Hold Time	15+tc(BCLK)	ns	[5]	
Switching characteristics	td(CLK-D)	TXD Output Delay Time		50	ns	[6]
	th(CLK-D)	TXD Hold Time	0		ns	[98]

b) CSIO mode, with external clock selected

	Symbol	Parameter	Rated Value		Unit	See Fig.
			MIN	MAX		
Timing requirements	tc(CLK)	CLK Input Cycle Time	16 x tc(BCLK)		ns	[7]
	tw(CLKH)	CLK Input "H" Pulse Width	5 x tc(BCLK)		ns	[8]
	tw(CLKL)	CLK Input "L" Pulse Width	5 x tc(BCLK)		ns	[9]
	tsu(D-CLK)	RXD Input Setup Time	50		ns	[10]
	th(CLK-D)	RXD Input Hold Time	55+tc(BCLK)		ns	[11]
Switching characteristics	td(CLK-D)	TXD Output Delay Time	When 3 point sampling is invalid	85+2tc(BCLK)	ns	[12]
			When 3 point sampling is valid	85+3tc(BCLK)		

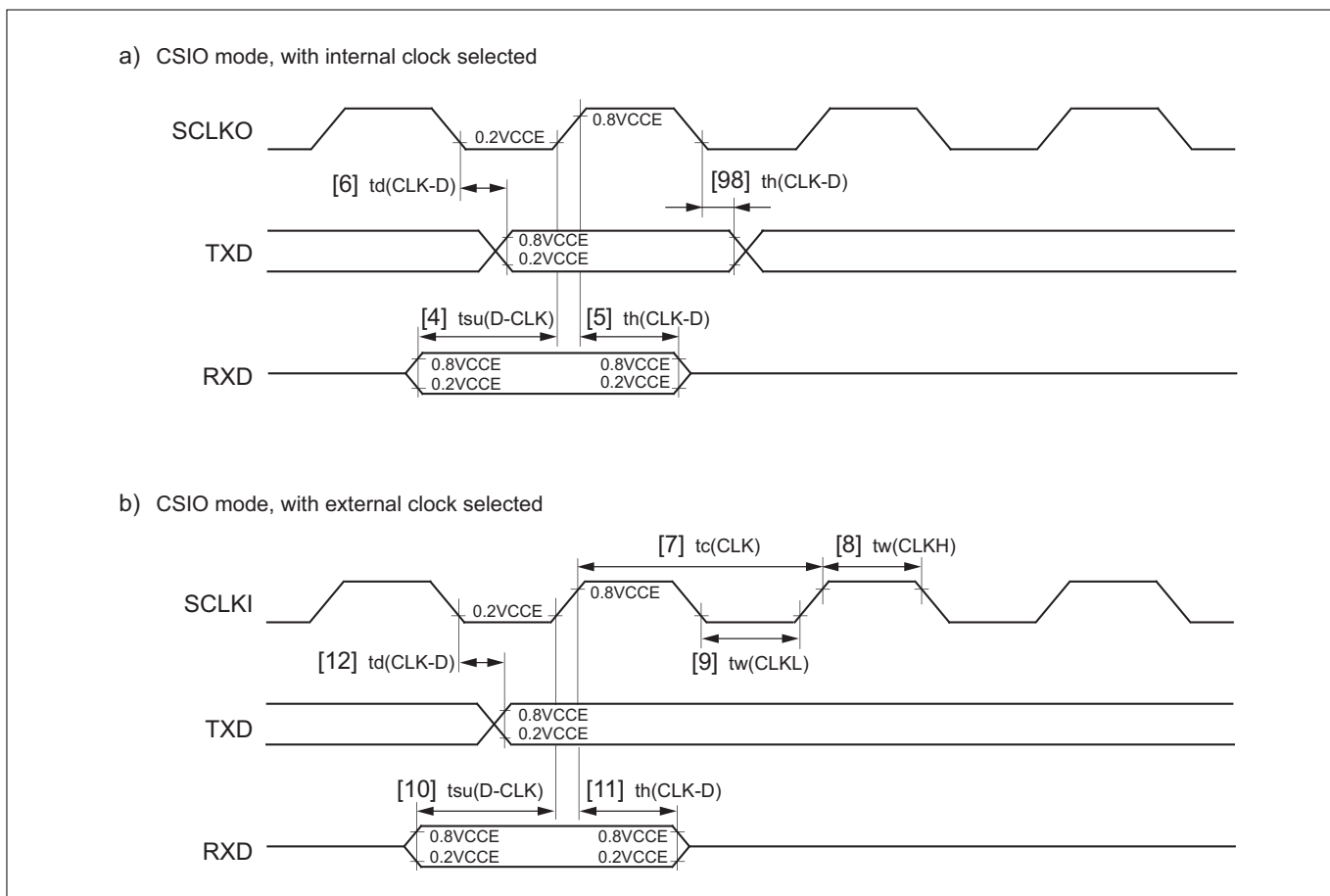


Figure 23.9.5 Serial Interface Timing

#### (6) SBI

	Symbol	Parameter	Rated Value		Unit	See Fig.
			MIN	MAX		
Timing requirements	tw(SBIL)	SBI# Input Pulse Width	$5 \times \frac{tc(BCLK)}{2}$		ns	[13]

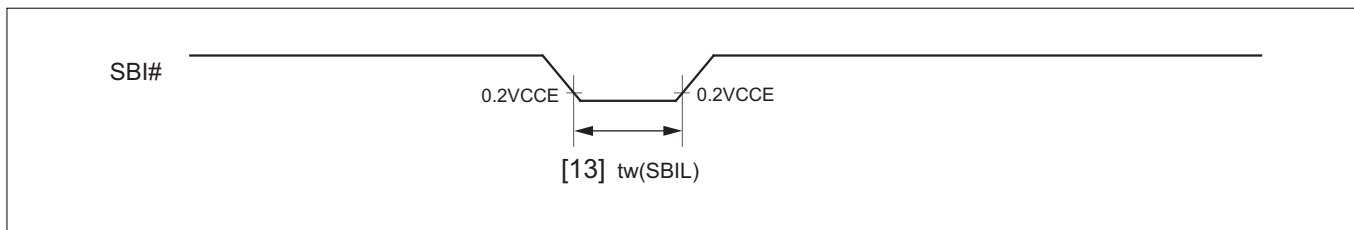


Figure 23.9.6 SBI Timing

#### (7) TIN

	Symbol	Parameter	Rated Value		Unit	See Fig.	
			MIN	MAX			
Timing requirements	tw(TIN)	TIN Input Pulse Width	When BCLK/4 is selected (Note 1)	$7 \times tc(BCLK)$		ns	[14]
			When BCLK/4 is not selected (Note 1)	$7 \times \frac{tc(BCLK)}{2}$			

Note 1: TIN24, 25, PWMOFF0 are selected in TOU0 control register 1 (TOU0CR1) PRS3CKS bit, TIN26, 27, PWMOFF1 are selected in TOU1 control register 1 (TOU1CR1) PRS4CKS bit, other TIN are selected in common count clock select register (CNTCKSEL) PRS012CKS bit.

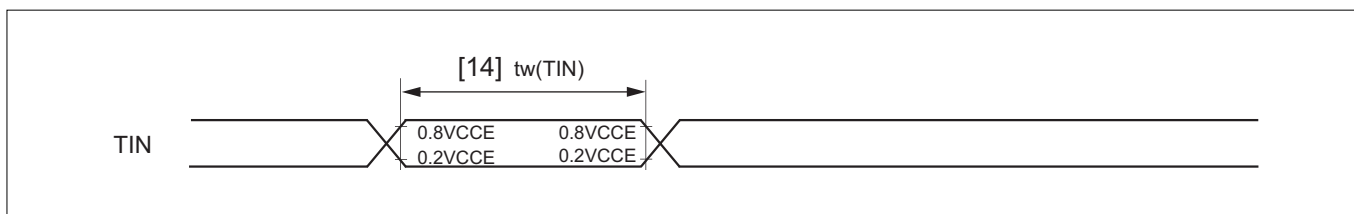


Figure 23.9.7 TIN Timing

#### (8) TO

	Symbol	Parameter	Rated Value		Unit	See Fig. 23.9.8
			MIN	MAX		
Switching characteristics	td(BCLK-TO)	TO Output Delay Time		100	ns	[15]

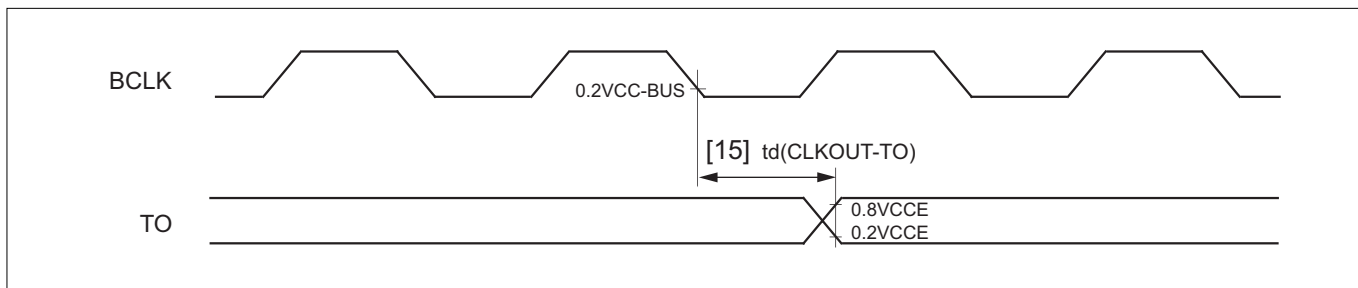


Figure 23.9.8 TO Timing

#### (9) TCLK

	Symbol	Parameter	Rated Value		Unit	See Fig. 23.9.9	
			MIN	MAX			
Timing requirements	tw(TCLKH)	TCLK Input "H" Pulse Width	When BCLK/4 is selected (Note 1)	$7 \times tc(BCLK)$		ns	[99]
			When BCLK/2 is selected (Note 1)	$7 \times \frac{tc(BCLK)}{2}$			
	tw(TCLKL)	TCLK Input "L" Pulse Width	When BCLK/4 is selected (Note 1)	$7 \times tc(BCLK)$		ns	[100]
			When BCLK/2 is selected (Note 1)	$7 \times \frac{tc(BCLK)}{2}$			

Note 1: Selected in common count clock select register (CNTCKSEL) PRS012CKS bit.

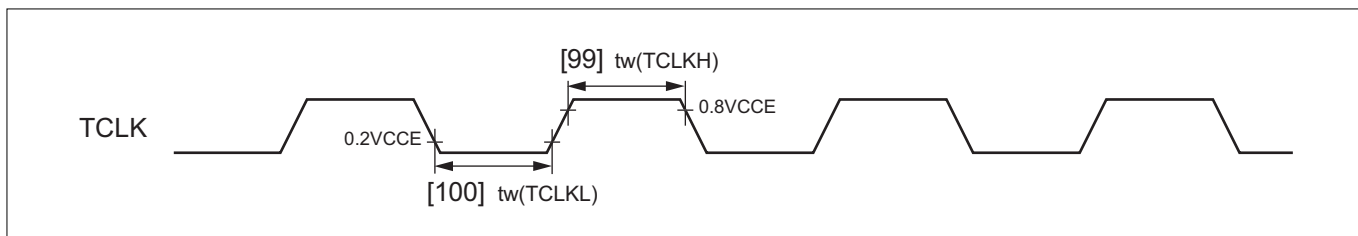


Figure 23.9.9 TCLK Timing

## (10) Read and write timing (1/4)

	Symbol	Parameter	Rated Value		Unit	See Figs. 23.9.10 23.9.11
			MIN	MAX		
Timing requirements	tsu(D-CLKOUTH)	Data Input Setup Time before CLKOUT	26		ns	[31]
	th(CLKOUTH-D)	Data Input Hold Time after CLKOUT	0		ns	[32]
	tsu(WAITL-CLKOUTH)	WAIT# Input Setup Time before CLKOUT	26		ns	[33]
	th(CLKOUTH-WAITL)	WAIT# Input Hold Time after CLKOUT	0		ns	[34]
	tsu(WAITH-CLKOUTH)	WAIT# Input Setup Time before CLKOUT	26		ns	[78]
	th(CLKOUTH-WAITH)	WAIT# Input Hold Time after CLKOUT	0		ns	[79]
Switching characteristics	tv(CLKOUTH-BLWL) tv(CLKOUTH-BHWL)	Write Valid Time after CLKOUT (with zero wait state)	-5		ns	[90]
	td(CLKOUTH-RDL)	Read Delay Time after CLKOUT (when either SWAIT or CWAIT = 1)		12	ns	[92]
	td(CLKOUTH-BLWL) td(CLKOUTH-BHWL)	Write Delay Time after CLKOUT (byte write mode) (when either SWAIT or CWAIT = 1)		13	ns	[112]
	td(CLKOUTL-BLWH) td(CLKOUTL-BHWH)	Write Delay Time after CLKOUT		14	ns	[97]
	tc(CLKOUT)	CLKOUT Output Cycle Time		$\frac{tc(XIN)}{2}$	ns	[16]
	tw(CLKOUTH)	CLKOUT Output "H" Pulse Width	$\frac{tc(CLKOUT)}{2} - 5$		ns	[17]
	tw(CLKOUTL)	CLKOUT Output "L" Pulse Width	$\frac{tc(CLKOUT)}{2} - 5$		ns	[18]
	td(CLKOUTH-A)	Address Delay Time after CLKOUT		24	ns	[19]
	td(CLKOUTH-CS)	Chip Select Delay Time after CLKOUT (When CWAIT=0)		24	ns	[20]
	td(CLKOUTL-CSL)	Chip Select Delay Time after CLKOUT (When CWAIT=1)		24	ns	[113]
	tv(CLKOUTH-A)	Address Valid Time after CLKOUT	-5		ns	[21]
	tv(CLKOUTH-CS)	Chip Select Valid Time after CLKOUT	-5		ns	[22]
	td(CLKOUTL-RDL)	Read Delay Time after CLKOUT (When both SWAIT and CWAIT=0 or both SWAIT and CWAIT=1)		10	ns	[23]
	tv(CLKOUTH-RDL)	Read Valid Time after CLKOUT	-5		ns	[24]
	td(CLKOUTL-BLWL) td(CLKOUTL-BHWL)	Write Delay Time after CLKOUT (When both SWAIT and CWAIT=0 or both SWAIT and CWAIT=1)		11	ns	[25]
	tv(CLKOUTL-BLWL) tv(CLKOUTL-BHWL)	Write Valid Time after CLKOUT	-5		ns	[26]
	td(CLKOUTL-D)	Data Output Delay Time after CLKOUT		0 wait state:11 1-plus wait states:18	ns	[27]
	tv(CLKOUTH-D)	Data Output Valid Time after CLKOUT	0 wait state: -4 1-plus wait states: -10		ns	[28]
	tpzx(CLKOUTL-DZ)	Data Output Enable Time after CLKOUT	-10		ns	[29]
	tpxz(CLKOUTH-DZ)	Data Output Disable Time after CLKOUT		5	ns	[30]
tw(CSH)	Chip Select "H" Pulse Width	C=0: (tc(CLKOUT)xID)-15ID C=1: $tc(CLKOUT) (\frac{1}{2} + ID) - 15$		ns	[114]	



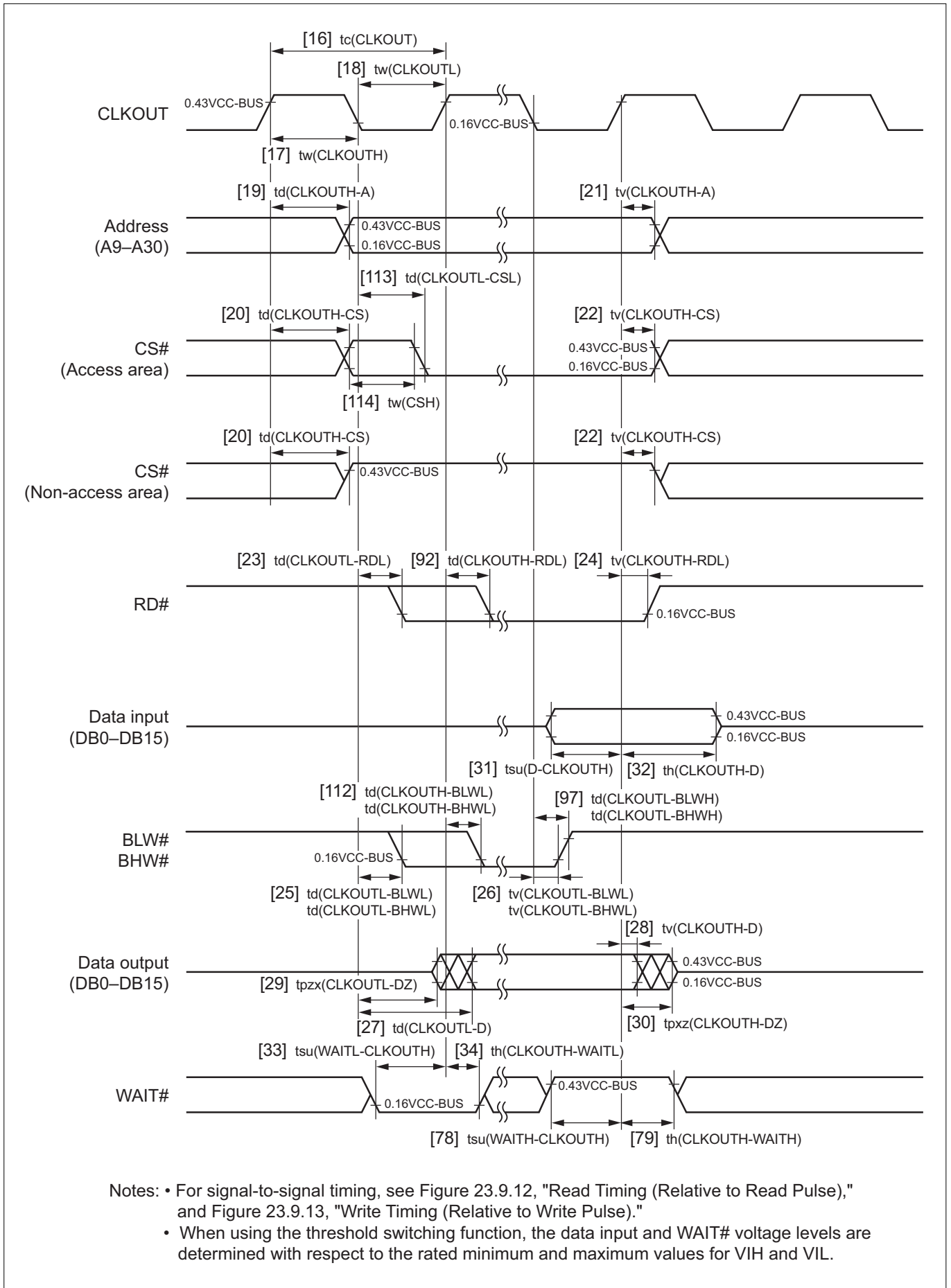


Figure 23.9.10 Read and Write Timing (Relative to CLKOUT) with 1 or More Wait States

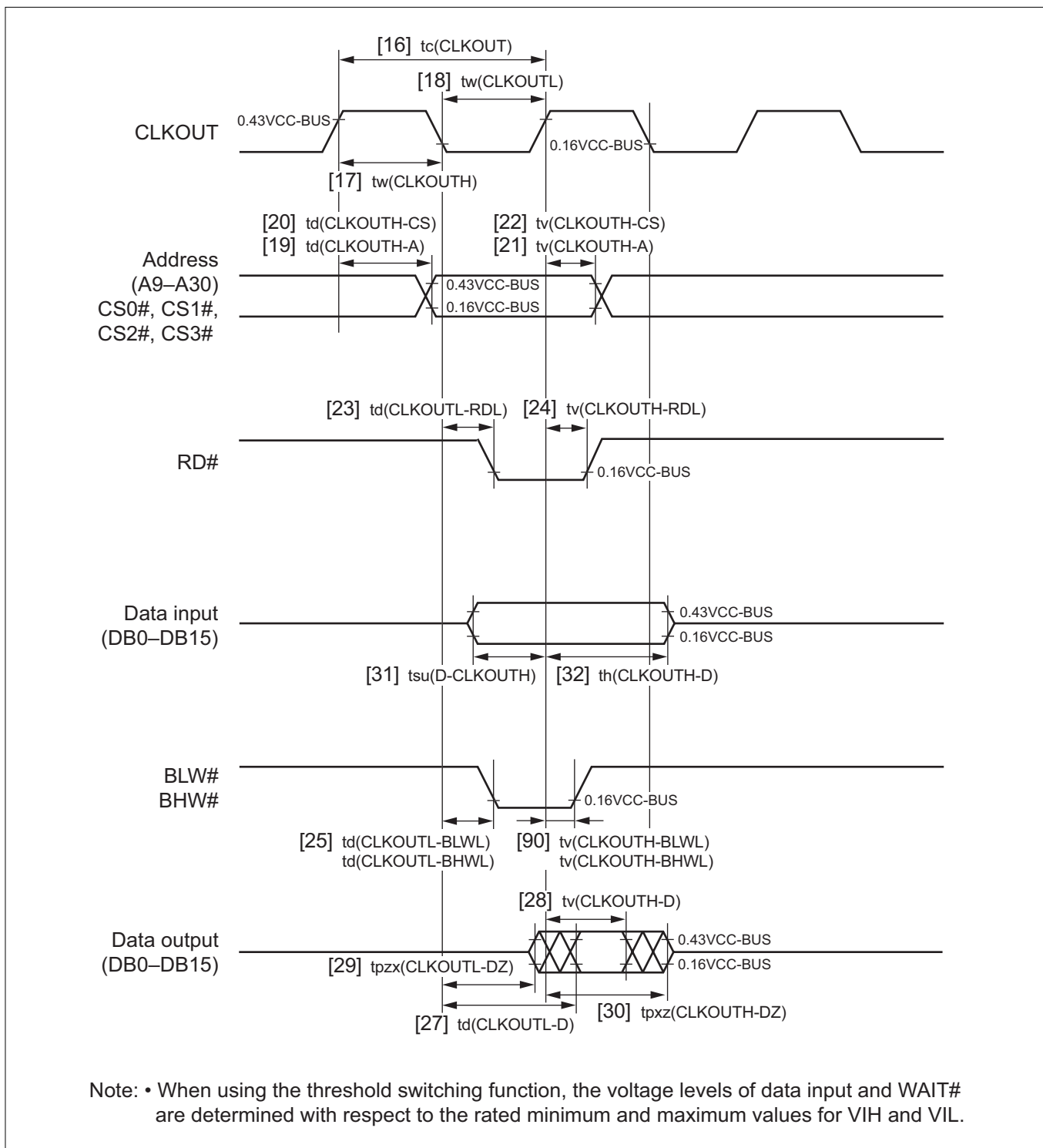


Figure 23.9.11 Read and Write Timing (Relative to CLKOUT) with Zero Wait State

#### (11) Read and write timing (2/4)

	Symbol	Parameter	Rated Value		Unit	See Figs. 23.9.12 23.9.13
			MIN	MAX		
Timing requirements	tsu(D-RDH)	Data Input Setup Time before Read	30		ns	[44]
	th(RDH-D)	Data Input Hold Time after Read	0		ns	[45]
	tsu(WAITH-RDL) tsu(WAITL-RDL)	Wait Input Setup Time before Read	tc(CLKOUT)+21		ns	[132]
	tw(WAITH)	Wait "H" Pulse Width (Note 1)	26		ns	[133]
	tw(WAITL)	Wait "L" Pulse Width (Note 1)	26		ns	[134]
	tsu(WAITH-BLWL) tsu(WAITH-BHWL) tsu(WAITL-BLWL) tsu(WAITL-BHWL)	Wait Input Setup Time before Write (byte write mode)	$\frac{tc(CLKOUT)}{2} + 21$		ns	[135]
Switching characteristics	tw(RDH)	Read "H" Pulse Width	$\frac{tc(CLKOUT)}{2} (1+C+S) - 5$		ns	[55]
	tw(RDL)	Read "L" Pulse Width	$\frac{tc(CLKOUT)}{2} (1+2W-C-S) - 20$		ns	[43]
	tw(BLWL) tw(BHWL)	Write "L" Pulse Width (byte write mode)	0 wait state: $\frac{tc(CLKOUT)}{2} - 8$ 1-plus wait states: $\frac{tc(CLKOUT)}{2} (2W-C-S) - 20$		ns	[51]
	td(RDH-BLWL) td(RDH-BHWL)	Write Delay Time after Read	$tc(CLKOUT) \left( \frac{1+C+S}{2} + R + ID \right) - 10$		ns	[56]
	td(BLWH-RDL) td(BHWH-RDL)	Read Delay Time after Write	0 wait state: $\frac{tc(CLKOUT)}{2} - 10$ 1-plus wait states: $tc(CLKOUT) \left( 1 + R + \frac{C+S}{2} \right) - 10$		ns	[57]
	td(CSL-RDL)	Chip Select Delay Time before Read	$\frac{tc(CLKOUT)}{2} (1+S) - 16$		ns	[93]
	td(CSL-BLWL) td(CSL-BHWL)	Chip Select Delay Time before Write	$\frac{tc(CLKOUT)}{2} (1+S) - 15$		ns	[95]
	td(A-RDL)	Address Delay Time before Read	$\frac{tc(CLKOUT)}{2} (1+C+S) - 15$		ns	[39]
	td(CS-RDL)	Chip Select Delay Time before Read	$\frac{tc(CLKOUT)}{2} (1+S) - 15$		ns	[40]
	tv(RDH-A)	Address Valid Time after Read	tc(CLKOUT)(R+ID)		ns	[41]
	tv(RDH-CS)	Chip Select Valid Time after Read	tc(CLKOUT) × R		ns	[42]
	tpzx(RDH-DZ)	Data Output Enable Time after Read	tc(CLKOUT) $\left( \frac{1}{2} + R + ID \right)$		ns	[46]
	td(A-BLWL) td(A-BHWL)	Address Delay Time before Write (byte write mode)	$\frac{tc(CLKOUT)}{2} (1+C+S) - 15$		ns	[47]
	td(CS-BLWL) td(CS-BHWL)	Chip Select Delay Time before Write (byte write mode)	$\frac{tc(CLKOUT)}{2} (1+S) - 15$		ns	[48]
	tv(BLWH-A) tv(BHWH-A)	Address Valid Time after Write (byte write mode)	0 wait state: -5 1-plus wait states: $tc(CLKOUT) \left( \frac{1}{2} + R \right) - 5$		ns	[49]
	tv(BLWH-CS) tv(BHWH-CS)	Chip Select Valid Time after Write (byte write mode)	0 wait state: -5 1-plus wait states: $tc(CLKOUT) \left( \frac{1}{2} + R \right) - 5$		ns	[50]
	td(BLWL-D) td(BHWL-D)	Data Output Delay Time after Write (byte write mode)		0 wait state: 5 1-plus wait states: $15 - \frac{tc(CLKOUT)}{2} (S+C)$	ns	[52]

Note 1: Hold a level during tw(WAITH), tw(WAITL) from the position of the minimum value of tsu(WAITH-RDL), tsu(WAITL-RDL), tsu(WAITH-BLWL), tsu(WAITH-BHWL), tsu(WAITL-BLWL), and tsu(WAITL-BHWL).

	Symbol	Parameter	Rated Value		Unit	See Figs. 23.9.12 23.9.13
			MIN	MAX		
Switching characteristics	tv(BLWH-D) tv(BHWH-D)	Data Output Valid Time after Write (byte write mode)	0 wait state: -7 1-plus wait states: $t_c(\text{CLKOUT})(\frac{1}{2} + R) - 13$		ns	[53]
	tpzx(BLWL-DZ) tpzx(BHWL-DZ)	Data Output Enable Time after Write (byte write mode)	0 wait state: -20 1-plus wait states: $-22 - \frac{t_c(\text{CLKOUT})}{2} (S+C)$		ns	[126]
	tpxz(BLWH-DZ) tpxz(BHWH-DZ)	Data Output Disable Time after Write (byte write mode)		0 wait state: 5 1-plus wait states: $t_c(\text{CLKOUT})(\frac{1}{2} + R) + 5$		ns

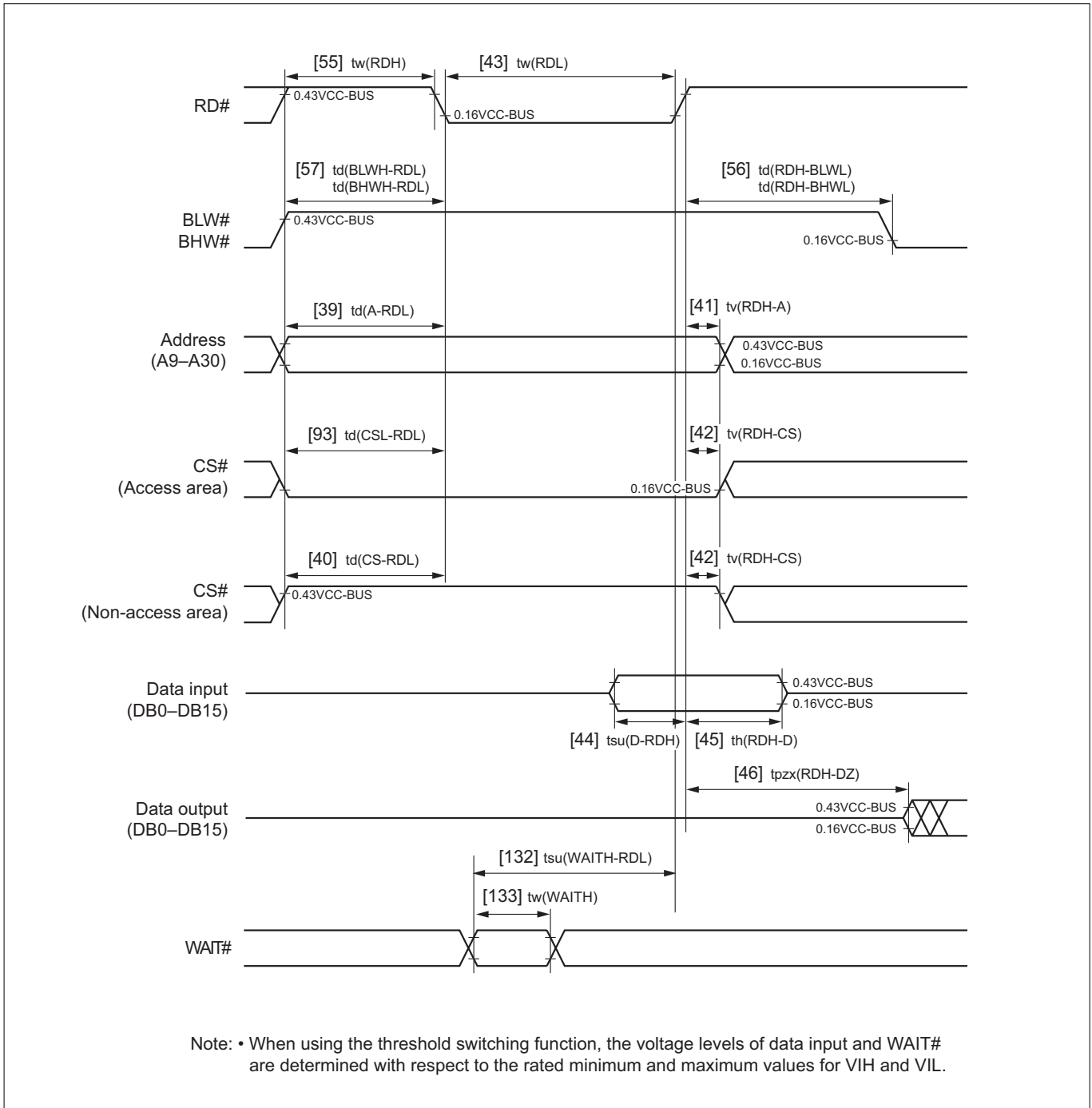


Figure 23.9.12 Read Timing (Relative to Read Pulse)

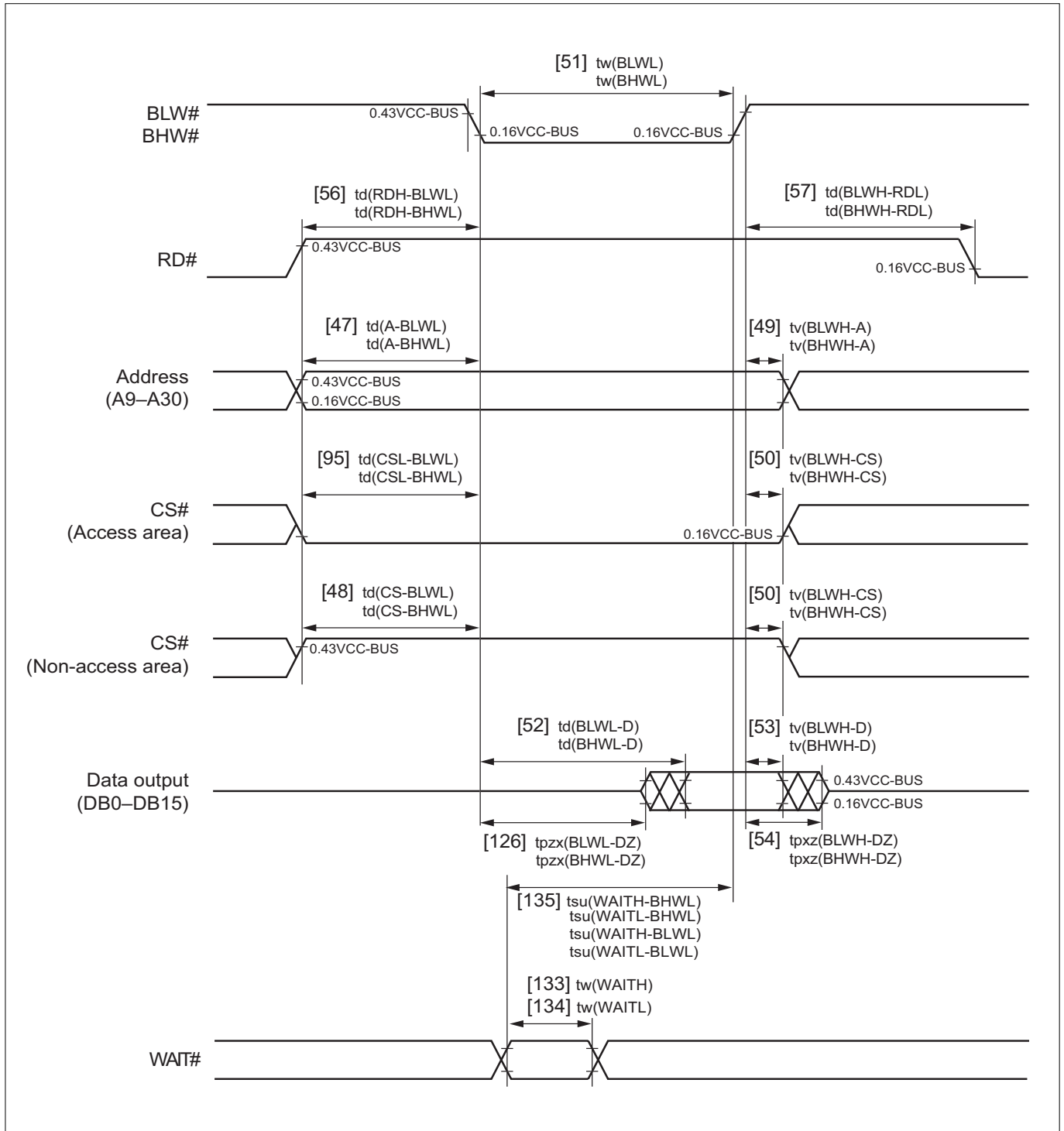


Figure 23.9.13 Write Timing (Relative to Write Pulse)

## (12) Read and write timing (3/4)

	Symbol	Parameter	Rated Value		Unit	See Figs. 23.9.14
			MIN	MAX		
Timing requirements	tsu(D-RDH)	Data Input Setup Time before Read	30		ns	[44]
	th(RDH-D)	Data Input Hold Time after Read	0		ns	[45]
Switching characteristics	td(A-RDL)	Address Delay Time before Read	$\frac{tc(\text{CLKOUT})}{2} (1+C+S)-15$		ns	[39]
	td(CS-RDL)	Chip Select Delay Time before Read	$\frac{tc(\text{CLKOUT})}{2} (1+S)-15$		ns	[40]
	tv(RDH-A)	Address Valid Time after Read	$tc(\text{CLKOUT}) \times (R+ID)$		ns	[41]
	tv(RDH-CS)	Chip Select Valid Time after Read	$tc(\text{CLKOUT}) \times R$		ns	[42]
	tw(RDL)	Read "L" Pulse Width	$\frac{tc(\text{CLKOUT})}{2} (1+2W-C-S)-20$		ns	[43]
	tpzx(RDH-DZ)	Data Output Enable Time after Read	$tc(\text{CLKOUT}) \left(\frac{1}{2} + R+ID\right)$		ns	[46]
	td(RDH-WRL)	Write Delay time after Read (byte write mode)	$tc(\text{CLKOUT}) \left(\frac{1+C+S}{2} + R+ID\right) - 10$		ns	[80]
	td(WRH-RDL)	Read Delay time after Write (byte write mode)	During 0 wait: $\frac{tc(\text{CLKOUT})}{2} - 20$ During 1 wait: $tc(\text{CLKOUT}) \left(1+R+\frac{C+S}{2}\right) - 20$		ns	[81]
	td(CSL-RDL)	Chip select Delay time before Read	$\frac{tc(\text{CLKOUT})}{2} (1+S)-16$		ns	[93]
	td(BLEL-RDL) td(BHEL-RDL)	Byte Enable Delay Time before Read (byte write mode)	$\frac{tc(\text{CLKOUT})}{2} \times (1+S)-20$		ns	[136]
	tv(RDH-BLEL) tv(RDH-BHEL)	Valid Time after Read (byte write mode)	$tc(\text{CLKOUT}) \times R - 5$		ns	[137]

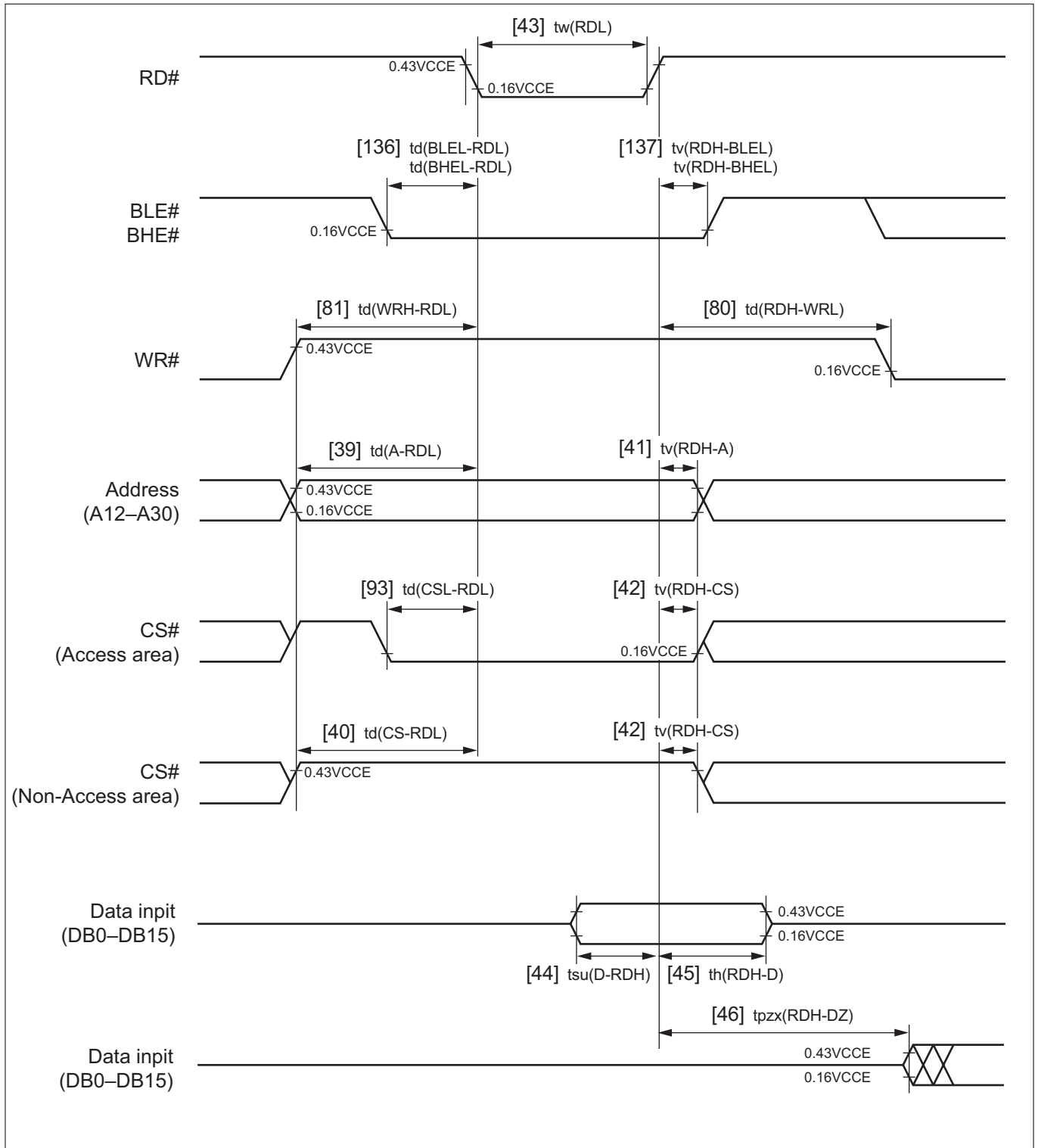


Figure 23.9.14 Read Timing (Byte Enable Mode)

## (13) Read and write timing (4/4)

	Symbol	Parameter	Rated Value		Unit	See Fig. 23.9.15
			MIN	MAX		
Switching characteristics	tw(WRL)	Write "L" Pulse Width (byte enable mode)	0 wait state: $\frac{tc(\text{CLKOUT})}{2} - 6$ 1-plus wait states: $\frac{tc(\text{CLKOUT})}{2} (2W-C-S)-20$		ns	[68]
	td(RDH-WRL)	Write Delay Time after Read (byte enable mode)	$tc(\text{CLKOUT})\left(\frac{1+C+S}{2}+R+D\right)-10$		ns	[80]
	td(WRH-RDL)	Read Delay Time after Write (byte enable mode)	0 wait state: $\frac{tc(\text{CLKOUT})}{2} - 20$ 1-plus wait states: $tc(\text{CLKOUT})\left(1+R+\frac{C+S}{2}\right)-20$		ns	[81]
	td(CSL-WRL)	Chip Select Delay Time before Write (byte enable mode)	$\frac{tc(\text{CLKOUT})}{2} (1+S) - 15$		ns	[96]
	td(A-WRL)	Address Delay Time before Write (byte enable mode)	$\frac{tc(\text{CLKOUT})}{2} (1+C+S)-15$		ns	[69]
	td(CS-WRL)	Chip Select Delay Time before Write (byte enable mode)	$\frac{tc(\text{CLKOUT})}{2} (1+S) - 15$		ns	[70]
	tv(WRH-A)	Address Valid Time after Write (byte enable mode)	0 wait state: -5 1-plus wait states: $tc(\text{CLKOUT})\left(\frac{1}{2}+R\right) - 5$		ns	[71]
	tv(WRH-CS)	Chip Select Valid Time after Write (byte enable mode)	0 wait state: -5 1-plus wait states: $tc(\text{CLKOUT})\left(\frac{1}{2}+R\right) - 5$		ns	[72]
	td(BLEL-WRL) td(BHEL-WRL)	Byte Enable Delay Time before Write (byte enable mode)	$\frac{tc(\text{CLKOUT})}{2} (1+S) - 15$		ns	[73]
	tv(WRH-BLEL) tv(WRH-BHEL)	Byte Enable Valid Time after Write (byte enable mode)	0 wait state: -5 1-plus wait states: $tc(\text{CLKOUT})\left(\frac{1}{2}+R\right) - 5$		ns	[74]
	td(WRL-D)	Data Output Delay Time after Write (byte enable mode)		0 wait state: 7 1-plus wait states: $15 - \frac{tc(\text{CLKOUT})}{2} (S+C)$	ns	[75]
	tv(WRH-D)	Data Output Valid Time after Write (byte enable mode)	0 wait state : -7 1-plus wait states: $tc(\text{CLKOUT})\left(\frac{1}{2}+R\right)-13$		ns	[76]
	tpzx(WRH-DZ)	Data Output Enable Time after Write (byte enable mode)	0 wait state:-20 1-plus wait states: $-22 - \frac{tc(\text{CLKOUT})}{2} (S+C)$		ns	[127]
	tpxz(WRH-DZ)	Data Output Disable Time after Write (byte enable mode)		0 wait state: 5 1-plus wait states: $tc(\text{CLKOUT})\left(\frac{1}{2}+R\right) + 5$	ns	[77]



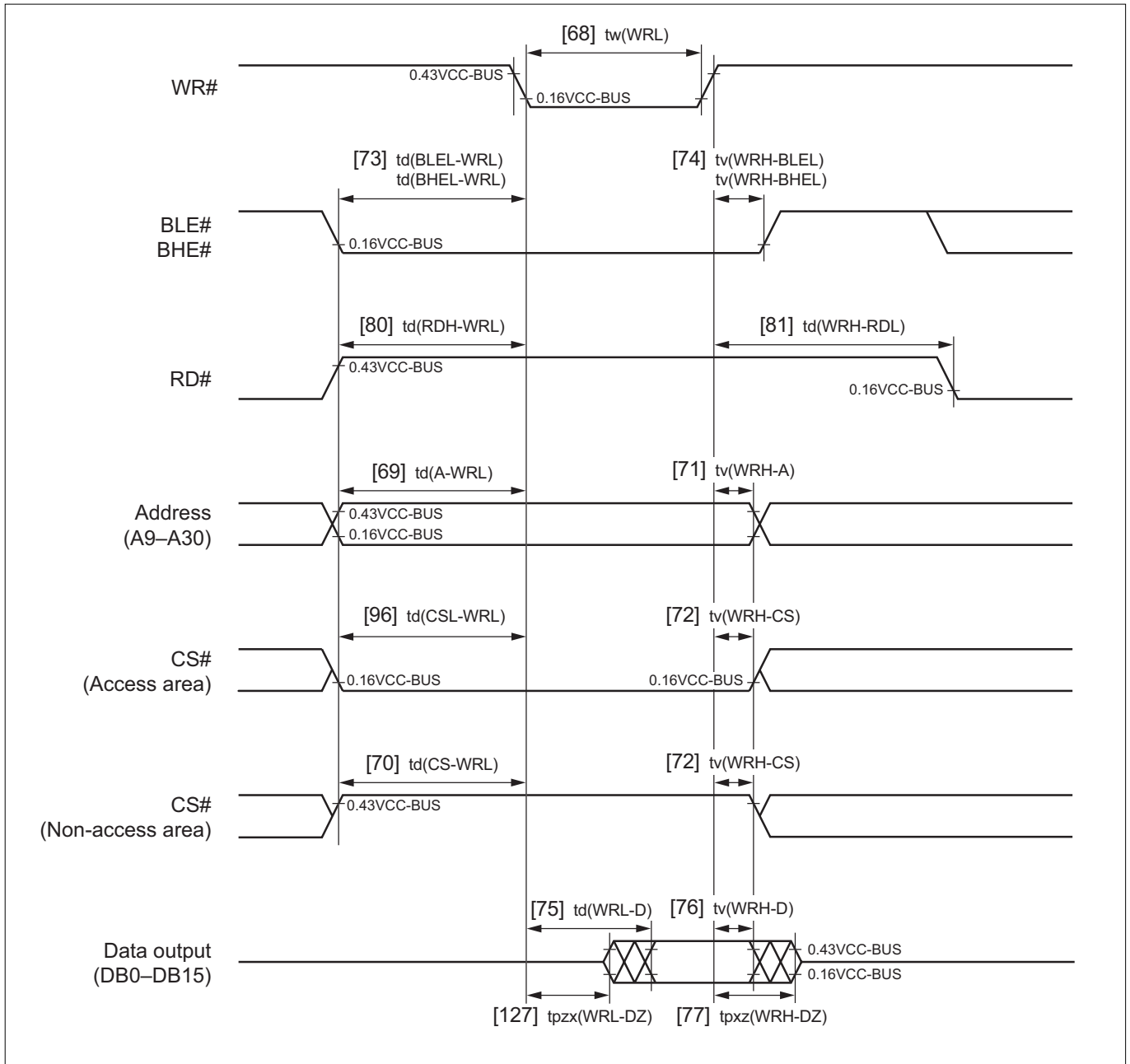


Figure 23.9.15 Write Timing (Byte Enable Mode)

#### (14) Bus arbitration timing

	Symbol	Parameter	Rated Value		Unit	See Fig.
			MIN	MAX		
Timing requirements	tsu(HREQ#-CLKOUTH)	HREQ# Input Setup Time before CLKOUTH	27		ns	[35]
	th(CLKOUTH-HREQ#)	HREQ# Input Hold Time after CLKOUTH	0		ns	[36]
Switching characteristics	td(CLKOUTL-HACKL)	HACK# Delay Time after CLKOUTH		29	ns	[37]
	tv(CLKOUTL-HACKL)	HACK# Valid Time after CLKOUTH	-11		ns	[38]

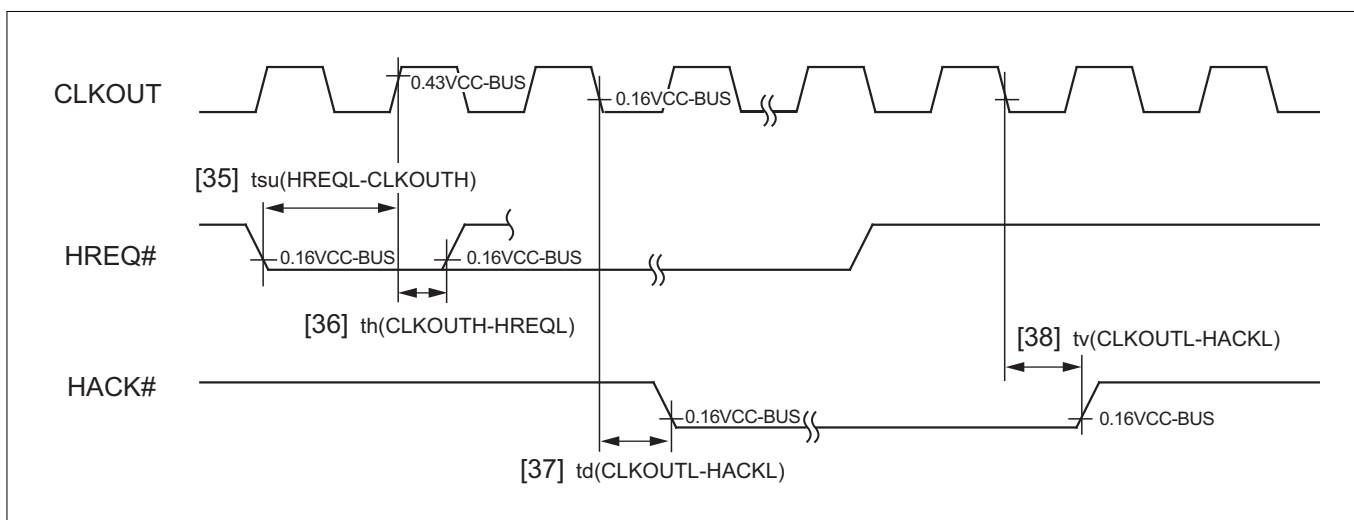


Figure 23.9.16 Bus Arbitration Timing

#### (15) JTAG interface timing

	Symbol	Parameter	Measurement condition	Rated Value		Unit	See Fig. 23.9.17
				MIN	MAX		
Timing requirements	tc(JTCK)	JTCK Input Cycle Time		100		ns	[60]
	tw(JTCKH)	JTCK Input "H" Pulse Width		40		ns	[61]
	tw(JTCKL)	JTCK Input "L" Pulse Width		40		ns	[62]
	tsu(JTDI-JTCK)	JTDI, JTMS Input Setup Time		15		ns	[63]
	th(JTCK-JTDI)	JTDI, JTMS Input Hold Time		20		ns	[64]
	tw(JTRST)	JTRST Input "L" Pulse Width		tc(JTCK)		ns	[67]
Switching characteristics	td(JTCK-JTDO)	JTDO Output Delay Time after JTCK	CL=80pF		40	ns	[65]
	tpzx(JTCK-JTDOZ)	JTDO Output Enable Time after JTCK	CL=80pF	5		ns	[128]
	tpxz(JTCK-JTDOZ)	JTDO Output Disable Time after JTCK	CL=80pF		40	ns	[66]
	tv(JTCK-JTDO)	TDO Output Valid Time after JTCK	CL=80pF	5		ns	[129]

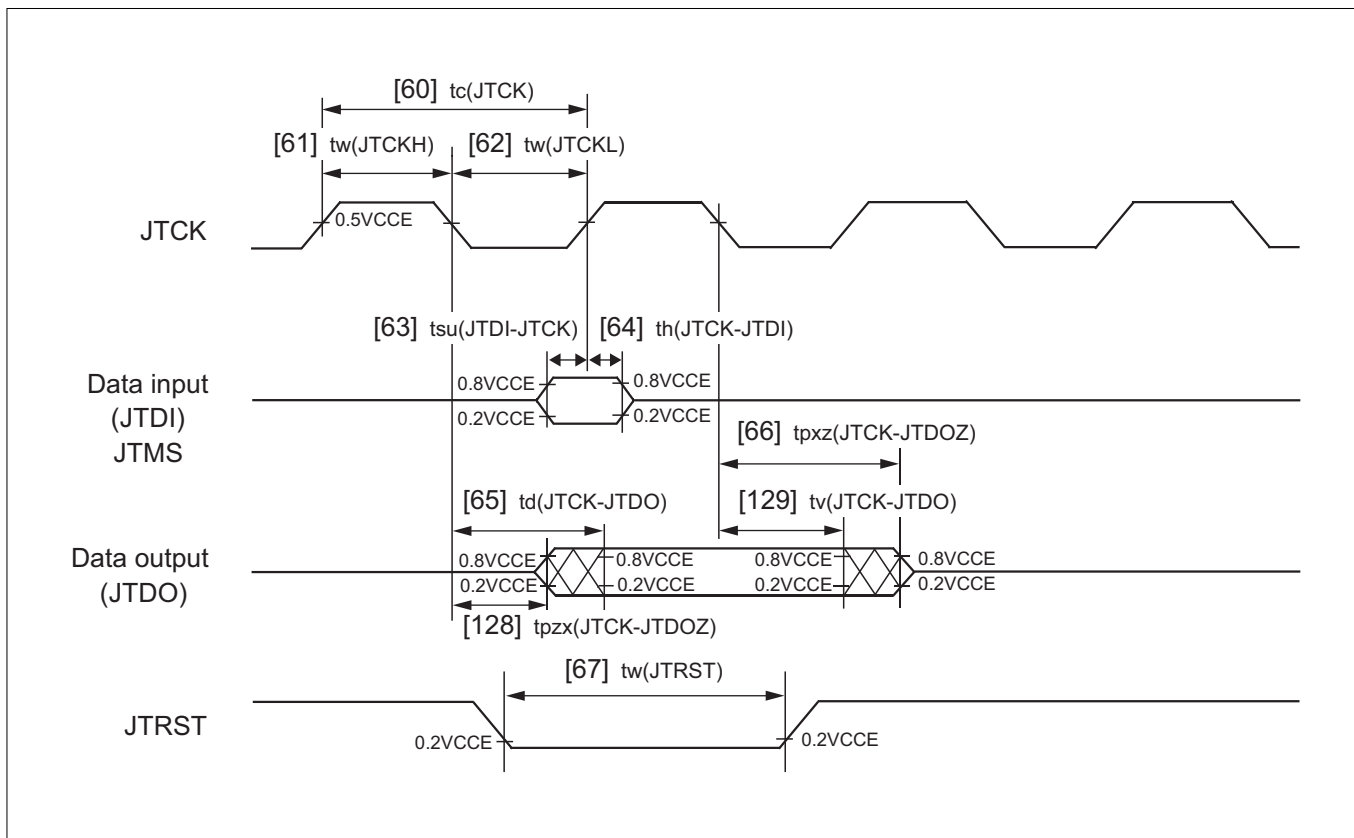


Figure 23.9.17 JTAG Interface Timing

#### (16) RTD timing

	Symbol	Parameter	Rated Value		Unit	See Fig. 23.9.18
			MIN	MAX		
Timing requirements	tc(RTDCLK)	RTDCLK Input Cycle Time	500		ns	[82]
	tw(RTDCLKH)	RTDCLK Input "H" Pulse Width	230		ns	[83]
	tw(RTDCLKL)	RTDCLK Input "L" Pulse Width	230		ns	[84]
	th(RTDCLKH-RTDRXD)	RTDRXD Input Hold Time	50		ns	[88]
	tsu(RTDRXD-RTDCLKL)	RTDRXD Input Setup Time	60		ns	[89]
Switching characteristics	td(RTDCLKH-RTDACK)	RTDACK Delay Time after RTDCLK Input		160	ns	[85]
	tv(RTDCLKL-RTDACK)	RTDACK Valid Time after RTDCLK Input		160	ns	[86]
	td(RTDCLKH-RTDTXD)	RTDTXD Delay Time after RTDCLK Input		160	ns	[87]

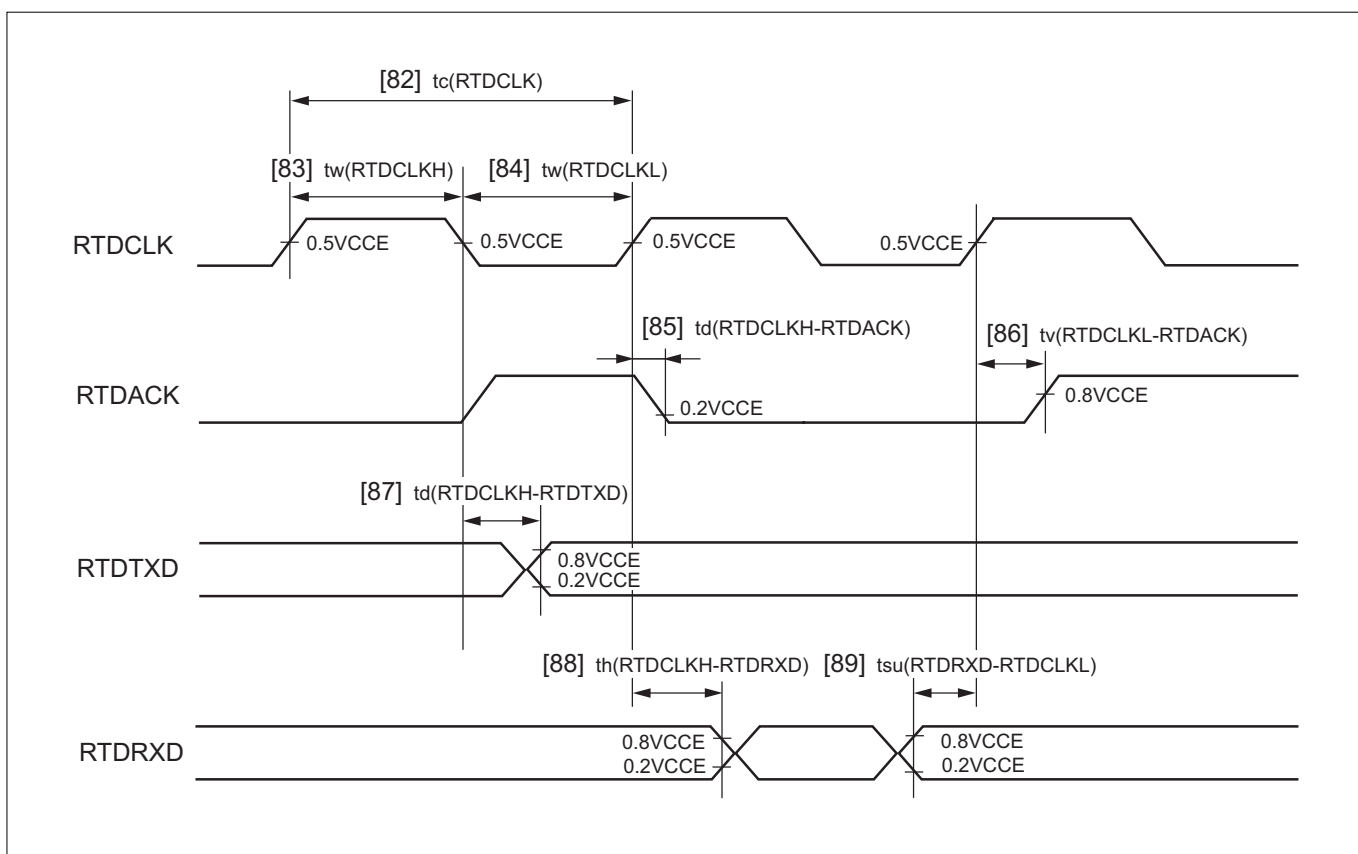


Figure 23.9.18 RTD Timing

#### (17) NBD timing

	Symbol	Parameter	Measurement Condition	Rated Value		Unit	See Fig. 23.9.19
				MIN	MAX		
Timing requirements	tc(NBDCLK)	NBDCLK Input Cycle Time		80		ns	[103]
	tw(NBDCLKL)	NBDCLK Input "L" Pulse Width		35		ns	[104]
	tsu(NBDD-NBDCLKH)	NBDD Input Setup Time before NBDCLK		20		ns	[107]
	th(NBDCLKH-NBDD)	NBDD Input Hold Time after NBDCLK		5		ns	[108]
	tsu(NBDSYNCL-NBDCLKH)	NBDSYNC# Input Setup Time before NBDCLK		20		ns	[109]
	th(NBDCLKH-NBDSYNCL)	NBDSYNC# Input Hold Time after NBDCLK	CL=100pF	5		ns	[110]
Switching characteristics	td(NBDCLKH-NBDD)	NBDD Output Delay Time after NBDCLK	CL=100pF	7	tc(NBDCLK)-20	ns	[105]
	tpzx(NBDCLKH-NBDDZ)	NBDD Output Enable Time after NBDCLK	CL=100pF	5		ns	[130]
	tv(NBDCLKH-NBDD)	NBDD Output Valid Time after NBDCLK	CL=100pF	5		ns	[106]
	tpxz(NBDCLKH-NBDDZ)	NBDD Output Disable Time after NBDCLK	CL=100pF		60	ns	[131]
	tw(NBDEVNTL)	NBDEVNT# Output "L" Pulse Width	CL=100pF	30		ns	[111]

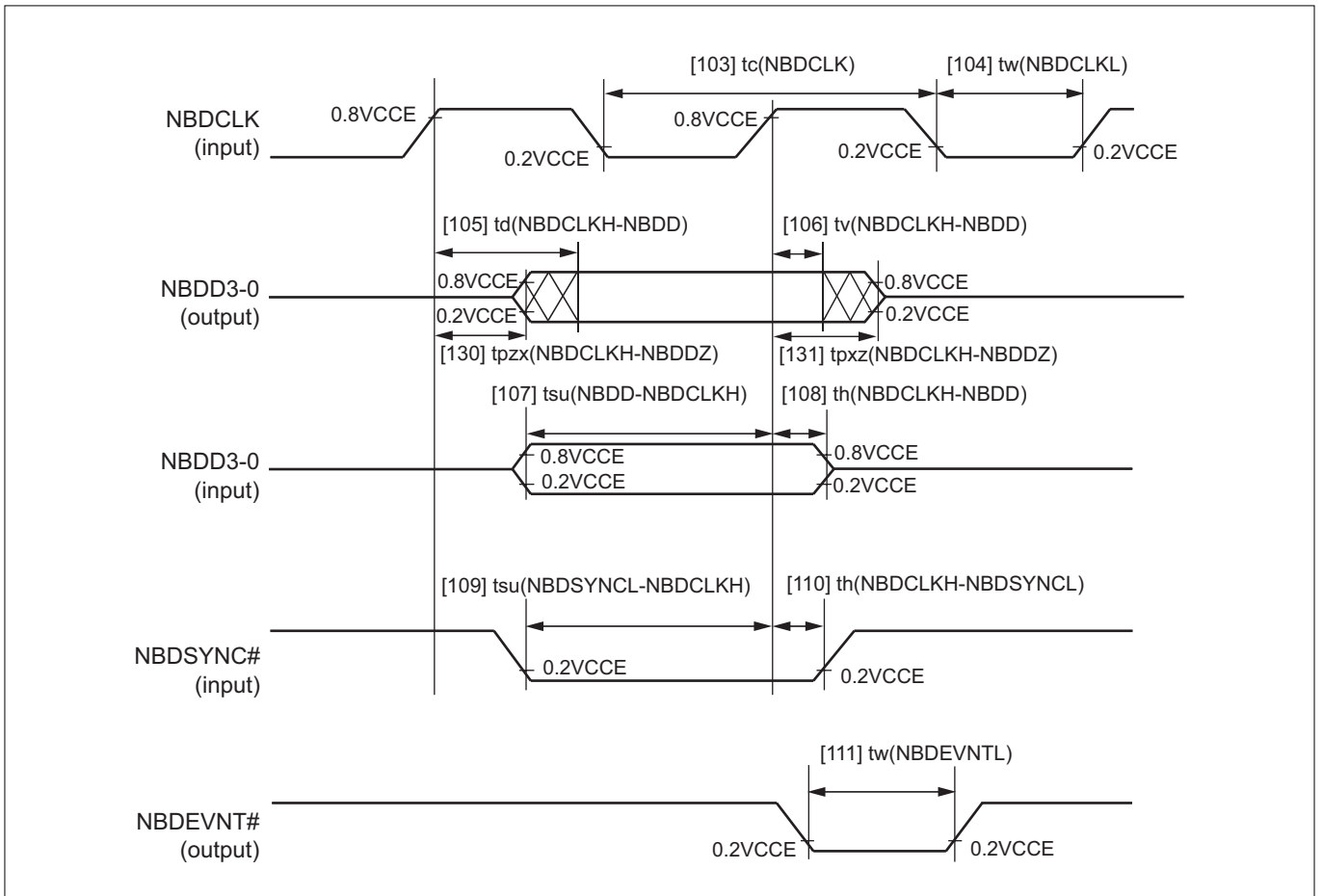


Figure 23.9.19 NBD Timing

## (18) DRI Timing

a) When Special mode is off

	Symbol	Parameter		Rated Value		Unit	See Fig. 23.9.20	
				MIN	MAX			
Timing requirements	tw(DIN)	DIN Input pulse width	DIN0, DIN1, DIN2, DIN3, DIN4	1.5 x tc(BCLK)		ns	[138]	
	tc(DCAP)	Import period	When Input data bus width is 8, 16 bit	3.5 x tc(BCLK)		ns	[139]	
			When Input data bus width is 32 bit	4 x tc(BCLK)		ns		
	tsu(DD-E)	DD Input - Import Edge Set up time (Note 1)	When DIN2, DIN3, DIN4 are selected in Inport event		20		ns	[140]
			When DIN5 is selected in Inport event		40		ns	
	th(E-DD)	Import Edge - DD Input Hold time (Note 1)	When DIN2, DIN3, DIN4 are selected in Inport event		15 + tc(BCLK)		ns	[141]
When DIN5 is selected in Inport event				15 + tc(BCLK)		ns		
ts(E-E)	Edge interval that Event detection is not simultaneous	DIN0, DIN1, DIN2, DIN3, DIN4		15 + tc(BCLK)		ns	[142]	

Note 1: This standard value is when considering Inport timing as a default setup. If it is not, standard value is considered with the point that is shifted back from standard edge for tv(BCLK).

b) When Special mode is on

	Symbol	Parameter		Rated Value		Unit	See Fig. 23.9.20	
				MIN	MAX			
Timing requirements	tw(DIN)	DIN Input pulse width	DIN0, DIN1, DIN2, DIN3, DIN4	1.5 x tc(BCLK)		ns	[138]	
			DIN3	0.8 x tc(BCLK)		ns		
	tc(DCAP)	Import period	When Input data bus width is 8, 16 bit	2 x tc(BCLK)		ns	[139]	
	tsu(DD-E)	DD Input - Import Edge Set up time	When DIN3 is selected in Inport event	20		ns	[140]	
	th(E-DD)	Import Edge - DD Input Hold time	When DIN3 is selected in Inport event	20		ns	[141]	
	ts(E-E)	Edge interval that Event detection is not simultaneous	DIN0, DIN1, DIN2, DIN4		15 + tc(BCLK)		ns	[142]
	tar	Indefinite period of DIN3 Sampling Edge by DIN1 before exiting reset initializing level			20		ns	[143]
tbr	Indefinite period of DIN3 Sampling Edge by DIN1 after exiting reset initializing level			20		ns	[144]	

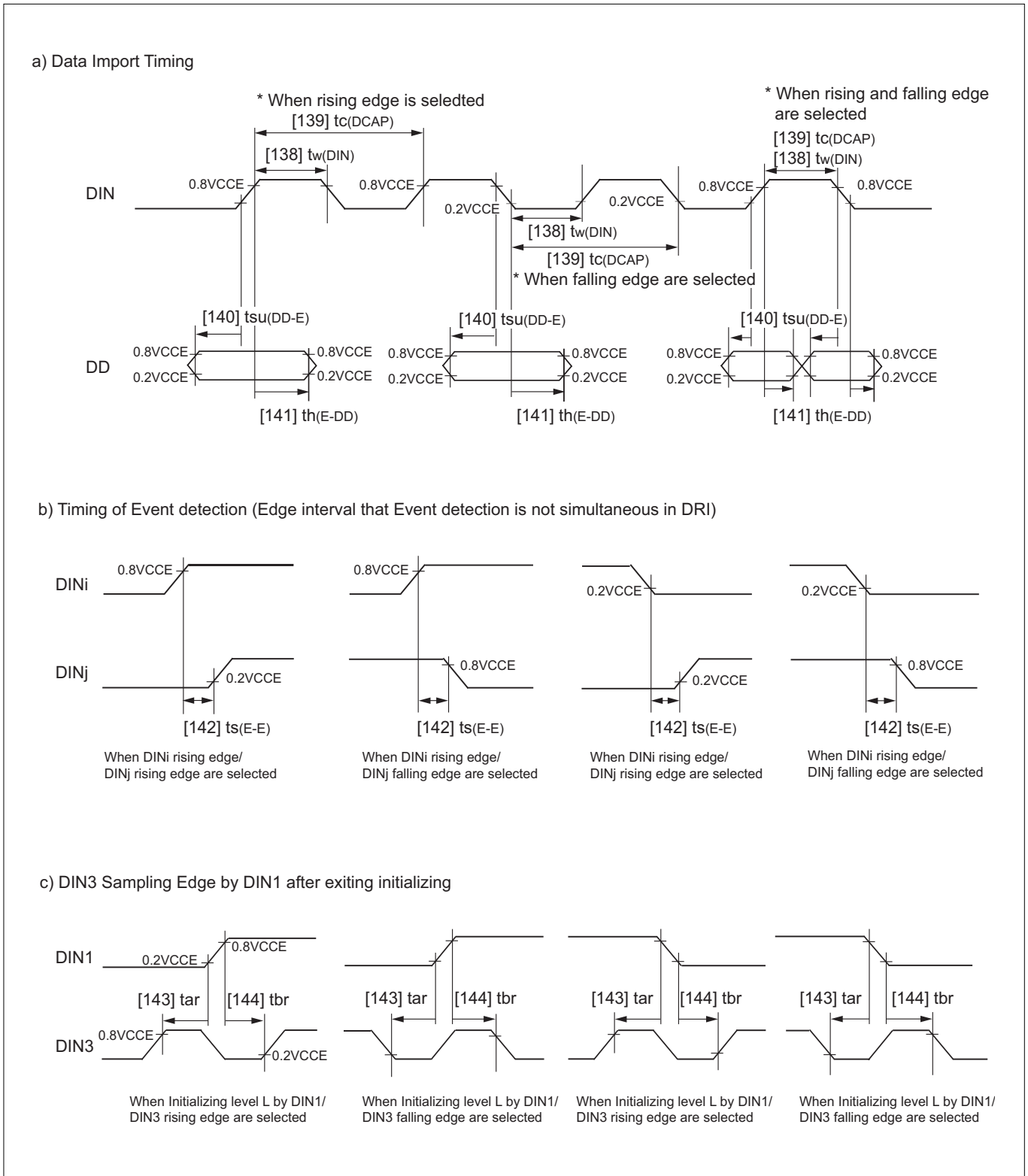


Figure 23.9.20 DRI Timing

#### 23.10 A.C. Characteristics (when VCCE = 3.3 V)

- The timing conditions are referenced to VCCE, VCCER, VCC-BUS, VDDE = 3.3 V ± 0.3 V, Ta = -40°C to 125°C unless otherwise noted.
- The rated values below are guaranteed for the case where the output load capacitance of the measured pins are 15 pF to 50 pF (guaranteed value during centralized capacitance for JTAG related values is 80 pF and for NBD related is 100 pF).
- The terms W, C, S, R and ID in the rated values shown below have the following meaning. For details about CS Area Wait Control Register, see Section 18.2.1, "CS Area Wait Control Registers."
  - W: Number of wait states (selected by the CS Area Wait Control Register WAIT bit)
  - C: "1" when the CS Area Wait Control Register CWAIT bit = 1, or "0" when CWAIT bit = 0
  - S: "1" when the CS Area Wait Control Register SWAIT bit = 1, or "0" when SWAIT bit = 0
  - R: "1" when the CS Area Wait Control Register RECOV bit = 1, or "0" when RECOV bit = 0
  - ID: Number of idle cycles inserted at the end of the bus cycle. Idle cycles may be inserted as specified by the CS Area Wait Control Register IDLE bit, or inserted by default when a write operation is executed immediately after a read (ID = 0 or 1).
- Characteristics of synchronous timing to the external bus clock are values only relative to CLKOUT (none relative to BCLK).
- The CLKOUT/WR# functions are assigned to two separate pins, P70/CLKOUT/WR#/BCLK pins (Pin No.78) and P150/TIN0/CLKOUT/WR# pins (Pin No.133). Unless otherwise noted, characteristics for CLKOUT pin/WR# pin are values of Pin No.133.
- The output drive capability is a value under the following conditions. For output drive capability setting, see Section 8.5, "Port Output Drive Capability Setting Function."
  - CLKOUT pin/WR# pin (Pin No.133): high drive power selected
  - The rest of the output pins: low drive power (the value upon exiting reset) selected

#### (1) Output Switching Characteristics Measurement Circuit

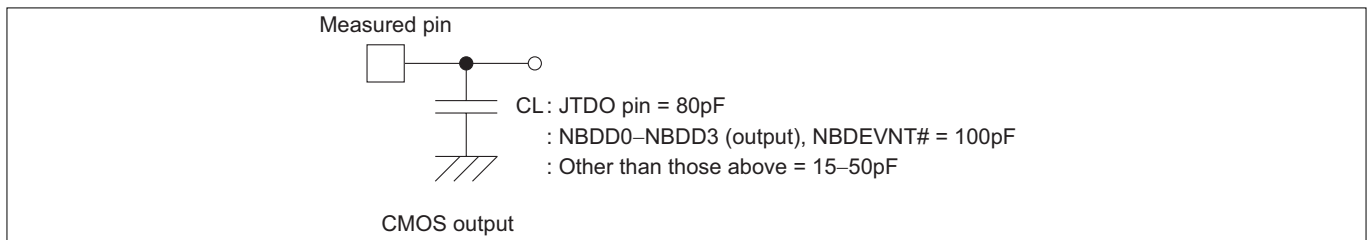


Figure 23.10.1 Output Switching Characteristics Measurement Circuit

#### (2) Input and Output Transition Time

	Symbol	Parameter	Rated Value		Unit	See Fig
			MIN	MAX		
Timing requirements	tr (INPUT)	High-going TransitionTime of Input	NBDCLK, NBDD0-NBDD3 pins (input), NBDSYNC# pin	8	ns	[115]
			JTCK, JTDI, JTMS	10	ns	
			JTRST pin	2	ms	
	tf (INPUT)	Low-ging Transition Time of Input	NBDCLK, NBDD0-NBDD3 pins (input), NBDSYNC# pin	8	ns	[116]
			JTCK, JTDI, JTMS	10	ns	
			JTRST pin	2	ms	



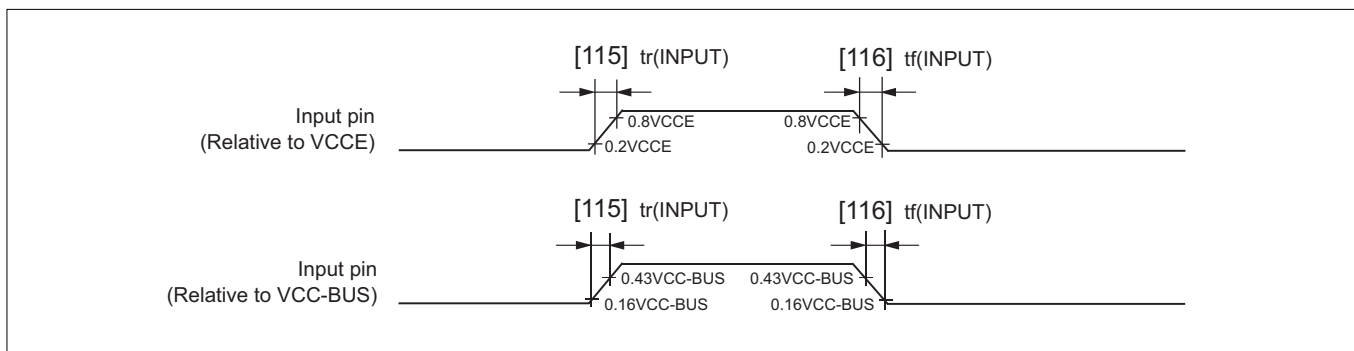


Figure 23.10.2 Input/Output Transition Time

### (3) Clock and Reset Timing

	Symbol	Parameter	Rated Value		Unit	See Fig 23.10.3
			MIN	MAX		
Timing requirements	tc(XIN)	Clock Input Cycle Time	50	66.7	ns	[119]
	tw(XINH)	External Clock Input "H" Pulse Width	20		ns	[120]
	tw(XINL)	External Clock Input "L" Pulse Width	20		ns	[121]
	tr(XINH)	External Clock Input High-going Time		5	ns	[122]
	tr(XINL)	External Clock Input Low-going Time		5	ns	[123]
	tw(RESET)	Reset Input "L" Pulse Width	300		ns	[124]

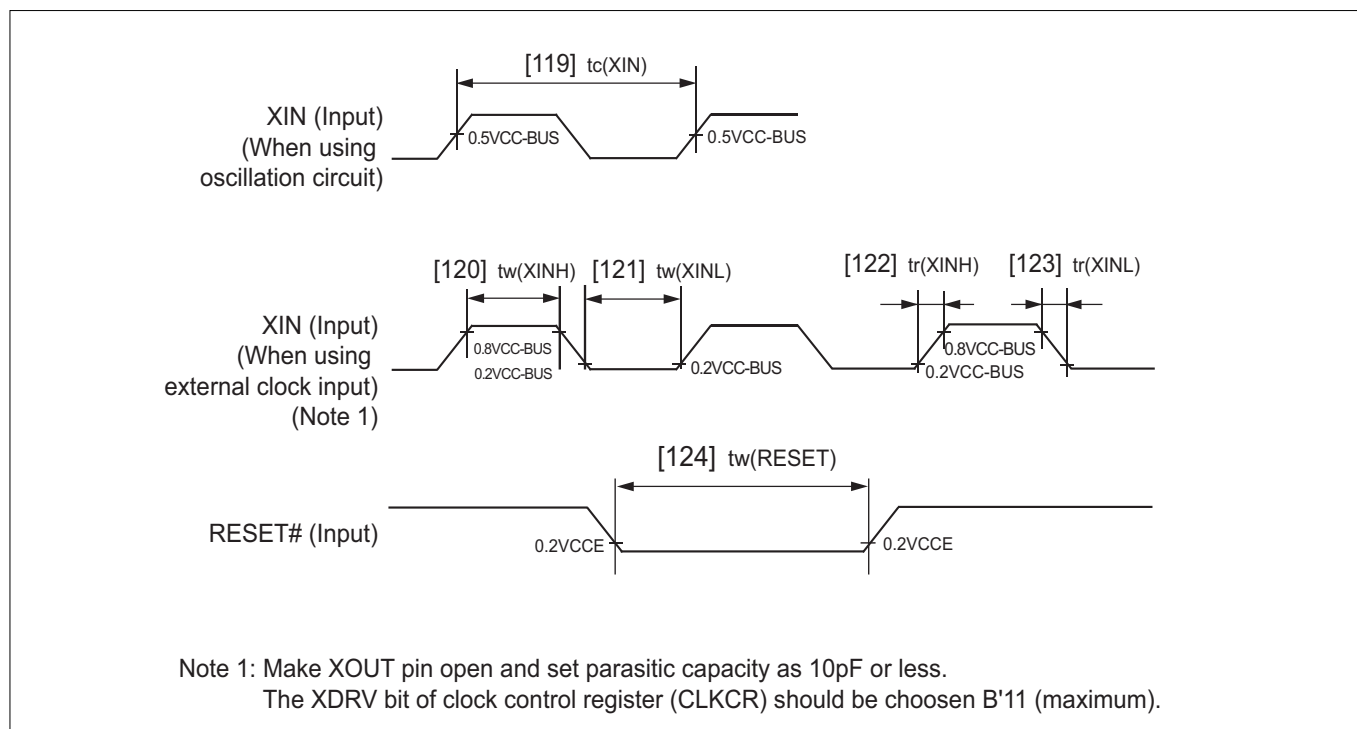


Figure 23.10.3 Clock and Reset Timing

#### (4) Input/output ports

	Symbol	Parameter	Rated Value		Unit	See Fig.
			MIN	MAX		
Timing requirements	tsu(P-E)	Port Input Setup Time	100		ns	[1]
	th(E-P)	Port Input Hold Time	0		ns	[2]
Switching characteristics	td(E-P)	Port Data Output Delay Time		100	ns	[3]

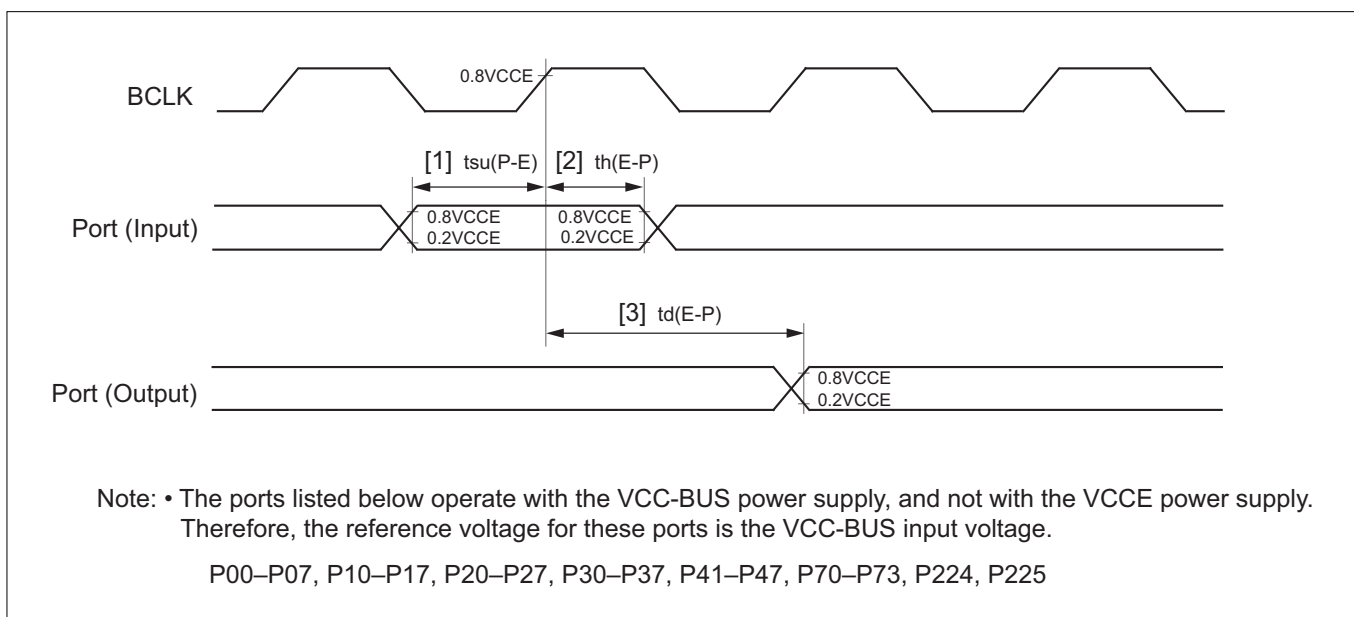


Figure 23.10.4 Input/Output Port Timing

#### (5) Serial interface

a) CSIO mode, with internal clock selected

	Symbol	Parameter	Rated Value		Unit	See Fig.
			MIN	MAX		
Timing requirements	tsu(D-CLK)	RXD Input Setup Time	When 3 point sampling is invalid	80	ns	[4]
			When 3 point sampling is valid	$80+t_c(\text{BCLK})$		
	th(CLK-D)	RXD Input Hold Time	$15+t_c(\text{BCLK})$	ns	[5]	
Switching characteristics	td(CLK-D)	TXD Output Delay Time		50	ns	[6]
	th(CLK-D)	TXD Hold Time	0		ns	[98]

b) CSIO mode, with external clock selected

	Symbol	Parameter	Rated Value		Unit	See Fig.
			MIN	MAX		
Timing requirements	tc(CLK)	CLK Input Cycle Time	$16 \times t_c(\text{BCLK})$		ns	[7]
	tw(CLKH)	CLK Input "H" Pulse Width	$5 \times t_c(\text{BCLK})$		ns	[8]
	tw(CLKL)	CLK Input "L" Pulse Width	$5 \times t_c(\text{BCLK})$		ns	[9]
	tsu(D-CLK)	RXD Input Setup Time	50		ns	[10]
	th(CLK-D)	RXD Input Hold Time	$55+t_c(\text{BCLK})$		ns	[11]
Switching characteristics	td(CLK-D)	TXD Output Delay Time	When 3 point sampling is invalid	$85+2t_c(\text{BCLK})$	ns	[12]
			When 3 point sampling is valid	$85+3t_c(\text{BCLK})$		

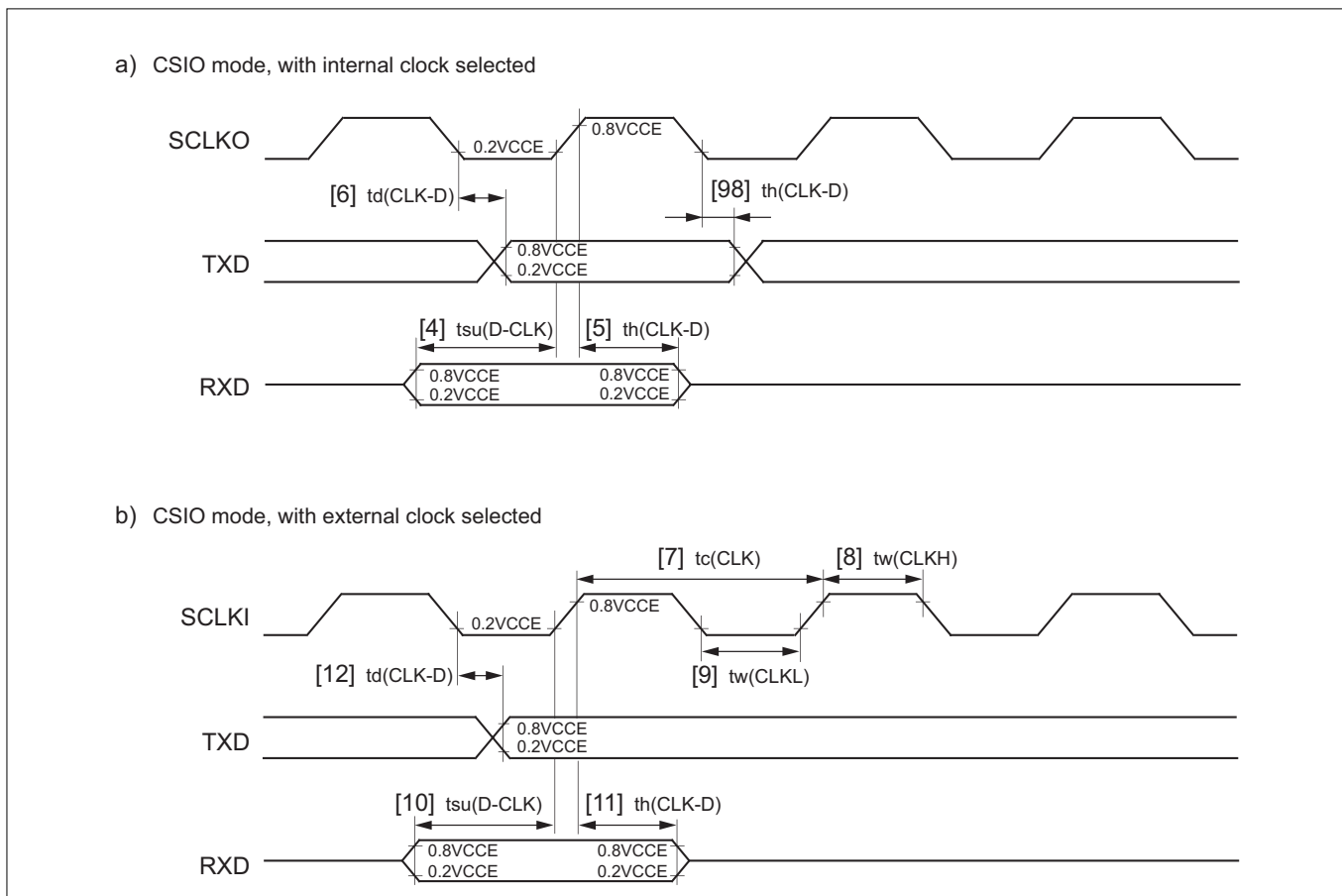


Figure 23.10.5 Serial Interface Timing

#### (6) SBI

	Symbol	Parameter	Rated Value		Unit	See Fig. 23.10.6
			MIN	MAX		
Timing requirements	tw(SBIL)	SBI# Input Pulse Width	$5 \times \frac{tc(BCLK)}{2}$		ns	[13]

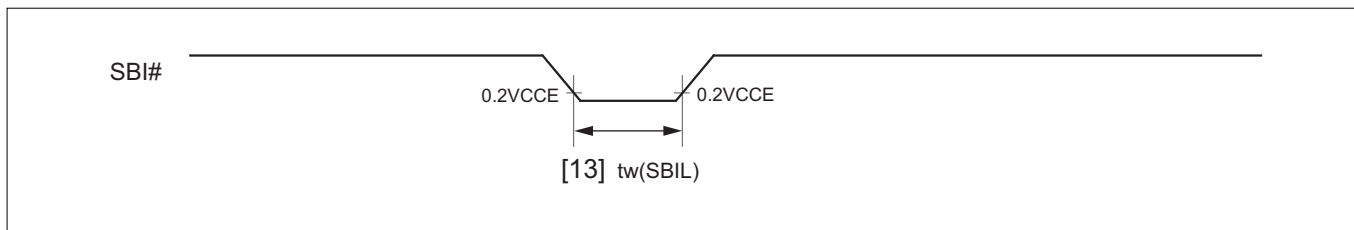


Figure 23.10.6 SBI Timing

#### (7) TIN

	Symbol	Parameter	Rated Value		Unit	See Fig. 23.10.7
			MIN	MAX		
Timing requirements	tw(TIN)	TIN Input Pulse Width	When BCLK/4 is selected (Note 1)	$7 \times tc(BCLK)$	ns	[14]
			When BCLK/4 is not selected (Note 1)	$7 \times tc \frac{tc(BCLK)}{2}$		

Note 1: TIN24, 25, PWMOFF0 are selected in TOU0 control register 1 (TOU0CR1) PRS3CKS bit, TIN26, 27, PWMOFF1 are selected in TOU1 control register 1 (TOU1CR1) PRS4CKS bit, other TIN are selected in common count clock select register (CNTCKSEL) PR012CKS bit.

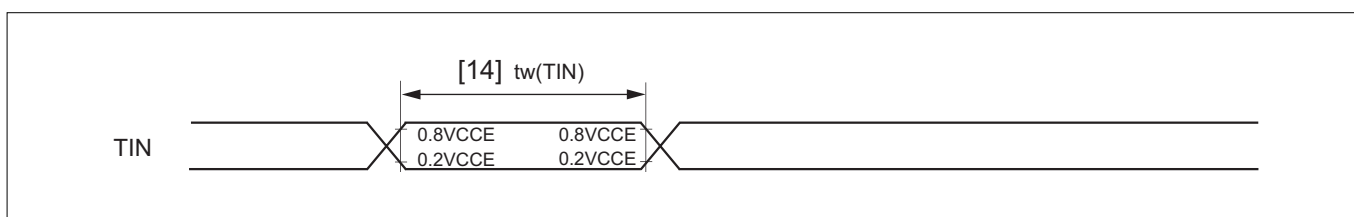


Figure 23.10.7 TIN Timing

#### (8) TO

	Symbol	Parameter	Rated Value		Unit	See Fig. 23.10.8
			MIN	MAX		
Switching characteristics	td(BCLK-TO)	TO Output Delay Time		100	ns	[15]

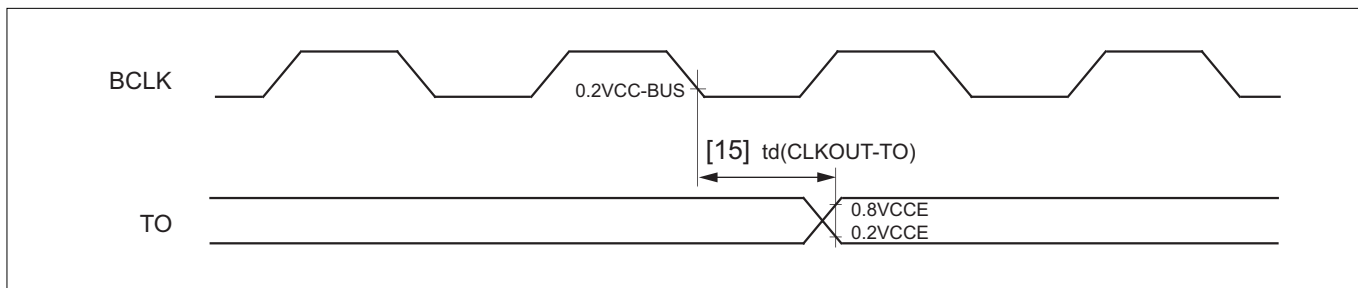


Figure 23.10.8 TO Timing

#### (9) TCLK

	Symbol	Parameter	Rated Value		Unit	See Fig. 23.10.9	
			MIN	MAX			
Timing requirements	tw(TCLKH)	TCLK Input "H" Pulse Width	When BCLK/4 is selected (Note 1)	$7 \times tc(\text{BCLK})$		ns	[99]
			When BCLK/2 is selected (Note 1)	$7 \times \frac{tc(\text{BCLK})}{2}$			
	tw(TCLKL)	TCLK Input "L" Pulse Width	When BCLK/4 is selected (Note 1)	$7 \times tc(\text{BCLK})$		ns	[100]
			When BCLK/2 is selected (Note 1)	$7 \times \frac{tc(\text{BCLK})}{2}$			

Note 1: Selected in common count clock select register (CNTCKSEL) PRS012CKS bit.

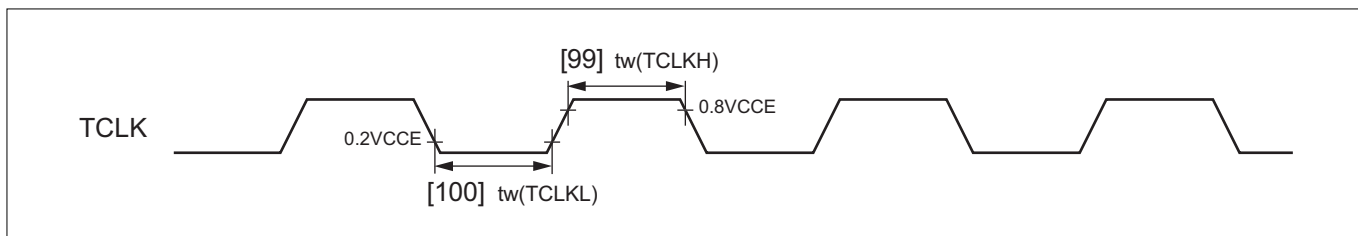
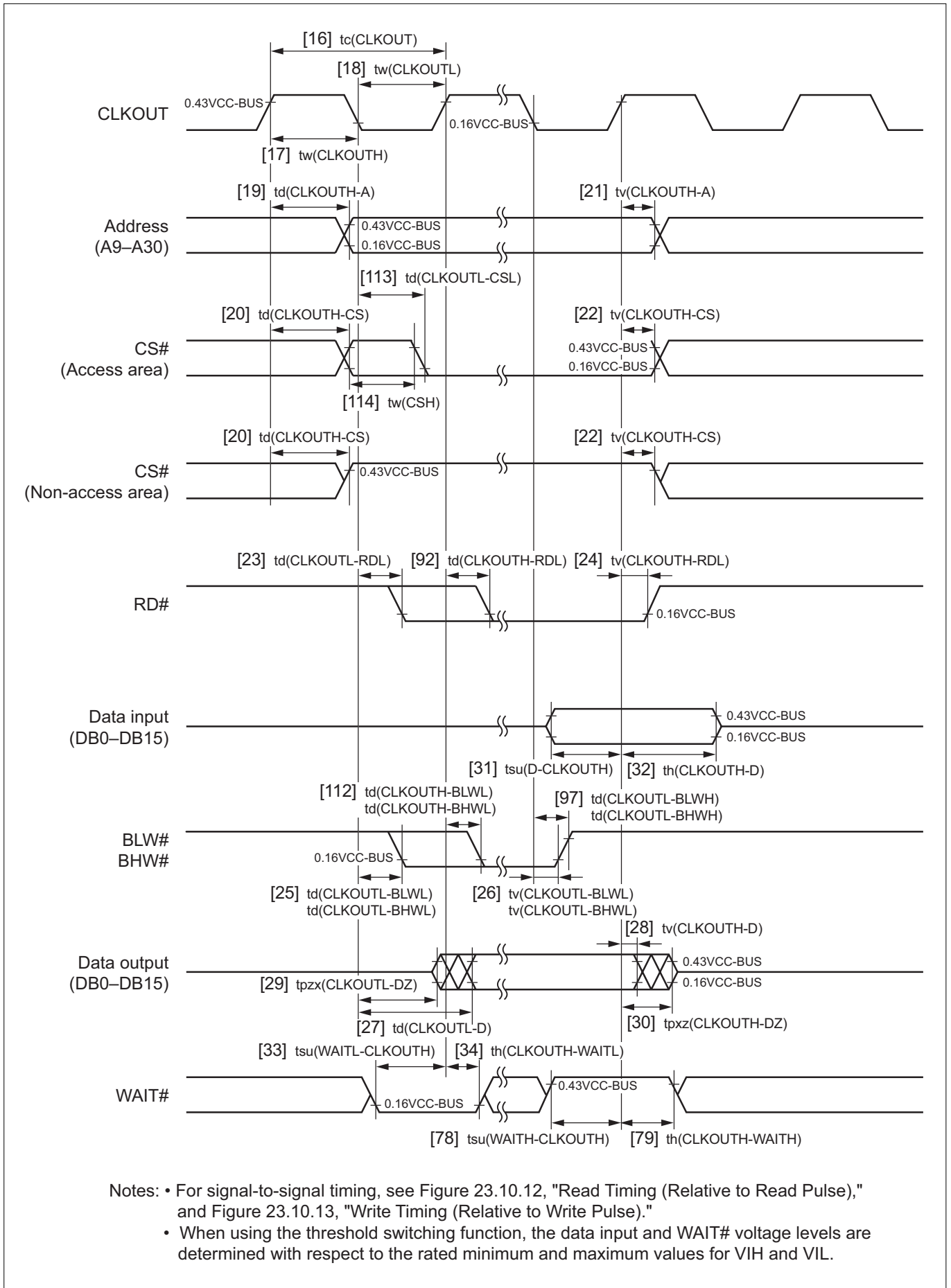


Figure 23.10.9 TCLK Timing

## (10) Read and write timing (1/4)

	Symbol	Parameter	Rated Value		Unit	See Figs. 23.10.10 23.10.11
			MIN	MAX		
Timing requirements	tsu(D-CLKOUTH)	Data Input Setup Time before CLKOUT	26		ns	[31]
	th(CLKOUTH-D)	Data Input Hold Time after CLKOUT	0		ns	[32]
	tsu(WAITL-CLKOUTH)	WAIT# Input Setup Time before CLKOUT	26		ns	[33]
	th(CLKOUTH-WAITL)	WAIT# Input Hold Time after CLKOUT	0		ns	[34]
	tsu(WAITH-CLKOUTH)	WAIT# Input Setup Time before CLKOUT	26		ns	[78]
	th(CLKOUTH-WAITH)	WAIT# Input Hold Time after CLKOUT	0		ns	[79]
Switching characteristics	tv(CLKOUTH-BLWL) tv(CLKOUTH-BHWL)	Write Valid Time after CLKOUT (with zero wait state)	-5		ns	[90]
	td(CLKOUTH-RDL)	Read Delay Time after CLKOUT (when either SWAIT or CWAIT = 1)		17	ns	[92]
	td(CLKOUTH-BLWL) td(CLKOUTH-BHWL)	Write Delay Time after CLKOUT (byte write mode) (when either SWAIT or CWAIT = 1)		17	ns	[112]
	td(CLKOUTL-BLWH) td(CLKOUTL-BHWH)	Write Delay Time after CLKOUT		14	ns	[97]
	tc(CLKOUT)	CLKOUT Output Cycle Time		$\frac{tc(XIN)}{2}$	ns	[16]
	tw(CLKOUTH)	CLKOUT Output "H" Pulse Width	$\frac{tc(CLKOUT)}{2} - 5$		ns	[17]
	tw(CLKOUTL)	CLKOUT Output "L" Pulse Width	$\frac{tc(CLKOUT)}{2} - 5$		ns	[18]
	td(CLKOUTH-A)	Address Delay Time after CLKOUT		29	ns	[19]
	td(CLKOUTH-CS)	Chip Select Delay Time after CLKOUT (When CWAIT=0)		30	ns	[20]
	td(CLKOUTL-CSL)	Chip Select Delay Time after CLKOUT (When CWAIT=1)		30	ns	[113]
	tv(CLKOUTH-A)	Address Valid Time after CLKOUT	-5		ns	[21]
	tv(CLKOUTH-CS)	Chip Select Valid Time after CLKOUT	-5		ns	[22]
	td(CLKOUTL-RDL)	Read Delay Time after CLKOUT (When both SWAIT and CWAIT=0 or both SWAIT and CWAIT=1)		14	ns	[23]
	tv(CLKOUTH-RDL)	Read Valid Time after CLKOUT	-5		ns	[24]
	td(CLKOUTL-BLWL) td(CLKOUTL-BHWL)	Write Delay Time after CLKOUT (When both SWAIT and CWAIT=0 or both SWAIT and CWAIT=1)		14	ns	[25]
	tv(CLKOUTL-BLWL) tv(CLKOUTL-BHWL)	Write Valid Time after CLKOUT	-5		ns	[26]
	td(CLKOUTL-D)	Data Output Delay Time after CLKOUT		0 wait state: 14 1-plus wait states: 19	ns	[27]
	tv(CLKOUTH-D)	Data Output Valid Time after CLKOUT	0 wait state: -4 1-plus wait states: -10		ns	[28]
	tpzx(CLKOUTL-DZ)	Data Output Enable Time after CLKOUT	-10		ns	[29]
	tpxz(CLKOUTH-DZ)	Data Output Disable Time after CLKOUT		5	ns	[30]
tw(CSH)	Chip Select "H" Pulse Width	C=0: tc(CLKOUT)xID-(15ID) C=1: tc(CLKOUT) ( $\frac{1}{2}$ +ID) -15		ns	[114]	



**Figure 23.10.10 Read and Write Timing (Relative to CLKOUT) with 1 or More Wait States**

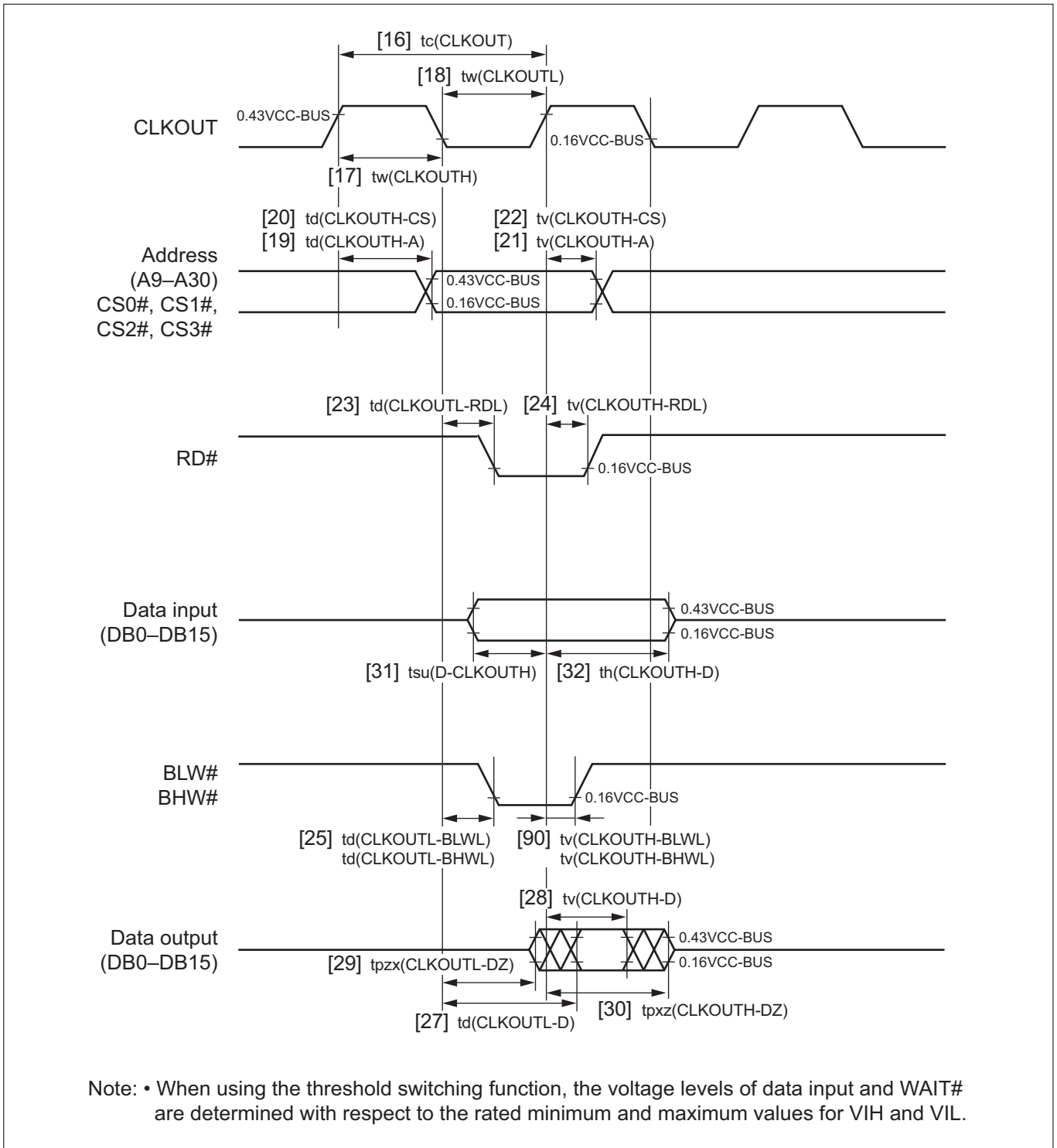


Figure 23.10.11 Read and Write Timing (Relative to CLKOUT) with Zero Wait State



#### (11) Read and write timing (2/4)

	Symbol	Parameter	Rated Value		Unit	See Figs. 23.10.12 23.10.13
			MIN	MAX		
Timing requirements	tsu(D-RDH)	Data Input Setup Time before Read	30		ns	[44]
	th(RDH-D)	Data Input Hold Time after Read	0		ns	[45]
	tsu(WAITH-RDL) tsu(WAITL-RDL)	Data Input Setup Time before Read	tc(CLKOUT) + 21		ns	[132]
	tw(WAITH)	Wait "H" Pulse Width (Note 1)	26		ns	[133]
	tw(WAITL)	Wait "L" Pulse Width (Note 1)	26		ns	[134]
	tsu(WAITH-BLWL) tsu(WAITH-BHWL) tsu(WAITL-BLWL) tsu(WAITL-BHWL)	Wait Input Setup Time before Write (byte write mode)	$\frac{tc(CLKOUT)}{2} + 21$		ns	[135]
Switching characteristics	tw(RDH)	Read "H" Pulse Width	$\frac{tc(CLKOUT)}{2} (1+C+S) - 5$		ns	[55]
	tw(RDL)	Read "L" Pulse Width	$\frac{tc(CLKOUT)}{2} (1+2W-C-S) - 20$		ns	[43]
	tw(BLWL) tw(BHWL)	Write "L" Pulse Width (byte write mode)	0 wait state: $\frac{tc(CLKOUT)}{2} - 11$ 1-plus wait states: $\frac{tc(CLKOUT)}{2} (2W-C-S) - 20$		ns	[51]
	td(RDH-BLWL) td(RDH-BHWL)	Write Delay Time after Read	$tc(CLKOUT) (\frac{1+C+S}{2} + R + ID) - 10$		ns	[56]
	td(BLWH-RDL) td(BHWH-RDL)	Read Delay Time after Write	0 wait state: $\frac{tc(CLKOUT)}{2} - 10$ 1-plus wait states: $tc(CLKOUT) (1 + R + \frac{C+S}{2}) - 10$		ns	[57]
	td(CSL-RDL)	Chip Select Delay Time before Read	$\frac{tc(CLKOUT)}{2} (1+S) - 16$		ns	[93]
	td(CSL-BLWL) td(CSL-BHWL)	Chip Select Delay Time before Write	$\frac{tc(CLKOUT)}{2} (1+S) - 16$		ns	[95]
	td(A-RDL)	Address Delay Time before Read	$\frac{tc(CLKOUT)}{2} (1+C+S) - 15$		ns	[39]
	td(CS-RDL)	Chip Select Delay Time before Read	$\frac{tc(CLKOUT)}{2} (1+S) - 15$		ns	[40]
	tv(RDH-A)	Address Valid Time after Read	tc(CLKOUT) x (R+ID)		ns	[41]
	tv(RDH-CS)	Chip Select Valid Time after Read	tc(CLKOUT) x R		ns	[42]
	tpzx(RDH-DZ)	Data Output Enable Time after Read	tc(CLKOUT) ( $\frac{1}{2}$ + R + ID)		ns	[46]
	td(A-BLWL) td(A-BHWL)	Address Delay Time before Write (byte write mode)	$\frac{tc(CLKOUT)}{2} (1+C+S) - 15$		ns	[47]
	td(CS-BLWL) td(CS-BHWL)	Chip Select Delay Time before Write (byte write mode)	$\frac{tc(CLKOUT)}{2} (1+S) - 15$		ns	[48]
	tv(BLWH-A) tv(BHWH-A)	Address Valid Time after Write (byte write mode)	0 wait state: -5 1-plus wait states: $tc(CLKOUT) (\frac{1}{2} + R) - 5$		ns	[49]
	tv(BLWH-CS) tv(BHWH-CS)	Chip Select Valid Time after Write (byte write mode)	0 wait state: -5 1-plus wait states: $tc(CLKOUT) (\frac{1}{2} + R) - 5$		ns	[50]
	td(BLWL-D) td(BHWL-D)	Data Output Delay Time after Write (byte write mode)		0 wait state: 5 1-plus wait states: $15 - \frac{tc(CLKOUT)}{2} x (S+C)$	ns	[52]

Note 1: Hold a level during tw(WAITH), tw(WAITL) from the position of the minimum value of tsu(WAITH-RDL), tsu(WAITL-RDL), tsu(WAITH-BLWL), tsu(WAITH-BHWL), tsu(WAITL-BLWL), and tsu(WAITL-BHWL).

	Symbol	Parameter	Rated Value		Unit	See Figs. 23.10.12 23.10.13
			MIN	MAX		
Switching characteristics	tv(BLWH-D) tv(BHWH-D)	Data Output Valid Time after Write (byte write mode)	0 wait state: -7 1-plus wait states: $tc(CLKOUT)(\frac{1}{2} + R) - 13$		ns	[53]
	tpzx(BLWL-DZ) tpzx(BHWL-DZ)	Data Output Enable Time after Write (byte write mode)	0 wait state: -20 1-plus wait states: $-22 - \frac{tc(CLKOUT)}{2} (S+C)$		ns	[126]
	tpxz(BLWH-DZ) tpxz(BHWH-DZ)	Data Output Disable Time after Write (byte write mode)		0 wait state: 5 1-plus wait states: $tc(CLKOUT)(\frac{1}{2} + R) + 5$		ns

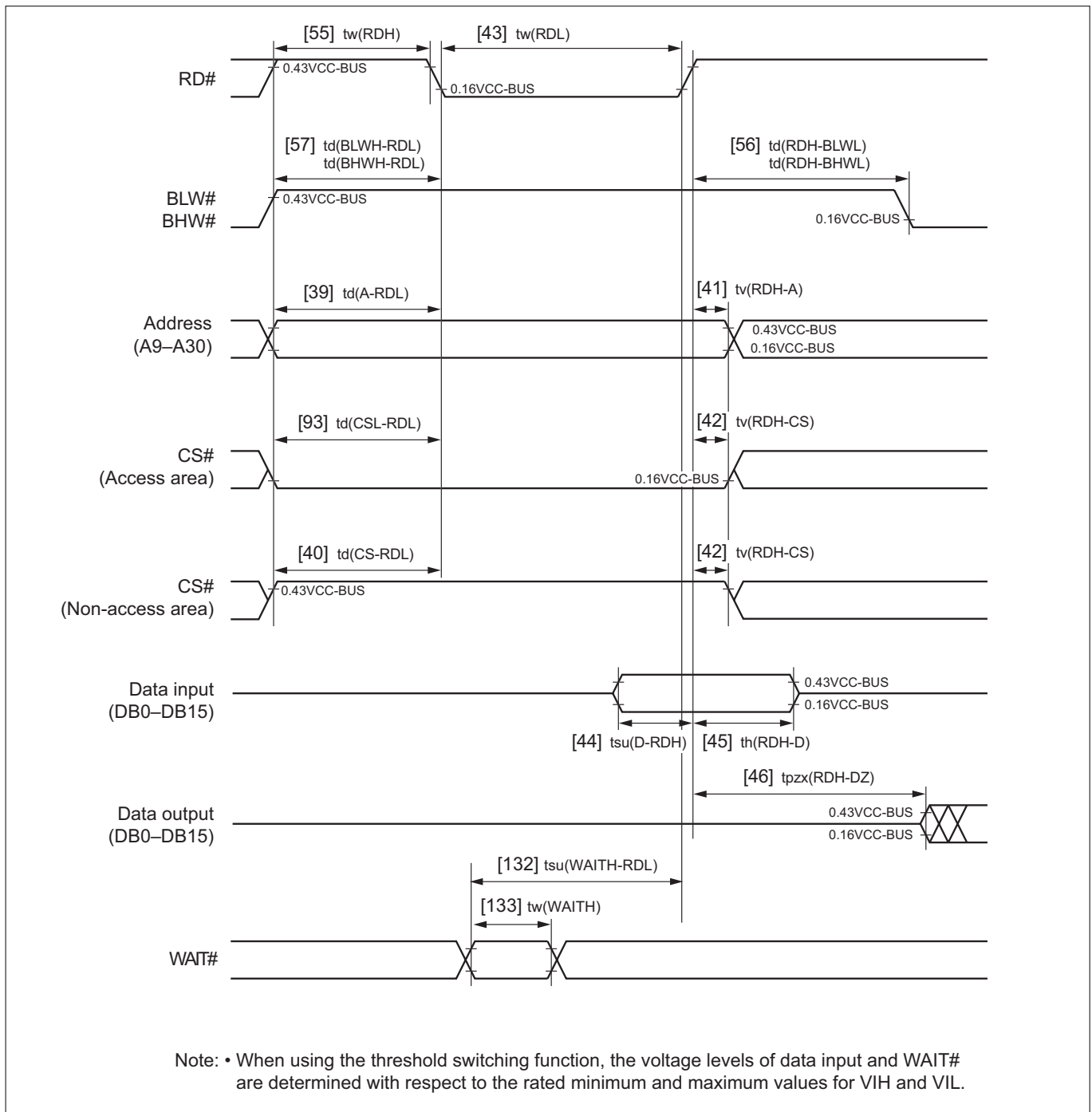


Figure 23.10.12 Read Timing (Relative to Read Pulse)

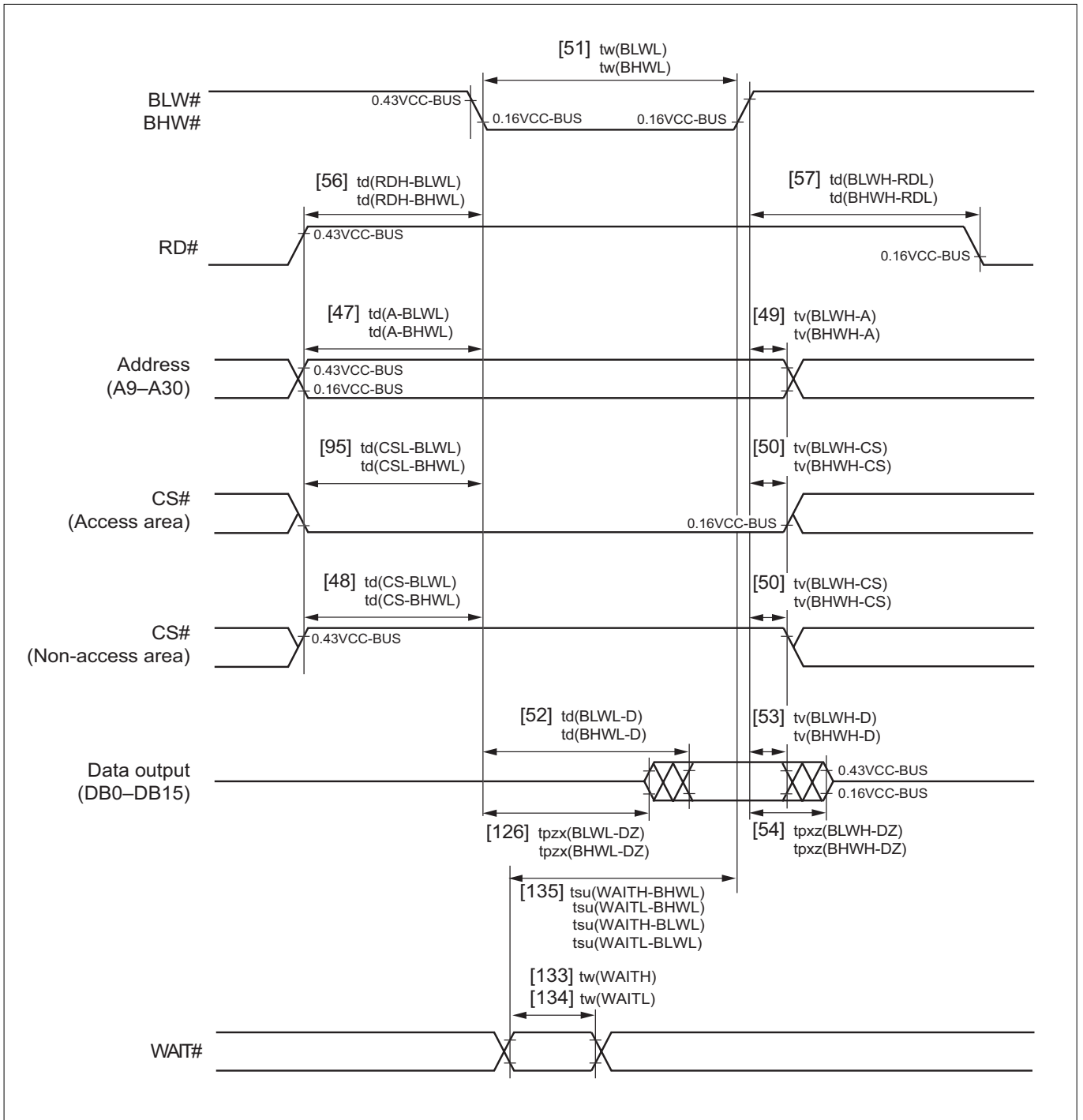


Figure 23.10.13 Write Timing (Relative to Write Pulse)

## (12) Read and write timing (3/4)

	Symbol	Parameter	Rated Value		Unit	See Figs. 23.10.14
			MIN	MAX		
Timing requirements	tsu(D-RDH)	Data Input Setup Time before Read	30		ns	[44]
	th(RDH-D)	Data Input Hold Time after Read	0		ns	[45]
Switching characteristics	td(A-RDL)	Address Delay Time before Read	$\frac{tc(\text{CLKOUT})}{2} (1+C+S)-15$		ns	[39]
	td(CS-RDL)	Chip Select Delay Time before Read	$\frac{tc(\text{CLKOUT})}{2} (1+S) - 15$		ns	[40]
	tv(RDH-A)	Address Valid Time after Read	$tc(\text{CLKOUT})(R+ID)$		ns	[41]
	tv(RDH-CS)	Chip Select Valid Time after Read	$tc(\text{CLKOUT}) \times R$		ns	[42]
	tw(RDL)	Read "L" Pulse Width	$\frac{tc(\text{CLKOUT})}{2} (1+2W-C-S)-20$		ns	[43]
	tpzx(RDH-DZ)	Data Output Enable Time after Read	$tc(\text{CLKOUT})(\frac{1}{2} + R+ID)$		ns	[46]
	td(RDH-WRL)	Write Delay time after Read (byte write mode)	$tc(\text{CLKOUT})(\frac{1+C+S}{2}+R+ID)-10$		ns	[80]
	td(WRH-RDL)	Read Delay time after Write (byte write mode)	During 0 wait: $\frac{tc(\text{CLKOUT})}{2} -20$ During 1 wait: $tc(\text{CLKOUT})(1+R+\frac{C+S}{2}) -20$		ns	[81]
	td(CSL-RDL)	Chip select Delay time before Read	$\frac{tc(\text{CLKOUT})}{2} (1+S)-16$		ns	[93]
	td(BLEL-RDL) td(BHEL-RDL)	Byte Enable Delay Time before Read (byte write mode)	$\frac{tc(\text{CLKOUT})}{2} \times (1+S)-20$		ns	[136]
tv(RDH-BLEL) tv(RDH-BHEL)	Valid Time after Read (byte write mode)	$tc(\text{CLKOUT}) \times R-5$		ns	[137]	

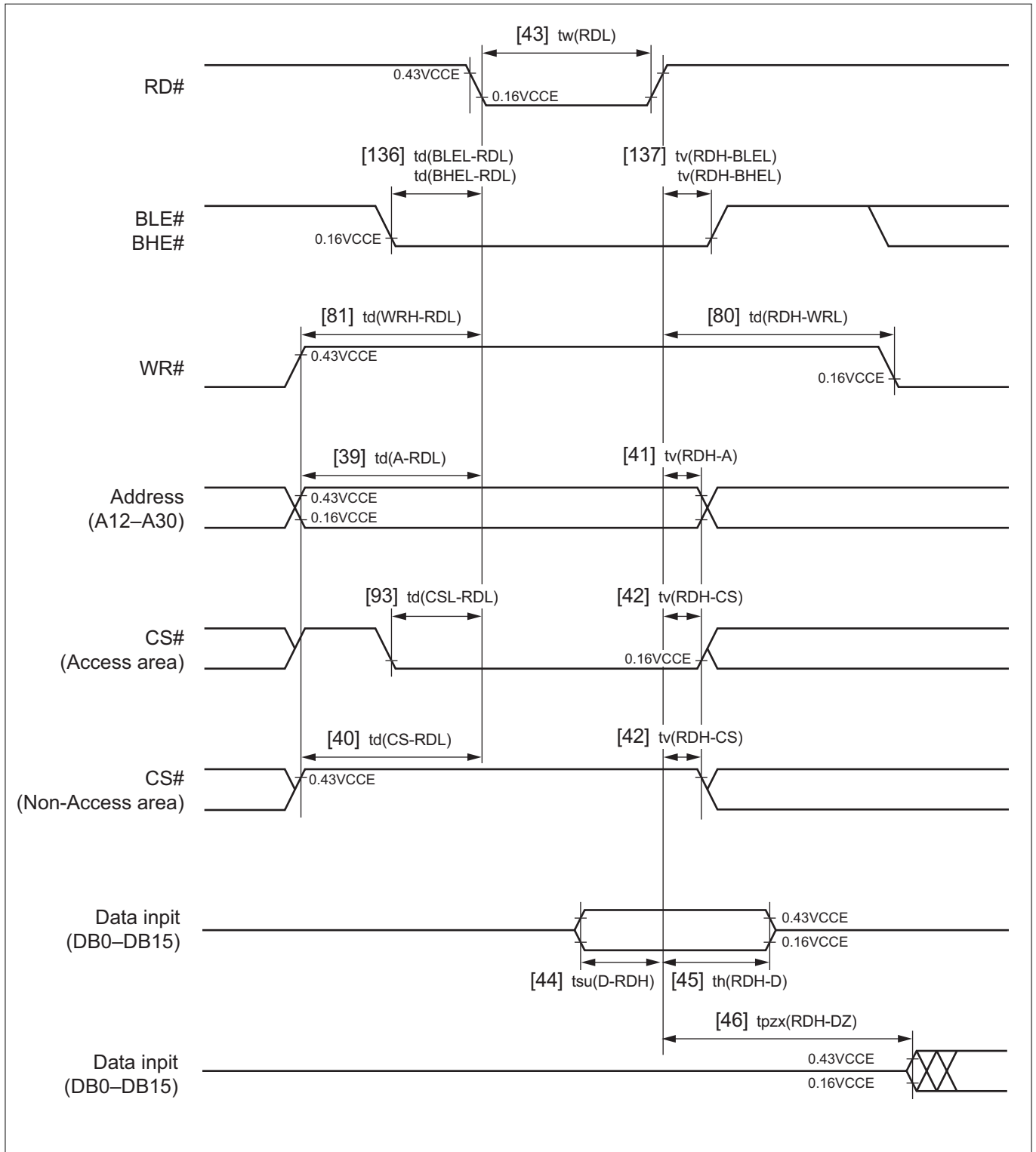


Figure 23.10.14 Read Timing (Byte Enable Mode)

## (13) Read and write timing (4/4)

	Symbol	Parameter	Rated Value		Unit	See Fig. 23.10.15
			MIN	MAX		
Switching characteristics	tw(WRL)	Write "L" Pulse Width (byte enable mode)	0 wait state: $\frac{tc(\text{CLKOUT})}{2} - 7$ 1-plus wait states: $\frac{tc(\text{CLKOUT})}{2} (2W-C-S)-20$		ns	[68]
	td(RDH-WRL)	Write Delay Time after Read (byte enable mode)	$tc(\text{CLKOUT}) \left( \frac{1+C+S}{2} + R + D \right) - 10$		ns	[80]
	td(WRH-RDL)	Read Delay Time after Write (byte enable mode)	0 wait state: $\left( \frac{tc(\text{CLKOUT})}{2} \right) - 20$ 1-plus wait states: $tc(\text{CLKOUT}) \left( 1 + R + \frac{C+S}{2} \right) - 20$		ns	[81]
	td(CSL-WRL)	Chip Select Delay Time before Write (byte enable mode)	$\frac{tc(\text{CLKOUT})}{2} (1+S) - 20$		ns	[96]
	td(A-WRL)	Address Delay Time before Write (byte enable mode)	$\frac{tc(\text{CLKOUT})}{2} (1+C+S) - 20$		ns	[69]
	td(CS-WRL)	Chip Select Delay Time before Write (byte enable mode)	$\frac{tc(\text{CLKOUT})}{2} (1+S) - 15$		ns	[70]
	tv(WRH-A)	Address Valid Time after Write (byte enable mode)	0 wait state: -5 1-plus wait states: $tc(\text{CLKOUT}) \left( \frac{1}{2} + R \right) - 5$		ns	[71]
	tv(WRH-CS)	Chip Select Valid Time after Write (byte enable mode)	0 wait state: -5 1-plus wait states: $tc(\text{CLKOUT}) \left( \frac{1}{2} + R \right) - 5$		ns	[72]
	td(BLEL-WRL) td(BHEL-WRL)	Byte Enable Delay Time before Write (byte enable mode)	$\frac{tc(\text{CLKOUT})}{2} (1+S) - 15$		ns	[73]
	tv(WRH-BLEL) tv(WRH-BHEL)	Byte Enable Valid Time after Write (byte enable mode)	0 wait state: -5 1-plus wait states: $tc(\text{CLKOUT}) \left( \frac{1}{2} + R \right) - 5$		ns	[74]
	td(WRL-D)	Data Output Delay Time after Write (byte enable mode)		0 wait state: 9 1-plus wait states: $15 - \frac{tc(\text{CLKOUT})}{2} (S+C)$	ns	[75]
	tv(WRH-D)	Data Output Valid Time after Write (byte enable mode)	0 wait state : -7 1-plus wait states: $tc(\text{CLKOUT}) \left( \frac{1}{2} + R \right) - 13$		ns	[76]
	tpzx(WRH-DZ)	Data Output Enable Time after Write (byte enable mode)	0 wait state: -20 1-plus wait states: $-22 - \frac{tc(\text{CLKOUT})}{2} (S+C)$		ns	[127]
	tpxz(WRH-DZ)	Data Output Disable Time after Write (byte enable mode)		0 wait state: 5 1-plus wait states: $tc(\text{CLKOUT}) \left( \frac{1}{2} + R \right) + 5$	ns	[77]

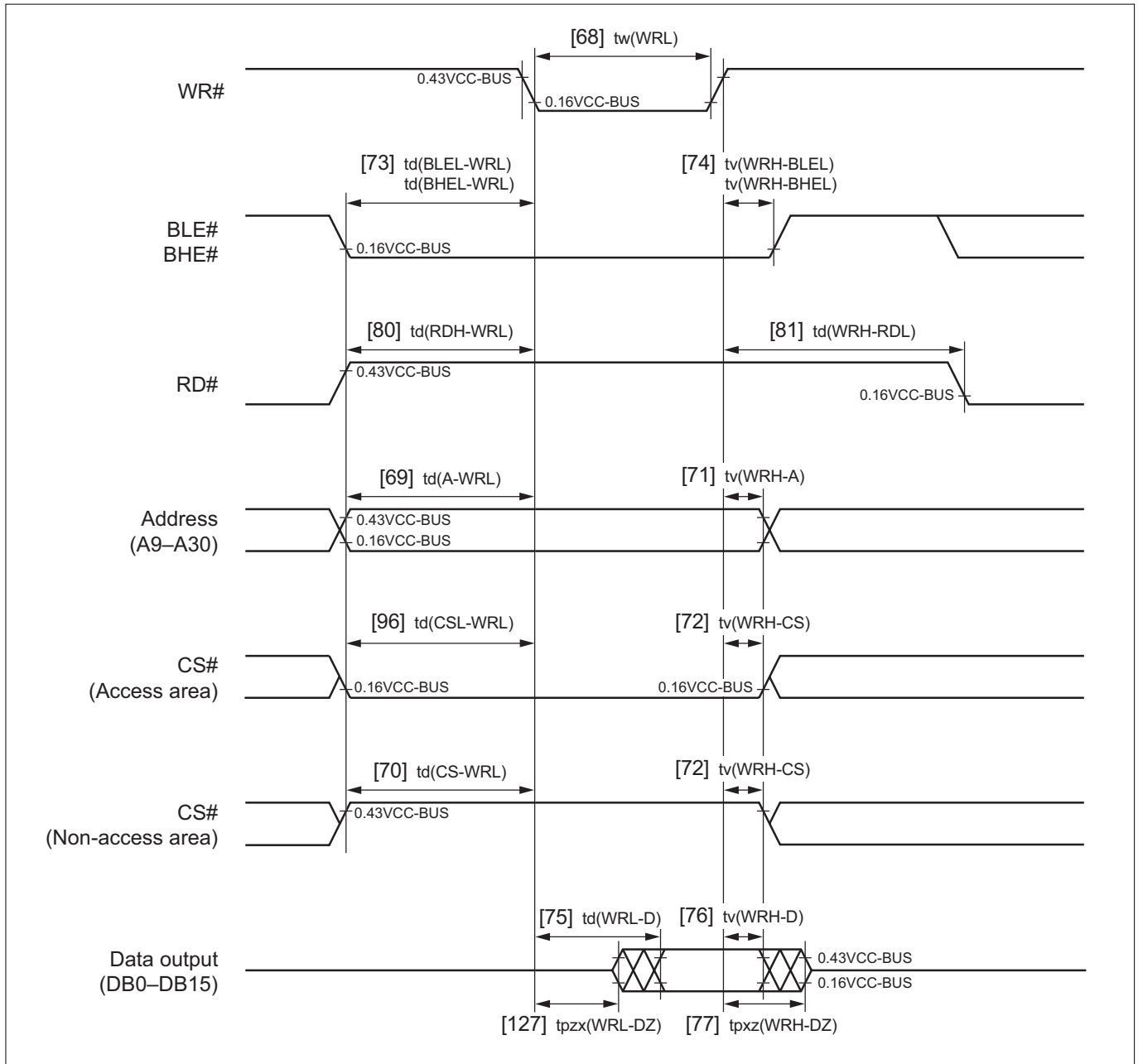


Figure 23.10.15 Write Timing (Byte Enable mode)

#### (14) Bus arbitration timing

	Symbol	Parameter	Rated Value		Unit	See Fig.
			MIN	MAX		
Timing requirements	tsu(HREQ#-CLKOUTH)	HREQ# Input Setup Time before CLKOUTH	27		ns	[35]
	th(CLKOUTH-HREQ#)	HREQ# Input Hold Time after CLKOUTH	0		ns	[36]
Switching characteristics	td(CLKOUTL-HACKL)	HACK# Delay Time after CLKOUTH		29	ns	[37]
	tv(CLKOUTL-HACKL)	HACK# Valid Time after CLKOUTH	-11		ns	[38]

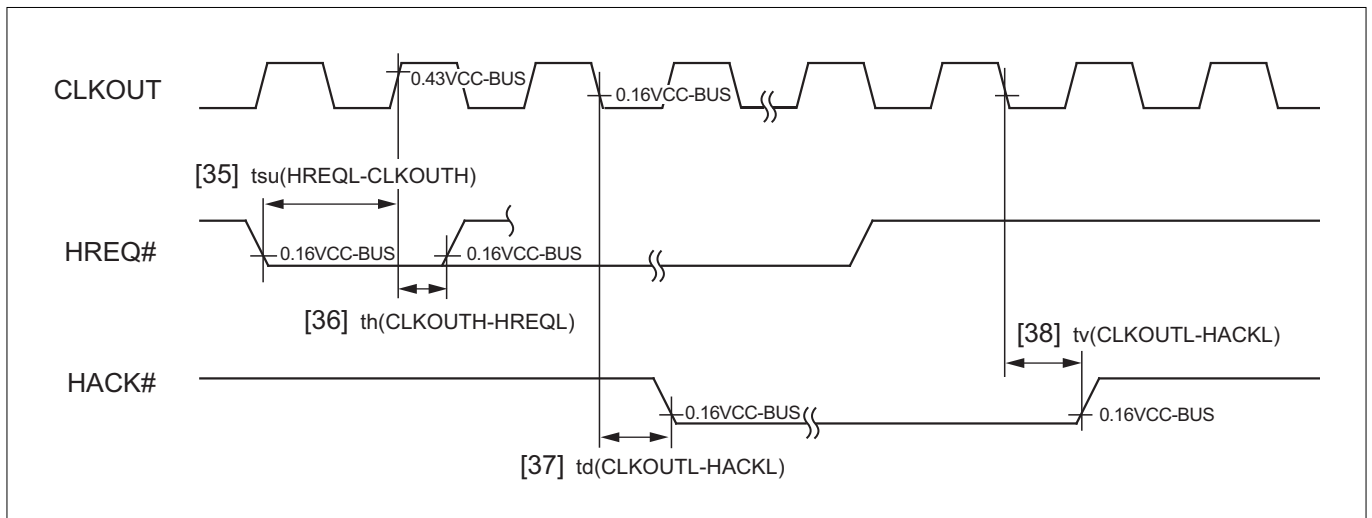


Figure 23.10.16 Bus Arbitration Timing



#### (15) JTAG interface timing

	Symbol	Parameter	Measurement condition	Rated Value		Unit	See Fig. 23.10.17
				MIN	MAX		
Timing requirements	tc(JTCK)	JTCK Input Cycle Time		100		ns	[60]
	tw(JTCKH)	JTCK Input "H" Pulse Width		40		ns	[61]
	tw(JTCKL)	JTCK Input "L" Pulse Width		40		ns	[62]
	tsu(JTDI-JTCK)	JTDI, JTMS Input Setup Time		15		ns	[63]
	th(JTCK-JTDI)	JTDI, JTMS Input Hold Time		20		ns	[64]
	tw(JTRST)	JTRST Input "L" Pulse Width		tc(JTCK)		ns	[67]
Switching characteristics	td(JTCK-JTDO)	JTDO Output Delay Time after JTCK	CL=80pF		40	ns	[65]
	tpzx(JTCK-JTDOZ)	JTDO Output Enable Time after JTCK	CL=80pF	5		ns	[128]
	tpxz(JTCK-JTDOZ)	JTDO Output Disable Time after JTCK	CL=80pF		40	ns	[66]
	tv(JTCK-JTDO)	TDO Output Valid Time after JTCK	CL=80pF	5		ns	[129]

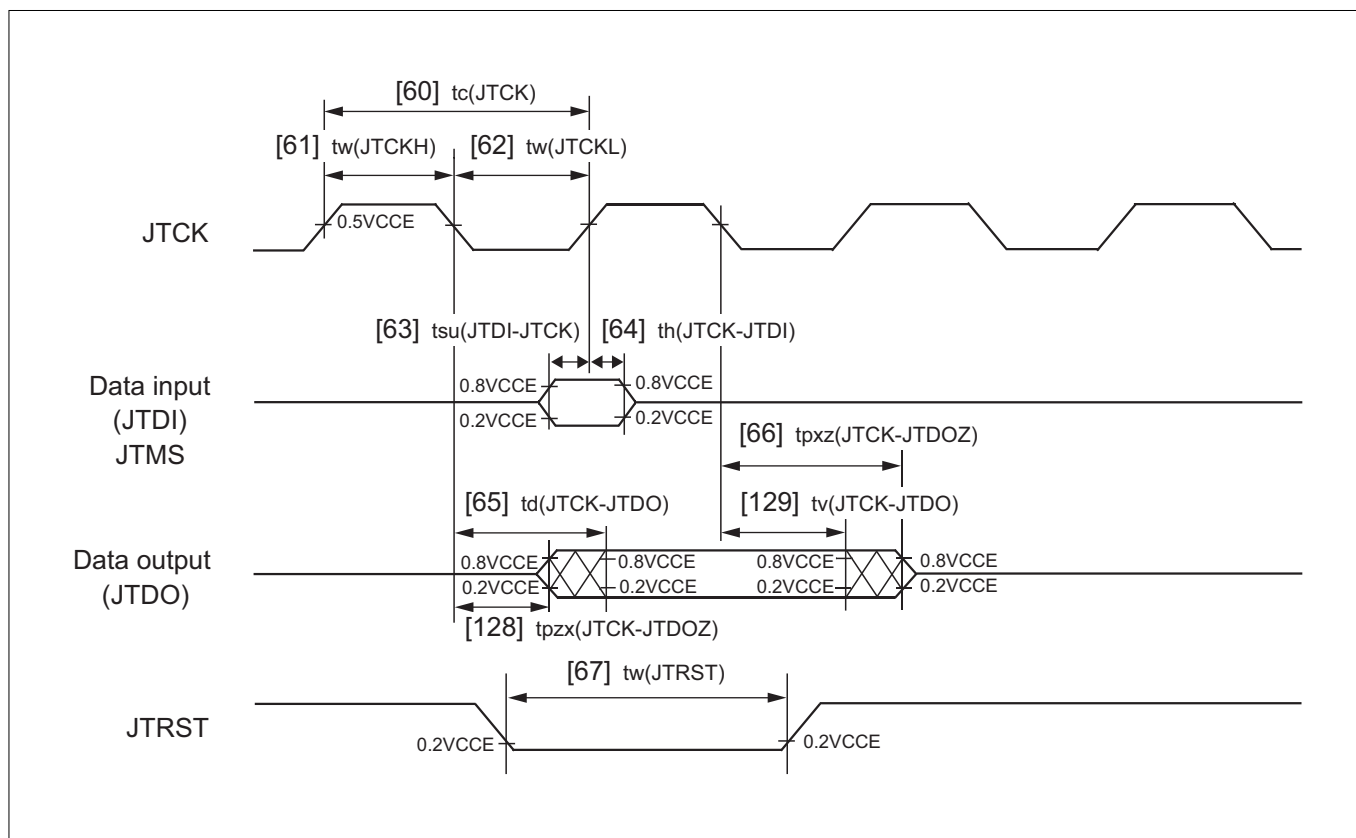


Figure 23.10.17 JTAG Interface Timing

#### (16) RTD timing

	Symbol	Parameter	Rated Value		Unit	See Fig. 23.10.18
			MIN	MAX		
Timing requirements	$t_c(\text{RTDCLK})$	RTDCLK Input Cycle Time	500		ns	[82]
	$t_w(\text{RTDCLKH})$	RTDCLK Input "H" Pulse Width	230		ns	[83]
	$t_w(\text{RTDCLKL})$	RTDCLK Input "L" Pulse Width	230		ns	[84]
	$t_h(\text{RTDCLKH-RTDRXD})$	RTDRXD Input Hold Time	50		ns	[88]
	$t_{su}(\text{RTDRXD-RTDCLKL})$	RTDRXD Input Setup Time	60		ns	[89]
Switching characteristics	$t_d(\text{RTDCLKH-RTDACK})$	RTDACK Delay Time after RTDCLK Input		160	ns	[85]
	$t_v(\text{RTDCLKL-RTDACK})$	RTDACK Valid Time after RTDCLK Input		160	ns	[86]
	$t_d(\text{RTDCLKH-RTDTXD})$	RTDTXD Delay Time after RTDCLK Input		160	ns	[87]

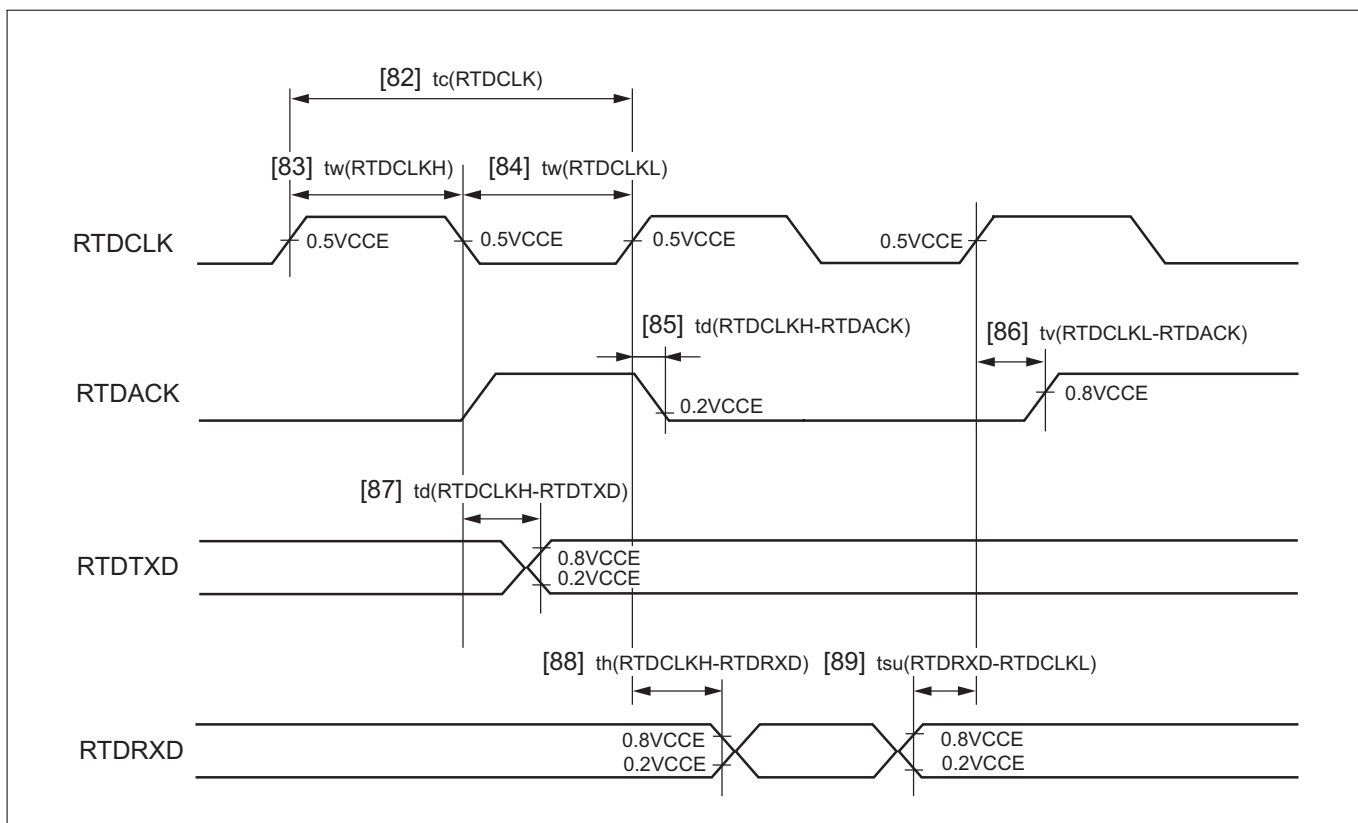


Figure 23.10.18 RTD Timing

#### (17) NBD timing

	Symbol	Parameter	Measurement Condition	Rated Value		Unit	See Fig. 23.10.19
				MIN	MAX		
Timing requirements	tc(NBDCLK)	NBDCLK Input Cycle Time		100		ns	[103]
	tw(NBDCLKL)	NBDCLK Input "L" Pulse Width		45		ns	[104]
	tsu(NBDD-NBDCLKH)	NBDD Input Setup Time before NBDCLK		20		ns	[107]
	th(NBDCLKH-NBDD)	NBDD Input Hold Time after NBDCLK		5		ns	[108]
	tsu(NBDSYNCL-NBDCLKH)	NBDSYNC# Input Setup Time before NBDCLK		20		ns	[109]
	th(NBDCLKH-NBDSYNCL)	NBDSYNC# Input Hold Time after NBDCLK	CL=100pF	5		ns	[110]
Switching characteristics	td(NBDCLKH-NBDD)	NBDD Output Delay Time after NBDCLK	CL=100pF	7	tc(NBDCLK)-20	ns	[105]
	tpzx(NBDCLKH-NBDDZ)	NBDD Output Enable Time after NBDCLK	CL=100pF	5		ns	[130]
	tv(NBDCLKH-NBDD)	NBDD Output Valid Time after NBDCLK	CL=100pF	5		ns	[106]
	tpxz(NBDCLKH-NBDDZ)	NBDD Output Disable Time after NBDCLK	CL=100pF		60	ns	[131]
	tw(NBDEVNTL)	NBDEVNT# Output "L" Pulse Width	CL=100pF	30		ns	[111]

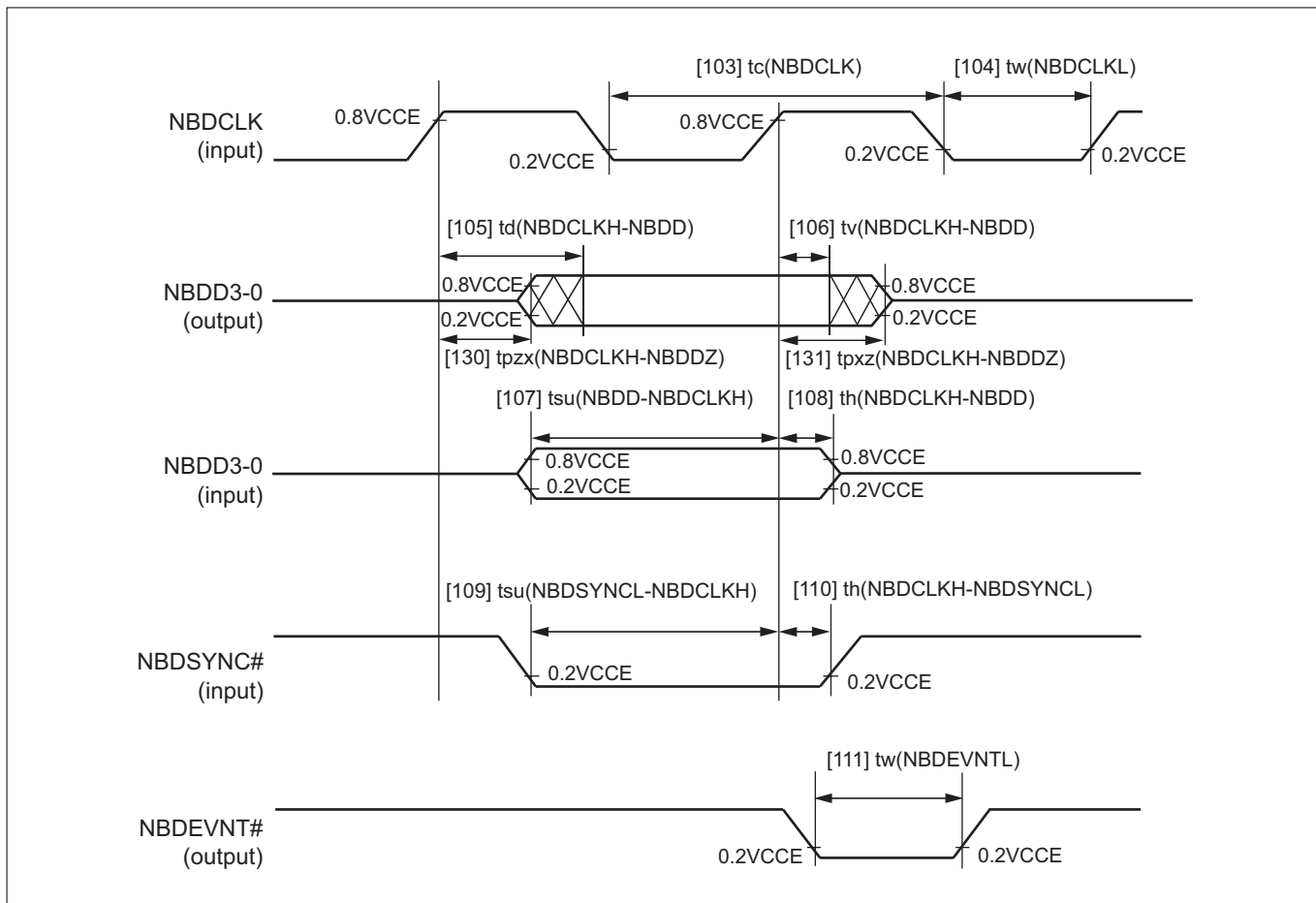


Figure 23.10.19 NBD Timing

## (18) DRI Timing

a) When Special mode is off

	Symbol	Parameter		Rated Value		Unit	See Fig. 23.10.20
				MIN	MAX		
Timing requirements	tw(DIN)	DIN Input pulse width	DIN0, DIN1, DIN2, DIN3, DIN4	1.5 x tc(BCLK)		ns	[138]
	tc(DCAP)	Import period	When Input data bus width is 8, 16 bit	3.5 x tc(BCLK)		ns	[139]
			When Input data bus width is 32 bit	4 x tc(BCLK)		ns	
	tsu(DD-E)	DD Input - Import Edge Set up time (Note 1)	When DIN2, DIN3, DIN4 are selected in Inport event	20		ns	[140]
			When DIN5 is selected in Inport event	60		ns	
	th(E-DD)	Import Edge - DD Input Hold time (Note 1)	When DIN2, DIN3, DIN4 are selected in Inport event	15 + tc(BCLK)		ns	[141]
			When DIN5 is selected in Inport event	15 + tc(BCLK)		ns	
ts <sup>iE-E</sup> j	Edge interval that Event detection is not simultaneous	DIN0, DIN1, DIN2, DIN3, DIN4	15 + tc(BCLK)		ns	[142]	

Note 1: This standard value is when considering Inport timing as a default setup. If it is not, standard value is considered with the point that is shifted back from standard edge for tv(BCLK).

b) When Special mode is on

	Symbol	Parameter		Rated Value		Unit	See Fig. 23.10.20
				MIN	MAX		
Timing requirements	tw(DIN)	DIN Input pulse width	DIN0, DIN1, DIN2, DIN4	1.5 x tc(BCLK)		ns	[138]
			DIN3	0.8 x tc(BCLK)		ns	
	tc(DCAP)	Import period	When Input data bus width is 8, 16 bit	2 x tc(BCLK)		ns	[139]
	tsu(DD-E)	DD Input - Import Edge Set up time	When DIN3 is selected in Inport event	20		ns	[140]
	th(E-DD)	Import Edge - DD Input Hold time	When DIN3 is selected in Inport event	20		ns	[141]
	ts(E-E)	Edge interval that Event detection is not simultaneous	DIN0, DIN1, DIN2, DIN4	15 + tc(BCLK)		ns	[142]
	tar	Indefinite period of DIN3 Sampling Edge by DIN1 before exiting reset initializing level		20		ns	[143]
tbr	Indefinite period of DIN3 Sampling Edge by DIN1 after exiting reset initializing level		20		ns	[144]	

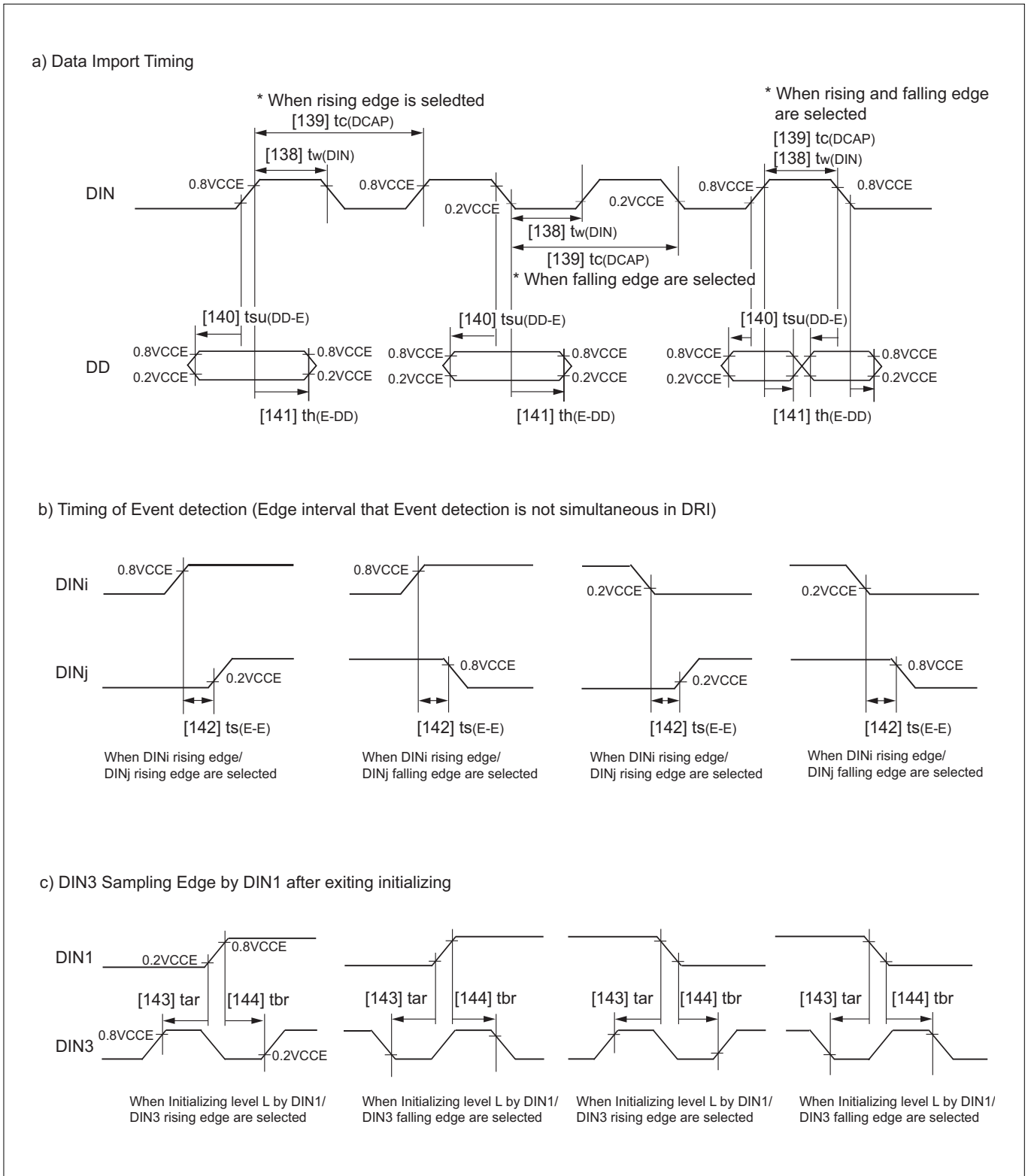


Figure 23.10.20 DRI Timing

This page is blank for reasons of layout.

## **APPENDIX 1**

---

# **MECHANICAL SPECIFICATIONS**

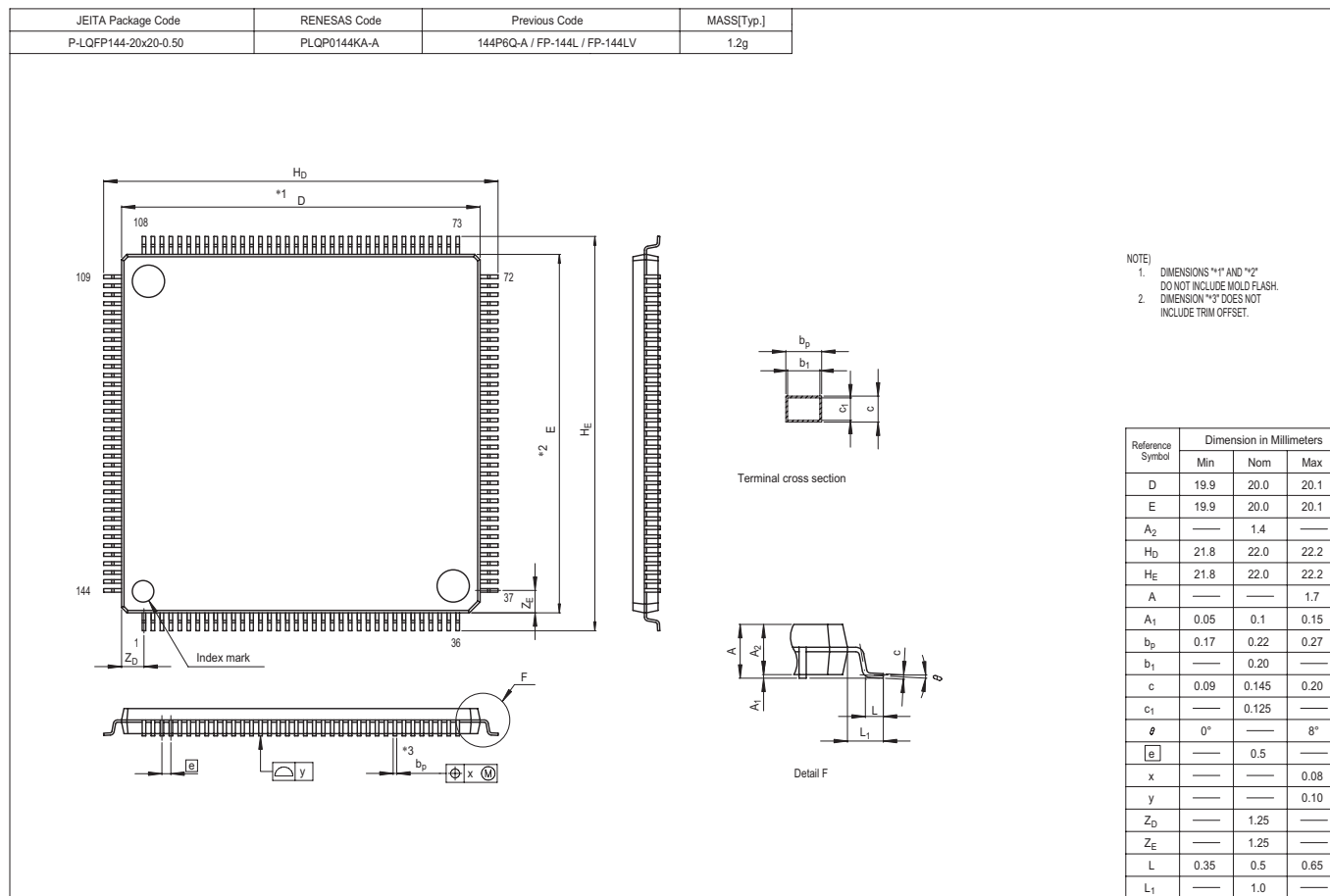
Appendix 1.1 Dimensional Outline Drawing

# Appendix 1

## MECHANICAL SPECIFICATIONS Appendix 1.1 Dimensional Outline Drawing

### Appendix 1.1 Dimensional Outline Drawing

#### (1) 144-pin LQFP(PLQP0144KA-A)



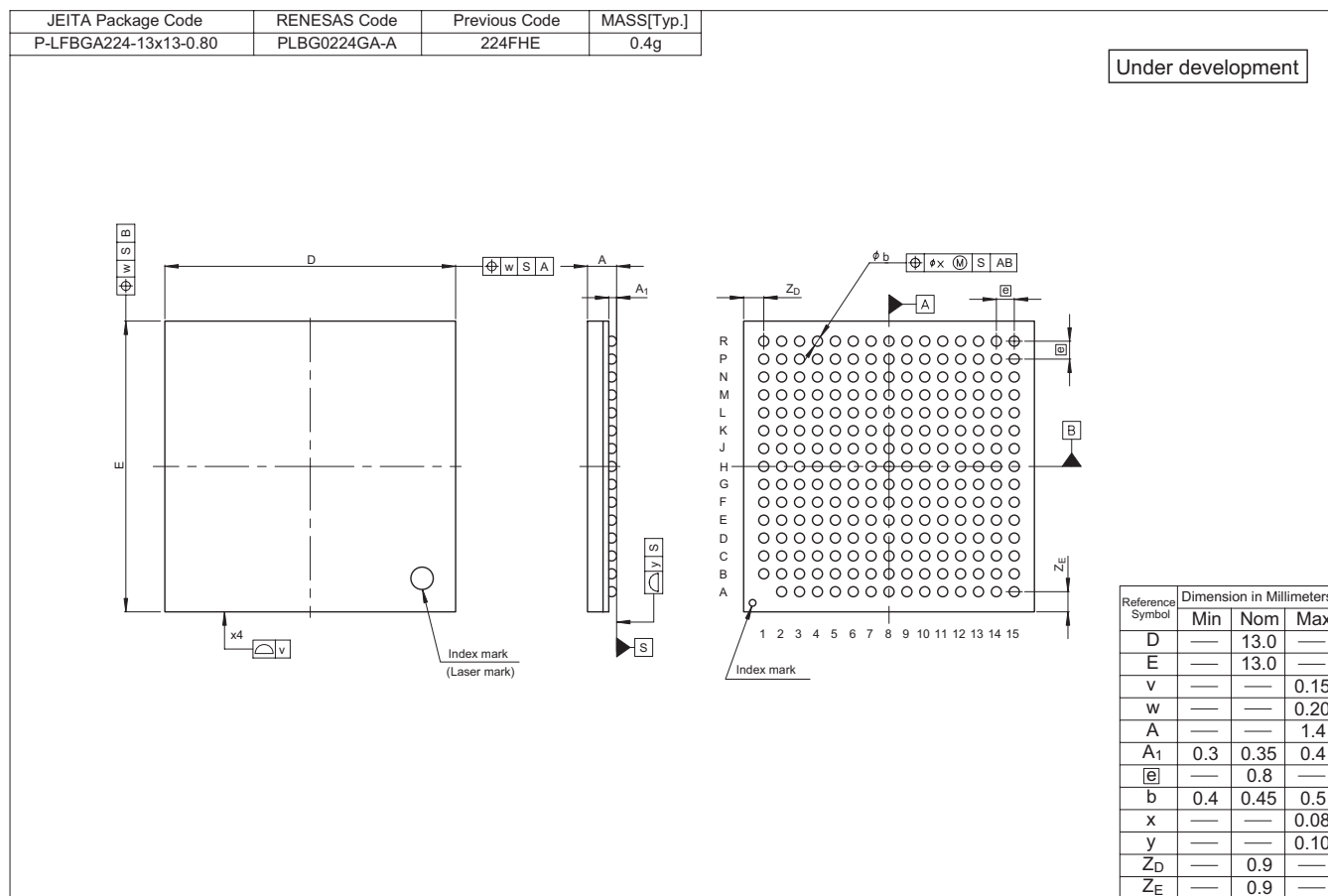
Note: • The latest Package Dimension is on Renesas Technology website.  
Please make sure whether it is the latest or not and refer to it.



# Appendix 1

## MECHANICAL SPECIFICATIONS Appendix 1.1 Dimensional Outline Drawing

### (2) 224pin FBGA(PLBG0224GA-A)



Note: • The latest Package Dimension is on Renesas Technology website.  
Please make sure whether it is the latest or not and refer to it.

This page is blank for reasons of layout.

## **APPENDIX 2**

---

# **INSTRUCTION PROCESSING TIME**

Appendix 2.1 32192/32195/32196 Instruction Processing Time

#### Appendix 2.1 32192/32195/32196 Instruction Processing Time

For microcomputers, the number of instruction execution cycles in the E stage (Note 1) normally represents their instruction processing time. However, depending on pipeline operation, other stages may affect the instruction processing time. Especially when a branch instruction is executed, the processing time in each of the IF (Instruction Fetch), D (Decode) and E (Execution) stages of the next instruction must be taken into account.

The tables below show the instruction processing time in each pipelined stage.

Note 1: Two E stages, E1 and EM, are used for the FPU instructions.

**Table 2.1.1 Instruction Processing Time in Each Pipelined Stage (Other Than FPU Instructions)**

Instruction	Number of Execution Cycles in Each Stage					
	IF	D	E	MEM1	MEM2	WB
Load instructions (LD, LDB, LDUB, LDH, LDUH, LOCK)	R(Note 1)	1	1	R(Note 1)	1	1
Store instructions (ST, STB, STH, UNLOCK)	R(Note 1)	1	1	W(Note 1)	1	(1)(Note 2)
BSET and BCLR instructions	R(Note 1)	1	R(Note 1) W(Note 1) +3		1	–
Multiply instructions (MUL)	R(Note 1)	1	3	–	–	1
Divide/remainder instructions (DIV, DIVU, REM, REMU)	R(Note 1)	1	37	–	–	1
Other instructions (including DSP function instructions BTST, SETPSW and CLRPSW)	R(Note 1)	1	1	–	–	1

Note 1: See the calculation methods for R and W described in the next page.

Note 2: Of the store instructions, only those that have register indirect + register update addressing modes require one cycle in the WB stage (but not more than that).

**Table 2.1.2 Instruction Processing Time in Each Pipelined Stage (FPU Instructions)**

Instruction	Number of Execution Cycles in Each Stage						
	IF	D	E1	EM	EA	E2	WB
FMADD and FMSUB instructions	R(Note 1)	1	–	1	1	1	1
FDIV instruction	R(Note 1)	1	14	–	–	1	1
Other FPU instructions	R(Note 1)	1	1	–	–	1	1

Note 1: See the calculation methods for R and W described in the next page.

The following shows the number of memory access cycles in the IF and MEM stages. Shown here are the minimum number of cycles required for memory access. Therefore, these values do not always reflect the number of cycles actually required for memory or bus access.

In write access, for example, although the CPU finishes the MEM stage by only writing to the write buffer, this operation actually is followed by a write to memory. Depending on the memory or bus state before or after the CPU requests a memory access, the instruction processing may take more time than the calculated value.

#### R (read cycle)

- When existing in the instruction queue . . . . . 1 CPUCLK cycle
- When reading the internal resource (RAM) . . . . . 1 CPUCLK cycle
- When reading the internal resource (ROM) . . . . . 2 CPUCLK cycles
- When reading the internal resource (SFR) (byte or halfword) . . . . . 4 CPUCLK cycles
- When reading the internal resource (SFR) (word) . . . . . 8 CPUCLK cycles
- When reading external memory (byte or halfword) . . . . . 1 CPUCLK + 1 CLKOUT cycles (Note 1)
- When reading external memory (word) . . . . . 1 CPUCLK + 2 CLKOUT cycles (Note 1)
- When successively fetching instructions from external memory . . . . . 2 CLKOUT cycles (Note 1)

#### W (write cycle)

- When writing to the internal resource (RAM) . . . . . 1 CPUCLK cycle
- When writing to the internal resource (SFR) (byte or halfword) . . . . . 4 CPUCLK cycles
- When writing to the internal resource (SFR) (word) . . . . . 8 CPUCLK cycles
- When writing to external memory (byte or halfword) . . . . . 1 CLKOUT cycle (Note 1)
- When writing to external memory (word) . . . . . 2 CLKOUT cycles (Note 1)

Note 1: This applies when external memory is accessed with zero wait state. The instruction processing time increases by 1 CLKOUT when one wait state is inserted.

Note: • CLKOUT and CPUCLK have the relationship  $1 \text{ CLKOUT} = 8 \text{ CPUCLK}$ . When CLKOUT = BCLK is selected with CLKOUT select register, the relationship  $1 \text{ CLKOUT} = 4 \text{ CPUCLK}$  is set.

This page is blank for reasons of layout.

## **APPENDIX 3**

---

# **PROCESSING OF UNUSED PINS**

Appendix 3.1 Example Processing of Unused Pins

### Appendix 3.1 Example Processing of Unused Pins

An example of how to process the unused pins of the microcomputer is shown below.

#### (1) When operating in single-chip mode

**Table 3.1.1 Example Processing of Unused Pins during Single-Chip Mode (Note 1)**

Pin Name	Processing
Input/output ports (Note 2)	
P61–P63, P70–P77, P82–87, P93–P97, P100–P107, P110–P117, P124–P127, P130–P137, P174, P175	Set the port for input mode and pull each pin low to VSS or pull high to VCCE via a 1 k $\Omega$ -10 k $\Omega$ resistor. Or set the port for output mode and leave the pin open.
P00–P07, P10–P17, P20–P27, P30–P37, P41–P47, P150, P153, P220, P221, P224, P225	Set the port for input mode and pull each pin low to VSS or pull high to VCC-BUS via a 1 k $\Omega$ -10 k $\Omega$ resistor. Or set the port for output mode and leave the pin open.
SBI# (Note 3)	Pull low to VSS via a 1 k $\Omega$ -10 k $\Omega$ resistor.
XOUT (Note 4)	Leave open
A/D converter	
AD0IN0–AD0IN15, AVREF0, AVSS0	Connect to VSS
AVCC0	Connect to VCCE
JTAG	
JTDO, JTMS, JTDI, JTCK	Pull high to VCCE or low to VSS via a 0-100 k $\Omega$ resistor
JTRST	Pull low to VSS via a 0-100 k $\Omega$ resistor

Note 1: Process the unused pins in the shortest wiring length possible (within 20 mm) from the microcomputer pins.

Note 2: If any port is set for output mode and left open, care should be taken because the port remains set for input before it is changed for output in a program after being reset. Therefore, the voltage level at the pin is instable, and the power supply current tends to increase while the port remains set for input. Because it is possible that the content of the port direction register will inadvertently be altered by noise or noise-induced runaway, higher reliability may be obtained by periodically setting the port direction register back again in a program. Note, however, that P221 is input-only port and does not work as an output port.

Note 3: Make sure that unintended falling edges due to noise, etc. will be not applied. (A falling edge at the SBI# input causes a system break interrupt to occur.)

Note 4: This is necessary when an external clock is connected to XIN.



#### (2) When operating in external extension mode

**Table 3.1.2 Example Processing of Unused Pins during External Extension Mode (Note 1)**

Pin Name	Processing
Input/output ports (Note 2)	
P61–P63, P70–P77, P82–P87, P93–P97, P100–P107, P110–P117, P124–P127, P130–P137, P174, P175	Set the port for input mode and pull each pin low to VSS or pull high to VCCE via a 1 kΩ-10 kΩ resistor. Or set the port for output mode and leave the pin open.
P00–P07, P10–P17, P20–P27, P30–P37, P44–P47, P150, P153, P220, P221, P224, P225	Set the port for input mode and pull each pin low to VSS or pull high to VCC-BUS via a 1 kΩ-10 kΩ resistor. Or set the port for output mode and leave the pin open.
BLW#/BLE#, BHW#/BHE#, RD#	Leave open
SBI# (Note 3)	Pull low to VSS via a 1 kΩ-10 kΩ resistor
XOUT (Note 4)	Leave open
A/D converter	
AD0IN0–AD0IN15, AVREF0, AVSS0	Connect to VSS
AVCC0	Connect to VCCE
JTAG	
JTDO, JTMS, JTDI, JTCK	Pull high to VCCE or low to VSS via a 0-100 kΩ resistor
JTRST	Pull low to VSS via a 0-100 kΩ resistor

Note 1: Process the unused pins in the shortest wiring length possible (within 20 mm) from the microcomputer pins.

Note 2: If any port is set for output mode and left open, care should be taken because the port remains set for input before it is changed for output in a program after being reset. Therefore, the voltage level at the pin is instable, and the power supply current tends to increase while the port remains set for input. Because it is possible that the content of the port direction register will inadvertently be altered by noise or noise-induced runaway, higher reliability may be obtained by periodically setting the port direction register back again in a program. Note, however, that P221 is input-only port and does not work as an output port.

Note 3: Make sure that unintended falling edges due to noise, etc. will be not applied. (A falling edge at the SBI# input causes a system break interrupt to occur.)

Note 4: This is necessary when an external clock is connected to XIN.

### (3) When operating in processor mode

**Table 3.1.3 Example Processing of Unused Pins during Processor Mode (Note 1)**

Pin Name	Processing
Input/output ports (Note 2)	
P61–P63, P70–P77, P82–P87, P93–P97, P100–P107, P110–P117, P126, P127, P130–P137, P174, P175	Set the port for input mode and pull each pin low to VSS or pull high to VCCE via a 1 k $\Omega$ -10 k $\Omega$ resistor. Or set the port for output mode and leave the pin open.
P150, P153, P220, P221	Set the port for input mode and pull each pin low to VSS or pull high to VCC-BUS via a 1 k $\Omega$ -10 k $\Omega$ resistor. Or set the port for output mode and leave the pin open
A9–A30, DB0–DB15, BLW#/BLE#, BHW#/BHE#, RD#, CS0#, CS1#	Leave open
SBI# (Note 3)	Pull low to VSS via a 1 k $\Omega$ -10 k $\Omega$ resistor
XOUT (Note 4)	Leave open
A/D converter	
AD0IN0–AD0IN15, AVREF0, AVSS0	Connect to VSS
AVCC0	Connect to VCCE
JTAG	
JTDO, JTMS, JTDI, JTCK	Pull high to VCCE or low to VSS via a 0-100 k $\Omega$ resistor
JTRST	Pull low to VSS via a 0-100 k $\Omega$ resistor

Note 1: Process the unused pins in the shortest wiring length possible (within 20 mm) from the microcomputer pins.

Note 2: If any port is set for output mode and left open, care should be taken because the port remains set for input before it is changed for output in a program after being reset. Therefore, the voltage level at the pin is instable, and the power supply current tends to increase while the port remains set for input. Because it is possible that the content of the port direction register will inadvertently be altered by noise or noise-induced runaway, higher reliability may be obtained by periodically setting the port direction register back again in a program. Note, however, that P221 is input-only port and does not work as an output port.

Note 3: Make sure that unintended falling edges due to noise, etc. will be not applied. (A falling edge at the SBI# input causes a system break interrupt to occur.)

Note 4: This is necessary when an external clock is connected to XIN.

## APPENDIX 4

---

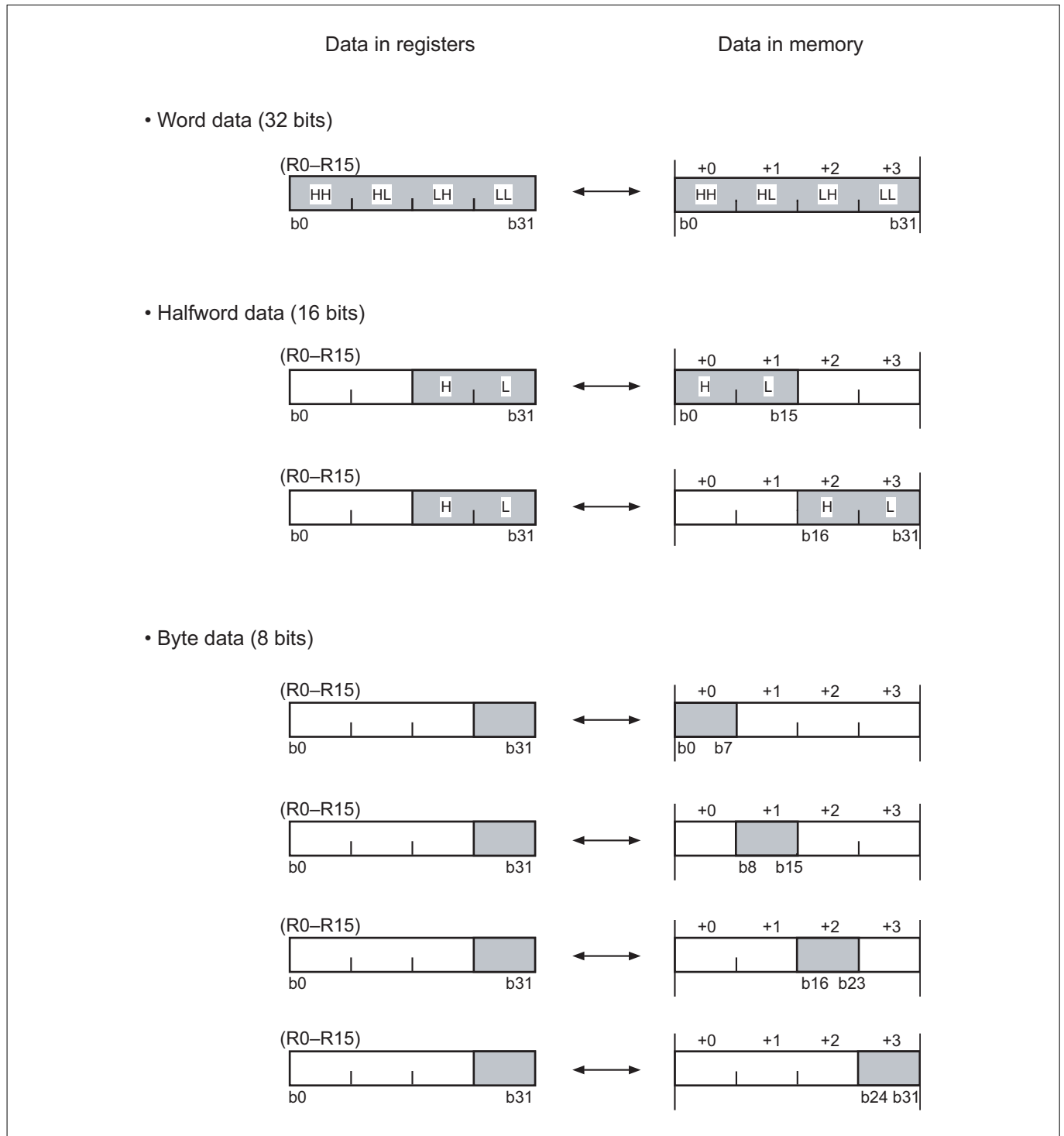
### SUMMARY OF PRECAUTIONS

- Appendix 4.1 Notes on the CPU
- Appendix 4.2 Notes on Address Space
- Appendix 4.3 Notes on EIT
- Appendix 4.4 Notes on the Internal RAM
- Appendix 4.5 Notes on the Internal Flash Memory
- Appendix 4.6 Things to Be Considered upon Exiting Reset
- Appendix 4.7 Notes on Input/Output Ports
- Appendix 4.8 Notes on the DMAC
- Appendix 4.9 Notes on Multijunction Timers
- Appendix 4.10 Notes on the A/D Converter
- Appendix 4.11 Notes on Serial Interface
- Appendix 4.12 Notes on CAN Module
- Appendix 4.13 Notes on DRI
- Appendix 4.14 Notes on RAM Backup Mode
- Appendix 4.15 Notes on JTAG
- Appendix 4.16 Notes on Noise

#### Appendix 4.1 Notes on the CPU

- Notes on data transfer

When transferring data, be aware that data arrangements in registers and memory are different.



Appendix Figure 4.1.1 Differences in Data Arrangements

## Appendix 4.2 Notes on Address Space

### • Virtual flash emulation function

The microcomputer has the function to map 8-Kbyte memory blocks of the internal RAM (maximum for 32192 is 16 blocks, for 32195 is 4 blocks, for 32196 is 8 blocks) into areas (L banks) of the internal flash memory that are divided in 8-Kbyte units. This function is referred to as the Virtual Flash Emulation Function.

This function allows the data located in 8-Kbyte blocks of the internal RAM to be changed with the contents of internal flash memory at the addresses specified by the Virtual Flash L Bank Register. That way, the relevant RAM data can read out by reading the content of internal flash memory. For details about this function, see Section 6.7, "Virtual Flash Emulation Function."

### • Dummy access area

Address H'0080 0600 to H'0080 0603 are dummy areas.

When there is access to these areas, writing value is disabled and reading value is undefined.

In addition, it does not effect on the other SFR area by writing and reading out operation to dummy access area.

## Appendix 4.3 Notes on EIT

The Address Exception (AE) requires caution because if one of the instructions that use "register indirect + register update" addressing mode (following three) generates an address exception when it is executed, the values of the registers to be automatically updated (Rsrc and Rsrc2) become undefined.

Except that the values of Rsrc and Rsrc2 become undefined, these instructions behave the same way as when used in other addressing modes.

### • Applicable instructions

LD Rdest, @Rsrc+

ST Rsrc1, @-Rsrc2

ST Rsrc1, @+Rsrc2

If the above case applies, consider the fact that the register values become undefined when you design the processing to be performed after executing said instructions. (If an address exception occurs, it means that the system has some fatal fault already existing in it. Therefore, address exceptions must be used on condition that control will not be returned from the address exception handler to the program that was being executed when the exception occurred.)

## Appendix 4.4 Notes on the Internal RAM

Precautions about the Internal Memory is shown below.

- The writes from DRI,RTD to internal RAM uncomplete with access from other bus masters (CPU, DMA, NBD, SDI), because of using dedicated bus not M32R-FPU.

But in case DRI,RTD transfers and access from other bus masters for area in 16-Kbyte of internal RAM occur at same time, access competition occurs.

When access competition occurs, arbitration is performed according to the following priority.

NBD/SDI > DMA > CPU > DRI > RTD

- When started by boot mode, internal RAM value is indefinite after started by boot mode in order to "Flash writing/erasing program" is transferred to internal RAM.

### Appendix 4.5 Notes on the Internal Flash Memory

The following describes precautions to be taken when programming/erasing the internal flash memory.

- When the internal flash memory is programmed or erased, a high voltage is generated internally. Because mode transitions during programming/erase operation may cause the chip to break down, make sure the mode setting/reset pin and power supply voltages do not fluctuate to prevent unintended changes of modes.
- If the system uses any pins that are to be used by a general-purpose programming/erase tool, care must be taken to prevent adverse effects on the system when the tool is connected.
- If the internal flash memory needs to be protected while using a general-purpose programming/erase tool, set any ID in the flash memory protect ID verification area (H'0000 0084 to H'0000 008F).
- If the internal flash memory does not need to be protected while using a general-purpose programming/erase tool, fill the entire flash memory protect ID verification area (H'0000 0084 to H'0000 008F) with H'FF.
- If the Flash Status Register (FSTAT)'s each error status is to be cleared (initialized to H'80) by resetting the Flash Control Register 4 (FCNT4) FRESET bit, check to see that the Flash Status Register (FSTAT) FBUSY bit = "1" (ready) before clearing the error status.
- Before resetting the Flash Control Register 1 (FCNT1) FENTRY bit from "1" to "0," check to see that the Flash Status Register (FSTAT) FBUSY bit = "1" (ready).
- Do not clear the FENTRY bit if the Flash Control Register 1 (FCNT1) FENTRY bit = "1" and the Flash Status Register (FSTAT) FBUSY bit = "0" (being programmed or erased).
- When programming/erasing via JTAG, the flash memory can be programmed or erased regardless of the pin state because the FP pin is controlled internally within the chip.

### Appendix 4.6 Things to Be Considered upon Exiting Reset

#### • Input/output ports

When exiting reset, the microcomputer's input/output ports are disabled against input in order to prevent shoot-through current. To use any ports in input mode, set the Port Input Special Function Control Register (PICNT) PIEN0 bit to enable them for input. For details, see Section 8.3, "Input/Output Port Related Registers."

## Appendix 4.7 Notes on Input/Output Ports

- **When using input/output ports in output mode**

Because the value of the Port Data Register is undefined when exiting the reset state, the Port Data Register must have its initial value set in it before the Port Direction Register can be set for output. Conversely, if the Port Direction Register is set for output before setting data in the Port Data Register, the Port Data Register outputs an undefined value until any data is written into it.

- **When using input/output ports in input mode**

After switching from output mode to input mode in the Port Direction Register, or after setting port input enable (PIEN0) bit to "1" (input enable), pin level can be read after 2BCLK period.

- **About the port input disable function**

Because the input/output ports are disabled against input upon exiting reset, they must be enabled for input by setting the Port Input Enable (PIEN0) bit to "1" before their input functions can be used.

When disabled against input, the input/output ports are in a state equivalent to a situation where the pin has a "L" level input applied. Consequently, if a peripheral input function (uncontrolled pin) is selected for any port while disabled against input by using the Port Operation Mode Register, the port may operate unexpectedly due to the "L" level input on it.

- **About the port peripheral function select register setting**

The Port Peripheral Function Select Register can only be set when the corresponding bit of the Port Operation Mode Register is "0."

- **About the peripheral function input when it is set to the general-purpose port**

In the pin for both peripheral function input and general-purpose port, "H" level is entered to the peripheral function input when it is set to the general-purpose port in the operation mode register. Therefore, when "L" level is entered to the peripheral function input pin, edge signal is entered to the peripheral function input at manipulating operation mode register.

## Appendix 4.8 Notes on the DMAC

### • About writing to the DMAC related registers

Because DMA transfer involves exchanging data via the internal bus, the DMAC related registers basically can only be accessed for write upon exiting the reset state or when transfer is disabled (transfer enable bit = "0"). When transfer is enabled, do not write to the DMAC related registers, except the DMA transfer enable bit, the transfer request flag, DMA interrupt related register and the DMA Transfer Count Register that is protected in hardware. This is a precaution necessary to ensure stable DMA operation.

The table below lists the registers that can or cannot be accessed for write.

**Appendix Table 4.8.1 DMAC Related Registers That Can or Cannot Be Accessed for Write**

Status	Transfer enable bit	Transfer request flag	DMA interrupt related register	Other DMAC related registers
Transfer enabled	Can be accessed	Can be accessed	Can be accessed	Cannot be accessed
Transfer disabled	Can be accessed	Can be accessed	Can be accessed	Can be accessed

Even for registers that can exceptionally be written to while transfer is enabled, the following conditions must be observed:

#### (1) DMA Channel Control Register 0 transfer enable bit and transfer request flag

For all bits other than transfer enable bit and transfer request flag in this register, be sure to write the same data that those bits had before the write. Note, however, that only writing "0" is effective for the transfer request flag.

#### (2) DMA Transfer Count Register

When transfer is enabled, this register is protected in hardware, so that any data rewritten to it is ignored.

#### (3) Rewriting the DMA source and DMA destination addresses on different channels by DMA transfer

Although this operation means accessing the DMAC related registers while DMA is enabled, there is no problem. Note, however, that no data can be transferred by DMA to the DMAC related registers on the currently active channel itself.

### • Manipulating the DMAC related registers by DMA transfer

When manipulating the DMAC related registers by means of DMA transfer (e.g., reloading the DMAC related registers with the initial values by DMA transfer), do not write to the DMAC related registers on the currently active channel through that channel. (If this precaution is neglected, device operation cannot be guaranteed.)

It is only the DMAC related registers on other channels that can be rewritten by means of DMA transfer. (For example, the DMA Source Address and DMA Destination Address Registers on channel 1 can be rewritten by DMA transfer through channel 0.)

### • About the DMA Interrupt Request Status Register

When clearing the DMA Interrupt Request Status Register, be sure to write "1" to all bits, except those to be cleared. Writing "1" to any bits in this register has no effect, so that they retain the data they had before the write.

### • About the stable operation of DMA transfer

To ensure the stable operation of DMA transfer, never rewrite the DMAC related registers, except transfer enable bits of the DMA channel control register 0, unless transfer is disabled. One exception is that even when transfer is enabled, the DMA Source Address and DMA Destination Address Registers can be rewritten by DMA transfer from one channel to another.



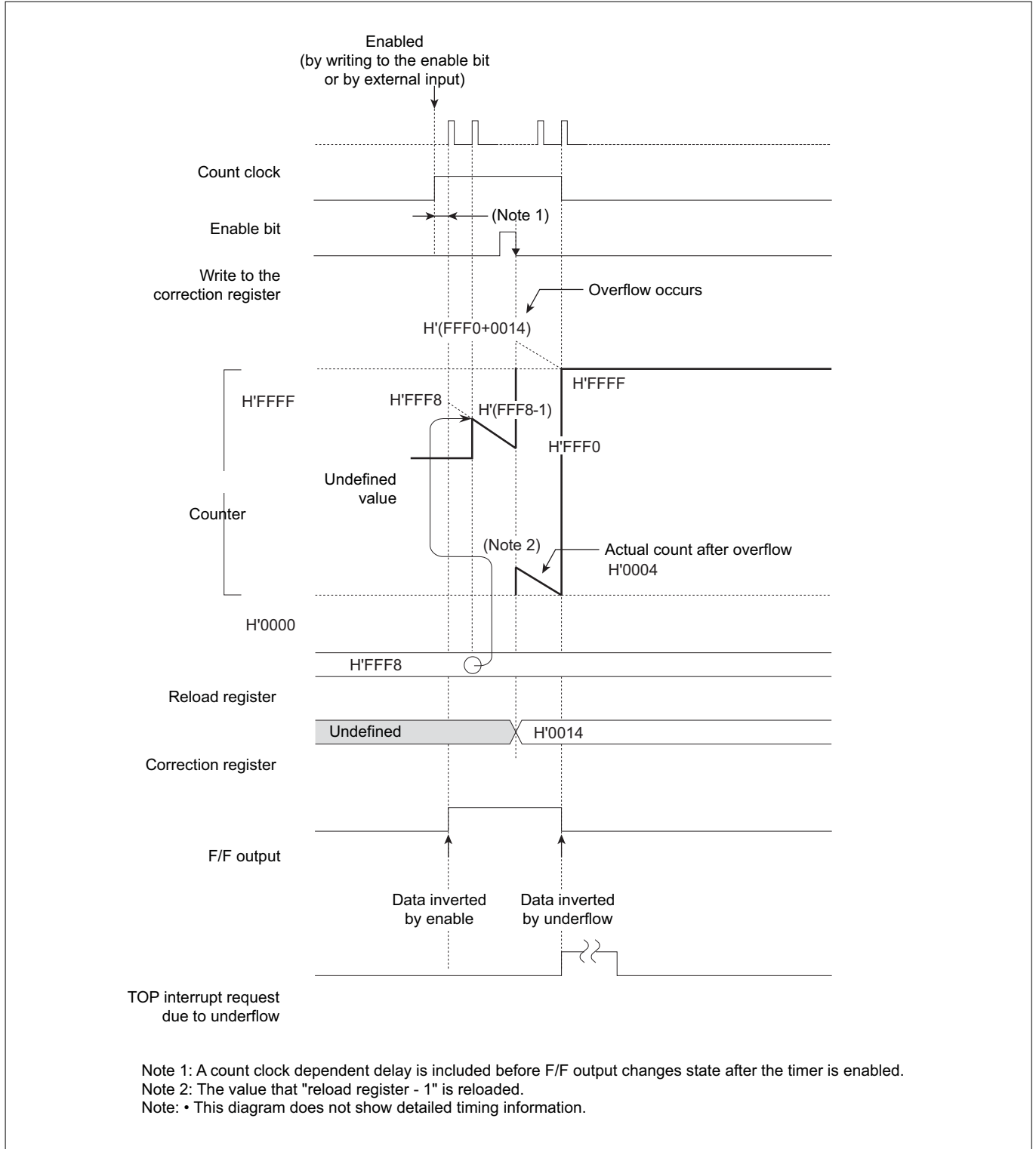
## Appendix 4.9 Notes on Multijunction Timers

### Appendix 4.9.1 Notes on using TOP single-shot output mode

The following describes precautions to be observed when using TOP single-shot output mode.

- If the counter stops due to an underflow in the same clock period as the timer is enabled by external input, the former has priority so that the counter stops.
- If the counter stops due to an underflow in the same clock period as count is enabled by writing to the enable bit, the latter has priority so that count is enabled.
- If the timer is enabled by external input in the same clock period as count is disabled by writing to the enable bit, the latter has priority so that count is disabled.
- Because the timer operates synchronously with the count clock, a count clock-dependent delay is included before F/F output is inverted after the timer is enabled.
- When writing to the correction register, be careful not to cause the counter to overflow. Even if the counter overflows due to correction of counts, no interrupt requests are generated for reasons of an overflow. Therefore, if the counter underflows in the subsequent down-count after an overflow, a false interrupt request is generated for an underflow that includes the overflowed count.

In the example below, the reload register is initially set to H'FFF8. When the timer starts, the value that "the reload register - 1" is loaded into the counter, letting it start counting down. In the diagram below, the value H'0014 is written to the correction register when the counter has counted down to H'FFF0. As a result of this correction, the count overflows to H'0004 and the counter fails to count correctly. Also, an interrupt request is generated for an erroneous overflowed count.

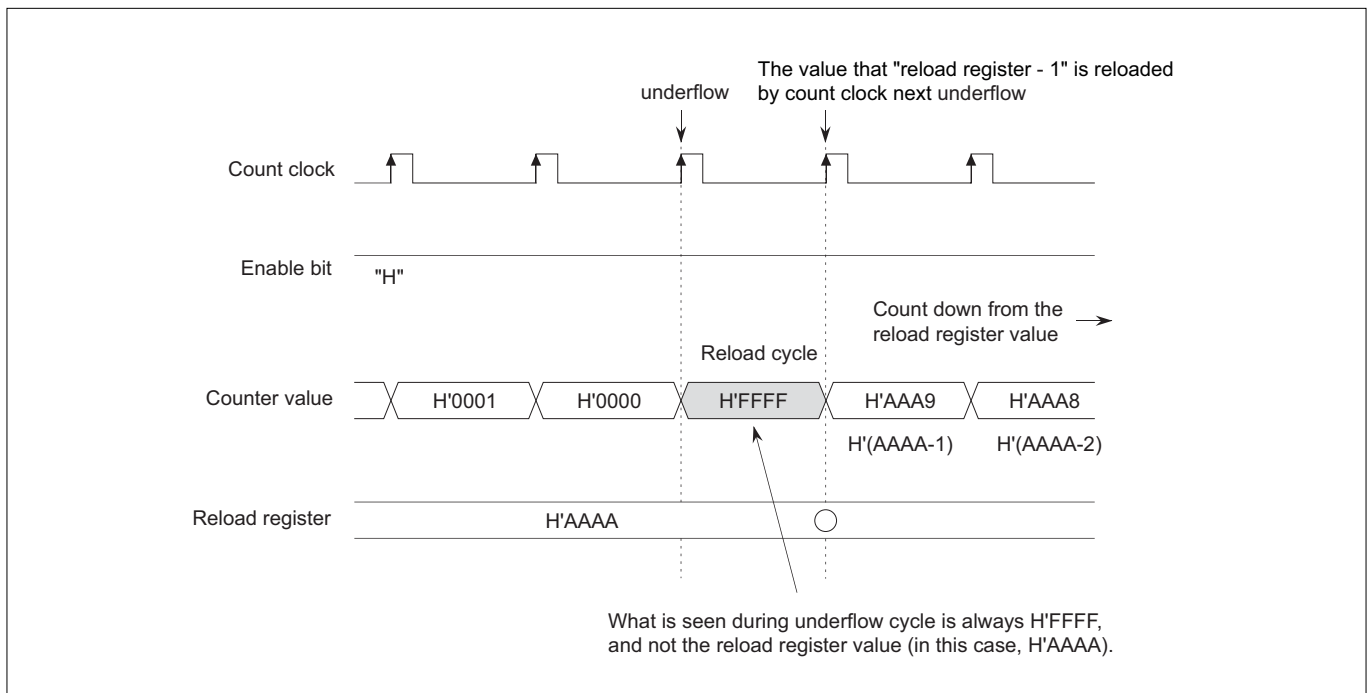


**Appendix Figure 4.9.1 Example of an Operation in TOP Single-shot Output Mode Where Count Overflows Due to Correction**

### Appendix 4.9.2 Notes on using TOP delayed single-shot output mode

The following describes precautions to be observed when using TOP delayed single-shot output mode.

- If the counter stops due to an underflow in the same clock period as the timer is enabled by external input, the former has priority so that the counter stops.
- If the counter stops due to an underflow in the same clock period as count is enabled by writing to the enable bit, the latter has priority so that count is enabled.
- If the timer is enabled by external input in the same clock period as count is disabled by writing to the enable bit, the latter has priority so that count is disabled.
- Even if the counter overflows due to correction of counts, no interrupt requests are generated for reasons of an overflow. Therefore, if the counter underflows in the subsequent down-count after an overflow, a false interrupt request is generated for an underflow that includes the overflowed count.
- If the counter is accessed for read at the cycle of underflow, the counter value is read as H'FFFF but changes to "reload register value - 1" at the next count clock timing after underflow.



**Appendix Figure 4.9.2 Counter Value Immediately after Underflow**

### Appendix 4.9.3 Notes on using TOP continuous output mode

The following describes precautions to be observed when using TOP continuous output mode.

- If the timer is enabled by external input in the same clock period as count is disabled by writing to the enable bit, the latter has priority so that count is disabled.
- If the counter is accessed for read at the cycle of underflow, the counter value is read as H'FFFF but changes to "reload register value -1" at the next count clock timing.
- Because the timer operates synchronously with the count clock, a count clock-dependent delay is included before F/F output is inverted after the timer is enabled.

### Appendix 4.9.4 Notes on using TIO measure free-run/ clear input modes

The following describes precautions to be observed when using TIO measure free-run/ clear input modes.

- If measure event input and write to the counter occur in the same clock period, the write value is set in the counter while at the same time latched into the measure register.

### Appendix 4.9.5 Notes on using TIO PWM output mode

The following describes precautions to be observed when using TIO PWM output mode.

- If the timer is enabled by external input in the same clock period as count is disabled by writing to the enable bit, the latter has priority so that count is disabled.
- If the counter is accessed for read at the cycle of underflow, the counter value is read as H'FFFF but changes to "reload register value -1" at the next count clock timing.
- Because the timer operates synchronously with the count clock, up to one count clock-dependent delay is generated before F/F output is inverted after writing to the enable bit.

### Appendix 4.9.6 Notes on using TIO single-shot output mode

The following describes precautions to be observed when using TIO single-shot output mode.

- If the counter stops due to an underflow in the same clock period as the timer is enabled by external input, the former has priority so that the counter stops.
- If the counter stops due to an underflow in the same clock period as count is enabled by writing to the enable bit, the latter has priority so that count is enabled.
- If the timer is enabled by external input in the same clock period as count is disabled by writing to the enable bit, the latter has priority so that count is disabled.
- Because the timer operates synchronously with the count clock, up to one count clock-dependent delay is generated before F/F output is inverted after writing to the enable bit.

### Appendix 4.9.7 Notes on using TIO delayed single-shot output mode

The following describes precautions to be observed when using TIO delayed single-shot output mode.

- If the counter stops due to an underflow in the same clock period as the timer is enabled by external input, the former has priority so that the counter stops.
- If the counter stops due to an underflow in the same clock period as count is enabled by writing to the enable bit, the latter has priority so that count is enabled.
- If the timer is enabled by external input in the same clock period as count is disabled by writing to the enable bit, the latter has priority so that count is disabled.
- If the counter is accessed for read at the cycle of underflow, the counter value is read out as H'FFFF but changes to "reload register value -1" at the next count clock timing.

### Appendix 4.9.8 Notes on using TIO continuous output mode

The following describes precautions to be observed when using TIO continuous output mode.

- If the timer is enabled by external input in the same clock period as count is disabled by writing to the enable bit, the latter has priority so that count is disabled.
- If the counter is accessed for read at the cycle of underflow, the counter value is read out as H'FFFF but changes to "reload register value -1" at the next count clock timing.
- Because the timer operates synchronously with the count clock, up to one count clock-dependent delay is generated before F/F output is inverted after writing to the enable bit.

### Appendix 4.9.9 Notes on using TMS measure input

The following describes precautions to be observed when using TMS measure input.

- If measure event input and write to the counter occur in the same clock period, the write value is set in the counter while at the same time latched into the measure register.

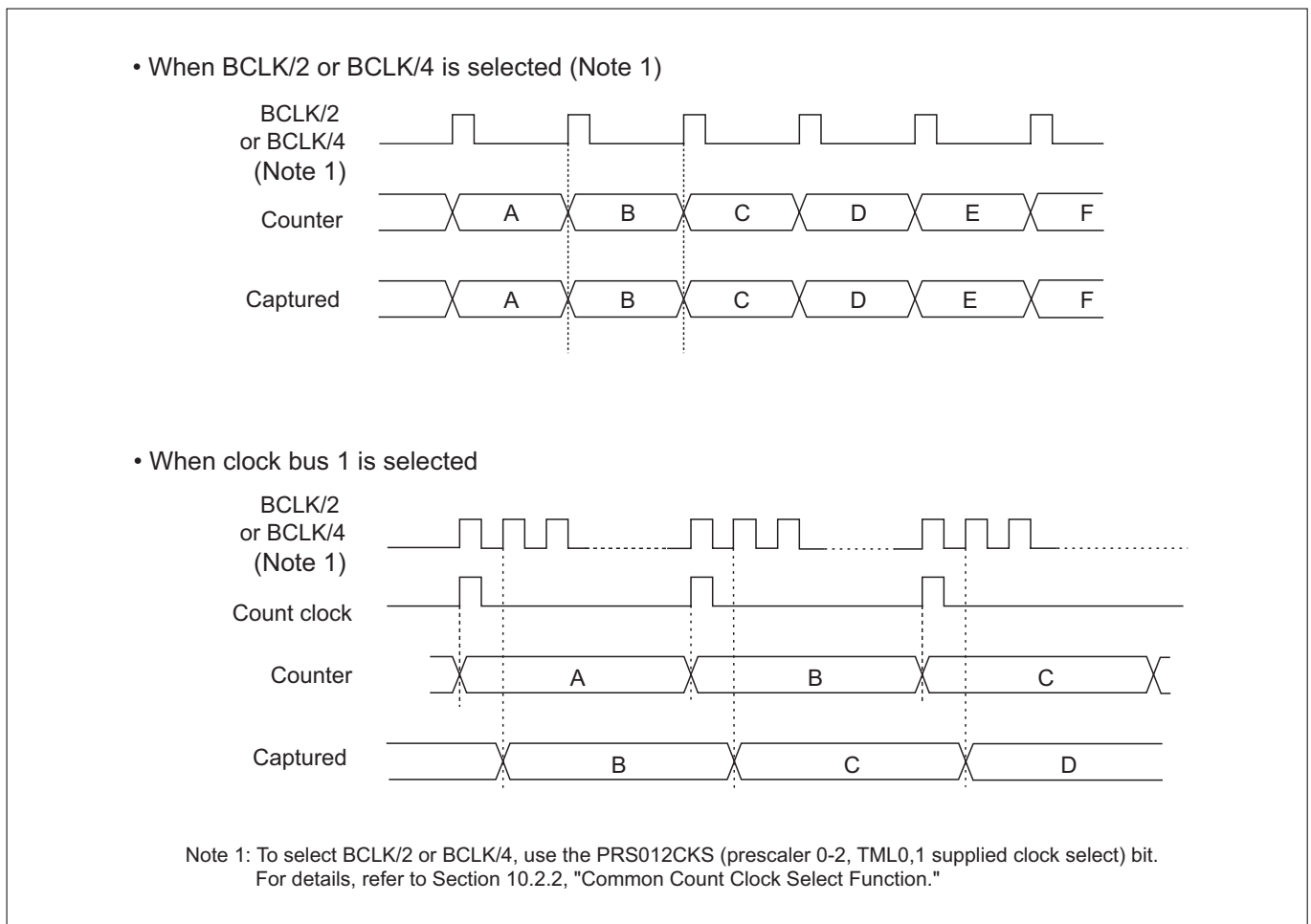
### Appendix 4.9.10 Notes on using TML measure input

The following describes precautions to be observed when using TML measure input.

- If measure event input and write to the counter occur in the same clock period, the write value is set in the counter, whereas the up-count value (before being rewritten) is latched into the measure register.
- If clock bus 1 is selected and any clock other than BCLK/2 or BCLK/4 (Note 1) is used for the timer, by divided by internal prescaler PRS1, the value captured into the measure register is one count larger the counter value. During the count clock to BCLK/2 or BCLK/4 (Note 1) period interval, however, the captured value is exactly the counter value.

The diagram below shows the relationship between counter operation and the valid data that can be captured.

Note 1: To select BCLK/2 or BCLK/4, use the PRS012CKS (prescaler 0-2, TML0,1 supplied clock select) bit. For details, refer to Section 10.2.2, "Common Count Clock Select Function."



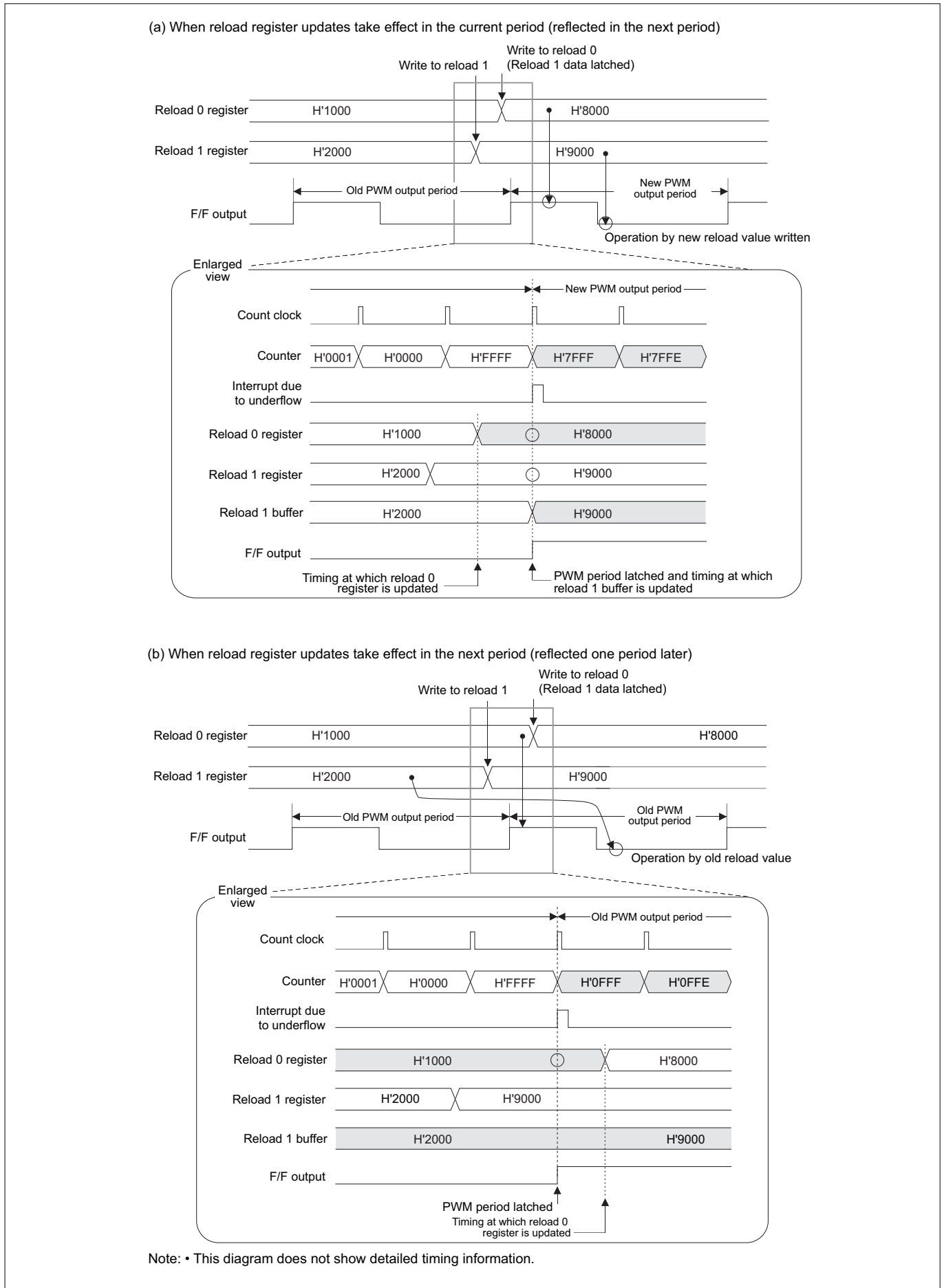
Appendix Figure 4.9.3 Mistimed Counter Value and the Captured Value

### Appendix 4.9.11 Notes on using TOU PWM output mode

The following describes precautions to be observed when using TOU PWM output mode.

- If the timer is enabled by external input in the same clock period as count is disabled by writing to the enable bit, the latter has priority so that count is disabled.
- If the counter is accessed for read to the cycle of underflow, the counter value is read out as H'FFFF but changes to "reload register value -1" at the next count clock timing.
- Because the timer operates synchronously with the count clock, a count clock-dependent delay is included before F/F output is inverted after the timer is enabled.

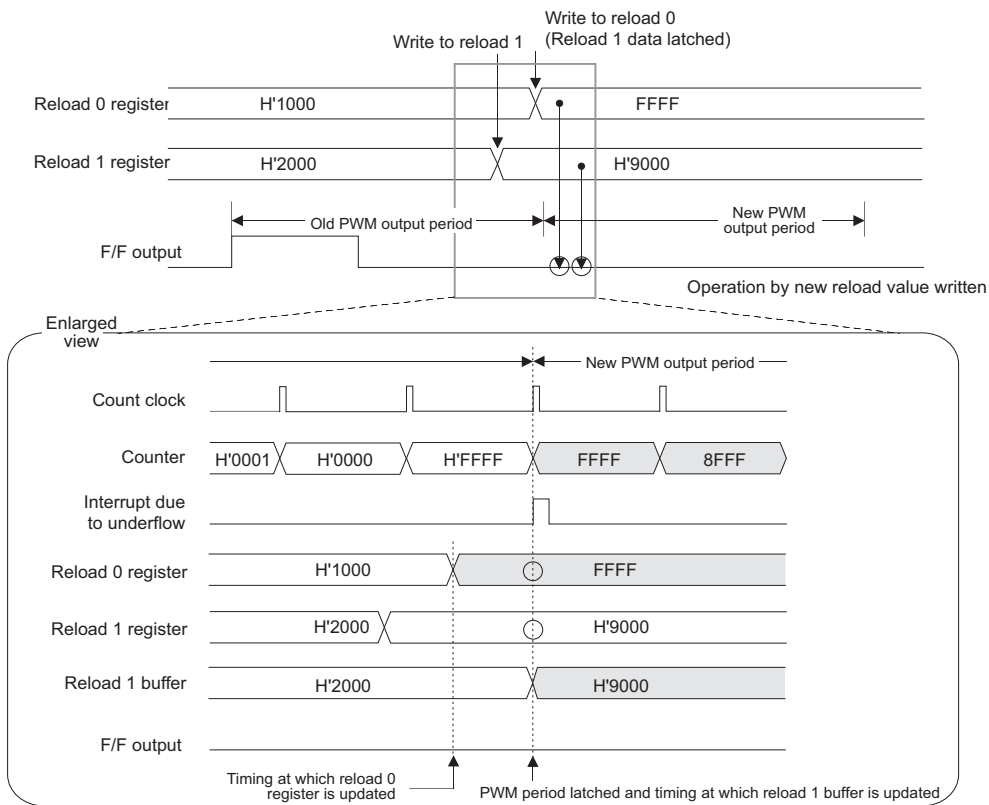
Because a 0% or 100% duty-cycle needs to be determined when reloading the counter, there is a one count clock equivalent delay before F/F is inverted and an interrupt or DMA transfer request is generated. However, startup requests to other timers are not delayed. For details, see Section 10.8.19, "0% or 100% Duty-Cycle Wave Output during PWM Output and Single-shot PWM Output Modes."



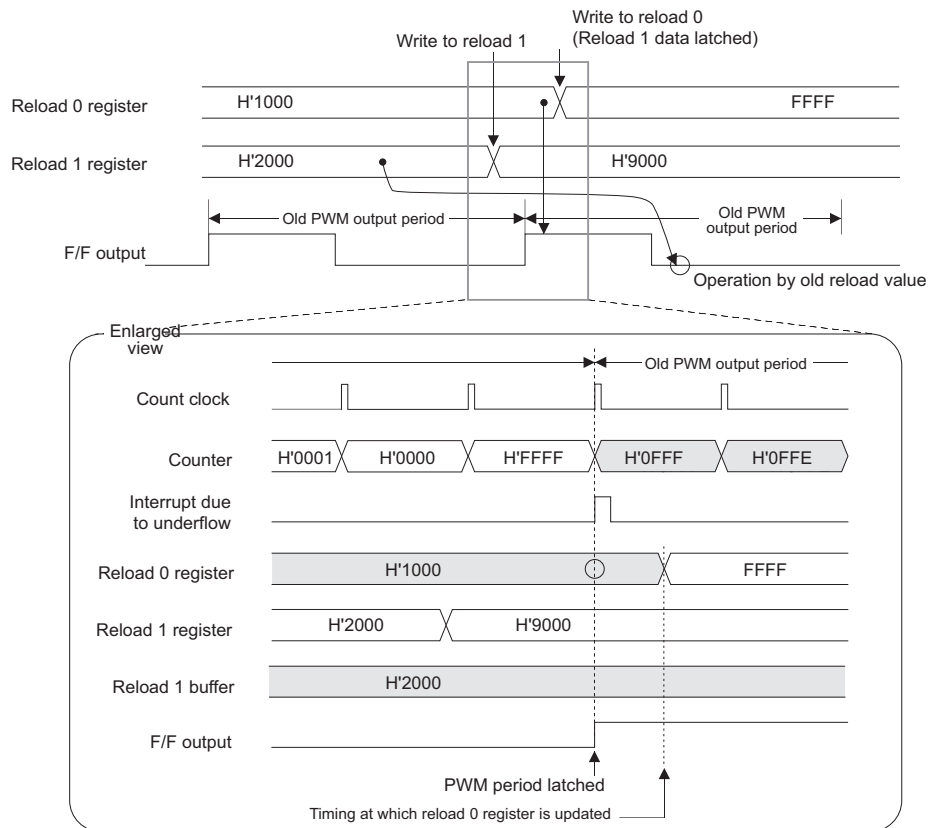
Appendix Figure 4.9.4 Reload 0 and Reload 1 Register Updates in PWM Output Mode



(a) When reload register updates take effect in the current period (reflected in the next period)



(b) When reload register updates take effect in the next period (reflected one period later)



Note: • This diagram does not show detailed timing information.

Appendix Figure 4.9.5 Reload 0 and Reload 1 Register Updates in PWM Output Mode (For 0% or 100% Duty-Cycle Wave Output)

### Appendix 4.9.12 Notes on using TOU single-shot PWM output mode

The following describes precautions to be observed when using TOU single-shot PWM output mode.

- If the timer is enabled by external input in the same clock period as count is disabled by writing to the enable bit, the latter has priority so that count is disabled.
- If the counter is accessed for read at the cycle of underflow, the counter value is read out as H'FFFF but changes to “reload register value -1” at the next count clock timing.
- Updating of reload 0 and reload 1 during timer operation does not effect PWM waveform that is outputting at present. Updating is reflected at the next PWM period after updating reload 0 register.

Because a 0% or 100% duty-cycle needs to be determined when reloading the counter, there is a one count clock equivalent delay before F/F is inverted and an interrupt or DMA transfer request is generated. However, startup requests to other timers are not delayed. For details, see Appendix 4.9.16, “0% or 100% Duty-Cycle Wave Output during PWM Output and Single-shot PWM Output Modes.”

### Appendix 4.9.13 Notes on using TOU delayed single-shot output mode

The following describes precautions to be observed when using TOU delayed single-shot output mode.

- If the counter stops due to an underflow in the same clock period as the timer is enabled by external input, the former has priority so that the counter stops.
- If the counter stops due to an underflow in the same clock period as count is enabled by writing to the enable bit, the latter has priority so that count is enabled.
- If the timer is enabled by external input in the same clock period as count is disabled by writing to the enable bit, the latter has priority so that count is disabled.
- If the counter is accessed for read at the cycle of underflow, the counter value is read as H'FF FFFF but changes to “reload register value -1” at the next count clock timing.
- Because the timer operates synchronously with the count clock, a count clock-dependent delay is included before F/F output is inverted after the timer is enabled.

### Appendix 4.9.14 Notes on using TOU single-shot output mode

The following describes precautions to be observed when using TOU single-shot output mode.

- If the counter stops due to an underflow in the same clock period as the timer is enabled by external input, the former has priority so that the counter stops.
- If the counter stops due to an underflow in the same clock period as count is enabled by writing to the enable bit, the latter has priority so that count is enabled.
- If the timer is enabled by external input in the same clock period as count is disabled by writing to the enable bit, the latter has priority so that count is disabled.
- Because the timer operates synchronously with the count clock, up to one count clock-dependent delay is generated before F/F output is inverted after writing the enable bit.

### Appendix 4.9.15 Notes on using TOU continuous output mode

The following describes precautions to be observed when using TOU continuous output mode.

- If the timer is enabled by external input in the same clock period as count is disabled by writing to the enable bit, the latter has priority so that count is disabled.
- If the counter is accessed for read at the cycle of underflow, the counter value is read out as H'FF FFFF but changes to "reload register value -1" at the next count clock timing.
- Because the timer operates synchronously with the count clock, up to one count clock-dependent delay is generated before F/F output is inverted after writing the enable bit.

### Appendix 4.9.16 0% or 100% Duty-Cycle Wave Output during PWM Output and Single-shot PWM Output Modes

During PWM output or single-shot PWM output mode, if the value "H'FFFF" is written to the reload 0 or reload 1 register, F/F output will not be inverted, making it possible to produce a 0% or 100% duty-cycle PWM output. Because determination is made to see if the reload value is "H'FFFF" during PWM output or single-shot PWM output mode, following precautions must be observed.

- (1) Because the counter counts one even when detecting 0% or 100% duty-cycle, one of the two reload registers must have set in it one less than the intended value in order for a constant-cycle waveform to be produced.

Example: If the desired output cycle is 10 counts

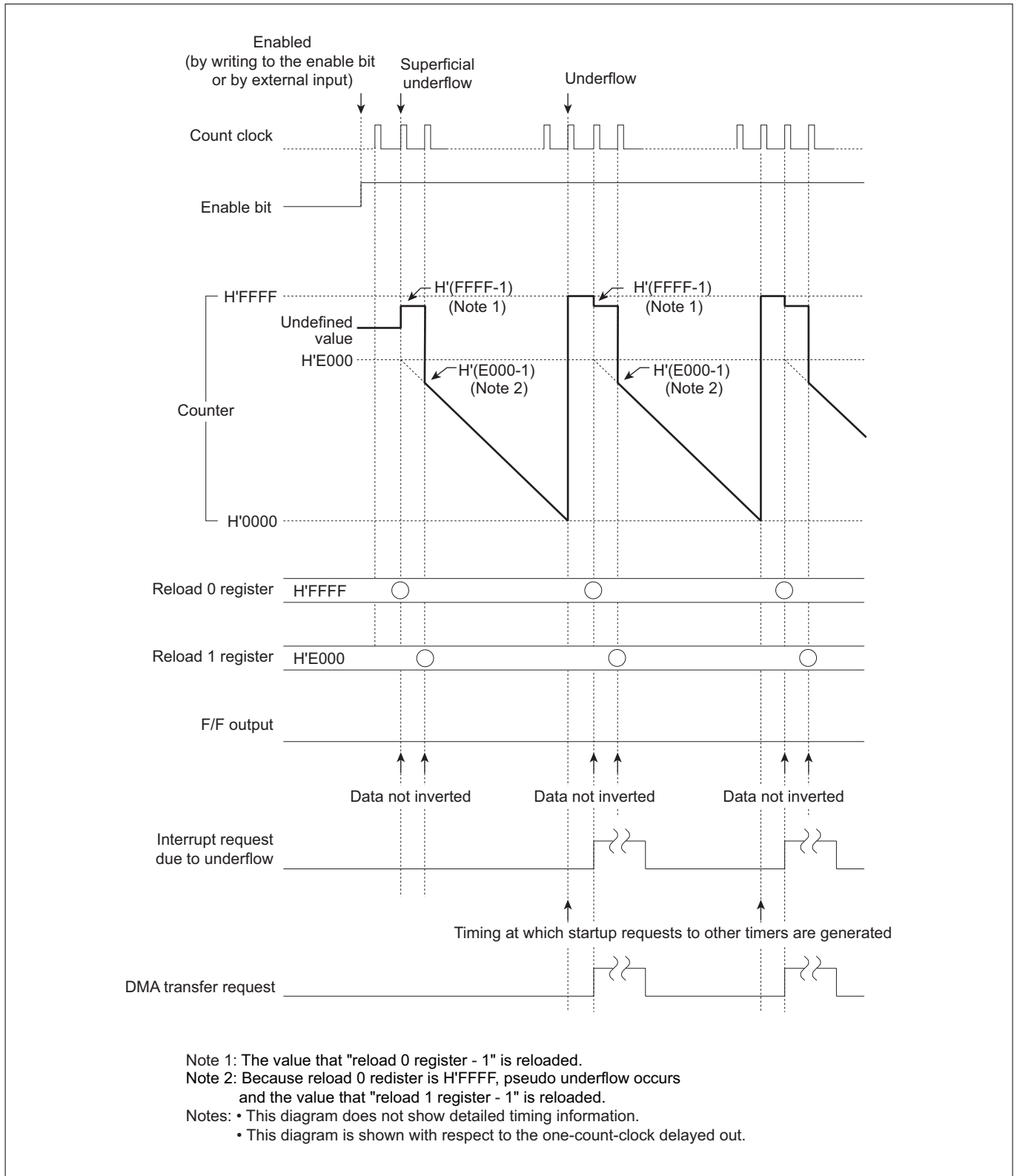
Cycle ratio	50% : 50%	80% : 20%	90% : 10%	100% : 0%
Count ratio	5 : 5	8 : 2	9 : 1	10 : 0
Register set values	0004 : 0004	0007 : 0001	0008 : 0000	0009 : FFFF

Because the counter counts  $n + 1$ , the values actually set in the respective registers must be one less than the intended value.

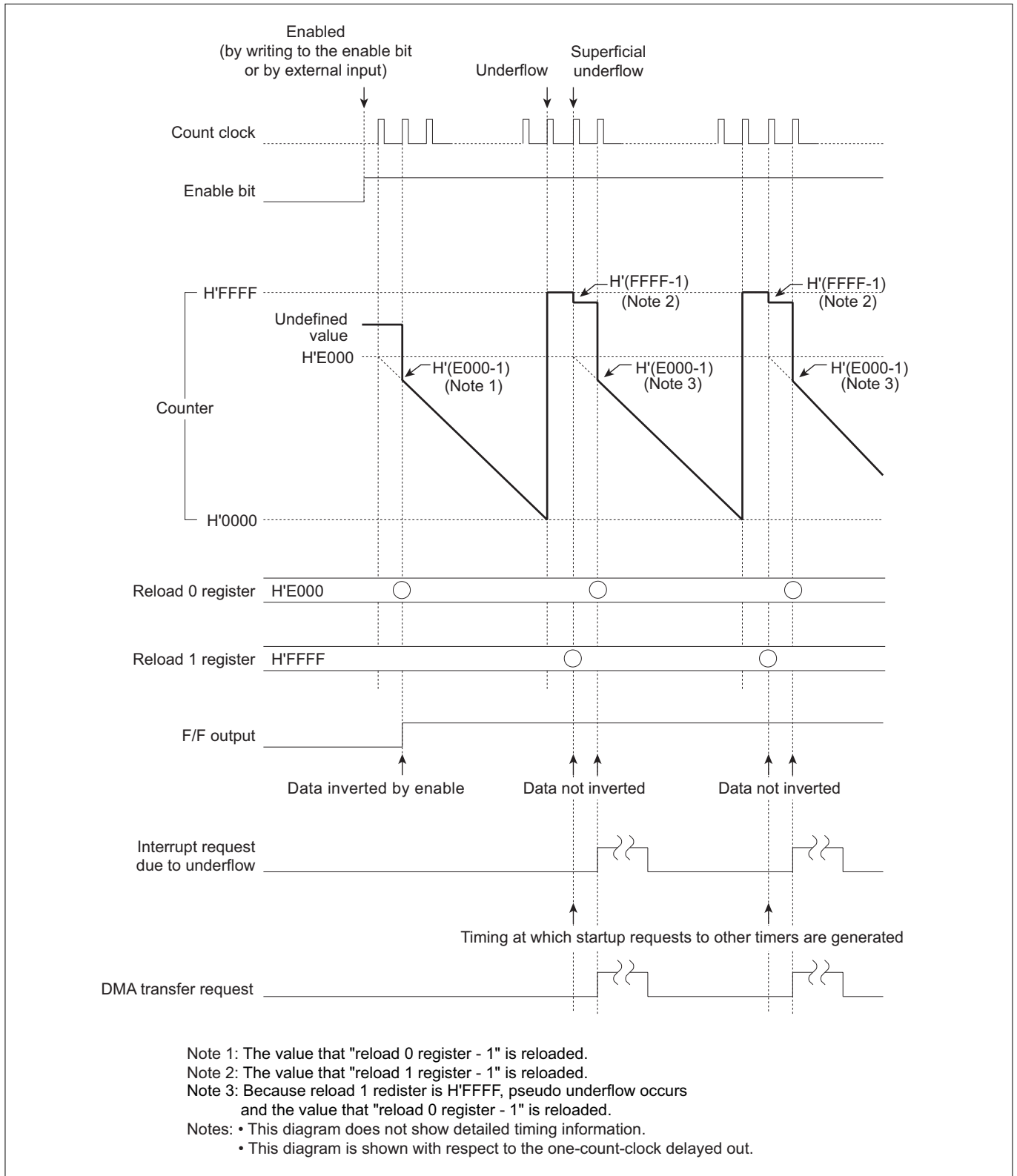
0008: FFFF

The counter counts one without inverting F/F output after detecting "FFFF." For this reason, the value to be set in the register must be "0008," and not "0009."

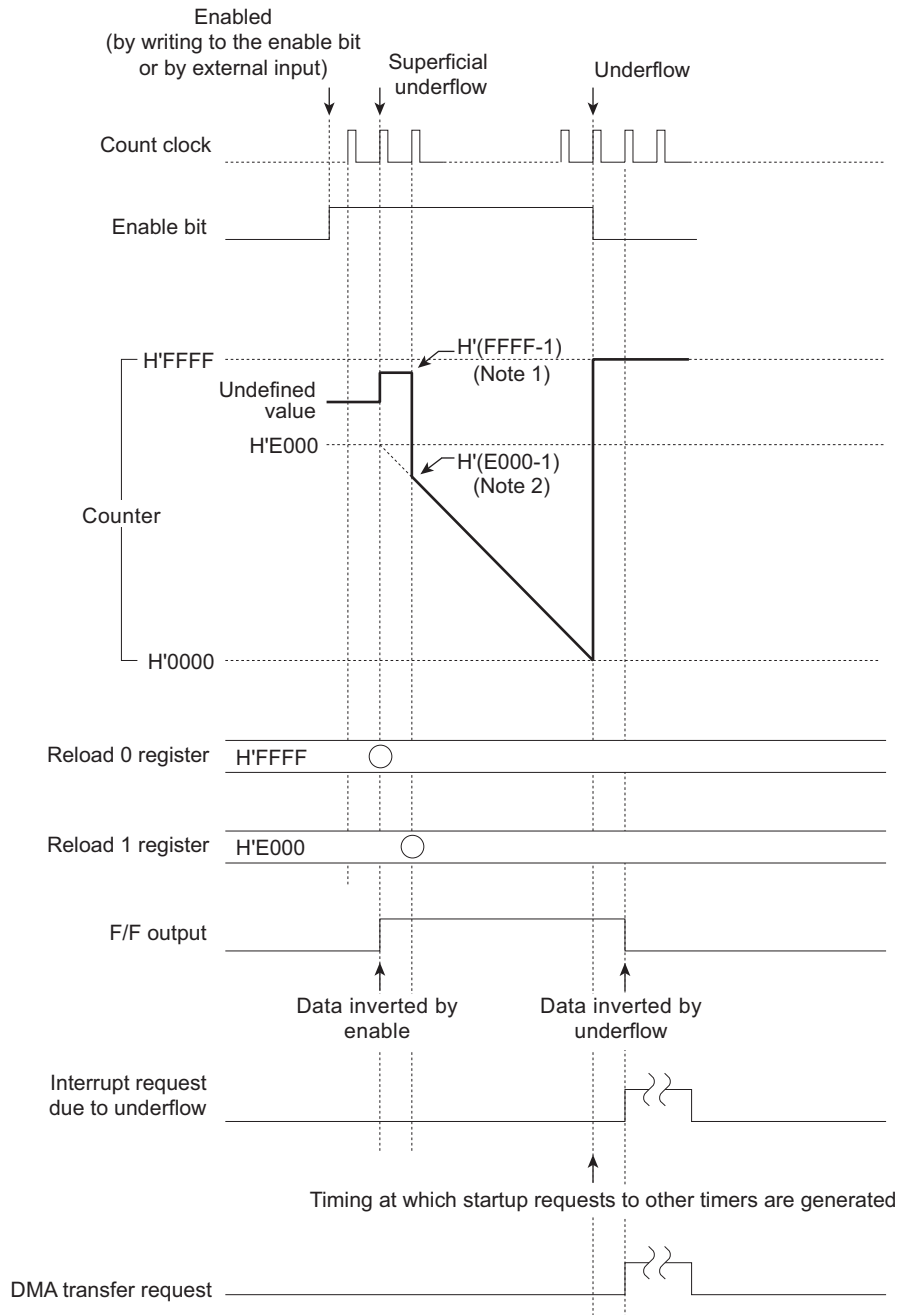
- (2) Because setting the value "H'FFFF" in the reload register produces a 0% or 100% duty-cycle, it is impossible to count the exact "H'FFFF."
- (3) Setting the value "H'FFFF" in both reload 0 and reload 1 registers is inhibited.
- (4) Writing the value "H'FFFF" to the counter while in operation is inhibited.
- (5) Even for a 0% or 100% duty-cycle, interrupt requests and startup registers to other timers are generated.
- (6) Because a 0% or 100% duty-cycle needs to be determined when reloading the counter, there is a one count clock equivalent delay before F/F is inverted and an interrupt or DMA transfer request is generated. However, startup requests to other timers are not delayed.



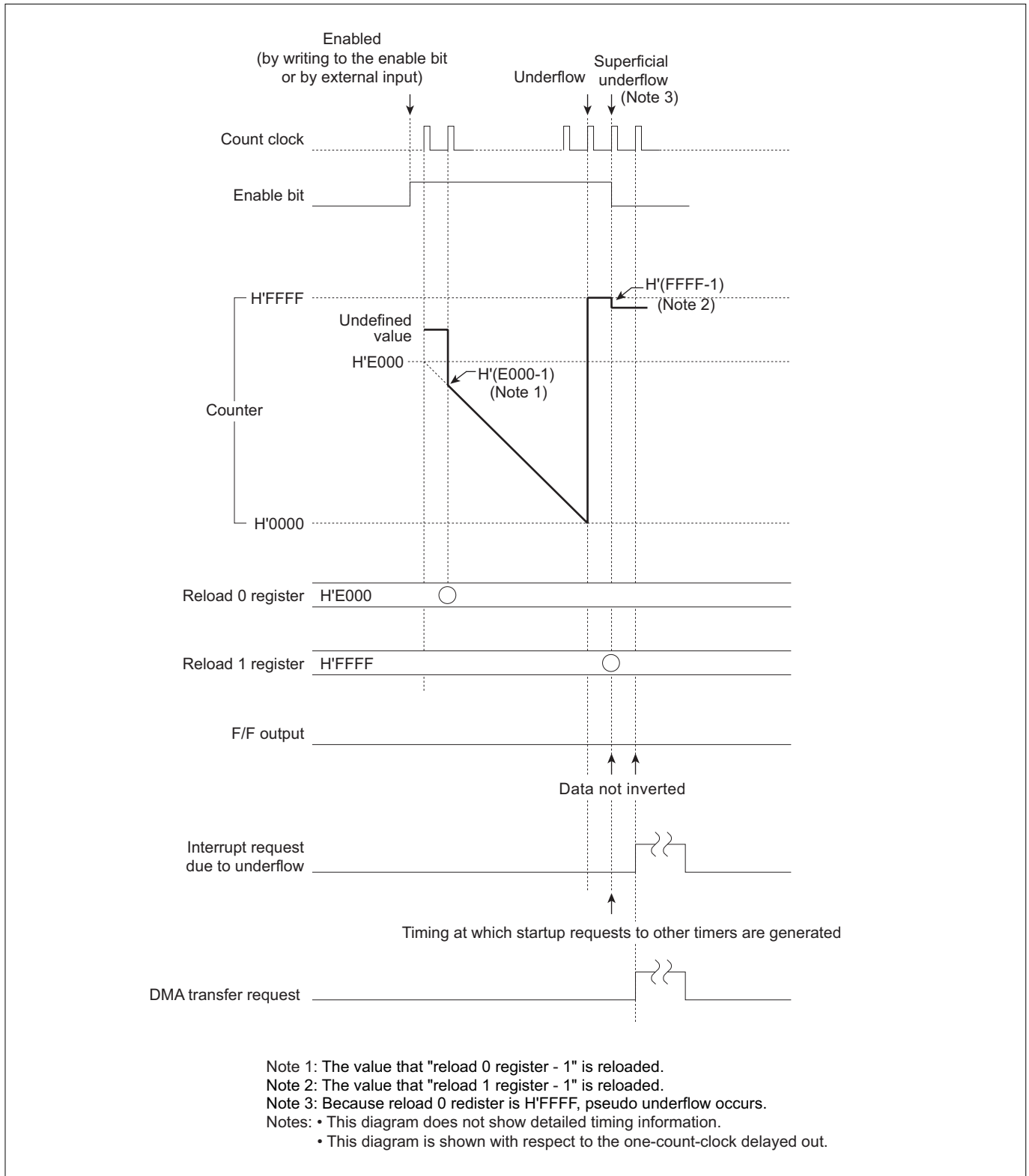
Appendix Figure 4.9.6 Typical Operation in PWM Output Mode (Reload 0 Register:  $H'FFFF$ )



Appendix Figure 4.9.7 Typical Operation in PWM Output Mode (Reload 1 Register: H'FFFF)



Appendix Figure 4.9.8 Typical Operation in Single-shot PWM Output Mode (Reload 0 Register: H'FFFF)



**Appendix Figure 4.9.9 Typical Operation in Single-shot PWM Output Mode (Reload 1 Register: H'FFFF)**

### Appendix 4.10 Notes on the A/D Converter

- **Forcible termination during scan operation**

If A/D conversion is forcibly terminated by setting the A/D conversion stop bit (ADCSTP) to "1" during scan mode operation and the A/D data register for the channel that was in the middle of conversion is accessed for read, the read value shows the last conversion result that had been transferred to the data register before the conversion was forcibly terminated.

- **Modification of the A/D converter related registers**

If the content of any register—A/D Conversion Interrupt Control Register, Single or Scan Mode Registers or A/D Successive Approximation Register, except the A/D conversion stop bit—is modified in the middle of A/D conversion, the conversion result cannot be guaranteed. Therefore, do not modify the contents of these registers while A/D conversion is in progress, or be sure to restart A/D conversion if register contents have been modified.

- **Handling of analog input signals**

When using the A/D Converter with its sample-and-hold function disabled, make sure the analog input level is fixed during A/D conversion.

- **A/D conversion completed bit read timing**

To read the A/D conversion completed bit (the Single Mode Register 0 ADSCMP bit or the Scan Mode Register 0 ADCCMP bit), as well as the A/D simultaneous sampling status bit (the A/D0 Single Mode Register 2 ADSSH2ST bit) immediately after A/D conversion has started or has been terminated by the A/D conversion stop bit, be sure to adjust the timing 6 BCLK periods by performing a dummy read of their registers before read.

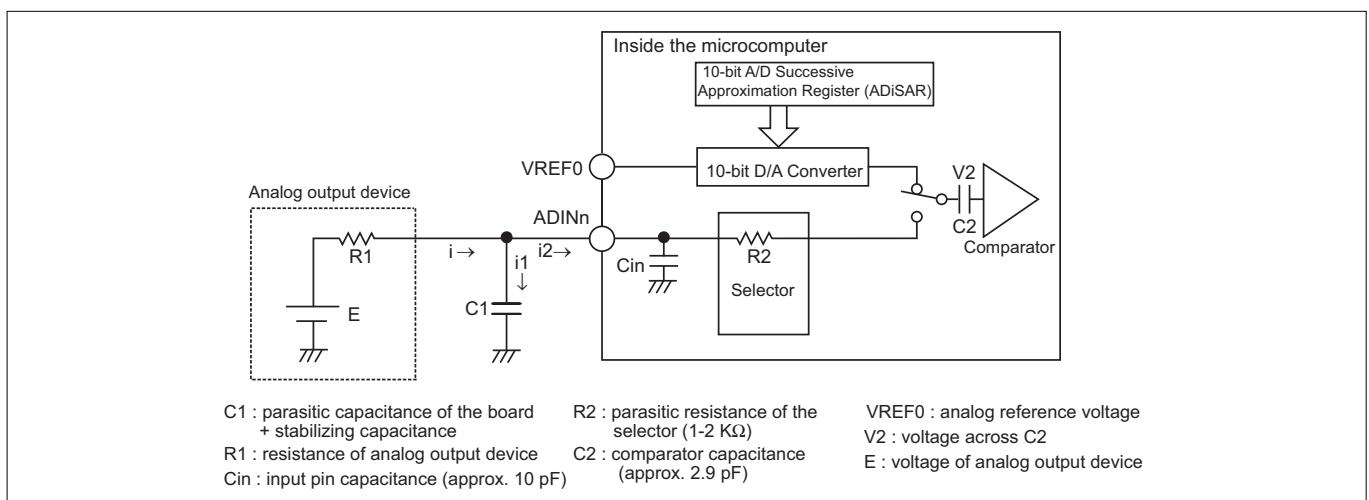
- **Regarding the analog input pins**

Appendix Figure 4.10.1 shows the internal equivalent circuit of the A/D Converter's analog input part. To obtain accurate A/D conversion results, make sure the internal capacitor C2 of the A/D conversion circuit is charged up within a predetermined time (sampling time). To meet this sampling time requirement, it is recommended that a stabilizing capacitor C1 be connected external to the chip.

The method for determining the necessary value of this external stabilizing capacitor with respect to the output impedance of an analog output device is described below. Also, an explanation is made of the case where the output impedance of an analog output device is low and the external stabilizing capacitor C1 is unnecessary.

- **Rated value of the absolute accuracy**

The rated value of the absolute accuracy is the actual performance value of the microcomputer alone, with influences of the power supply wiring and noise on the board not taken into account. When designing the application system, use caution for the board layout by, for example, separating the analog circuit power supply and ground (AVCC, AVSS and VREF) from those of the digital circuit and incorporating measures to prevent the analog input pins from being affected by noise, etc. from other digital signals.



**Appendix Figure 4.10.1 Internal Equivalent Circuit of the Analog Input Part**



### (a) Example for calculating the external stabilizing capacitor C1 (addition of this capacitor is recommended)

Assuming the R1 in Appendix Figure 4.10.1 is infinitely large and that the current necessary to charge the internal capacitor C2 is supplied from C1, if the potential fluctuation, Vp, caused by capacitance division of C1 and C2 is to be within 0.1 LSB, then what amount of capacitance C1 should have. For a 10-bit A/D Converter where VREF0 is 5.12 V, 1 LSB determination voltage = 5.12 V / 1,024 = 5 mV. The potential fluctuation of 0.1 LSB means a 0.5 mV fluctuation.

The relationship between the capacitance division of C1 and C2 and the potential fluctuation, Vp, is obtained by the equation below:

$$V_p = \frac{C_2}{C_1 + C_2} \times (E - V_2) \quad \text{----- Eq. A-1}$$

Vp is also obtained by the equation below:

$$V_p = V_{p1} \times \sum_{i=0}^{x-1} \frac{1}{2^i} < \frac{V_{REF0}}{10 \times 2^x} \quad \text{----- Eq. A-2}$$

where Vp1 = potential fluctuation in the first A/D conversion performed and x = 10 for a 10-bit resolution A/D converter

When Eq. A-1 and Eq. A-2 are solved, the following results:

$$C_1 = C_2 \left\{ \frac{E - V_2}{V_{p1}} - 1 \right\} \quad \text{----- Eq. A-3}$$

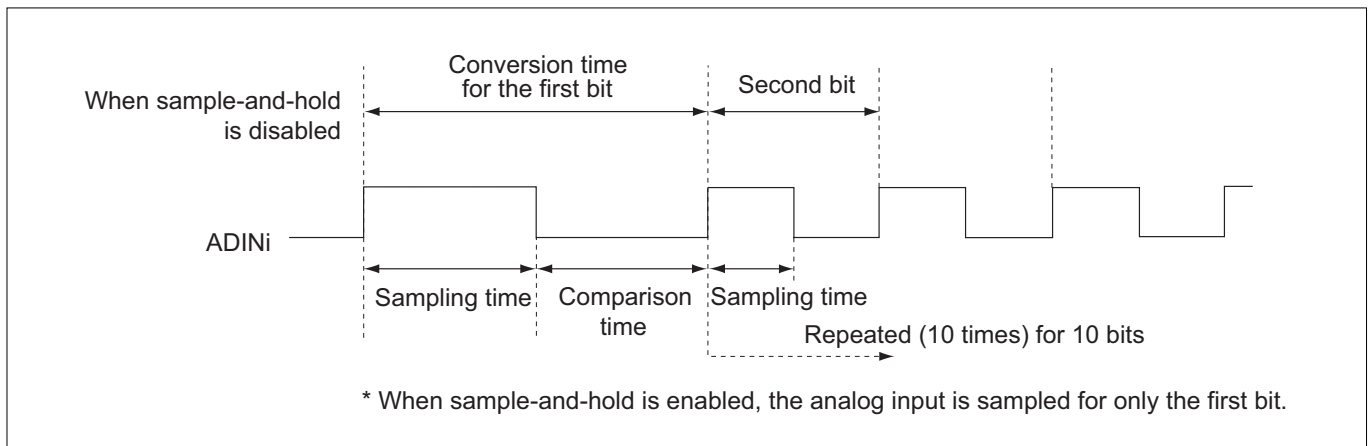
$$\therefore C_1 > C_2 \left\{ 10 \times 2^x \times \sum_{i=0}^{x-1} \frac{1}{2^i} - 1 \right\} \quad \text{----- Eq. A-4}$$

Thus, for a 10-bit resolution A/D Converter where C2 = 2.9 pF, C1 is 0.06 μF or more. Use this value for reference when setting up C1.

### (b) Maximum value of the output impedance R1 when C1 is not added

If the external capacitor C1 in Appendix Figure 4.10.1 is not used, examination must be made to see if the analog output device can fully charge C2 within a predetermined time. First, the equation to find i2 when C1 in Appendix Figure 4.10.1 does not exist is shown below.

$$i_2 = \frac{C_2(E - V_2)}{C_{in} \times R_1 + C_2(R_1 + R_2)} \times \exp \left\{ \frac{-t}{C_{in} \times R_1 + C_2(R_1 + R_2)} \right\} \quad \text{----- Eq. B-1}$$



**Appendix Figure 4.10.2 A/D Conversion Timing Diagram**

Appendix Figure 4.10.2 shows an A/D conversion timing diagram. C2 must be charged up within the sampling time shown in this diagram. When the sample-and-hold function is disabled, the sampling time for the second and subsequent bits is about half that of the first bit.

The sampling times at the respective conversion speeds are listed in the Appendix Table 4.10.1. Note that when the sample-and-hold function is enabled, the analog input is sampled for only the first bit.

**Appendix Table 4.10.1 Sampling Time (in Which C2 Needs to Be Charged)**

Conversion start method		Conversion speed		Sampling time for the first bit	Sampling time for the 2nd and subsequent bits
2BCLK mode	Single mode (when sample-and-hold disabled or normal)	Slow mode	Normal speed	55BCLK	27BCLK
			Double speed	31BCLK	15BCLK
	sample-and-hod enabled	Fast mode	Normal speed	23BCLK	11BCLK
			Double speed	15BCLK	7BCLK
	Single mode (when fast sample- and-hold enabled)	Slow mode	Normal speed	55BCLK	–
			Double speed	31BCLK	–
		Fast mode	Normal speed	23BCLK	–
			Double speed	15BCLK	–
	Comparator mode	Slow mode	Normal speed	55BCLK	–
			Double speed	31BCLK	–
		Fast mode	Normal speed	23BCLK	–
			Double speed	15BCLK	–
Simultaneous sampling	Slow mode	Normal speed	55BCLK	–	
		Double speed	31BCLK	–	
	Fast mode	Normal speed	23BCLK	–	
		Double speed	15BCLK	–	

Therefore, the time in which C2 needs to be charged is found from Eq. B-1, as follows:

$$\text{Sampling time (in which C2 needs to be charged)} > C_{in} \times R1 + C2(R1 + R2) \text{ ---- Eq. B-2}$$

Thus, the maximum value of R1 can be obtained as a criterion from the equation below. Note, however, that for single mode (when sample-and-hold is disabled), the sampling time for the second and subsequent bits (C2 charging time) must be applied.

$$R1 < \frac{C2 \text{ charging time} - C2 \times R2}{C_{in} + C2}$$

## Appendix 4.11 Notes on Serial Interface

### Appendix 4.11.1 Notes on Using CSIO Mode

- **Settings of SIO Transmit/Receive Mode Register and SIO Baud Rate Register**

The SIO Transmit/Receive Mode Register, SIO Special Mode Register and SIO Baud Rate Register and the Transmit Control Register's BRG count source select bit must always be set when the serial interface is not operating. If a transmit or receive operation is in progress, wait until the transmit and receive operations are finished and then clear the transmit and receive enable bits before making changes.

- **Settings of SIO Baud Rate Register**

Use caution when setting SIO Baud Rate Register so that the transfer rate will not exceed  $f(\text{BCLK})/8$ .

- **About successive transmission**

To transmit data successively, make sure the next transmit data is set in the SIO Transmit Buffer Register before the current data transmission finishes.

- **About reception**

Because the receive shift clock in CSIO mode is derived by an operation of the transmit circuit, transmit operation must always be executed (by sending dummy data) even when the serial interface is used for only receiving data. In this case, be aware that if the port function is set for the TXD pin (by setting the operation mode register to "1"), dummy data may actually be output from the pin.

- **About successive reception**

To receive data successively, make sure that data (dummy data) is set in the SIO Transmit Buffer Register before a transmit operation on the transmitter side starts.

- **Transmission/reception using DMA**

To transmit/receive data in DMA request mode, enable the DMAC to accept transfer requests (by setting the DMA Mode Register) before serial communication starts.

- **About reception finished bit**

If a receive error (overrun error) occurs, the reception finished bit can only be cleared by clearing the receive enable bit, and cannot be cleared by reading out the receive buffer register.

- **About overrun error**

If all bits of the next received data have been set in the SIO Receive Shift Register before reading out the SIO Receive Buffer Register (i.e., an overrun error occurred), the received data is not stored in the receive buffer register, with the previous received data retained in it. Although a receive operation continues thereafter, the subsequent received data is not stored in the receive buffer register (receive status bit = "1").

Before normal receive operation can be restarted, the receive enable bit must be temporarily cleared to "0." And this is the only way that the overrun error flag can be cleared.

- **About DMA transfer request generation during SIO transmission**

If the transmit buffer register becomes empty (transmit buffer empty flag = "1") while the transmit enable bit remains set to "1" (transmission enabled), an SIO transmit buffer empty DMA transfer request is generated.

- **About DMA transfer request generation during SIO reception**

If the reception finished bit is set to "1" (receive buffer register full), a reception finished DMA transfer request is generated. Be aware, however, that if an overrun error occurred during reception, this DMA transfer request is not generated.

- **Switching from general-purpose to serial interface pin**

When switching general-purpose to serial interface pin, SCLKOn pin outputs "H" level (For the case of selecting internal clock and setting CKPOL bit to "0." When setting CKPOL bit to "1," it outputs "L" level.), and TXDn pin outputs undefined value. However, when switching general-purpose to serial interface pin with setting TEN bit of the SIOOn transmit control register to "1" (transmit enable), TXDn pin outputs the last bit level of the previously output serial data.

### Appendix 4.11.2 Notes on Using UART Mode

- **Settings of SIO Transmit/Receive Mode Register and SIO Baud Rate Register**

The SIO Transmit/Receive Mode Register, SIO Special Mode Register and SIO Baud Rate Register and the Transmit Control Register's BRG count source select bit must always be set when the serial interface is not operating. If a transmit or receive operation is in progress, wait until the transmit and receive operations are finished and then clear the transmit and receive enable bits before making changes.

- **Settings of SIOOn Baud Rate Register (SIOOnBAUR)**

Writes to the SIO Baud Rate Register take effect in the next cycle after the BRG counter has finished counting. However, if the register is accessed for write while transmission and reception are disabled, the written value takes effect at the same time it is written.

- **Transmission/reception using DMA**

To transmit/receive data in DMA request mode, enable the DMAC to accept transfer requests (by setting the DMA Mode Register) before serial communication starts.

- **About overrun error**

If all bits of the next received data have been set in the SIO Receive Shift Register before reading out the SIO Receive Buffer Register (i.e., an overrun error occurred), the received data is not stored in the receive buffer register, with the previous received data retained in it. Once an overrun error occurs, although a receive operation continues, the subsequent received data is not stored in the receive buffer register. Before normal receive operation can be restarted, the receive enable bit must be temporarily cleared. And this is the only way that the overrun error flag can be cleared.

- **Flags showing the status of UART receive operation**

There are following flags that indicate the status of receive operation during UART mode:

- SIO Receive Control Register receive status bit
- SIO Receive Control Register reception finished bit
- SIO Receive Control Register receive error sum bit
- SIO Receive Control Register overrun error bit
- SIO Receive Control Register parity error bit
- SIO Receive Control Register framing error bit

The manner in which the reception finished bit and various error flags are cleared differs depending on whether an overrun error occurred, as described below.

[When an overrun error did not occur]

Cleared by reading out the lower byte of the receive buffer register or by clearing the receive enable bit.

[When an overrun error occurred]

Cleared by only clearing the receive enable bit.

- **Switching from general-purpose to serial interface pin**

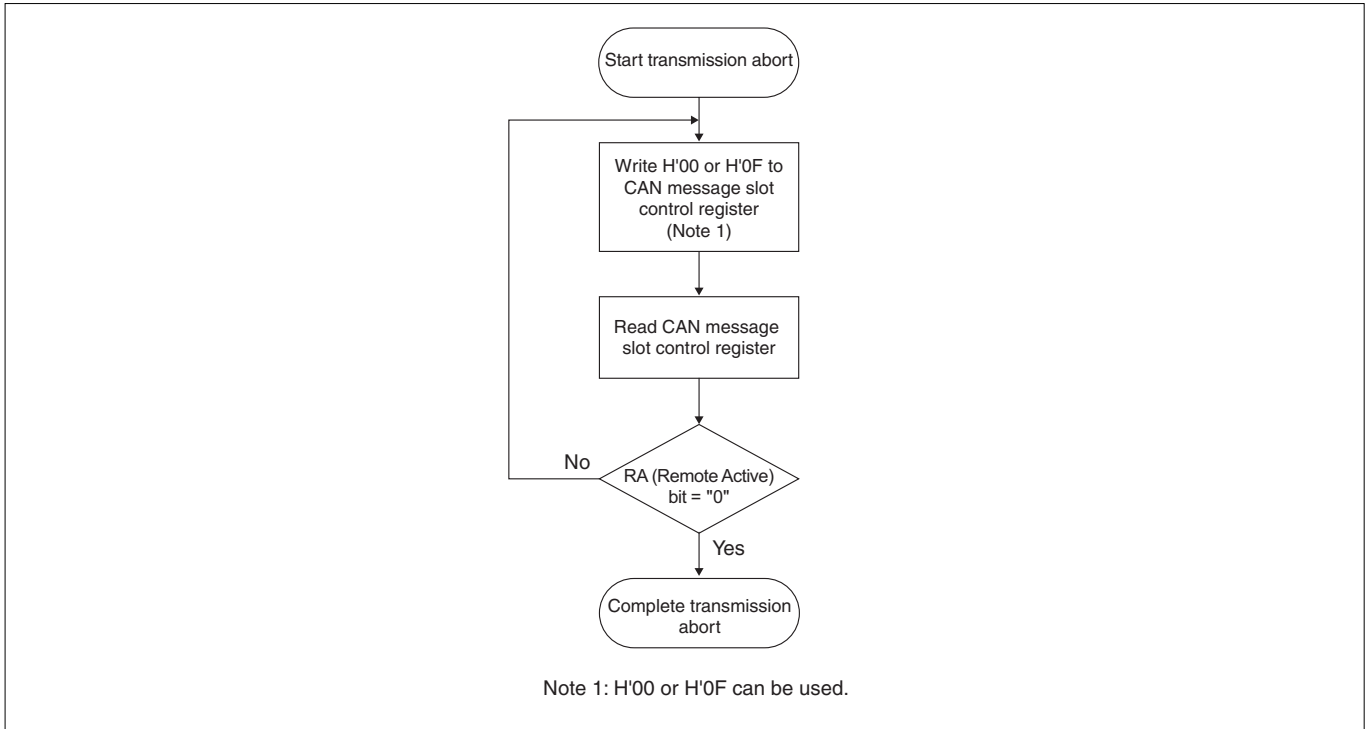
When switching from general-purpose port to the serial interface pin by the port operation mode register, the terminal TXDn pin outputs "H" level.

### Appendix 4.12 Notes on CAN Module

- **Note for cancelation of transmit and receive CAN remote frame**

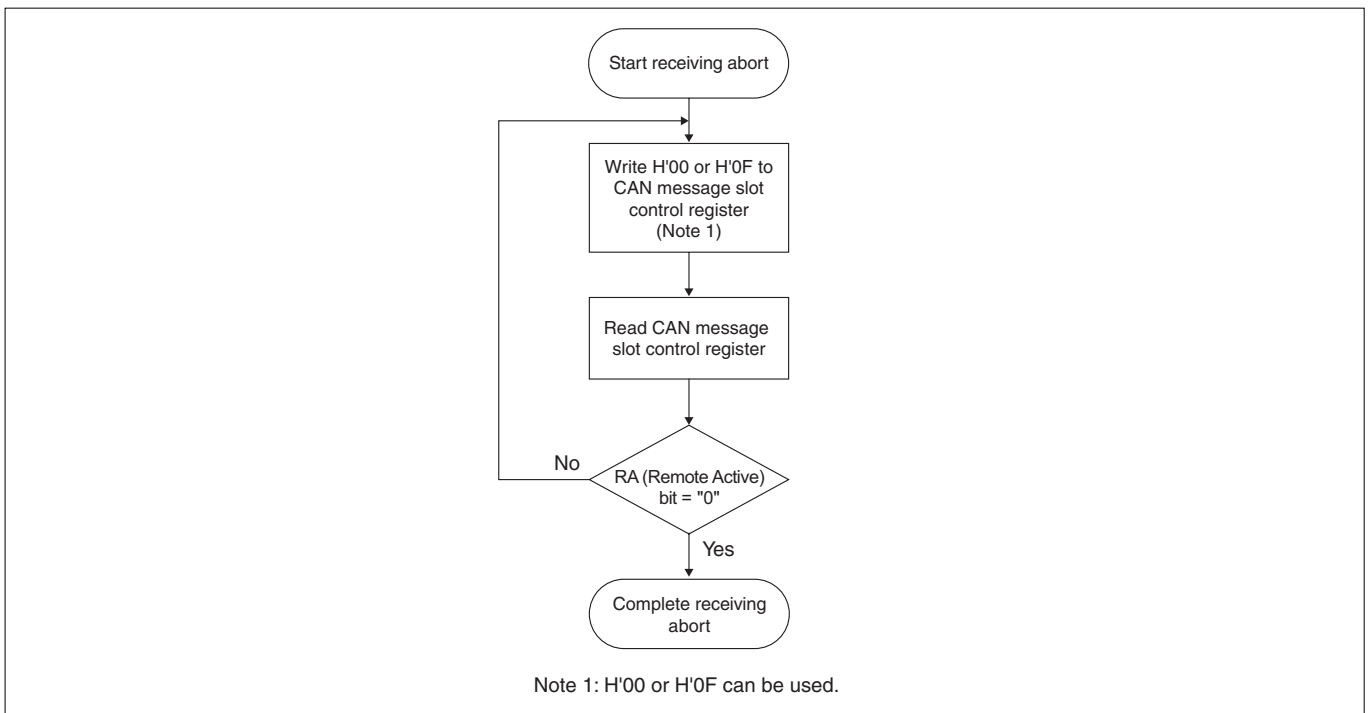
When aborting remote frame transmission or canceling remote frame receiving, make sure that the RA (Remote Active) bit is cleared to "0" after writing "H'00" or "H'0F" to the CAN Message Slot Control Register.

#### (1) When aborting remote frame transmission



Appendix Figure 4.12.1 Operation Flow when Aborting Remote Frame Transmission

#### (2) When canceling remote frame receiving



Appendix Figure 4.12.2 Operation Flow when Canceling Remote Frame Receiving

#### Appendix 4.13 Notes on DRI

Precautions about the DRI is shown below.

- In order that the data writing from DRI and RTD to internal RAM use the exclusive bus prepared apart from M32 R-FPU, do not usually generate the competition with access from other bus masters (CPU, DMA, NBD, SDI). However DRI transfer, RTD transfer and the access (read-out/writing) from other bus master occur at the same time for areas of the 16-K byte unit of internal RAM, access competition occurs. When access competition occurs, mediation is operated according to the following priority.

NBD/SDI > DMA > CPU > DRI > RTD

#### Appendix 4.14 Notes on RAM Backup Mode

##### Appendix 4.14.1 Precautions to Be Observed at Power-On

When changing portn from input mode to output mode after power-on, pay attention to the following.

If port n is set for output mode while no data is set in the Portn Data Register, the port's initial output level is instable. Therefore, before changing portn for output mode, make sure the Portn Data Register is set to output a "H."

Unless this precaution is followed, port output may go "L" at the same time the port is set for output after the oscillation has stabilized, causing the microcomputer to enter RAM backup mode.

##### Appendix 4.14.2 Power-On Limitation

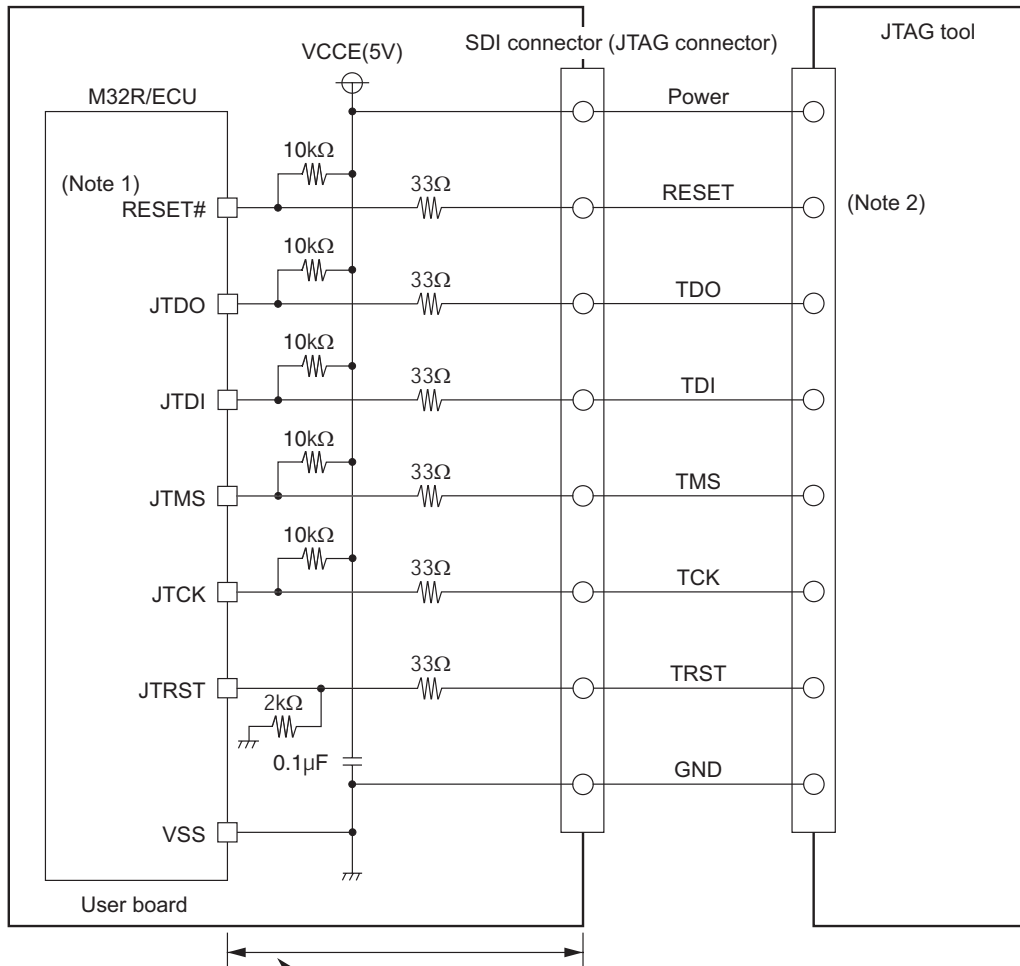
When powering on, make sure to meet the limitation  $VDDE \geq VCCER$ . If  $VDDE$  is 3.0 V or more, there will be no problem even when the limitation  $VDDE \geq VCCER$  cannot be met.

When the above power-on limitation cannot be met, sufficient evaluation must be made during system design in order to ensure that no power will be applied to the microcomputer with a potential difference of 1 V or more. For potential differences 0 V to 0.6 V, there is almost no in-flow current. The amount of in-flow current begins to increase when the potential difference exceeds 0.6 V.

#### Appendix 4.15 Notes on JTAG

##### Appendix 4.15.1 Notes on Board Design when Connecting JTAG

To materialize fast and highly reliable communication with JTAG tools, make sure wiring lengths of JTAG pins are matched during board design.



Make sure wiring lengths are the same, and avoid bending wires as much as possible. Be careful not to use through-holes within the wiring.

Note 1: The RESET# related circuit and resistance-capacitance values must be determined depending on the user board's system design conditions and the microcomputer's operating conditions.

Note 2: N-channel open-drain output is recommended for the RESET output of JTAG tools. For details, see JTAG tool specifications.

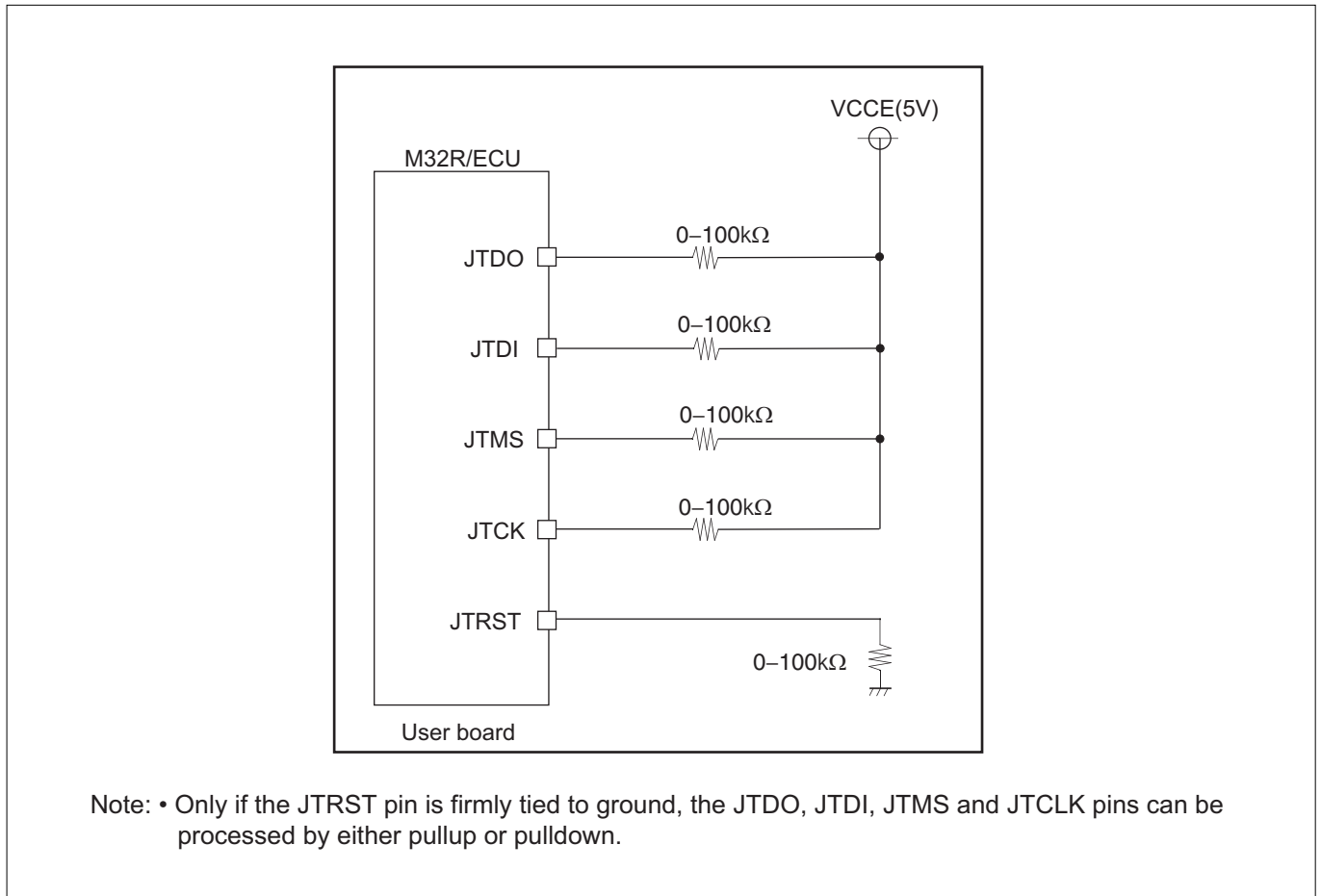
Notes: • Only if the JTRST pin is firmly tied to ground, the JTDO, JTDI, JTMS and JTCLK pins can be processed by either pullup or pulldown.  
• Each of these pins must always be processed even when not using JTAG tools.  
The same pullup/pulldown resistance values as when using JTAG tools may be used.

Appendix Figure 4.15.1 Notes on Board Design when Connecting JTAG Tools



#### Appendix 4.15.2 Processing Pins when Not Using JTAG

The following shows how the pins on the chip should be processed when not using JTAG tools.



Appendix Figure 4.15.2 Processing Pins when Not Using JTAG

#### Appendix 4.16 Notes on Noise

The following describes precautions to be taken about noise and corrective measures against noise. The corrective measures described here are theoretically effective for noise, but require that the application system incorporating those measures be fully evaluated before it can actually be put to use.

##### Appendix 4.16.1 Reduction of Wiring Length

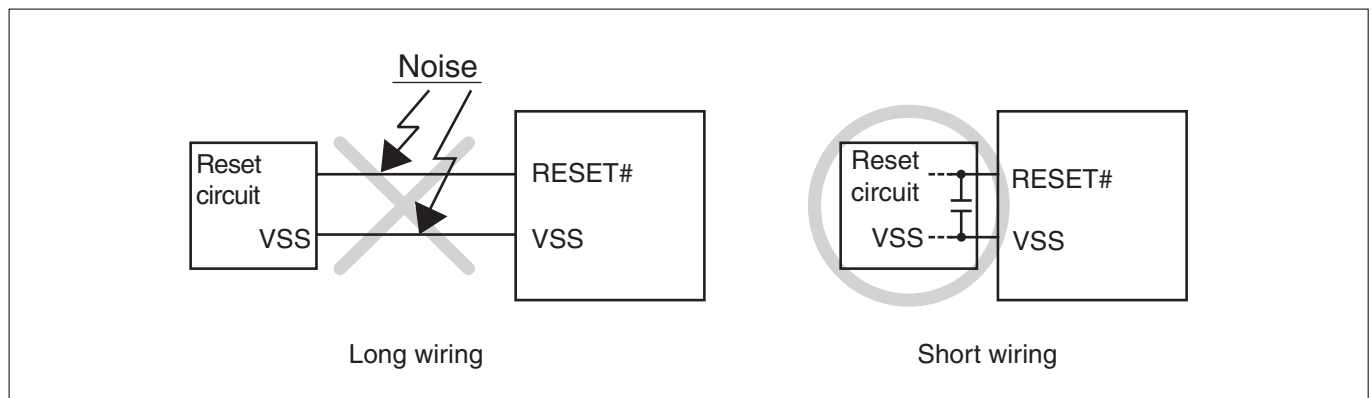
Wiring on the board may serve as an antenna to draw noise into the microcomputer. Shorter the total wiring length, the smaller the possibility of drawing noise into the microcomputer.

###### (1) Wiring of the RESET# pin

Reduce the length of wiring connecting to the RESET# pin. Especially when connecting a capacitor between the RESET# and VSS pins, make sure it is wired to each pin in the shortest distance possible (within 20 mm).

###### <Reasons>

Reset is a function to initialize the internal logic of the microcomputer. The width of a pulse applied to the RESET# pin is important and is therefore specified as part of timing requirements. If a pulse in width shorter than the specified duration (i.e., noise) is applied to the RESET# pin, the microcomputer will not be reset for a sufficient duration of time and come out of reset before its internal logic is fully initialized, causing the program to malfunction.



Appendix Figure 4.16.1 Example Wiring of the RESET# Pin

#### (2) Wiring of clock input/output pins

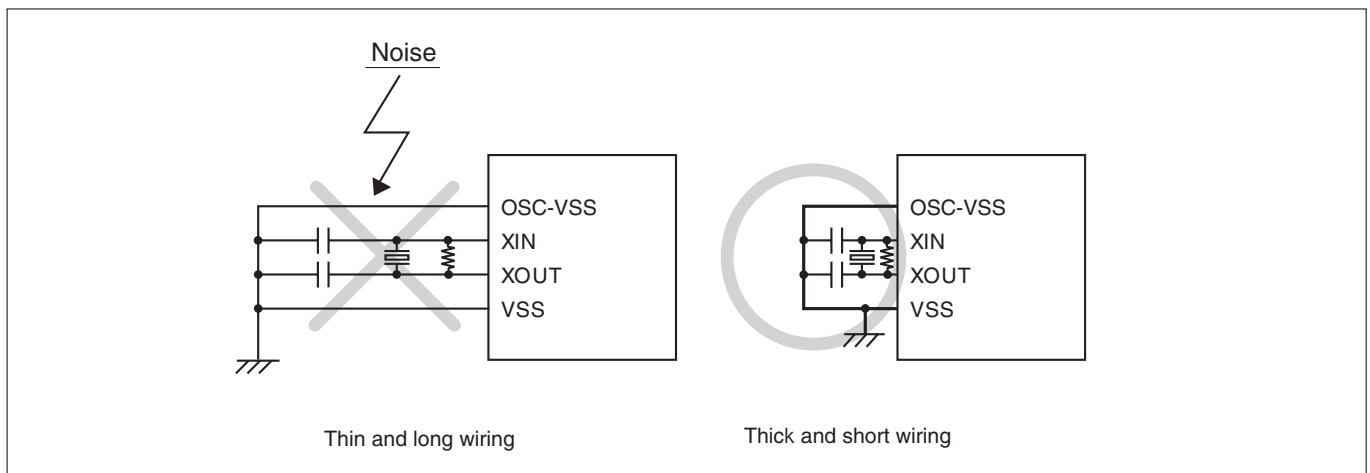
Use as much thick and short wiring as possible for connections to the clock input/output pins.

When connecting a capacitor to the oscillator, make sure its grounding lead wire and the OSC-VSS pin on the microcomputer are connected in the shortest distance possible (within 20 mm).

Also, make sure the VSS pattern used for clock oscillation is a large ground plane and is connected to GND.

##### <Reasons>

The microcomputer operates synchronously with the clock generated by an oscillator circuit. Inclusion of noise on the clock input/output pins causes the clock waveform to become distorted, which may result in the microcomputer operating erratically or getting out of control. Furthermore, if a noise-induced potential difference exists between the microcomputer's VSS level and that of the oscillator, the clock fed into the microcomputer may not be an exact clock.



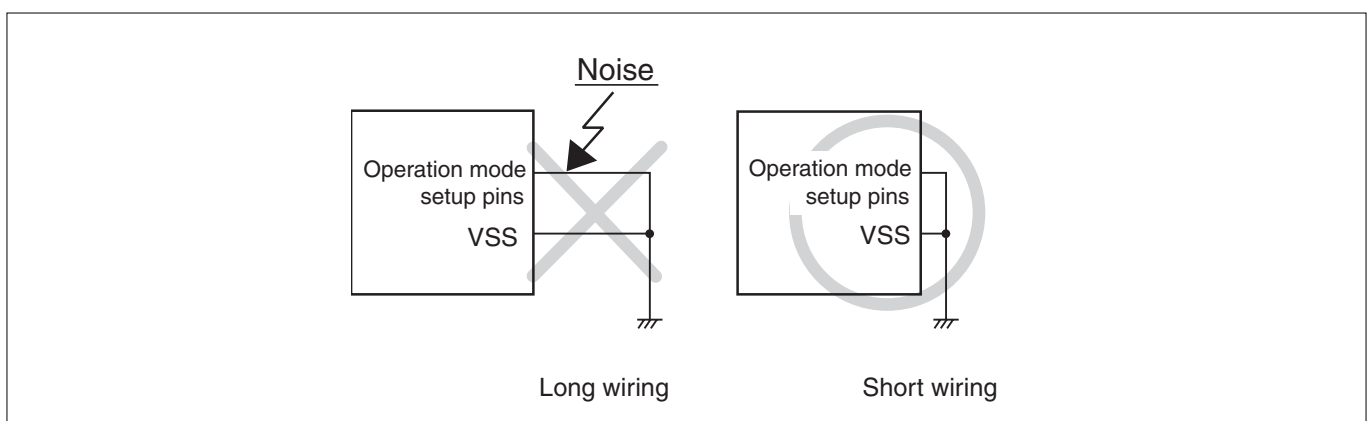
Appendix Figure 4.16.2 Example Wiring of Clock Input/Output Pins

#### (3) Wiring of the operation mode setup pins

When connecting the operation mode setup pins and the VCC or VSS pin, make sure they are wired in the shortest distance possible.

##### <Reasons>

The levels of the operation mode setup pins affect the microcomputer's operation mode. When connecting the operation mode setup pins and the VCC or VSS pin, be careful that no noise-induced potential difference will exist between the operation mode setup pins and the VCC or VSS pin. This is because the presence of such a potential difference makes operation mode unstable, which may result in the microcomputer operating erratically or getting out of control.

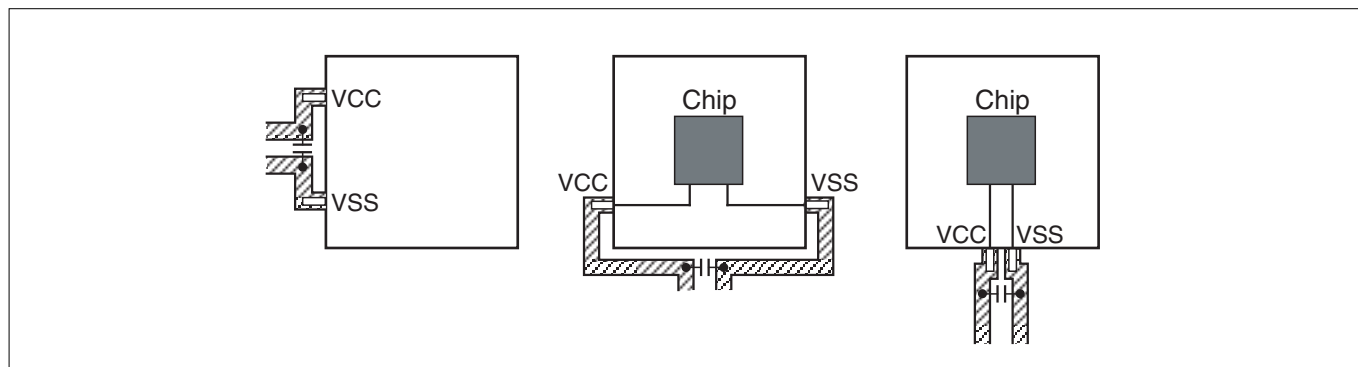


Appendix Figure 4.16.3 Example Wiring of the MOD0 and MOD1 Pins

#### Appendix 4.16.2 Inserting a Bypass Capacitor between VSS and VCC Lines

Insert a bypass capacitor of about 0.1  $\mu\text{F}$  between the VSS and VCC lines. At this time, make sure the requirements described below are met.

- The wiring length between the VSS pin and bypass capacitor and that between the VCC pin and bypass capacitor are the same.
- The wiring length between the VSS pin and bypass capacitor and that between the VCC pin and bypass capacitor are the shortest distance possible.
- The VSS and VCC lines have a greater wiring width than that of all other signal lines.



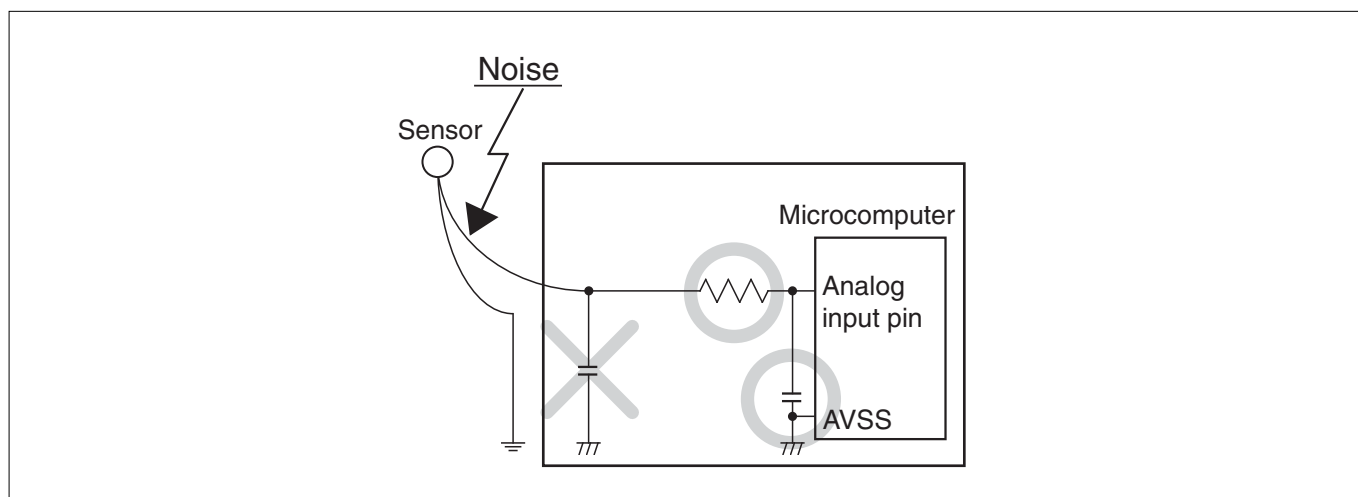
Appendix Figure 4.16.4 Example of a Bypass Capacitor Inserted between VSS and VCC Lines

#### Appendix 4.16.3 Processing Analog Input Pin Wiring

Insert a resistor of about 100 to 500 $\Omega$  in series to the analog signal line connecting to the analog input pin at a position as close to the microcomputer as possible. Also, insert a capacitor of about 100 pF between the analog input pin and AVSS pin at a position as close to the AVSS pin as possible.

##### <Reasons>

The signal fed into the analog input pin (e.g., A/D converter input pin) normally is an output signal from a sensor. In many cases, a sensor to detect changes of event is located apart from the board on which the microcomputer is mounted, so that wiring to the analog input pin is inevitably long. Because a long wiring serves as an antenna which draws noise into the microcomputer, the signal fed into the analog input pin tends to be noise-ridden. Furthermore, if the capacitor connected between the analog input pin and AVSS pin is grounded at a position apart from the AVSS pin, noise riding on the ground line may penetrate into the microcomputer via the capacitor.



Appendix Figure 4.16.5 Example of a Resistor and Capacitor Inserted for the Analog Signal Line

#### Appendix 4.16.4 Consideration about the Oscillator

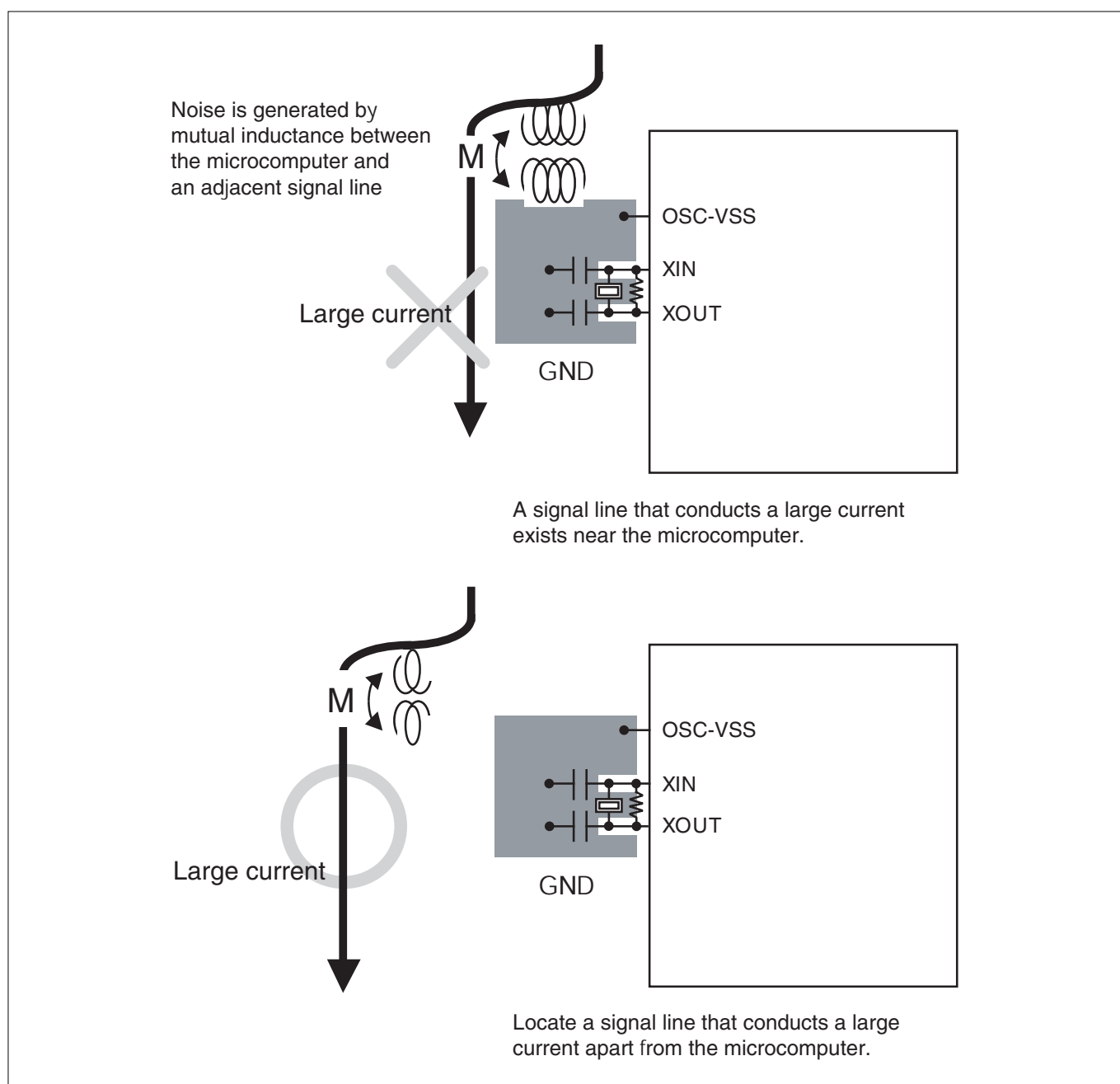
The oscillator that generates the fundamental clock for microcomputer operation requires consideration to make it unsusceptible to influences from other signals.

##### (1) Avoidance from large-current signal lines

Signal lines that conduct a large current exceeding the range of current values that the microcomputer can handle must be routed as far away from the microcomputer (especially the oscillator) as possible. Also, make sure the circuit is protected with a GND pattern.

##### <Reasons>

Systems using a microcomputer have signal lines to control a motor, LED or thermal head, for example. When a large current flows in these signal lines, it generates noise due to mutual inductance (M).



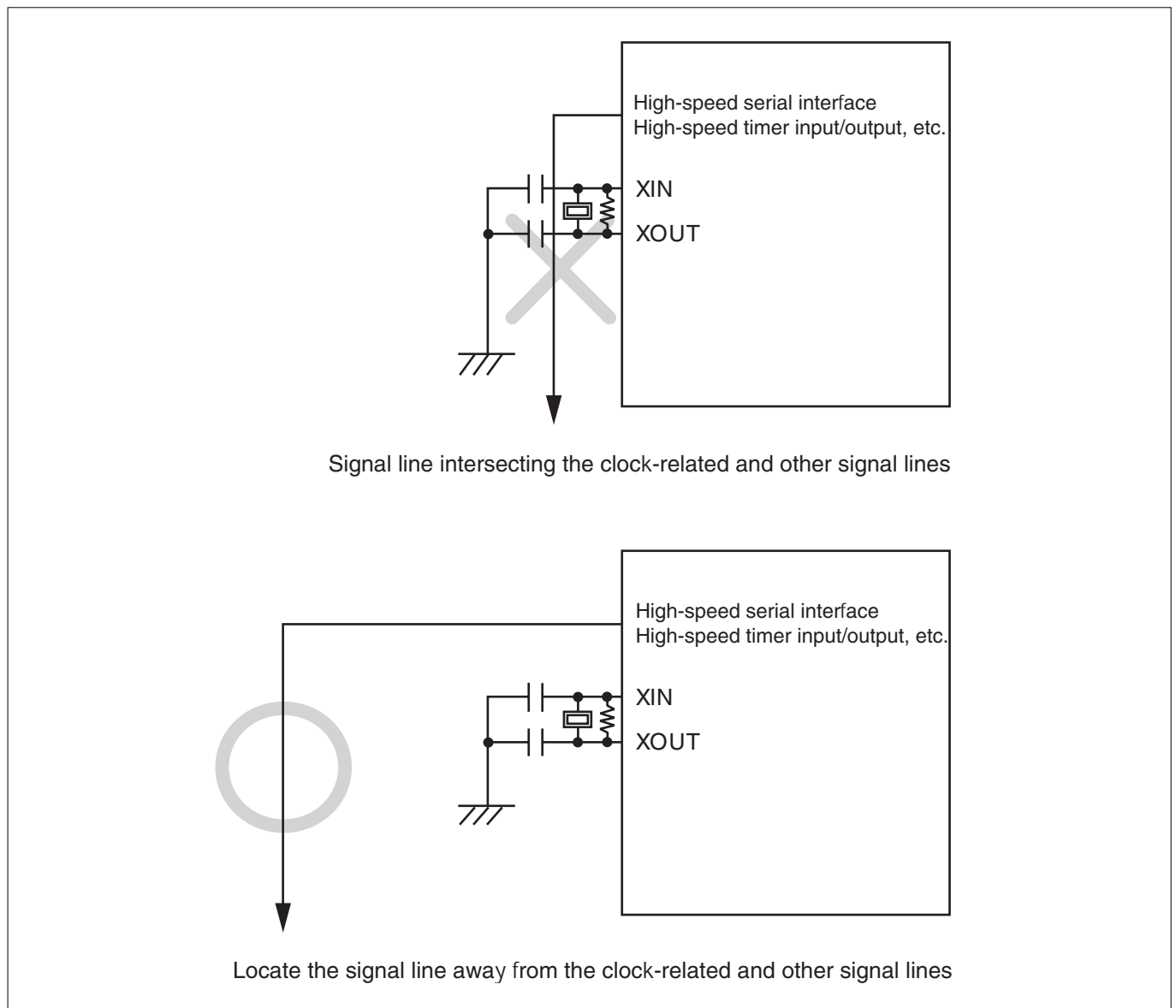
Appendix Figure 4.16.6 Example Wiring of a Large-Current Signal Line

#### (2) Avoiding effects of rapidly level-changing signal lines

Locate signal lines whose levels change rapidly as far away from the oscillator as possible. Also, make sure the rapidly level-changing signal lines will not intersect the clock-related signal lines and other noise-sensitive signal lines.

##### <Reasons>

Rapidly level-changing signal lines tend to affect other signal lines as their voltage level frequently rises and falls. Especially if these signal lines intersect the clock-related signal lines, they will cause the clock waveform to become distorted, which may result in the microcomputer operating erratically or getting out of control.



Appendix Figure 4.16.7 Example Wiring of a Rapidly Level-Changing Signal Line

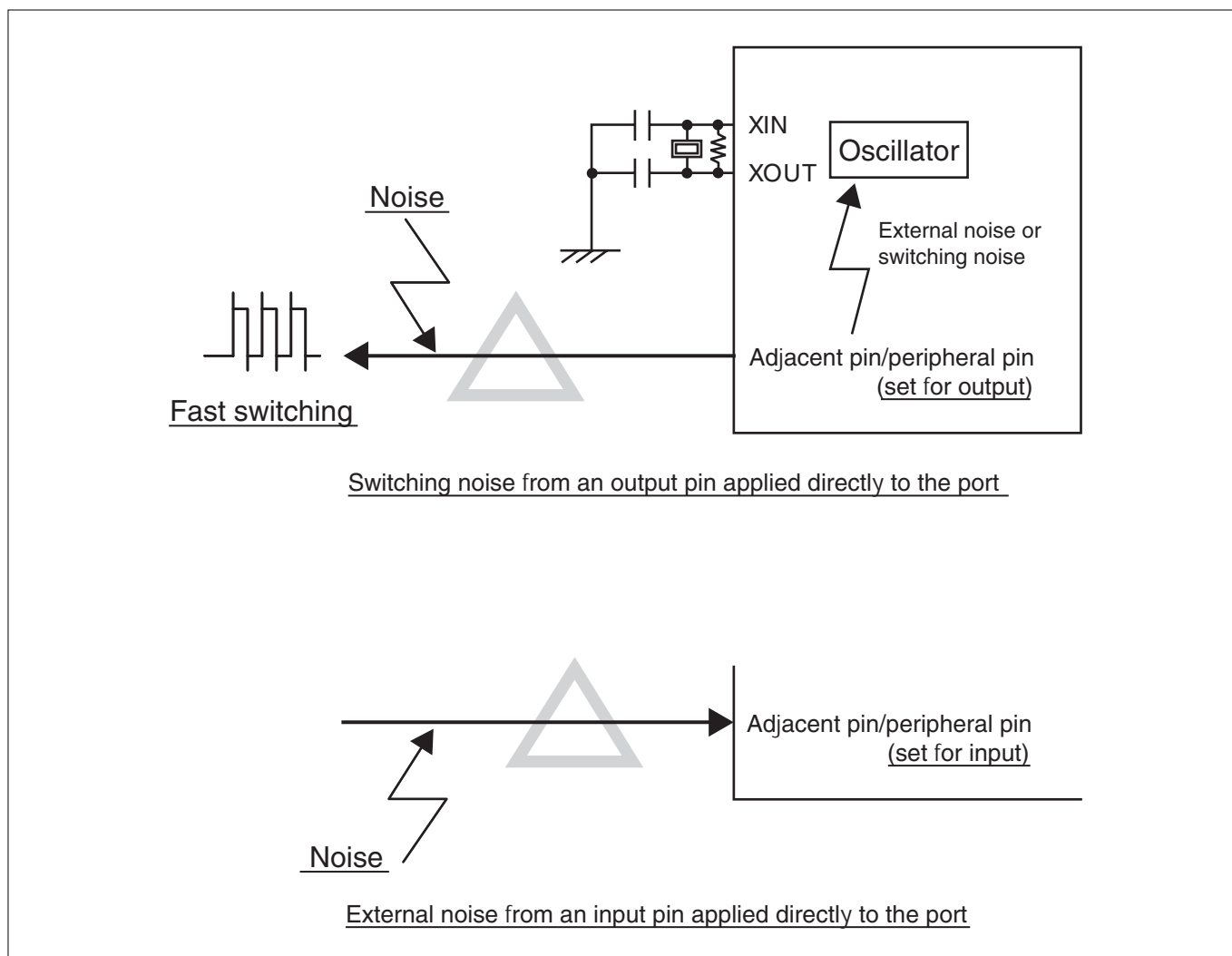
#### (3) Protection against signal lines that are the source of strong noise

Do not use any pin that will probably be subject to strong noise for an adjacent port near the oscillator. If the pin can be left unused, set it for input and connect to GND via a resistor, or fix it to output and leave open. If the pin needs to be used, it is recommended that it be used for input-only.

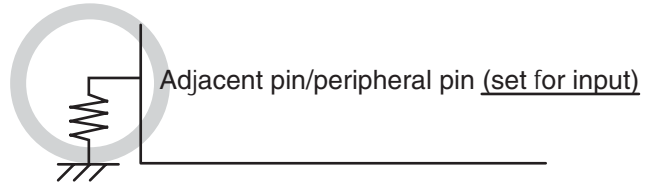
For protection against a still stronger noise source, set the adjacent port for input and connect to GND via a resistor, and use those that belong to the same port group as much for input-only as possible. If greater stability is required, do not use those that belong to the same port group and set them for input and connect to GND via a resistor. If they need to be used, insert a limiting resistor for protection against noise.

#### <Reasons>

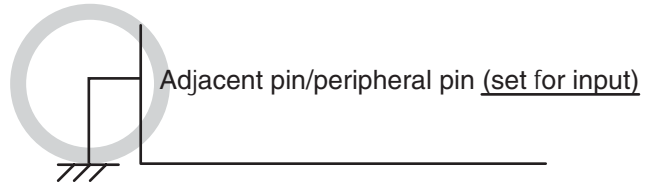
If the ports or pins adjacent to the oscillator operate at high speed or are exposed to strong noise from an external source, noise may affect the oscillator circuit, causing its oscillation to become instable.



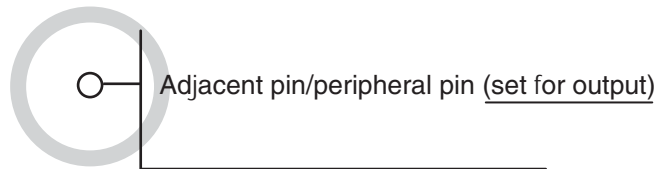
Appendix Figure 4.16.8 Example Processing of a Noise-Laden Pin



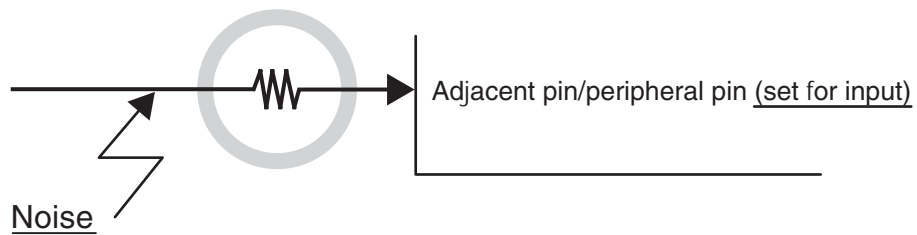
Method for limiting the effect of noise in input mode



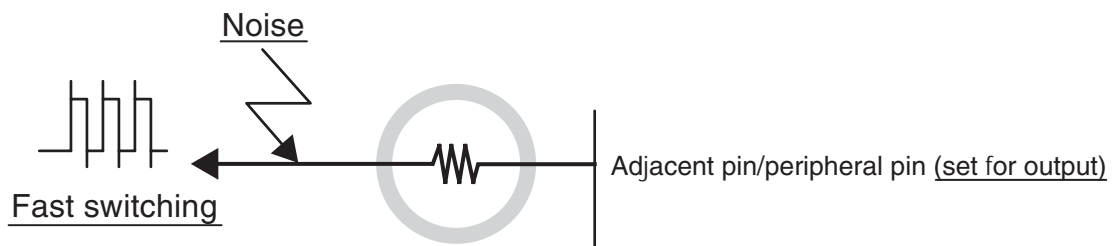
Method for limiting the effect of noise in input mode



Method for limiting the effect of noise in output mode



Method for limiting noise with a resistor



Method for limiting switching noise with a resistor

**Appendix Figure 4.16.9 Example Processing of Pins Adjacent to the Oscillator**



#### Appendix 4.16.5 Processing Input/Output Ports

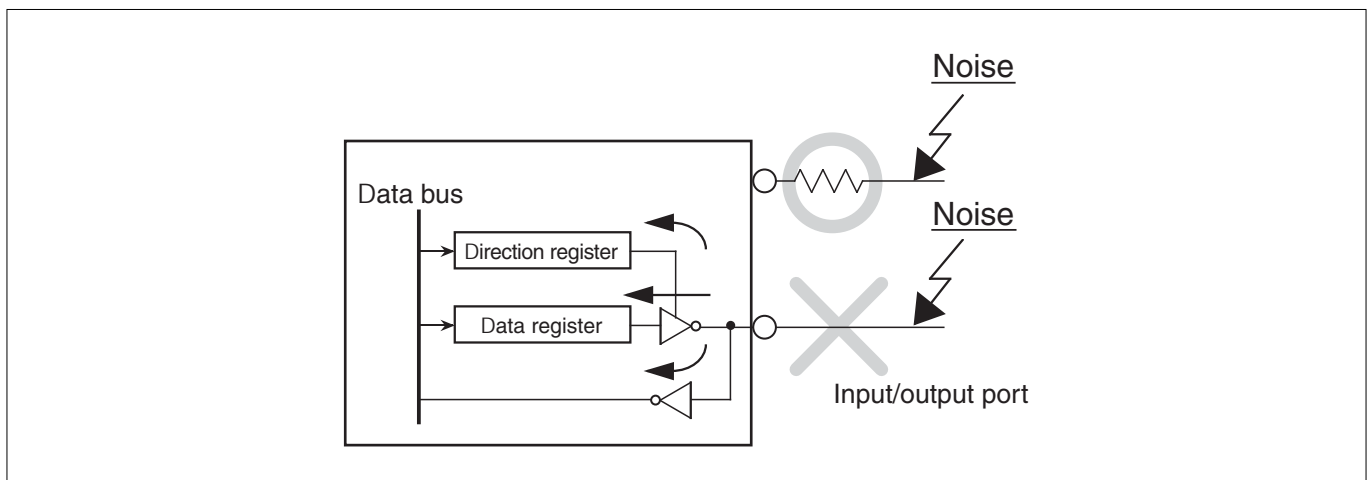
For input/output ports, take the appropriate measures in both hardware and software following the procedure described below.

##### Hardware measures

- Insert resistors of 100Ω or more in series to the input/output ports.

##### Software measures

- For input ports, read out data in a program two or more times to verify that the levels coincide.
- For output ports, rewrite the data register at certain intervals because there is a possibility of the output data being inverted by noise.
- Rewrite the direction register at certain intervals.



Appendix Figure 4.16.10 Example Processing of Input/Output Ports

To be written at a later time.

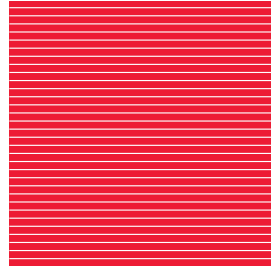
---

**32192/32195/32196 Group Hardware Manual**

**Publication Data : Rev.1.01 Jul 22, 2005  
Rev.1.10 Apr 06, 2007**

**Published by : Sales Strategic Planning Div.  
Renesas Technology Corp.**

# 32192/32195/32196 Group Hardware Manual



Renesas Technology Corp.  
2-6-2, Ote-machi, Chiyoda-ku, Tokyo, 100-0004, Japan